



**THE DATASHEET OF  
MB9BF168RPMC-G-JNE2**





**Please note that Cypress is an Infineon Technologies Company.**

The document following this cover page is marked as “Cypress” document as this is the company that originally developed the product. Please note that Infineon will continue to offer the product to new and existing customers as part of the Infineon product portfolio.

**Continuity of document content**

The fact that Infineon offers the following product as part of the Infineon product portfolio does not lead to any changes to this document. Future revisions will occur when appropriate, and any changes will be set out on the document history page.

**Continuity of ordering part numbers**

Infineon continues to support existing part numbers. Please continue to use the ordering part numbers listed in the datasheet for ordering.



The CY9B160R Series are a highly integrated 32-bit microcontrollers dedicated for embedded controllers with high-performance and competitive cost.

These series are based on the ARM® Cortex®-M4F Processor with on-chip Flash memory and SRAM, and has peripheral functions such as Motor Control Timers, ADCs and Communication Interfaces (UART, CSIO, I<sup>2</sup>C, LIN).

### Features

#### 32-bit ARM® Cortex®-M4F Core

- Processor version: r0p1
- Up to 160 MHz Frequency Operation
- FPU built-in
- Support DSP instruction
- Memory Protection Unit (MPU): improves the reliability of an embedded system
- Integrated Nested Vectored Interrupt Controller (NVIC): 1 NMI (non-maskable interrupt) and 128 peripheral interrupts and 16 priority levels
- 24-bit System timer (Sys Tick): System timer for OS task management

#### On-chip Memories

##### [Flash memory]

These series are based on two independent on-chip Flash memories.

- MainFlash memory
  - Up to 1024 Kbytes
  - Built-in Flash Accelerator System with 16 Kbytes trace buffer memory
  - The read access to Flash memory can be achieved without wait-cycle up to operation frequency of 72 MHz. Even at the operation frequency more than 72 MHz, an equivalent access to Flash memory can be obtained by Flash Accelerator System.
  - Security function for code protection
- WorkFlash memory
  - 32 Kbytes
  - Read cycle:
    - 6 wait-cycle: the operation frequency more than 120 MHz, and up to 160 MHz
    - 4 wait-cycle: the operation frequency more than 72 MHz, and up to 120 MHz
    - 2 wait-cycle: the operation frequency more than 40 MHz, and up to 72 MHz
    - 0 wait-cycle: the operation frequency up to 40 MHz
  - Security function is shared with code protection

##### [SRAM]

This is composed of three independent SRAMs (SRAM0, SRAM1 and SRAM2). SRAM0 is connected to I-code bus or D-code bus of Cortex-M4F core. SRAM1 and SRAM2 are connected to System bus of Cortex-M4F core.

- SRAM0: Up to 64 Kbytes
- SRAM1: Up to 32 Kbytes
- SRAM2: Up to 32 Kbytes

##### External Bus Interface

- Supports SRAM, NOR, NAND Flash and SDRAM device
- Up to 9 chip selects CS0 to CS8 (CS8 is only for SDRAM)
- 8-/16-bit Data width
- Up to 25-bit Address bit
- Maximum Access size: 256M byte
- Supports Address/Data multiplex
- Supports external RDY function
- Supports scramble function
- Possible to set the validity/invalidity of the scramble function for the external areas 0x6000\_0000 to 0xDFFF\_FFFF in 4 Mbytes units.
- Possible to set two kinds of the scramble key
- Note: It is necessary to prepare the dedicated software library to use the scramble function.

##### Multi-function Serial Interface (Max 8 channels)

- 64 bytes with FIFO (the FIFO step numbers are variable depending on the settings of the communication mode or bit length.)
- Operation mode is selectable from the followings for each channel.
  - UART
  - CSIO
  - LIN
  - I<sup>2</sup>C

**[UART]**

- Full-duplex double buffer
- Selection with or without parity supported
- Built-in dedicated baud rate generator
- External clock available as a serial clock
- Hardware Flow control : Automatically control the transmission by CTS/RTS (only ch.4)
- Various error detect functions available (parity errors, framing errors, and overrun errors)

**[CSIO]**

- Full-duplex double buffer
- Built-in dedicated baud rate generator
- Overrun error detect function available
- Serial chip select function (ch.6 and ch.7 only)
- Supports high-speed SPI (ch.4 and ch.6 only)
- Data length 5 to 16-bit

**[LIN]**

- LIN protocol Rev.2.1 supported
- Full-duplex double buffer
- Master/Slave mode supported
- LIN break field generation (can change to 13 to 16-bit length)
- LIN break delimiter generation (can change to 1 to 4-bit length)
- Various error detect functions available (parity errors, framing errors, and overrun errors)

**[I<sup>2</sup>C]**

- Standard-mode (Max 100 kbps) / Fast-mode (Max 400 kbps) supported
- Fast-mode Plus (Fm+) (Max 1000 kbps, only for ch.3 = ch.A and ch.7 = ch.B) supported

**DMA Controller (8 channels)**

DMA Controller has an independent bus for CPU, so CPU and DMA Controller can process simultaneously.

- 8 independently configured and operated channels
- Transfer can be started by software or request from the built-in peripherals
- Transfer address area: 32-bit (4 Gbytes)
- Transfer mode: Block transfer/Burst transfer/Demand transfer
- Transfer data type: bytes/half-word/word
- Transfer block count: 1 to 16
- Number of transfers: 1 to 65536

**DSTC (Descriptor System Data Transfer Controller) (128 channels)**

The DSTC can transfer data at high-speed without going via the CPU. The DSTC adopts the Descriptor system and, following the specified contents of the Descriptor which has already been constructed on the memory, can access directly the memory /peripheral device and performs the data transfer operation.

It supports the software activation, the hardware activation and the chain activation functions.

**A/D Converter (Max 24 channels)****[12-bit A/D Converter]**

- Successive Approximation type
- Built-in 3 units
- Conversion time: 0.5  $\mu$ s @ 5 V
- Priority conversion available (priority at 2 levels)
- Scanning conversion mode
- Built-in FIFO for conversion data storage (for SCAN conversion: 16 steps, for Priority conversion: 4 steps)

**DA converter (Max 2 channels)**

- R-2R type
- 12-bit resolution

**Base Timer (Max 8 channels)**

Operation mode is selectable from the followings for each channel.

- 16-bit PWM timer
- 16-bit PPG timer
- 16-/32-bit reload timer
- 16-/32-bit PWC timer

**General Purpose I/O Port**

This series can use its pins as general purpose I/O ports when they are not used for external bus or peripherals. Moreover, the port relocate function is built in. It can set which I/O port the peripheral function can be allocated.

- Capable of pull-up control per pin
- Capable of reading pin level directly
- Built-in the port relocate function
- Up to 100 high-speed general-purpose I/O ports @ 120 pin Package
- Some pin is 5V tolerant I/O.
- See "Pin Description" and "I/O Circuit Type" for the corresponding pins.

## Multi-function Timer (Max 2 units)

The Multi-function timer is composed of the following blocks.

Minimum resolution: 6.25 ns

- 16-bit free-run timer × 3 ch./unit
- Input capture × 4 ch./unit
- Output compare × 6 ch./unit
- A/D activation compare × 6 ch./unit
- Waveform generator × 3 ch./unit
- 16-bit PPG timer × 3 ch./unit

The following function can be used to achieve the motor control.

- PWM signal output function
- DC chopper waveform output function
- Dead time function
- Input capture function
- A/D convertor activate function
- DTIF (Motor emergency stop) interrupt function

## Real-time clock (RTC)

The Real-time clock can count

Year/Month/Day/Hour/Minute/Second/A day of the week from 00 to 99.

- Interrupt function with specifying date and time (Year/Month/Day/Hour/Minute) is available. This function is also available by specifying only Year, Month, Day, Hour or Minute.
- Timer interrupt function after set time or each set time.
- Capable of rewriting the time with continuing the time count.
- Leap year automatic count is available.

## Quadrature Position/Revolution Counter (QPRC) (Max 2 channels)

The Quadrature Position/Revolution Counter (QPRC) is used to measure the position of the position encoder. Moreover, it is possible to use up/down counter.

- The detection edge of the three external event input pins AIN, BIN and ZIN is configurable.
- 16-bit position counter
- 16-bit revolution counter
- Two 16-bit compare registers

## Dual Timer (32-/16-bit Down Counter)

The Dual Timer consists of two programmable 32-/16-bit down counters.

Operation mode is selectable from the followings for each channel.

- Free-running
- Periodic (= Reload)
- One-shot

## Watch Counter

The Watch counter is used for wake up from the low-power consumption mode. It is possible to select the main clock, sub clock, built-in high-speed CR clock or built-in low-speed CR clock as the clock source.

Interval timer: up to 64s (Max) @ Sub Clock: 32.768 kHz

## External Interrupt Controller Unit

- External interrupt input pin: Max 16 pins
- Include one non-maskable interrupt (NMI)

## Watchdog Timer (2 channels)

A watchdog timer can generate interrupts or a reset when a time-out value is reached.

This series consists of two different watchdogs, a "Hardware" watchdog and a "Software" watchdog.

"Hardware" watchdog timer is clocked by low-speed internal CR oscillator. Therefore, "Hardware" watchdog is active in any power saving mode except STOP.

## CRC (Cyclic Redundancy Check) Accelerator

The CRC accelerator helps a verify data transmission or storage integrity.

CCITT CRC16 and IEEE-802.3 CRC32 are supported.

- CCITT CRC16 Generator Polynomial: 0x1021
- IEEE-802.3 CRC32 Generator Polynomial: 0x04C11DB7

## SD Card Interface

It is possible to use the SD card that conforms to the following standards.

- Part 1 Physical Layer Specification version 3.01
- Part E1 SDIO Specification version 3.00
- Part A2 SD Host Controller Standard Specification version 3.00
- 1-bit or 4-bit data bus

## Clock and Reset

### [Clocks]

Five clock sources (2 external oscillators, 2 internal CR oscillator, and Main PLL) that are dynamically selectable.

- Main clock: 4 MHz to 48 MHz
- Sub Clock: 32.768 kHz
- High-speed internal CR Clock: 4 MHz
- Low-speed internal CR Clock: 100 kHz
- Main PLL Clock

### [Resets]

- Reset requests from INITX pin
- Power on reset
- Software reset
- Watchdog timers reset
- Low voltage detector reset
- Clock supervisor reset

### Clock Super Visor (CSV)

Clocks generated by internal CR oscillators are used to supervise abnormality of the external clocks.

- External OSC clock failure (clock stop) is detected, reset is asserted.
- External OSC frequency anomaly is detected, interrupt or reset is asserted.

### Low-Voltage Detector (LVD)

This Series include 2-stage monitoring of voltage on the VCC pins. When the voltage falls below the voltage has been set, Low-Voltage Detector generates an interrupt or reset.

- LVD1: error reporting via interrupt
- LVD2: auto-reset operation

## Low-power Consumption Mode

Six low-power consumption modes are supported.

- SLEEP
- TIMER
- RTC
- STOP
- Deep standby RTC (selectable from with/without RAM retention)
- Deep standby stop (selectable from with/without RAM retention)

## VBAT

The consumption power during the RTC operation can be reduced by supplying the power supply independent from the RTC (calendar circuit)/32 kHz oscillation circuit. The following circuits can also be used.

- RTC
- 32 kHz oscillation circuit
- Power-on circuit
- Back up register: 32 bytes
- Port circuit

## Debug

- Serial Wire JTAG Debug Port (SWJ-DP)
- Embedded Trace Macrocells (ETM) provide comprehensive debug and trace facilities.

## Unique ID

Unique value of the device (41-bit) is set.

## Power Supply

Two Power Supplies

- Wide range voltage: VCC = 2.7 V to 5.5 V
- Power supply for VBAT: VBAT = 2.7 V to 5.5 V

## Contents

<b>1. Product Lineup</b> .....	<b>7</b>
<b>2. Packages</b> .....	<b>8</b>
<b>3. Pin Assignment</b> .....	<b>9</b>
<b>4. Pin Description</b> .....	<b>15</b>
<b>5. I/O Circuit Type</b> .....	<b>43</b>
<b>6. Handling Precautions</b> .....	<b>50</b>
6.1 Precautions for Product Design .....	50
6.2 Precautions for Package Mounting.....	51
6.3 Precautions for Use Environment .....	52
<b>7. Handling Devices</b> .....	<b>53</b>
<b>8. Block Diagram</b> .....	<b>56</b>
<b>9. Memory Size</b> .....	<b>57</b>
<b>10. Memory Map</b> .....	<b>57</b>
<b>11. Pin Status in Each CPU State</b> .....	<b>60</b>
<b>12. Electrical Characteristics</b> .....	<b>67</b>
12.1 Absolute Maximum Ratings.....	67
12.2 Recommended Operating Conditions.....	68
12.3 DC Characteristics.....	71
12.3.1 Current Rating.....	71
12.3.2 Pin Characteristics .....	79
12.4 AC Characteristics.....	81
12.4.1 Main Clock Input Characteristics.....	81
12.4.2 Sub Clock Input Characteristics .....	82
12.4.3 Built-in CR Oscillation Characteristics.....	82
12.4.4 Operating Conditions of Main PLL (In the case of using main clock for input clock of PLL) .....	83
12.4.5 Operating Conditions of Main PLL (In the case of using built-in high-speed CR clock for input clock of main PLL) ....	83
12.4.6 Reset Input Characteristics .....	83
12.4.7 Power-on Reset Timing.....	84
12.4.8 GPIO Output Characteristics.....	84
12.4.9 External Bus Timing .....	85
12.4.10 Base Timer Input Timing.....	96
12.4.11 CSIO/UART Timing .....	97
12.4.12 External Input Timing.....	130
12.4.13 Quadrature Position/Revolution Counter Timing .....	131
12.4.14 I <sup>2</sup> C Timing.....	133
12.4.15 SD Card Interface Timing .....	135
12.4.16 ETM Timing .....	137
12.4.17 JTAG Timing.....	138
12.5 12-bit A/D Converter.....	139
12.6 12-bit D/A Converter.....	142
12.7 Low-Voltage Detection Characteristics.....	143
12.7.1 Low-Voltage Detection Reset.....	143
12.7.2 Interrupt of Low-Voltage Detection.....	143
12.8 MainFlash Memory Write/Erase Characteristics.....	144
12.9 WorkFlash Memory Write/Erase Characteristics .....	144
12.10 Standby Recovery Time .....	145
12.10.1 Recovery cause: Interrupt/WKUP.....	145

12.10.2 Recovery cause: Reset.....	147
<b>13. Ordering Information .....</b>	<b>149</b>
<b>14. Package Dimensions .....</b>	<b>150</b>
<b>15. Major Changes .....</b>	<b>157</b>
<b>Document History.....</b>	<b>158</b>
<b>Sales, Solutions, and Legal Information.....</b>	<b>160</b>

## 1. Product Lineup

### Memory Size

Product name	MB9BF166M/N/R	MB9BF167M/N/R	MB9BF168M/N/R
MainFlash memory	512 Kbytes	768 Kbytes	1024 Kbytes
WorkFlash memory	32 Kbytes	32 Kbytes	32 Kbytes
On-chip SRAM	64 Kbytes	96 Kbytes	128 Kbytes
SRAM0	32 Kbytes	48 Kbytes	64 Kbytes
SRAM1	16 Kbytes	24 Kbytes	32 Kbytes
SRAM1	16 Kbytes	24 Kbytes	32 Kbytes

### Function

Product name		MB9BF166M MB9BF167M MB9BF168M	MB9BF166N MB9BF167N MB9BF168N	MB9BF166R MB9BF167R MB9BF168R
Pin count		80	100/112	120/144
CPU		Cortex-M4F, MPU, NVIC 128ch.		
Freq.		160 MHz		
Power supply voltage range		2.7 V to 5.5 V		
DMAC		8 ch.		
DSTC		128 ch.		
External Bus Interface		Addr:19-bit (Max), R/W data: 8-bit (Max), CS:5 (Max), SRAM, NOR Flash	Addr:25-bit (Max), R/W data: 8-/16-bit (Max), CS:9 (Max), SRAM, NOR Flash, SDRAM	Addr:25-bit (Max), R/W data: 8-/16-bit (Max), CS:9 (Max), SRAM, NOR Flash, NAND Flash, SDRAM
Multi-function Serial Interface (UART/CSIO/LIN/I <sup>2</sup> C)		8 ch. (Max)		
Base Timer (PWC/Reload timer/PWM/PPG)		8 ch. (Max)		
MF Timer	A/D activation compare	6 ch.		
	Input capture	4 ch.		
	Free-run timer	3 ch.		
	Output compare	6 ch.		
	Waveform generator	3 ch.		
PPG	3 ch.			
SD Card Interface		1 unit		
QPRC		2 ch. (Max)		
Dual Timer		1 unit		
Real-Time Clock		1 unit		
Watch Counter		1 unit		
CRC Accelerator		Yes		
Watchdog Timer		1 ch. (SW) + 1 ch. (HW)		
External Interrupts		16 pins (Max) + NMI × 1		
I/O Ports		63 pins (Max)	80 pins (Max)	100 pins (Max)
12-bit A/D Converter		16 ch. (3 units)	24 ch. (3 units)	
12-bit D/A Converter		2 units (Max)		
CSV (Clock Super Visor)		Yes		
LVD (Low-Voltage Detector)		2 ch.		
Built-in CR	High-speed	4 MHz		
	Low-speed	100 kHz		
Debug Function		SWJ-DP/ETM		
Unique ID		Yes		

#### Notes:

- All signals of the peripheral function in each product cannot be allocated by limiting the pins of package. It is necessary to use the port relocate function of the I/O port according to your function use.
- See “12. Electrical Characteristics 12.4. AC Characteristics 12.4.3. Built-in CR Oscillation Characteristics” for accuracy of built-in CR.

## 2. Packages

Package	Product name	MB9BF166M MB9BF167M MB9BF168M	MB9BF166N MB9BF167N MB9BF168N	MB9BF166R MB9BF167R MB9BF168R
LQFP: LQH080 (0.5 mm pitch)		○	-	-
LQFP: LQJ080 (0.65 mm pitch)		○	-	-
QFP: PQH100 (0.65 mm pitch)		-	○	-
LQFP: LQI100 (0.5 mm pitch)		-	○	-
LQFP: LQM120 (0.5 mm pitch)		-	-	○
BGA: LDC112 (0.5 mm pitch)		-	○	-
BGA: LDC144 (0.5 mm pitch)		-	-	○

○: Supported

**Note:**

- See "Package Dimensions" for detailed information on each package.

### 3. Pin Assignment

#### LQH080/LQJ080

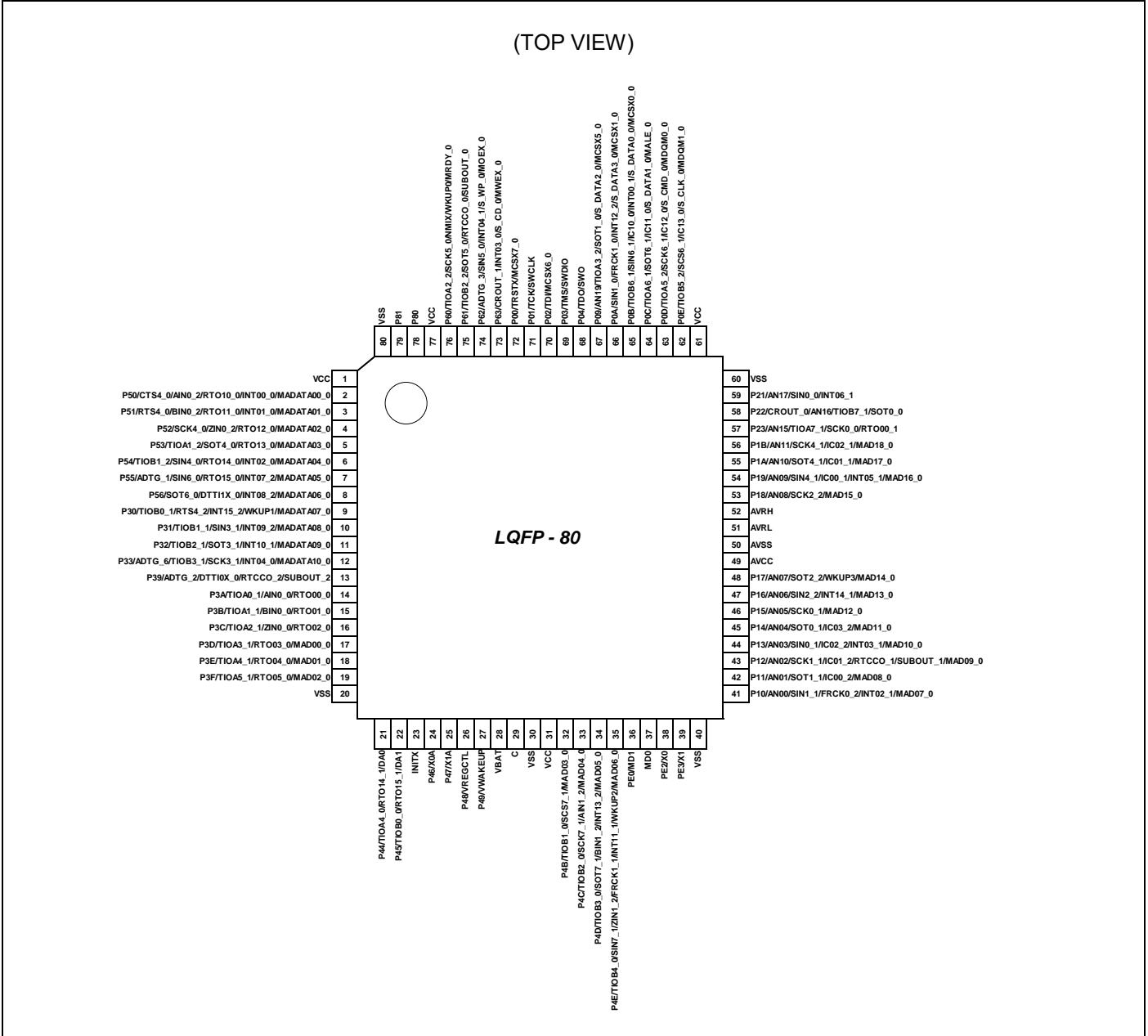

**Note:**

- The number after the underscore (“\_”) in pin names such as XXX\_1 and XXX\_2 indicates the relocated port number. For these pins, there are multiple pins that provide the same function for the same channel. Use the extended port function register (EPFR) to select the pin.

LQI100

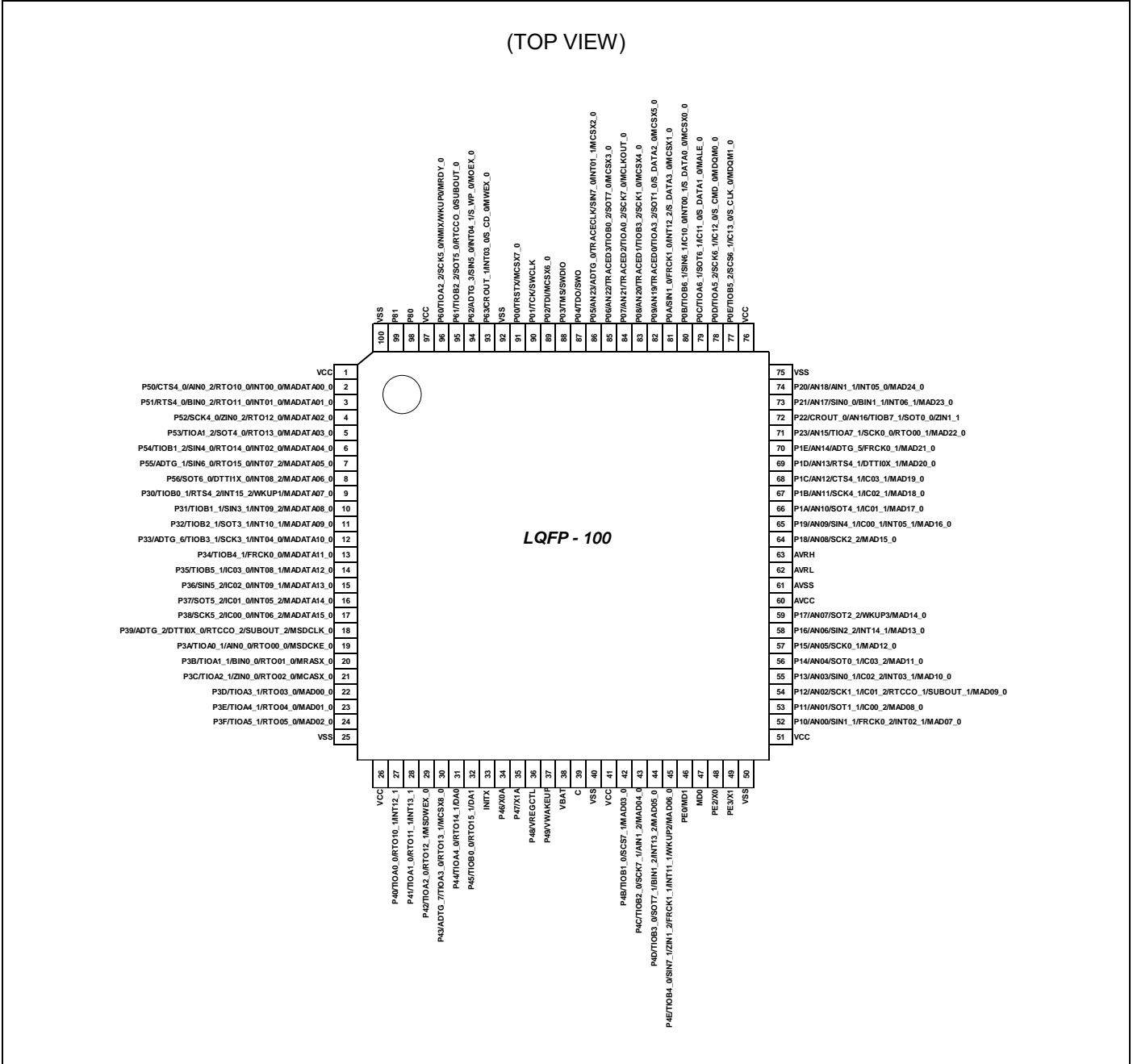

**Note:**

- The number after the underscore (“\_”) in pin names such as XXX\_1 and XXX\_2 indicates the relocated port number. For these pins, there are multiple pins that provide the same function for the same channel. Use the extended port function register (EPFR) to select the pin.

## LQM120

(TOP VIEW)

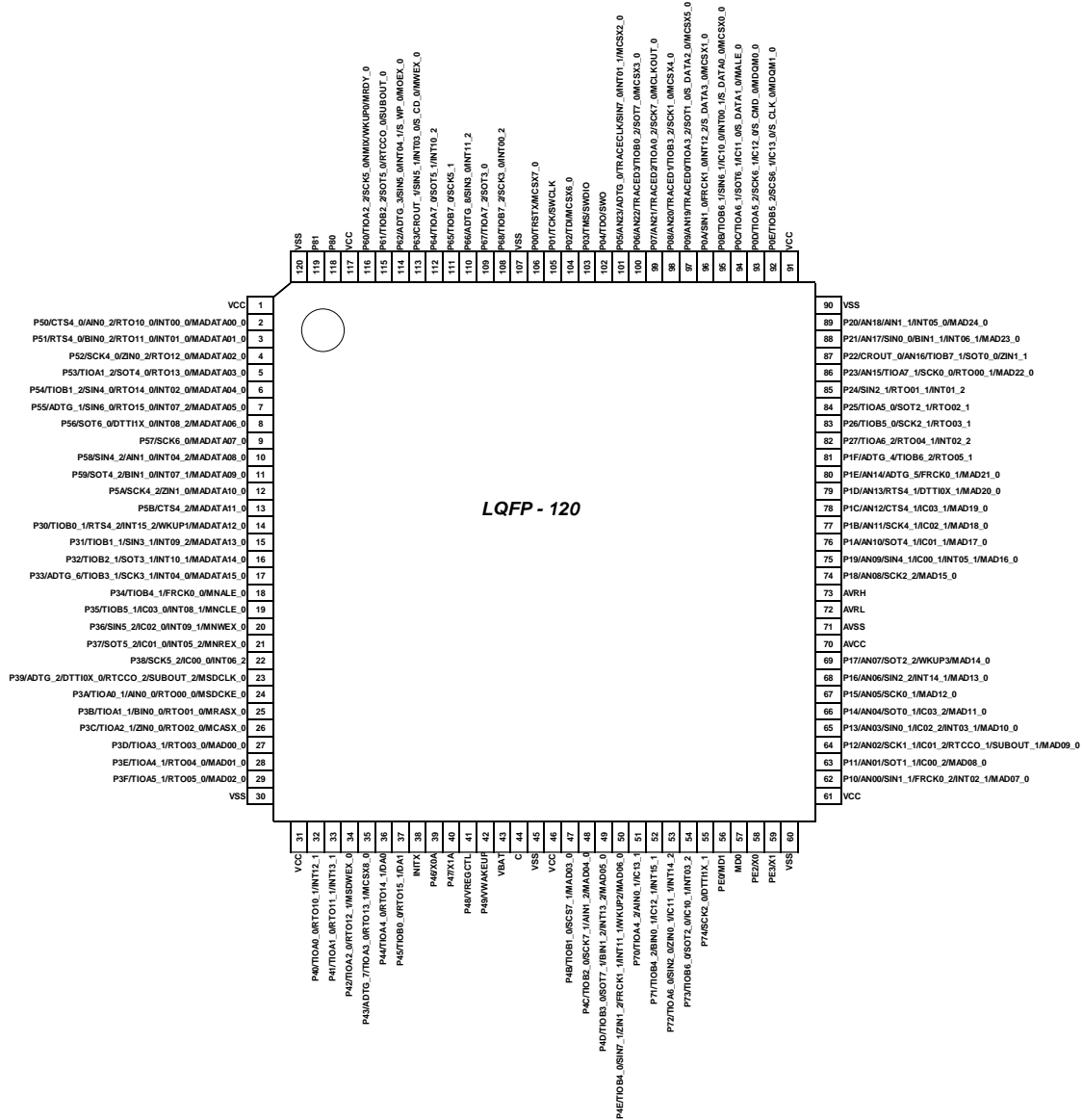

**Note:**

- The number after the underscore (“\_”) in pin names such as XXX\_1 and XXX\_2 indicates the relocated port number. For these pins, there are multiple pins that provide the same function for the same channel. Use the extended port function register (EPFR) to select the pin.

## PQH100

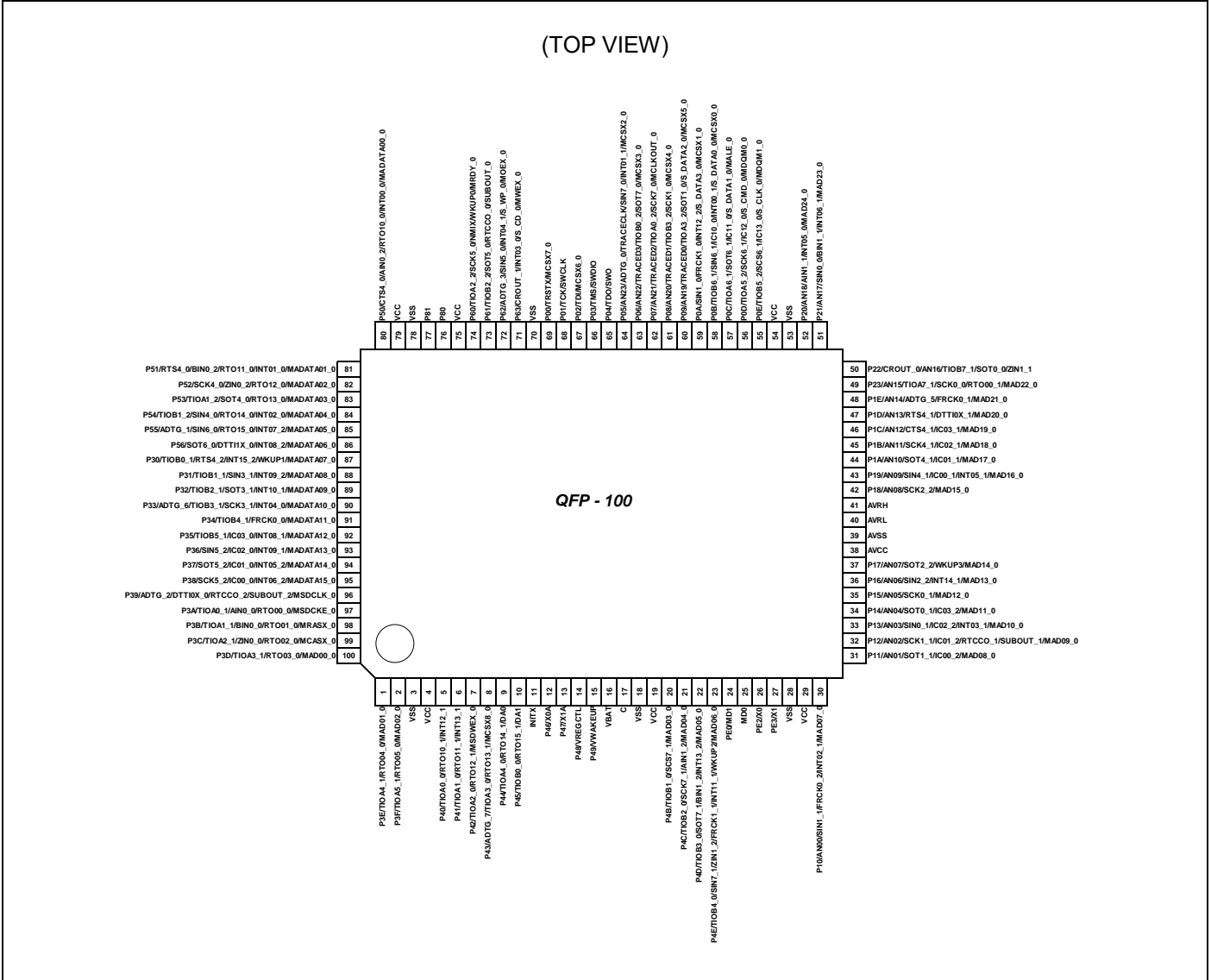

**Note:**

- The number after the underscore (“\_”) in pin names such as XXX\_1 and XXX\_2 indicates the relocated port number. For these pins, there are multiple pins that provide the same function for the same channel. Use the extended port function register (EPFR) to select the pin.

LDC112

(TOP VIEW)

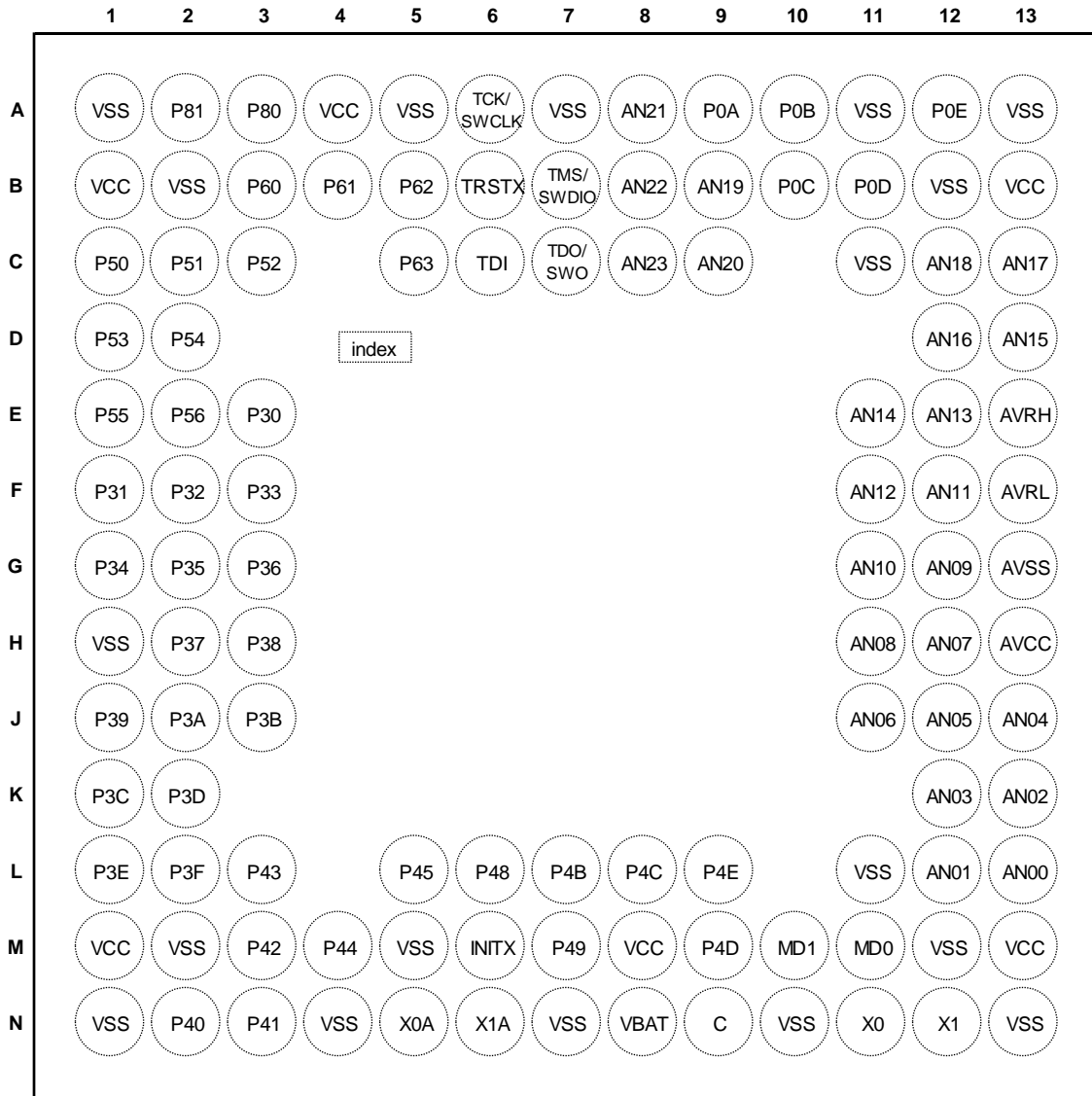

**Note:**

- The number after the underscore (“\_”) in pin names such as XXX\_1 and XXX\_2 indicates the relocated port number. For these pins, there are multiple pins that provide the same function for the same channel. Use the extended port function register (EPFR) to select the pin.

LDC144

(TOP VIEW)

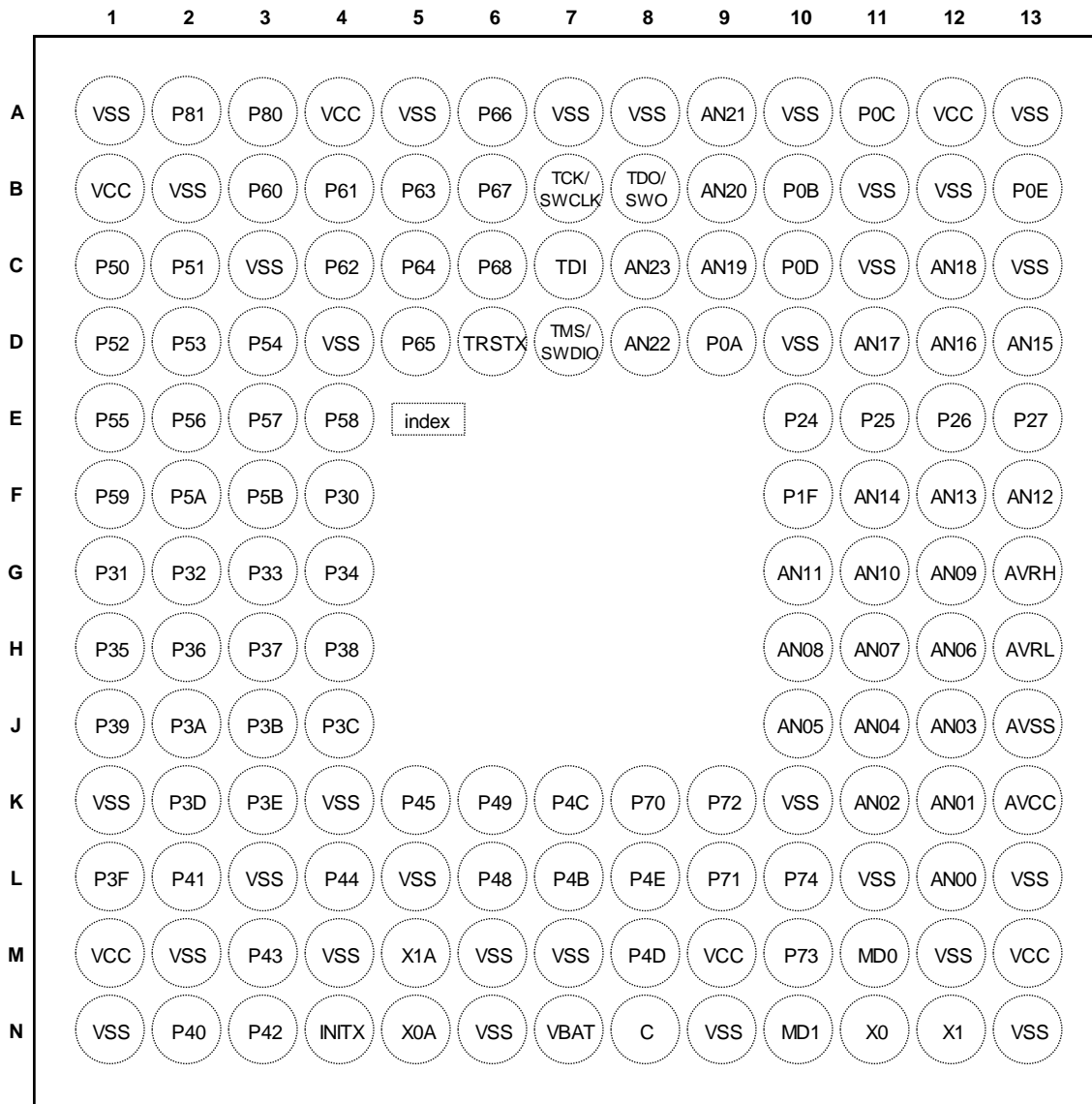

**Note:**

- The number after the underscore (“\_”) in pin names such as XXX\_1 and XXX\_2 indicates the relocated port number. For these pins, there are multiple pins that provide the same function for the same channel. Use the extended port function register (EPFR) to select the pin.

## 4. Pin Description

### List of pin numbers

The number after the underscore (“\_”) in pin names such as XXX\_1 and XXX\_2 indicates the relocated port number. For these pins, there are multiple pins that provide the same function for the same channel. Use the extended port function register (EPFR) to select the pin.

Pin No						Pin Name	I/O circuit type	Pin state type
LQFP120	LQFP100	LQFP80	QFP100	BGA112	BGA144			
1	1	1	79	B1	B1	VCC	-	-
2	2	2	80	C1	C1	P50	E	K
						CTS4_0		
						AIN0_2		
						RTO10_0 (PPG10_0)		
						INT00_0		
MADATA00_0								
3	3	3	81	C2	C2	P51	E	K
						RTS4_0		
						BIN0_2		
						RTO11_0 (PPG10_0)		
						INT01_0		
MADATA01_0								
4	4	4	82	C3	D1	P52	E	I
						SCK4_0 (SCL4_0)		
						ZIN0_2		
						RTO12_0 (PPG12_0)		
MADATA02_0								
5	5	5	83	D1	D2	P53	E	I
						TIOA1_2		
						SOT4_0 (SDA4_0)		
						RTO13_0 (PPG12_0)		
MADATA03_0								
6	6	6	84	D2	D3	P54	E	K
						TIOB1_2		
						SIN4_0		
						RTO14_0 (PPG14_0)		
INT02_0								
MADATA04_0								
7	7	7	85	E1	E1	P55	E	K
						ADTG_1		
						SIN6_0		
						RTO15_0 (PPG14_0)		
						INT07_2		
MADATA05_0								

Pin No						Pin Name	I/O circuit type	Pin state type
LQFP120	LQFP100	LQFP80	QFP100	BGA112	BGA144			
8	8	8	86	E2	E2	P56	E	K
						SOT6_0 (SDA6_0)		
						DTTI1X_0		
						INT08_2		
						MADATA06_0		
9	-	-	-	-	E3	P57	E	I
						SCK6_0 (SCL6_0)		
						MADATA07_0		
10	-	-	-	-	E4	P58	E	K
						SIN4_2		
						AIN1_0		
						INT04_2		
						MADATA08_0		
11	-	-	-	-	F1	P59	E	K
						SOT4_2 (SDA4_2)		
						BIN1_0		
						INT07_1		
						MADATA09_0		
12	-	-	-	-	F2	P5A	E	I
						SCK4_2 (SCL4_2)		
						ZIN1_0		
						MADATA10_0		
13	-	-	-	-	F3	P5B	E	I
						CTS4_2		
						MADATA11_0		
14	9	9	87	E3	F4	P30	E	Q
						TIOB0_1		
						RTS4_2		
						INT15_2		
						WKUP1		
-						MADATA07_0		
14	-	-	-	-	F4	MADATA12_0		
15	10	10	88	F1	G1	P31	I	K
						TIOB1_1		
						SIN3_1		
						INT09_2		
						MADATA08_0		
-						MADATA13_0		
15	-	-	-	-	G1	MADATA13_0		

Pin No						Pin Name	I/O circuit type	Pin state type
LQFP120	LQFP100	LQFP80	QFP100	BGA112	BGA144			
16	11	11	89	F2	G2	P32	N	K
						TIOB2_1		
						SOT3_1 (SDA3_1)		
						INT10_1		
-	-	-	-	-	-	MADATA09_0		
16	-	-	-	-	G2	MADATA14_0		
17	12	12	90	F3	G3	P33	N	K
						ADTG_6		
						TIOB3_1		
						SCK3_1 (SCL3_1)		
						INT04_0		
-	-	-	-	-	-	MADATA10_0		
17	-	-	-	-	G3	MADATA15_0		
18	13	-	91	G1	G4	P34	E	I
						TIOB4_1		
						FRCK0_0		
-	-	-	-	-	-	MADATA11_0		
18	-	-	-	-	G4	MNALE_0		
19	14	-	92	G2	H1	P35	E	K
						TIOB5_1		
						IC03_0		
						INT08_1		
						-		
19	-	-	-	-	H1	MNCLE_0		

Pin No						Pin Name	I/O circuit type	Pin state type
LQFP120	LQFP100	LQFP80	QFP100	BGA112	BGA144			
20	15	-	93	G3	H2	P36	E	K
						SIN5_2		
						IC02_0		
						INT09_1		
-	-	-	-	-	-	MADATA13_0		
20	-	-	-	-	H2	MNWEX_0		
21	16	-	94	H2	H3	P37	E	K
						SOT5_2 (SDA5_2)		
						IC01_0		
						INT05_2		
-	-	-	-	-	-	MADATA14_0		
21	-	-	-	-	H3	MNREX_0		
22	17	-	95	H3	H4	P38	E	K
						SCK5_2 (SCL5_2)		
						IC00_0		
						INT06_2		
-	-	-	-	-	-	MADATA15_0		
23	18	13	96	J1	J1	P39	L	I
		-						
		ADTG_2						
		DTTIOX_0						
		RTCCO_2						
SUBOUT_2								
-	-	-	-	-	-	MSDCLK_0		
24	19	14	97	J2	J2	P3A	G	I
		-						
		TIOA0_1						
		AIN0_0						
RTO00_0 (PPG00_0)								
-	-	-	-	-	-	MSDCKE_0		
25	20	15	98	J3	J3	P3B	G	I
		-						
		TIOA1_1						
		BIN0_0						
RTO01_0 (PPG00_0)								
-	-	-	-	-	-	MRASX_0		

Pin No						Pin Name	I/O circuit type	Pin state type
LQFP120	LQFP100	LQFP80	QFP100	BGA112	BGA144			
26	21	16	99	K1	J4	P3C	G	I
						TIOA2_1		
						ZIN0_0		
						RTO02_0 (PPG02_0)		
		-	MCASX_0					
27	22	17	100	K2	K2	P3D	G	I
						TIOA3_1		
						RTO03_0 (PPG02_0)		
						MAD00_0		
28	23	18	1	L1	K3	P3E	G	I
						TIOA4_1		
						RTO04_0 (PPG04_0)		
						MAD01_0		
29	24	19	2	L2	L1	P3F	G	I
						TIOA5_1		
						RTO05_0 (PPG04_0)		
						MAD02_0		
30	25	20	3	N1	N1	VSS	-	-
31	26	-	4	M1	M1	VCC	-	-
32	27	-	5	N2	N2	P40	G	K
						TIOA0_0		
						RTO10_1 (PPG10_1)		
						INT12_1		
33	28	-	6	N3	L2	P41	G	K
						TIOA1_0		
						RTO11_1 (PPG10_1)		
						INT13_1		
34	29	-	7	M3	N3	P42	G	I
						TIOA2_0		
						RTO12_1 (PPG12_1)		
						MSDWEX_0		
35	30	-	8	L3	M3	P43	G	I
						ADTG_7		
						TIOA3_0		
						RTO13_1 (PPG12_1)		
						MCSX8_0		

Pin No						Pin Name	I/O circuit type	Pin state type
LQFP120	LQFP100	LQFP80	QFP100	BGA112	BGA144			
36	31	21	9	M4	L4	P44	R	J
						TIOA4_0		
						RTO14_1 (PPG14_1)		
						DA0		
37	32	22	10	L5	K5	P45	R	J
						TIOB0_0		
						RTO15_1 (PPG14_1)		
						DA1		
38	33	23	11	M6	N4	INITX	B	C
39	34	24	12	N5	N5	P46	P	S
						X0A		
40	35	25	13	N6	M5	P47	Q	T
						X1A		
41	36	26	14	L6	L6	P48	O	U
						VREGCTL		
42	37	27	15	M7	K6	P49	O	U
						VWAKEUP		
43	38	28	16	N8	N7	VBAT	-	-
44	39	29	17	N9	N8	C	-	-
45	40	30	18	N10	N9	VSS	-	-
46	41	31	19	M8	M9	VCC	-	-
47	42	32	20	L7	L7	P4B	E	I
						TIOB1_0		
						SCS7_1		
						MAD03_0		
48	43	33	21	L8	K7	P4C	N	I
						TIOB2_0		
						SCK7_1 (SCL7_1)		
						AIN1_2		
						MAD04_0		
49	44	34	22	M9	M8	P4D	N	K
						TIOB3_0		
						SOT7_1 (SDA7_1)		
						BIN1_2		
						INT13_2		
						MAD05_0		
50	45	35	23	L9	L8	P4E	I	Q
						TIOB4_0		
						SIN7_1		
						ZIN1_2		
						FRCK1_1		
						INT11_1		
						WKUP2		
						MAD06_0		

Pin No						Pin Name	I/O circuit type	Pin state type
LQFP120	LQFP100	LQFP80	QFP100	BGA112	BGA144			
51	-	-	-	-	K8	P70	E	I
						TIOA4_2		
						AIN0_1		
						IC13_1		
52	-	-	-	-	L9	P71	E	K
						TIOB4_2		
						BIN0_1		
						IC12_1		
53	-	-	-	-	K9	P72	E	K
						TIOA6_0		
						SIN2_0		
						ZIN0_1		
						IC11_1		
INT14_2								
54	-	-	-	-	M10	P73	E	K
						TIOB6_0		
						SOT2_0 (SDA2_0)		
						IC10_1		
55	-	-	-	-	L10	P74	E	I
						SCK2_0 (SCL2_0)		
						DTT11X_1		
56	46	36	24	M10	N10	PE0	C	E
						MD1		
57	47	37	25	M11	M11	MD0	J	D
58	48	38	26	N11	N11	PE2	A	A
						X0		
59	49	39	27	N12	N12	PE3	A	B
						X1		
60	50	40	28	N13	N13	VSS	-	-
61	51	-	29	M13	M13	VCC	-	-
62	52	41	30	L13	L12	P10	F	M
						AN00		
						SIN1_1		
						FRCK0_2		
						INT02_1		
MAD07_0								
63	53	42	31	L12	K12	P11	F	L
						AN01		
						SOT1_1 (SDA1_1)		
						IC00_2		
						MAD08_0		

Pin No						Pin Name	I/O circuit type	Pin state type
LQFP120	LQFP100	LQFP80	QFP100	BGA112	BGA144			
64	54	43	32	K13	K11	P12	F	L
						AN02		
						SCK1_1 (SCL1_1)		
						IC01_2		
						RTCCO_1		
						SUBOUT_1		
MAD09_0								
65	55	44	33	K12	J12	P13	F	M
						AN03		
						SIN0_1		
						IC02_2		
						INT03_1		
MAD10_0								
66	56	45	34	J13	J11	P14	F	L
						AN04		
						SOT0_1 (SDA0_1)		
						IC03_2		
MAD11_0								
67	57	46	35	J12	J10	P15	F	L
						AN05		
						SCK0_1 (SCL0_1)		
						MAD12_0		
68	58	47	36	J11	H12	P16	F	M
						AN06		
						SIN2_2		
						INT14_1		
MAD13_0								
69	59	48	37	H12	H11	P17	F	P
						AN07		
						SOT2_2 (SDA2_2)		
						WKUP3		
MAD14_0								
70	60	49	38	H13	K13	AVCC	-	-
71	61	50	39	G13	J13	AVSS	-	-
72	62	51	40	F13	H13	AVRL	-	-
73	63	52	41	E13	G13	AVRH	-	-
74	64	53	42	H11	H10	P18	F	L
						AN08		
						SCK2_2 (SCL2_2)		
						MAD15_0		

Pin No						Pin Name	I/O circuit type	Pin state type
LQFP120	LQFP100	LQFP80	QFP100	BGA112	BGA144			
75	65	54	43	G12	G12	P19	F	M
						AN09		
						SIN4_1		
						IC00_1		
						INT05_1		
MAD16_0								
76	66	55	44	G11	G11	P1A	M	L
						AN10		
						SOT4_1 (SDA4_1)		
						IC01_1		
MAD17_0								
77	67	56	45	F12	G10	P1B	M	L
						AN11		
						SCK4_1 (SCL4_1)		
						IC02_1		
MAD18_0								
78	68	-	46	F11	F13	P1C	F	L
						AN12		
						CTS4_1		
						IC03_1		
MAD19_0								
79	69	-	47	E12	F12	P1D	F	L
						AN13		
						RTS4_1		
						DTTIOX_1		
MAD20_0								
80	70	-	48	E11	F11	P1E	F	L
						AN14		
						ADTG_5		
						FRCK0_1		
MAD21_0								
81	-	-	-	-	F10	P1F	E	I
						ADTG_4		
						TIOB6_2		
						RTO05_1 (PPG04_1)		
82	-	-	-	-	E13	P27	E	K
						TIOA6_2		
						RTO04_1 (PPG04_1)		
						INT02_2		

Pin No						Pin Name	I/O circuit type	Pin state type
LQFP120	LQFP100	LQFP80	QFP100	BGA112	BGA144			
83	-	-	-	-	E12	P26	E	I
						TIOB5_0		
						SCK2_1 (SCL2_1)		
						RTO03_1 (PPG02_1)		
84	-	-	-	-	E11	P25	E	I
						TIOA5_0		
						SOT2_1 (SDA2_1)		
						RTO02_1 (PPG02_1)		
85	-	-	-	-	E10	P24	E	K
						SIN2_1		
						RTO01_1 (PPG00_1)		
						INT01_2		
86	71	57	49	D13	D13	P23	F	L
		-						
		AN15						
		TIOA7_1						
		SCK0_0 (SCL0_0)						
		RTO00_1 (PPG00_1)						
MAD22_0								
87	72	58	50	D12	D12	P22	F	L
		-						
		CROUT_0						
		AN16						
		TIOB7_1						
		SOT0_0 (SDA0_0)						
ZIN1_1								
88	73	59	51	C13	D11	P21	F	M
		-						
		AN17						
		SIN0_0						
		BIN1_1						
		INT06_1						
MAD23_0								
89	74	-	52	C12	C12	P20	F	M
		-						
		AN18						
		AIN1_1						
		INT05_0						
MAD24_0								
90	75	60	53	A13	A13	VSS	-	-
91	76	61	54	B13	A12	VCC	-	-

Pin No						Pin Name	I/O circuit type	Pin state type
LQFP120	LQFP100	LQFP80	QFP100	BGA112	BGA144			
92	77	62	55	A12	B13	P0E	L	I
						TIOB5_2		
						SCS6_1		
						IC13_0		
						S_CLK_0		
MDQM1_0								
93	78	63	56	B11	C10	P0D	L	I
						TIOA5_2		
						SCK6_1 (SCL6_1)		
						IC12_0		
						S_CMD_0		
MDQM0_0								
94	79	64	57	B10	A11	P0C	L	I
						TIOA6_1		
						SOT6_1 (SDA6_1)		
						IC11_0		
						S_DATA1_0		
MALE_0								
95	80	65	58	A10	B10	P0B	L	K
						TIOB6_1		
						SIN6_1		
						IC10_0		
						INT00_1		
						S_DATA0_0		
MCSX0_0								
96	81	66	59	A9	D9	P0A	L	K
						SIN1_0		
						FRCK1_0		
						INT12_2		
						S_DATA3_0		
MCSX1_0								
97	82	67	60	B9	C9	P09	M	N
		-						
		TRACED0						
		TIOA3_2						
		SOT1_0 (SDA1_0)						
		S_DATA2_0						
MCSX5_0								
98	83	-	61	C9	B9	P08	F	N
		AN20						
		TRACED1						
		TIOB3_2						
		SCK1_0 (SCL1_0)						
MCSX4_0								

Pin No						Pin Name	I/O circuit type	Pin state type
LQFP120	LQFP100	LQFP80	QFP100	BGA112	BGA144			
99	84	-	62	A8	A9	P07	F	N
						AN21		
						TRACED2		
						TIOA0_2		
						SCK7_0 (SCL7_0)		
MCLKOUT_0								
100	85	-	63	B8	D8	P06	F	N
						AN22		
						TRACED3		
						TIOB0_2		
						SOT7_0 (SDA7_0)		
MCSX3_0								
101	86	-	64	C8	C8	P05	F	O
						AN23		
						ADTG_0		
						TRACECLK		
						SIN7_0		
INT01_1								
MCSX2_0								
102	87	68	65	C7	B8	P04	E	G
						TDO		
						SWO		
103	88	69	66	B7	D7	P03	E	G
						TMS		
						SWDIO		
104	89	70	67	C6	C7	P02	E	H
						TDI		
						MCSX6_0		
105	90	71	68	A6	B7	P01	E	G
						TCK		
						SWCLK		
106	91	72	69	B6	D6	P00	E	H
						TRSTX		
						MCSX7_0		
107	92	-	70	A5	A7	VSS	-	-
108	-	-	-	-	C6	P68	E	K
						TIOB7_2		
						SCK3_0 (SCL3_0)		
						INT00_2		
109	-	-	-	-	B6	P67	E	I
						TIOA7_2		
						SOT3_0 (SDA3_0)		

Pin No						Pin Name	I/O circuit type	Pin state type
LQFP120	LQFP100	LQFP80	QFP100	BGA112	BGA144			
110	-	-	-	-	A6	P66	E	K
						ADTG_8		
						SIN3_0		
						INT11_2		
111	-	-	-	-	D5	P65	E	I
						TIOB7_0		
						SCK5_1 (SCL5_1)		
112	-	-	-	-	C5	P64	E	K
						TIOA7_0		
						SOT5_1 (SDA5_1)		
						INT10_2		
113	93	73	71	C5	B5	P63	E	K
	-	-	-	-		CROUT_1		
	-	-	-	-		SIN5_1		
	-	-	-	-		INT03_0		
	93	73	71	C5		S_CD_0		
114	94	74	72	B5	C4	P62	I	K
						ADTG_3		
						SIN5_0		
						INT04_1		
						S_WP_0		
						MOEX_0		
115	95	75	73	B4	B4	P61	E	I
						TIOB2_2		
						SOT5_0 (SDA5_0)		
						RTCCO_0		
						SUBOUT_0		
116	96	76	74	B3	B3	P60	I	F
						TIOA2_2		
						SCK5_0 (SCL5_0)		
						NMIX		
						WKUP0		
						MRDY_0		
117	97	77	75	A4	A4	VCC	-	-
118	98	78	76	A3	A3	P80	H	R
119	99	79	77	A2	A2	P81	H	R

Pin No						Pin Name	I/O circuit type	Pin state type
LQFP120	LQFP100	LQFP80	QFP100	BGA112	BGA144			
120	100	80	78	A1	A1	VSS	-	-
-	-	-	-	A7	A5		-	-
-	-	-	-	B2	A8		-	-
-	-	-	-	B12	A10		-	-
-	-	-	-	C11	B2		-	-
-	-	-	-	H1	B11		-	-
-	-	-	-	N4	B12		-	-
-	-	-	-	M5	C3		-	-
-	-	-	-	N7	C11		-	-
-	-	-	-	L11	C13		-	-
-	-	-	-	A11	D4		-	-
-	-	-	-	M12	D10		-	-
-	-	-	-	M2	K1		-	-
-	-	-	-	-	K4		-	-
-	-	-	-	-	K10		-	-
-	-	-	-	-	L3		-	-
-	-	-	-	-	L5		-	-
-	-	-	-	-	L11		-	-
-	-	-	-	-	L13		-	-
-	-	-	-	-	M2		-	-
-	-	-	-	-	M4		-	-
-	-	-	-	-	M6		-	-
-	-	-	-	-	M7		-	-
-	-	-	-	-	M12		-	-
-	-	-	-	-	N6		-	-

## List of pin functions

The number after the underscore (“\_”) in pin names such as XXX\_1 and XXX\_2 indicates the relocated port number. For these pins, there are multiple pins that provide the same function for the same channel. Use the extended port function register (EPFR) to select the pin.

Pin function	Pin name	Function description	Pin No					
			LQFP 120	LQFP 100	LQFP 80	QFP 100	BGA 112	BGA 144
ADC	ADTG_0	A/D converter external trigger input pin	101	86	-	64	C8	C8
	ADTG_1		7	7	7	85	E1	E1
	ADTG_2		23	18	13	96	J1	J1
	ADTG_3		114	94	74	72	B5	C4
	ADTG_4		81	-	-	-	-	F10
	ADTG_5		80	70	-	48	E11	F11
	ADTG_6		17	12	12	90	F3	G3
	ADTG_7		35	30	-	8	L3	M3
	ADTG_8	110	-	-	-	-	A6	
	AN00	A/D converter analog input pin. Anxx describes ADC ch.xx.	62	52	41	30	L13	L12
	AN01		63	53	42	31	L12	K12
	AN02		64	54	43	32	K13	K11
	AN03		65	55	44	33	K12	J12
	AN04		66	56	45	34	J13	J11
	AN05		67	57	46	35	J12	J10
	AN06		68	58	47	36	J11	H12
	AN07		69	59	48	37	H12	H11
	AN08		74	64	53	42	H11	H10
	AN09		75	65	54	43	G12	G12
	AN10		76	66	55	44	G11	G11
	AN11		77	67	56	45	F12	G10
	AN12		78	68	-	46	F11	F13
	AN13		79	69	-	47	E12	F12
	AN14		80	70	-	48	E11	F11
	AN15		86	71	57	49	D13	D13
	AN16		87	72	58	50	D12	D12
	AN17		88	73	59	51	C13	D11
	AN18		89	74	-	52	C12	C12
	AN19		97	82	67	60	B9	C9
	AN20		98	83	-	61	C9	B9
	AN21		99	84	-	62	A8	A9
	AN22		100	85	-	63	B8	D8
AN23	101		86	-	64	C8	C8	
Base Timer 0	TIOA0_0	Base timer ch.0 TIOA pin	32	27	-	5	N2	N2
	TIOA0_1		24	19	14	97	J2	J2
	TIOA0_2	99	84	-	62	A8	A9	
	TIOB0_0	Base timer ch.0 TIOB pin	37	32	22	10	L5	K5
	TIOB0_1		14	9	9	87	E3	F4
TIOB0_2	100	85	-	63	B8	D8		
Base Timer 1	TIOA1_0	Base timer ch.1 TIOA pin	33	28	-	6	N3	L2
	TIOA1_1		25	20	15	98	J3	J3
	TIOA1_2	5	5	5	83	D1	D2	
	TIOB1_0	Base timer ch.1 TIOB pin	47	42	32	20	L7	L7
	TIOB1_1		15	10	10	88	F1	G1
TIOB1_2	6	6	6	84	D2	D3		
Base Timer 2	TIOA2_0	Base timer ch.2 TIOA pin	34	29	-	7	M3	N3
	TIOA2_1		26	21	16	99	K1	J4
	TIOA2_2	116	96	76	74	B3	B3	
	TIOB2_0	Base timer ch.2 TIOB pin	48	43	33	21	L8	K7
	TIOB2_1		16	11	11	89	F2	G2
TIOB2_2	115	95	75	73	B4	B4		

Pin function	Pin name	Function description	Pin No					
			LQFP 120	LQFP 100	LQFP 80	QFP 100	BGA 112	BGA 144
Base Timer 3	TIOA3_0	Base timer ch.3 TIOA pin	35	30	-	8	L3	M3
	TIOA3_1		27	22	17	100	K2	K2
	TIOA3_2		97	82	67	60	B9	C9
	TIOB3_0	Base timer ch.3 TIOB pin	49	44	34	22	M9	M8
	TIOB3_1		17	12	12	90	F3	G3
	TIOB3_2		98	83	-	61	C9	B9
Base Timer 4	TIOA4_0	Base timer ch.4 TIOA pin	36	31	21	9	M4	L4
	TIOA4_1		28	23	18	1	L1	K3
	TIOA4_2		51	-	-	-	-	K8
	TIOB4_0	Base timer ch.4 TIOB pin	50	45	35	23	L9	L8
	TIOB4_1		18	13	-	91	G1	G4
	TIOB4_2		52	-	-	-	-	L9
Base Timer 5	TIOA5_0	Base timer ch.5 TIOA pin	84	-	-	-	-	E11
	TIOA5_1		29	24	19	2	L2	L1
	TIOA5_2		93	78	63	56	B11	C10
	TIOB5_0	Base timer ch.5 TIOB pin	83	-	-	-	-	E12
	TIOB5_1		19	14	-	92	G2	H1
	TIOB5_2		92	77	62	55	A12	B13
Base Timer 6	TIOA6_0	Base timer ch.6 TIOA pin	53	-	-	-	-	K9
	TIOA6_1		94	79	64	57	B10	A11
	TIOA6_2		82	-	-	-	-	E13
	TIOB6_0	Base timer ch.6 TIOB pin	54	-	-	-	-	M10
	TIOB6_1		95	80	65	58	A10	B10
	TIOB6_2		81	-	-	-	-	F10
Base Timer 7	TIOA7_0	Base timer ch.7 TIOA pin	112	-	-	-	-	C5
	TIOA7_1		86	71	57	49	D13	D13
	TIOA7_2		109	-	-	-	-	B6
	TIOB7_0	Base timer ch.7 TIOB pin	111	-	-	-	-	D5
	TIOB7_1		87	72	58	50	D12	D12
	TIOB7_2		108	-	-	-	-	C6
Debugger	SWCLK	Serial wire debug interface clock input pin	105	90	71	68	A6	B7
	SWDIO	Serial wire debug interface data input / output pin	103	88	69	66	B7	D7
	SWO	Serial wire viewer output pin	102	87	68	65	C7	B8
	TCK	JTAG test clock input pin	105	90	71	68	A6	B7
	TDI	JTAG test data input pin	104	89	70	67	C6	C7
	TDO	JTAG debug data output pin	102	87	68	65	C7	B8
	TMS	JTAG test mode state input/output pin	103	88	69	66	B7	D7
	TRACECLK	Trace CLK output pin of ETM	101	86	-	64	C8	C8
	TRACED0	Trace data output pin of ETM	97	82	-	60	B9	C9
	TRACED1		98	83	-	61	C9	B9
	TRACED2		99	84	-	62	A8	A9
	TRACED3		100	85	-	63	B8	D8
	TRSTX		JTAG test reset Input pin	106	91	72	69	B6

Pin function	Pin name	Function description	Pin No					
			LQFP 120	LQFP 100	LQFP 80	QFP 100	BGA 112	BGA 144
External Bus	MAD00_0	External bus interface address bus	27	22	17	100	K2	K2
	MAD01_0		28	23	18	1	L1	K3
	MAD02_0		29	24	19	2	L2	L1
	MAD03_0		47	42	32	20	L7	L7
	MAD04_0		48	43	33	21	L8	K7
	MAD05_0		49	44	34	22	M9	M8
	MAD06_0		50	45	35	23	L9	L8
	MAD07_0		62	52	41	30	L13	L12
	MAD08_0		63	53	42	31	L12	K12
	MAD09_0		64	54	43	32	K13	K11
	MAD10_0		65	55	44	33	K12	J12
	MAD11_0		66	56	45	34	J13	J11
	MAD12_0		67	57	46	35	J12	J10
	MAD13_0		68	58	47	36	J11	H12
	MAD14_0		69	59	48	37	H12	H11
	MAD15_0		74	64	53	42	H11	H10
	MAD16_0		75	65	54	43	G12	G12
	MAD17_0		76	66	55	44	G11	G11
	MAD18_0		77	67	56	45	F12	G10
	MAD19_0		78	68	-	46	F11	F13
	MAD20_0		79	69	-	47	E12	F12
	MAD21_0		80	70	-	48	E11	F11
	MAD22_0		86	71	-	49	D13	D13
	MAD23_0		88	73	-	51	C13	D11
MAD24_0	89	74	-	52	C12	C12		

Pin function	Pin name	Function description	Pin No					
			LQFP 120	LQFP 100	LQFP 80	QFP 100	BGA 112	BGA 144
External Bus	MCSX0_0	External bus interface chip select output pin	95	80	65	58	A10	B10
	MCSX1_0		96	81	66	59	A9	D9
	MCSX2_0		101	86	-	64	C8	C8
	MCSX3_0		100	85	-	63	B8	D8
	MCSX4_0		98	83	-	61	C9	B9
	MCSX5_0		97	82	67	60	B9	C9
	MCSX6_0		104	89	70	67	C6	C7
	MCSX7_0		106	91	72	69	B6	D6
	MCSX8_0		35	30	-	8	L3	M3
	MADATA00_0	External bus interface data bus (Address / data multiplex bus)	2	2	2	80	C1	C1
	MADATA01_0		3	3	3	81	C2	C2
	MADATA02_0		4	4	4	82	C3	D1
	MADATA03_0		5	5	5	83	D1	D2
	MADATA04_0		6	6	6	84	D2	D3
	MADATA05_0		7	7	7	85	E1	E1
	MADATA06_0		8	8	8	86	E2	E2
	MADATA07_0		9	9	9	87	E3	E3
	MADATA08_0		10	10	10	88	F1	E4
	MADATA09_0		11	11	11	89	F2	F1
	MADATA10_0		12	12	12	90	F3	F2
	MADATA11_0		13	13	-	91	G1	F3
	MADATA12_0		14	14	-	92	G2	F4
	MADATA13_0		15	15	-	93	G3	G1
	MADATA14_0		16	16	-	94	H2	G2
	MADATA15_0		17	17	-	95	H3	G3
	MDQM0_0		External bus interface byte mask signal output pin	93	78	63	56	B11
	MDQM1_0	92		77	62	55	A12	B13
	MALE_0	External bus interface Address Latch enable output signal for multiplex	94	79	64	57	B10	A11
	MRDY_0	External bus interface external RDY input signal	116	96	76	74	B3	B3
	MCLKOUT_0	External bus interface external clock output pin	99	84	-	62	A8	A9
MNALE_0	External bus interface ALE signal to control NAND Flash output pin	18	-	-	-	-	G4	
MNCLE_0	External bus interface CLE signal to control NAND Flash output pin	19	-	-	-	-	H1	
MNREX_0	External bus interface read enable signal to control NAND Flash	21	-	-	-	-	H3	
MNWEX_0	External bus interface write enable signal to control NAND Flash	20	-	-	-	-	H2	
MOEX_0	External bus interface read enable signal for SRAM	114	94	74	72	B5	C4	
MWEX_0	External bus interface write enable signal for SRAM	113	93	73	71	C5	B5	
External Bus	MSDCLK_0	SDRAM interface SDRAM clock output pin	23	18	-	96	J1	J1
	MSDCKE_0	SDRAM interface SDRAM clock enable pin	24	19	-	97	J2	J2
	MRASX_0	SDRAM interface SDRAM row address strobe pin	25	20	-	98	J3	J3
	MCASX_0	SDRAM interface SDRAM column address strobe pin	26	21	-	99	K1	J4
	MSDWEX_0	SDRAM interface SDRAM write enable pin	34	29	-	7	M3	N3

Pin function	Pin name	Function description	Pin No					
			LQFP 120	LQFP 100	LQFP 80	QFP 100	BGA 112	BGA 144
External Interrupt	INT00_0	External interrupt request 00 input pin	2	2	2	80	C1	C1
	INT00_1		95	80	65	58	A10	B10
	INT00_2		108	-	-	-	-	C6
	INT01_0	External interrupt request 01 input pin	3	3	3	81	C2	C2
	INT01_1		101	86	-	64	C8	C8
	INT01_2		85	-	-	-	-	E10
	INT02_0	External interrupt request 02 input pin	6	6	6	84	D2	D3
	INT02_1		62	52	41	30	L13	L12
	INT02_2		82	-	-	-	-	E13
	INT03_0	External interrupt request 03 input pin	113	93	73	71	C5	B5
	INT03_1		65	55	44	33	K12	J12
	INT03_2		54	-	-	-	-	M10
	INT04_0	External interrupt request 04 input pin	17	12	12	90	F3	G3
	INT04_1		114	94	74	72	B5	C4
	INT04_2		10	-	-	-	-	E4
	INT05_0	External interrupt request 05 input pin	89	74	-	52	C12	C12
	INT05_1		75	65	54	43	G12	G12
	INT05_2		21	16	-	94	H2	H3
	INT06_1	External interrupt request 06 input pin	88	73	59	51	C13	D11
	INT06_2		22	17	-	95	H3	H4
	INT07_1	External interrupt request 07 input pin	11	-	-	-	-	F1
	INT07_2		7	7	7	85	E1	E1
	INT08_1	External interrupt request 08 input pin	19	14	-	92	G2	H1
	INT08_2		8	8	8	86	E2	E2
	INT09_1	External interrupt request 09 input pin	20	15	-	93	G3	H2
	INT09_2		15	10	10	88	F1	G1
	INT10_1	External interrupt request 10 input pin	16	11	11	89	F2	G2
	INT10_2		112	-	-	-	-	C5
	INT11_1	External interrupt request 11 input pin	50	45	35	23	L9	L8
	INT11_2		110	-	-	-	-	A6
	INT12_1	External interrupt request 12 input pin	32	27	-	5	N2	N2
	INT12_2		96	81	66	59	A9	D9
	INT13_1	External interrupt request 13 input pin	33	28	-	6	N3	L2
	INT13_2		49	44	34	22	M9	M8
	INT14_1	External interrupt request 14 input pin	68	58	47	36	J11	H12
	INT14_2		53	-	-	-	-	K9
	INT15_1	External interrupt request 15 input pin	52	-	-	-	-	L9
	INT15_2		14	9	9	87	E3	F4
	NMIX	Non-Maskable Interrupt input pin	116	96	76	74	B3	B3

Pin function	Pin name	Function description	Pin No					
			LQFP 120	LQFP 100	LQFP 80	QFP 100	BGA 112	BGA 144
GPIO	P00	General-purpose I/O port 0	106	91	72	69	B6	D6
	P01		105	90	71	68	A6	B7
	P02		104	89	70	67	C6	C7
	P03		103	88	69	66	B7	D7
	P04		102	87	68	65	C7	B8
	P05		101	86	-	64	C8	C8
	P06		100	85	-	63	B8	D8
	P07		99	84	-	62	A8	A9
	P08		98	83	-	61	C9	B9
	P09		97	82	67	60	B9	C9
	P0A		96	81	66	59	A9	D9
	P0B		95	80	65	58	A10	B10
	P0C		94	79	64	57	B10	A11
	P0D		93	78	63	56	B11	C10
	P0E		92	77	62	55	A12	B13
	P10	62	52	41	30	L13	L12	
	P11	63	53	42	31	L12	K12	
	P12	64	54	43	32	K13	K11	
	P13	65	55	44	33	K12	J12	
	P14	66	56	45	34	J13	J11	
	P15	67	57	46	35	J12	J10	
	P16	68	58	47	36	J11	H12	
	P17	69	59	48	37	H12	H11	
	P18	74	64	53	42	H11	H10	
	P19	75	65	54	43	G12	G12	
	P1A	76	66	55	44	G11	G11	
	P1B	77	67	56	45	F12	G10	
	P1C	78	68	-	46	F11	F13	
	P1D	79	69	-	47	E12	F12	
	P1E	80	70	-	48	E11	F11	
P1F	81	-	-	-	-	F10		
P20	89	74	-	52	C12	C12		
P21	88	73	59	51	C13	D11		
P22	87	72	58	50	D12	D12		
P23	86	71	57	49	D13	D13		
P24	85	-	-	-	-	E10		
P25	84	-	-	-	-	E11		
P26	83	-	-	-	-	E12		
P27	82	-	-	-	-	E13		
		General-purpose I/O port 1						
		General-purpose I/O port 2						

Pin function	Pin name	Function description	Pin No						
			LQFP 120	LQFP 100	LQFP 80	QFP 100	BGA 112	BGA 144	
GPIO	P30	General-purpose I/O port 3	14	9	9	87	E3	F4	
	P31		15	10	10	88	F1	G1	
	P32		16	11	11	89	F2	G2	
	P33		17	12	12	90	F3	G3	
	P34		18	13	-	91	G1	G4	
	P35		19	14	-	92	G2	H1	
	P36		20	15	-	93	G3	H2	
	P37		21	16	-	94	H2	H3	
	P38		22	17	-	95	H3	H4	
	P39		23	18	13	96	J1	J1	
	P3A		24	19	14	97	J2	J2	
	P3B		25	20	15	98	J3	J3	
	P3C		26	21	16	99	K1	J4	
	P3D		27	22	17	100	K2	K2	
	P3E		28	23	18	1	L1	K3	
	P3F		29	24	19	2	L2	L1	
	P40		32	27	-	5	N2	N2	
	P41	33	28	-	6	N3	L2		
	P42	34	29	-	7	M3	N3		
	P43	35	30	-	8	L3	M3		
	P44	36	31	21	9	M4	L4		
	P45	37	32	22	10	L5	K5		
	P46	39	34	24	12	N5	N5		
	P47	40	35	25	13	N6	M5		
	P48	41	36	26	14	L6	L6		
	P49	42	37	27	15	M7	K6		
	P4B	47	42	32	20	L7	L7		
	P4C	48	43	33	21	L8	K7		
	P4D	49	44	34	22	M9	M8		
	P4E	50	45	35	23	L9	L8		
	P50	2	General-purpose I/O port 5	2	2	2	80	C1	C1
	P51	3		3	3	81	C2	C2	
	P52	4		4	4	82	C3	D1	
	P53	5		5	5	83	D1	D2	
	P54	6		6	6	84	D2	D3	
	P55	7		7	7	85	E1	E1	
	P56	8		8	8	86	E2	E2	
	P57	9		-	-	-	-	E3	
	P58	10		-	-	-	-	E4	
	P59	11		-	-	-	-	F1	
	P5A	12		-	-	-	-	F2	
	P5B	13		-	-	-	-	F3	

Pin function	Pin name	Function description	Pin No					
			LQFP 120	LQFP 100	LQFP 80	QFP 100	BGA 112	BGA 144
GPIO	P60	General-purpose I/O port 6	116	96	76	74	B3	B3
	P61		115	95	75	73	B4	B4
	P62		114	94	74	72	B5	C4
	P63		113	93	73	71	C5	B5
	P64		112	-	-	-	-	C5
	P65		111	-	-	-	-	D5
	P66		110	-	-	-	-	A6
	P67		109	-	-	-	-	B6
	P68		108	-	-	-	-	C6
	P70	General-purpose I/O port 7	51	-	-	-	-	K8
	P71		52	-	-	-	-	L9
	P72		53	-	-	-	-	K9
	P73		54	-	-	-	-	M10
	P74		55	-	-	-	-	L10
	P80	General-purpose I/O port 8	118	98	78	76	A3	A3
	P81		119	99	79	77	A2	A2
	PE0	General-purpose I/O port E	56	46	36	24	M10	N10
	PE2		58	48	38	26	N11	N11
PE3	59		49	39	27	N12	N12	
Multi- function Serial 0	SIN0_0	Multi-function serial interface ch.0 input pin	88	73	59	51	C13	D11
	SIN0_1		65	55	44	33	K12	J12
	SOT0_0 (SDA0_0)	Multi-function serial interface ch.0 output pin. This pin operates as SOT0 when it is used in a UART/CSIO/LIN (operation modes 0 to 3) and as SDA0 when it is used in an I <sup>2</sup> C (operation mode 4).	87	72	58	50	D12	D12
	SOT0_1 (SDA0_1)		66	56	45	34	J13	J11
	SCK0_0 (SCL0_0)		86	71	57	49	D13	D13
SCK0_1 (SCL0_1)	67	57	46	35	J12	J10		
Multi- function Serial 1	SIN1_0	Multi-function serial interface ch.1 input pin	96	81	66	59	A9	D9
	SIN1_1		62	52	41	30	L13	L12
	SOT1_0 (SDA1_0)	Multi-function serial interface ch.1 output pin. This pin operates as SOT1 when it is used in a UART/CSIO/LIN (operation modes 0 to 3) and as SDA1 when it is used in an I <sup>2</sup> C (operation mode 4).	97	82	67	60	B9	C9
	SOT1_1 (SDA1_1)		63	53	42	31	L12	K12
	SCK1_0 (SCL1_0)		98	83	-	61	C9	B9
SCK1_1 (SCL1_1)	64	54	43	32	K13	K11		

Pin function	Pin name	Function description	Pin No					
			LQFP 120	LQFP 100	LQFP 80	QFP 100	BGA 112	BGA 144
Multi- function Serial 2	SIN2_0	Multi-function serial interface ch.2 input pin	53	-	-	-	-	K9
	SIN2_1		85	-	-	-	-	E10
	SIN2_2		68	58	47	36	J11	H12
	SOT2_0 (SDA2_0)	Multi-function serial interface ch.2 output pin. This pin operates as SOT2 when it is used in a UART/CSIO/LIN (operation modes 0 to 3) and as SDA2 when it is used in an I <sup>2</sup> C (operation mode 4).	54	-	-	-	-	M10
	SOT2_1 (SDA2_1)		84	-	-	-	-	E11
	SOT2_2 (SDA2_2)		69	59	48	37	H12	H11
	SCK2_0 (SCL2_0)	Multi-function serial interface ch.2 clock I/O pin. This pin operates as SCK2 when it is used in a CSIO (operation modes 2) and as SCL2 when it is used in an I <sup>2</sup> C (operation mode 4).	55	-	-	-	-	L10
	SCK2_1 (SCL2_1)		83	-	-	-	-	E12
	SCK2_2 (SCL2_2)		74	64	53	42	H11	H10
Multi- function Serial 3	SIN3_0	Multi-function serial interface ch.3 input pin	110	-	-	-	-	A6
	SIN3_1		15	10	10	88	F1	G1
	SOT3_0 (SDA3_0)	Multi-function serial interface ch.3 output pin. This pin operates as SOT3 when it is used in a UART/CSIO/LIN (operation modes 0 to 3) and as SDA3 when it is used in an I <sup>2</sup> C (operation mode 4).	109	-	-	-	-	B6
	SOT3_1 (SDA3_1)		16	11	11	89	F2	G2
	SCK3_0 (SCL3_0)		108	-	-	-	-	C6
SCK3_1 (SCL3_1)	17	12	12	90	F3	G3		
Multi- function Serial 4	SIN4_0	Multi-function serial interface ch.4 input pin	6	6	6	84	D2	D3
	SIN4_1		75	65	54	43	G12	G12
	SIN4_2		10	-	-	-	-	E4
	SOT4_0 (SDA4_0)	Multi-function serial interface ch.4 output pin. This pin operates as SOT4 when it is used in a UART/CSIO/LIN (operation modes 0 to 3) and as SDA4 when it is used in an I <sup>2</sup> C (operation mode 4).	5	5	5	83	D1	D2
	SOT4_1 (SDA4_1)		76	66	55	44	G11	G11
	SOT4_2 (SDA4_2)		11	-	-	-	-	F1
	SCK4_0 (SCL4_0)	Multi-function serial interface ch.4 clock I/O pin. This pin operates as SCK4 when it is used in a CSIO (operation modes 2) and as SCL4 when it is used in an I <sup>2</sup> C (operation mode 4).	4	4	4	82	C3	D1
	SCK4_1 (SCL4_1)		77	67	56	45	F12	G10
	SCK4_2 (SCL4_2)		12	-	-	-	-	F2
	CTS4_0	Multi-function serial interface ch.4 CTS input pin	2	2	2	80	C1	C1
	CTS4_1		78	68	-	46	F11	F13
	CTS4_2		13	-	-	-	-	F3
	RTS4_0	Multi-function serial interface ch.4 RTS output pin	3	3	3	81	C2	C2
	RTS4_1		79	69	-	47	E12	F12
RTS4_2	14		9	9	87	E3	F4	

Pin function	Pin name	Function description	Pin No					
			LQFP 120	LQFP 100	LQFP 80	QFP 100	BGA 112	BGA 144
Multi- function Serial 5	SIN5_0	Multi-function serial interface ch.5 input pin	114	94	74	72	B5	C4
	SIN5_1		113	-	-	-	-	B5
	SIN5_2		20	15	-	93	G3	H2
	SOT5_0 (SDA5_0)	Multi-function serial interface ch.5 output pin. This pin operates as SOT5 when it is used in a UART/CSIO/LIN (operation modes 0 to 3) and as SDA5 when it is used in an I <sup>2</sup> C (operation mode 4).	115	95	75	73	B4	B4
	SOT5_1 (SDA5_1)		112	-	-	-	-	C5
	SOT5_2 (SDA5_2)		21	16	-	94	H2	H3
	SCK5_0 (SCL5_0)	Multi-function serial interface ch.5 clock I/O pin. This pin operates as SCK5 when it is used in a CSIO (operation modes 2) and as SCL5 when it is used in an I <sup>2</sup> C (operation mode 4).	116	96	76	74	B3	B3
	SCK5_1 (SCL5_1)		111	-	-	-	-	D5
	SCK5_2 (SCL5_2)		22	17	-	95	H3	H4
Multi- function Serial 6	SIN6_0	Multi-function serial interface ch.6 input pin	7	7	7	85	E1	E1
	SIN6_1		95	80	65	58	A10	B10
	SOT6_0 (SDA6_0)	Multi-function serial interface ch.6 output pin. This pin operates as SOT6 when it is used in a UART/CSIO/LIN (operation modes 0 to 3) and as SDA6 when it is used in an I <sup>2</sup> C (operation mode 4).	8	8	8	86	E2	E2
	SOT6_1 (SDA6_1)		94	79	64	57	B10	A11
	SCK6_0 (SCL6_0)	Multi-function serial interface ch.6 clock I/O pin. This pin operates as SCK6 when it is used in a CSIO (operation modes 2) and as SCL6 when it is used in an I <sup>2</sup> C (operation mode 4).	9	-	-	-	-	E3
	SCK6_1 (SCL6_1)		93	78	63	56	B11	C10
SCS6_1	Multi-function serial interface ch.6 serial chip select pin	92	77	62	55	A12	B13	
Multi- function Serial 7	SIN7_0	Multi-function serial interface ch.7 input pin	101	86	-	64	C8	C8
	SIN7_1		50	45	35	23	L9	L8
	SOT7_0 (SDA7_0)	Multi-function serial interface ch.7 output pin. This pin operates as SOT7 when it is used in a UART/CSIO/LIN (operation modes 0 to 3) and as SDA7 when it is used in an I <sup>2</sup> C (operation mode 4).	100	85	-	63	B8	D8
	SOT7_1 (SDA7_1)		49	44	34	22	M9	M8
	SCK7_0 (SCL7_0)	Multi-function serial interface ch.7 clock I/O pin. This pin operates as SCK7 when it is used in a CSIO (operation modes 2) and as SCL7 when it is used in an I <sup>2</sup> C (operation mode 4).	99	84	-	62	A8	A9
	SCK7_1 (SCL7_1)		48	43	33	21	L8	K7
	SCS7_1	Multi-function serial interface ch.7 serial chip select pin	47	42	32	20	L7	L7

Pin function	Pin name	Function description	Pin No						
			LQFP 120	LQFP 100	LQFP 80	QFP 100	BGA 112	BGA 144	
Multi-function Timer 0	DTTI0X_0	Input signal controlling wave form generator outputs RTO00 to RTO05 of Multi-function timer 0.	23	18	13	96	J1	J1	
	DTTI0X_1		79	69	-	47	E12	F12	
	FRCK0_0	16-bit free-run timer ch.0 external clock input pin	18	13	-	91	G1	G4	
	FRCK0_1		80	70	-	48	E11	F11	
	FRCK0_2		62	52	41	30	L13	L12	
	IC00_0	16-bit input capture ch.0 input pin of Multi-function timer 0. Icxx describes channel number.	22	17	-	95	H3	H4	
	IC00_1		75	65	54	43	G12	G12	
	IC00_2		63	53	42	31	L12	K12	
	IC01_0		21	16	-	94	H2	H3	
	IC01_1		76	66	55	44	G11	G11	
	IC01_2		64	54	43	32	K13	K11	
	IC02_0		20	15	-	93	G3	H2	
	IC02_1		77	67	56	45	F12	G10	
	IC02_2		65	55	44	33	K12	J12	
	IC03_0		19	14	-	92	G2	H1	
	IC03_1		78	68	-	46	F11	F13	
	IC03_2		66	56	45	34	J13	J11	
	RTO00_0 (PPG00_0)		Wave form generator output pin of Multi-function timer 0.	24	19	14	97	J2	J2
	RTO00_1 (PPG00_1)		This pin operates as PPG00 when it is used in PPG0 output modes.	86	71	57	49	D13	D13
	RTO01_0 (PPG00_0)		Wave form generator output pin of Multi-function timer 0.	25	20	15	98	J3	J3
	RTO01_1 (PPG00_1)	This pin operates as PPG00 when it is used in PPG0 output modes.	85	-	-	-	-	E10	
	RTO02_0 (PPG02_0)	Wave form generator output pin of Multi-function timer 0.	26	21	16	99	K1	J4	
	RTO02_1 (PPG02_1)	This pin operates as PPG02 when it is used in PPG0 output modes.	84	-	-	-	-	E11	
	RTO03_0 (PPG02_0)	Wave form generator output pin of Multi-function timer 0.	27	22	17	100	K2	K2	
	RTO03_1 (PPG02_1)	This pin operates as PPG02 when it is used in PPG0 output modes.	83	-	-	-	-	E12	
	RTO04_0 (PPG04_0)	Wave form generator output pin of Multi-function timer 0.	28	23	18	1	L1	K3	
	RTO04_1 (PPG04_1)	This pin operates as PPG04 when it is used in PPG0 output modes.	82	-	-	-	-	E13	
	RTO05_0 (PPG04_0)	Wave form generator output pin of Multi-function timer 0.	29	24	19	2	L2	L1	
RTO05_1 (PPG04_1)	This pin operates as PPG04 when it is used in PPG0 output modes.	81	-	-	-	-	F10		

Pin function	Pin name	Function description	Pin No						
			LQFP 120	LQFP 100	LQFP 80	QFP 100	BGA 112	BGA 144	
Multi-function Timer 1	DTT1X_0	Input signal controlling wave form generator outputs RTO10 to RTO15 of Multi-function timer 1.	8	8	8	86	E2	E2	
	DTT1X_1		55	-	-	-	-	L10	
	FRCK1_0	16-bit free-run timer ch.1 external clock input pin	96	81	66	59	A9	D9	
	FRCK1_1		50	45	35	23	L9	L8	
	IC10_0	16-bit input capture ch.1 input pin of Multi-function timer 1. Icxx describes channel number.	95	80	65	58	A10	B10	
	IC10_1		54	-	-	-	-	M10	
	IC11_0		94	79	64	57	B10	A11	
	IC11_1		53	-	-	-	-	K9	
	IC12_0		93	78	63	56	B11	C10	
	IC12_1		52	-	-	-	-	L9	
	IC13_0		92	77	62	55	A12	B13	
	IC13_1		51	-	-	-	-	K8	
	RTO10_0 (PPG10_0)		Wave form generator output pin of Multi-function timer 1.	2	2	2	80	C1	C1
	RTO10_1 (PPG10_1)		This pin operates as PPG10 when it is used in PPG1 output modes.	32	27	-	5	N2	N2
	RTO11_0 (PPG10_0)	Wave form generator output pin of Multi-function timer 1.	3	3	3	81	C2	C2	
	RTO11_1 (PPG10_1)	This pin operates as PPG10 when it is used in PPG1 output modes.	33	28	-	6	N3	L2	
	RTO12_0 (PPG12_0)	Wave form generator output pin of Multi-function timer 1.	4	4	4	82	C3	D1	
	RTO12_1 (PPG12_1)	This pin operates as PPG12 when it is used in PPG1 output modes.	34	29	-	7	M3	N3	
	RTO13_0 (PPG12_0)	Wave form generator output pin of Multi-function timer 1.	5	5	5	83	D1	D2	
	RTO13_1 (PPG12_1)	This pin operates as PPG12 when it is used in PPG1 output modes.	35	30	-	8	L3	M3	
RTO14_0 (PPG14_0)	Wave form generator output pin of Multi-function timer 1.	6	6	6	84	D2	D3		
RTO14_1 (PPG14_1)	This pin operates as PPG14 when it is used in PPG1 output modes.	36	31	21	9	M4	L4		
RTO15_0 (PPG14_0)	Wave form generator output pin of Multi-function timer 1.	7	7	7	85	E1	E1		
RTO15_1 (PPG14_1)	This pin operates as PPG14 when it is used in PPG1 output modes.	37	32	22	10	L5	K5		
Quadrature Position/ Revolution Counter 0	AIN0_0	QPRC ch.0 AIN input pin	24	19	14	97	J2	J2	
	AIN0_1		51	-	-	-	-	K8	
	AIN0_2	2	2	2	80	C1	C1		
	BIN0_0	QPRC ch.0 BIN input pin	25	20	15	98	J3	J3	
	BIN0_1		52	-	-	-	-	L9	
	BIN0_2	3	3	3	81	C2	C2		
	ZIN0_0	QPRC ch.0 ZIN input pin	26	21	16	99	K1	J4	
	ZIN0_1		53	-	-	-	-	K9	
ZIN0_2	4	4	4	82	C3	D1			
Quadrature Position/ Revolution Counter 1	AIN1_0	QPRC ch.1 AIN input pin	10	-	-	-	-	E4	
	AIN1_1		89	74	-	52	C12	C12	
	AIN1_2	48	43	33	21	L8	K7		
	BIN1_0	QPRC ch.1 BIN input pin	11	-	-	-	-	F1	
	BIN1_1		88	73	-	51	C13	D11	
	BIN1_2	49	44	34	22	M9	M8		
	ZIN1_0	QPRC ch.1 ZIN input pin	12	-	-	-	-	F2	
	ZIN1_1		87	72	-	50	D12	D12	
ZIN1_2	50	45	35	23	L9	L8			

Pin function	Pin name	Function description	Pin No					
			LQFP 120	LQFP 100	LQFP 80	QFP 100	BGA 112	BGA 144
Real-time clock	RTCCO_0	0.5 seconds pulse output pin of Real-time clock	115	95	75	73	B4	B4
	RTCCO_1		64	54	43	32	K13	K11
	RTCCO_2		23	18	13	96	J1	J1
	SUBOUT_0	Sub clock output pin	115	95	75	73	B4	B4
	SUBOUT_1		64	54	43	32	K13	K11
	SUBOUT_2		23	18	13	96	J1	J1
Low-Power Consumption Mode	WKUP0	Deep standby mode return signal input pin 0	116	96	76	74	B3	B3
	WKUP1	Deep standby mode return signal input pin 1	14	9	9	87	E3	F4
	WKUP2	Deep standby mode return signal input pin 2	50	45	35	23	L9	L8
	WKUP3	Deep standby mode return signal input pin 3	69	59	48	37	H12	H11
DAC	DA0	D/A converter ch.0 analog output pin	36	31	21	9	M4	L4
	DA1	D/A converter ch.1 analog output pin	37	32	22	10	L5	K5
VBAT	VREGCTL	On-board regulator control pin	41	36	26	14	L6	L6
	VWAKEUP	The return signal input pin from a hibernation state	42	37	27	15	M7	K6
SD I/F	S_CLK_0	SD memory card interface SD memory card clock output pin	92	77	62	55	A12	B13
	S_CMD_0	SD memory card interface SD memory card command output	93	78	63	56	B11	C10
	S_DATA1_0	SD memory card interface SD memory card data bus	94	79	64	57	B10	A11
	S_DATA0_0		95	80	65	58	A10	B10
	S_DATA3_0		96	81	66	59	A9	D9
	S_DATA2_0		97	82	67	60	B9	C9
	S_CD_0	SD memory card interface SD memory card detection pin	113	93	73	71	C5	B5
S_WP_0	SD memory card interface SD memory card write protection	114	94	74	72	B5	C4	
Reset	INITX	External Reset Input pin. A reset is valid when INITX = "L".	38	33	23	11	M6	N4
Mode	MD1	Mode 1 pin. During serial programming to Flash memory, MD1 = "L" must be input.	56	46	36	24	M10	N10
	MD0	Mode 0 pin. During normal operation, MD0 = "L" must be input. During serial programming to Flash memory, MD0 = "H" must be input.	57	47	37	25	M11	M11
Power	VCC	Power supply Pin	1	1	1	79	B1	B1
			31	26	-	4	M1	M1
			46	41	31	19	M8	M9
			61	51	-	29	M13	M13
			91	76	61	54	B13	A12
			117	97	77	75	A4	A4

Pin function	Pin name	Function description	Pin No								
			LQFP 120	LQFP 100	LQFP 80	QFP 100	BGA 112	BGA 144			
GND	VSS	GND Pin	107	92	-	70	A5	A7			
			30	25	20	3	N1	N1			
			45	40	30	18	N10	N9			
			60	50	40	28	N13	N13			
			90	75	60	53	A13	A13			
			120	100	80	78	A1	A1			
			-	-	-	-	A7	A5			
			-	-	-	-	B2	A8			
			-	-	-	-	B12	A10			
			-	-	-	-	C11	B2			
			-	-	-	-	H1	B11			
			-	-	-	-	N4	B12			
			-	-	-	-	M5	C3			
			-	-	-	-	N7	C11			
			-	-	-	-	L11	C13			
			-	-	-	-	A11	D4			
			-	-	-	-	M12	D10			
			-	-	-	-	M2	K1			
			GND	VSS	GND Pin	-	-	-	-	-	K4
						-	-	-	-	-	K10
-	-	-				-	-	L3			
-	-	-				-	-	L5			
-	-	-				-	-	L11			
-	-	-				-	-	L13			
GND	VSS	GND Pin	-	-	-	-	-	M2			
			-	-	-	-	-	M4			
			-	-	-	-	-	M6			
			-	-	-	-	-	M7			
Clock	X0	Main clock (oscillation) input pin	58	48	38	26	N11	N11			
	X1	Main clock (oscillation) I/O pin	59	49	39	27	N12	N12			
	X0A	Sub clock (oscillation) input pin	39	34	24	12	N5	N5			
	X1A	Sub clock (oscillation) I/O pin	40	35	25	13	N6	M5			
	CROUT_0	Built-in high-speed CR-osc clock output port	87	72	58	50	D12	D12			
	CROUT_1		113	93	73	71	C5	B5			
ADC Power	AVCC	A/D converter and D/A converter analog power supply pin	70	60	49	38	H13	K13			
	AVRL	A/D converter analog reference voltage input pin	72	62	51	40	F13	H13			
	AVRH	A/D converter analog reference voltage input pin	73	63	52	41	E13	G13			
VBAT Power	VBAT	VBAT power supply pin. Backup power supply (battery etc.) and system power supply.	43	38	28	16	N8	N7			
ADC GND	AVSS	A/D converter and D/A converter GND pin	71	61	50	39	G13	J13			
C pin	C	Power supply stabilization capacity pin	44	39	29	17	N9	N8			

**Note:**

- While this device contains a Test Access Port (TAP) based on the IEEE 1149.1-2001 JTAG standard, it is not fully compliant to all requirements of that standard. This device may contain a 32-bit device ID that is the same as the 32-bit device ID in other devices with different functionality. The TAP pins may also be configurable for purposes other than access to the TAP controller.

5. I/O Circuit Type

Type	Circuit	Remarks
A		<p>It is possible to select the main oscillation / GPIO function</p> <p>When the main oscillation is selected.</p> <ul style="list-style-type: none"> <li>• Oscillation feedback resistor : Approximately 1 MΩ</li> <li>• With Standby mode control</li> </ul> <p>When the GPIO is selected.</p> <ul style="list-style-type: none"> <li>• CMOS level output.</li> <li>• CMOS level hysteresis input</li> <li>• With pull-up resistor control</li> <li>• With standby mode control</li> <li>• Pull-up resistor : Approximately 50 Kω</li> <li>• <math>I_{OH} = -4 \text{ Ma}</math>, <math>I_{OL} = 4 \text{ Ma}</math></li> </ul>
B		<ul style="list-style-type: none"> <li>• CMOS level hysteresis input</li> <li>• Pull-up resistor : Approximately 50 Kω</li> </ul>

Type	Circuit	Remarks
C		<ul style="list-style-type: none"> <li>• Open drain output</li> <li>• CMOS level hysteresis input</li> </ul>
E		<ul style="list-style-type: none"> <li>• CMOS level output</li> <li>• CMOS level hysteresis input</li> <li>• With pull-up resistor control</li> <li>• With standby mode control</li> <li>• Pull-up resistor : Approximately 50 K<math>\omega</math></li> <li>• I<sub>OH</sub> = -4 Ma, I<sub>OL</sub> = 4 Ma</li> </ul>
F		<ul style="list-style-type: none"> <li>• CMOS level output</li> <li>• CMOS level hysteresis input</li> <li>• With input control</li> <li>• Analog input</li> <li>• With pull-up resistor control</li> <li>• With standby mode control</li> <li>• Pull-up resistor : Approximately 50 K<math>\omega</math></li> <li>• I<sub>OH</sub> = -4 Ma, I<sub>OL</sub> = 4 Ma</li> </ul>

Type	Circuit	Remarks
G		<ul style="list-style-type: none"> <li>• CMOS level output</li> <li>• CMOS level hysteresis input</li> <li>• With pull-up resistor control</li> <li>• With standby mode control</li> <li>• Pull-up resistor : Approximately 50 Kw</li> <li>• <math>I_{OH} = -12 \text{ Ma}</math>, <math>I_{OL} = 12 \text{ Ma}</math></li> </ul>
H		<ul style="list-style-type: none"> <li>• CMOS level output</li> <li>• CMOS level hysteresis input</li> <li>• With standby mode control</li> <li>• <math>I_{OH} = -20.5 \text{ Ma}</math>, <math>I_{OL} = 18.5 \text{ Ma}</math></li> </ul>

Type	Circuit	Remarks
I		<ul style="list-style-type: none"> <li>• CMOS level output</li> <li>• CMOS level hysteresis input</li> <li>• 5V tolerant</li> <li>• With standby mode control</li> <li>• Pull-up resistor : Approximately 50 K<math>\omega</math></li> <li>• I<sub>OH</sub> = -4 Ma, I<sub>OL</sub> = 4 Ma</li> <li>• Available to control of PZR registers.</li> </ul>
J		<p>CMOS level hysteresis input</p>
L		<ul style="list-style-type: none"> <li>• CMOS level output</li> <li>• CMOS level hysteresis input</li> <li>• With pull-up resistor control</li> <li>• With standby mode control</li> <li>• Pull-up resistor : Approximately 50 K<math>\omega</math></li> <li>• I<sub>OH</sub> = -8 Ma, I<sub>OL</sub> = 8 Ma</li> </ul>

Type	Circuit	Remarks
M	<p>The diagram for Type M shows a multiplexer with two digital outputs: a P-channel MOSFET (P-ch) and an N-channel MOSFET (N-ch). A pull-up resistor is connected to the P-ch output. The circuit also includes a pull-up resistor control input, a digital input with a pull-up resistor R, a standby mode control input, and an analog input with an input control input.</p>	<ul style="list-style-type: none"> <li>• CMOS level output</li> <li>• CMOS level hysteresis input</li> <li>• With input control</li> <li>• Analog input</li> <li>• With pull-up resistor control</li> <li>• With standby mode control</li> <li>• Pull-up resistor : Approximately 50 K<math>\omega</math></li> <li>• <math>I_{OH} = -8 \text{ Ma}</math>, <math>I_{OL} = 8 \text{ Ma}</math></li> </ul>
N	<p>The diagram for Type N shows a multiplexer with two digital outputs: a P-channel MOSFET (P-ch) and an N-channel MOSFET (N-ch). A pull-up resistor is connected to the P-ch output. The circuit also includes a pull-up resistor control input, a fast mode control input, a digital input with a pull-up resistor R, and a standby mode control input.</p>	<ul style="list-style-type: none"> <li>• CMOS level output</li> <li>• CMOS level hysteresis input</li> <li>• 5V tolerant</li> <li>• Pull-up resistor control</li> <li>• Standby mode control</li> <li>• Pull-up resistor: approximately 50 K<math>\omega</math></li> <li>• <math>I_{OH} = -4 \text{ Ma}</math>, <math>I_{OL} = 4 \text{ Ma}</math> (GPIO)</li> <li>• <math>I_{OL} = 20 \text{ Ma}</math> (Fast mode Plus)</li> <li>• Available to control of PZR register (pseudo-open drain control)</li> <li>• For PZR registers, refer to GPIO in the FM4 Family Peripheral Manual Main Part (002-04856).</li> <li>• When this pin is used as an I<sup>2</sup>C pin, the digital output P-ch transistor is always off.</li> </ul>

Type	Circuit	Remarks
O		<ul style="list-style-type: none"> <li>• CMOS level output</li> <li>• CMOS level hysteresis input</li> <li>• 5 V tolerant</li> <li>• Pull-up resistor control</li> <li>• Pull-up resistor: approximately 50 K<math>\omega</math></li> <li>• I<sub>OH</sub> = -4 Ma, I<sub>OL</sub> = 4 Ma</li> <li>• Available to control of PZR register (pseudo-open drain control)</li> <li>• For PZR registers, refer to GPIO in the “FM4 Family Peripheral Manual Main Part (002-04856)”.</li> <li>• For I/O setting, refer to VBAT Domain in the FM4 Family Peripheral Manual Main Part (002-04856).</li> </ul>
P		<ul style="list-style-type: none"> <li>• CMOS level output</li> <li>• CMOS level hysteresis input</li> <li>• With pull-up resistor control</li> <li>• With standby mode control</li> <li>• Pull-up resistor : Approximately 50 K<math>\omega</math></li> <li>• I<sub>OH</sub> = -4 Ma, I<sub>OL</sub> = 4 Ma</li> <li>• For I/O setting, refer to VBAT Domain in the Peripheral Manual</li> </ul>

Type	Circuit	Remarks
Q	<p>The diagram for Type Q shows a multiplexer (X1A) with several control and output options. A pull-up resistor is connected to the input of the multiplexer. The output can be configured as a digital output (P-ch or N-ch), a digital input with a pull-up resistor R, a standby mode control signal, an oscillator (OSC) signal, or a clock input with a pull-up resistor RX.</p>	<p>It is possible to select the sub oscillation / GPIO function</p> <p>When the sub oscillation is selected.</p> <ul style="list-style-type: none"> <li>Oscillation feedback resistor : Approximately 10 MΩ</li> <li>With Standby mode control</li> </ul> <p>When the GPIO is selected.</p> <ul style="list-style-type: none"> <li>CMOS level output.</li> <li>CMOS level hysteresis input</li> <li>With pull-up resistor control</li> <li>With standby mode control</li> <li>Pull-up resistor : Approximately 50 KΩ</li> <li><math>I_{OH} = -4 \text{ Ma}</math>, <math>I_{OL} = 4 \text{ Ma}</math></li> <li>For I/O setting, refer to VBAT Domain in the Peripheral Manual</li> </ul>
R	<p>The diagram for Type R shows a multiplexer with a pull-up resistor on the input. The output can be configured as a digital output (P-ch or N-ch), a digital input with a pull-up resistor R, a standby mode control signal, or an analog output.</p>	<ul style="list-style-type: none"> <li>CMOS level output</li> <li>CMOS level hysteresis input</li> <li>Analog output</li> <li>With pull-up resistor control</li> <li>With standby mode control</li> <li>Pull-up resistor : Approximately 50 KΩ</li> <li><math>I_{OH} = -12 \text{ Ma}</math>, <math>I_{OL} = 12 \text{ Ma}</math> (4.5 V to 5.5 V)</li> <li><math>I_{OH} = -8 \text{ Ma}</math>, <math>I_{OL} = 8 \text{ Ma}</math> (2.7 V to 4.5 V)</li> </ul>

## 6. Handling Precautions

Any semiconductor devices have inherently a certain rate of failure. The possibility of failure is greatly affected by the conditions in which they are used (circuit conditions, environmental conditions, etc.). This page describes precautions that must be observed to minimize the chance of failure and to obtain higher reliability from your Cypress semiconductor devices.

### 6.1 Precautions for Product Design

This section describes precautions when designing electronic equipment using semiconductor devices.

#### Absolute Maximum Ratings

Semiconductor devices can be permanently damaged by application of stress (voltage, current, temperature, etc.) in excess of certain established limits, called absolute maximum ratings. Do not exceed these ratings.

#### Recommended Operating Conditions

Recommended operating conditions are normal operating ranges for the semiconductor device. All the device's electrical characteristics are warranted when operated within these ranges.

Always use semiconductor devices within the recommended operating conditions. Operation outside these ranges may adversely affect reliability and could result in device failure.

No warranty is made with respect to uses, operating conditions, or combinations not represented on the data sheet. Users considering application outside the listed conditions are advised to contact their sales representative beforehand.

#### Processing and Protection of Pins

These precautions must be followed when handling the pins which connect semiconductor devices to power supply and input/output functions.

##### 1. Preventing Over-Voltage and Over-Current Conditions

Exposure to voltage or current levels in excess of maximum ratings at any pin is likely to cause deterioration within the device, and in extreme cases leads to permanent damage of the device. Try to prevent such overvoltage or over-current conditions at the design stage.

##### 2. Protection of Output Pins

Shorting of output pins to supply pins or other output pins, or connection to large capacitance can cause large current flows. Such conditions if present for extended periods of time can damage the device. Therefore, avoid this type of connection.

##### 3. Handling of Unused Input Pins

Unconnected input pins with very high impedance levels can adversely affect stability of operation. Such pins should be connected through an appropriate resistance to a power supply pin or ground pin.

#### Latch-up

Semiconductor devices are constructed by the formation of P-type and N-type areas on a substrate. When subjected to abnormally high voltages, internal parasitic PNP junctions (called thyristor structures) may be formed, causing large current levels in excess of several hundred Ma to flow continuously at the power supply pin. This condition is called latch-up.

**CAUTION:** The occurrence of latch-up not only causes loss of reliability in the semiconductor device, but can cause injury or damage from high heat, smoke or flame. To prevent this from happening, do the following:

1. Be sure that voltages applied to pins do not exceed the absolute maximum ratings. This should include attention to abnormal noise, surge levels, etc.
2. Be sure that abnormal current flows do not occur during the power-on sequence.

#### Observance of Safety Regulations and Standards

Most countries in the world have established standards and regulations regarding safety, protection from electromagnetic interference, etc. Customers are requested to observe applicable regulations and standards in the design of products.

#### Fail-Safe Design

Any semiconductor devices have inherently a certain rate of failure. You must protect against injury, damage or loss from such failures by incorporating safety design measures into your facility and equipment such as redundancy, fire protection, and prevention of over-current levels and other abnormal operating conditions.

## Precautions Related to Usage of Devices

Cypress semiconductor devices are intended for use in standard applications (computers, office automation and other office equipment, industrial, communications, and measurement equipment, personal or household devices, etc.).

CAUTION: Customers considering the use of our products in special applications where failure or abnormal operation may directly affect human lives or cause physical injury or property damage, or where extremely high levels of reliability are demanded (such as aerospace systems, atomic energy controls, sea floor repeaters, vehicle operating controls, medical devices for life support, etc.) are requested to consult with sales representatives before such use. The company will not be responsible for damages arising from such use without prior approval.

## 6.2 Precautions for Package Mounting

Package mounting may be either lead insertion type or surface mount type. In either case, for heat resistance during soldering, you should only mount under Cypress' recommended conditions. For detailed information about mount conditions, contact your sales representative.

### Lead Insertion Type

Mounting of lead insertion type packages onto printed circuit boards may be done by two methods: direct soldering on the board, or mounting by using a socket.

Direct mounting onto boards normally involves processes for inserting leads into through-holes on the board and using the flow soldering (wave soldering) method of applying liquid solder. In this case, the soldering process usually causes leads to be subjected to thermal stress in excess of the absolute ratings for storage temperature. Mounting processes should conform to Cypress recommended mounting conditions.

If socket mounting is used, differences in surface treatment of the socket contacts and IC lead surfaces can lead to contact deterioration after long periods. For this reason it is recommended that the surface treatment of socket contacts and IC leads be verified before mounting.

### Surface Mount Type

Surface mount packaging has longer and thinner leads than lead-insertion packaging, and therefore leads are more easily deformed or bent. The use of packages with higher pin counts and narrower pin pitch results in increased susceptibility to open connections caused by deformed pins, or shorting due to solder bridges.

You must use appropriate mounting techniques. Cypress recommends the solder reflow method, and has established a ranking of mounting conditions for each product. Users are advised to mount packages in accordance with Cypress ranking of recommended conditions.

### Lead-Free Packaging

CAUTION: When ball grid array (BGA) packages with Sn-Ag-Cu balls are mounted using Sn-Pb eutectic soldering, junction strength may be reduced under some conditions of use.

## Storage of Semiconductor Devices

Because plastic chip packages are formed from plastic resins, exposure to natural environmental conditions will cause absorption of moisture. During mounting, the application of heat to a package that has absorbed moisture can cause surfaces to peel, reducing moisture resistance and causing packages to crack. To prevent, do the following:

1. Avoid exposure to rapid temperature changes, which cause moisture to condense inside the product. Store products in locations where temperature changes are slight.
2. Use dry boxes for product storage. Products should be stored below 70% relative humidity, and at temperatures between 5°C and 30°C.  
When you open Dry Package that recommends humidity 40% to 70% relative humidity.
3. When necessary, Cypress packages semiconductor devices in highly moisture-resistant aluminum laminate bags, with a silica gel desiccant. Devices should be sealed in their aluminum laminate bags for storage.
4. Avoid storing packages where they are exposed to corrosive gases or high levels of dust.

## Baking

Packages that have absorbed moisture may be de-moisturized by baking (heat drying). Follow the Cypress recommended conditions for baking.

Condition: 125°C/24 h

### Static Electricity

Because semiconductor devices are particularly susceptible to damage by static electricity, you must take the following precautions:

1. Maintain relative humidity in the working environment between 40% and 70%. Use of an apparatus for ion generation may be needed to remove electricity.
2. Electrically ground all conveyors, solder vessels, soldering irons and peripheral equipment.
3. Eliminate static body electricity by the use of rings or bracelets connected to ground through high resistance (on the level of 1 MΩ).  
Wearing of conductive clothing and shoes, use of conductive floor mats and other measures to minimize shock loads is recommended.
4. Ground all fixtures and instruments, or protect with anti-static measures.
5. Avoid the use of Styrofoam or other highly static-prone materials for storage of completed board assemblies.

### 6.3 Precautions for Use Environment

Reliability of semiconductor devices depends on ambient temperature and other conditions as described above.

For reliable performance, do the following:

1. Humidity  
Prolonged use in high humidity can lead to leakage in devices as well as printed circuit boards. If high humidity levels are anticipated, consider anti-humidity processing.
2. Discharge of Static Electricity  
When high-voltage charges exist close to semiconductor devices, discharges can cause abnormal operation. In such cases, use anti-static measures or processing to prevent discharges.
3. Corrosive Gases, Dust, or Oil  
Exposure to corrosive gases or contact with dust or oil may lead to chemical reactions that will adversely affect the device. If you use devices in such conditions, consider ways to prevent such exposure or to protect the devices.
4. Radiation, Including Cosmic Radiation  
Most devices are not designed for environments involving exposure to radiation or cosmic radiation. Users should provide shielding as appropriate.
5. Smoke, Flame  
**CAUTION:** Plastic molded devices are flammable, and therefore should not be used near combustible substances. If devices begin to smoke or burn, there is danger of the release of toxic gases.

Customers considering the use of Cypress products in other special environmental conditions should consult with sales representatives.

## 7. Handling Devices

### Power supply pins

In products with multiple VCC and VSS pins, respective pins at the same potential are interconnected within the device in order to prevent malfunctions such as latch-up. However, all of these pins should be connected externally to the power supply or ground lines in order to reduce electromagnetic emission levels, to prevent abnormal operation of strobe signals caused by the rise in the ground level, and to conform to the total output current rating.

Moreover, connect the current supply source with each POWER pins and GND pins of this device at low impedance. It is also advisable that a ceramic capacitor of approximately 0.1  $\mu\text{F}$  be connected as a bypass capacitor between VCC and VSS near this device.

### Power supply pins

A malfunction may occur when the power supply voltage fluctuates rapidly even though the fluctuation is within the guaranteed operating range of the VCC power supply voltage. As a rule of voltage stabilization, suppress voltage fluctuation so that the fluctuation in VCC ripple (peak-to-peak value) at the commercial frequency (50 Hz/60 Hz) does not exceed 10% of the standard VCC value, and the transient fluctuation rate does not exceed 0.1 V/ $\mu\text{s}$  at a momentary fluctuation such as switching the power supply.

### Crystal oscillator circuit

Noise near the X0/X1 and X0A/X1A pins may cause the device to malfunction. Design the printed circuit board so that X0/X1, X0A/X1A pins, the crystal oscillator (or ceramic oscillator), and the bypass capacitor to ground are located as close to the device as possible.

It is strongly recommended that the PC board artwork be designed such that the X0/X1 and X0A/X1A pins are surrounded by ground plane as this is expected to produce stable operation.

Evaluate oscillation of your using crystal oscillator by your mount board.

### Sub crystal oscillator

This series sub oscillator circuit is low gain to keep the low current consumption.

The crystal oscillator to fill the following conditions is recommended for sub crystal oscillator to stabilize the oscillation.

- Surface mount type
  - Size: More than 3.2 mm x 1.5 mm
  - Load capacitance: Approximately 6 Pf to 7 Pf
- Lead type
  - Load capacitance: Approximately 6 Pf to 7 Pf

### Using an external clock

When using an external clock as an input of the main clock, set X0/X1 to the external clock input, and input the clock to X0. X1(PE3) can be used as a general-purpose I/O port.

Similarly, when using an external clock as an input of the sub clock, set X0A/X1A to the external clock input, and input the clock to X0A. X1A (P47) can be used as a general-purpose I/O port.

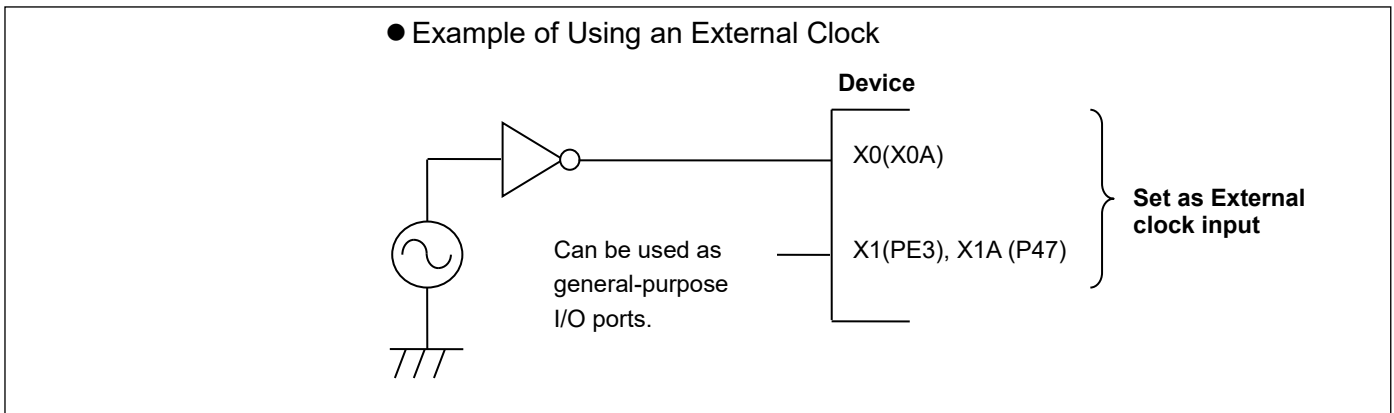

**Handling when using Multi-function serial pin as I<sup>2</sup>C pin**

If it is using the multi-function serial pin as I<sup>2</sup>C pins, P-ch transistor of digital output is always disabled. However, I<sup>2</sup>C pins need to keep the electrical characteristic like other pins and not to connect to the external I<sup>2</sup>C bus system with power OFF.

**C Pin**

This series contains the regulator. Be sure to connect a smoothing capacitor (C<sub>s</sub>) for the regulator between the C pin and the GND pin. Please use a ceramic capacitor or a capacitor of equivalent frequency characteristics as a smoothing capacitor. However, some laminated ceramic capacitors have the characteristics of capacitance variation due to thermal fluctuation (F characteristics and Y5V characteristics). Please select the capacitor that meets the specifications in the operating conditions to use by evaluating the temperature characteristics of a capacitor. A smoothing capacitor of about 4.7 Mf would be recommended for this series.

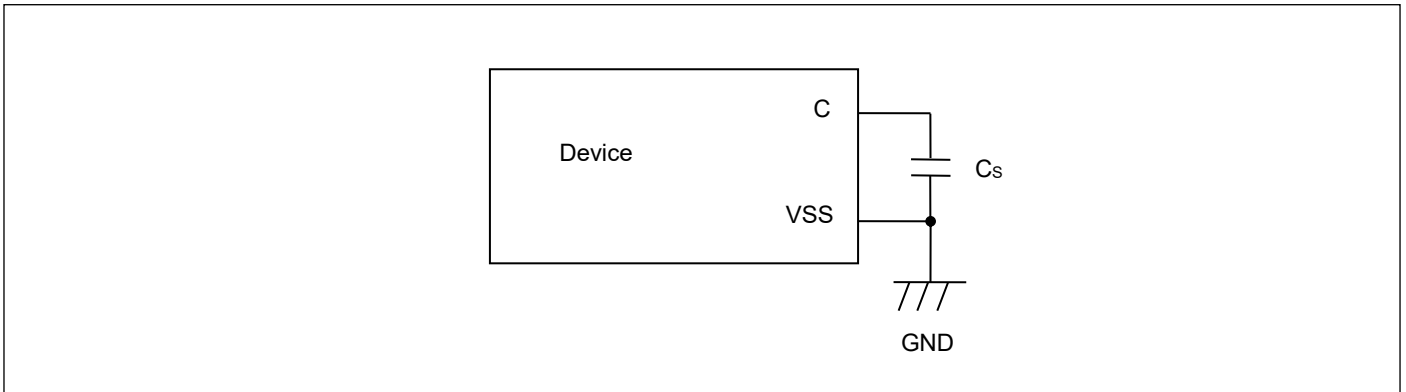

**Mode pins (MD0)**

Connect the MD pin (MD0) directly to VCC or VSS pins. Design the printed circuit board such that the pull-up/down resistance stays low, as well as the distance between the mode pins and VCC pins or VSS pins is as short as possible and the connection impedance is low, when the pins are pulled-up/down such as for switching the pin level and rewriting the Flash memory data. It is because of preventing the device erroneously switching to test mode due to noise.

**Notes on power-on**

Turn power on/off in the following order or at the same time. The device operates normally after all power on.

VBAT only Power-on is possible when VBAT and VCC turns Power-on and Hibernation control is setting and then VCC turns Power-off. About Hibernation control, see Chapter 7-2: VBAT Domain(A) in FM4 Family Peripheral Manual Main Part(002-04856). If not using the A/D converter and D/A converter, connect AVCC = VCC and AVSS = VSS.

- Turning on : VBAT → VCC
- VCC → AVCC → AVRH
- Turning off : AVRH → AVCC → VCC
- VCC → VBAT

**Serial Communication**

There is a possibility to receive wrong data due to the noise or other causes on the serial communication. Therefore, design a printed circuit board so as to avoid noise.

Consider the case of receiving wrong data due to noise, perform error detection such as by applying a checksum of data at the end. If an error is detected, retransmit the data.

**Differences in features among the products with different memory sizes and between Flash products and MASK products**

The electric characteristics including power consumption, ESD, latch-up, noise characteristics, and oscillation characteristics among the products with different memory sizes and between Flash products and MASK products are different because chip layout and memory structures are different.

If you are switching to use a different product of the same series, please make sure to evaluate the electric characteristics.

**Pull-Up function of 5V tolerant I/O**

Please do not input the signal more than VCC voltage at the time of Pull-Up function use of 5V tolerant I/O.

**Adjoining wiring on circuit board**

If wiring of the crystal oscillation circuit X1A adjoins and also runs in parallel with the wiring of P48/VREGCTL, there is a possibility that the oscillation erroneously counts because X1A has noise with the change of P48/VREGCTL. Keep as much distance as possible between both wirings and insert the ground pattern between them in order to avoid this possibility.

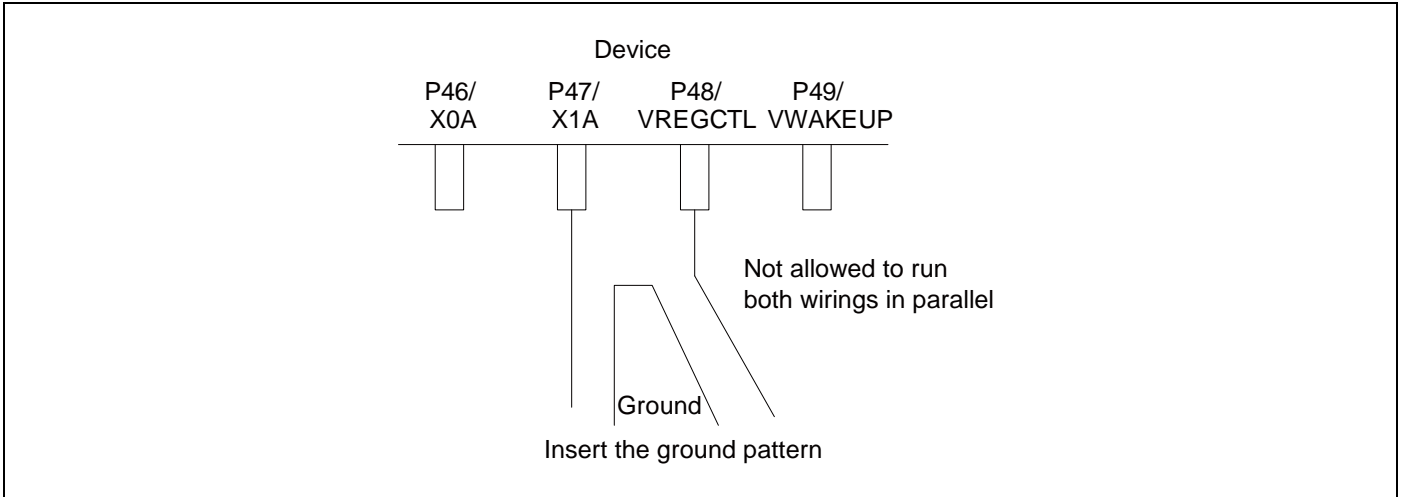

**Handling when using debug pins**

When debug pins(TDO/TMS/TDI/TCK/TRSTX or SWO/SWDIO/SWCLK) are set to GPIO or other peripheral functions, only set them as output, do not set them as input.

### 8. Block Diagram

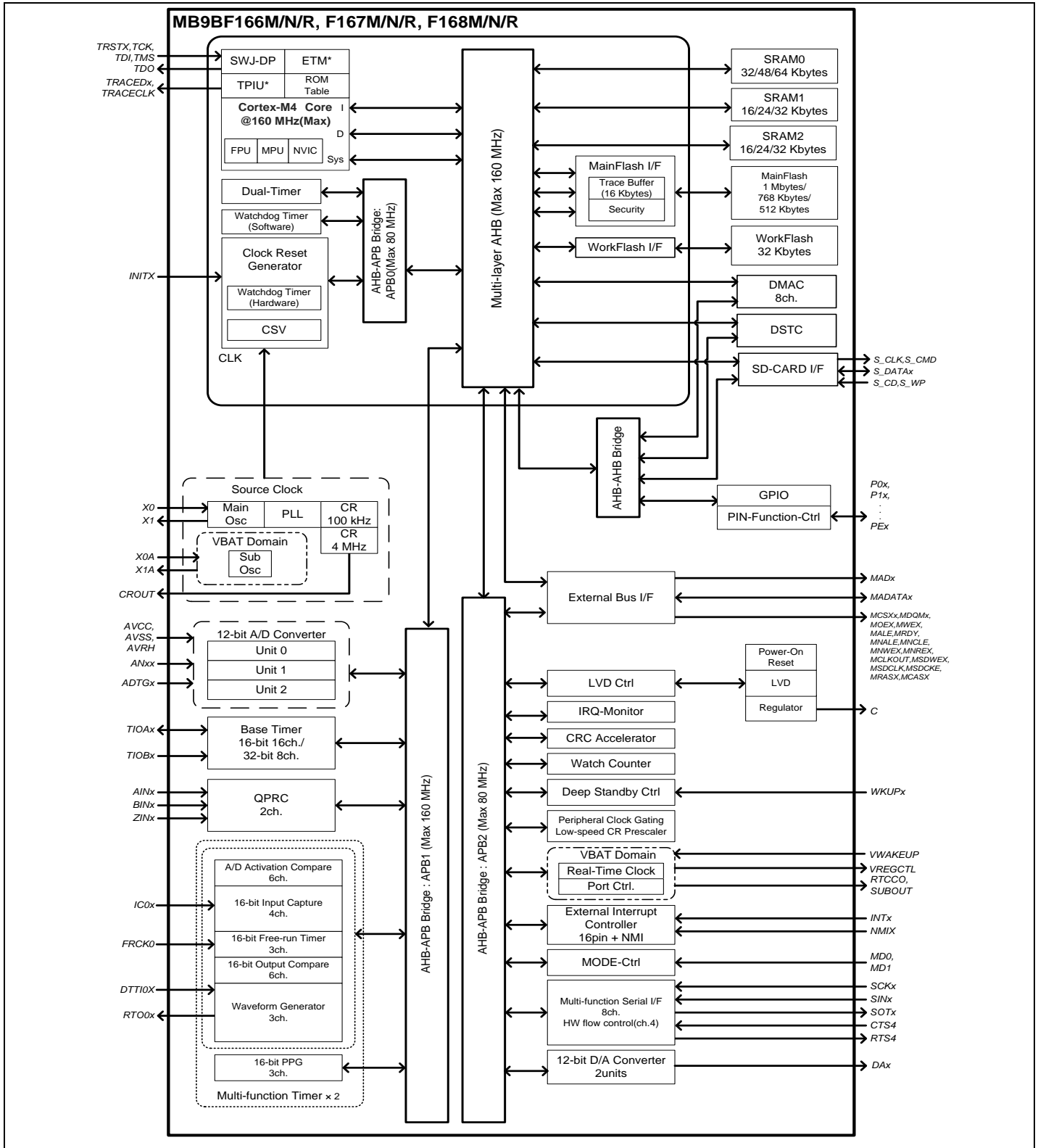

\*: For the MB9BF166M, MB9BF167M and MB9BF168M, ETM is not available.

### 9. Memory Size

See "Memory size" in "Product Lineup" to confirm the memory size.

### 10. Memory Map

#### Memory Map (1)

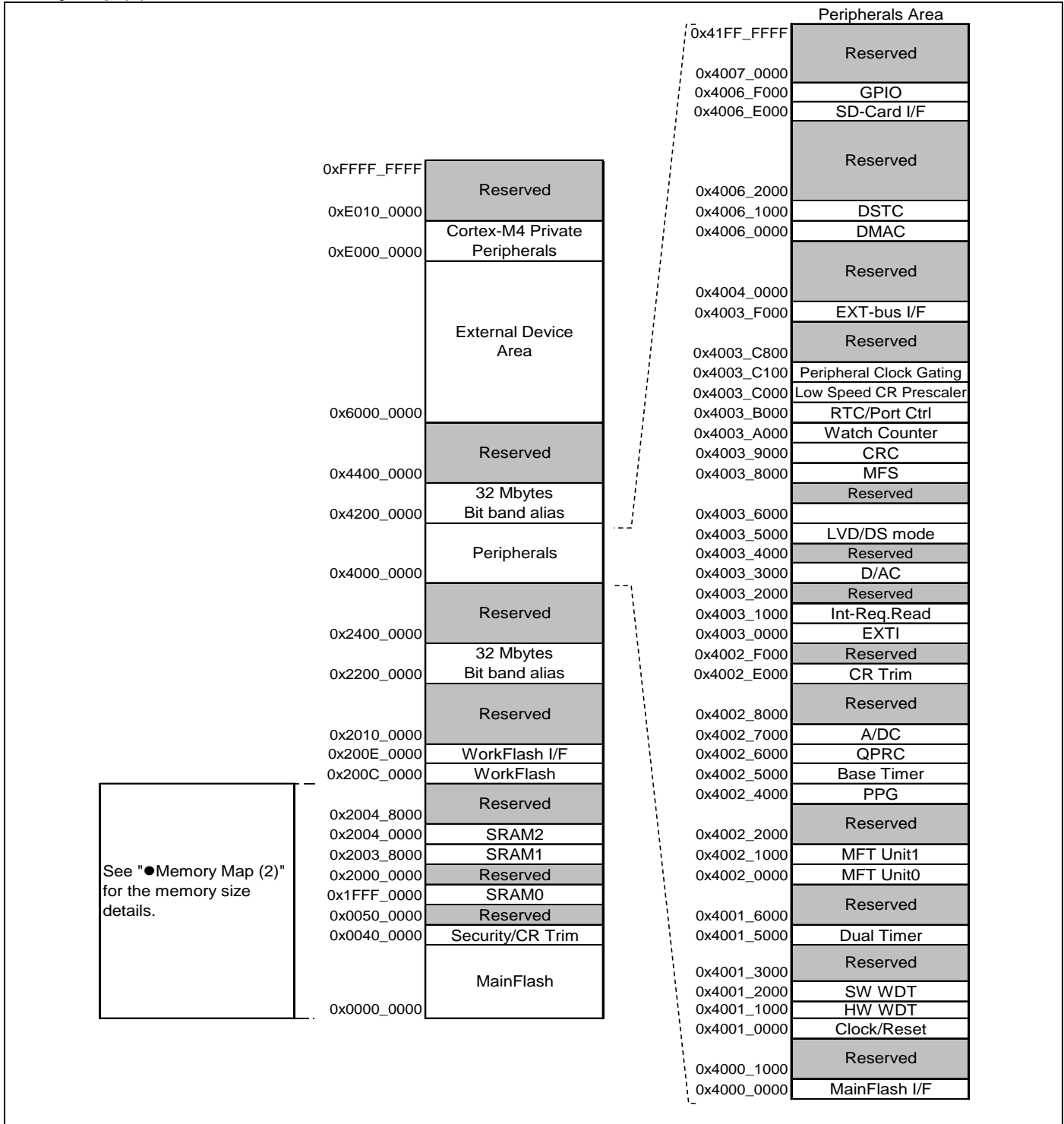

Memory Map (2)

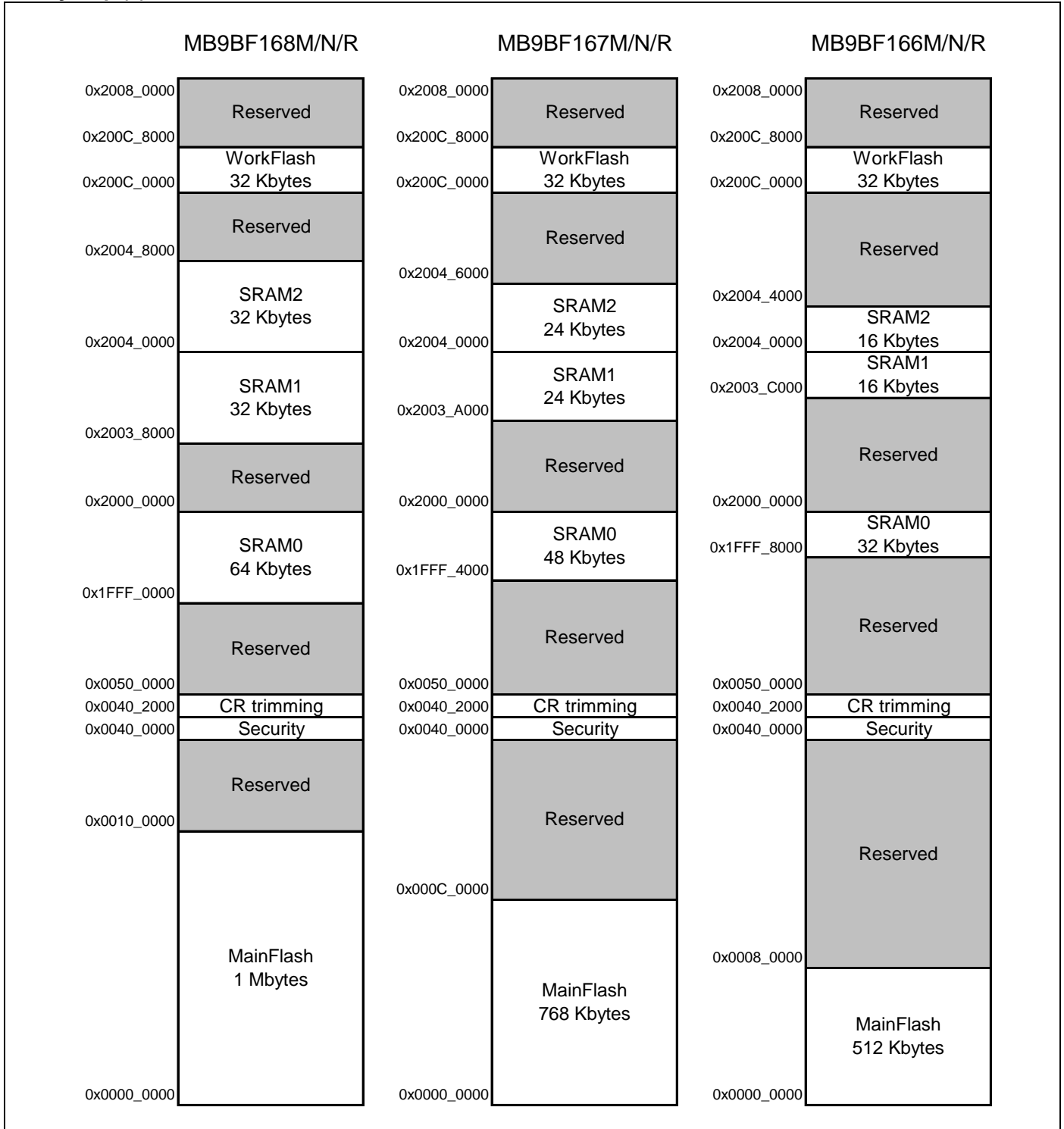

**Peripheral Address Map**

Start address	End address	Bus	Peripherals	
0x4000_0000	0x4000_0FFF	AHB	MainFlash I/F register	
0x4000_1000	0x4000_FFFF		Reserved	
0x4001_0000	0x4001_0FFF	APB0	Clock/Reset Control	
0x4001_1000	0x4001_1FFF		Hardware Watchdog timer	
0x4001_2000	0x4001_2FFF		Software Watchdog timer	
0x4001_3000	0x4001_4FFF		Reserved	
0x4001_5000	0x4001_5FFF		Dual-Timer	
0x4001_6000	0x4001_FFFF		Reserved	
0x4002_0000	0x4002_0FFF		APB1	Multi-function timer unit0
0x4002_1000	0x4002_1FFF	Multi-function timer unit1		
0x4002_2000	0x4003_FFFF	Reserved		
0x4002_4000	0x4002_4FFF	PPG		
0x4002_5000	0x4002_5FFF	Base Timer		
0x4002_6000	0x4002_6FFF	Quadrature Position/Revolution Counter		
0x4002_7000	0x4002_7FFF	A/D Converter		
0x4002_8000	0x4002_DFFF	Reserved		
0x4002_E000	0x4002_EFFF	Internal CR trimming		
0x4002_F000	0x4002_FFFF	Reserved		
0x4003_0000	0x4003_0FFF	APB2		External Interrupt Controller
0x4003_1000	0x4003_1FFF		Interrupt Request Batch-Read Function	
0x4003_2000	0x4003_4FFF		Reserved	
0x4003_3000	0x4003_3FFF		D/A Converter	
0x4003_4000	0x4003_4FFF		Reserved	
0x4003_5000	0x4003_57FF		Low Voltage Detector	
0x4003_5800	0x4003_5FFF		Deep standby mode Controller	
0x4003_6000	0x4003_7FFF		Reserved	
0x4003_8000	0x4003_8FFF		Multi-function serial Interface	
0x4003_9000	0x4003_9FFF		CRC	
0x4003_A000	0x4003_AFFF		Watch Counter	
0x4003_B000	0x4003_BFFF		RTC/Port Ctrl	
0x4003_C000	0x4003_C0FF		Low-speed CR Prescaler	
0x4003_C100	0x4003_C7FF		Peripheral Clock Gating	
0x4003_C800	0x4003_EFFF		Reserved	
0x4003_F000	0x4003_FFFF		External Memory interface	
0x4004_0000	0x4005_FFFF		AHB	Reserved
0x4006_0000	0x4006_0FFF			DMAC register
0x4006_1000	0x4006_3FFF			DSTC register
0x4006_4000	0x4006_DFFF			Reserved
0x4006_E000	0x4006_EFFF	SD-Card I/F		
0x4006_F000	0x4006_FFFF	GPIO		
0x4006_7000	0x41FF_FFFF	Reserved		
0x200E_0000	0x200E_FFFF	WorkFlash I/F register		

## 11. Pin Status in Each CPU State

The terms used for pin status have the following meanings.

■ **INITX = 0**

This is the period when the INITX pin is the “L” level.

■ **INITX = 1**

This is the period when the INITX pin is the “H” level.

■ **SPL = 0**

This is the status that the standby pin level setting bit (SPL) in the standby mode control register (STB\_CTL) is set to “0”.

■ **SPL = 1**

This is the status that the standby pin level setting bit (SPL) in the standby mode control register (STB\_CTL) is set to “1”.

■ **Input enabled**

Indicates that the input function can be used.

■ **Internal input fixed at “0”**

This is the status that the input function cannot be used. Internal input is fixed at “L”.

■ **Hi-Z**

Indicates that the pin drive transistor is disabled and the pin is put in the Hi-Z state.

■ **Setting disabled**

Indicates that the setting is disabled.

■ **Maintain previous state**

Maintains the state that was immediately prior to entering the current mode.  
If a built-in peripheral function is operating, the output follows the peripheral function.  
If the pin is being used as a port, that output is maintained.

■ **Analog input is enabled**

Indicates that the analog input is enabled.

■ **Trace output**

Indicates that the trace function can be used.

■ **GPIO selected**

In Deep standby mode, pins switch to the general-purpose I/O port.

■ **Setting prohibition**

Prohibition of a setting by specification limitation.

**List of Pin Status**

Pin status type	Function group	Power-on reset or low-voltage detection state	INITX input state	Device internal reset state	Run mode or SLEEP mode state	TIMER mode, RTC mode, or STOP mode state		Deep standby RTC mode or Deep standby STOP mode state		Return from Deep standby mode state
		Power supply unstable	Power supply stable		Power supply stable	Power supply stable		Power supply stable		Power supply stable
		-	INITX = 0	INITX = 1	INITX = 1	INITX = 1		INITX = 1		INITX = 1
		-	-	-	-	SPL = 0	SPL = 1	SPL = 0	SPL = 1	-
A	GPIO selected	Setting disabled	Setting disabled	Setting disabled	Maintain previous state	Maintain previous state	Hi-Z / Internal input fixed at "0"	GPIO selected Internal input fixed at "0"	Hi-Z / Internal input fixed at "0"	GPIO selected
	Main crystal oscillator input pin/ External main clock input selected	Input enabled	Input enabled	Input enabled	Input enabled	Input enabled	Input enabled	Input enabled	Input enabled	Input enabled
B	GPIO selected	Setting disabled	Setting disabled	Setting disabled	Maintain previous state	Maintain previous state	Hi-Z / Internal input fixed at "0"	GPIO selected Internal input fixed at "0"	Hi-Z / Internal input fixed at "0"	GPIO selected
	External main clock input selected	Setting disabled	Setting disabled	Setting disabled	Maintain previous state	Maintain previous state	Hi-Z / Internal input fixed at "0"	Maintain previous state	Hi-Z / Internal input fixed at "0"	Maintain previous state
	Main crystal oscillator output pin	Hi-Z / Internal input fixed at "0"/ or Input enable	Hi-Z / Internal input fixed at "0"	Hi-Z / Internal input fixed at "0"	Maintain previous state/When oscillation stops*1, Hi-Z / Internal input fixed at "0"	Maintain previous state/When oscillation stops*1, Hi-Z / Internal input fixed at "0"	Maintain previous state/When oscillation stops*1, Hi-Z / Internal input fixed at "0"	Maintain previous state/When oscillation stops*1, Hi-Z / Internal input fixed at "0"	Maintain previous state/When oscillation stops*1, Hi-Z / Internal input fixed at "0"	Maintain previous state/When oscillation stops*1, Hi-Z / Internal input fixed at "0"
C	INITX input pin	Pull-up / Input enabled	Pull-up / Input enabled	Pull-up / Input enabled	Pull-up / Input enabled	Pull-up / Input enabled	Pull-up / Input enabled	Pull-up / Input enabled	Pull-up / Input enabled	Pull-up / Input enabled
D	Mode input pin	Input enabled	Input enabled	Input enabled	Input enabled	Input enabled	Input enabled	Input enabled	Input enabled	Input enabled
E	Mode input pin	Input enabled	Input enabled	Input enabled	Input enabled	Input enabled	Input enabled	Input enabled	Input enabled	Input enabled
	GPIO selected	Setting disabled	Setting disabled	Setting disabled	Maintain previous state	Maintain previous state	Hi-Z / Input enabled	GPIO selected	Hi-Z / Input enabled	GPIO selected

Pin status type	Function group	Power-on reset or low-voltage detection state	INITX input state	Device internal reset state	Run mode or SLEEP mode state	TIMER mode, RTC mode, or STOP mode state		Deep standby RTC mode or Deep standby STOP mode state		Return from Deep standby mode state			
		Power supply unstable	Power supply stable		Power supply stable	Power supply stable		Power supply stable		Power supply stable			
		-	INITX = 0	INITX = 1	INITX = 1	INITX = 1		INITX = 1		INITX = 1			
		-	-	-	-	SPL = 0	SPL = 1	SPL = 0	SPL = 1	-			
F	NMIX selected	Setting disabled	Setting disabled	Setting disabled	Maintain previous state	Maintain previous state	Maintain previous state	WKUP input enabled	Hi-Z / WKUP input enabled	GPIO selected			
	Resource other than above selected	Hi-Z	Hi-Z / Input enabled	Hi-Z / Input enabled			Hi-Z / Internal input fixed at "0"						
	GPIO selected						Maintain previous state						
G	JTAG selected	Hi-Z	Pull-up / Input enabled	Pull-up / Input enabled	Maintain previous state	Maintain previous state	Maintain previous state	Maintain previous state	Maintain previous state	Maintain previous state			
	GPIO selected	Setting disabled	Setting disabled	Setting disabled			Hi-Z / Internal input fixed at "0"				GPIO selected Internal input fixed at "0"	Hi-Z / Internal input fixed at "0"	GPIO selected
H	JTAG selected	Hi-Z	Pull-up / Input enabled	Pull-up / Input enabled	Maintain previous state	Maintain previous state	Maintain previous state	Maintain previous state	Maintain previous state	Maintain previous state			
	Resource other than above selected	Setting disabled	Setting disabled	Setting disabled			Hi-Z / Internal input fixed at "0"				GPIO selected Internal input fixed at "0"	Hi-Z / Internal input fixed at "0"	GPIO selected
	GPIO selected												
I	Resource selected	Hi-Z	Hi-Z / Input enabled	Hi-Z / Input enabled	Maintain previous state	Maintain previous state	Hi-Z / Internal input fixed at "0"	GPIO selected Internal input fixed at "0"	Hi-Z / Internal input fixed at "0"	GPIO selected			
	GPIO selected												
J	Analog output selected	Setting disabled	Setting disabled	Setting disabled	Maintain previous state	*2	*3	GPIO selected Internal input fixed at "0"	Hi-Z / Internal input fixed at "0"	GPIO selected			
	Resource other than above selected	Hi-Z	Hi-Z / Input enabled	Hi-Z / Input enabled		Maintain previous state	Maintain previous state				Hi-Z / Internal input fixed at "0"		
	GPIO selected												

Pin status type	Function group	Power-on reset or low-voltage detection state	INITX input state	Device internal reset state	Run mode or SLEEP mode state	TIMER mode, RTC mode, or STOP mode state		Deep standby RTC mode or Deep standby STOP mode state		Return from Deep standby mode state	
		Power supply unstable	Power supply stable		Power supply stable	Power supply stable		Power supply stable		Power supply stable	
		-	INITX = 0	INITX = 1	INITX = 1	INITX = 1		INITX = 1		INITX = 1	
		-	-	-	-	SPL = 0	SPL = 1	SPL = 0	SPL = 1	-	
K	External interrupt enabled selected	Setting disabled	Setting disabled	Setting disabled	Maintain previous state	Maintain previous state	Maintain previous state	GPIO selected Internal input fixed at "0"	Hi-Z / Internal input fixed at "0"	GPIO selected	
	Resource other than above selected	Hi-Z	Hi-Z / Input enabled	Hi-Z / Input enabled			Hi-Z / Internal input fixed at "0"				
	GPIO selected										
L	Analog input selected	Hi-Z	Hi-Z / Internal input fixed at "0" / Analog input enabled	Hi-Z / Internal input fixed at "0" / Analog input enabled	Hi-Z / Internal input fixed at "0" / Analog input enabled	Hi-Z / Internal input fixed at "0" / Analog input enabled	Hi-Z / Internal input fixed at "0" / Analog input enabled	Hi-Z / Internal input fixed at "0" / Analog input enabled	Hi-Z / Internal input fixed at "0" / Analog input enabled	Hi-Z / Internal input fixed at "0" / Analog input enabled	
	Resource other than above selected		Setting disabled	Setting disabled	Setting disabled	Maintain previous state	Maintain previous state	Hi-Z / Internal input fixed at "0"	GPIO selected Internal input fixed at "0"	Hi-Z / Internal input fixed at "0"	GPIO selected
	GPIO selected										
M	Analog input selected	Hi-Z	Hi-Z / Internal input fixed at "0" / Analog input enabled	Hi-Z / Internal input fixed at "0" / Analog input enabled	Hi-Z / Internal input fixed at "0" / Analog input enabled	Hi-Z / Internal input fixed at "0" / Analog input enabled	Hi-Z / Internal input fixed at "0" / Analog input enabled	Hi-Z / Internal input fixed at "0" / Analog input enabled	Hi-Z / Internal input fixed at "0" / Analog input enabled	Hi-Z / Internal input fixed at "0" / Analog input enabled	
	External interrupt enabled selected		Setting disabled	Setting disabled	Setting disabled	Maintain previous state	Maintain previous state	Maintain previous state	GPIO selected Internal input fixed at "0"	Hi-Z / Internal input fixed at "0"	GPIO selected
	Resource other than above selected							Hi-Z / Internal input fixed at "0"			
	GPIO selected						Hi-Z / Internal input fixed at "0"				

Pin status type	Function group	Power-on reset or low-voltage detection state	INITX input state	Device internal reset state	Run mode or SLEEP mode state	TIMER mode, RTC mode, or STOP mode state		Deep standby RTC mode or Deep standby STOP mode state		Return from Deep standby mode state
		Power supply unstable	Power supply stable		Power supply stable	Power supply stable		Power supply stable		Power supply stable
		-	INITX = 0	INITX = 1	INITX = 1	INITX = 1		INITX = 1		INITX = 1
		-	-	-	-	SPL = 0	SPL = 1	SPL = 0	SPL = 1	-
N	Analog input selected	Hi-Z	Hi-Z / Internal input fixed at "0" / Analog input enabled	Hi-Z / Internal input fixed at "0" / Analog input enabled	Hi-Z / Internal input fixed at "0" / Analog input enabled	Hi-Z / Internal input fixed at "0" / Analog input enabled	Hi-Z / Internal input fixed at "0" / Analog input enabled	Hi-Z / Internal input fixed at "0" / Analog input enabled	Hi-Z / Internal input fixed at "0" / Analog input enabled	Hi-Z / Internal input fixed at "0" / Analog input enabled
	Trace selected	Setting disabled	Setting disabled	Setting disabled	Maintain previous state	Maintain previous state	Trace output	GPIO selected	Hi-Z / Internal input fixed at "0"	GPIO selected
	Resource other than above selected						Hi-Z / Internal input fixed at "0"			
GPIO selected										
O	Analog input selected	Hi-Z	Hi-Z / Internal input fixed at "0" / Analog input enabled	Hi-Z / Internal input fixed at "0" / Analog input enabled	Hi-Z / Internal input fixed at "0" / Analog input enabled	Hi-Z / Internal input fixed at "0" / Analog input enabled	Hi-Z / Internal input fixed at "0" / Analog input enabled	Hi-Z / Internal input fixed at "0" / Analog input enabled	Hi-Z / Internal input fixed at "0" / Analog input enabled	Hi-Z / Internal input fixed at "0" / Analog input enabled
	Trace selected	Setting disabled	Setting disabled	Setting disabled	Maintain previous state	Maintain previous state	Trace output	GPIO selected	Hi-Z / Internal input fixed at "0"	GPIO selected
	External interrupt enabled selected						Maintain previous state			
	Resource other than above selected						Hi-Z / Internal input fixed at "0"			
GPIO selected										

Pin status type	Function group	Power-on reset or low-voltage detection state	INITX input state	Device internal reset state	Run mode or SLEEP mode state	TIMER mode, RTC mode, or STOP mode state		Deep standby RTC mode or Deep standby STOP mode state		Return from Deep standby mode state
		Power supply unstable	Power supply stable		Power supply stable	Power supply stable		Power supply stable		Power supply stable
		-	INITX = 0	INITX = 1	INITX = 1	INITX = 1		INITX = 1		INITX = 1
		-	-	-	-	SPL = 0	SPL = 1	SPL = 0	SPL = 1	-
P	Analog input selected	Hi-Z	Hi-Z / Internal input fixed at „0“ / Analog input enabled	Hi-Z / Internal input fixed at „0“ / Analog input enabled	Hi-Z / Internal input fixed at „0“ / Analog input enabled	Hi-Z / Internal input fixed at „0“ / Analog input enabled	Hi-Z / Internal input fixed at „0“ / Analog input enabled	Hi-Z / Internal input fixed at „0“ / Analog input enabled	Hi-Z / Internal input fixed at „0“ / Analog input enabled	Hi-Z / Internal input fixed at „0“ / Analog input enabled
	WKUP enabled	Setting disabled	Setting disabled	Setting disabled	Maintain previous state	Maintain previous state	Maintain previous state	WKUP input enabled	Hi-Z / WKUP input enabled	GPIO selected
	Resource other than above selected						Hi-Z / Internal input fixed at „0“	GPIO selected Internal input fixed at „0“	Hi-Z / Internal input fixed at „0“	
GPIO selected										
Q	WKUP enabled	Setting disabled	Setting disabled	Setting disabled	Maintain previous state	Maintain previous state	Maintain previous state	WKUP input enabled	Hi-Z / WKUP input enabled	GPIO selected
	External interrupt enabled selected							GPIO selected	Hi-Z / Internal input fixed at „0“	
	Resource other than above selected	Hi-Z	Hi-Z / Input enabled	Hi-Z / Input enabled				Hi-Z / Internal input fixed at „0“	Internal input fixed at „0“	
	GPIO selected									
R	GPIO selected	Hi-Z	Hi-Z / Input enabled	Hi-Z / Input enabled	Maintain previous state	Maintain previous state	Hi-Z / Internal input fixed at „0“	GPIO selected Internal input fixed at „0“	Hi-Z / Internal input fixed at „0“	GPIO selected

\*1: Oscillation is stopped at Sub timer mode, sub CR timer mode, RTC mode, STOP mode, Deep standby RTC mode, and Deep standby STOP mode.

\*2: Maintain previous state at timer mode. GPIO selected Internal input fixed at „0“ at RTC mode, STOP mode.

\*3: Maintain previous state at timer mode. Hi-Z/Internal input fixed at „0“ at RTC mode, STOP mode.

List of VBAT Domain Pin Status

VBAT pin status type	Function group	Power-on reset*1	INITX input state	Device internal reset state	Run mode or SLEEP mode state	TIMER mode, RTC mode, or STOP mode state		Deep standby RTC mode or Deep standby STOP mode state		Return from Deep standby mode state	VBAT RTC mode state	Return from VBAT RTC mode state
		Power supply unstable	Power supply stable		Power supply stable	Power supply stable		Power supply stable		Power supply stable	Power supply stable	Power supply stable
		-	INITX = 0	INITX = 1	INITX = 1	INITX = 1		INITX = 1		INITX = 1	-	-
		-	-	-	-	SPL = 0	SPL = 1	SPL = 0	SPL = 1	-	-	-
S	GPIO selected	Setting disabled	Maintain Previous state	Maintain Previous state	Maintain previous state	Maintain previous state	Maintain Previous state	Maintain Previous state	Maintain Previous state	Maintain Previous state	Setting prohibition	-
	Sub crystal oscillator input pin / External sub clock input selected	Input enabled	Input enabled	Input enabled	Input enabled	Input enabled	Input enabled	Input enabled	Input enabled	Input enabled	Maintain previous state	Maintain previous state
T	GPIO selected	Setting disabled	Maintain Previous state	Maintain Previous state	Maintain previous state	Maintain previous state	Maintain Previous state	Maintain Previous state	Maintain Previous state	Maintain Previous state	Setting prohibition	-
	External sub clock input selected	Setting disabled	Maintain Previous state	Maintain Previous state	Maintain previous state	Maintain previous state	Maintain Previous state	Maintain Previous state	Maintain Previous state	Maintain previous state	Maintain previous state	Maintain previous state
	Sub crystal oscillator output pin	Hi-Z / Internal input fixed at "0" / or Input enable	Maintain Previous state	Maintain Previous state	Maintain previous state	Maintain previous state/When oscillation stops, Hi-Z*2	Maintain previous state/When oscillation stops, Hi-Z*2	Maintain previous state/When oscillation stops, Hi-Z*2	Maintain previous state/When oscillation stops, Hi-Z*2	Maintain Previous state	Maintain previous state	Maintain previous state
U	Resource selected	Hi-Z	Maintain previous state	Maintain previous state	Maintain previous state	Maintain previous state	Maintain previous state	Maintain previous state	Maintain previous state	Maintain previous state	Maintain previous state	Maintain previous state
	GPIO selected		Maintain previous state	Maintain previous state	Maintain previous state	Maintain previous state	Maintain previous state	Maintain previous state	Maintain previous state	Maintain previous state	Maintain previous state	Maintain previous state

\*1: When VBAT and VCC power on.

\*2: When the SOSCNTL bit in the WTOSCCNT register is 0, the sub crystal oscillator output pin is maintained in the previous state. When the SOSCNTL bit in the WTOSCCNT register is 1, oscillation is stopped at Stop mode and Deep Standby Stop

## 12. Electrical Characteristics

### 12.1 Absolute Maximum Ratings

Parameter	Symbol	Rating		Unit	Remarks
		Min	Max		
Power supply voltage *1, *2	$V_{CC}$	$V_{SS} - 0.5$	$V_{SS} + 6.5$	V	
Power supply voltage (VBAT) *1, *3	$V_{BAT}$	$V_{SS} - 0.5$	$V_{SS} + 6.5$	V	
Analog power supply voltage *1, *4	$AV_{CC}$	$V_{SS} - 0.5$	$V_{SS} + 6.5$	V	
Analog reference voltage *1, *4	$AVRH$	$V_{SS} - 0.5$	$V_{SS} + 6.5$	V	
Input voltage *1	$V_I$	$V_{SS} - 0.5$	$V_{CC} + 0.5$ ( $\leq 6.5V$ )	V	
		$V_{SS} - 0.5$	$V_{SS} + 6.5$	V	5V tolerant
Analog pin input voltage *1	$V_{IA}$	$V_{SS} - 0.5$	$AV_{CC} + 0.5$ ( $\leq 6.5V$ )	V	
Output voltage *1	$V_O$	$V_{SS} - 0.5$	$V_{CC} + 0.5$ ( $\leq 6.5V$ )	V	
"L" level maximum output current *5	$I_{OL}$	-	10	Ma	4Ma type
			20	Ma	8Ma type
			20	Ma	12Ma type
			22.4	Ma	I <sup>2</sup> C Fm+
"L" level average output current *6	$I_{OLAV}$	-	4	Ma	4Ma type
			8	Ma	8Ma type
			12	Ma	12Ma type
			20	Ma	I <sup>2</sup> C Fm+
"L" level total maximum output current	$\sum I_{OL}$	-	100	Ma	
"L" level total maximum output current *7	$\sum I_{OLAV}$	-	50	Ma	
"H" level maximum output current *5	$I_{OH}$	-	- 10	Ma	4Ma type
			20	Ma	8Ma type
			- 20	Ma	12Ma type
"H" level average output current *6	$I_{OHAV}$	-	- 4	Ma	4Ma type
			8	Ma	8Ma type
			- 12	Ma	12Ma type
"H" level total maximum output current	$\sum I_{OH}$	-	- 100	Ma	
"H" level total average output current *7	$\sum I_{OHAV}$	-	- 50	Ma	
Storage temperature	$T_{STG}$	- 55	+ 150	°C	

\*1: These parameters are based on the condition that  $V_{SS} = AV_{SS} = 0.0V$ .

\*2:  $V_{CC}$  must not drop below  $V_{SS} - 0.5V$ .

\*3:  $V_{BAT}$  must not drop below  $V_{SS} - 0.5V$ .

\*4: Ensure that the voltage does not exceed  $V_{CC} + 0.5V$ , for example, when the power is turned on.

\*5: The maximum output current is defined as the value of the peak current flowing through any one of the corresponding pins.

\*6: The average output current is defined as the average current value flowing through any one of the corresponding pins for a 100ms period.

\*7: The total average output current is defined as the average current value flowing through all of corresponding pins for a 100ms.

#### **WARNING:**

- Semiconductor devices may be permanently damaged by application of stress (including, without limitation, voltage, current or temperature) in excess of absolute maximum ratings. Do not exceed any of these ratings.

**12.2 Recommended Operating Conditions**

Parameter	Symbol	Conditions	Value		Unit	Remarks	
			Min	Max			
Power supply voltage	V <sub>CC</sub>	-	2.7 <sup>*3</sup>	5.5	V		
Power supply voltage (VBAT)	V <sub>BAT</sub>	-	2.7	5.5	V		
Analog power supply voltage	AV <sub>CC</sub>	-	2.7	5.5	V	AV <sub>CC</sub> = V <sub>CC</sub>	
Analog reference voltage	AVRH	-	*2	AV <sub>CC</sub>	V		
Operating temperature	Junction temperature	T <sub>J</sub>	-	- 40	+ 125	°C	
	Ambient temperature	T <sub>A</sub>	-	- 40	*1	°C	

\*1: The maximum temperature of the ambient temperature (T<sub>A</sub>) can guarantee a range that does not exceed the junction temperature (T<sub>J</sub>).

The calculation formula of the ambient temperature (T<sub>A</sub>) is shown below.

$$T_A(\text{Max}) = T_J(\text{Max}) - P_d(\text{Max}) \times \theta_{ja}$$

P<sub>d</sub>: Power dissipation (W)

θ<sub>ja</sub>: Package thermal resistance (°C/W)

$$P_d(\text{Max}) = V_{CC} \times I_{CC}(\text{Max}) + \sum (I_{OL} \times V_{OL}) + \sum ((V_{CC} - V_{OH}) \times (-I_{OH}))$$

I<sub>OL</sub>: "L" level output current

I<sub>OH</sub>: "H" level output current

V<sub>OL</sub>: "L" level output voltage

V<sub>OH</sub>: "H" level output voltage

\*2: The minimum value of Analog reference voltage depends on the value of compare clock cycle (T<sub>ck</sub>). See 12.5. 12-bit A/D Converter" for the details.

\*3: Between less than the minimum power supply voltage and low voltage reset/interrupt detection voltage, instruction execution and low voltage detection function by built-in High-speed CR (including Main PLL is used) or built-in Low-speed CR is possible to operate.

Package thermal resistance and maximum permissible power for each package are shown below.

The operation is guaranteed maximum permissible power or less for semiconductor devices.

**Table for package thermal resistance and maximum permissible power**

Package	Printed circuit board	Thermal resistance θ <sub>ja</sub> (°C/W)	Maximum permissible power (Mw)	
			T <sub>A</sub> = +85°C	T <sub>A</sub> = +105°C
LQH080 (0.5mm pitch)	Single-layered both sides	60	667	333
	4 layers	39	1026	513
LQJ080 (0.65mm pitch)	Single-layered both sides	58	690	335
	4 layers	38	1053	526
LQI100 (0.5mm pitch)	Single-layered both sides	57	702	351
	4 layers	38	1053	526
PQH100 (0.65mm pitch)	Single-layered both sides	48	833	417
	4 layers	34	1177	588
LQM120 (0.5mm pitch)	Single-layered both sides	62	645	323
	4 layers	43	930	465
LDC112 (0.5mm pitch)	Single-layered both sides	60	667	333
	4 layers	40	1000	500
LDC144 (0.5mm pitch)	Single-layered both sides	55	727	364
	4 layers	40	1000	500

**WARNING:**

- The recommended operating conditions are required in order to ensure the normal operation of the semiconductor device. All of the device's electrical characteristics are warranted when the device is operated under these conditions. Any use of semiconductor devices will be under their recommended operating condition. Operation under any conditions other than these conditions may adversely affect reliability of device and could result in device failure. No warranty is made with respect to any use, operating conditions or combinations not represented on this data sheet. If you are considering application under any conditions other than listed herein, please contact sales representatives beforehand.

**Calculation method of power dissipation (Pd)**

The power dissipation is shown in the following formula.

$$Pd = V_{CC} \times I_{CC} + \sum (I_{OL} \times V_{OL}) + \sum ((V_{CC} - V_{OH}) \times (-I_{OH}))$$

$I_{OL}$ : "L" level output current  
 $I_{OH}$ : "H" level output current  
 $V_{OL}$ : "L" level output voltage  
 $V_{OH}$ : "H" level output voltage

$I_{CC}$  is a current consumed in device.

It can be analyzed as follows.

$$I_{CC} = I_{CC}(INT) + \sum I_{CC}(IO)$$

$I_{CC}(INT)$ : Current consumed in internal logic and memory, etc. through regulator

$\sum I_{CC}(IO)$ : Sum of current (I/O switching current) consumed in output pin

For  $I_{CC}(INT)$ , it can be anticipated by 12.3.1 "Current Rating" in 12.3. DC Characteristics" (This rating value does not include  $I_{CC}(IO)$  for a value at pin fixed).

For  $I_{CC}(IO)$ , it depends on system used by customers.

The calculation formula is shown below.

$$I_{CC}(IO) = (C_{INT} + C_{EXT}) \times V_{CC} \times f_{sw}$$

$C_{INT}$ : Pin internal load capacitance  
 $C_{EXT}$ : External load capacitance of output pin  
 $f_{sw}$ : Pin switching frequency

Parameter	Symbol	Conditions	Capacitance value
Pin internal load capacitance	$C_{INT}$	4Ma type	1.93Pf
		8Ma type	3.45Pf
		12Ma type	3.42Pf

Calculate  $I_{CC}(Max)$  as follows when the power dissipation can be evaluated by yourself.

1. Measure current value  $I_{CC}(Typ)$  at normal temperature (+25°C).
2. Add maximum leak current value  $I_{CC}(leak\_max)$  at operating on a value in (1).

$$I_{CC}(Max) = I_{CC}(Typ) + I_{CC}(leak\_max)$$

Parameter	Symbol	Conditions	Current value
Maximum leak current at operating	$I_{CC}(leak\_max)$	$T_j = +125^\circ C$	45.5Ma
		$T_j = +105^\circ C$	26.8Ma
		$T_j = +85^\circ C$	16.2Ma

Current explanation diagram

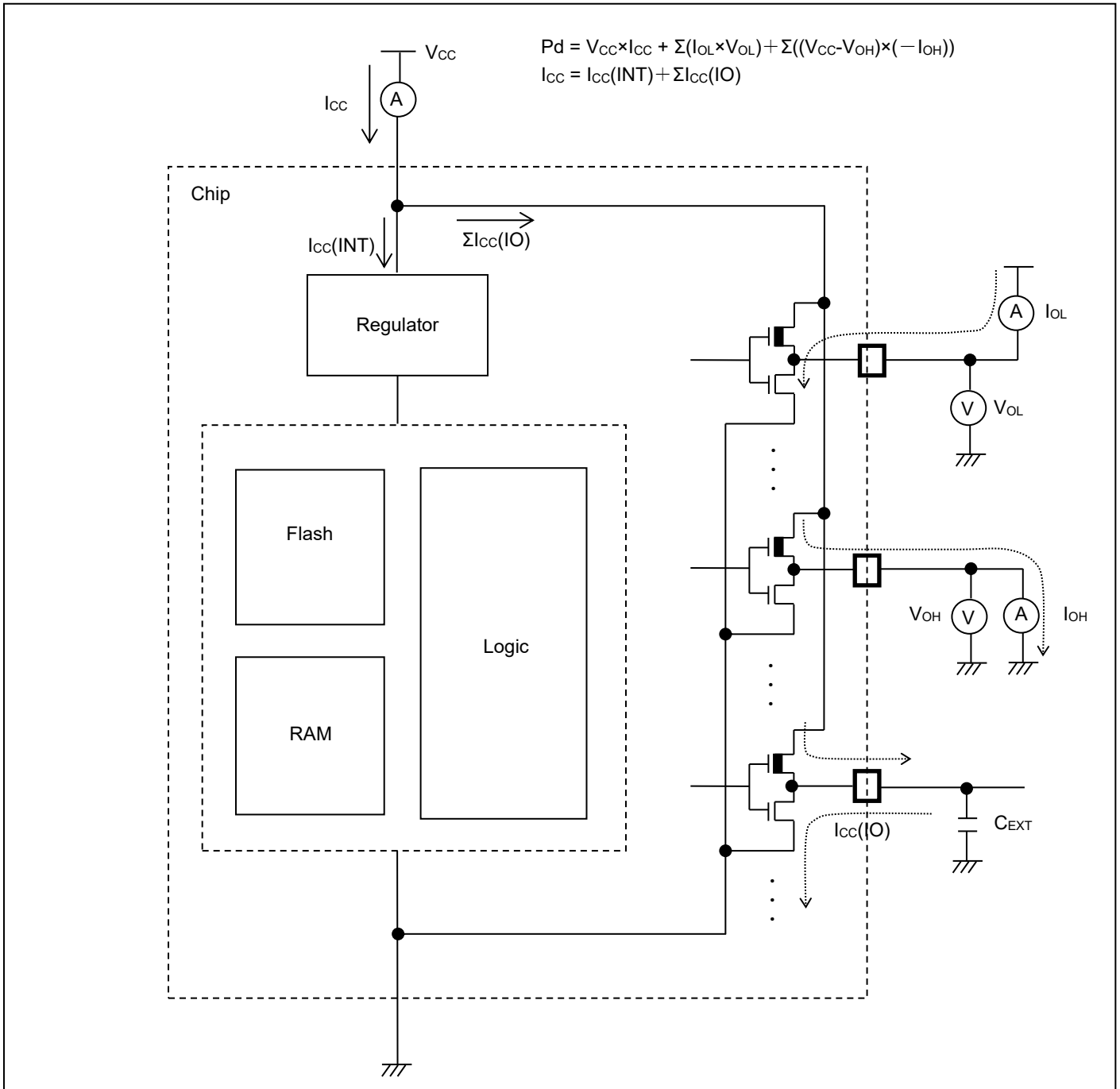

12.3 DC Characteristics

12.3.1 Current Rating

Table 12-1. Typical and maximum current consumption in Normal operation(PLL), code running from Flash memory (Flash accelerator mode and trace buffer function enabled)

Parameter	Symbol	Pin name	Conditions	Frequency*4	Value		Unit	Remarks				
					Typ*1	Max*2						
Power supply current	I <sub>cc</sub>	VCC	Normal operation*5,*6 (PLL)	160MHz	54	103	Ma	*3 When all peripheral clocks are ON				
				144MHz	49	98						
				120MHz	41	90						
				100MHz	35	84						
				80MHz	28	77						
				60MHz	22	71						
				40MHz	16	64						
				20MHz	8.9	58						
				8MHz	5.1	54						
				4MHz	3.8	53						
								160MHz	34	83	Ma	*3 When all peripheral clocks are OFF
								144MHz	31	80		
								120MHz	26	75		
								100MHz	22	71		
								80MHz	18	67		
								60MHz	14	63		
								40MHz	10	59		
								20MHz	6.2	55		
				8MHz	3.8	53						
				4MHz	3.1	52						

Table 12-2. Typical and maximum current consumption in Normal operation(PLL), code with data accessing running from Flash memory (Flash accelerator mode and trace buffer function disabled)

Parameter	Symbol	Pin name	Conditions	Frequency*7	Value		Unit	Remarks				
					Typ*1	Max*2						
Power supply current	I <sub>cc</sub>	VCC	Normal operation*8 (PLL)	160MHz	74	126	Ma	*3 When all peripheral clocks are ON				
				144MHz	68	120						
				120MHz	59	112						
				100MHz	52	104						
				80MHz	44	97						
				60MHz	36	89						
				40MHz	27	79						
				20MHz	17	67						
				8MHz	8.3	58						
				4MHz	5.4	55						
								160MHz	51	103	Ma	*3 When all peripheral clocks are OFF
								144MHz	47	100		
								120MHz	42	94		
								100MHz	37	90		
								80MHz	33	85		
								60MHz	28	80		
								40MHz	21	73		
								20MHz	13	64		
				8MHz	6.9	56						
				4MHz	4.6	54						

\*1: T<sub>A</sub> = +25°C, V<sub>CC</sub> = 3.3V

\*2: T<sub>j</sub> = +125°C, V<sub>CC</sub> = 5.5V

\*3: When all ports are fixed.

\*4: Frequency is a value of HCLK. PCLK0 = PCLK1 = PCLK2 = HCLK/2

\*5: When operating flash accelerator mode and trace buffer function (FRWTR.RWT = 10, FBFCR.BE = 1)

\*6: Data access is nothing to MainFlash memory

\*7: Frequency is a value of HCLK. PCLK0 = PCLK2 = HCLK/2, PCLK1 = HCLK

\*8: When stopping flash accelerator mode and trace buffer function (FRWTR.RWT = 10, FBFCR.BE = 0)

**Table 12-3. Typical and maximum current consumption in Normal operation(PLL), code with data accessing running from Flash memory (flash 0 wait-cycle mode and read access 0 wait)**

Parameter	Symbol	Pin name	Conditions	Frequency*4 (MHz)	Value		Unit	Remarks
					Typ*1	Max*2		
Power supply current	I <sub>CC</sub>	VCC	Normal operation*5 (PLL)	72MHz	46	98	Ma	*3 When all peripheral clocks are ON
				60MHz	40	92		
				48MHz	33	85		
				36MHz	27	78		
				24MHz	19	70		
				12MHz	11	61		
				8MHz	8.5	58		
				4MHz	5.5	55		
				72MHz	33	85	Ma	*3 When all peripheral clocks are OFF
				60MHz	29	81		
				48MHz	25	76		
				36MHz	20	71		
				24MHz	15	65		
				12MHz	9.2	59		
				8MHz	6.9	56		
				4MHz	4.6	54		

\*1: T<sub>A</sub> = +25°C, V<sub>CC</sub> = 3.3V

\*2: T<sub>j</sub> = +125°C, V<sub>CC</sub> = 5.5V

\*3: When all ports are fixed.

\*4: Frequency is a value of HCLK. PCLK0 = PCLK1 = PCLK2 = HCLK

\*5: When 0 wait-cycle mode (FRWTR.RWT = 00, FSYNDN.SD = 00)

**Table 12-4. Typical and maximum current consumption in Normal operation (other than PLL), code with data accessing running from Flash memory (flash 0 wait-cycle mode and read access 0 wait**

Parameter	Symbol	Pin name	Conditions	Frequency*4	Value		Unit	Remarks
					Typ*1	Max*2		
Power supply current	I <sub>CC</sub>	VCC	Normal operation*5 (built-in high-speed CR)	4MHz	3.3	51	Ma	*3 When all peripheral clocks are ON
					2.8	51	Ma	*3 When all peripheral clocks are OFF
			Normal operation*5 (sub oscillation)	32kHz	0.64	48	Ma	*3 When all peripheral clocks are ON
					0.56	48	Ma	*3 When all peripheral clocks are OFF
			Normal operation*5 (built-in low-speed CR)	100kHz	0.64	48	Ma	*3 When all peripheral clocks are ON
					0.58	48	Ma	*3 When all peripheral clocks are OFF

\*1: T<sub>A</sub> = +25°C, V<sub>CC</sub> = 3.3V

\*2: T<sub>j</sub> = +125°C, V<sub>CC</sub> = 5.5V

\*3: When all ports are fixed.

\*4: Frequency is a value of HCLK. PCLK0 = PCLK1 = PCLK2 = HCLK/2

\*5: When 0 wait-cycle mode (FRWTR.RWT = 00, FSYNDN.SD = 000)

**Table 12-5. Typical and maximum current consumption in Sleep operation(PLL), when PCLK0 = PCLK1 = PCLK2 = HCLK/2**

Parameter	Symbol	Pin name	Conditions	Frequency*4	Value		Unit	Remarks
					Typ*1	Max*2		
Power supply current	I <sub>ccs</sub>	VCC	Sleep operation (PLL)	160MHz	35	84	Ma	*3 When all peripheral clocks are ON
				144MHz	32	81		
				120MHz	27	76		
				100MHz	23	72		
				80MHz	19	68		
				60MHz	15	64		
				40MHz	11	60		
				20MHz	6.5	55		
				8MHz	4.1	53		
				4MHz	3.3	52	Ma	*3 When all peripheral clocks are OFF
				160MHz	16	65		
				144MHz	14	63		
				120MHz	12	61		
				100MHz	11	60		
				80MHz	9.0	58		
				60MHz	7.4	56		
				40MHz	5.6	54		
				20MHz	3.9	53		
8MHz	2.9	52						
4MHz	2.6	51						

**Table 12-6. Typical and maximum current consumption in Sleep operation(PLL), when PCLK0 = PCLK1 = PCLK2 = HCLK**

Parameter	Symbol	Pin name	Conditions	Frequency*5	Value		Unit	Remarks		
					Typ*1	Max*2				
Power supply current	I <sub>ccs</sub>	VCC	Sleep operation (PLL)	72MHz	22	71	Ma	*3 When all peripheral clocks are ON		
				60MHz	19	68				
				48MHz	16	64				
				36MHz	12	61				
				24MHz	9.0	58				
				12MHz	5.8	55				
				8MHz	4.6	54				
				4MHz	3.6	52			Ma	*3 When all peripheral clocks are OFF
				72MHz	9.5	58				
				60MHz	8.3	57				
				48MHz	7.1	56				
				36MHz	5.8	55				
				24MHz	4.6	53				
				12MHz	3.5	52				
				8MHz	3.0	52				
				4MHz	2.7	51				

\*1: T<sub>A</sub> = +25°C, V<sub>CC</sub> = 3.3V

\*2: T<sub>j</sub> = +125°C, V<sub>CC</sub> = 5.5V

\*3: When all ports are fixed.

\*4: Frequency is a value of HCLK. PCLK0 = PCLK1 = PCLK2 = HCLK/2

\*5: Frequency is a value of HCLK. PCLK0 = PCLK1 = PCLK2 = HCLK

**Table 12-7. Typical and maximum current consumption in Sleep operation (other than PLL), when PCLK0 = PCLK1 = PCLK2 = HCLK/2**

Parameter	Symbol	Pin name	Conditions	Frequency*4	Value		Unit	Remarks
					Typ*1	Max*2		
Power supply current	I <sub>CCS</sub>	VCC	Sleep operation (built-in high-speed CR)	4MHz	1.5	49	Ma	*3 When all peripheral clocks are ON
					1.0	49	Ma	*3 When all peripheral clocks are OFF
			Sleep operation (sub oscillation)	32kHz	0.59	48	Ma	*3 When all peripheral clocks are ON
					0.51	48	Ma	*3 When all peripheral clocks are OFF
			Sleep operation (built-in low-speed CR)	100kHz	0.61	48	Ma	*3 When all peripheral clocks are ON
					0.53	48	Ma	*3 When all peripheral clocks are OFF

\*1: T<sub>A</sub> = +25°C, V<sub>CC</sub> = 3.3V

\*2: T<sub>j</sub> = +125°C, V<sub>CC</sub> = 5.5V

\*3: When all ports are fixed.

\*4: Frequency is a value of HCLK. PCLK0 = PCLK1 = PCLK2 = HCLK/2

**Table 12-8. Typical and maximum current consumption in STOP mode, TIMER mode and RTC mode**

Parameter	Symbol	Pin name	Conditions	Frequency	Value		Unit	Remarks
					Typ*1	Max*2		
Power supply current	I <sub>CC</sub> H	V <sub>CC</sub>	STOP mode	-	0.33	1.8	Ma	*3 *4 T <sub>A</sub> = +25°C
					-	15	Ma	*3 *4 T <sub>A</sub> = +85°C
					-	22	Ma	*3 *4 T <sub>A</sub> = +105°C
	I <sub>CC</sub> T		TIMER mode (built-in high-speed CR)	4MHz	0.70	2.2	Ma	*3 *4 T <sub>A</sub> = +25°C
					-	16	Ma	*3 *4 T <sub>A</sub> = +85°C
					-	22	Ma	*3 *4 T <sub>A</sub> = +105°C
			TIMER mode (sub oscillation)	32kHz	0.33	1.8	Ma	*3 *4 T <sub>A</sub> = +25°C
					-	15	Ma	*3 *4 T <sub>A</sub> = +85°C
					-	22	Ma	*3 *4 T <sub>A</sub> = +105°C
			TIMER mode (built-in low-speed CR)	100kHz	0.34	1.8	Ma	*3 *4 T <sub>A</sub> = +25°C
					-	15	Ma	*3 *4 T <sub>A</sub> = +85°C
					-	22	Ma	*3 *4 T <sub>A</sub> = +105°C
	I <sub>CC</sub> R		RTC mode (sub oscillation)	32kHz	0.33	1.8	Ma	*3 *4 T <sub>A</sub> = +25°C
					-	15	Ma	*3 *4 T <sub>A</sub> = +85°C
					-	22	Ma	*3 *4 T <sub>A</sub> = +105°C

\*1: V<sub>CC</sub> = 3.3V

\*2: V<sub>CC</sub> = 5.5V

\*3: When all ports are fixed.

\*4: When LVD is OFF

**Table 12-9. Typical and maximum current consumption in Deep Standby STOP mode, Deep Standby RTC mode and VBAT**

Parameter	Symbol	Pin name	Conditions	Frequency	Value		Unit	Remarks
					Typ*1	Max*2		
Power supply current	I <sub>CCHD</sub>	VCC	Deep standby STOP mode (When RAM is OFF)	-	29	140	Ma	<sup>*3, *4</sup> T <sub>A</sub> = +25°C
					-	644	Ma	<sup>*3, *4</sup> T <sub>A</sub> = +85°C
					-	1011	Ma	<sup>*3, *4</sup> T <sub>A</sub> = +105°C
			Deep standby STOP mode (When RAM is ON)		48	273	Ma	<sup>*3, *4</sup> T <sub>A</sub> = +25°C
					-	2676	Ma	<sup>*3, *4</sup> T <sub>A</sub> = +85°C
					-	4162	Ma	<sup>*3, *4</sup> T <sub>A</sub> = +105°C
	I <sub>CCRD</sub>	VCC	Deep standby RTC mode (When RAM is OFF)	32kHz	29	140	Ma	<sup>*3, *4</sup> T <sub>A</sub> = +25°C
					-	644	Ma	<sup>*3, *4</sup> T <sub>A</sub> = +85°C
					-	1011	Ma	<sup>*3, *4</sup> T <sub>A</sub> = +105°C
			Deep standby RTC mode (When RAM is ON)		48	273	Ma	<sup>*3, *4</sup> T <sub>A</sub> = +25°C
					-	2676	Ma	<sup>*3, *4</sup> T <sub>A</sub> = +85°C
					-	4162	Ma	<sup>*3, *4</sup> T <sub>A</sub> = +105°C
I <sub>CCVBAT</sub>	VBAT	RTC stop*6	-	0.015	0.29	Ma	<sup>*3, *4, *5</sup> T <sub>A</sub> = +25°C	
				-	5.77	Ma	<sup>*3, *4, *5</sup> T <sub>A</sub> = +85°C	
				-	10.6	Ma	<sup>*3, *4, *5</sup> T <sub>A</sub> = +105°C	
		RTC operation*6		1.53	22.6	Ma	<sup>*3, *4</sup> T <sub>A</sub> = +25°C	
				-	35.2	Ma	<sup>*3, *4</sup> T <sub>A</sub> = +85°C	
				-	41.8	Ma	<sup>*3, *4</sup> T <sub>A</sub> = +105°C	

\*1: V<sub>CC</sub> = 3.3V

\*2: V<sub>CC</sub> = 5.5V

\*3: When all ports are fixed.

\*4: When LVD is OFF

\*5: When sub oscillation is OFF

\*6: In the case of setting RTC after VCC power on

**Table 12-10. Typical and maximum current consumption in Low-voltage detection circuit, Main flash memory write/erase**

Parameter	Symbol	Pin name	Conditions	Value			Unit	Remarks
				Min	Typ	Max		
Low-voltage detection circuit (LVD) power supply current	$I_{CC\text{LVD}}$	VCC	At operation	-	4	7	Ma	For occurrence of interrupt
Main flash memory write/erase current	$I_{CC\text{FLASH}}$		At Write/Erase	-	13.4	15.9	Ma	
Work flash memory write/erase current	$I_{CC\text{WFLASH}}$		At Write/Erase	-	11.5	13.6	Ma	

**Peripheral current dissipation**

Clock system	Peripheral	Unit	Frequency (MHz)			Unit	Remarks
			40	80	160		
HCLK	GPIO	All ports	0.22	0.43	0.85	Ma	
	DMAC	-	0.74	1.48	2.88		
	DSTC	-	0.32	0.61	1.17		
	External bus I/F	-	0.14	0.27	0.55		
	SD card I/F	-	0.93	1.81	3.63		
PCLK1	Base timer	4ch.	0.16	0.34	0.66	Ma	
	Multi-functional timer/PPG	1unit/4ch.	0.55	1.09	2.17		
	Quadrature position/Revolution counter	1unit	0.04	0.09	0.17		
	A/DC	1unit	0.20	0.39	0.78		
PCLK2	Muli-function serial	1ch.	0.31	0.62	-	Ma	

**12.3.2 Pin Characteristics**
 $(V_{CC} = AV_{CC} = 2.7V \text{ to } 5.5V, V_{SS} = AV_{SS} = 0V)$ 

Parameter	Symbol	Pin name	Conditions	Value			Unit	Remarks
				Min	Typ	Max		
“H” level input voltage (hysteresis input)	$V_{IHS}$	CMOS hysteresis input pin, MD0, MD1	-	$V_{CC} \times 0.8$	-	$V_{CC} + 0.3$	V	
		5V tolerant input pin	-	$V_{CC} \times 0.8$	-	$V_{SS} + 5.5$	V	
		Input pin doubled as I <sup>2</sup> C Fm+	-	$V_{CC} \times 0.7$	-	$V_{SS} + 5.5$	V	
“L” level input voltage (hysteresis input)	$V_{ILS}$	CMOS hysteresis input pin, MD0, MD1	-	$V_{SS} - 0.3$	-	$V_{CC} \times 0.2$	V	
		5V tolerant input pin	-	$V_{SS} - 0.3$	-	$V_{CC} \times 0.2$	V	
		Input pin doubled as I <sup>2</sup> C Fm+	-	$V_{SS}$	-	$V_{CC} \times 0.3$	V	
“H” level output voltage	$V_{OH}$	4Ma type	$V_{CC} \geq 4.5 V,$ $I_{OH} = - 4Ma$	$V_{CC} - 0.5$	-	$V_{CC}$	V	
			$V_{CC} < 4.5 V,$ $I_{OH} = - 2Ma$					
		8Ma type	$V_{CC} \geq 4.5 V,$ $I_{OH} = - 8Ma$	$V_{CC} - 0.5$	-	$V_{CC}$	V	
			$V_{CC} < 4.5 V,$ $I_{OH} = - 4Ma$					
		12Ma type	$V_{CC} \geq 4.5 V,$ $I_{OH} = - 12Ma$	$V_{CC} - 0.5$	-	$V_{CC}$	V	
			$V_{CC} < 4.5 V,$ $I_{OH} = - 8Ma$					
		The pin doubled as I <sup>2</sup> C Fm+	$V_{CC} \geq 4.5 V,$ $I_{OH} = - 4Ma$	$V_{CC} - 0.5$	-	$V_{CC}$	V	At GPIO
			$V_{CC} < 4.5 V,$ $I_{OH} = - 3Ma$					

Parameter	Symbol	Pin name	Conditions	Value			Unit	Remarks		
				Min	Typ	Max				
“L” level output voltage	V <sub>OL</sub>	4Ma type	V <sub>CC</sub> ≥ 4.5 V, I <sub>OL</sub> = 4Ma	V <sub>SS</sub>	-	0.4	V			
			V <sub>CC</sub> < 4.5 V, I <sub>OL</sub> = 2Ma							
		8Ma type	V <sub>CC</sub> ≥ 4.5 V, I <sub>OH</sub> = 8Ma	V <sub>SS</sub>	-	0.4	V			
			V <sub>CC</sub> < 4.5 V, I <sub>OH</sub> = 4Ma							
		12Ma type	V <sub>CC</sub> ≥ 4.5 V, I <sub>OL</sub> = 12Ma	V <sub>SS</sub>	-	0.4	V			
			V <sub>CC</sub> < 4.5 V, I <sub>OL</sub> = 8Ma							
		The pin doubled as I <sup>2</sup> C Fm+	V <sub>CC</sub> ≥ 4.5 V, I <sub>OH</sub> = 4Ma	V <sub>SS</sub>	-	0.4	V	At GPIO		
			V <sub>CC</sub> < 4.5 V, I <sub>OH</sub> = 3Ma					At I <sup>2</sup> C Fm+		
			V <sub>CC</sub> ≤ 5.5 V, I <sub>OH</sub> = 20Ma							
		Input leak current	I <sub>IL</sub>	-	-	- 5	-	+ 5	Ma	
		Pull-up resistor value	R <sub>PU</sub>	Pull-up pin	V <sub>CC</sub> ≥ 4.5 V	25	50	100	Kω	
					V <sub>CC</sub> < 4.5 V	30	80	200		
Input capacitance	C <sub>IN</sub>	Other than VCC, VBAT, VSS, AVCC, AVSS, AVRH	-	-	5	15	Pf			

**12.4 AC Characteristics**

**12.4.1 Main Clock Input Characteristics**

(V<sub>CC</sub> = 2.7V to 5.5V, V<sub>SS</sub> = 0V)

Parameter	Symbol	Pin name	Conditions	Value		Unit	Remarks	
				Min	Max			
Input frequency	F <sub>CH</sub>	X0, X1	V <sub>CC</sub> ≥ 4.5V	4	48	MHz	When crystal oscillator is connected	
			V <sub>CC</sub> < 4.5V	4	20			
			V <sub>CC</sub> ≥ 4.5V	4	48	MHz	When using external clock	
			V <sub>CC</sub> < 4.5V	4	20			
Input clock cycle	t <sub>CY LH</sub>		V <sub>CC</sub> ≥ 4.5V	20.83	250	ns	When using external clock	
			V <sub>CC</sub> < 4.5V	50	250			
Input clock pulse width	-			PWH/Tcylh, PWL/Tcylh	45	55	%	When using external clock
Input clock rising time and falling time	t <sub>CF</sub> , t <sub>CR</sub>			-	-	5	ns	When using external clock
Internal operating clock*1 frequency	F <sub>CC</sub>	-	-	-	160	MHz	Base clock (HCLK/FCLK)	
	F <sub>CP0</sub>	-	-	-	80	MHz	APB0 bus clock*2	
	F <sub>CP1</sub>	-	-	-	160	MHz	APB1 bus clock*2	
	F <sub>CP2</sub>	-	-	-	80	MHz	APB2 bus clock*2	
Internal operating clock*1 cycle time	t <sub>CYCC</sub>	-	-	6.25	-	ns	Base clock (HCLK/FCLK)	
	t <sub>CYCP0</sub>	-	-	12.5	-	ns	APB0 bus clock*2	
	t <sub>CYCP1</sub>	-	-	6.25	-	ns	APB1 bus clock*2	
	t <sub>CYCP2</sub>	-	-	12.5	-	ns	APB2 bus clock*2	

\*1: For more information about each internal operating clock, see “Chapter: Clock” in “FM4 Family Peripheral Manual”.

\*2: For about each APB bus which each peripheral is connected to, see “Block Diagram” in this datasheet.

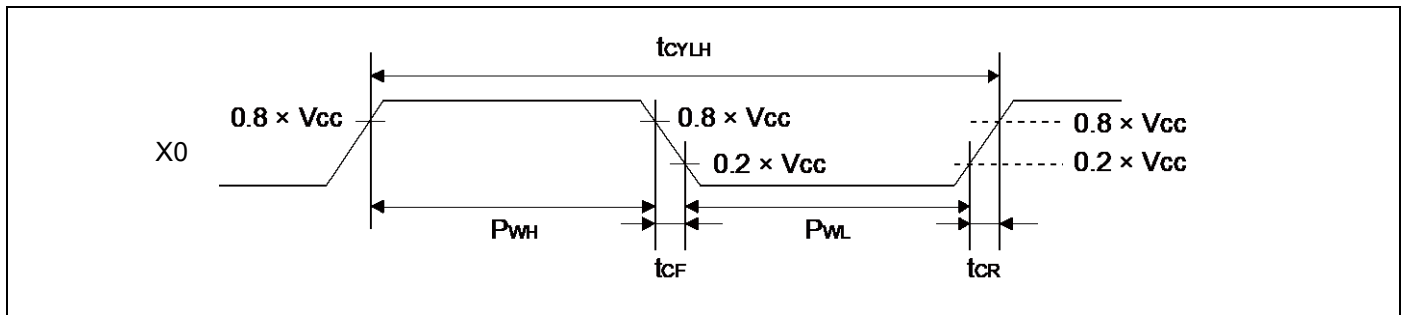

**12.4.2 Sub Clock Input Characteristics**

 (V<sub>BAT</sub> = 2.7V to 5.5V, V<sub>SS</sub> = 0V)

Parameter	Symbol	Pin name	Conditions	Value			Unit	Remarks
				Min	Typ	Max		
Input frequency	1/ t <sub>CYLL</sub>	X0A, X1A	-	-	32.768	-	kHz	When crystal oscillator is connected
			-	32	-	100	kHz	When using external clock
Input clock cycle	t <sub>CYLL</sub>		-	10	-	31.25	μs	When using external clock
Input clock pulse width	-		P <sub>WH</sub> /t <sub>CYLL</sub> , P <sub>WL</sub> /t <sub>CYLL</sub>	45	-	55	%	When using external clock

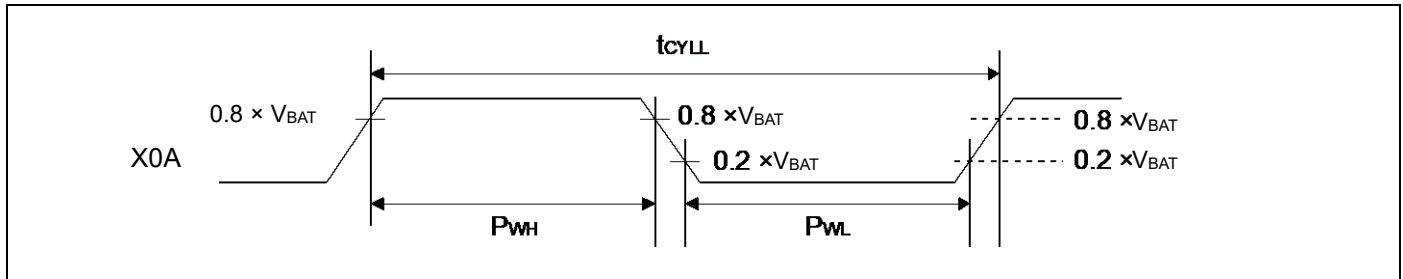
**12.4.3 Built-in CR Oscillation Characteristics**
**Built-in High-speed CR**

 (V<sub>CC</sub> = 2.7V to 5.5V, V<sub>SS</sub> = 0V)

Parameter	Symbol	Conditions	Value			Unit	Remarks
			Min	Typ	Max		
Clock frequency	F <sub>CRH</sub>	T <sub>j</sub> = -20°C to + 105°C	3.92	4	4.08	MHz	When trimming* <sup>1</sup>
		T <sub>j</sub> = - 40°C to + 125°C	3.88	4	4.12		
Clock frequency	F <sub>CRH</sub>	T <sub>j</sub> = - 40°C to + 125°C	3	4	5		When not trimming
Frequency stabilization time	t <sub>CRWT</sub>	-	-	-	30	μs	* <sup>2</sup>

\*1: In the case of using the values in CR trimming area of Flash memory at shipment for frequency/temperature trimming.

\*2: This is the time to stabilize the frequency of high-speed CR clock after setting trimming value. This period is able to use high-speed CR clock as source clock.

**Built-in Low-speed CR**

 (V<sub>CC</sub> = 2.7V to 5.5V, V<sub>SS</sub> = 0V)

Parameter	Symbol	Condition	Value			Unit	Remarks
			Min	Typ	Max		
Clock frequency	F <sub>CRL</sub>	-	50	100	150	kHz	

**12.4.4 Operating Conditions of Main PLL (In the case of using main clock for input clock of PLL)**
*(V<sub>CC</sub> = 2.7V to 5.5V, V<sub>SS</sub> = 0V)*

Parameter	Symbol	Value			Unit	Remarks
		Min	Typ	Max		
PLL oscillation stabilization wait time* <sup>1</sup> (LOCK UP time)	t <sub>LOCK</sub>	200	-	-	μs	
PLL input clock frequency	F <sub>PLL</sub>	4	-	16	MHz	
PLL multiplication rate	-	13	-	80	multiplier	
PLL macro oscillation clock frequency	F <sub>PLLO</sub>	200	-	320	MHz	
Main PLL clock frequency* <sup>2</sup>	F <sub>CLKPLL</sub>	-	-	160	MHz	

\*1: Time from when the PLL starts operating until the oscillation stabilizes.

\*2: For more information about Main PLL clock (CLKPLL), see “Chapter: Clock” in “FM4 Family Peripheral Manual”.

**12.4.5 Operating Conditions of Main PLL (In the case of using built-in high-speed CR clock for input clock of main PLL)**
*(V<sub>CC</sub> = 2.7V to 5.5V, V<sub>SS</sub> = 0V)*

Parameter	Symbol	Value			Unit	Remarks
		Min	Typ	Max		
PLL oscillation stabilization wait time* <sup>1</sup> (LOCK UP time)	t <sub>LOCK</sub>	200	-	-	μs	
PLL input clock frequency	F <sub>PLL</sub>	3.8	4	4.2	MHz	
PLL multiplication rate	-	50	-	75	multiplier	
PLL macro oscillation clock frequency	F <sub>PLLO</sub>	190	-	320	MHz	
Main PLL clock frequency* <sup>2</sup>	F <sub>CLKPLL</sub>	-	-	160	MHz	

\*1: Time from when the PLL starts operating until the oscillation stabilizes.

\*2: For more information about Main PLL clock (CLKPLL), see “Chapter: Clock” in “FM4 Family Peripheral Manual”.

**Note:**

- Make sure to input to the main PLL source clock, the high-speed CR clock (CLKHC) that the frequency and temperature has been trimmed.

**12.4.6 Reset Input Characteristics**
*(V<sub>CC</sub> = 2.7V to 5.5V, V<sub>SS</sub> = 0V)*

Parameter	Symbol	Pin name	Condition	Value		Unit	Remarks
				Min	Max		
Reset input time	t <sub>INITX</sub>	INITX	-	500	-	ns	

**12.4.7 Power-on Reset Timing**

(V<sub>SS</sub> = 0V, T<sub>A</sub> = -40°C to +85°C)

Parameter	Symbol	Pin Name	Conditions	Value			Unit	Remarks
				Min	Typ	Max		
Power supply shut down time	t <sub>OFF</sub>	VCC	-	50	-	-	ms	*1
Power ramp rate	Dv/dt		V <sub>CC</sub> : 0.2V to 2.70V	1.3	-	1000	MV/μs	*2
Time until releasing Power-on reset	t <sub>PRT</sub>		-	0.33	-	0.60	ms	

\*1: V<sub>CC</sub> must be held below 0.2V for a minimum period of t<sub>OFF</sub>. Improper initialization may occur if this condition is not met.

\*2: This Dv/dt characteristic is applied at the power-on of cold start (t<sub>OFF</sub>>50ms).

**Note:**

- If T<sub>off</sub> cannot be satisfied designs must assert external reset(INITX) at power-up and at any brownout event per 12. 4. 6.

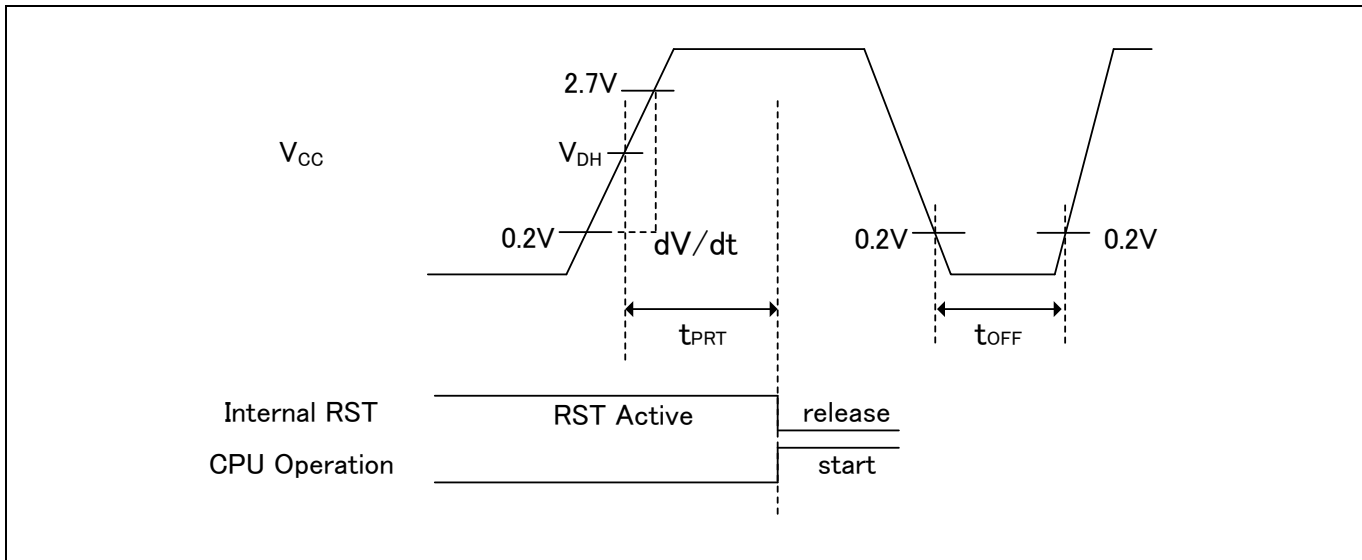

**Glossary:**

□ V<sub>DH</sub>: detection voltage of Low Voltage detection reset. See “12.7. Low-Voltage Detection Characteristics”.

**12.4.8 GPIO Output Characteristics**

(V<sub>CC</sub> = 2.7V to 5.5V, V<sub>SS</sub> = 0V)

Parameter	Symbol	Pin name	Conditions	Value		Unit
				Min	Max	
Output frequency	t <sub>PCYCLE</sub>	Pxx*	V <sub>CC</sub> ≥ 4.5 V	-	50	MHz
			V <sub>CC</sub> < 4.5 V	-	32	MHz

\*: GPIO is a target.

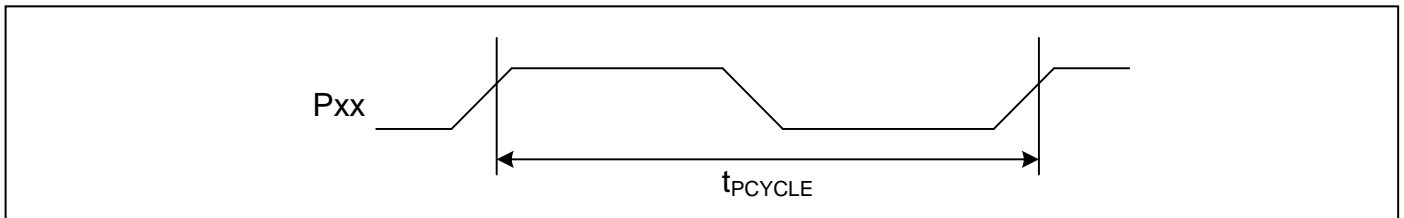

**12.4.9 External Bus Timing**
**External bus clock output characteristics**

 (V<sub>CC</sub> = 2.7V to 5.5V, V<sub>SS</sub> = 0V)

Parameter	Symbol	Pin name	Conditions	Value		Unit
				Min	Max	
Output frequency	t <sub>CYCLE</sub>	MCLKOUT*1	V <sub>CC</sub> ≥ 4.5 V	-	50*2	MHz
			V <sub>CC</sub> < 4.5 V	-	32*3	MHz

\*1: The external bus clock (MCLKOUT) is a divided clock of HCLK.

For more information about setting of clock divider, see “Chapter: External Bus Interface” in “FM4 Family Peripheral Manual”.

\*2: Generate MCLKOUT at setting more than 4 division when the AHB bus clock exceeds 100MHz.

\*3: Generate MCLKOUT at setting more than 4 division when the AHB bus clock exceeds 64MHz.

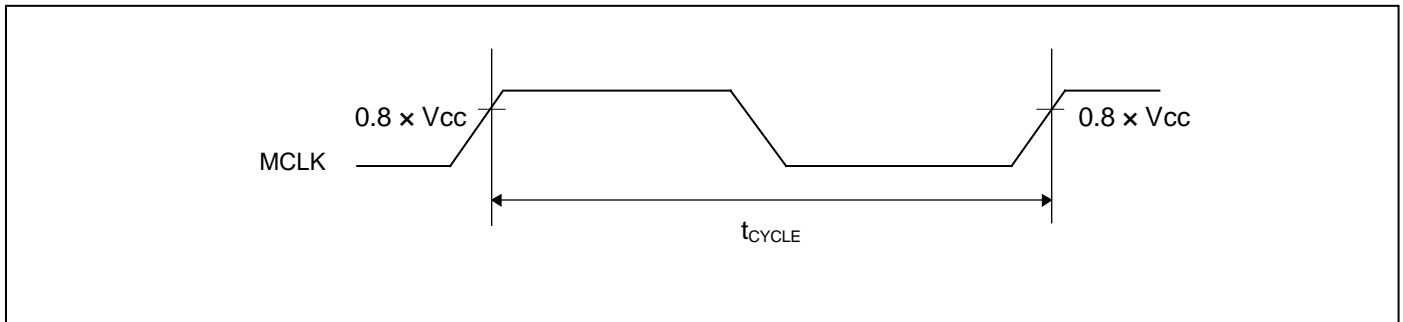
**External bus signal input/output characteristics**

 (V<sub>CC</sub> = 2.7V to 5.5V, V<sub>SS</sub> = 0V)

Parameter	Symbol	Conditions	Value	Unit	Remarks
Signal input characteristics	V <sub>IH</sub>	-	0.8 × V <sub>CC</sub>	V	
	V <sub>IL</sub>		0.2 × V <sub>CC</sub>	V	
Signal output characteristics	V <sub>OH</sub>		0.8 × V <sub>CC</sub>	V	
	V <sub>OL</sub>		0.2 × V <sub>CC</sub>	V	

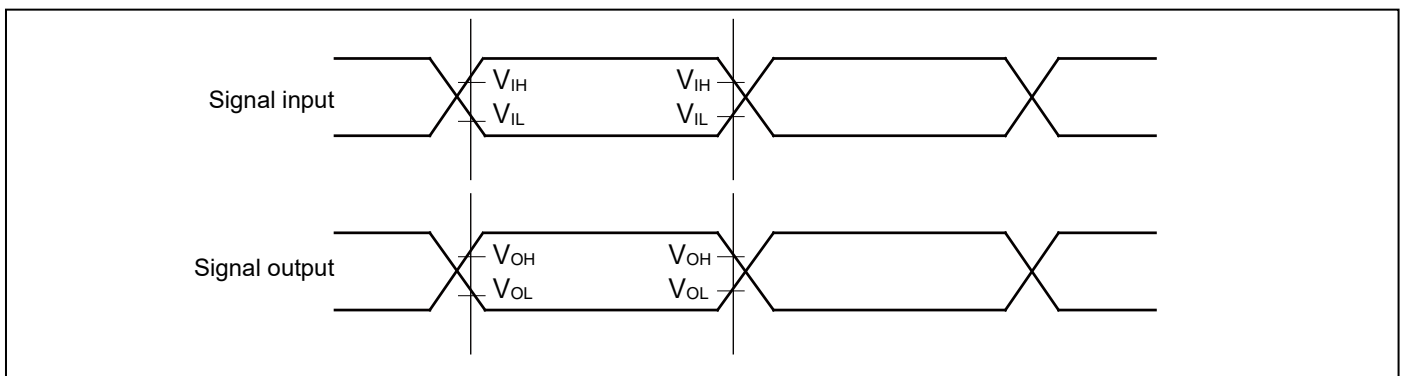

**Separate Bus Access Asynchronous SRAM Mode**

 (V<sub>CC</sub> = 2.7V to 5.5V, V<sub>SS</sub> = 0V)

Parameter	Symbol	Pin name	Conditions	Value		Unit
				Min	Max	
MOEX Minimum pulse width	t <sub>OEW</sub>	MOEX	V <sub>CC</sub> ≥ 4.5V	MCLK×n-3	-	ns
			V <sub>CC</sub> < 4.5V			
MCSX↓→Address output delay time	t <sub>CSL-AV</sub>	MCSX[7:0], MAD[24:0]	V <sub>CC</sub> ≥ 4.5V	-9	+9	ns
			V <sub>CC</sub> < 4.5V	-12	+12	
MOEX↑→Address hold time	t <sub>OEH-AX</sub>	MOEX, MAD[24:0]	V <sub>CC</sub> ≥ 4.5V	0	MCLK×m+9	ns
			V <sub>CC</sub> < 4.5V		MCLK×m+12	
MCSX↓→ MOEX↓ delay time	t <sub>CSL-OEL</sub>	MOEX, MCSX[7:0]	V <sub>CC</sub> ≥ 4.5V	MCLK×m-9	MCLK×m+9	ns
			V <sub>CC</sub> < 4.5V	MCLK×m-12	MCLK×m+12	
MOEX↑→ MCSX↑ time	t <sub>OEH-CSH</sub>	MCSX[7:0]	V <sub>CC</sub> ≥ 4.5V	0	MCLK×m+9	ns
			V <sub>CC</sub> < 4.5V		MCLK×m+12	
MCSX↓→MDQM↓ delay time	t <sub>CSL-RDQML</sub>	MCSX, MDQM[1:0]	V <sub>CC</sub> ≥ 4.5V	MCLK×m-9	MCLK×m+9	ns
			V <sub>CC</sub> < 4.5V	MCLK×m-12	MCLK×m+12	
Data set up→MOEX↑ time	t <sub>DS-OE</sub>	MOEX, MADATA[15:0]	V <sub>CC</sub> ≥ 4.5V	20	-	ns
			V <sub>CC</sub> < 4.5V	38	-	
MOEX↑→ Data hold time	t <sub>DH-OE</sub>	MOEX, MADATA[15:0]	V <sub>CC</sub> ≥ 4.5V	0	-	ns
			V <sub>CC</sub> < 4.5V			
MWEX Minimum pulse width	t <sub>WEW</sub>	MWEX	V <sub>CC</sub> ≥ 4.5V	MCLK×n-3	-	ns
			V <sub>CC</sub> < 4.5V			
MWEX↑→Address output delay time	t <sub>WEH-AX</sub>	MWEX, MAD[24:0]	V <sub>CC</sub> ≥ 4.5V	0	MCLK×m+9	ns
			V <sub>CC</sub> < 4.5V		MCLK×m+12	
MCSX↓→MWEX↓ delay time	t <sub>CSL-WEL</sub>	MWEX, MCSX[7:0]	V <sub>CC</sub> ≥ 4.5V	MCLK×n-9	MCLK×n+9	ns
			V <sub>CC</sub> < 4.5V	MCLK×n-12	MCLK×n+12	
MWEX↑→MCSX↑ delay time	t <sub>WEH-CSH</sub>	MCSX[7:0]	V <sub>CC</sub> ≥ 4.5V	0	MCLK×m+9	ns
			V <sub>CC</sub> < 4.5V		MCLK×m+12	
MCSX↓→MDQM↓ delay time	t <sub>CSL-WDQML</sub>	MCSX, MDQM[1:0]	V <sub>CC</sub> ≥ 4.5V	MCLK×n-9	MCLK×n+9	ns
			V <sub>CC</sub> < 4.5V	MCLK×n-12	MCLK×n+12	
MCSX↓→ Data output time	t <sub>CSL-DX</sub>	MCSX, MADATA[15:0]	V <sub>CC</sub> ≥ 4.5V	MCLK-9	MCLK+9	ns
			V <sub>CC</sub> < 4.5V	MCLK-12	MCLK+12	
MWEX↑→ Data hold time	t <sub>WEH-DX</sub>	MWEX, MADATA[15:0]	V <sub>CC</sub> ≥ 4.5V	0	MCLK×m+9	ns
			V <sub>CC</sub> < 4.5V		MCLK×m+12	

**Note:**

- When the external load capacitance C<sub>L</sub> = 30Pf (m = 0 to 15, n = 1 to 16)

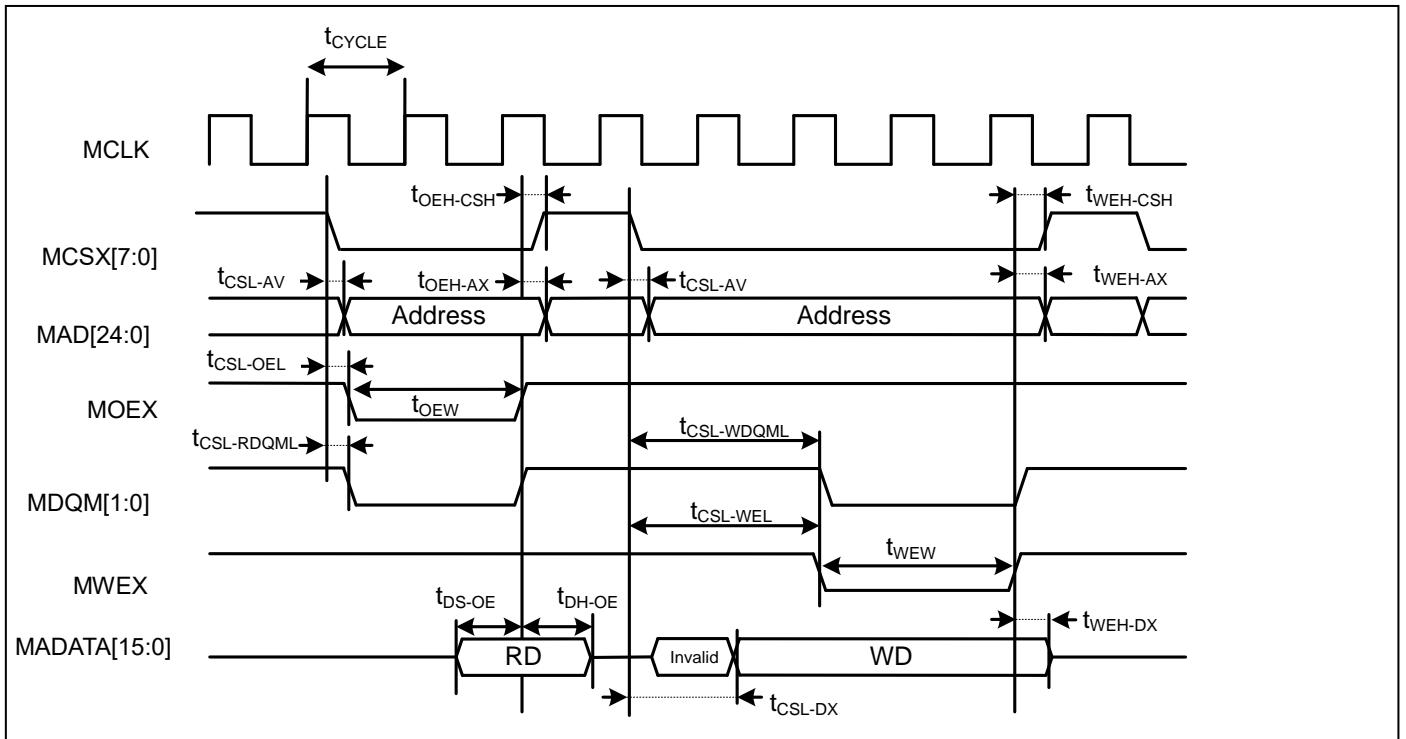

Separate Bus Access Synchronous SRAM Mode

(V<sub>CC</sub> = 2.7V to 5.5V, V<sub>SS</sub> = 0V)

Parameter	Symbol	Pin name	Conditions	Value		Unit
				Min	Max	
Address delay time	t <sub>AV</sub>	MCLK, MAD[24:0]	V <sub>CC</sub> ≥ 4.5V	1	9	ns
			V <sub>CC</sub> < 4.5V		12	
MCSX delay time	t <sub>CSL</sub>	MCLK, MCSX[7:0]	V <sub>CC</sub> ≥ 4.5V	1	9	ns
			V <sub>CC</sub> < 4.5V		12	
	t <sub>CSH</sub>		V <sub>CC</sub> ≥ 4.5V	1	9	ns
			V <sub>CC</sub> < 4.5V		12	
MOEX delay time	t <sub>REL</sub>	MCLK, MOEX	V <sub>CC</sub> ≥ 4.5V	1	9	ns
			V <sub>CC</sub> < 4.5V		12	
	t <sub>REH</sub>		V <sub>CC</sub> ≥ 4.5V	1	9	ns
			V <sub>CC</sub> < 4.5V		12	
Data set up →MCLK↑ time	t <sub>DS</sub>	MCLK, MADATA[15:0]	V <sub>CC</sub> ≥ 4.5V	19	-	ns
			V <sub>CC</sub> < 4.5V	37		
MCLK↑→ Data hold time	t <sub>DH</sub>	MCLK, MADATA[15:0]	V <sub>CC</sub> ≥ 4.5V	0	-	ns
			V <sub>CC</sub> < 4.5V			
MWEX delay time	t <sub>WEL</sub>	MCLK, MWEX	V <sub>CC</sub> ≥ 4.5V	1	9	ns
			V <sub>CC</sub> < 4.5V		12	
	t <sub>WEH</sub>		V <sub>CC</sub> ≥ 4.5V	1	9	ns
			V <sub>CC</sub> < 4.5V		12	
MDQM[1:0] delay time	t <sub>DQML</sub>	MCLK, MDQM[1:0]	V <sub>CC</sub> ≥ 4.5V	1	9	ns
			V <sub>CC</sub> < 4.5V		12	
	t <sub>DQMH</sub>		V <sub>CC</sub> ≥ 4.5V	1	9	ns
			V <sub>CC</sub> < 4.5V		12	
MCLK↑→ Data output time	t <sub>ODS</sub>	MCLK, MADATA[15:0]	V <sub>CC</sub> ≥ 4.5V	MCLK+1	MCLK+18	ns
			V <sub>CC</sub> < 4.5V		MCLK+24	
MCLK↑→ Data hold time	t <sub>OD</sub>	MCLK, MADATA[15:0]	V <sub>CC</sub> ≥ 4.5V	1	18	ns
			V <sub>CC</sub> < 4.5V		24	

Note:

- When the external load capacitance C<sub>L</sub> = 30Pf

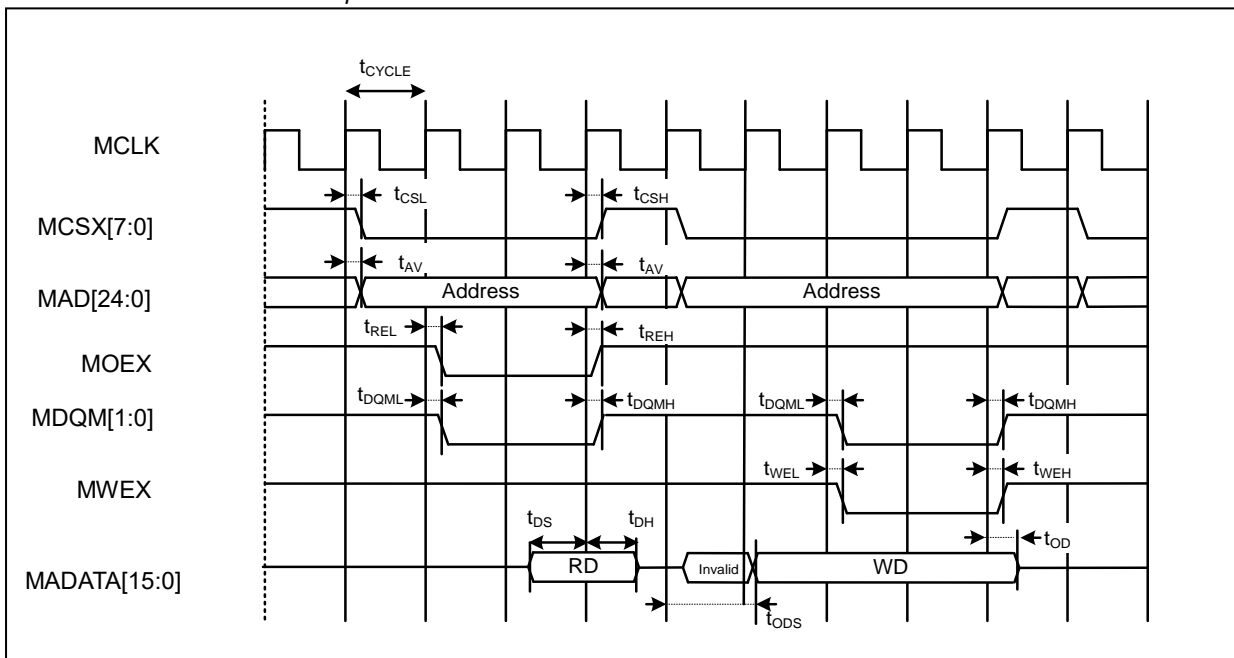

## Multiplexed Bus Access Asynchronous SRAM Mode

( $V_{CC} = 2.7V$  to  $5.5V$ ,  $V_{SS} = 0V$ )

Parameter	Symbol	Pin name	Conditions	Value		Unit
				Min	Max	
Multiplexed address delay time	$t_{ALE-CHMADV}$	MALE, MADATA[15:0]	$V_{CC} \geq 4.5V$	0	10	ns
			$V_{CC} < 4.5V$		20	
Multiplexed address hold time	$t_{CHMADH}$	MALE, MADATA[15:0]	$V_{CC} \geq 4.5V$	$MCLK \times n + 0$	$MCLK \times n + 10$	ns
			$V_{CC} < 4.5V$	$MCLK \times n + 0$	$MCLK \times n + 20$	

**Note:**

- When the external load capacitance  $C_L = 30Pf$  ( $m = 0$  to  $15$ ,  $n = 1$  to  $16$ )

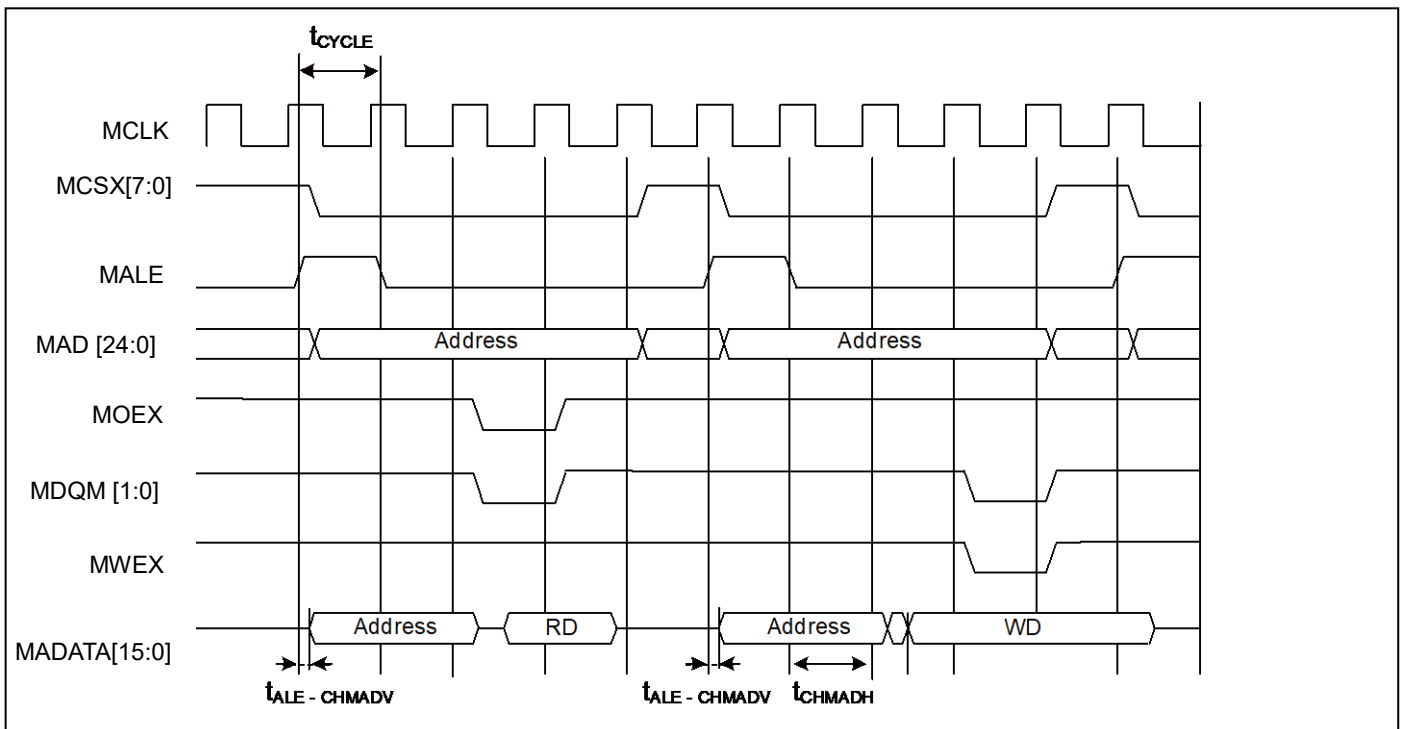

**Multiplexed Bus Access Synchronous SRAM Mode**

(V<sub>CC</sub> = 2.7V to 5.5V, V<sub>SS</sub> = 0V)

Parameter	Symbol	Pin name	Conditions	Value		Unit	Remarks
				Min	Max		
MALE delay time	t <sub>CHAL</sub>	MCLK, ALE	V <sub>CC</sub> ≥ 4.5V	1	9	ns	
			V <sub>CC</sub> < 4.5V		12		
	t <sub>CHAH</sub>		V <sub>CC</sub> ≥ 4.5V	1	9	ns	
			V <sub>CC</sub> < 4.5V		12		
MCLK↑→ Multiplexed address delay time	t <sub>CHMADV</sub>	MCLK, MADATA[15:0]	V <sub>CC</sub> ≥ 4.5V	1	t <sub>OD</sub>	ns	
			V <sub>CC</sub> < 4.5V				
MCLK↑→ Multiplexed data output time	t <sub>CHMADX</sub>		V <sub>CC</sub> ≥ 4.5V	1	t <sub>OD</sub>	ns	
			V <sub>CC</sub> < 4.5V				

**Note:**

- When the external load capacitance C<sub>L</sub> = 30Pf

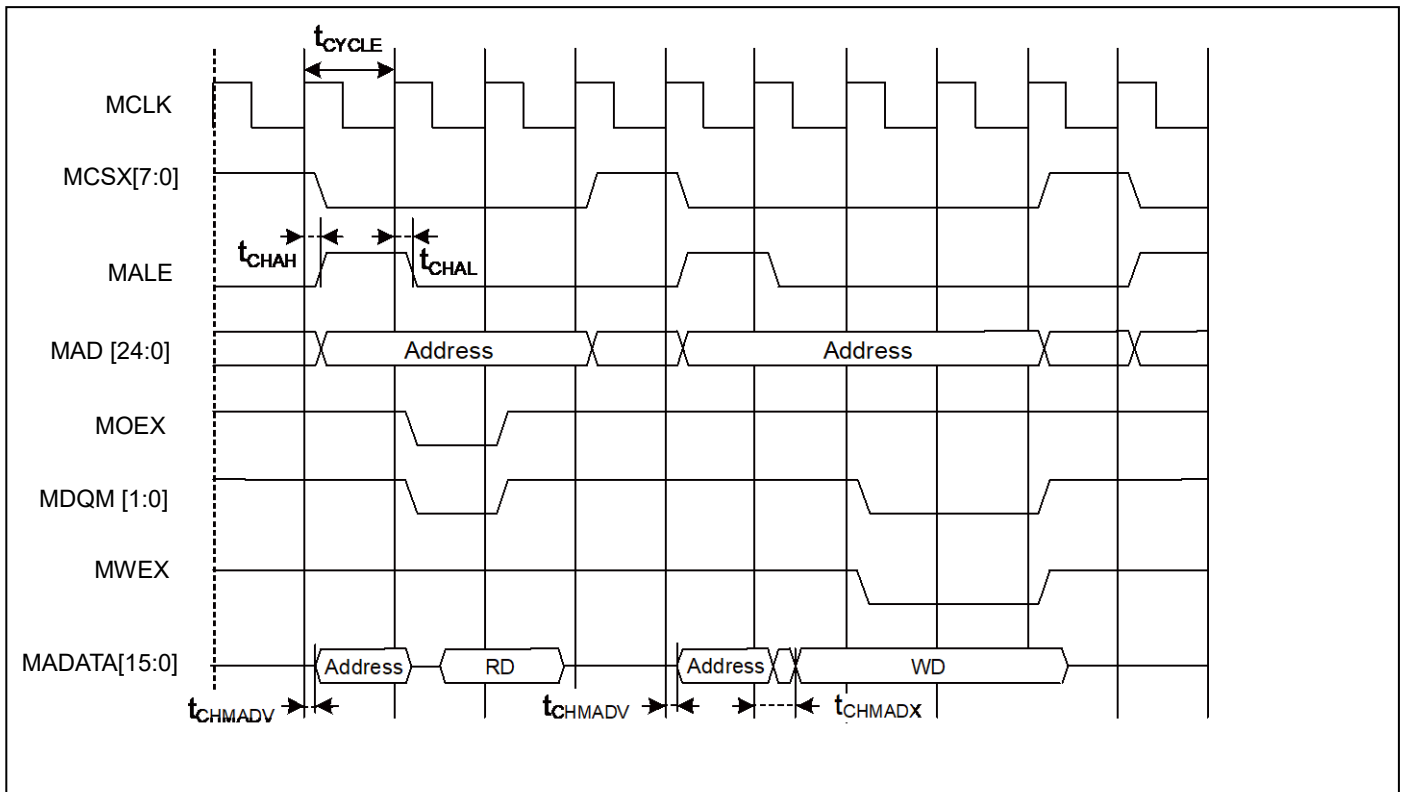

NAND Flash Mode

(V<sub>CC</sub> = 2.7V to 5.5V, V<sub>SS</sub> = 0V)

Parameter	Symbol	Pin name	Conditions	Value		Unit
				Min	Max	
MNREX Min pulse width	t <sub>NREW</sub>	MNREX	V <sub>CC</sub> ≥ 4.5V V <sub>CC</sub> < 4.5V	MCLK×n-3	-	ns
Data set up →MNREX↑ time	t <sub>DS-NRE</sub>	MNREX, MADATA[15:0]	V <sub>CC</sub> ≥ 4.5V V <sub>CC</sub> < 4.5V	20 38	-	ns
MNREX↑→ Data hold time	t <sub>DH-NRE</sub>	MNREX, MADATA[15:0]	V <sub>CC</sub> ≥ 4.5V V <sub>CC</sub> < 4.5V	0	-	ns
MNALE↑→ MNWEX delay time	t <sub>ALEH-NWEL</sub>	MNALE, MNWEX	V <sub>CC</sub> ≥ 4.5V V <sub>CC</sub> < 4.5V	MCLK×m-9 MCLK×m-12	MCLK×m+9 MCLK×m+12	ns
MNALE↓→ MNWEX delay time	t <sub>ALEL-NWEL</sub>	MNALE, MNWEX	V <sub>CC</sub> ≥ 4.5V V <sub>CC</sub> < 4.5V	MCLK×m-9 MCLK×m-12	MCLK×m+9 MCLK×m+12	ns
MNCLE↑→ MNWEX delay time	t <sub>CLEH-NWEL</sub>	MNCLE, MNWEX	V <sub>CC</sub> ≥ 4.5V V <sub>CC</sub> < 4.5V	MCLK×m-9 MCLK×m-12	MCLK×m+9 MCLK×m+12	ns
MNWE↑→ MNCLE delay time	t <sub>NWEH-CLEL</sub>	MNCLE, MNWEX	V <sub>CC</sub> ≥ 4.5V V <sub>CC</sub> < 4.5V	0	MCLK×m+9 MCLK×m+12	ns
MNWE Min pulse width	t <sub>NWEW</sub>	MNWE	V <sub>CC</sub> ≥ 4.5V V <sub>CC</sub> < 4.5V	MCLK×n-3	-	ns
MNWE↓→ Data output time	t <sub>NWEL-DV</sub>	MNWE, MADATA[15:0]	V <sub>CC</sub> ≥ 4.5V V <sub>CC</sub> < 4.5V	-9 -12	+9 +12	ns
MNWE↑→ Data hold time	t <sub>NWEH-DX</sub>	MNWE, MADATA[15:0]	V <sub>CC</sub> ≥ 4.5V V <sub>CC</sub> < 4.5V	0	MCLK×m+9 MCLK×m+12	ns

Note:

- When the external load capacitance C<sub>L</sub> = 30Pf (m = 0 to 15, n = 1 to 16)

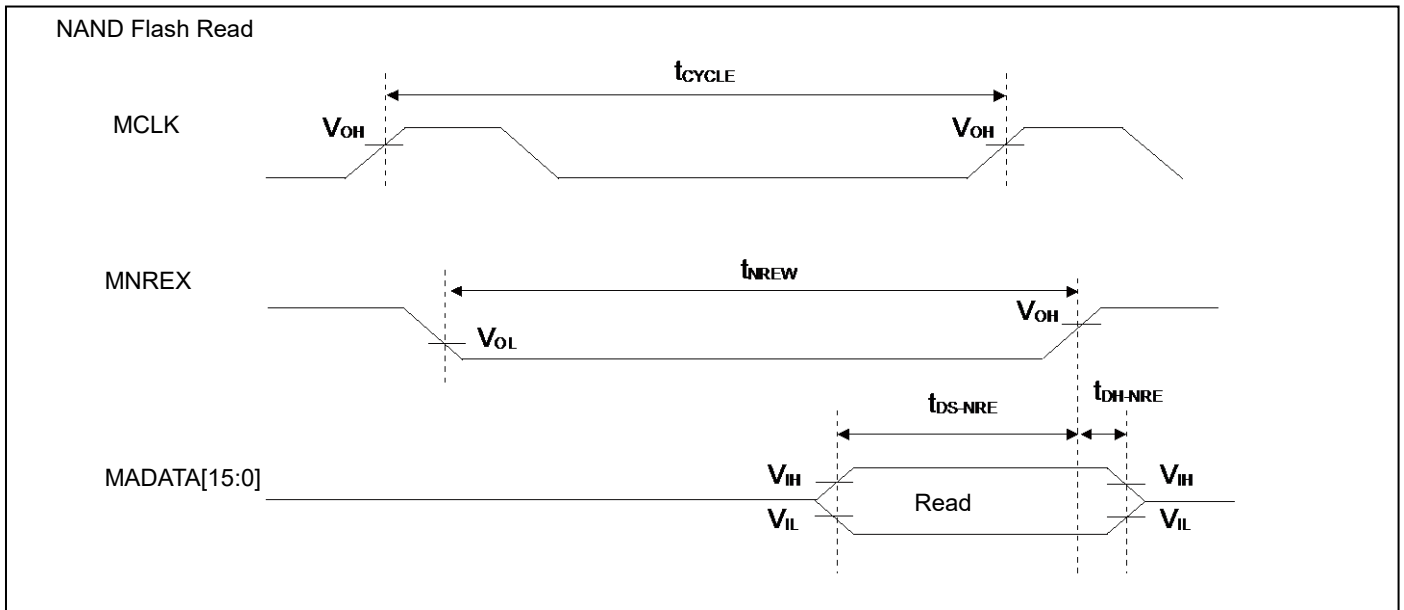

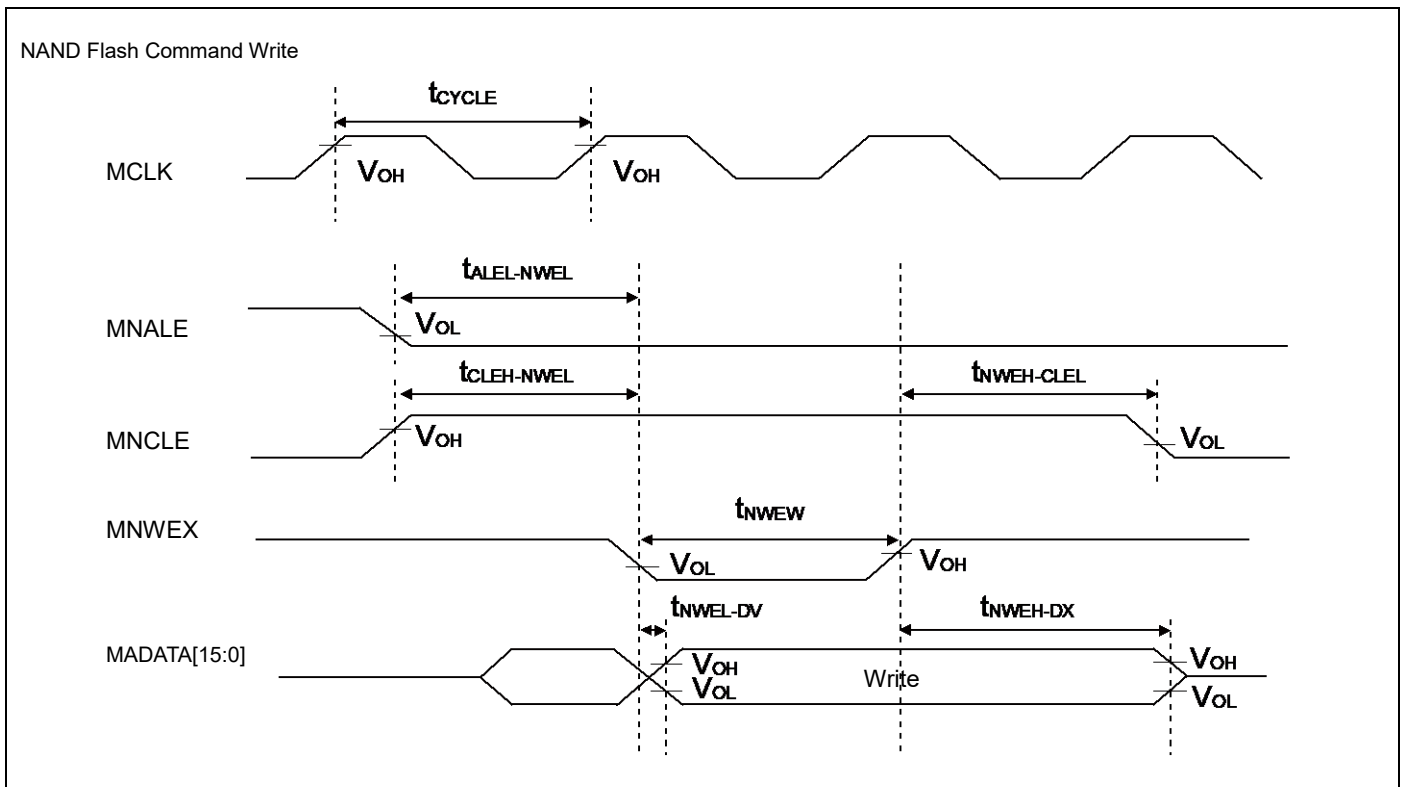
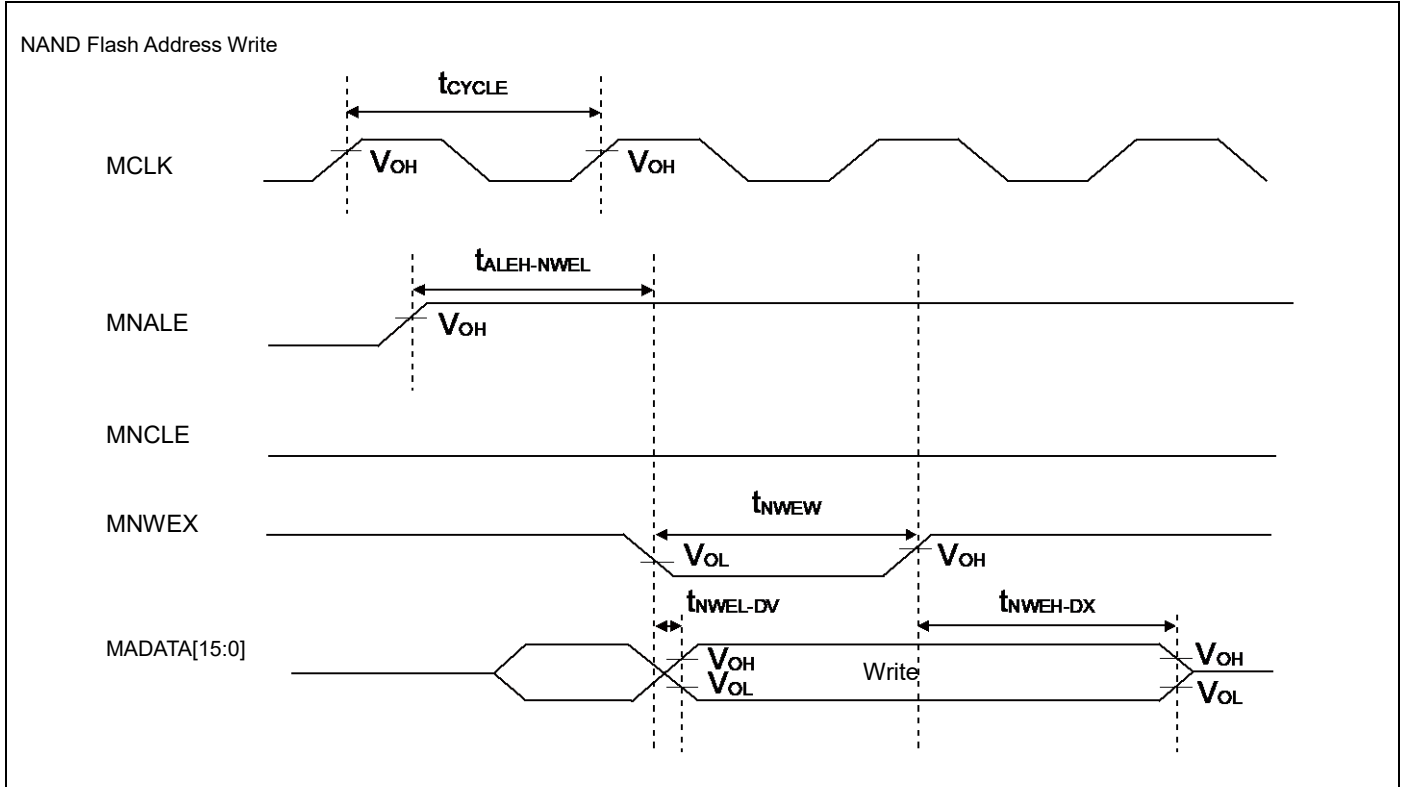

External Ready Input Timing

(V<sub>CC</sub> = 2.7V to 5.5V, V<sub>SS</sub> = 0V)

Parameter	Symbol	Pin name	Conditions	Value		Unit	Remarks
				Min	Max		
MCLK↑ MRDY input setup time	t <sub>RDYI</sub>	MCLK, MRDY	V <sub>CC</sub> ≥ 4.5V	19	-	ns	
			V <sub>CC</sub> < 4.5V	37			

When RDY is input

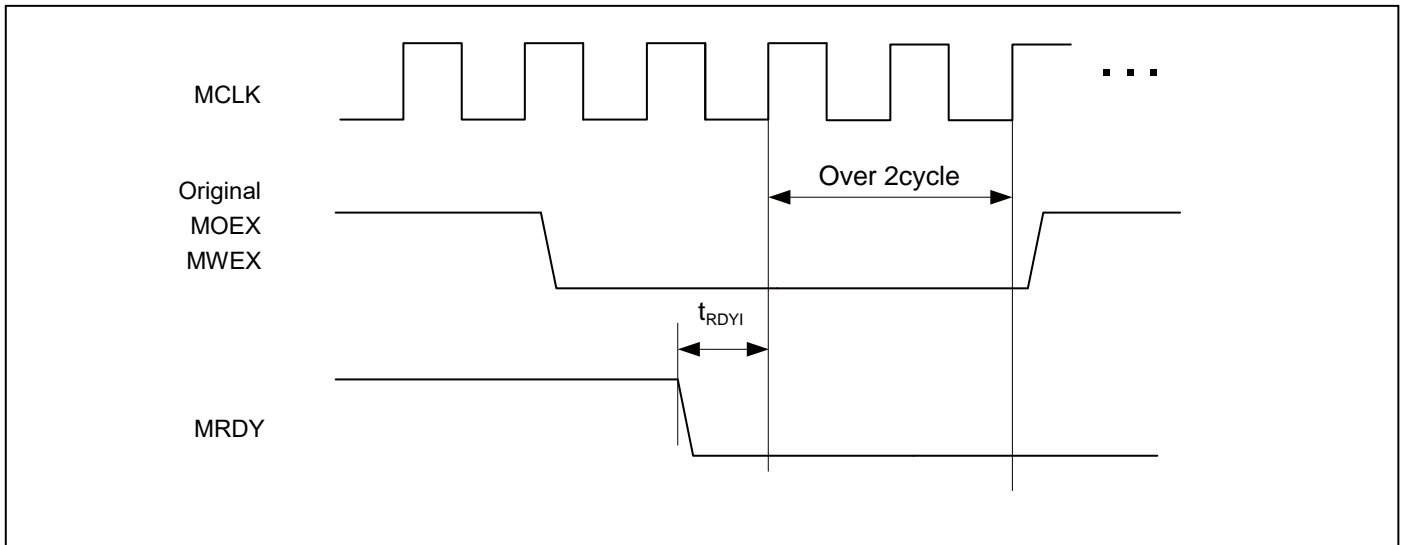

When RDY is released

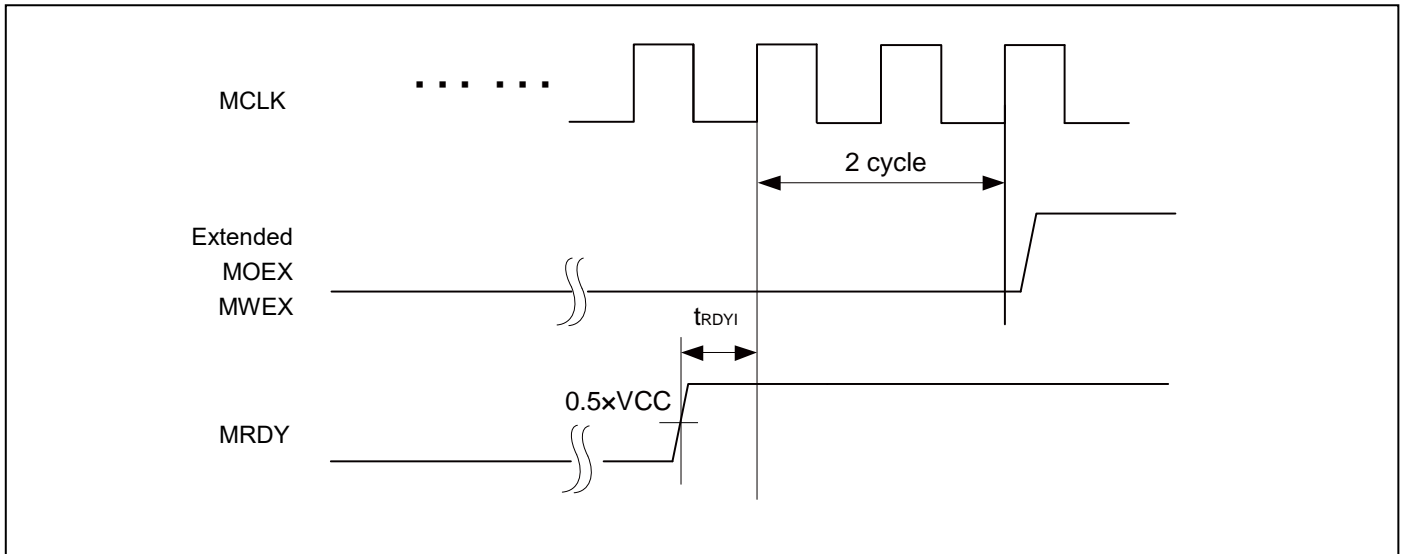

**SDRAM Mode**

 (V<sub>CC</sub> = 2.7V to 3.6V, V<sub>SS</sub> = 0V)

Parameter	Symbol	Pin name	Value		Unit
			Min	Max	
Output frequency	t <sub>CYCSD</sub>	MSDCLK	-	32	MHz
Address delay time	t <sub>AOSD</sub>	MSDCLK, MAD[15:0]	2	12	ns
MSDCLK↑→Data output delay time	t <sub>DOSD</sub>	MSDCLK, MADATA[31:0]	2	12	ns
MSDCLK↑→Data output Hi-Z time	t <sub>DOZSD</sub>	MSDCLK, MADATA[31:0]	2	20	ns
MDQM[1:0] delay time	t <sub>WROSD</sub>	MSDCLK, MDQM[1:0]	1	12	ns
MCSX delay time	t <sub>MCSSD</sub>	MSDCLK, MCSX8	2	12	ns
MRASX delay time	t <sub>RASSD</sub>	MSDCLK, MRASX	2	12	ns
MCASX delay time	t <sub>CASSD</sub>	MSDCLK, MCASX	2	12	ns
MSDWEX delay time	t <sub>MWESD</sub>	MSDCLK, MSDWEX	2	12	ns
MSDCKE delay time	t <sub>CKESD</sub>	MSDCLK, MSDCKE	2	12	ns
Data set up time	t <sub>DSSD</sub>	MSDCLK, MADATA[31:0]	23	-	ns
Data hold time	t <sub>DHSD</sub>	MSDCLK, MADATA[31:0]	0	-	ns

**Note:**

- When the external load capacitance C<sub>L</sub> = 30Pf

SDRAM Access

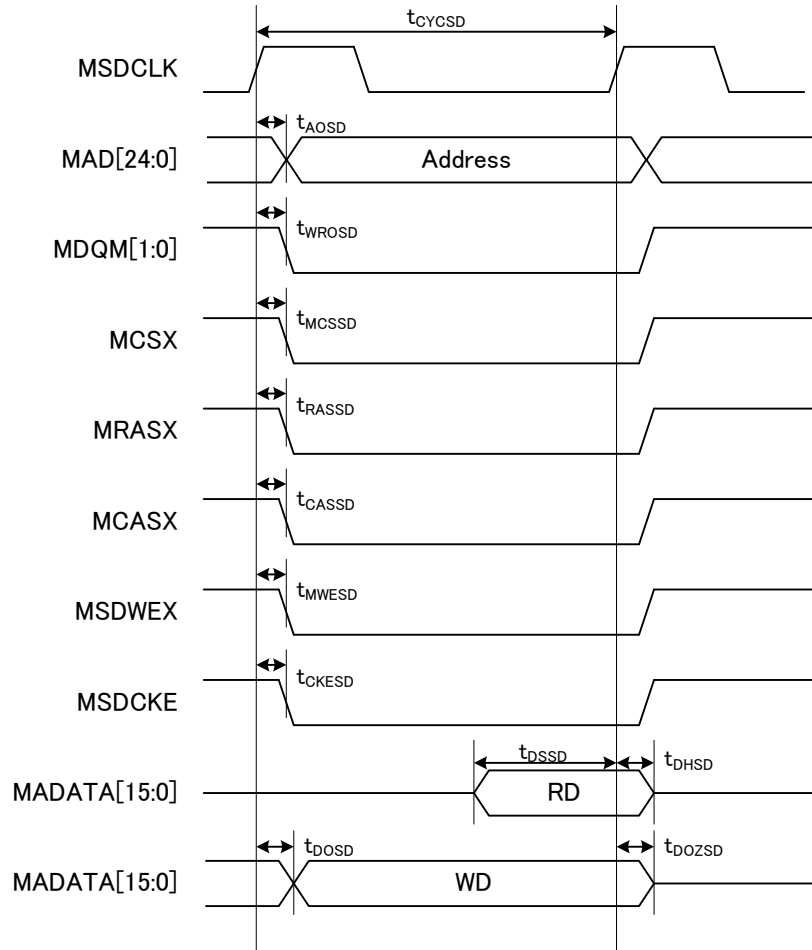

12.4.10 Base Timer Input Timing

Timer input timing

(V<sub>CC</sub> = 2.7V to 5.5V, V<sub>SS</sub> = 0V)

Parameter	Symbol	Pin name	Conditions	Value		Unit	Remarks
				Min	Max		
Input pulse width	$t_{TIWH}, t_{TIWL}$	TIOAn/TIOBn (when using as ECK, TIN)	-	$2t_{CYCP}$	-	ns	

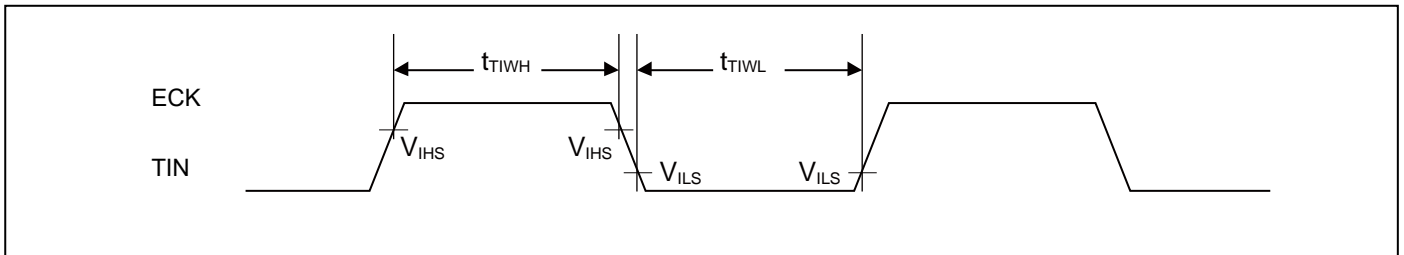

Trigger input timing

(V<sub>CC</sub> = 2.7V to 5.5V, V<sub>SS</sub> = 0V)

Parameter	Symbol	Pin name	Conditions	Value		Unit	Remarks
				Min	Max		
Input pulse width	$t_{TRGH}, t_{TRGL}$	TIOAn/TIOBn (when using as TGIN)	-	$2t_{CYCP}$	-	ns	

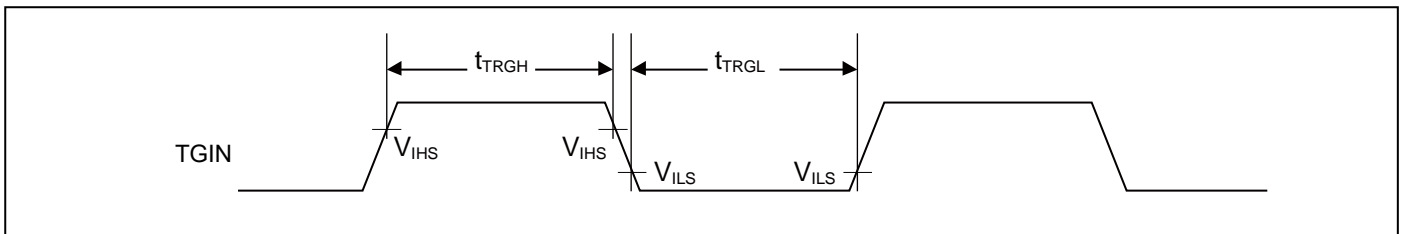

**Note:**

$t_{CYCP}$  indicates the APB bus clock cycle time.

About the APB bus number which the Base Timer is connected to, see “Block Diagram” in this datasheet.

**12.4.11 CSIO/UART Timing**
**Synchronous serial (SPI = 0, SCINV = 0)**
*(V<sub>CC</sub> = 2.7V to 5.5V, V<sub>SS</sub> = 0V)*

Parameter	Symbol	Pin name	Conditions	V <sub>CC</sub> < 4.5V		V <sub>CC</sub> ≥ 4.5V		Unit
				Min	Max	Min	Max	
Baud rate	-	-	-	-	8	-	8	Mbps
Serial clock cycle time	t <sub>SCYC</sub>	SCKx	Internal shift clock operation	4t <sub>CYCP</sub>	-	4t <sub>CYCP</sub>	-	ns
SCK↓→SOT delay time	t <sub>SLOVI</sub>	SCKx, SOTx		- 30	+ 30	- 20	+ 20	ns
SIN→SCK↑ setup time	t <sub>IVSHI</sub>	SCKx, SINx		50	-	30	-	ns
SCK↑→SIN hold time	t <sub>SHIXI</sub>	SCKx, SINx		0	-	0	-	ns
Serial clock "L" pulse width	t <sub>SLSH</sub>	SCKx	External shift clock operation	2t <sub>CYCP</sub> - 10	-	2t <sub>CYCP</sub> - 10	-	ns
Serial clock "H" pulse width	t <sub>SHSL</sub>	SCKx		t <sub>CYCP</sub> + 10	-	t <sub>CYCP</sub> + 10	-	ns
SCK↓→SOT delay time	t <sub>SLOVE</sub>	SCKx, SOTx		-	50	-	30	ns
SIN→SCK↑ setup time	t <sub>IVSHE</sub>	SCKx, SINx		10	-	10	-	ns
SCK↑→SIN hold time	t <sub>SHIXE</sub>	SCKx, SINx		20	-	20	-	ns
SCK falling time	T <sub>f</sub>	SCKx		-	5	-	5	ns
SCK rising time	T <sub>r</sub>	SCKx	-	5	-	5	ns	

**Notes:**

- The above characteristics apply to CLK synchronous mode.
- t<sub>CYCP</sub> indicates the APB bus clock cycle time.  
About the APB bus number which UART is connected to, see "Block Diagram" in this datasheet.
- These characteristics only guarantee the same relocate port number.  
For example, the combination of SCKx\_0 and SOTx\_1 is not guaranteed.
- When the external load capacitance C<sub>L</sub> = 30Pf.

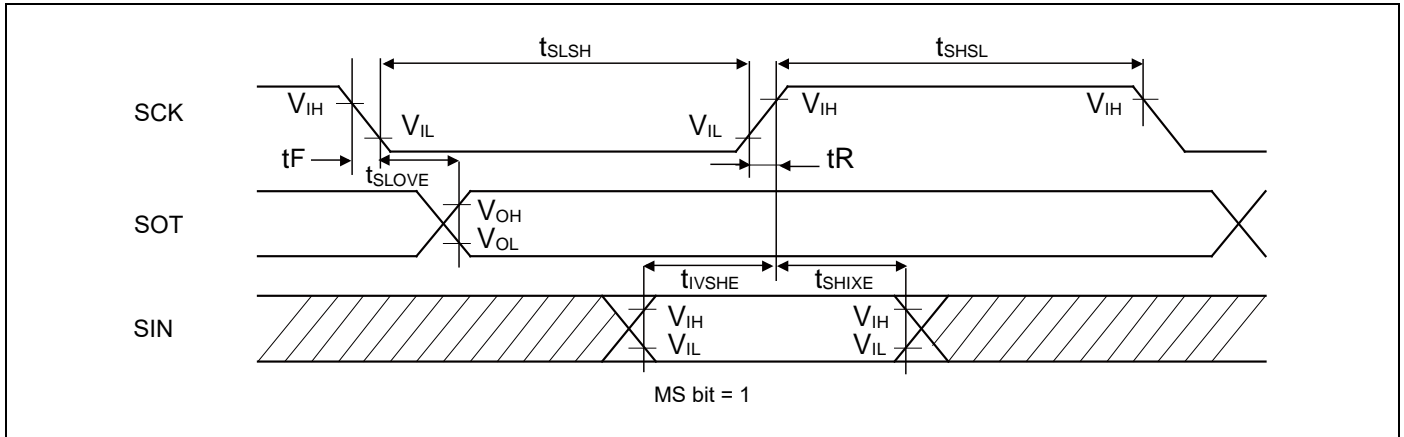
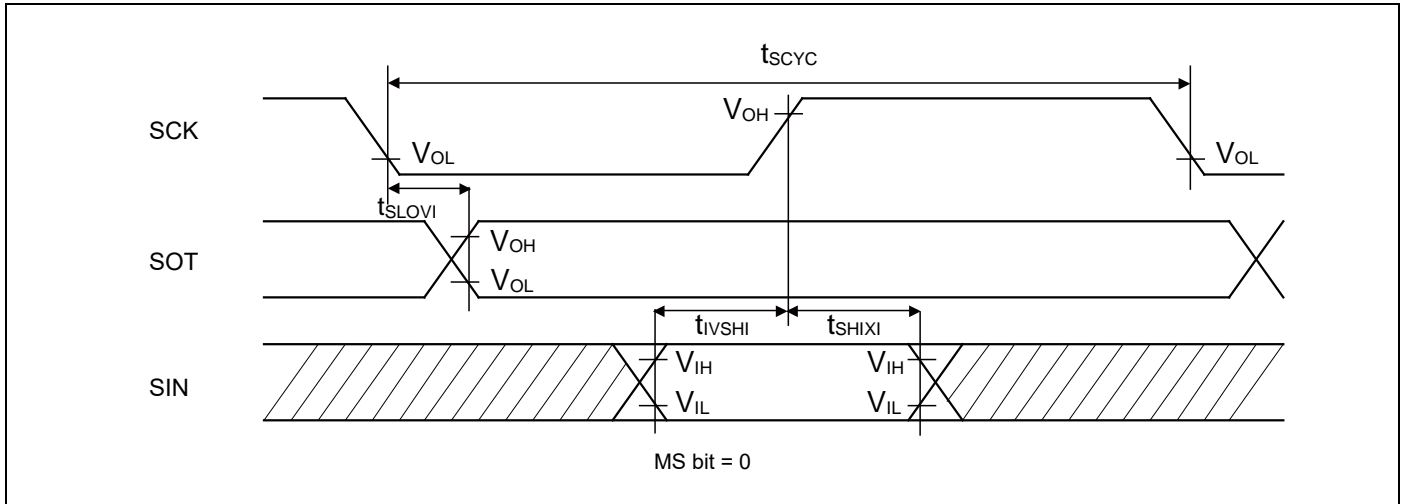

## Synchronous serial (SPI = 0, SCINV = 1)

(V<sub>CC</sub> = 2.7V to 5.5V, V<sub>SS</sub> = 0V)

Parameter	Symbol	Pin name	Conditions	V <sub>CC</sub> < 4.5V		V <sub>CC</sub> ≥ 4.5V		Unit
				Min	Max	Min	Max	
Baud rate	-	-	-	-	8	-	8	Mbps
Serial clock cycle time	t <sub>SCYC</sub>	SCKx	Internal shift clock operation	4t <sub>CYCP</sub>	-	4t <sub>CYCP</sub>	-	ns
SCK↑→SOT delay time	t <sub>SHOVI</sub>	SCKx, SOTx		- 30	+ 30	- 20	+ 20	ns
SIN→SCK↓ setup time	t <sub>IVSLI</sub>	SCKx, SINx		50	-	30	-	ns
SCK↓→SIN hold time	t <sub>SLIXI</sub>	SCKx, SINx		0	-	0	-	ns
Serial clock "L" pulse width	t <sub>GLSH</sub>	SCKx		2t <sub>CYCP</sub> - 10	-	2t <sub>CYCP</sub> - 10	-	ns
Serial clock "H" pulse width	t <sub>SHSL</sub>	SCKx	t <sub>CYCP</sub> + 10	-	t <sub>CYCP</sub> + 10	-	ns	
SCK↑→SOT delay time	t <sub>SHOVE</sub>	SCKx, SOTx	External shift clock operation	-	50	-	30	ns
SIN→SCK↓ setup time	t <sub>IVSLE</sub>	SCKx, SINx		10	-	10	-	ns
SCK↓→SIN hold time	t <sub>SLIXE</sub>	SCKx, SINx		20	-	20	-	ns
SCK falling time	T <sub>f</sub>	SCKx		-	5	-	5	ns
SCK rising time	T <sub>r</sub>	SCKx		-	5	-	5	ns

### Notes:

- The above characteristics apply to CLK synchronous mode.
- t<sub>CYCP</sub> indicates the APB bus clock cycle time.  
About the APB bus number which UART is connected to, see "Block Diagram" in this datasheet.
- These characteristics only guarantee the same relocate port number.  
For example, the combination of SCKx\_0 and SOTx\_1 is not guaranteed.
- When the external load capacitance C<sub>L</sub> = 30Pf.

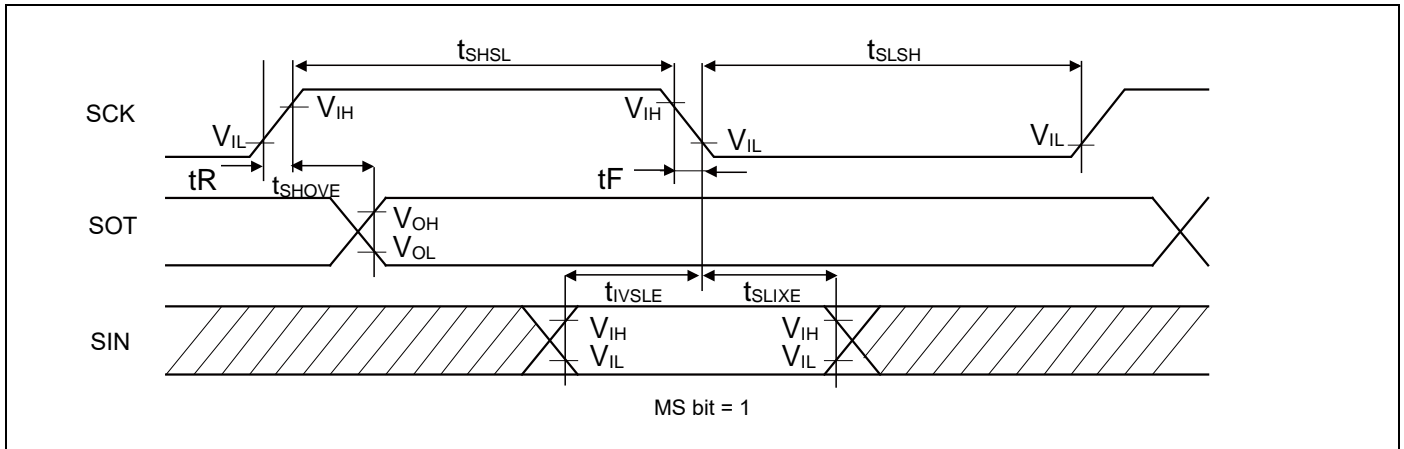
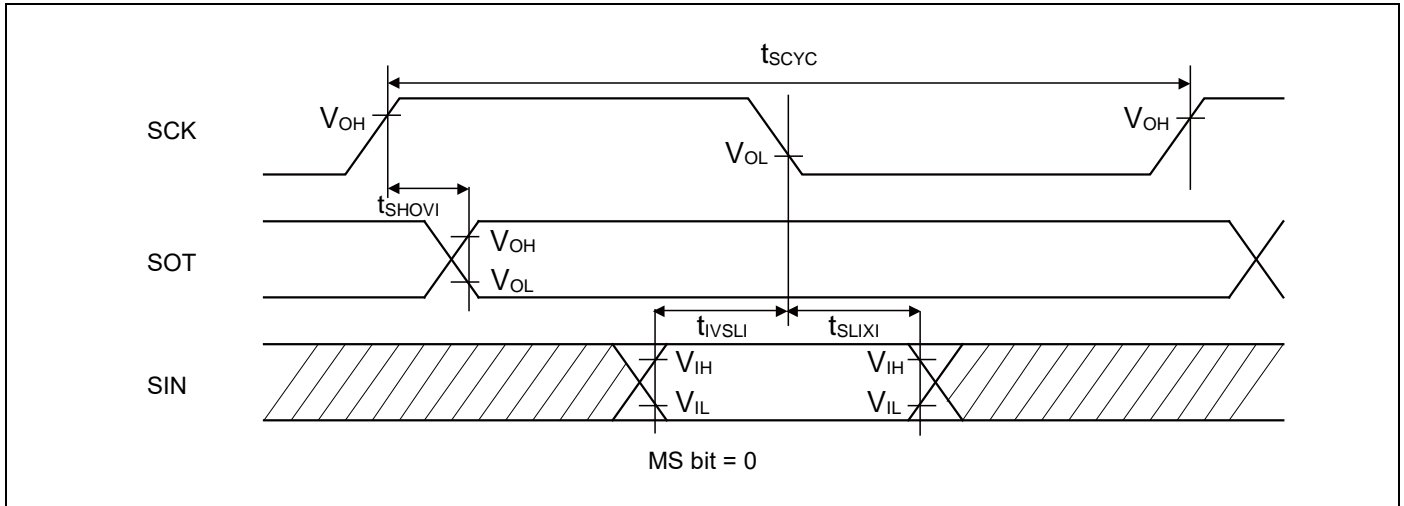

## Synchronous serial (SPI = 1, SCINV = 0)

(V<sub>CC</sub> = 2.7V to 5.5V, V<sub>SS</sub> = 0V)

Parameter	Symbol	Pin name	Conditions	V <sub>CC</sub> < 4.5V		V <sub>CC</sub> ≥ 4.5V		Unit
				Min	Max	Min	Max	
Baud rate	-	-	-	-	8	-	8	Mbps
Serial clock cycle time	t <sub>SCYC</sub>	SCKx	Internal shift clock operation	4t <sub>CYCP</sub>	-	4t <sub>CYCP</sub>	-	ns
SCK↑→SOT delay time	t <sub>SHOVI</sub>	SCKx, SOTx		- 30	+ 30	- 20	+ 20	ns
SIN→SCK↓ setup time	t <sub>IVSLI</sub>	SCKx, SINx		50	-	30	-	ns
SCK↓→SIN hold time	t <sub>SLIXI</sub>	SCKx, SINx		0	-	0	-	ns
SOT→SCK↓ delay time	t <sub>SOVLI</sub>	SCKx, SOTx		2t <sub>CYCP</sub> - 30	-	2t <sub>CYCP</sub> - 30	-	ns
Serial clock "L" pulse width	t <sub>SLSH</sub>	SCKx		2t <sub>CYCP</sub> - 10	-	2t <sub>CYCP</sub> - 10	-	ns
Serial clock "H" pulse width	t <sub>SHSL</sub>	SCKx	t <sub>CYCP</sub> + 10	-	t <sub>CYCP</sub> + 10	-	ns	
SCK↑→SOT delay time	t <sub>SHOVE</sub>	SCKx, SOTx	External shift clock operation	-	50	-	30	ns
SIN→SCK↓ setup time	t <sub>IVSLE</sub>	SCKx, SINx		10	-	10	-	ns
SCK↓→SIN hold time	t <sub>SLIXE</sub>	SCKx, SINx		20	-	20	-	ns
SCK falling time	T <sub>f</sub>	SCKx		-	5	-	5	ns
SCK rising time	T <sub>r</sub>	SCKx		-	5	-	5	ns

### Notes:

- The above characteristics apply to CLK synchronous mode.
- t<sub>CYCP</sub> indicates the APB bus clock cycle time.
- About the APB bus number which UART is connected to, see "Block Diagram" in this datasheet.
- These characteristics only guarantee the same relocate port number. For example, the combination of SCKx\_0 and SOTx\_1 is not guaranteed.
- When the external load capacitance C<sub>L</sub> = 30Pf.

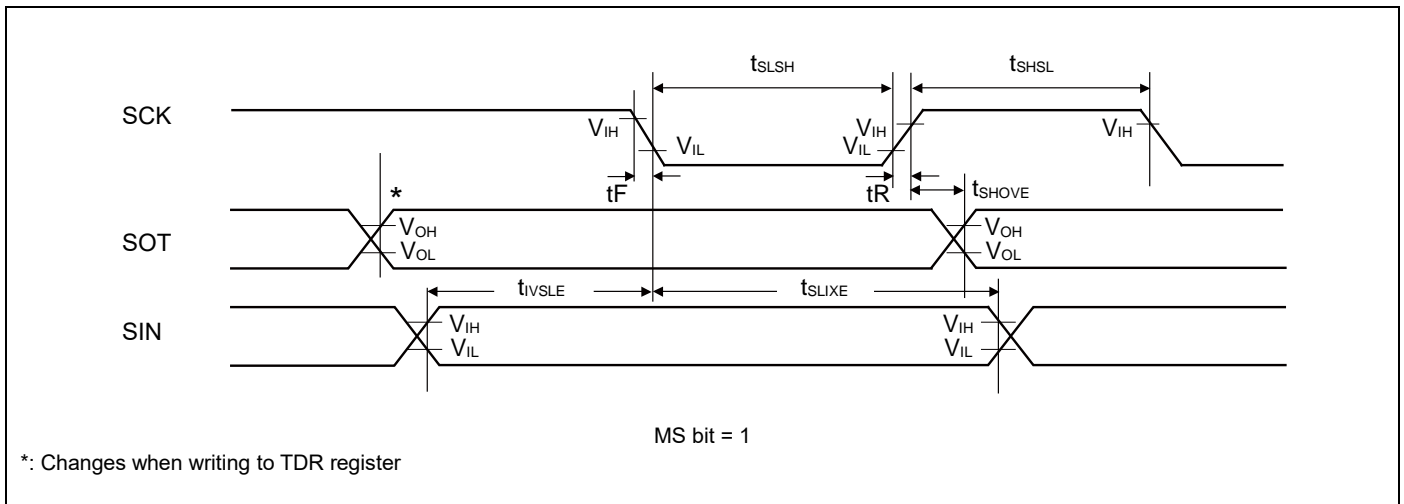
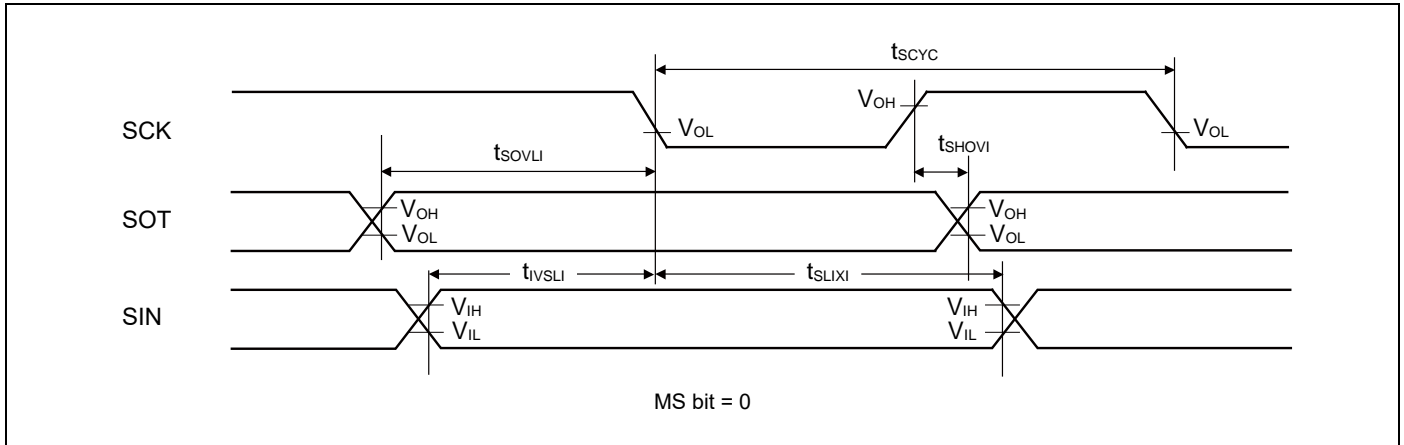

## Synchronous serial (SPI = 1, SCINV = 1)

(V<sub>CC</sub> = 2.7V to 5.5V, V<sub>SS</sub> = 0V)

Parameter	Symbol	Pin name	Conditions	V <sub>CC</sub> < 4.5V		V <sub>CC</sub> ≥ 4.5V		Unit
				Min	Max	Min	Max	
Baud rate	-	-	-	-	8	-	8	Mbps
Serial clock cycle time	t <sub>SCYC</sub>	SCKx	Internal shift clock operation	4t <sub>CYCP</sub>	-	4t <sub>CYCP</sub>	-	ns
SCK↓→SOT delay time	t <sub>SLOVI</sub>	SCKx, SOTx		- 30	+ 30	- 20	+ 20	ns
SIN→SCK↑ setup time	t <sub>IVSHI</sub>	SCKx, SINx		50	-	30	-	ns
SCK↑→SIN hold time	t <sub>SHIXI</sub>	SCKx, SINx		0	-	0	-	ns
SOT→SCK↑ delay time	t <sub>SOVHI</sub>	SCKx, SOTx		2t <sub>CYCP</sub> - 30	-	2t <sub>CYCP</sub> - 30	-	ns
Serial clock "L" pulse width	t <sub>SLSH</sub>	SCKx	External shift clock operation	2t <sub>CYCP</sub> - 10	-	2t <sub>CYCP</sub> - 10	-	ns
Serial clock "H" pulse width	t <sub>SHSL</sub>	SCKx		t <sub>CYCP</sub> + 10	-	t <sub>CYCP</sub> + 10	-	ns
SCK↓→SOT delay time	t <sub>SLOVE</sub>	SCKx, SOTx		-	50	-	30	ns
SIN→SCK↑ setup time	t <sub>IVSHE</sub>	SCKx, SINx		10	-	10	-	ns
SCK↑→SIN hold time	t <sub>SHIXE</sub>	SCKx, SINx		20	-	20	-	ns
SCK falling time	T <sub>f</sub>	SCKx		-	5	-	5	ns
SCK rising time	T <sub>r</sub>	SCKx		-	5	-	5	ns

### Notes:

- The above characteristics apply to CLK synchronous mode.
- t<sub>CYCP</sub> indicates the APB bus clock cycle time.  
About the APB bus number which UART is connected to, see "Block Diagram" in this datasheet.
- These characteristics only guarantee the same relocate port number.  
For example, the combination of SCKx\_0 and SOTx\_1 is not guaranteed.
- When the external load capacitance C<sub>L</sub> = 30Pf.

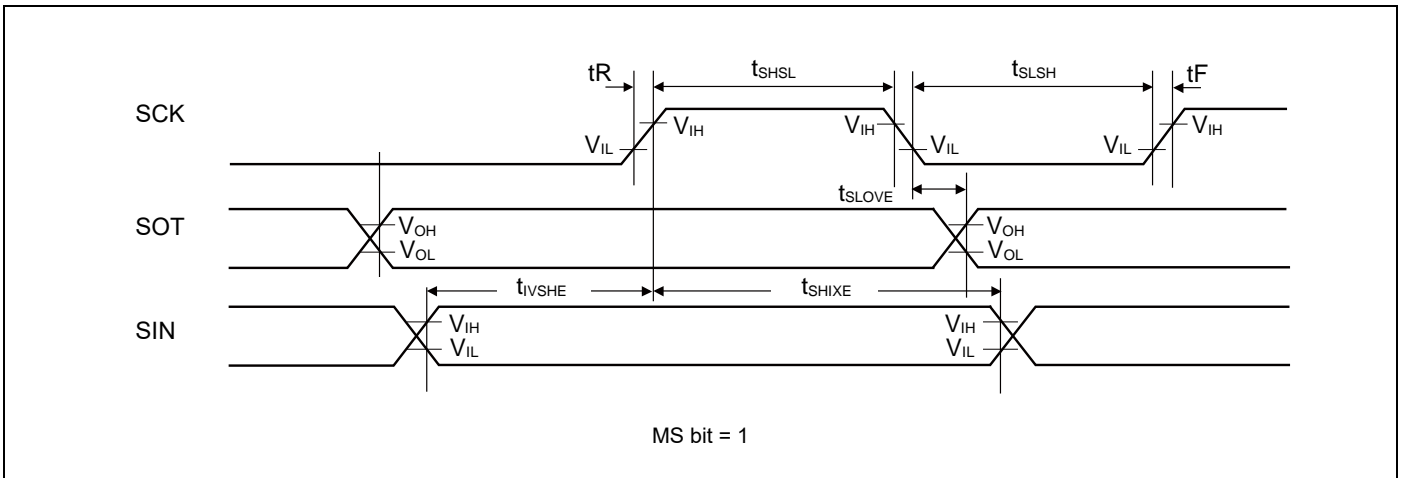
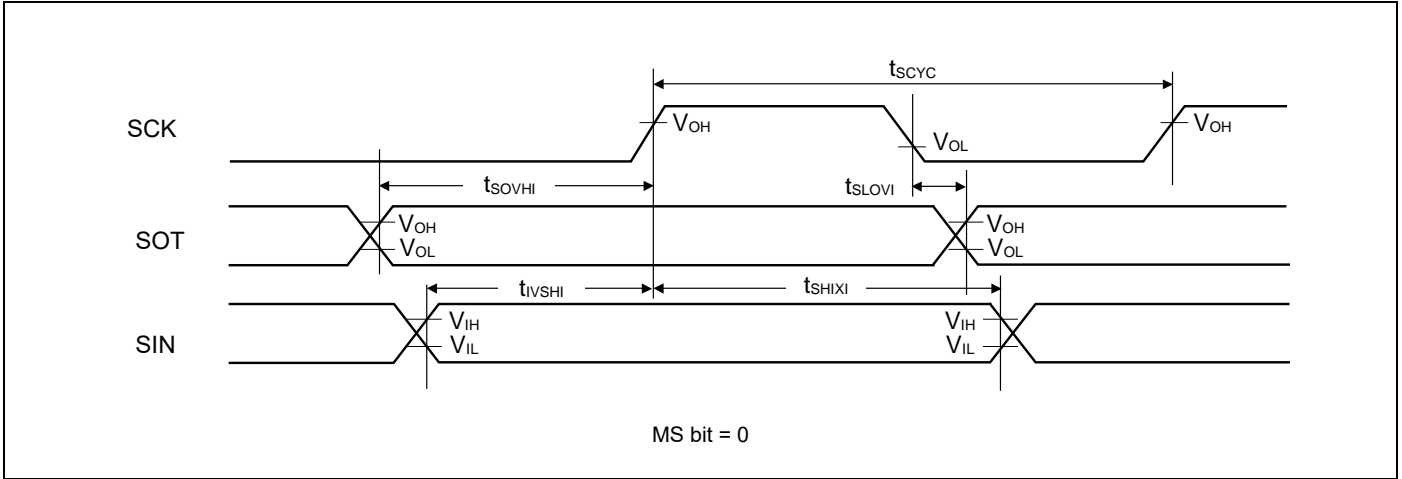

## When using synchronous serial chip select (SCINV = 0, CSLVL = 1)

(V<sub>CC</sub> = 2.7V to 5.5V, V<sub>SS</sub> = 0V)

Parameter	Symbol	Conditions	V <sub>CC</sub> < 4.5V		V <sub>CC</sub> ≥ 4.5V		Unit
			Min	Max	Min	Max	
SCS↓→SCK↓setup time	t <sub>CSSI</sub>	Internal shift clock operation	(*1)-50	(*1)+0	(*1)-50	(*1)+0	ns
SCK↑→SCS↑ hold time	t <sub>CSEH</sub>		(*2)+0	(*2)+50	(*2)+0	(*2)+50	ns
SCS deselect time	t <sub>CSDI</sub>		(*3)-50 +5t <sub>CYCP</sub>	(*3)+50 +5t <sub>CYCP</sub>	(*3)-50 +5t <sub>CYCP</sub>	(*3)+50 +5t <sub>CYCP</sub>	ns
SCS↓→SCK↓setup time	t <sub>CSE</sub>	External shift clock operation	3t <sub>CYCP</sub> +30	-	3t <sub>CYCP</sub> +30	-	ns
SCK↑→SCS↑ hold time	t <sub>CSEH</sub>		0	-	0	-	ns
SCS deselect time	t <sub>CSE</sub>		3t <sub>CYCP</sub> +30	-	3t <sub>CYCP</sub> +30	-	ns
SCS↓→SUT delay time	t <sub>DSE</sub>		-	40	-	40	ns
SCS↑→SUT delay time	t <sub>DEE</sub>		0	-	0	-	ns

(\*1): CSSU bit value×serial chip select timing operating clock cycle [ns]

(\*2): CSHD bit value×serial chip select timing operating clock cycle [ns]

(\*3): CSDS bit value×serial chip select timing operating clock cycle [ns]

### Notes:

- t<sub>CYCP</sub> indicates the APB bus clock cycle time.  
About the APB bus number which UART is connected to, see "Block Diagram" in this datasheet.
- About CSSU, CSHD, CSDS, serial chip select timing operating clock, see "FM4 Family Peripheral Manual".
- When the external load capacitance C<sub>L</sub> = 30Pf.

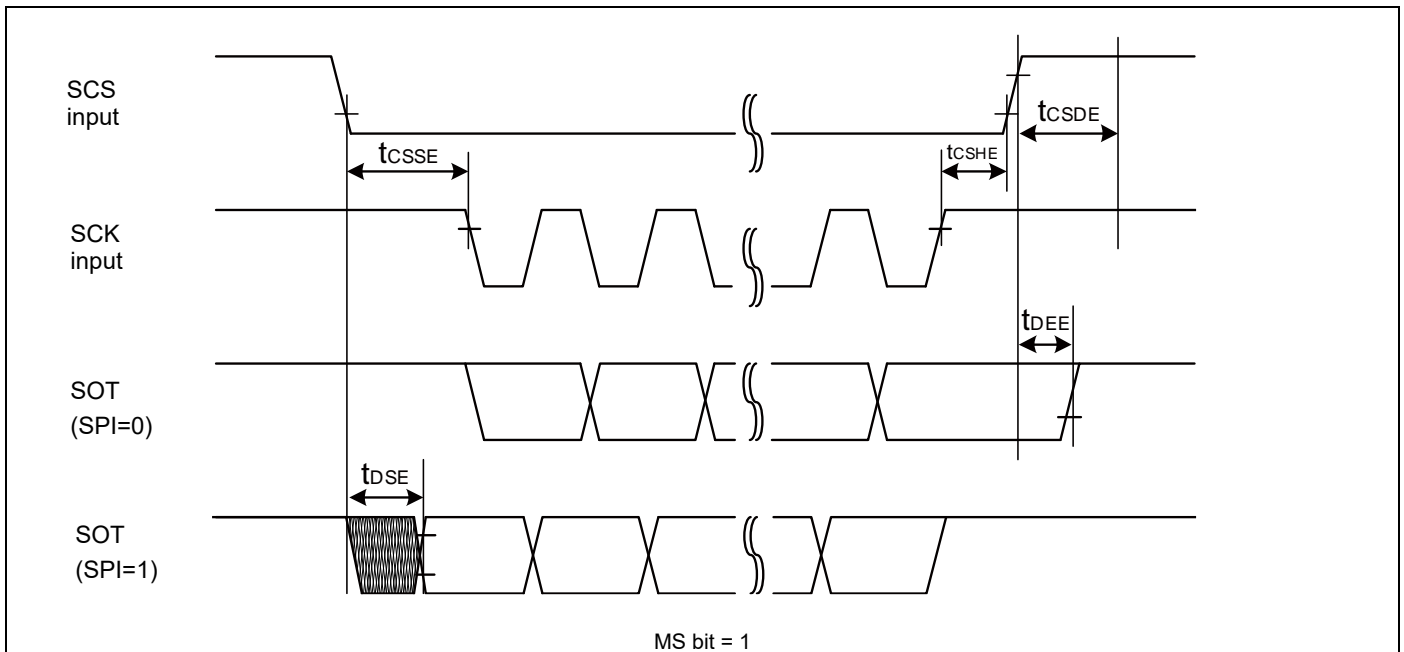
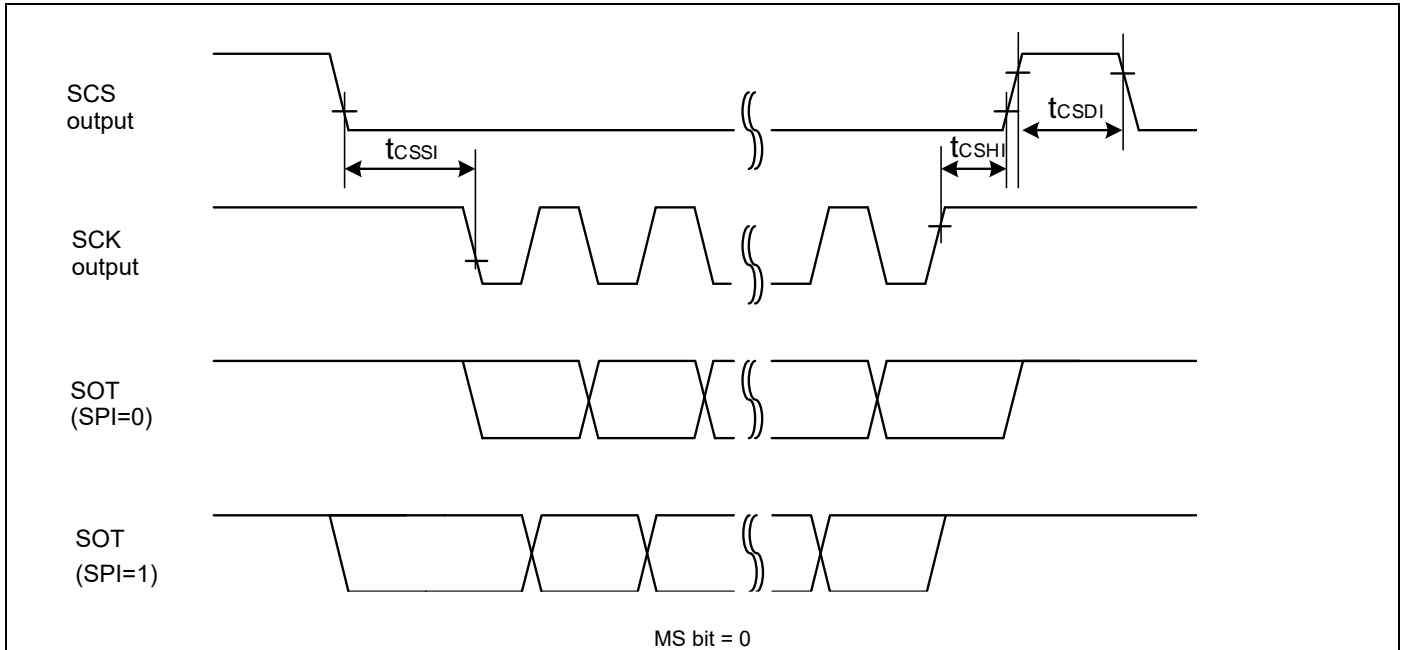

**When using synchronous serial chip select (SCINV = 1, CSLVL = 1)**

 (V<sub>CC</sub> = 2.7V to 5.5V, V<sub>SS</sub> = 0V)

Parameter	Symbol	Conditions	V <sub>CC</sub> < 4.5V		V <sub>CC</sub> ≥ 4.5V		Unit
			Min	Max	Min	Max	
SCS↓→SCK↑setup time	t <sub>CSSI</sub>	Internal shift clock operation	(*1)-50	(*1)+0	(*1)-50	(*1)+0	ns
SCK↓→SCS↑ hold time	t <sub>CShI</sub>		(*2)+0	(*2)+50	(*2)+0	(*2)+50	ns
SCS deselect time	t <sub>CSDI</sub>		(*3)-50 +5t <sub>CYCP</sub>	(*3)+50 +5t <sub>CYCP</sub>	(*3)-50 +5t <sub>CYCP</sub>	(*3)+50 +5t <sub>CYCP</sub>	ns
SCS↓→SCK↑setup time	t <sub>CSE</sub>	External shift clock operation	3t <sub>CYCP</sub> +30	-	3t <sub>CYCP</sub> +30	-	ns
SCK↓→SCS↑ hold time	t <sub>CSE</sub>		0	-	0	-	ns
SCS deselect time	t <sub>CSE</sub>		3t <sub>CYCP</sub> +30	-	3t <sub>CYCP</sub> +30	-	ns
SCS↓→SOT delay time	t <sub>DSE</sub>		-	40	-	40	ns
SCS↑→SOT delay time	t <sub>DEE</sub>		0	-	0	-	ns

(\*1): CSSU bit value×serial chip select timing operating clock cycle [ns]

(\*2): CSHD bit value×serial chip select timing operating clock cycle [ns]

(\*3): CSDS bit value×serial chip select timing operating clock cycle [ns]

**Notes:**

- t<sub>CYCP</sub> indicates the APB bus clock cycle time.  
About the APB bus number which UART is connected to, see “Block Diagram” in this datasheet.
- About CSSU, CSHD, CSDS, serial chip select timing operating clock, see “FM4 Family Peripheral Manual”.
- When the external load capacitance C<sub>L</sub> = 30Pf.

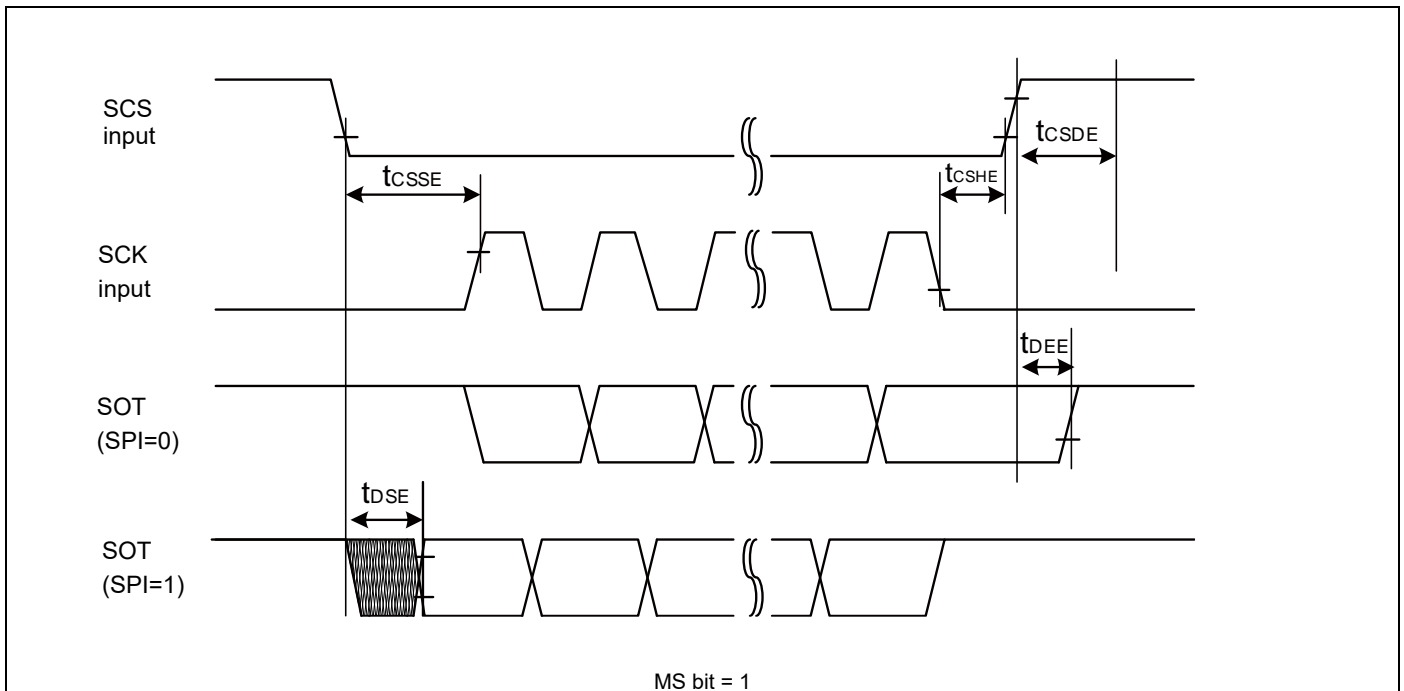
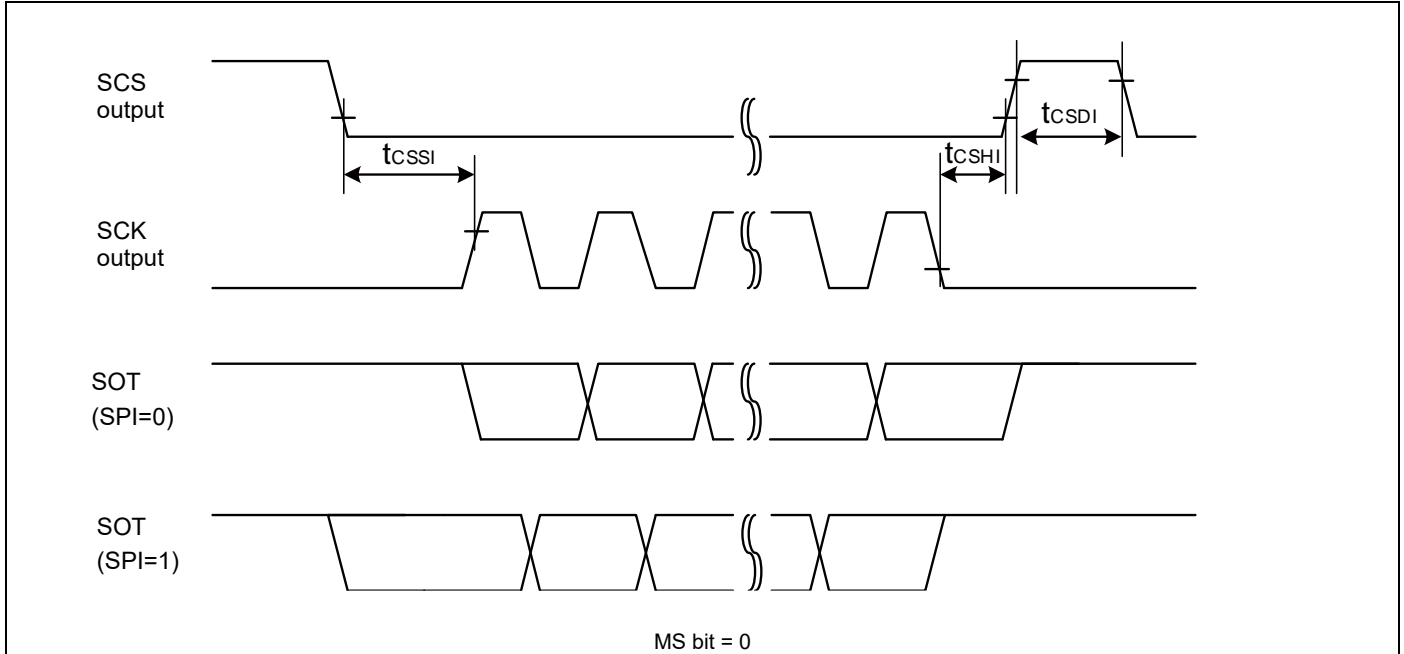

## When using synchronous serial chip select (SCINV = 0, CSLVL = 0)

(V<sub>CC</sub> = 2.7V to 5.5V, V<sub>SS</sub> = 0V)

Parameter	Symbol	Conditions	V <sub>CC</sub> < 4.5V		V <sub>CC</sub> ≥ 4.5V		Unit
			Min	Max	Min	Max	
SCS↑→SCK↓setup time	t <sub>CSSI</sub>	Internal shift clock operation	(*1)-50	(*1)+0	(*1)-50	(*1)+0	ns
SCK↑→SCS↓ hold time	t <sub>CShI</sub>		(*2)+0	(*2)+50	(*2)+0	(*2)+50	ns
SCS deselect time	t <sub>CSDI</sub>		(*3)-50 +5t <sub>CYCP</sub>	(*3)+50 +5t <sub>CYCP</sub>	(*3)-50 +5t <sub>CYCP</sub>	(*3)+50 +5t <sub>CYCP</sub>	ns
SCS↑→SCK↓setup time	t <sub>CSSe</sub>	External shift clock operation	3t <sub>CYCP</sub> +30	-	3t <sub>CYCP</sub> +30	-	ns
SCK↑→SCS↓ hold time	t <sub>CShE</sub>		0	-	0	-	ns
SCS deselect time	t <sub>CSDe</sub>		3t <sub>CYCP</sub> +30	-	3t <sub>CYCP</sub> +30	-	ns
SCS↑→SOT delay time	t <sub>DSE</sub>		-	40	-	40	ns
SCS↓→SOT delay time	t <sub>DEE</sub>		0	-	0	-	ns

(\*1): CSSU bit value×serial chip select timing operating clock cycle [ns]

(\*2): CSHD bit value×serial chip select timing operating clock cycle [ns]

(\*3): CSDS bit value×serial chip select timing operating clock cycle [ns]

### Notes:

- t<sub>CYCP</sub> indicates the APB bus clock cycle time.  
About the APB bus number which UART is connected to, see “Block Diagram” in this datasheet.
- About CSSU, CSHD, CSDS, serial chip select timing operating clock, see “FM4 Family Peripheral Manual”.
- When the external load capacitance C<sub>L</sub> = 30Pf.

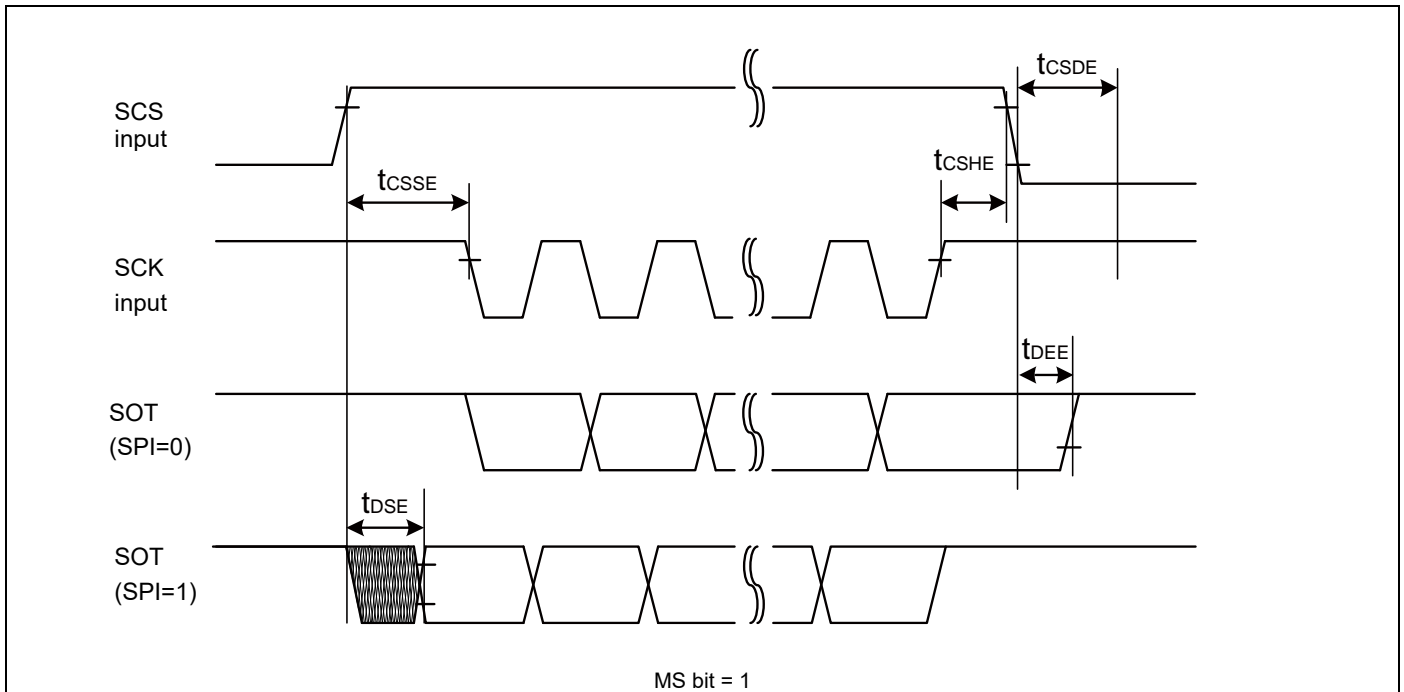
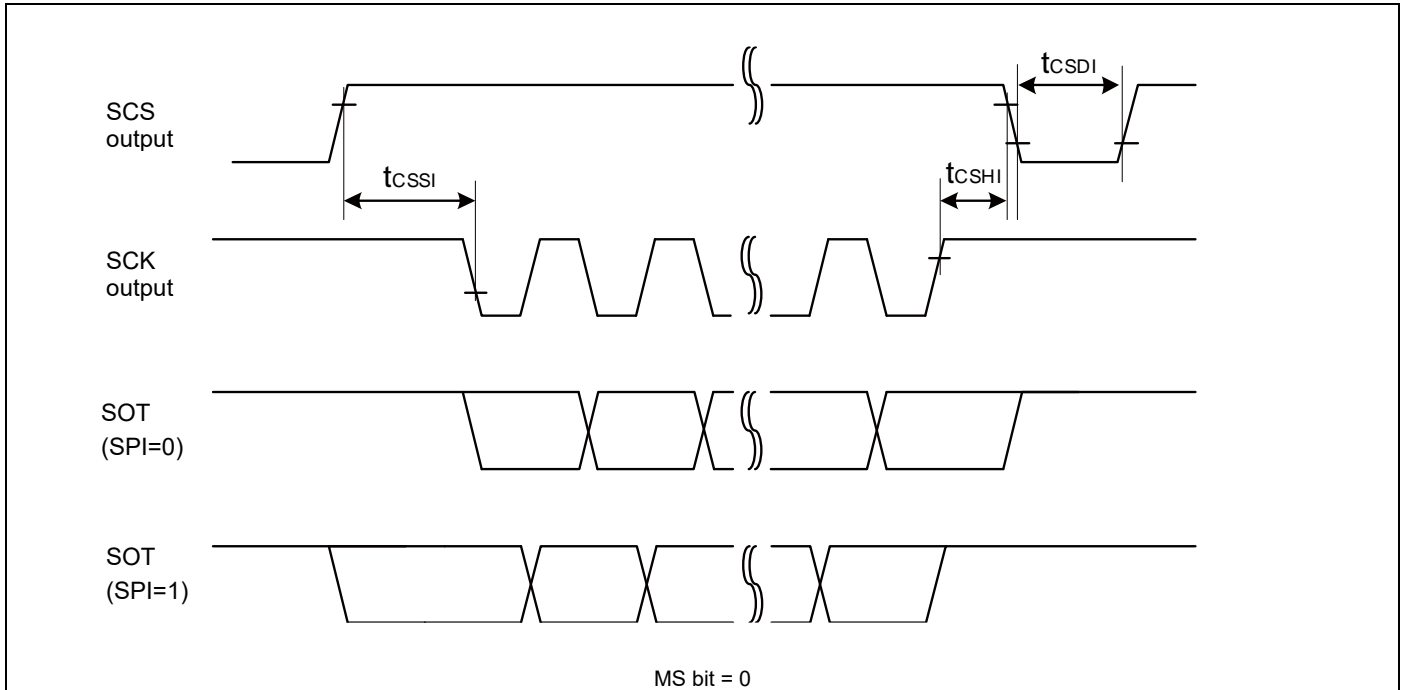

## When using synchronous serial chip select (SCINV = 1, CSLVL = 0)

(V<sub>CC</sub> = 2.7V to 5.5V, V<sub>SS</sub> = 0V)

Parameter	Symbol	Conditions	V <sub>CC</sub> < 4.5V		V <sub>CC</sub> ≥ 4.5V		Unit
			Min	Max	Min	Max	
SCS↑→SCK↑setup time	t <sub>CSSI</sub>	Internal shift clock operation	(*1)-50	(*1)+0	(*1)-50	(*1)+0	ns
SCK↓→SCS↓ hold time	t <sub>CShI</sub>		(*2)+0	(*2)+50	(*2)+0	(*2)+50	ns
SCS deselect time	t <sub>CSDI</sub>		(*3)-50 +5t <sub>CYCP</sub>	(*3)+50 +5t <sub>CYCP</sub>	(*3)-50 +5t <sub>CYCP</sub>	(*3)+50 +5t <sub>CYCP</sub>	ns
SCS↑→SCK↑setup time	t <sub>CSSe</sub>	External shift clock operation	3t <sub>CYCP</sub> +30	-	3t <sub>CYCP</sub> +30	-	ns
SCK↓→SCS↓ hold time	t <sub>CShE</sub>		0	-	0	-	ns
SCS deselect time	t <sub>CSDe</sub>		3t <sub>CYCP</sub> +30	-	3t <sub>CYCP</sub> +30	-	ns
SCS↑→SOT delay time	t <sub>DSE</sub>		-	40	-	40	ns
SCS↓→SOT delay time	t <sub>DEE</sub>		0	-	0	-	ns

(\*1): CSSU bit value×serial chip select timing operating clock cycle [ns]

(\*2): CSHD bit value×serial chip select timing operating clock cycle [ns]

(\*3): CSDS bit value×serial chip select timing operating clock cycle [ns]

### Notes:

- t<sub>CYCP</sub> indicates the APB bus clock cycle time.  
About the APB bus number which UART is connected to, see "Block Diagram" in this datasheet.
- About CSSU, CSHD, CSDS, serial chip select timing operating clock, see "FM4 Family Peripheral Manual".
- When the external load capacitance C<sub>L</sub> = 30Pf.

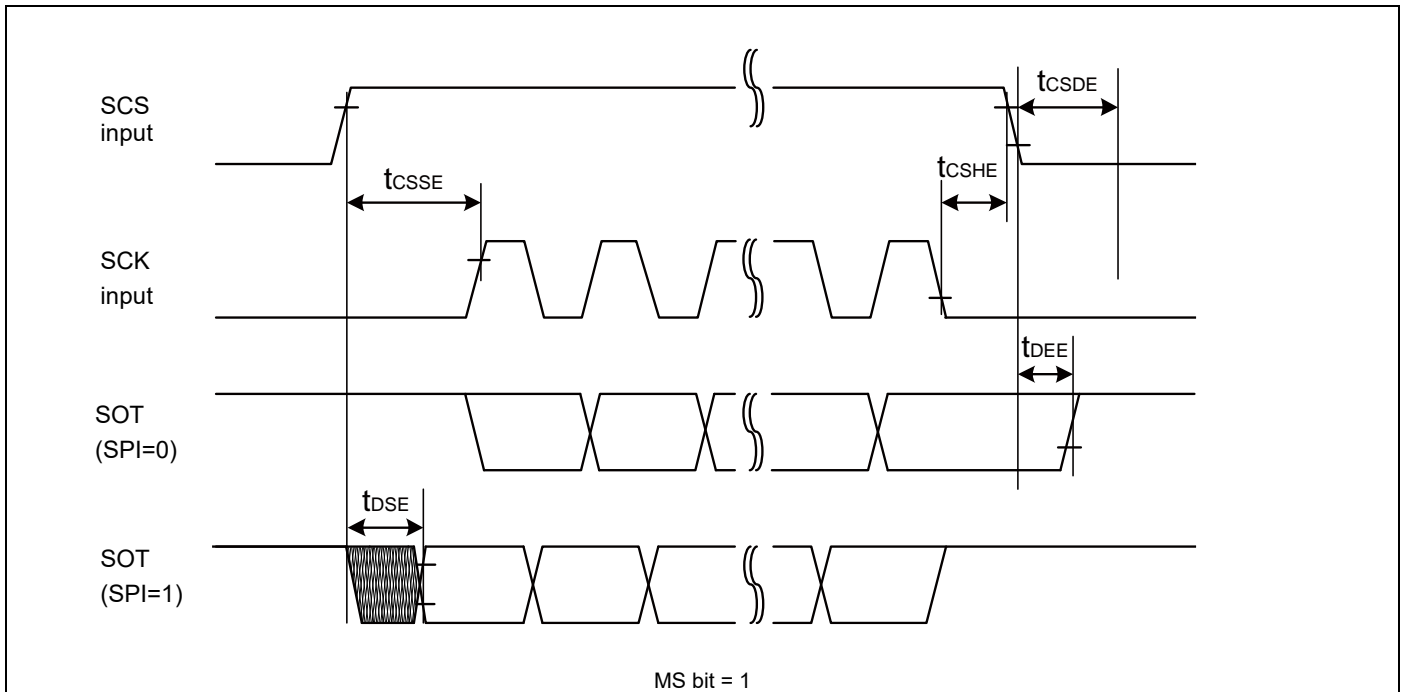
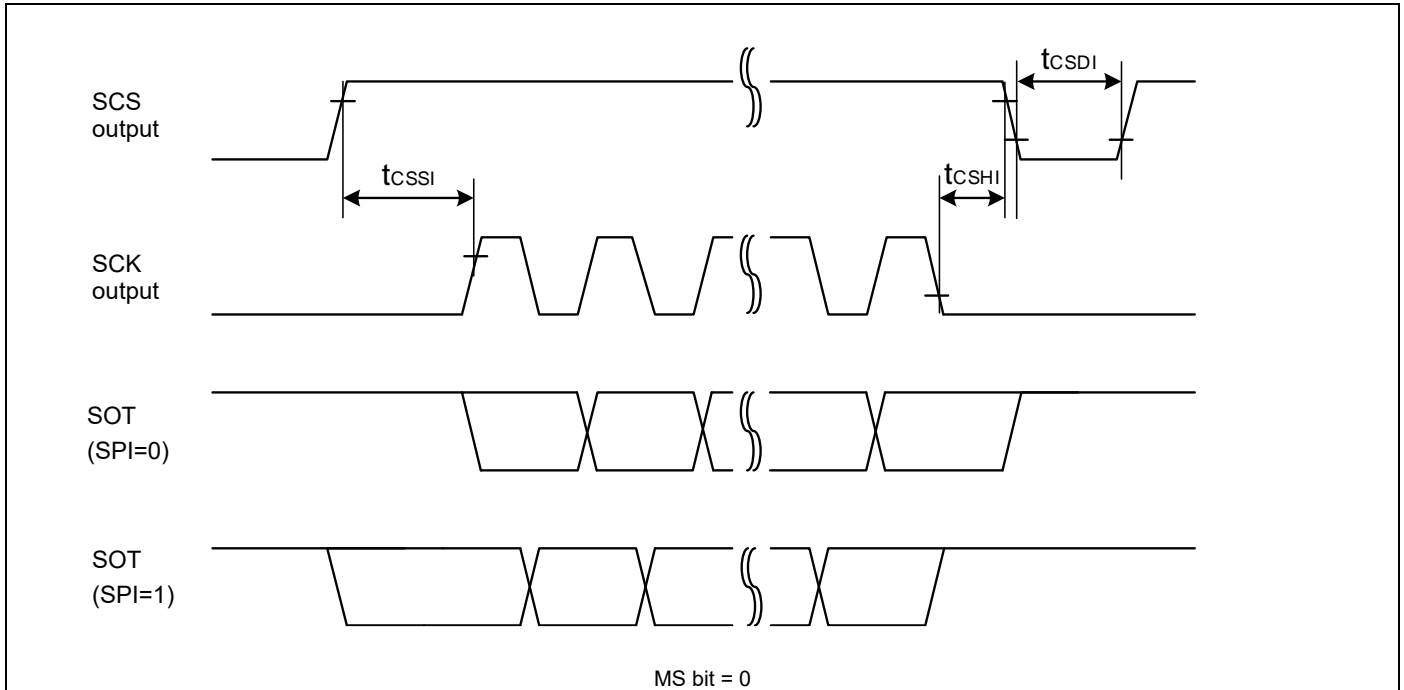

**High-speed synchronous serial (SPI = 0, SCINV = 0)**

 (V<sub>CC</sub> = 2.7V to 5.5V, V<sub>SS</sub> = 0V)

Parameter	Symbol	Pin name	Conditions	V <sub>CC</sub> < 4.5V		V <sub>CC</sub> ≥ 4.5V		Unit
				Min	Max	Min	Max	
Serial clock cycle time	t <sub>SCYC</sub>	SCKx	Internal shift clock operation	4t <sub>CYCP</sub>	-	4t <sub>CYCP</sub>	-	ns
SCK↓→SOT delay time	t <sub>SLOVI</sub>	SCKx, SOTx		-10	+10	-10	+10	ns
SIN→SCK↑ setup time	t <sub>IVSHI</sub>	SCKx, SINx		14	-	12.5	-	ns
				12.5*				
SCK↑→SIN hold time	t <sub>SHIXI</sub>	SCKx, SINx	5	-	5	-	ns	
Serial clock "L" pulse width	t <sub>SLSH</sub>	SCKx	External shift clock operation	2t <sub>CYCP</sub> - 5	-	2t <sub>CYCP</sub> - 5	-	ns
Serial clock "H" pulse width	t <sub>SHSL</sub>	SCKx		t <sub>CYCP</sub> + 10	-	t <sub>CYCP</sub> + 10	-	ns
SCK↓→SOT delay time	t <sub>SLOVE</sub>	SCKx, SOTx		-	15	-	15	ns
SIN→SCK↑ setup time	t <sub>IVSHE</sub>	SCKx, SINx		5	-	5	-	ns
SCK↑→SIN hold time	t <sub>SHIXE</sub>	SCKx, SINx		5	-	5	-	ns
SCK falling time	T <sub>f</sub>	SCKx		-	5	-	5	ns
SCK rising time	T <sub>r</sub>	SCKx		-	5	-	5	ns

**Notes:**

- The above characteristics apply to CLK synchronous mode.
- t<sub>CYCP</sub> indicates the APB bus clock cycle time.  
About the APB bus number which UART is connected to, see "Block Diagram" in this datasheet.
- These characteristics only guarantee the following pins.
  - No chip select: SIN4\_1, SOT4\_1, SCK4\_1
  - Chip select: SIN6\_1, SOT6\_1, SCK6\_1, SCS6\_1
- When the external load capacitance C<sub>L</sub> = 30Pf. (For \*, when C<sub>L</sub> = 10Pf)

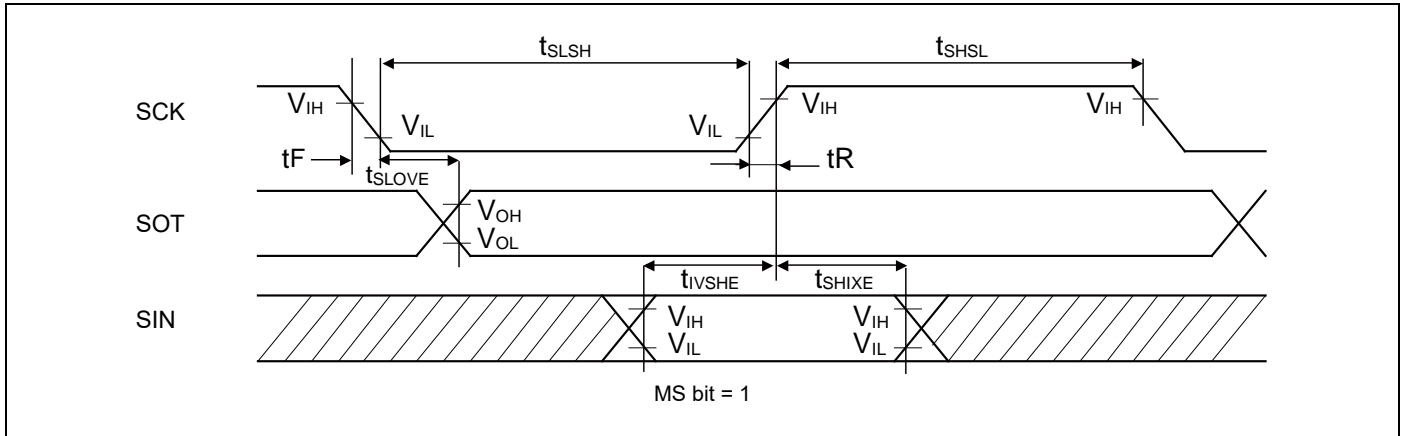
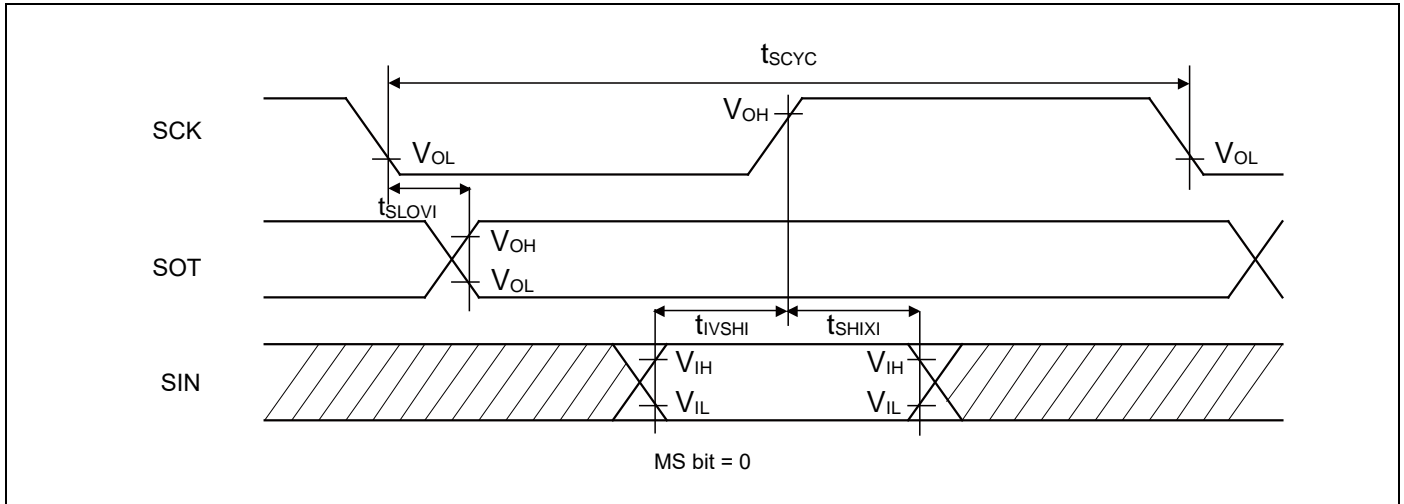

## High-speed synchronous serial (SPI = 0, SCINV = 1)

(V<sub>CC</sub> = 2.7V to 5.5V, V<sub>SS</sub> = 0V)

Parameter	Symbol	Pin name	Conditions	V <sub>CC</sub> < 4.5V		V <sub>CC</sub> ≥ 4.5V		Unit
				Min	Max	Min	Max	
Serial clock cycle time	t <sub>SCYC</sub>	SCKx	Internal shift clock operation	4t <sub>CYCP</sub>	-	4t <sub>CYCP</sub>	-	ns
SCK↑→SOT delay time	t <sub>SHOVI</sub>	SCKx, SOTx		-10	+10	-10	+10	ns
SIN→SCK↓ setup time	t <sub>IVSLI</sub>	SCKx, SINx		14	-	12.5	-	ns
				12.5*				
SCK↓→SIN hold time	t <sub>SLIXI</sub>	SCKx, SINx	5	-	5	-	ns	
Serial clock "L" pulse width	t <sub>SLSH</sub>	SCKx	External shift clock operation	2t <sub>CYCP</sub> - 5	-	2t <sub>CYCP</sub> - 5	-	ns
Serial clock "H" pulse width	t <sub>SHSL</sub>	SCKx		t <sub>CYCP</sub> + 10	-	t <sub>CYCP</sub> + 10	-	ns
SCK↑→SOT delay time	t <sub>SHOVE</sub>	SCKx, SOTx		-	15	-	15	ns
SIN→SCK↓ setup time	t <sub>IVSLE</sub>	SCKx, SINx		5	-	5	-	ns
SCK↓→SIN hold time	t <sub>SLIXE</sub>	SCKx, SINx		5	-	5	-	ns
SCK falling time	T <sub>f</sub>	SCKx		-	5	-	5	ns
SCK rising time	T <sub>r</sub>	SCKx		-	5	-	5	ns

### Notes:

- The above characteristics apply to CLK synchronous mode.
- t<sub>CYCP</sub> indicates the APB bus clock cycle time.  
About the APB bus number which UART is connected to, see "Block Diagram" in this datasheet.
- These characteristics only guarantee the following pins.
  - No chip select: SIN4\_1, SOT4\_1, SCK4\_1
  - Chip select: SIN6\_1, SOT6\_1, SCK6\_1, SCS6\_1
- When the external load capacitance C<sub>L</sub> = 30Pf. (For \*, when C<sub>L</sub> = 10Pf)

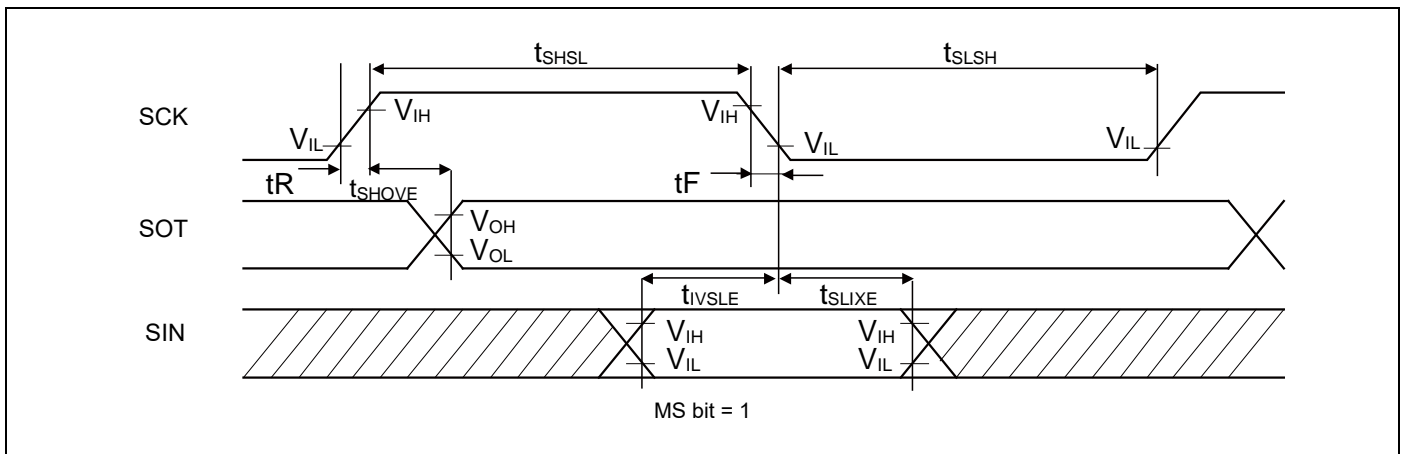
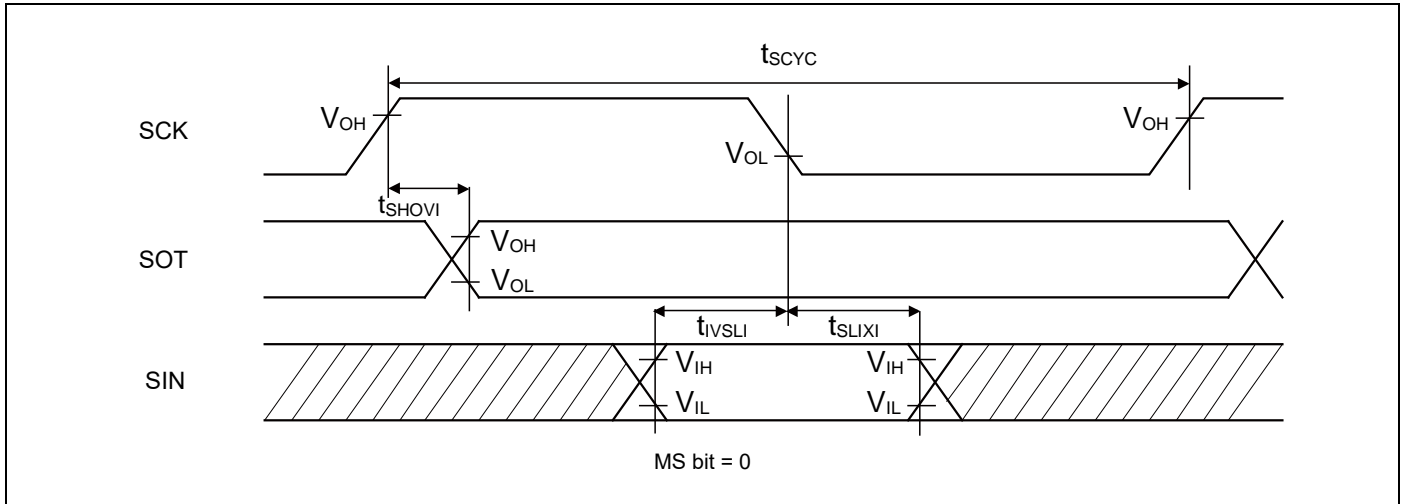

## High-speed synchronous serial (SPI = 1, SCINV = 0)

(V<sub>CC</sub> = 2.7V to 5.5V, V<sub>SS</sub> = 0V)

Parameter	Symbol	Pin name	Conditions	V <sub>CC</sub> < 4.5V		V <sub>CC</sub> ≥ 4.5V		Unit
				Min	Max	Min	Max	
Serial clock cycle time	t <sub>SCYC</sub>	SCKx	Internal shift clock operation	4t <sub>CYCP</sub>	-	4t <sub>CYCP</sub>	-	ns
SCK↑→SOT delay time	t <sub>SHOVI</sub>	SCKx, SOTx		-10	+10	-10	+10	ns
SIN→SCK↓ setup time	t <sub>IVSLI</sub>	SCKx, SINx		14	-	12.5	-	ns
				12.5*				
SCK↓→SIN hold time	t <sub>SLIXI</sub>	SCKx, SINx		5	-	5	-	ns
SOT→SCK↓ delay time	t <sub>SOVLI</sub>	SCKx, SOTx	2t <sub>CYCP</sub> - 10	-	2t <sub>CYCP</sub> - 10	-	ns	
Serial clock "L" pulse width	t <sub>SLSH</sub>	SCKx	External shift clock operation	2t <sub>CYCP</sub> - 5	-	2t <sub>CYCP</sub> - 5	-	ns
Serial clock "H" pulse width	t <sub>SHSL</sub>	SCKx		t <sub>CYCP</sub> + 10	-	t <sub>CYCP</sub> + 10	-	ns
SCK↑→SOT delay time	t <sub>SHOVE</sub>	SCKx, SOTx		-	15	-	15	ns
SIN→SCK↓ setup time	t <sub>IVSLE</sub>	SCKx, SINx		5	-	5	-	ns
SCK↓→SIN hold time	t <sub>SLIXE</sub>	SCKx, SINx		5	-	5	-	ns
SCK falling time	T <sub>f</sub>	SCKx		-	5	-	5	ns
SCK rising time	T <sub>r</sub>	SCKx		-	5	-	5	ns

### Notes:

- The above characteristics apply to CLK synchronous mode.
- t<sub>CYCP</sub> indicates the APB bus clock cycle time.  
About the APB bus number which UART is connected to, see "Block Diagram" in this datasheet.
- These characteristics only guarantee the following pins.
  - No chip select: SIN4\_1, SOT4\_1, SCK4\_1
  - Chip select: SIN6\_1, SOT6\_1, SCK6\_1, SCS6\_1
- When the external load capacitance C<sub>L</sub> = 30Pf. (For \*, when C<sub>L</sub> = 10Pf)

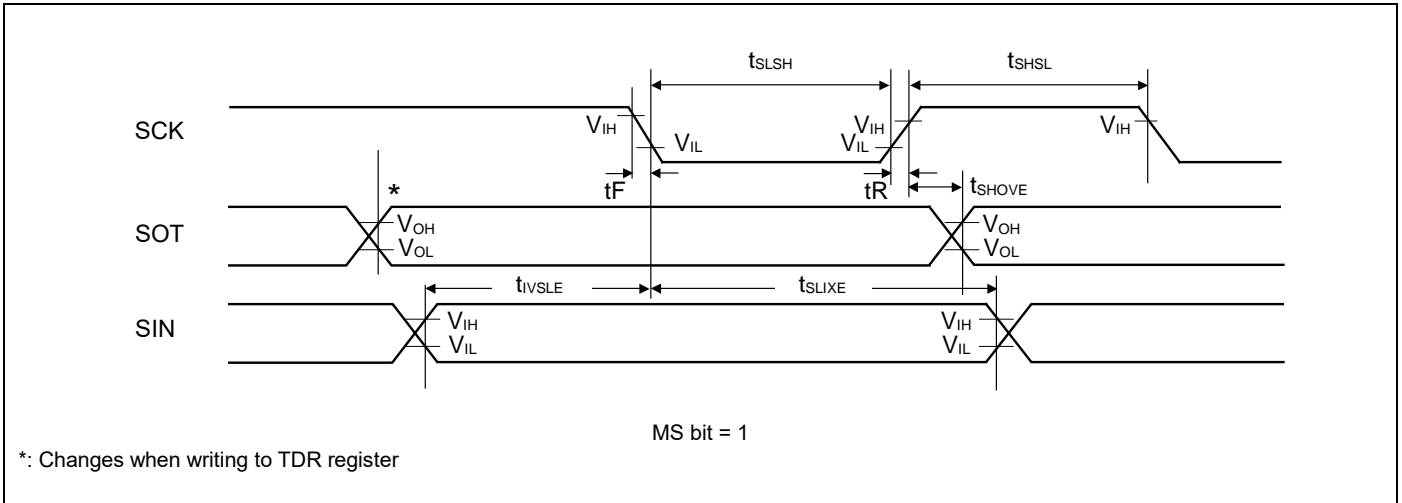
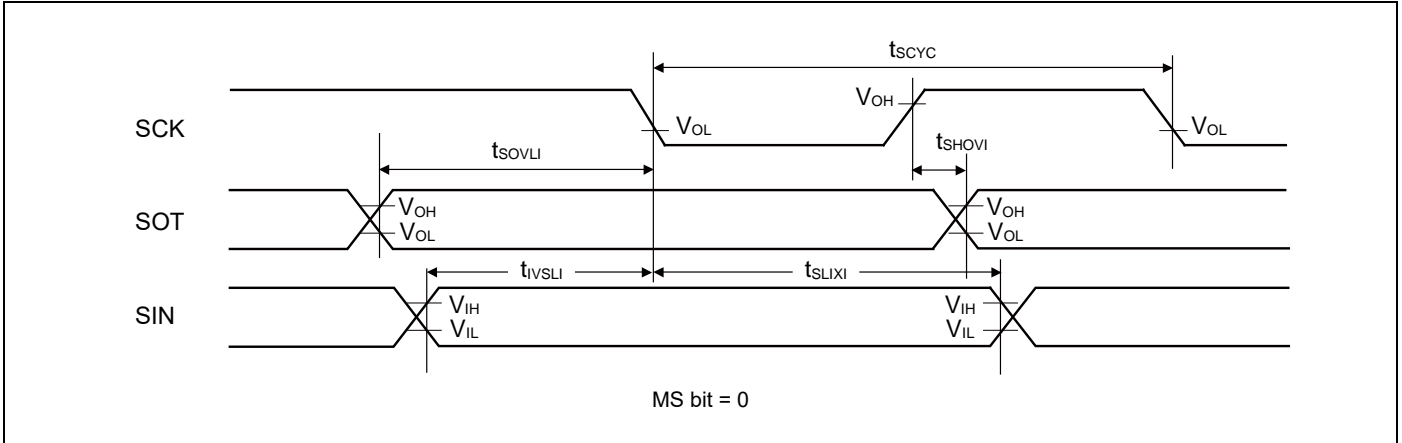

**High-speed synchronous serial (SPI = 1, SCINV = 1)**

 (V<sub>CC</sub> = 2.7V to 5.5V, V<sub>SS</sub> = 0V)

Parameter	Symbol	Pin name	Conditions	V <sub>CC</sub> < 4.5V		V <sub>CC</sub> ≥ 4.5V		Unit
				Min	Max	Min	Max	
Internal shift clock operation	t <sub>SCYC</sub>	SCKx	Internal shift clock operation	4t <sub>CYCP</sub>	-	4t <sub>CYCP</sub>	-	ns
SCK↓→SOT delay time	t <sub>SLOVI</sub>	SCKx, SOTx		-10	+10	-10	+10	ns
SIN→SCK↑ setup time	t <sub>IVSHI</sub>	SCKx, SINx		14	-	12.5	-	ns
				12.5*				
SCK↑→SIN hold time	t <sub>SHIXI</sub>	SCKx, SINx		5	-	5	-	ns
SOT→SCK↑ delay time	t <sub>SOVHI</sub>	SCKx, SOTx	2t <sub>CYCP</sub> - 10	-	2t <sub>CYCP</sub> - 10	-	ns	
Serial clock "L" pulse width	t <sub>SLSH</sub>	SCKx	External shift clock operation	2t <sub>CYCP</sub> - 5	-	2t <sub>CYCP</sub> - 5	-	ns
Serial clock "H" pulse width	t <sub>SHSL</sub>	SCKx		t <sub>CYCP</sub> + 10	-	t <sub>CYCP</sub> + 10	-	ns
SCK↓→SOT delay time	t <sub>SLOVE</sub>	SCKx, SOTx		-	15	-	15	ns
SIN→SCK↑ setup time	t <sub>IVSHE</sub>	SCKx, SINx		5	-	5	-	ns
SCK↑→SIN hold time	t <sub>SHIXE</sub>	SCKx, SINx		5	-	5	-	ns
SCK falling time	T <sub>f</sub>	SCKx		-	5	-	5	ns
SCK rising time	T <sub>r</sub>	SCKx		-	5	-	5	ns

**Notes:**

- The above characteristics apply to CLK synchronous mode.
- t<sub>CYCP</sub> indicates the APB bus clock cycle time.  
About the APB bus number which UART is connected to, see "Block Diagram" in this datasheet.
- These characteristics only guarantee the following pins.
  - No chip select: SIN4\_1, SOT4\_1, SCK4\_1
  - Chip select: SIN6\_1, SOT6\_1, SCK6\_1, SCS6\_1
- When the external load capacitance C<sub>L</sub> = 30Pf. (For \*, when C<sub>L</sub> = 10Pf)

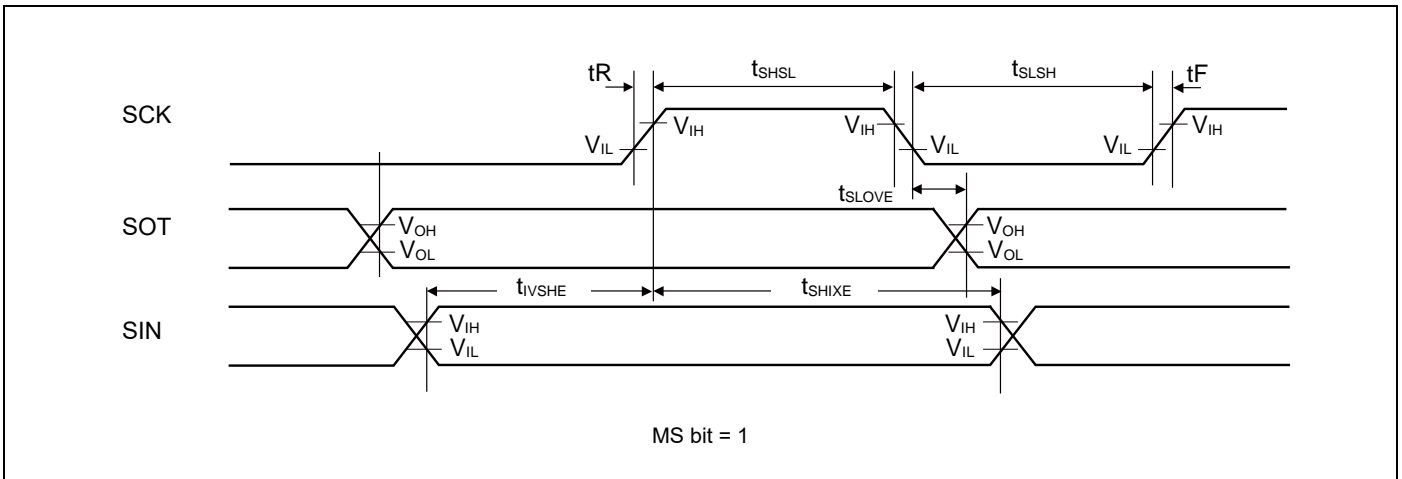
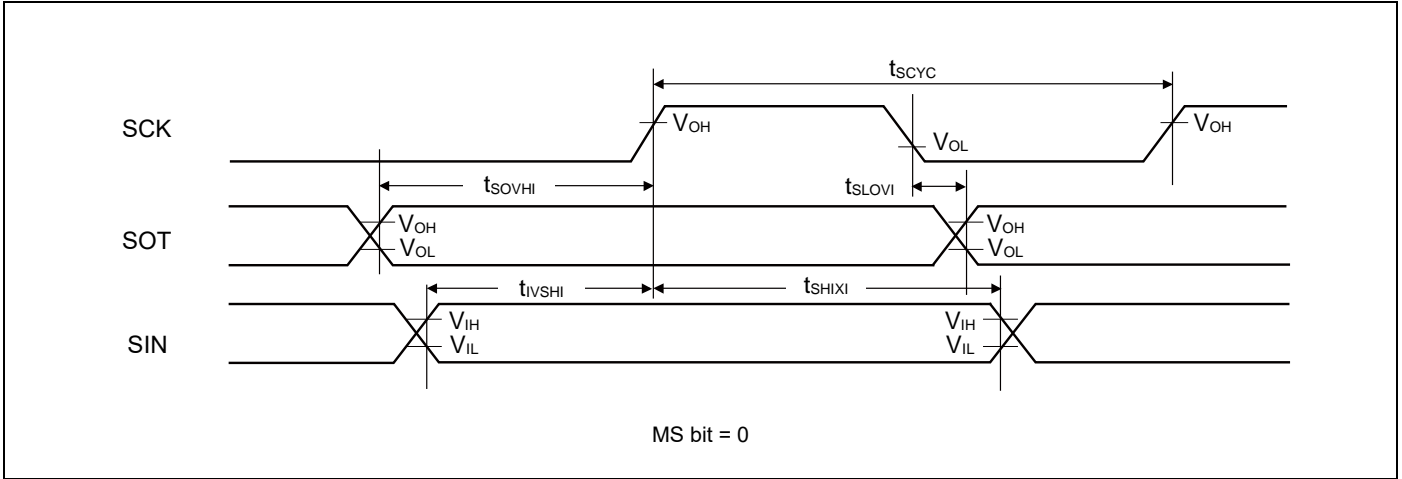

## When using high-speed synchronous serial chip select (SCINV = 0, CSLVL = 1)

(V<sub>CC</sub> = 2.7V to 5.5V, V<sub>SS</sub> = 0V)

Parameter	Symbol	Conditions	V <sub>CC</sub> < 4.5V		V <sub>CC</sub> ≥ 4.5V		Unit
			Min	Max	Min	Max	
SCS↓→SCK↓setup time	t <sub>CSSI</sub>	Internal shift clock operation	(*1)-20	(*1)+0	(*1)-20	(*1)+0	ns
SCK↑→SCS↑ hold time	t <sub>CShI</sub>		(*2)+0	(*2)+20	(*2)+0	(*2)+20	ns
SCS deselect time	t <sub>CSDI</sub>		(*3)-20 +5t <sub>CYCP</sub>	(*3)+20 +5t <sub>CYCP</sub>	(*3)-20 +5t <sub>CYCP</sub>	(*3)+20 +5t <sub>CYCP</sub>	ns
SCS↓→SCK↓setup time	t <sub>CSSe</sub>	External shift clock operation	3t <sub>CYCP</sub> +15	-	3t <sub>CYCP</sub> +15	-	ns
SCK↑→SCS↑ hold time	t <sub>CShE</sub>		0	-	0	-	ns
SCS deselect time	t <sub>CSDe</sub>		3t <sub>CYCP</sub> +15	-	3t <sub>CYCP</sub> +15	-	ns
SCS↓→SOT delay time	t <sub>DSE</sub>		-	25	-	25	ns
SCS↑→SOT delay time	t <sub>DEE</sub>		0	-	0	-	ns

(\*1): CSSU bit value×serial chip select timing operating clock cycle [ns]

(\*2): CSHD bit value×serial chip select timing operating clock cycle [ns]

(\*3): CSDS bit value×serial chip select timing operating clock cycle [ns]

### Notes:

- t<sub>CYCP</sub> indicates the APB bus clock cycle time.  
About the APB bus number which UART is connected to, see “Block Diagram” in this datasheet.
- About CSSU, CSHD, CSDS, serial chip select timing operating clock, see “FM4 Family Peripheral Manual”.
- When the external load capacitance C<sub>L</sub> = 30Pf.

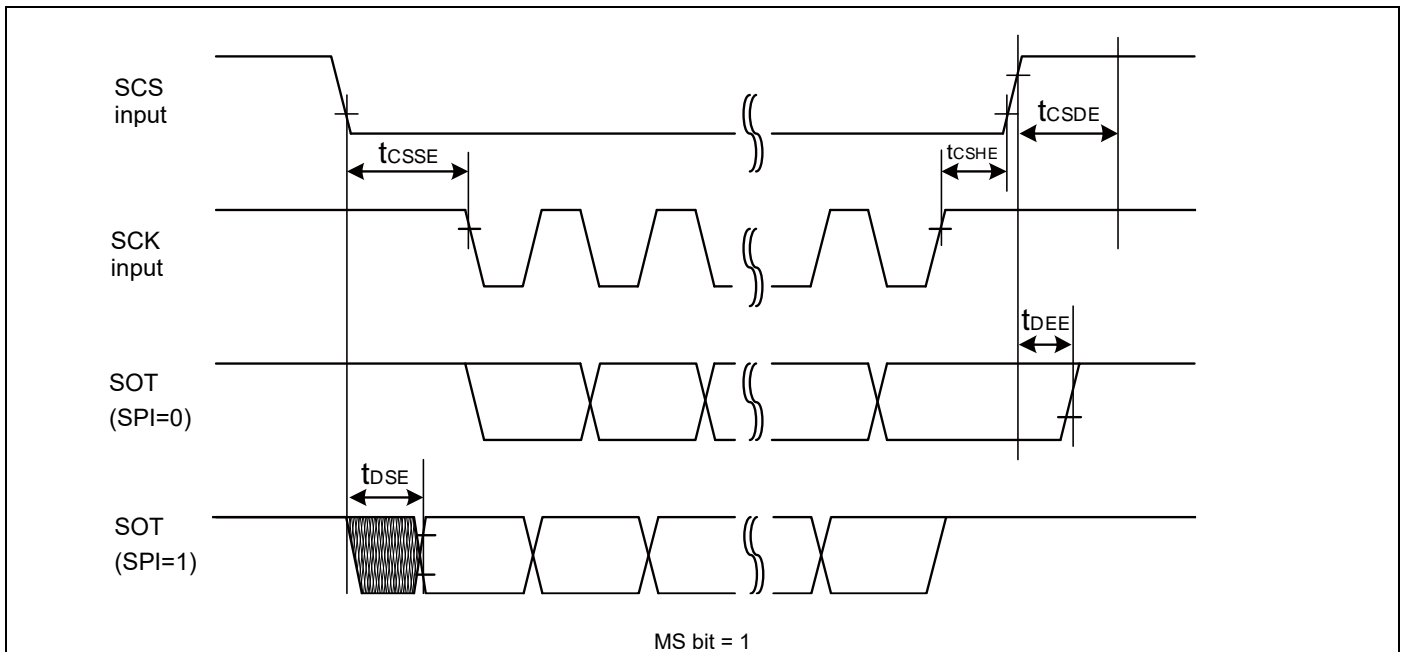
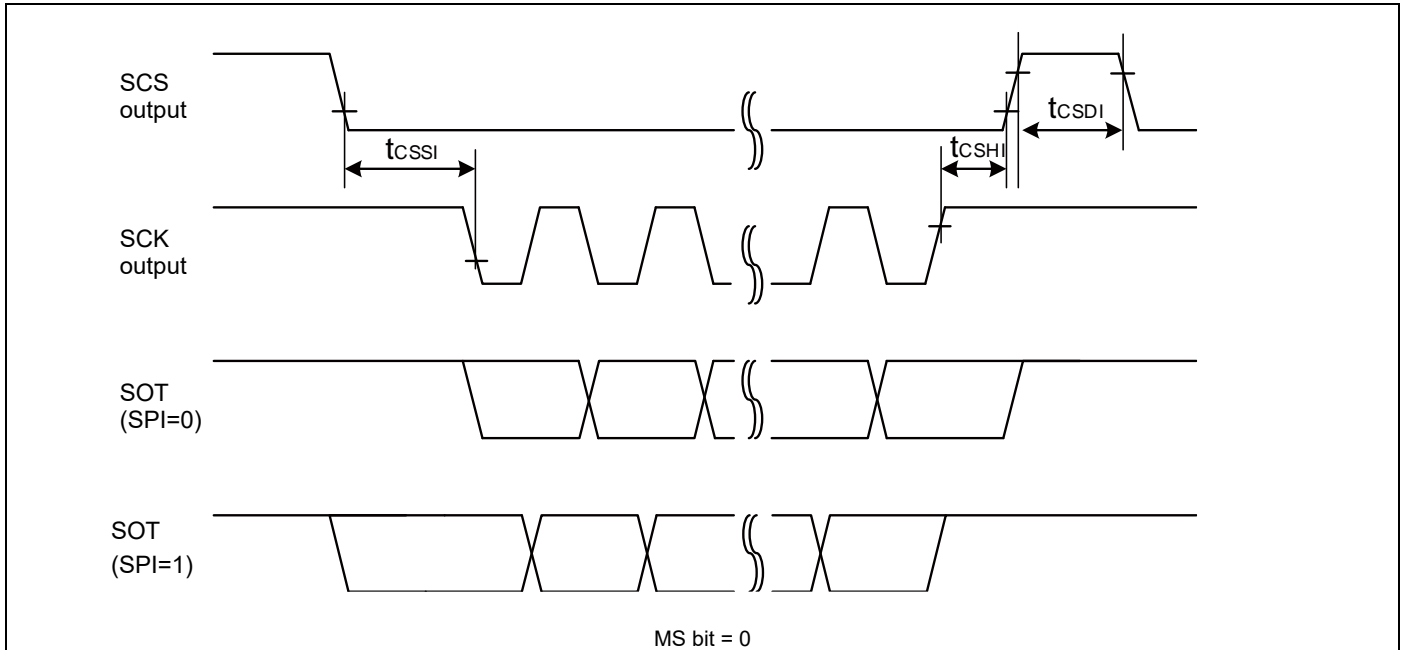

## When using high-speed synchronous serial chip select (SCINV = 1, CSLVL = 1)

(V<sub>CC</sub> = 2.7V to 5.5V, V<sub>SS</sub> = 0V)

Parameter	Symbol	Conditions	V <sub>CC</sub> < 4.5V		V <sub>CC</sub> ≥ 4.5V		Unit
			Min	Max	Min	Max	
SCS↓→SCK↑setup time	t <sub>CSSI</sub>	Internal shift clock operation	(*1)-20	(*1)+0	(*1)-20	(*1)+0	ns
SCK↓→SCS↑ hold time	t <sub>CSHI</sub>		(*2)+0	(*2)+20	(*2)+0	(*2)+20	ns
SCS deselect time	t <sub>CSDI</sub>		(*3)-20 +5t <sub>CYCP</sub>	(*3)+20 +5t <sub>CYCP</sub>	(*3)-20 +5t <sub>CYCP</sub>	(*3)+20 +5t <sub>CYCP</sub>	ns
SCS↓→SCK↑setup time	t <sub>CSSE</sub>	External shift clock operation	3t <sub>CYCP</sub> +15	-	3t <sub>CYCP</sub> +15	-	ns
SCK↓→SCS↑ hold time	t <sub>CSHE</sub>		0	-	0	-	ns
SCS deselect time	t <sub>CSDE</sub>		3t <sub>CYCP</sub> +15	-	3t <sub>CYCP</sub> +15	-	ns
SCS↓→SOT delay time	t <sub>DSE</sub>		-	25	-	25	ns
SCS↑→SOT delay time	t <sub>DEE</sub>		0	-	0	-	ns

(\*1): CSSU bit value×serial chip select timing operating clock cycle [ns]

(\*2): CSHD bit value×serial chip select timing operating clock cycle [ns]

(\*3): CSDS bit value×serial chip select timing operating clock cycle [ns]

### Notes:

- t<sub>CYCP</sub> indicates the APB bus clock cycle time.  
About the APB bus number which UART is connected to, see “Block Diagram” in this datasheet.
- About CSSU, CSHD, CSDS, serial chip select timing operating clock, see “FM4 Family Peripheral Manual”.
- When the external load capacitance C<sub>L</sub> = 30Pf.

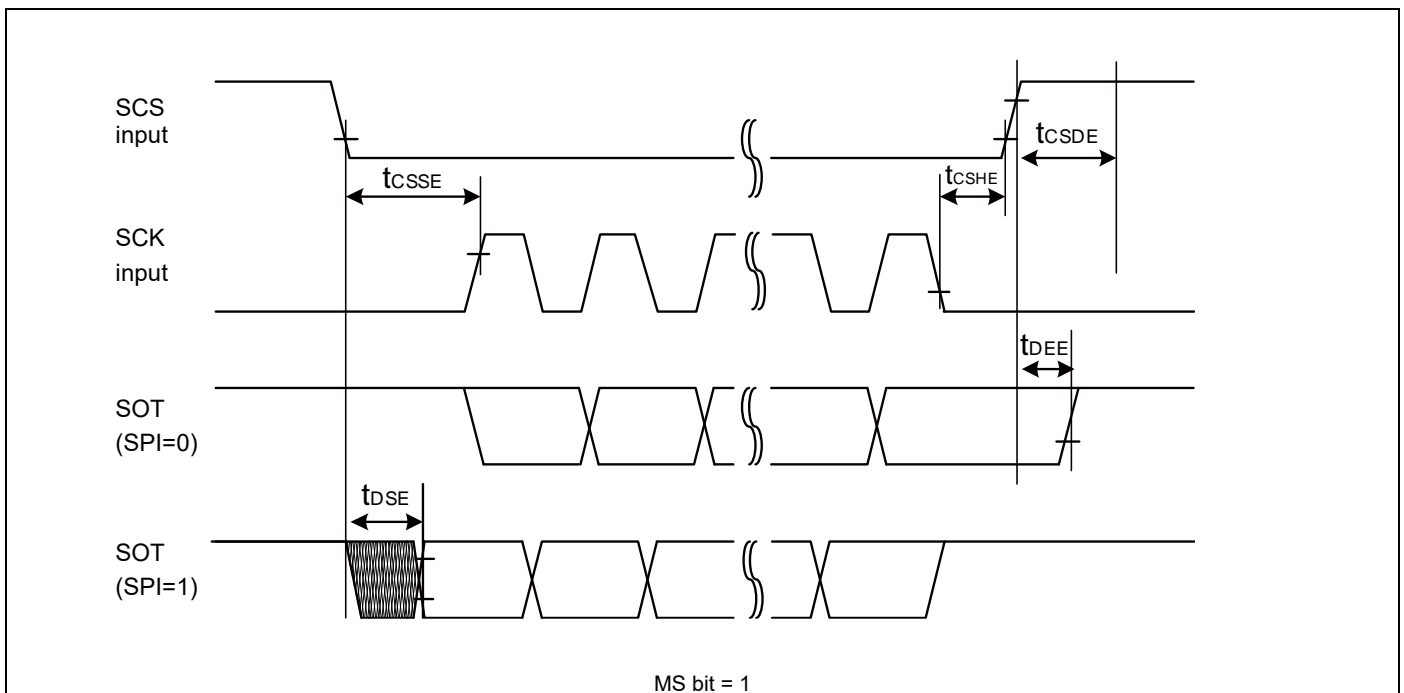
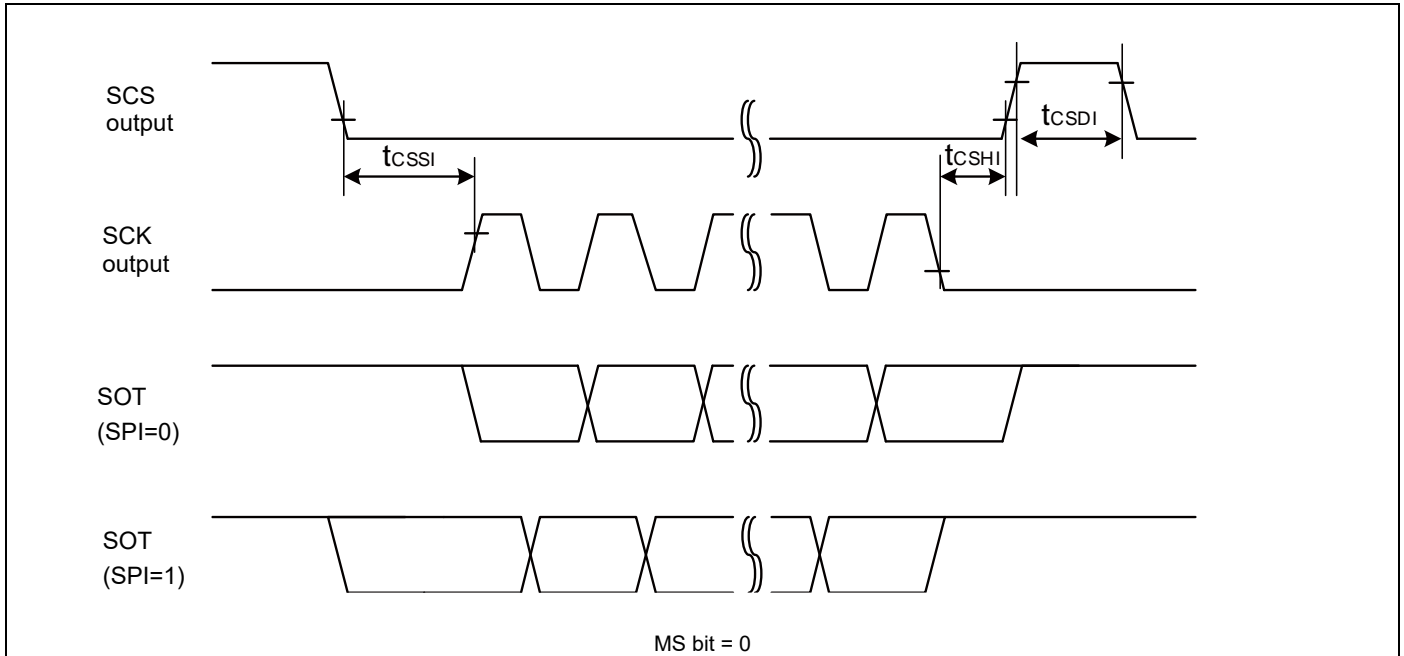

## When using high-speed synchronous serial chip select (SCINV = 0, CSLVL = 0)

(V<sub>CC</sub> = 2.7V to 5.5V, V<sub>SS</sub> = 0V)

Parameter	Symbol	Conditions	V <sub>CC</sub> < 4.5V		V <sub>CC</sub> ≥ 4.5V		Unit
			Min	Max	Min	Max	
SCS↑→SCK↓ setup time	t <sub>CSSI</sub>	Internal shift clock operation	(*1)-20	(*1)+0	(*1)-20	(*1)+0	ns
SCK↑→SCS↓ hold time	t <sub>CSHI</sub>		(*2)+0	(*2)+20	(*2)+0	(*2)+20	ns
SCS deselect time	t <sub>CSDI</sub>		(*3)-20 +5t <sub>CYCP</sub>	(*3)+20 +5t <sub>CYCP</sub>	(*3)-20 +5t <sub>CYCP</sub>	(*3)+20 +5t <sub>CYCP</sub>	ns
SCS↑→SCK↓ setup time	t <sub>CSSE</sub>	External shift clock operation	3t <sub>CYCP</sub> +15	-	3t <sub>CYCP</sub> +15	-	ns
SCK↑→SCS↓ hold time	t <sub>CSHE</sub>		0	-	0	-	ns
SCS deselect time	t <sub>CSDE</sub>		3t <sub>CYCP</sub> +15	-	3t <sub>CYCP</sub> +15	-	ns
SCS↑→SOT delay time	t <sub>DSE</sub>		-	25	-	25	ns
SCS↓→SOT delay time	t <sub>DEE</sub>		0	-	0	-	ns

(\*1): CSSU bit value×serial chip select timing operating clock cycle [ns]

(\*2): CSHD bit value×serial chip select timing operating clock cycle [ns]

(\*3): CSDS bit value×serial chip select timing operating clock cycle [ns]

### Notes:

- t<sub>CYCP</sub> indicates the APB bus clock cycle time.  
About the APB bus number which UART is connected to, see “Block Diagram” in this datasheet.
- About CSSU, CSHD, CSDS, serial chip select timing operating clock, see “FM4 Family Peripheral Manual”.
- When the external load capacitance C<sub>L</sub> = 30Pf.

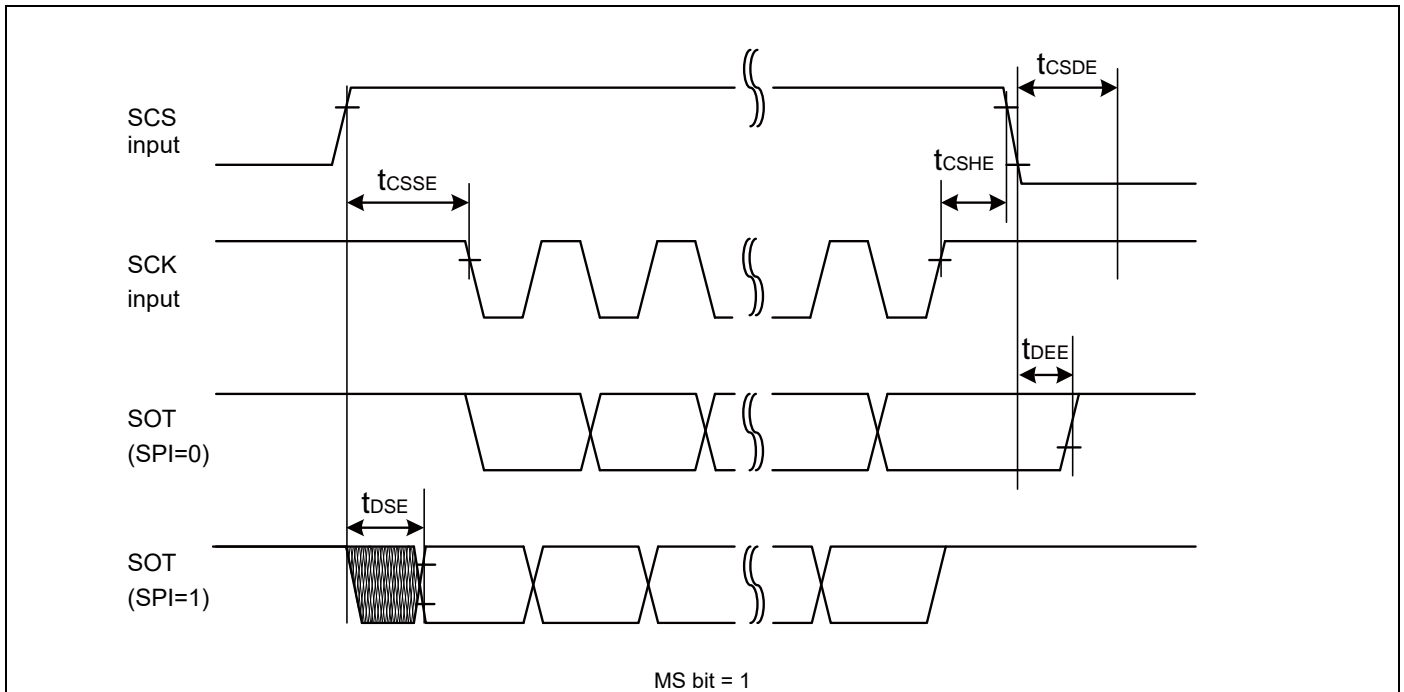
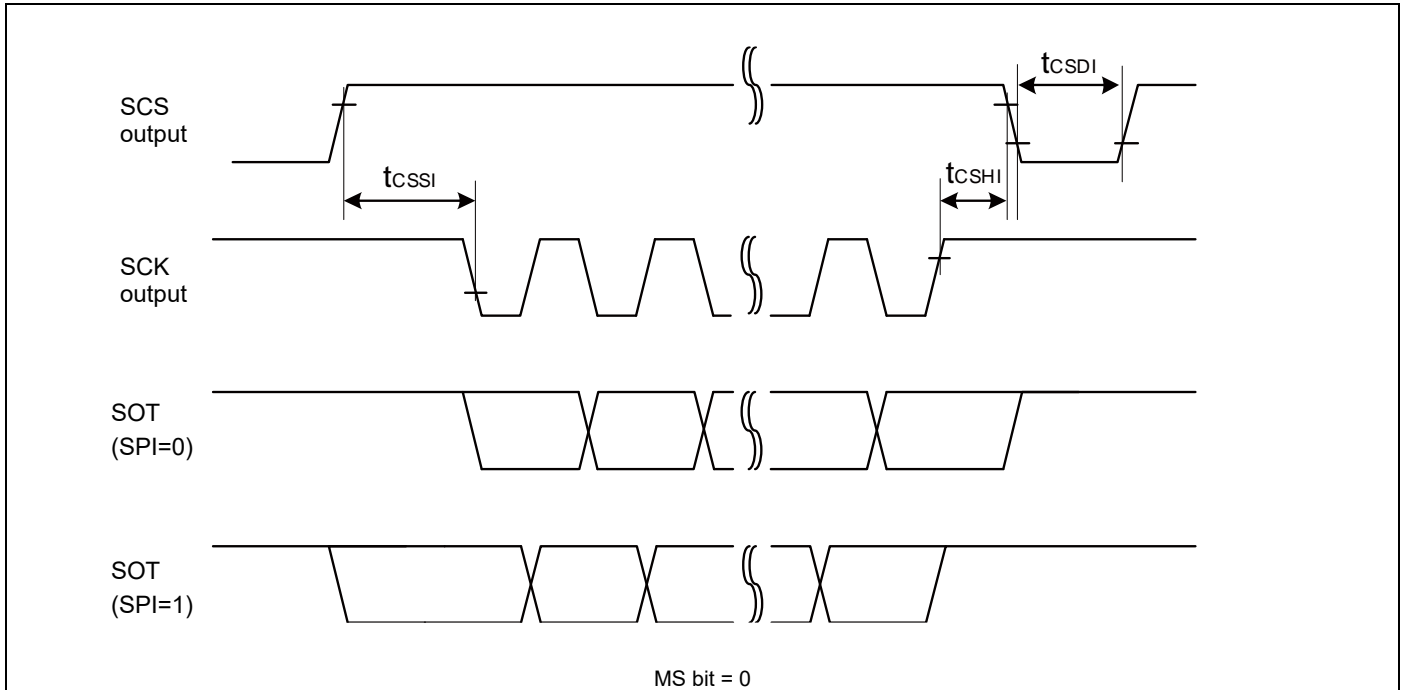

## When using high-speed synchronous serial chip select (SCINV = 1, CSLVL = 0)

(V<sub>CC</sub> = 2.7V to 5.5V, V<sub>SS</sub> = 0V)

Parameter	Symbol	Conditions	V <sub>CC</sub> < 4.5V		V <sub>CC</sub> ≥ 4.5V		Unit
			Min	Max	Min	Max	
SCS↑→SCK↑setup time	t <sub>CSSI</sub>	Internal shift clock operation	(*1)-20	(*1)+0	(*1)-20	(*1)+0	ns
SCK↓→SCS↓ hold time	t <sub>CShI</sub>		(*2)+0	(*2)+20	(*2)+0	(*2)+20	ns
SCS deselect time	t <sub>CSDI</sub>		(*3)-20 +5t <sub>CYCP</sub>	(*3)+20 +5t <sub>CYCP</sub>	(*3)-20 +5t <sub>CYCP</sub>	(*3)+20 +5t <sub>CYCP</sub>	ns
SCS↑→SCK↑setup time	t <sub>CSSe</sub>	External shift clock operation	3t <sub>CYCP</sub> +15	-	3t <sub>CYCP</sub> +15	-	ns
SCK↓→SCS↓ hold time	t <sub>CShE</sub>		0	-	0	-	ns
SCS deselect time	t <sub>CSDe</sub>		3t <sub>CYCP</sub> +15	-	3t <sub>CYCP</sub> +15	-	ns
SCS↑→SOT delay time	t <sub>DSE</sub>		-	25	-	25	ns
SCS↓→SOT delay time	t <sub>DEE</sub>		0	-	0	-	ns

(\*1): CSSU bit value×serial chip select timing operating clock cycle [ns]

(\*2): CSHD bit value×serial chip select timing operating clock cycle [ns]

(\*3): CSDS bit value×serial chip select timing operating clock cycle [ns]

### Notes:

- t<sub>CYCP</sub> indicates the APB bus clock cycle time.  
About the APB bus number which UART is connected to, see "Block Diagram" in this datasheet.
- About CSSU, CSHD, CSDS, serial chip select timing operating clock, see "FM4 Family Peripheral Manual".
- When the external load capacitance C<sub>L</sub> = 30Pf.

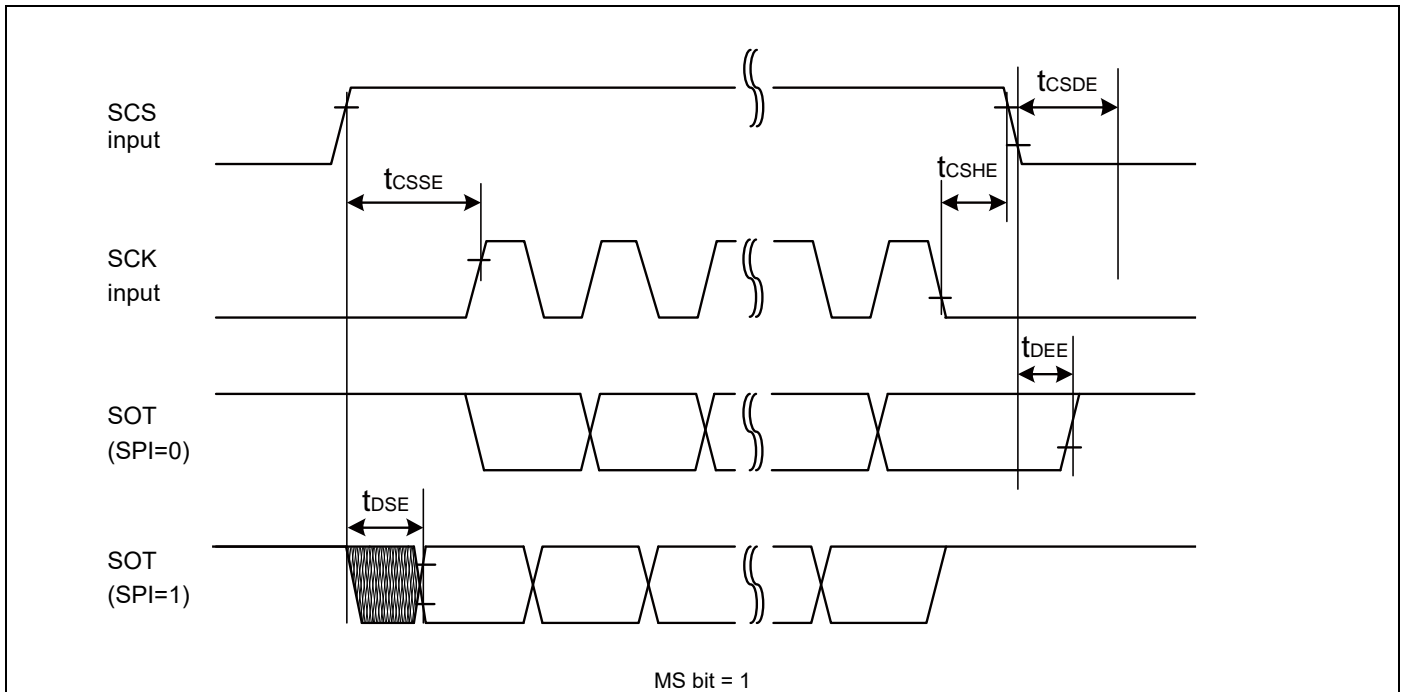
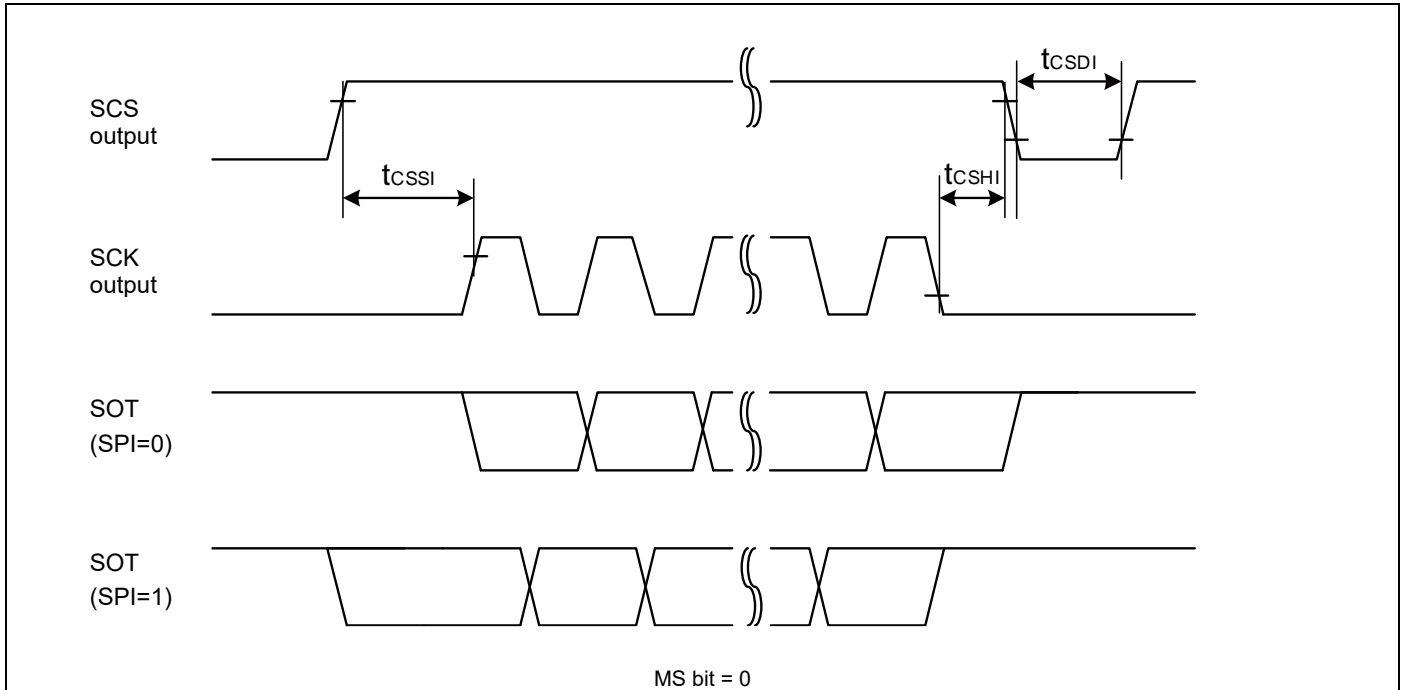

**External clock (EXT = 1) : when in asynchronous mode only**

(V<sub>CC</sub> = 2.7V to 5.5V, V<sub>SS</sub> = 0V)

Parameter	Symbol	Condition	Value		Unit	Remarks
			Min	Max		
Serial clock "L" pulse width	t <sub>SLSH</sub>	C <sub>L</sub> = 30Pf	t <sub>CYCP</sub> + 10	-	ns	
Serial clock "H" pulse width	t <sub>SHSL</sub>		t <sub>CYCP</sub> + 10	-	ns	
SCK falling time	T <sub>f</sub>		-	5	ns	
SCK rising time	T <sub>r</sub>		-	5	ns	

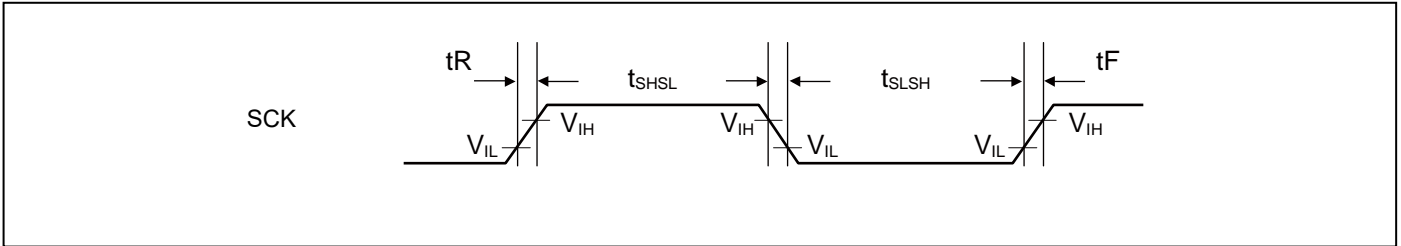

**12.4.12 External Input Timing**

(V<sub>CC</sub> = 2.7V to 5.5V, V<sub>SS</sub> = 0V)

Parameter	Symbol	Pin name	Conditions	Value		Unit	Remarks
				Min	Max		
Input pulse width	t <sub>INH</sub> , t <sub>INL</sub>	ADTG	-	2t <sub>CYCP</sub> *1	-	ns	A/D converter trigger input
		FRCKx	-		Free-run timer input clock		
		ICXX	-		Input capture		
		DTTIXX	-	2t <sub>CYCP</sub> *1	-	ns	Waveform generator
		INT00 to INT31, NMIX	-	2t <sub>CYCP</sub> + 100*1	-	ns	External interrupt, NMI
		WKUPx	-	500*2	-	ns	NMI
				500*3	-	ns	Deep standby wake up

\*1: t<sub>CYCP</sub> indicates the APB bus clock cycle time except stop when in STOP mode, in timer mode.  
About the APB bus number which the A/D converter, Multi-function Timer, External interrupt are connected to, see "Block Diagram" in this data sheet.

\*2: When in STOP mode, in timer mode.

\*3: When in deep standby RTC mode, in deep standby STOP mode.

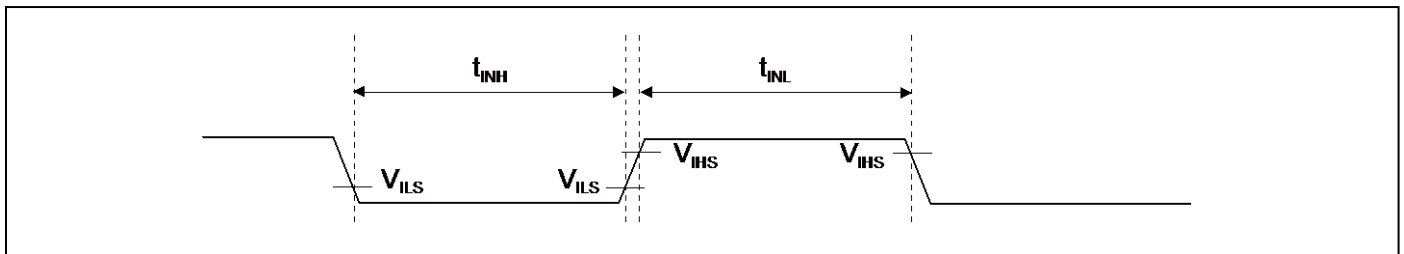

**12.4.13 Quadrature Position/Revolution Counter Timing**

 (V<sub>CC</sub> = 2.7V to 5.5V, V<sub>SS</sub> = 0V)

Parameter	Symbol	Conditions	Value		Unit
			Min	Max	
AIN pin "H" width	t <sub>AHL</sub>	-	2t <sub>CYCP</sub> *	-	ns
AIN pin "L" width	t <sub>ALL</sub>	-			
BIN pin "H" width	t <sub>BHL</sub>	-			
BIN pin "L" width	t <sub>BLL</sub>	-			
BIN rising time from AIN pin "H" level	t <sub>AUBU</sub>	PC_Mode2 or PC_Mode3			
AIN falling time from BIN pin "H" level	t <sub>BUAD</sub>	PC_Mode2 or PC_Mode3			
BIN falling time from AIN pin "L" level	t <sub>ADBD</sub>	PC_Mode2 or PC_Mode3			
AIN rising time from BIN pin "L" level	t <sub>BDAU</sub>	PC_Mode2 or PC_Mode3			
AIN rising time from BIN pin "H" level	t <sub>BUAU</sub>	PC_Mode2 or PC_Mode3			
BIN falling time from AIN pin "H" level	t <sub>AUBD</sub>	PC_Mode2 or PC_Mode3			
AIN falling time from BIN pin "L" level	t <sub>BDAD</sub>	PC_Mode2 or PC_Mode3			
BIN rising time from AIN pin "L" level	t <sub>ADBU</sub>	PC_Mode2 or PC_Mode3			
ZIN pin "H" width	t <sub>ZHL</sub>	QCR:CGSC = "0"			
ZIN pin "L" width	t <sub>ZLL</sub>	QCR:CGSC = "0"			
AIN/BIN rising and falling time from determined ZIN level	t <sub>ZABE</sub>	QCR:CGSC = "1"			
Determined ZIN level from AIN/BIN rising and falling time	t <sub>ABEZ</sub>	QCR:CGSC = "1"			

\*: t<sub>CYCP</sub> indicates the APB bus clock cycle time except stop when in STOP mode, in timer mode. About the APB bus number which Quadrature Position/Revolution Counter is connected to, see "Block Diagram" in this data sheet.

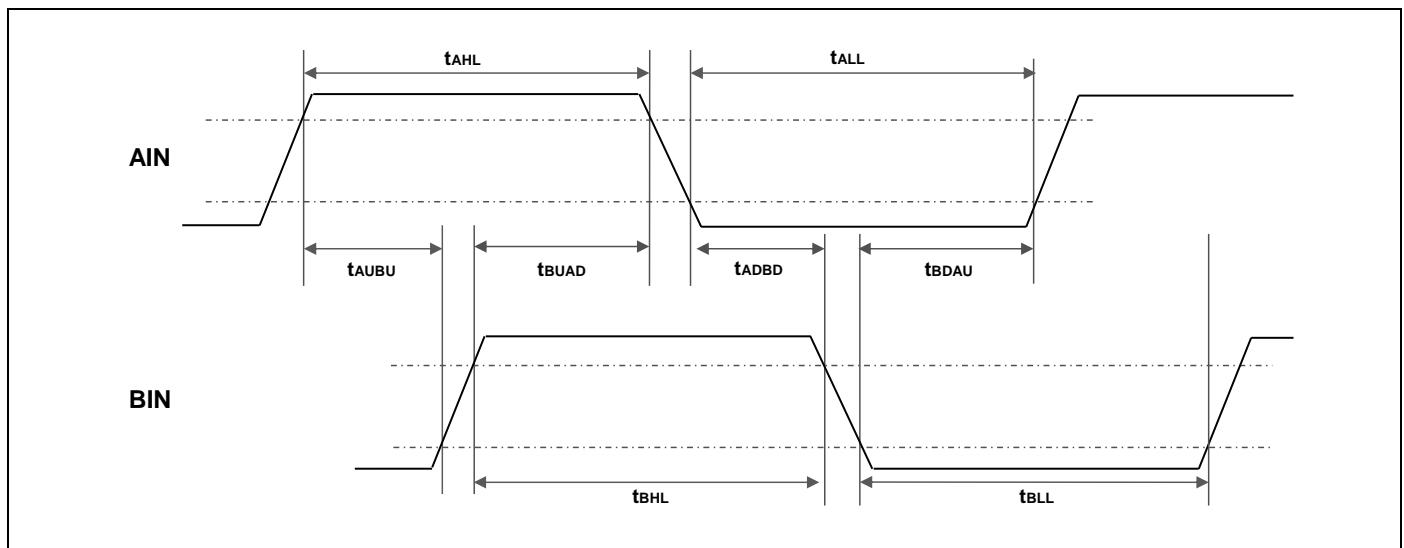

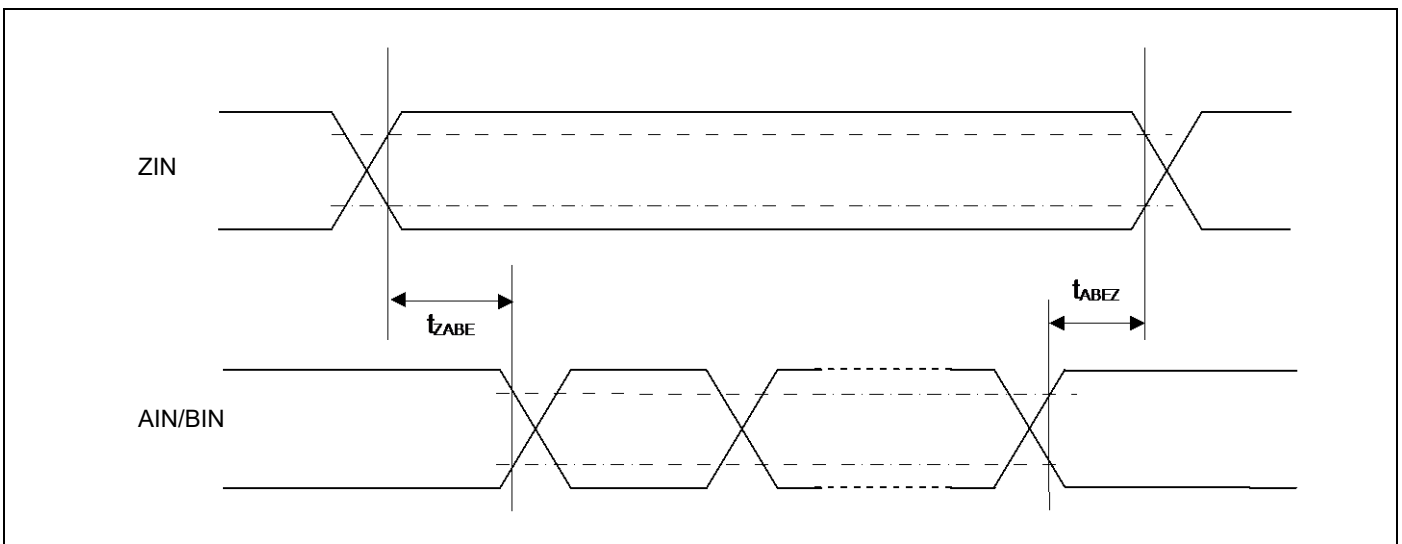
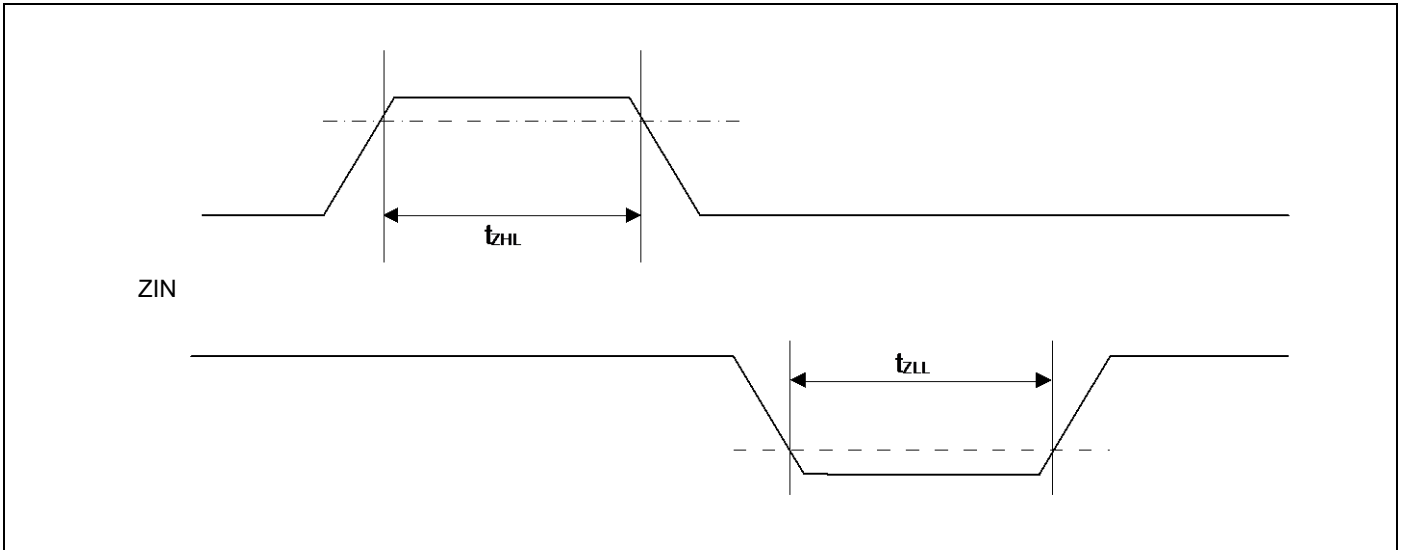
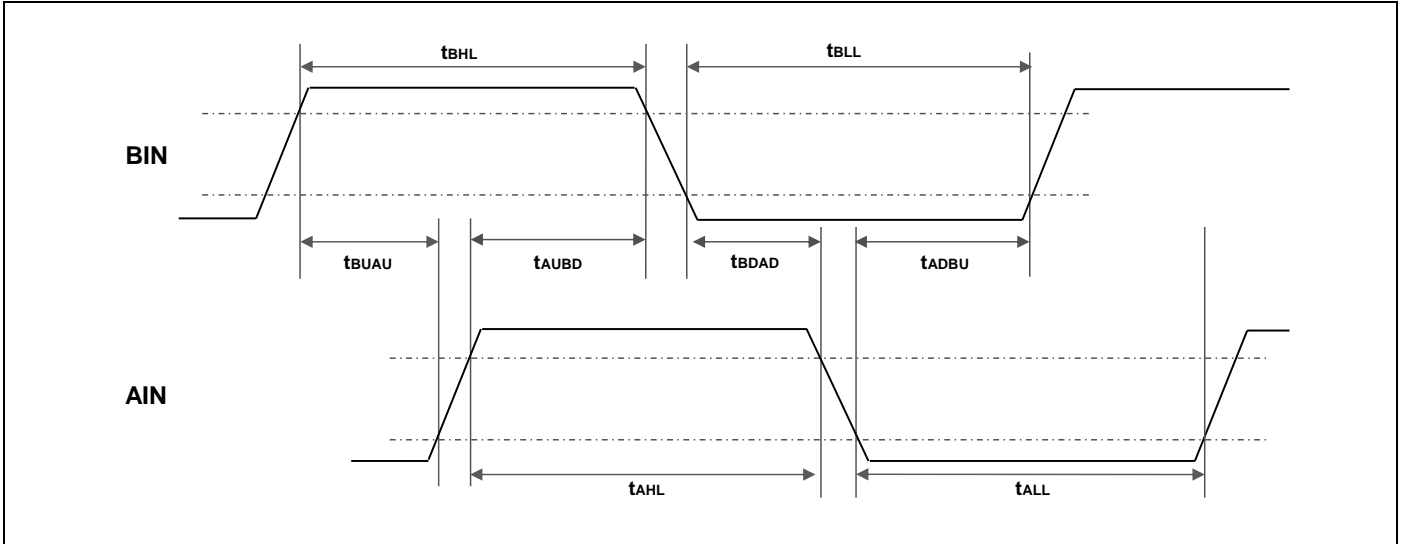

**12.4.14 I<sup>2</sup>C Timing**
**Standard-mode, Fast-mode**

 (V<sub>CC</sub> = 2.7V to 5.5V, V<sub>SS</sub> = 0V)

Parameter	Symbol	Conditions	Standard-mode		Fast-mode		Unit	Remarks
			Min	Max	Min	Max		
SCL clock frequency	F <sub>SCL</sub>	C <sub>L</sub> = 30Pf, R = (V <sub>p</sub> /I <sub>OL</sub> )* <sup>1</sup>	0	100	0	400	kHz	
(Repeated) START condition hold time SDA ↓ → SCL ↓	t <sub>HDSTA</sub>		4.0	-	0.6	-	μs	
SCL clock "L" width	t <sub>LOW</sub>		4.7	-	1.3	-	μs	
SCL clock "H" width	t <sub>HIGH</sub>		4.0	-	0.6	-	μs	
(Repeated) START condition setup time SCL ↑ → SDA ↓	t <sub>SUSTA</sub>		4.7	-	0.6	-	μs	
Data hold time SCL ↓ → SDA ↓ ↑	t <sub>HDDAT</sub>		0	3.45* <sup>2</sup>	0	0.9* <sup>3</sup>	μs	
Data setup time SDA ↓ ↑ → SCL ↑	t <sub>SUDAT</sub>		250	-	100	-	ns	
STOP condition setup time SCL ↑ → SDA ↑	t <sub>SUSTO</sub>		4.0	-	0.6	-	μs	
Bus free time between "STOP condition" and "START condition"	t <sub>BUF</sub>		4.7	-	1.3	-	μs	
Noise filter	t <sub>SP</sub>	2MHz ≤ t <sub>CYCP</sub> < 40MHz	2t <sub>CYCP</sub> * <sup>4</sup>	-	2t <sub>CYCP</sub> * <sup>4</sup>	-	ns	*5
		40MHz ≤ t <sub>CYCP</sub> < 60MHz	4t <sub>CYCP</sub> * <sup>4</sup>	-	4t <sub>CYCP</sub> * <sup>4</sup>	-	ns	
		60MHz ≤ t <sub>CYCP</sub> < 80MHz	6t <sub>CYCP</sub> * <sup>4</sup>	-	6t <sub>CYCP</sub> * <sup>4</sup>	-	ns	
		80MHz ≤ t <sub>CYCP</sub> < 100MHz	8t <sub>CYCP</sub> * <sup>4</sup>	-	8t <sub>CYCP</sub> * <sup>4</sup>	-	ns	
		100MHz ≤ t <sub>CYCP</sub> < 120MHz	10t <sub>CYCP</sub> * <sup>4</sup>	-	10t <sub>CYCP</sub> * <sup>4</sup>	-	ns	
		120MHz ≤ t <sub>CYCP</sub> < 140MHz	12t <sub>CYCP</sub> * <sup>4</sup>	-	12t <sub>CYCP</sub> * <sup>4</sup>	-	ns	
		140MHz ≤ t <sub>CYCP</sub> < 160MHz	14t <sub>CYCP</sub> * <sup>4</sup>	-	14t <sub>CYCP</sub> * <sup>4</sup>	-	ns	
		160MHz ≤ t <sub>CYCP</sub> < 180MHz	16t <sub>CYCP</sub> * <sup>4</sup>	-	16t <sub>CYCP</sub> * <sup>4</sup>	-	ns	

\*1: R and C<sub>L</sub> represent the pull-up resistance and load capacitance of the SCL and SDA lines, respectively. V<sub>p</sub> indicates the power supply voltage of the pull-up resistance and I<sub>OL</sub> indicates V<sub>OL</sub> guaranteed current.

\*2: The maximum t<sub>HDDAT</sub> must satisfy that it does not extend at least "L" period (t<sub>LOW</sub>) of device's SCL signal.

\*3: A Fast-mode I<sup>2</sup>C bus device can be used on a Standard-mode I<sup>2</sup>C bus system as long as the device satisfies the requirement of "t<sub>SUDAT</sub> ≥ 250 ns".

\*4: t<sub>CYCP</sub> is the APB bus clock cycle time.

About the APB bus number that I<sup>2</sup>C is connected to, see "Block Diagram" in this data sheet.

\*5: The noise filter time can be changed by register settings.

Change the number of the noise filter steps according to APB bus clock frequency.

## Fast-mode Plus (Fm+)

(V<sub>CC</sub> = 2.7V to 5.5V, V<sub>SS</sub> = 0V)

Parameter	Symbol	Conditions	Fast-mode Plus (Fm+) <sup>*6</sup>		Unit	Remarks
			Min	Max		
SCL clock frequency	F <sub>SCL</sub>		0	1000	kHz	
(Repeated) START condition hold time SDA ↓ → SCL ↓	t <sub>HDSTA</sub>		0.26	-	μs	
SCL clock "L" width	t <sub>LOW</sub>		0.5	-	μs	
SCL clock "H" width	t <sub>HIGH</sub>		0.26	-	μs	
SCL clock frequency	t <sub>SUSTA</sub>		0.26	-	μs	
(Repeated) START condition hold time SDA ↓ → SCL ↓	t <sub>HDDAT</sub>	C <sub>L</sub> = 30Pf, R = (V <sub>p</sub> /I <sub>OL</sub> )* <sup>1</sup>	0	0.45 <sup>*2, *3</sup>	μs	
Data setup time SDA ↓ ↑ → SCL ↑	t <sub>SUDAT</sub>		50	-	ns	
STOP condition setup time SCL ↑ → SDA ↑	t <sub>SUSTO</sub>		0.26	-	μs	
Bus free time between "STOP condition" and "START condition"	t <sub>BUF</sub>		0.5	-	μs	
Noise filter	t <sub>SP</sub>	60MHz ≤ t <sub>CYCP</sub> < 80MHz	6 t <sub>CYCP</sub> <sup>*4</sup>	-	ns	*5
		80MHz ≤ t <sub>CYCP</sub> < 100MHz	8 t <sub>CYCP</sub> <sup>*4</sup>	-	ns	
		100MHz ≤ t <sub>CYCP</sub> < 120MHz	10 t <sub>CYCP</sub> <sup>*4</sup>	-	ns	
		120MHz ≤ t <sub>CYCP</sub> < 140MHz	12 t <sub>CYCP</sub> <sup>*4</sup>	-	ns	
		140MHz ≤ t <sub>CYCP</sub> < 160MHz	14 t <sub>CYCP</sub> <sup>*4</sup>	-	ns	
		160MHz ≤ t <sub>CYCP</sub> < 180MHz	16 t <sub>CYCP</sub> <sup>*4</sup>	-	ns	

- \*1: R and C<sub>L</sub> represent the pull-up resistance and load capacitance of the SCL and SDA lines, respectively. V<sub>p</sub> indicates the power supply voltage of the pull-up resistance and I<sub>OL</sub> indicates V<sub>OL</sub> guaranteed current.
- \*2: The maximum t<sub>HDDAT</sub> must satisfy that it does not extend at least "L" period (t<sub>LOW</sub>) of device's SCL signal.
- \*3: A Fast-mode I<sup>2</sup>C bus device can be used on a Standard-mode I<sup>2</sup>C bus system as long as the device satisfies the requirement of "t<sub>SUDAT</sub> ≥ 250 ns".
- \*4: t<sub>CYCP</sub> is the APB bus clock cycle time.  
About the APB bus number that I<sup>2</sup>C is connected to, see "Block Diagram" in this data sheet.  
To use Fast-mode Plus (Fm+), set the peripheral bus clock at 64 MHz or more.
- \*5: The noise filter time can be changed by register settings.  
Change the number of the noise filter steps according to APB bus clock frequency.
- \*6: When using Fast-mode Plus (Fm+), set the I/O pin to the mode corresponding to I<sup>2</sup>C Fm+ in the EPFR register.  
See "Chapter: I/O Port" in "FM4 Family Peripheral Manual" for the details.

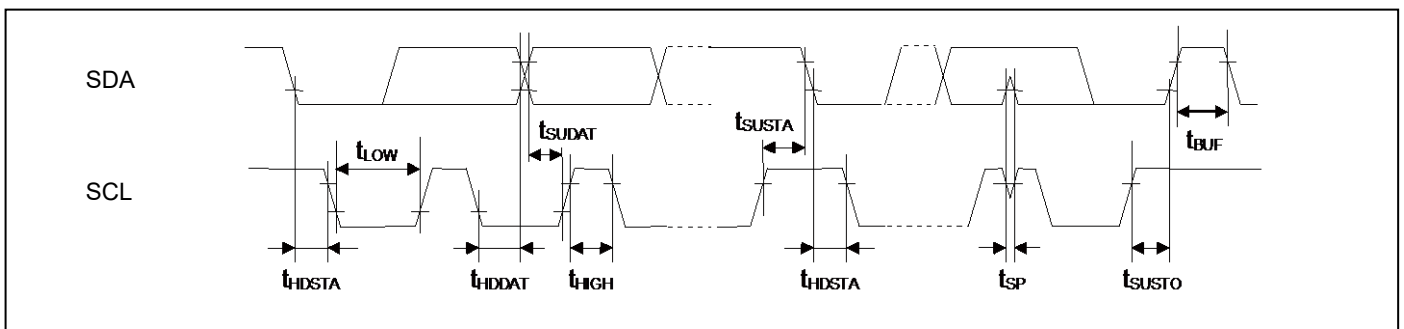

12.4.15 SD Card Interface Timing

Default-Speed Mode

■ Clock CLK (All values are referred to  $V_{IH}$  and  $V_{IL}$ )

( $V_{CC} = 2.7V$  to  $3.6V$ ,  $V_{SS} = 0V$ )

Parameter	Symbol	Pin name	Conditions	Value		Remarks
				Min	Max	
Clock frequency Data Transfer Mode	$f_{PP}$	S_CLK	$C_{CARD} \leq 10Pf$ (1card)	0	16	MHz
Clock frequency Identification Mode	$f_{OD}$	S_CLK		0*/100	400	kHz
Clock low time	$t_{WL}$	S_CLK		10	-	ns
Clock high time	$t_{WH}$	S_CLK		10	-	ns
Clock rising time	$t_{TLH}$	S_CLK		-	10	ns
Clock falling time	$t_{THL}$	S_CLK		-	10	ns

\*: 0Hz means to stop the clock. The given minimum frequency range is for cases were continues clock is required.

■ Card Inputs CMD, DAT (referenced to Clock CLK)

Parameter	Symbol	Pin name	Conditions	Value		Remarks
				Min	Max	
Input set-up time	$t_{ISU}$	S_CMD, S_DATA3:0	$C_{CARD} \leq 10Pf$ (1card)	5	-	ns
Input hold time	$t_{IH}$	S_CMD, S_DATA3:0		5	-	ns

■ Card Outputs CMD, DAT (referenced to Clock CLK)

Parameter	Symbol	Pin name	Conditions	Value		Remarks
				Min	Max	
Output Delay time during Data Transfer Mode	$t_{ODLY}$	S_CMD, S_DATA3:0	$C_{CARD} \leq 40Pf$ (1card)	0	22	ns
Output Delay time durinn Identification Mode	$t_{ODLY}$	S_CMD, S_DATA3:0		0	50	ns

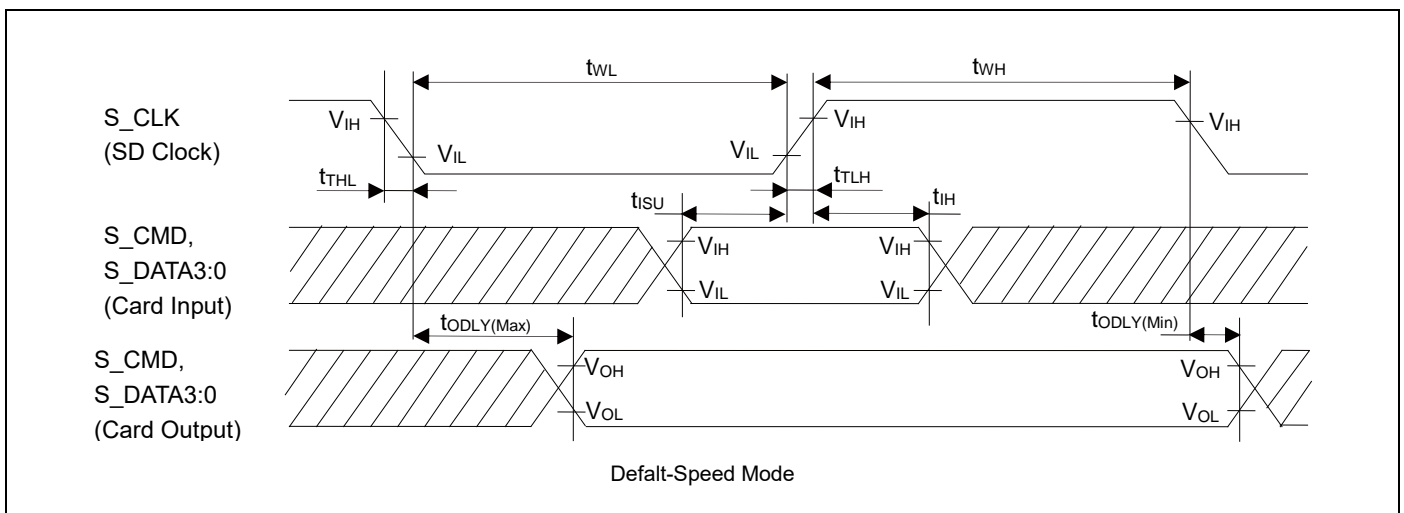

Note:

- The Card Input corresponds to the Host Output and the Card Output corresponds to the Host Input because this model is the Host.

## High-Speed Mode

■ Clock CLK (All values are referred to  $V_{IH}$  and  $V_{IL}$ )

( $V_{CC} = 2.7V$  to  $3.6V$ ,  $V_{SS} = 0V$ )

Parameter	Symbol	Pin name	Conditions	Value		Remarks
				Min	Max	
Clock frequency Data Transfer Mode	$f_{PP}$	S_CLK	$C_{CARD} \leq 10Pf$ (1card)	0	32	MHz
Clock low time	$t_{WL}$	S_CLK		7	-	ns
Clock high time	$t_{WH}$	S_CLK		7	-	ns
Clock rising time	$t_{TLH}$	S_CLK		-	3	ns
Clock falling time	$t_{THL}$	S_CLK		-	3	ns

■ Card Inputs CMD, DAT (referenced to Clock CLK)

Parameter	Symbol	Pin name	Conditions	Value		Remarks
				Min	Max	
Input set-up time	$t_{ISU}$	S_CMD, S_DATA3:0	$C_{CARD} \leq 10Pf$ (1card)	8	-	ns
Input hold time	$t_{IH}$	S_CMD, S_DATA3:0		2	-	ns

■ Card Outputs CMD, DAT (referenced to Clock CLK)

Parameter	Symbol	Pin name	Conditions	Value		Remarks
				Min	Max	
Output Delay time during Data Transfer Mode	$t_{ODLY}$	S_CMD, S_DATA3:0	$C_L \leq 40Pf$ (1card)	-	22	ns
Output Hold time	$t_{OH}$	S_CMD, S_DATA3:0	$C_L \geq 15Pf$ (1card)	2.5	-	ns
Total System capacitance for each line*	$C_L$	-	1card	-	40	Pf

\*: In order to satisfy severe timing, host shall drive only one card.

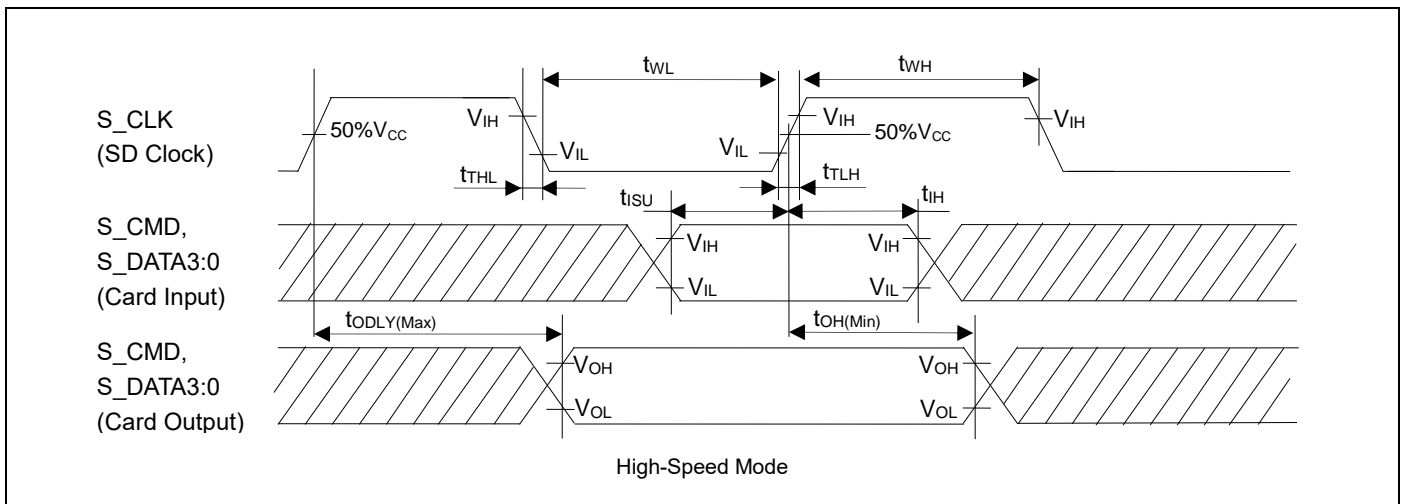

### Notes:

- The Card Input corresponds to the Host Output and the Card Output corresponds to the Host Input because this model is the Host.
- In high-speed mode, set the Clock frequency ( $F_{PP}$ ) and the AHB Bus Clock frequency to the same values.

12.4.16 ETM Timing

(V<sub>CC</sub> = 2.7V to 5.5V, V<sub>SS</sub> = 0V)

Parameter	Symbol	Pin name	Conditions	Value		Unit	Remarks
				Min	Max		
Data hold	t <sub>ETMH</sub>	TRACECLK, TRACED[3:0]	V <sub>CC</sub> ≥ 4.5V	2	9	ns	
			V <sub>CC</sub> < 4.5V	2	15		
TRACECLK frequency	1/ t <sub>TRACE</sub>	TRACECLK	V <sub>CC</sub> ≥ 4.5V	-	50	MHz	
			V <sub>CC</sub> < 4.5V	-	32	MHz	
TRACECLK clock cycle	t <sub>TRACE</sub>	TRACECLK	V <sub>CC</sub> ≥ 4.5V	20	-	ns	
			V <sub>CC</sub> < 4.5V	31.25	-	ns	

**Note:**

- When the external load capacitance C<sub>L</sub> = 30Pf.

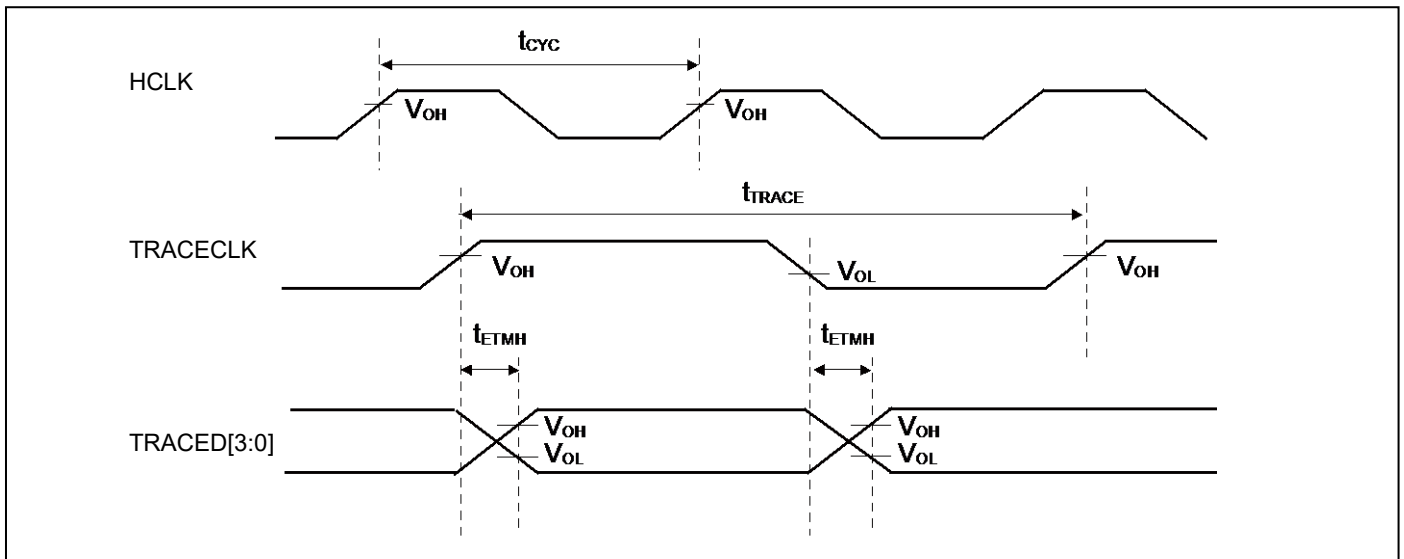

12.4.17 JTAG Timing

( $V_{CC} = 2.7V$  to  $5.5V$ ,  $V_{SS} = 0V$ )

Parameter	Symbol	Pin name	Conditions	Value		Unit	Remarks
				Min	Max		
TMS, TDI setup time	$t_{JTAGS}$	TCK, TMS, TDI	$V_{CC} \geq 4.5V$	15	-	ns	
			$V_{CC} < 4.5V$				
TMS, TDI hold time	$t_{JTAGH}$	TCK, TMS, TDI	$V_{CC} \geq 4.5V$	15	-	ns	
			$V_{CC} < 4.5V$				
TDO delay time	$t_{JTAGD}$	TCK, TDO	$V_{CC} \geq 4.5V$	-	25	ns	
			$V_{CC} < 4.5V$	-	45		

**Note:**

- When the external load capacitance  $C_L = 30Pf$ .

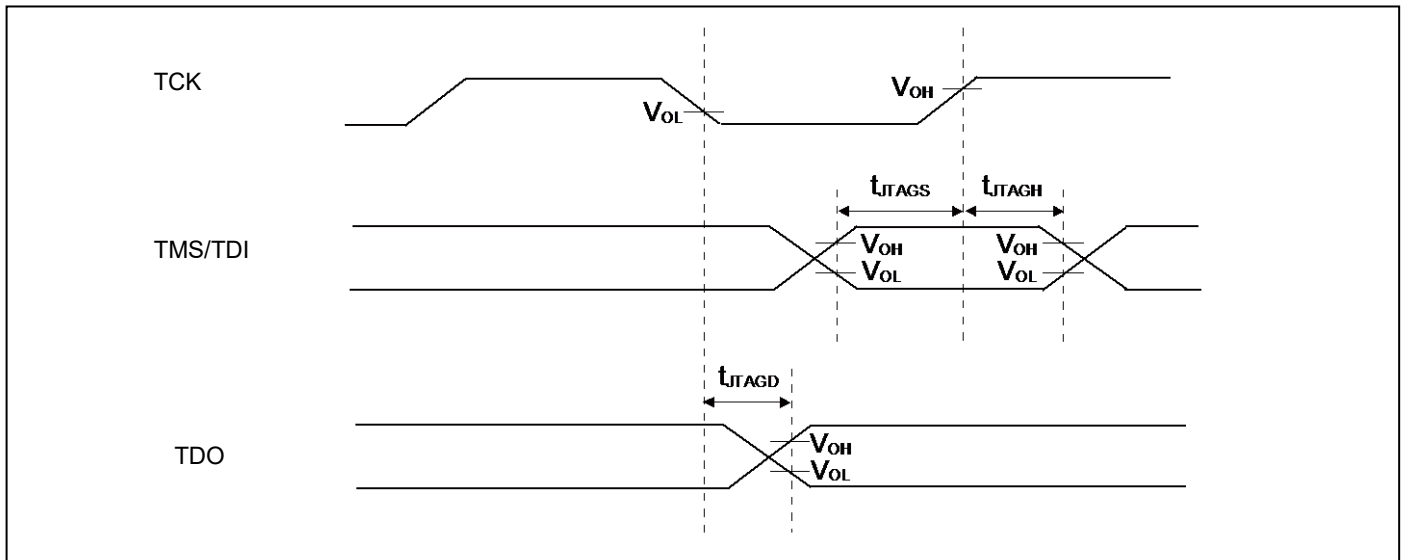

**12.5 12-bit A/D Converter**
**Electrical Characteristics for the A/D Converter**
 $(V_{CC} = AV_{CC} = 2.7V \text{ to } 5.5V, V_{SS} = AV_{SS} = AV_{RL} = 0V)$ 

Parameter	Symbol	Pin name	Value			Unit	Remarks
			Min	Typ	Max		
Resolution	-	-	-	-	12	bit	
Integral Nonlinearity	-	-	- 4.5	-	+ 4.5	LSB	AVRH = 2.7V to 5.5V
Differential Nonlinearity	-	-	-2.5	-	+ 2.5	LSB	
Zero transition voltage	$V_{ZT}$	Anxx	- 15	-	+ 15	Mv	
Full-scale transition voltage	$V_{FST}$	Anxx	AVRH - 15	-	AVRH + 15	Mv	
Conversion time	-	-	0.5*1	-	-	$\mu$ s	$AV_{CC} \geq 4.5V$
Sampling time*2	$T_s$	-	0.15	-	10	$\mu$ s	$AV_{CC} \geq 4.5V$
			0.3	-			$AV_{CC} < 4.5V$
Compare clock cycle*3	$T_{cck}$	-	25	-	1000	ns	$AV_{CC} \geq 4.5V$
			50	-	1000		$AV_{CC} < 4.5V$
State transition time to operation permission	$T_{stt}$	-	-	-	1.0	$\mu$ s	
Power supply current (analog + digital)	-	AVCC	-	0.69	0.92	Ma	A/D 1unit operation
			-	1.0	18	Ma	When A/D stop
Reference power supply current (AVRH)	-	AVRH	-	1.1	1.97	Ma	A/D 1unit operation AVRH = 5.5V
			-	0.3	6.3	Ma	When A/D stop
Analog input capacity	$C_{AIN}$	-	-	-	12.05	Pf	
Analog input resistance	$R_{AIN}$	-	-	-	1.2	K $\omega$	$AV_{CC} \geq 4.5V$
					1.8		$AV_{CC} < 4.5V$
Interchannel disparity	-	-	-	-	4	LSB	
Analog port input leak current	-	Anxx	-	-	5	Ma	
Analog input voltage	-	Anxx	$AV_{SS}$	-	AVRH	V	
Reference voltage	-	AVRH	4.5	-	$AV_{CC}$	V	$T_{cck} < 50ns$
			2.7	-	$AV_{CC}$		$T_{cck} \geq 50ns$

\*1: The conversion time is the value of sampling time ( $T_s$ ) + compare time ( $T_c$ ).

The condition of the minimum conversion time is when the value of sampling time: 150ns, the value of compare time: 350ns ( $AV_{CC} \geq 4.5V$ ). Ensure that it satisfies the value of sampling time ( $T_s$ ) and compare clock cycle ( $T_{cck}$ ). For setting\*4 of sampling time and compare clock cycle, see "Chapter: A/D Converter" in "FM4 Family PERIPHERAL MANUAL Analog Macro Part". The register setting of the A/D Converter is reflected by the peripheral clock timing. The sampling and compare clock are set at Base clock (HCLK).

\*2: A necessary sampling time changes by external impedance. Ensure that it set the sampling time to satisfy (Equation 1).

\*3: The compare time ( $T_c$ ) is the value of (Equation 2).

\*4: The register setting of the A/D Converter is reflected by the timing of the APB bus clock. The sampling clock and compare clock are set in base clock (HCLK). About the APB bus number which the A/D Converter is connected to, see "Block Diagram" in this data sheet.

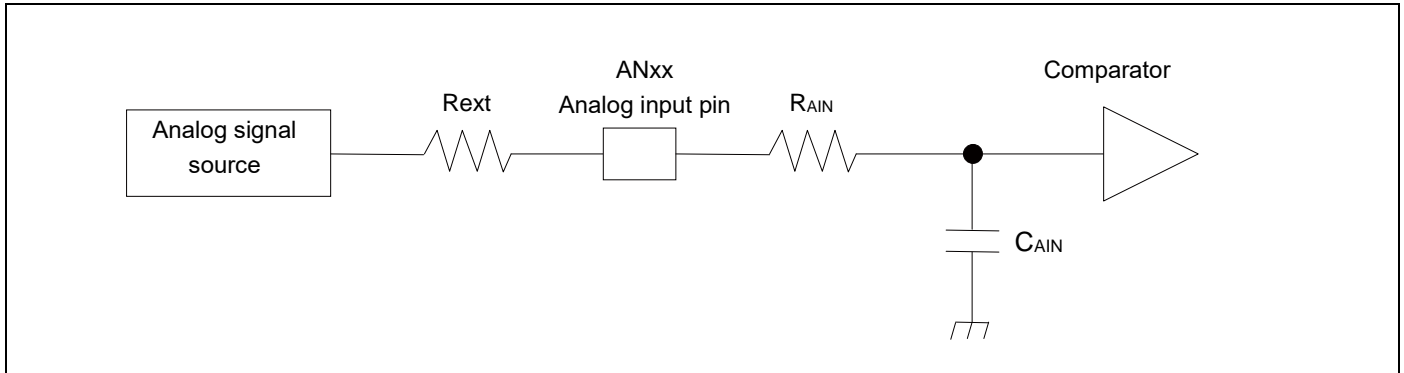

(Equation 1)  $T_s \geq (R_{AIN} + R_{ext}) \times C_{AIN} \times 9$

- T<sub>s</sub>: Sampling time
- R<sub>AIN</sub>: Input resistance of A/D = 1.2K $\omega$  at 4.5V  $\leq$  AV<sub>CC</sub>  $\leq$  5.5V  
Input resistance of A/D = 1.8K $\omega$  at 2.7V  $\leq$  AV<sub>CC</sub>  $\leq$  4.5V
- C<sub>AIN</sub>: Input capacity of A/D = 12.05Pf at 2.7V  $\leq$  AV<sub>CC</sub>  $\leq$  5.5V
- R<sub>ext</sub>: Output impedance of external circuit

(Equation 2)  $T_c = T_{cck} \times 14$

- T<sub>c</sub>: Compare time
- T<sub>cck</sub>: Compare clock cycle

**Definition of 12-bit A/D Converter Terms**

- Resolution: Analog variation that is recognized by an A/D converter.
- Integral Nonlinearity: Deviation of the line between the zero-transition point (0b000000000000 ↔ 0b000000000001) and the full-scale transition point (0b111111111110 ↔ 0b111111111111) from the actual conversion characteristics.
- Differential Nonlinearity: Deviation from the ideal value of the input voltage that is required to change the output code by 1 LSB.

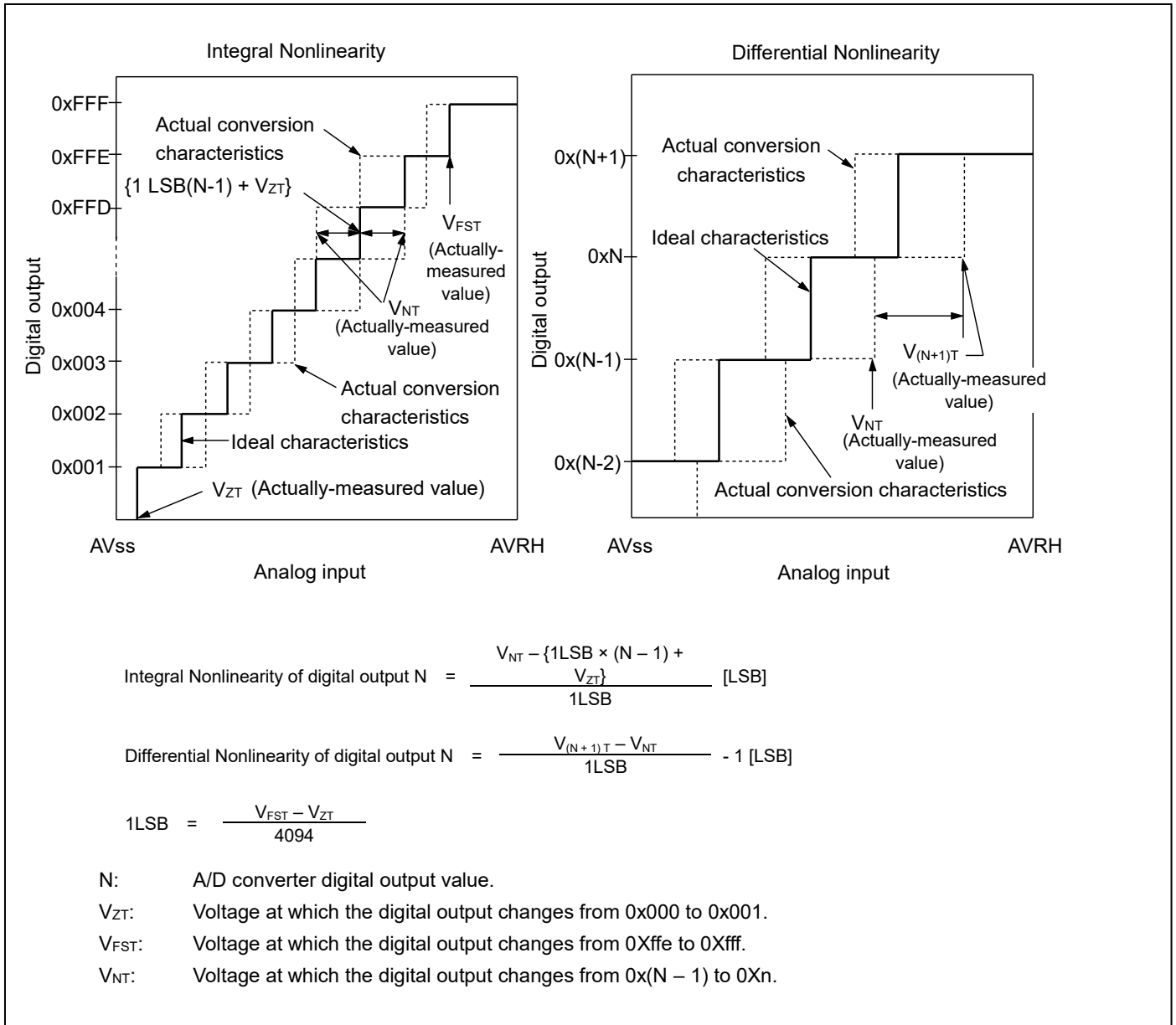

**12.6 12-bit D/A Converter**
**Electrical Characteristics for the D/A Converter**
 $(V_{CC} = AV_{CC} = 2.7V\text{to}5.5V, V_{SS} = AV_{SS} = 0V)$ 

Parameter	Symbol	Pin name	Value			Unit	Remarks
			Min	Typ	Max		
Resolution	-	Dax	-	-	12	bit	
Conversion time	tc20		0.56	0.69	0.81	$\mu$ s	Load 20Pf
	tc100		2.79	3.42	4.06	$\mu$ s	Load 100Pf
Integral Nonlinearity*	INL		- 16	-	+ 16	LSB	
Differential Nonlinearity*	DNL		- 0.98	-	+ 1.5	LSB	
Output voltage offset	$V_{OFF}$		-	-	10.0	Mv	When setting 0x000
			- 20.0	-	+ 1.4	Mv	When setting 0Xfff
Analog output impedance	$R_O$		3.10	3.80	4.50	K $\omega$	D/A operation
		2.0	-	-	M $\Omega$	When D/A stop	
Power supply current*	IDDA	AVCC	260	330	410	Ma	D/A 1unit operation $AV_{CC} = 3.3V$
			400	510	620	Ma	D/A 1unit operation $AV_{CC} = 5.0V$
	IDSA		-	-	14	Ma	When D/A stop

\*: During no load

**12.7 Low-Voltage Detection Characteristics**
**12.7.1 Low-Voltage Detection Reset**

Parameter	Symbol	Conditions	Value			Unit	Remarks
			Min	Typ	Max		
Detected voltage	VDL	-	2.25	2.45	2.65	V	When voltage drops
Released voltage	VDH	-	2.30	2.50	2.70	V	When voltage rises

**12.7.2 Interrupt of Low-Voltage Detection**

Parameter	Symbol	Conditions	Value			Unit	Remarks
			Min	Typ	Max		
Detected voltage	VDL	SVHI = 00111	2.58	2.8	3.02	V	When voltage drops
Released voltage	VDH		2.67	2.9	3.13	V	When voltage rises
Detected voltage	VDL	SVHI = 00100	2.76	3.0	3.24	V	When voltage drops
Released voltage	VDH		2.85	3.1	3.34	V	When voltage rises
Detected voltage	VDL	SVHI = 01100	2.94	3.2	3.45	V	When voltage drops
Released voltage	VDH		3.04	3.3	3.56	V	When voltage rises
Detected voltage	VDL	SVHI = 01111	3.31	3.6	3.88	V	When voltage drops
Released voltage	VDH		3.40	3.7	3.99	V	When voltage rises
Detected voltage	VDL	SVHI = 01110	3.40	3.7	3.99	V	When voltage drops
Released voltage	VDH		3.50	3.8	4.10	V	When voltage rises
Detected voltage	VDL	SVHI = 01001	3.68	4.0	4.32	V	When voltage drops
Released voltage	VDH		3.77	4.1	4.42	V	When voltage rises
Detected voltage	VDL	SVHI = 01000	3.77	4.1	4.42	V	When voltage drops
Released voltage	VDH		3.86	4.2	4.53	V	When voltage rises
Detected voltage	VDL	SVHI = 11000	3.86	4.2	4.53	V	When voltage drops
Released voltage	VDH		3.96	4.3	4.64	V	When voltage rises
LVD stabilization wait time	T <sub>LVDW</sub>	-	-	-	4480×t <sub>CYCP</sub> *	μs	

\*: t<sub>CYCP</sub> indicates the APB2 bus clock cycle time.

**12.8 MainFlash Memory Write/Erase Characteristics**

 (V<sub>CC</sub> = 2.7V to 5.5V)

Parameter		Value			Unit	Remarks
		Min	Typ	Max		
Sector erase time	Large Sector	-	0.7	3.7	s	Includes write time prior to internal erase
	Small Sector		0.3	1.1		
Half word (16-bit) write time	Write cycles ≤ 100 times	-	12	100	μs	Not including system-level overhead time
	Write cycles > 100 times			200		
Chip erase time		-	13.6	68	s	Includes write time prior to internal erase

**Write cycles and data hold time**

Erase/Write cycles (cycle)	Data hold time (year)
1,000	20 *
10,000	10 *
100,000	5 *

\*: This value comes from the technology qualification (using Arrhenius equation to translate high temperature acceleration test result into average temperature value at + 85°C) .

**12.9 WorkFlash Memory Write/Erase Characteristics**

 (V<sub>CC</sub> = 2.7V to 5.5V)

Parameter		Value			Unit	Remarks
		Min	Typ	Max		
Sector erase time		-	0.3	1.5	s	Includes write time prior to internal erase
Half word (16-bit) write time		-	20	200	μs	Not including system-level overhead time
Chip erase time		-	1.2	6	s	Includes write time prior to internal erase

**Write cycles and data hold time**

Erase/Write cycles (cycle)	Data hold time (year)
1,000	20 *
10,000	10 *
100,000	5 *

\*: This value comes from the technology qualification (using Arrhenius equation to translate high temperature acceleration test result into average temperature value at + 85°C) .

12.10 Standby Recovery Time

12.10.1 Recovery cause: Interrupt/WKUP

The time from recovery cause reception of the internal circuit to the program operation start is shown.

Recovery count time

(V<sub>CC</sub> = 2.7V to 5.5V, V<sub>SS</sub> = 0V)

Parameter	Symbol	Value		Unit	Remarks
		Typ	Max*		
Sleep mode	Ticnt	HCLK×1		μs	
High-speed CR Timer mode Main Timer mode PLL Timer mode		40	80	μs	
Low-speed CR timer mode		450	900	μs	
Sub timer mode		896	1136	μs	
RTC mode stop mode (High-speed CR /Main/PLL run mode return)		316	581	μs	
RTC mode stop mode (Low-speed CR/sub run mode return)		270	540		
Deep standby RTC mode with RAM retention Deep standby stop mode with RAM retention		365	667	μs	without RAM retention
		365	667	μs	with RAM retention

\*: The maximum value depends on the built-in CR accuracy.

Example of standby recovery operation (when in external interrupt recovery\*)

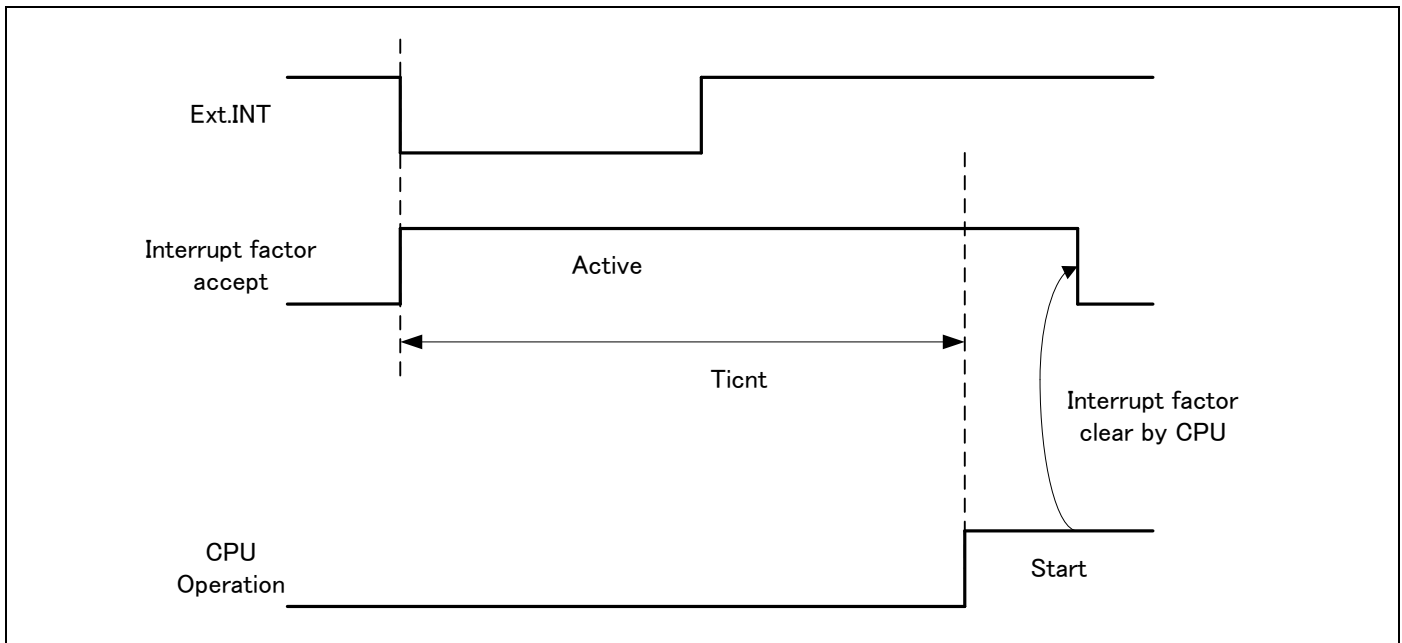

\*: External interrupt is set to detecting fall edge.

Example of standby recovery operation (when in internal resource interrupt recovery\*)

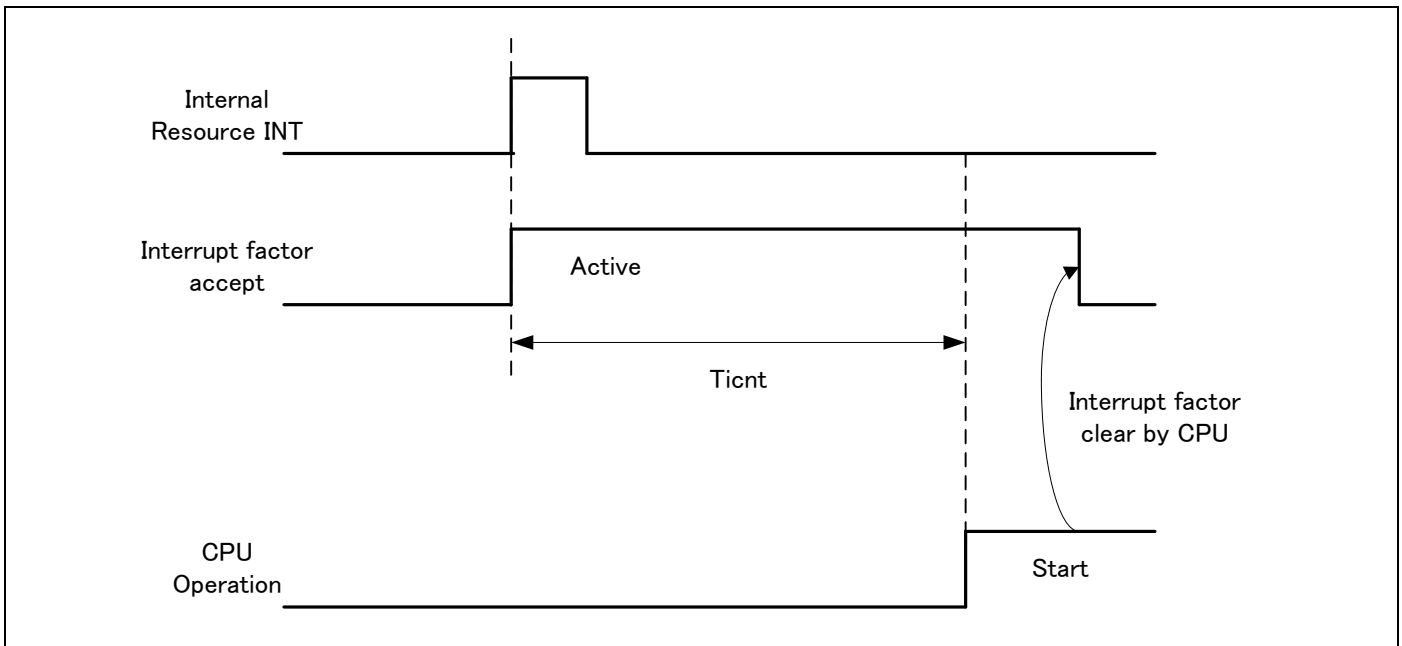

\*: Depending on the standby mode, interrupt from the internal resource is not included in the recovery cause.

**Notes:**

- The return factor is different in each Low-Power consumption modes. See "Chapter: Low Power Consumption Mode" and "Operations of Standby Modes" in FM4 Family Peripheral Manual.
- When interrupt recovers, the operation mode that CPU recovers depends on the state before the Low-Power consumption mode transition. See "Chapter: Low Power Consumption Mode" in "FM4 Family Peripheral Manual".

**12.10.2 Recovery cause: Reset**

The time from reset release to the program operation start is shown.

**Recovery count time**

(V<sub>CC</sub> = 2.7V to 5.5V, V<sub>SS</sub> = 0V)

Parameter	Symbol	Value		Unit	Remarks
		Typ	Max*		
Sleep mode	Trcnt	155	266	μs	
High-speed CR Timer mode Main Timer mode PLL Timer mode		155	266	μs	
Low-speed CR timer mode		315	567	μs	
Sub timer mode		315	567	μs	
RTC mode stop mode		315	567	μs	
Deep standby RTC mode with RAM retention Deep standby stop mode with RAM retention		336	667	μs	without RAM retention
				μs	with RAM retention

\*: The maximum value depends on the built-in CR accuracy.

**Example of standby recovery operation (when in INITX recovery)**

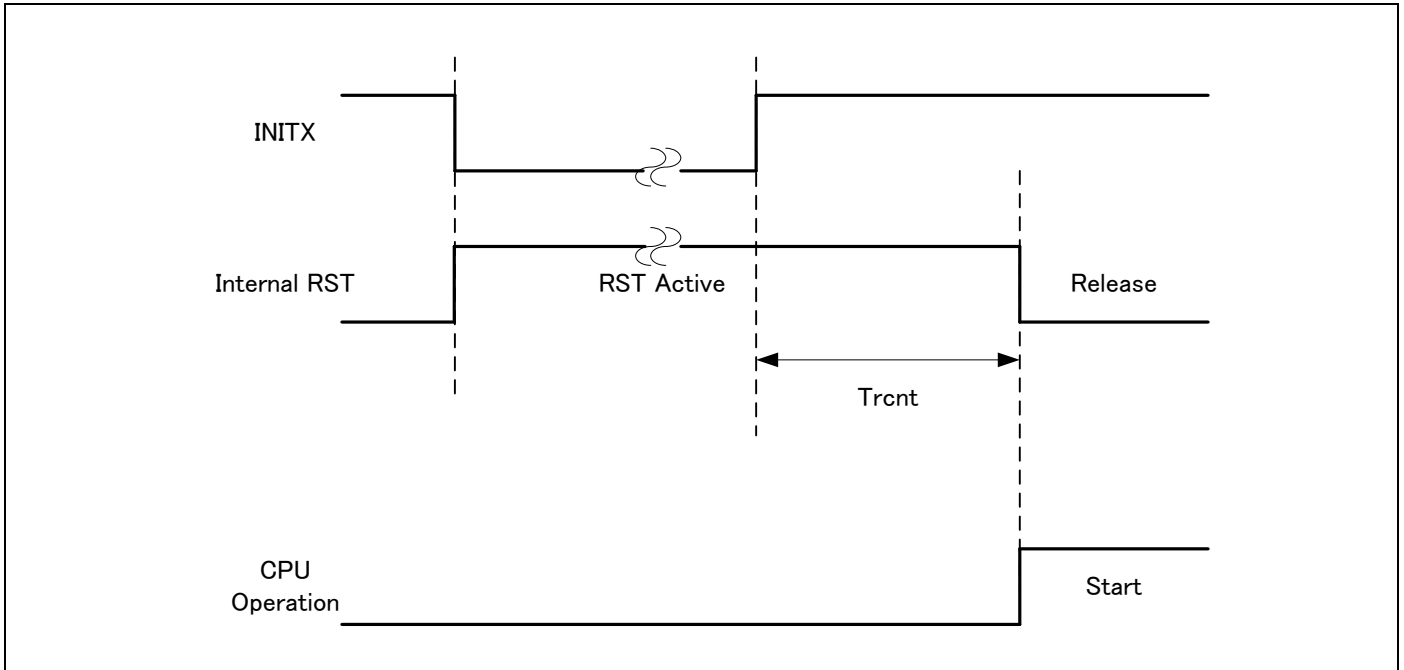

Example of standby recovery operation (when in internal resource reset recovery\*)

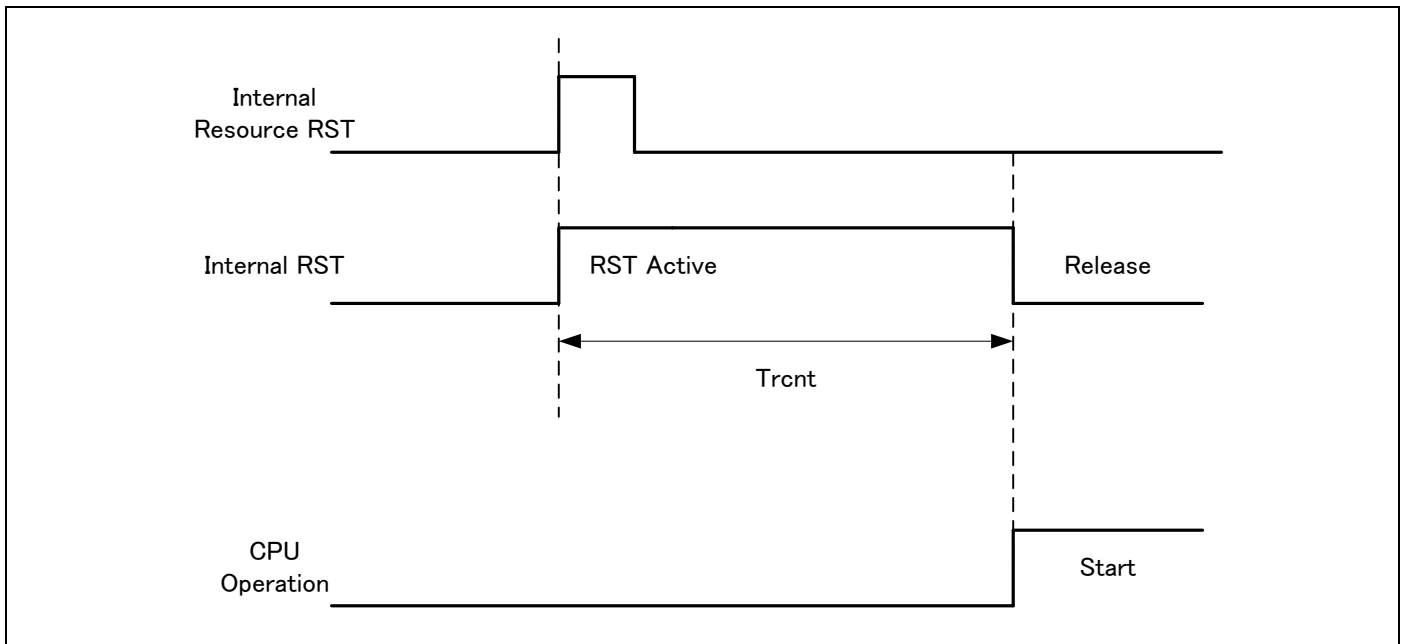

\*: Depending on the standby mode, the reset issue from the internal resource is not included in the recovery cause.

**Notes:**

- The return factor is different in each Low-Power consumption modes. See "Chapter: Low Power Consumption Mode" and "Operations of Standby Modes" in FM4 Family Peripheral Manual.
- The time during the power-on reset/low-voltage detection reset is excluded to the recovery source. See "12.4.7 Power-on Reset Timing" in "12.4. AC Characteristics" in "12.Electrical Characteristics" for the detail on the time during the power-on reset/low-voltage detection reset.
- When in recovery from reset, CPU changes to the high-speed CR run mode. When using the main clock or the PLL clock, it is necessary to add the main clock oscillation stabilization wait time or the main PLL clock stabilization wait time.
- The internal resource reset means the watchdog reset and the CSV reset.

### 13. Ordering Information

Part Number	Flash	RAM	Package
CY9BF168MPMC-GNE2	1 MB	128 KB	Plastic · LQFP (0.5 mm pitch), 80 pin (LQH080)
CY9BF168NPMC-GNE2	1 MB	128 KB	Plastic · LQFP (0.5 mm pitch), 100 pin (LQI100)
CY9BF167NPMC-GNE2	768 KB	96 KB	
CY9BF166NPMC-GNE2	512 KB	64 KB	
CY9BF168RPMC-GNE2	1 MB	128 KB	Plastic · LQFP (0.5 mm pitch), 120 pin (LQM120)
CY9BF167RPMC-GNE2	768 KB	96 KB	
CY9BF166RPMC-GNE2	512 KB	64 KB	

### 14. Package Dimensions

Package Type	Package Code
LQFP-120	LQM120

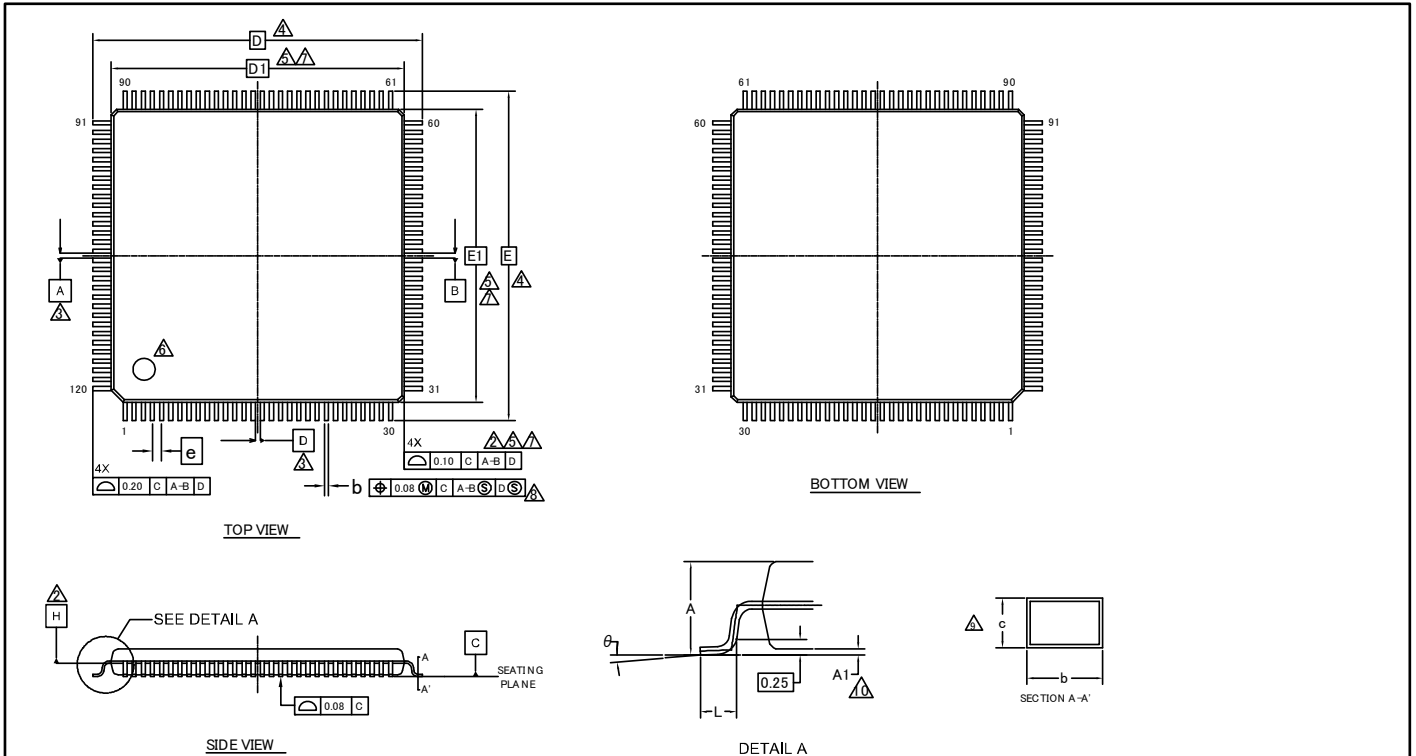

SYMBOL	DIMENSIONS		
	MIN.	NOM.	MAX.
A	—	—	1.70
A1	0.05	—	0.15
b	0.17	0.22	0.27
c	0.115	—	0.195
D	18.00 BSC		
D1	16.00 BSC		
e	0.50 BSC		
E	18.00 BSC		
E1	16.00 BSC		
L	0.45	0.60	0.75
$\theta$	0°	—	8°

**NOTES**

- ALL DIMENSIONS ARE IN MILLIMETERS.
- DATUM PLANE H IS LOCATED AT THE BOTTOM OF THE MOLD PARTING LINE COINCIDENT WITH WHERE THE LEAD EXITS THE BODY.
- DATUMS A-B AND D TO BE DETERMINED AT DATUM PLANE H.
- TO BE DETERMINED AT SEATING PLANE C.
- DIMENSIONS D1 AND E1 DO NOT INCLUDE MOLD PROTRUSION. ALLOWABLE PROTRUSION IS 0.25mm PRE SIDE. DIMENSIONS D1 AND E1 INCLUDE MOLD MISMATCH AND ARE DETERMINED AT DATUM PLANE H.
- DETAILS OF PIN 1 IDENTIFIER ARE OPTIONAL BUT MUST BE LOCATED WITHIN THE ZONE INDICATED.
- REGARDLESS OF THE RELATIVE SIZE OF THE UPPER AND LOWER BODY SECTIONS, DIMENSIONS D1 AND E1 ARE DETERMINED AT THE LARGEST FEATURE OF THE BODY EXCLUSIVE OF MOLD FLASH AND GATE BURRS, BUT INCLUDING ANY MISMATCH BETWEEN THE UPPER AND LOWER SECTIONS OF THE MOLDER BODY.
- DIMENSION b DOES NOT INCLUDE DAMBAR PROTRUSION. THE DAMBAR PROTRUSION (S) SHALL NOT CAUSE THE LEAD WIDTH TO EXCEED b MAXIMUM BY MORE THAN 0.08mm. DAMBAR CANNOT BE LOCATED ON THE LOWER RADIUS OR THE LEAD FOOT.
- THESE DIMENSIONS APPLY TO THE FLAT SECTION OF THE LEAD BETWEEN 0.10mm AND 0.25mm FROM THE LEAD TIP.
- A1 IS DEFINED AS THE DISTANCE FROM THE SEATING PLANE TO THE LOWEST POINT OF THE PACKAGE BODY.

11. JEDEC SPECIFICATION NO. REF: N/A.

PACKAGE OUTLINE 120 LEAD LQFP  
18.0X18.0X1.7 MM LQM120 REV\*\*

002-16172 \*\*

Package Type	Package Code
LQFP-100	LQ100

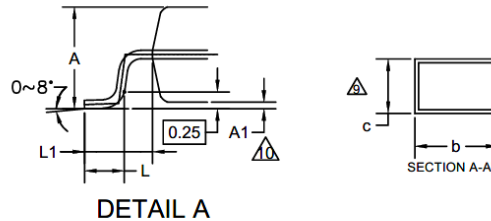
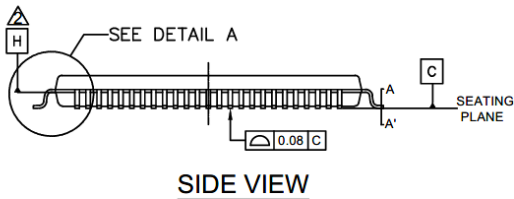
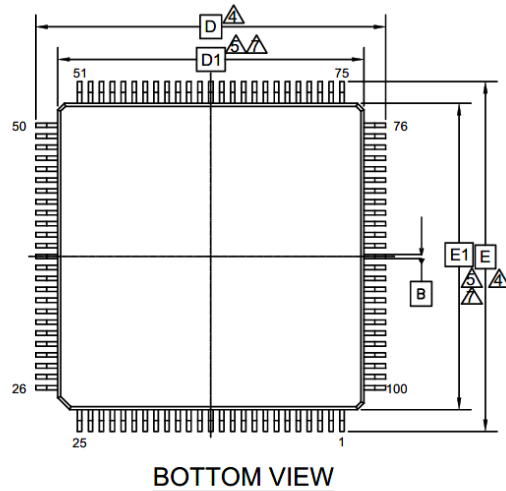
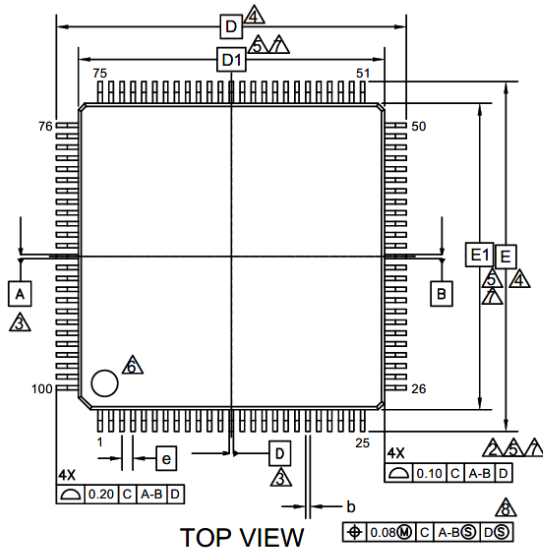

SYMBOL	DIMENSIONS		
	MIN.	NOM.	MAX.
A	—	—	1.70
A1	0.05	—	0.15
b	0.15	—	0.27
c	0.09	—	0.20
D	16.00 BSC		
D1	14.00 BSC		
e	0.50 BSC		
E	16.00 BSC		
E1	14.00 BSC		
L	0.45	0.60	0.75
L1	1.00 REF		

- NOTES :
1. ALL DIMENSIONS ARE IN MILLIMETERS.
  2. DATUM PLANE H IS LOCATED AT THE BOTTOM OF THE MOLD PARTING LINE COINCIDENT WITH WHERE THE LEAD EXITS THE BODY.
  3. DATUMS A-B AND D TO BE DETERMINED AT DATUM PLANE H.
  4. TO BE DETERMINED AT SEATING PLANE C.
  5. DIMENSIONS D1 AND E1 DO NOT INCLUDE MOLD PROTRUSION. ALLOWABLE PROTRUSION IS 0.25mm PRE SIDE. DIMENSIONS D1 AND E1 INCLUDE MOLD MISMATCH AND ARE DETERMINED AT DATUM PLANE H.
  6. DETAILS OF PIN 1 IDENTIFIER ARE OPTIONAL BUT MUST BE LOCATED WITHIN THE ZONE INDICATED.
  7. REGARDLESS OF THE RELATIVE SIZE OF THE UPPER AND LOWER BODY SECTIONS. DIMENSIONS D1 AND E1 ARE DETERMINED AT THE LARGEST FEATURE OF THE BODY EXCLUSIVE OF MOLD FLASH AND GATE BURRS. BUT INCLUDING ANY MISMATCH BETWEEN THE UPPER AND LOWER SECTIONS OF THE MOLDER BODY.
  8. DIMENSION b DOES NOT INCLUDE DAMBAR PROTRUSION. THE DAMBAR PROTRUSION (S) SHALL NOT CAUSE THE LEAD WIDTH TO EXCEED b MAXIMUM BY MORE THAN 0.08mm. DAMBAR CANNOT BE LOCATED ON THE LOWER RADIUS OR THE LEAD FOOT.
  9. THESE DIMENSIONS APPLY TO THE FLAT SECTION OF THE LEAD BETWEEN 0.10mm AND 0.25mm FROM THE LEAD TIP.
  10. A1 IS DEFINED AS THE DISTANCE FROM THE SEATING PLANE TO THE LOWEST POINT OF THE PACKAGE BODY.

002-11500 \*B

Package Type	Package Code
QFP-100	PQH100

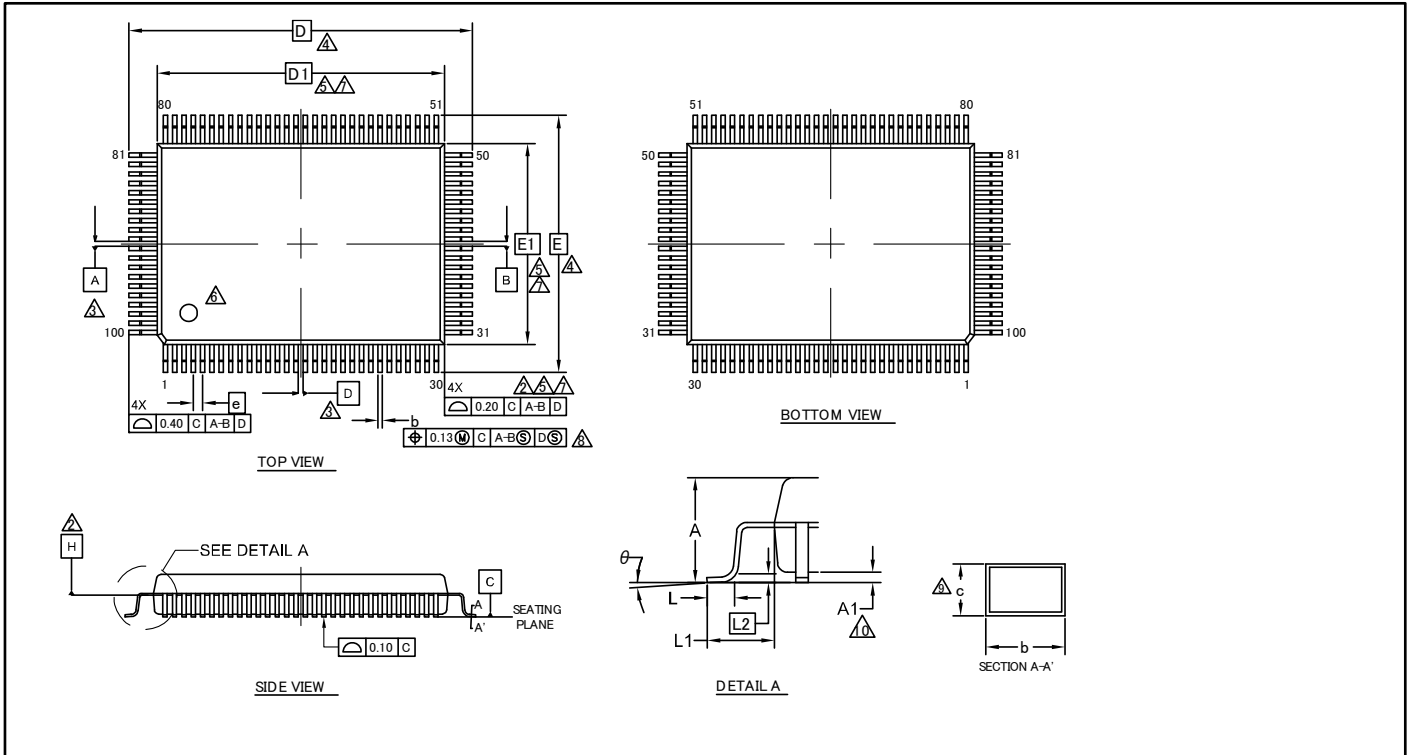

SYMBOL	DIMENSIONS		
	MIN.	NOM.	MAX.
A	—	—	3.35
A1	0.05	—	0.45
b	0.27	0.32	0.37
c	0.11	—	0.23
D	23.90 BSC		
D1	20.00 BSC		
e	0.65 BSC		
E	17.90 BSC		
E1	14.00 BSC		
$\theta$	0°	—	8°
L	0.73	0.88	1.03
L1	1.95 REF		
L2	0.25 BSC		

NOTES

- ALL DIMENSIONS ARE IN MILLIMETERS.
- DATUM PLANE H IS LOCATED AT THE BOTTOM OF THE MOLD PARTING LINE COINCIDENT WITH WHERE THE LEAD EXITS THE BODY.
- DATUMS A-B AND D TO BE DETERMINED AT DATUM PLANE H.
- TO BE DETERMINED AT SEATING PLANE C.
- DIMENSIONS D1 AND E1 DO NOT INCLUDE MOLD PROTRUSION. ALLOWABLE PROTRUSION IS 0.25mm PRE SIDE. DIMENSIONS D1 AND E1 INCLUDE MOLD MISMATCH AND ARE DETERMINED AT DATUM PLANE H.
- DETAILS OF PIN 1 IDENTIFIER ARE OPTIONAL BUT MUST BE LOCATED WITHIN THE ZONE INDICATED.
- REGARDLESS OF THE RELATIVE SIZE OF THE UPPER AND LOWER BODY SECTIONS, DIMENSIONS D1 AND E1 ARE DETERMINED AT THE LARGEST FEATURE OF THE BODY EXCLUSIVE OF MOLD FLASH AND GATE BURRS, BUT INCLUDING ANY MISMATCH BETWEEN THE UPPER AND LOWER SECTIONS OF THE MOLDER BODY.
- DIMENSION b DOES NOT INCLUDE DAMBAR PROTRUSION. THE DAMBAR PROTRUSION (S) SHALL NOT CAUSE THE LEAD WIDTH TO EXCEED b MAXIMUM BY MORE THAN 0.08mm. DAMBAR CANNOT BE LOCATED ON THE LOWER RADIUS OR THE LEAD FOOT.
- THESE DIMENSIONS APPLY TO THE FLAT SECTION OF THE LEAD BETWEEN 0.10mm AND 0.25mm FROM THE LEAD TIP.
- A1 IS DEFINED AS THE DISTANCE FROM THE SEATING PLANE TO THE LOWEST POINT OF THE PACKAGE BODY.

Package Type	Package Code
LQFP-80	LQH080

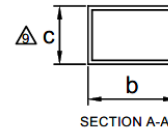
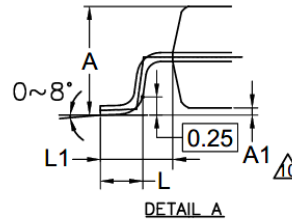
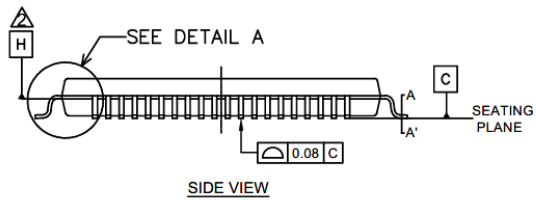
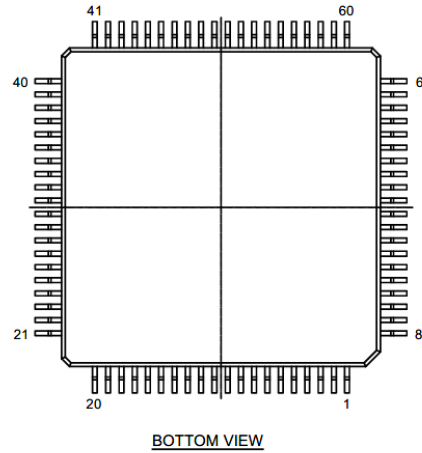
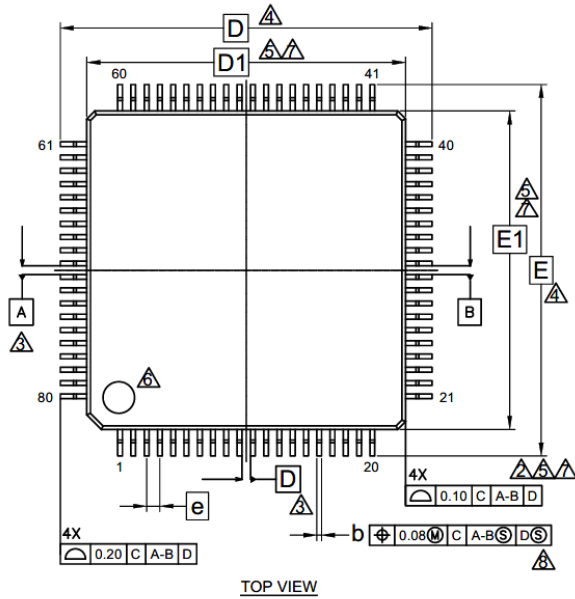

SYMBOL	DIMENSIONS		
	MIN.	NOM.	MAX.
A	—	—	1.70
A1	0.05	—	0.15
b	0.15	—	0.27
c	0.09	—	0.20
D	14.00 BSC.		
D1	12.00 BSC.		
e	0.50 BSC		
E	14.00 BSC.		
E1	12.00 BSC.		
L	0.45	0.60	0.75
L1	1.00 REF		

**NOTES**

- CONTROLLING DIMENSIONS ARE IN MILLIMETERS (mm)
- DATUM PLANE H IS LOCATED AT THE BOTTOM OF THE MOLD PARTING LINE COINCIDENT WITH WHERE THE LEAD EXITS THE BODY.
- DATUMS A-B AND D TO BE DETERMINED AT DATUM PLANE H.
- TO BE DETERMINED AT SEATING PLANE C.
- DIMENSIONS D1 AND E1 DO NOT INCLUDE MOLD PROTRUSION. ALLOWABLE PROTRUSION IS 0.25mm PRE SIDE. DIMENSIONS D1 AND E1 INCLUDE MOLD MISMATCH AND ARE DETERMINED AT DATUM PLANE H.
- DETAILS OF PIN 1 IDENTIFIER ARE OPTIONAL BUT MUST BE LOCATED WITHIN THE ZONE INDICATED.
- REGARDLESS OF THE RELATIVE SIZE OF THE UPPER AND LOWER BODY SECTIONS, DIMENSIONS D1 AND E1 ARE DETERMINED AT THE LARGEST FEATURE OF THE BODY EXCLUSIVE OF MOLD FLASH AND GATE BURRS. BUT INCLUDING ANY MISMATCH BETWEEN THE UPPER AND LOWER SECTIONS OF THE MOLDER BODY.
- DIMENSION b DOES NOT INCLUDE DAMBAR PROTRUSION. THE DAMBAR PROTRUSION(S) SHALL NOT CAUSE THE LEAD WIDTH TO EXCEED b MAXIMUM BY MORE THAN 0.08mm. DAMBAR CANNOT BE LOCATED ON THE LOWER RADIUS OR THE LEAD FOOT.
- THESE DIMENSIONS APPLY TO THE FLAT SECTION OF THE LEAD BETWEEN 0.10mm AND 0.25mm FROM THE LEAD TIP.
- A1 IS DEFINED AS THE DISTANCE FROM THE SEATING PLANE TO THE LOWEST POINT OF THE PACKAGE BODY.

002-11501 \*A

Package Type	Package Code
LQFP-80	LQJ080

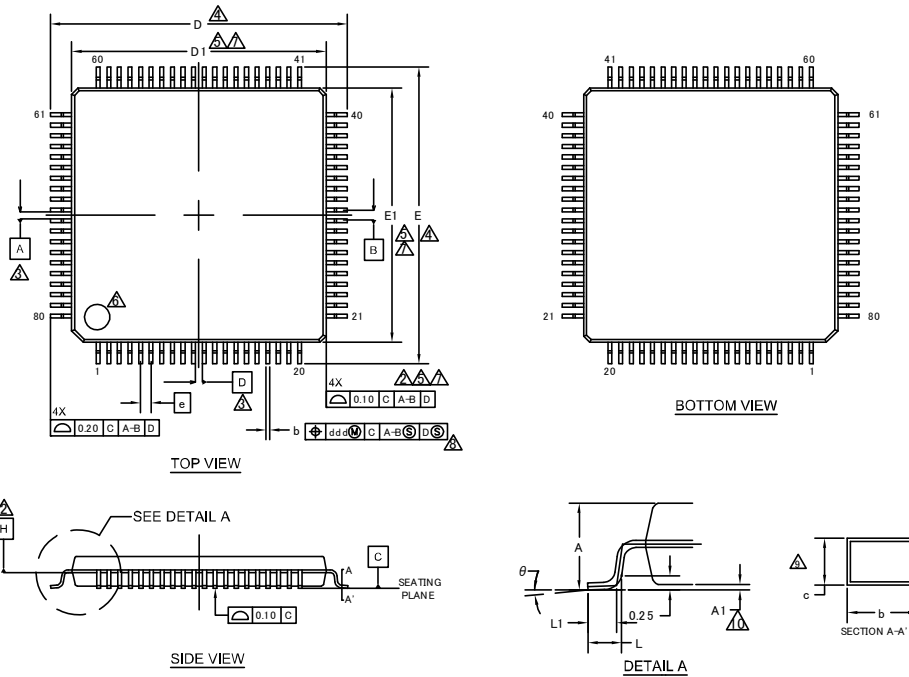

SYMBOL	DIMENSIONS		
	MIN.	NOM.	MAX.
A	—	—	1.70
A1	0.00	—	0.20
b	0.16	0.32	0.38
c	0.09	—	0.20
D	16.00 BSC		
D1	14.00 BSC		
e	0.65 BSC		
E	16.00 BSC		
E1	14.00 BSC		
L	0.45	0.60	0.75
L1	0.30	0.50	0.70
$\theta$	0°	—	8°

**NOTES**

- ALL DIMENSIONS ARE IN MILLIMETERS.
- DATUM PLANE H IS LOCATED AT THE BOTTOM OF THE MOLD PARTING LINE COINCIDENT WITH WHERE THE LEAD EXITS THE BODY.
- DATUMS A-B AND D TO BE DETERMINED AT DATUM PLANE H.
- TO BE DETERMINED AT SEATING PLANE C.
- DIMENSIONS D1 AND E1 DO NOT INCLUDE MOLD PROTRUSION. ALLOWABLE PROTRUSION IS 0.25mm PRE SIDE. DIMENSIONS D1 AND E1 INCLUDE MOLD MISMATCH AND ARE DETERMINED AT DATUM PLANE H.
- DETAILS OF PIN 1 IDENTIFIER ARE OPTIONAL BUT MUST BE LOCATED WITHIN THE ZONE INDICATED.
- REGARDLESS OF THE RELATIVE SIZE OF THE UPPER AND LOWER BODY SECTIONS, DIMENSIONS D1 AND E1 ARE DETERMINED AT THE LARGEST FEATURE OF THE BODY EXCLUSIVE OF MOLD FLASH AND GATE BURRS. BUT INCLUDING ANY MISMATCH BETWEEN THE UPPER AND LOWER SECTIONS OF THE MOLDER BODY.
- DIMENSION b DOES NOT INCLUDE DAMBER PROTRUSION. THE DAMBAR PROTRUSION (S) SHALL NOT CAUSE THE LEAD WIDTH TO EXCEED b MAXIMUM BY MORE THAN 0.08mm. DAMBAR CANNOT BE LOCATED ON THE LOWER RADIUS OR THE LEAD FOOT.
- THESE DIMENSIONS APPLY TO THE FLAT SECTION OF THE LEAD BETWEEN 0.10mm AND 0.25mm FROM THE LEAD TIP.
- A1 IS DEFINED AS THE DISTANCE FROM THE SEATING PLANE TO THE LOWEST POINT OF THE PACKAGE BODY.

PACKAGE OUTLINE, 80 LEAD LQFP  
14.0X14.0X1.7 MM LQJ080 REV\*\*

002-14043 \*\*

Package Type	Package Code
BGA-112	LDC112

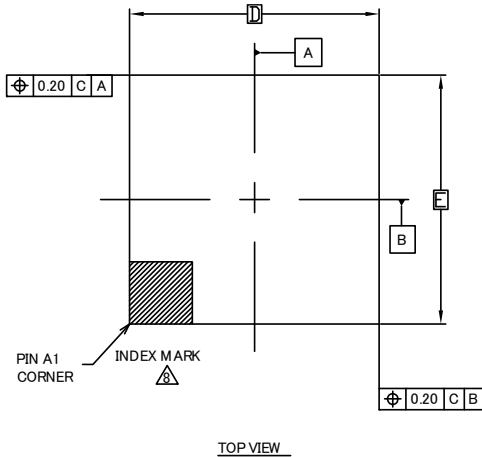

TOP VIEW

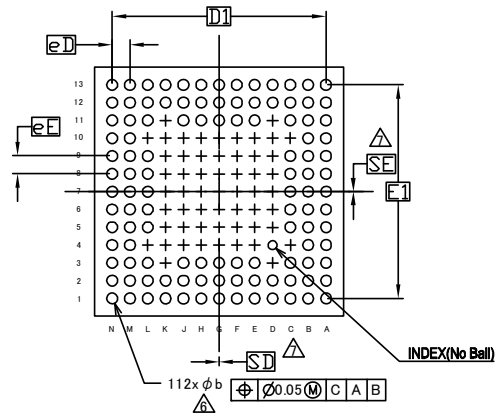

BOTTOM VIEW

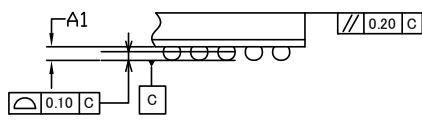

DETAIL A

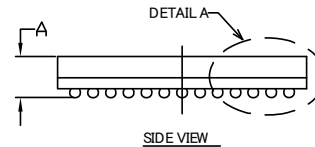

SIDE VIEW

SYMBOL	DIMENSIONS		
	MIN.	NOM.	MAX.
A	—	—	1.35
A1	0.15	0.25	0.35
D	7.00 BSC		
E	7.00 BSC		
D1	6.00 BSC		
E1	6.00 BSC		
MD	13		
ME	13		
n	112		
$\Phi_b$	0.20	0.30	0.40
eD	0.50 BSC		
eE	0.50 BSC		
SD/SE	0.00		

NOTES

- ALL DIMENSIONS ARE IN MILLIMETERS.
- DIMENSIONS AND TOLERANCES METHODS PER ASME Y14.5-2009. THIS OUTLINE CONFORMS TO JEP95, SECTION 4.5.
- BALL POSITION DESIGNATION PER JEP95, SECTION 3, SPP-010.
- "e" REPRESENTS THE SOLDER BALL GRID PITCH.
- SYMBOL "MD" IS THE BALL MATRIX SIZE IN THE "D" DIRECTION. SYMBOL "ME" IS THE BALL MATRIX SIZE IN THE "E" DIRECTION. n IS THE NUMBER OF POPULATED SOLDER BALL POSITIONS FOR MATRIX SIZE MD X ME.
- $\Delta$  DIMENSION "b" IS MEASURED AT THE MAXIMUM BALL DIAMETER IN A PLANE PARALLEL TO DATUM C.
- $\Delta$  "SD" AND "SE" ARE MEASURED WITH RESPECT TO DATUMS A AND B AND DEFINE THE POSITION OF THE CENTER SOLDER BALL IN THE OUTER ROW. WHEN THERE IS AN ODD NUMBER OF SOLDER BALLS IN THE OUTER ROW, "SD" OR "SE" = 0. WHEN THERE IS AN EVEN NUMBER OF SOLDER BALLS IN THE OUTER ROW, "SD" = eD/2 AND "SE" = eE/2.
- $\Delta$  A1 CORNER TO BE IDENTIFIED BY CHAMFER, LASER OR INK MARK. METALLIZED MARK INDENTATION OR OTHER MEANS.
- "+" INDICATES THE THEORETICAL CENTER OF DEPOPULATED BALLS.

PACKAGE OUTLINE, 112 BALL FBGA  
7.0X7.0X1.35 MM LDC112 REV\*\*

002-16663 \*\*

Package Type	Package Code
BGA-144	LDC144

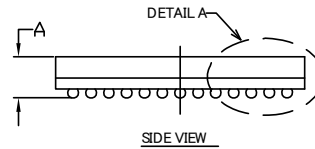
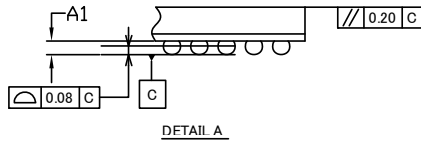
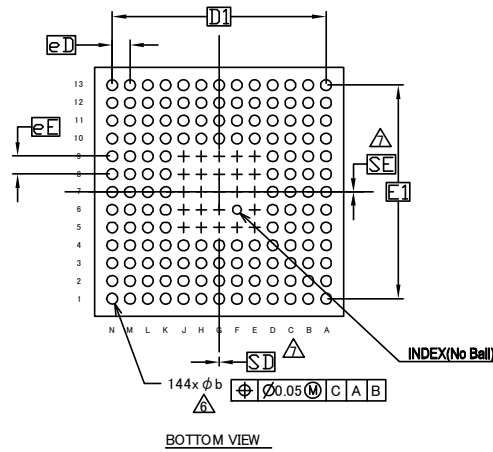
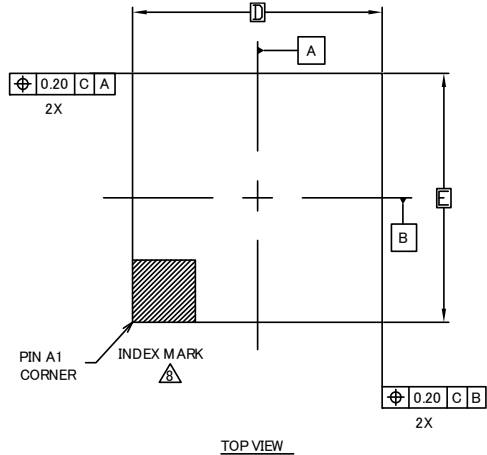

SYMBOL	DIMENSIONS		
	MIN.	NOM.	MAX.
A	—	—	1.30
A1	0.15	0.25	0.35
D	7.00 BSC		
E	7.00 BSC		
D1	6.00 BSC		
E1	6.00 BSC		
MD	13		
ME	13		
n	144		
Φ <sub>b</sub>	0.20	0.30	0.40
eD	0.50 BSC		
eE	0.50 BSC		
SD/SE	0.00		

NOTES

- ALL DIMENSIONS ARE IN MILLIMETERS.
- DIMENSIONS AND TOLERANCES METHODS PER ASME Y14.5-2009. THIS OUTLINE CONFORMS TO JEP95, SECTION 4.5.
- BALL POSITION DESIGNATION PER JEP95, SECTION 3, SPP-010.
- "e" REPRESENTS THE SOLDER BALL GRID PITCH.
- SYMBOL "MD" IS THE BALL MATRIX SIZE IN THE "D" DIRECTION. SYMBOL "ME" IS THE BALL MATRIX SIZE IN THE "E" DIRECTION. n IS THE NUMBER OF POPULATED SOLDER BALL POSITIONS FOR MATRIX SIZE MD X ME.
- DIMENSION "b" IS MEASURED AT THE MAXIMUM BALL DIAMETER IN A PLANE PARALLEL TO DATUM C.
- "SD" AND "SE" ARE MEASURED WITH RESPECT TO DATUMS A AND B AND DEFINE THE POSITION OF THE CENTER SOLDER BALL IN THE OUTER ROW. WHEN THERE IS AN ODD NUMBER OF SOLDER BALLS IN THE OUTER ROW, "SD" OR "SE" = 0. WHEN THERE IS AN EVEN NUMBER OF SOLDER BALLS IN THE OUTER ROW, "SD" = eD/2 AND "SE" = eE/2.
- A1 CORNER TO BE IDENTIFIED BY CHAMFER, LASER OR INK MARK. METALLIZED MARK INDENTATION OR OTHER MEANS.
- "+" INDICATES THE THEORETICAL CENTER OF DEPOPULATED BALLS.

PACKAGE OUTLINE, 144 BALL FBGA  
7.0X7.0X1.3 MM LDC144 REV\*\*

002-16662 \*\*

## 15. Major Changes

Spanion Publication Number: DS709-00004

Page	Section	Change Results
-	-	Preliminary → Data Sheet
1	Description	Deleted the following description: The products which are described in this data sheet are placed into TYPE4 product categories in “FM4 Family PERIPHERAL MANUAL”.
3	Features Multi-Function Serial Interface [I <sup>2</sup> c]	Revised the following description: Fast mode Plus (Fm+) (Max 1000 kbps, only for ch.3 and ch.7) supported →Fast mode Plus (Fm+) (Max 1000 kbps, only for ch.3=ch.A and ch.7=ch.B) supported
7	Features Unique Id	Added new section
9	Product Lineup Function	Added “Unique ID”
51, 52	I/O Circuit Type	Revised the remarks of “Type O, P, Q”
59	Handling Devices Handling When Using Debug Pins	Added new section
60	Block Diagram	Revised the block diagram
72	Electrical Characteristics 2. Recommended Operating Conditions	Revised “Table for package thermal resistance and maximum permissible power”
75 to 80	Electrical Characteristics 3. Dc Characteristics (1) Current Rating	<ul style="list-style-type: none"> <li>Revised the value of TBD</li> <li>Added the note to “ICCVBAT”</li> </ul>
85	Electrical Characteristics 4. Ac Characteristics (2) Sub Clock Input Characteristics	Revised the waveform chart
85	Electrical Characteristics 4. Ac Characteristics (3) Built-In Cr Oscillation characteristics	<ul style="list-style-type: none"> <li>Revised the value of TBD</li> <li>Revised the table and the note of “Built-in High-speed CR”</li> </ul>
144	Electrical Characteristics 5. 12-Bit A/D Converter Electrical Characteristics for the A/D Converter	<ul style="list-style-type: none"> <li>Revised the value of TBD</li> <li>Revised the condition of the electrical characteristics table</li> </ul>
147	Electrical Characteristics 6. 12-Bit D/A Converter Electrical Characteristics for the D/A Converter	<ul style="list-style-type: none"> <li>Revised the value of TBD</li> <li>Revised the condition and Remarks of the electrical characteristics table</li> </ul>
150	Electrical Characteristics 10. Standby Recovery Time (1) Recovery Cause : Interrupt/Wkup	<ul style="list-style-type: none"> <li>Revised the value of TBD</li> <li>Revised the table of Recovery count time</li> </ul>
152	Electrical Characteristics 10. Standby Recovery Time (2) Recovery Cause : Reset	<ul style="list-style-type: none"> <li>Revised the value of TBD</li> <li>Revised the table of Recovery count time</li> </ul>

Note: Please see “Document History” about later revised information.

## Document History

Document Title: CY9B160R Series, 32-bit ARM® Cortex®-M4F FM4 Microcontroller

Document Number: 002-04918

Revision	MB9B160R Series ECN	Orig. of Change	Submission Date	Description of Change
**	–	AKIH	06/27/2013	Migrated to Cypress and assigned document number 002-04918. No change to document contents or format.
*A	5162380	AKIH	03/07/2016	Updated to Cypress template.
*B	5516291	YSKA	02/02/2017	<p>Updated “12.4.7 Power-On Reset Timing”. Changed parameter from “Power Supply rise time(Tr)[ms]” to “Power ramp rate(Dv/dt)[Mv/us]” and add some comments (<a href="#">Page 84</a>)</p> <p>Modified the Chapter name “12.4.11 UART Timing” to “12.4.11 CSIO/UART Timing”. (<a href="#">Page 97</a>)</p> <p>Modified “12.4.11 CSIO/UART Timing”. Deleted “SPI=1, MS=0” in the titles and added MS=0,1 in the schematic (<a href="#">Page 105-112, 121-128</a>)</p> <p>Added the Baud rate spec in “12.4.12 CSIO/UART Timing”.(<a href="#">Page 97, 99, 101, 103</a>)</p> <p>“Modified RTC description in “Features, Real-Time Clock(RTC)” Changed starting count value from 01 to 00. Deleted “second, or day of the week” in the Interrupt function (<a href="#">Page 3</a>)</p> <p>Added Maximum Access size in “Features” (<a href="#">Page 1</a>)</p> <p>Modifications related to the VBAT in the following chapter.</p> <p>“7. Handling Devices” Notes on Power-on (<a href="#">Page 54</a>) “11. Pin Status in Each CPU State” List of VBAT Domain Pin Status (<a href="#">Page 66</a>) “12.3.1 Current Rating” Table 12-9. Typical and Maximum Current Consumption in Deep Standby STOP Mode, Deep Standby RTC Mode and VBAT (<a href="#">Page 77</a>)</p> <p>Added Notes for JTAG (<a href="#">Page 42</a>), Changed “J-TAG” to” JTAG” in “4 List of Pin Functions” (<a href="#">Page 30</a>)</p> <p>Modify typo in number of power supply (Three -&gt; Two) (<a href="#">Page 4</a>)</p> <p>Updated Package code and dimensions as follows (<a href="#">Page 8-14, 68, 150-156</a>)</p> <p>FPT-120P-M37 -&gt; LQM120, FPT-100P-M23 -&gt; LQI100,  FPT-100P-M36 -&gt; PQH100, FPT-80P-M37 -&gt; LQH080,  FPT-80P-M40 -&gt; LQJ080, BGA-112P-M05 -&gt; LDC112,  BGA-144P-M09 -&gt; LDC144</p> <p>Changed the mode name of I2C as follows (<a href="#">Page 2, 133-134</a>)</p> <p>Typical mode -&gt; Standard-mode, High-speed mode -&gt; Fast-mode</p> <p>Modified from “Analog port input current” to “Analog port input leak current” in “12.5 12-bit A/D Converter” (<a href="#">Page 139</a>)</p> <p>Modified according to the Datasheet Errata as below (No.1-9)</p> <ol style="list-style-type: none"> <li>1. Modified Reference voltage value in “Electrical Characteristics for the A/D Converter” in “12.5 12-bit A/D Converter” (<a href="#">Page 139</a>)</li> <li>2. Modified typo in “Features, Processor version” (<a href="#">Page 1</a>)</li> <li>3. Updated Remarks of Type H, I in “5. I/O Circuit Type” (<a href="#">Page 45</a>)</li> </ol>

Revision	MB9B160R Series ECN	Orig. of Change	Submission Date	Description of Change
				4. Updated "List of VBAT Domain Pin Status" ( <a href="#">Page 66</a> ) 5. Modified "12.2 Recommended Operating Conditions" ( <a href="#">Page 68</a> ) 6. Added "Frequency stabilization time" spec in "12.4.3 Built-in CR Oscillation Characteristics" ( <a href="#">Page 82</a> ) 7. Added "Conversion time" spec in "12.6 12-bit D/A Converter" ( <a href="#">Page 142</a> ) 8. Modified some spec values in "12.10.1 Recovery cause: Interrupt/WKUP" ( <a href="#">Page 145</a> ) and "12.10.2 Recovery cause: Reset" ( <a href="#">Page 147</a> ) 9. Modified the "sampling time" and "State transition time to operation permission" spec values in "12.5 12-bit A/D Converter" ( <a href="#">Page 139</a> ) Deleted MPNs below from "13. Ordering Information" ( <a href="#">Page 149</a> ) MB9BF166RBGL-GE1, MB9BF167RBGL-GE1, MB9BF168RBGL-GE1 Added MPNs below to "13. Ordering Information" ( <a href="#">Page 149</a> ) MB9BF166RBGL-GK7E1, MB9BF167RBGL-GK7E1, MB9BF168RBGL-GK7E1 Updated IO circuit (type A, N, O) ( <a href="#">Page 43</a> ) Modified the expression of the "Reference power supply current" "12.5 12-bit A/D Converter" ( <a href="#">Page 139</a> ) Modified the expression of the "Built-in CR" and add Note in the "1. Product Lineup" ( <a href="#">Page 7</a> ) Modified typo (SCLKx_0 -> SCKx_0) ( <a href="#">Page 97, 99, 101, 103</a> )
*C	5738077	YSAT	05/16/2017	Updated Cypress Logo and Copyright.
*D	5873294	HUAL	09/25/2017	1.new note format had been updated from *x to ** 2.double heading number had been cancelled on chapter 12.2 3.some chapter number missed in reference Updated Electrical Characteristics: Updated Recommended Operating Conditions: Updated description.
*E	6623270	XITO	07/15/2019	Updated Ordering Information: Updated part numbers. Updated to new template.
*F	6886941	XITO	06/18/2020	Updated Document Title to read as "CY9B160R Series, 32-bit ARM® Cortex®-M4F FM4 Microcontroller". Replaced MB9B160R with CY9B160R in all instances across the document. Updated Ordering Information: Updated part numbers.
*G	7218160	XITO	08/21/2021	Updated Ordering Information: Updated part numbers. Updated Package Dimensions: spec 002-11500 – Changed revision from *A to *B. spec 002-11501 – Changed revision from ** to *A.

## Sales, Solutions, and Legal Information

### Worldwide Sales and Design Support

Cypress maintains a worldwide network of offices, solution centers, manufacturer's representatives, and distributors. To find the office closest to you, visit us at [Cypress Locations](#).

### Products

ARM® Cortex® Microcontrollers	<a href="http://cypress.com/arm">cypress.com/arm</a>
Automotive	<a href="http://cypress.com/automotive">cypress.com/automotive</a>
Clocks & Buffers	<a href="http://cypress.com/clocks">cypress.com/clocks</a>
Interface	<a href="http://cypress.com/interface">cypress.com/interface</a>
Internet of Things	<a href="http://cypress.com/iot">cypress.com/iot</a>
Memory	<a href="http://cypress.com/memory">cypress.com/memory</a>
Microcontrollers	<a href="http://cypress.com/mcu">cypress.com/mcu</a>
PSoC	<a href="http://cypress.com/psoc">cypress.com/psoc</a>
Power Management ICs	<a href="http://cypress.com/pmic">cypress.com/pmic</a>
Touch Sensing	<a href="http://cypress.com/touch">cypress.com/touch</a>
USB Controllers	<a href="http://cypress.com/usb">cypress.com/usb</a>
Wireless/RF	<a href="http://cypress.com/wireless">cypress.com/wireless</a>

### PSoC® Solutions

[PSoC 1](#) | [PSoC 3](#) | [PSoC 4](#) | [PSoC 5LP](#) | [PSoC 6 MCU](#)

### Cypress Developer Community

[Forums](#) | [WICED IOT Forums](#) | [Projects](#) | [Video](#) | [Blogs](#) | [Training](#) | [Components](#)

### Technical Support

[cypress.com/support](http://cypress.com/support)

ARM and Cortex are the registered trademarks of ARM Limited in the EU and other countries.



© Cypress Semiconductor Corporation, 2013-2021. This document is the property of Cypress Semiconductor Corporation and its subsidiaries ("Cypress"). This document, including any software or firmware included or referenced in this document ("Software"), is owned by Cypress under the intellectual property laws and treaties of the United States and other countries worldwide. Cypress reserves all rights under such laws and treaties and does not, except as specifically stated in this paragraph, grant any license under its patents, copyrights, trademarks, or other intellectual property rights. If the Software is not accompanied by a license agreement and you do not otherwise have a written agreement with Cypress governing the use of the Software, then Cypress hereby grants you a personal, non-exclusive, nontransferable license (without the right to sublicense) (1) under its copyright rights in the Software (a) for Software provided in source code form, to modify and reproduce the Software solely for use with Cypress hardware products, only internally within your organization, and (b) to distribute the Software in binary code form externally to end users (either directly or indirectly through resellers and distributors), solely for use on Cypress hardware product units, and (2) under those claims of Cypress's patents that are infringed by the Software (as provided by Cypress, unmodified) to make, use, distribute, and import the Software solely for use with Cypress hardware products. Any other use, reproduction, modification, translation, or compilation of the Software is prohibited.

TO THE EXTENT PERMITTED BY APPLICABLE LAW, CYPRESS MAKES NO WARRANTY OF ANY KIND, EXPRESS OR IMPLIED, WITH REGARD TO THIS DOCUMENT OR ANY SOFTWARE OR ACCOMPANYING HARDWARE, INCLUDING, BUT NOT LIMITED TO, THE IMPLIED WARRANTIES OF MERCHANTABILITY AND FITNESS FOR A PARTICULAR PURPOSE. No computing device can be absolutely secure. Therefore, despite security measures implemented in Cypress hardware or software products, Cypress shall have no liability arising out of any security breach, such as unauthorized access to or use of a Cypress product. CYPRESS DOES NOT REPRESENT, WARRANT, OR GUARANTEE THAT CYPRESS PRODUCTS, OR SYSTEMS CREATED USING CYPRESS PRODUCTS, WILL BE FREE FROM CORRUPTION, ATTACK, VIRUSES, INTERFERENCE, HACKING, DATA LOSS OR THEFT, OR OTHER SECURITY INTRUSION (collectively, "Security Breach"). Cypress disclaims any liability relating to any Security Breach, and you shall and hereby do release Cypress from any claim, damage, or other liability arising from any Security Breach. In addition, the products described in these materials may contain design defects or errors known as errata which may cause the product to deviate from published specifications. To the extent permitted by applicable law, Cypress reserves the right to make changes to this document without further notice. Cypress does not assume any liability arising out of the application or use of any product or circuit described in this document. Any information provided in this document, including any sample design information or programming code, is provided only for reference purposes. It is the responsibility of the user of this document to properly design, program, and test the functionality and safety of any application made of this information and any resulting product. "High-Risk Device" means any device or system whose failure could cause personal injury, death, or property damage. Examples of High-Risk Devices are weapons, nuclear installations, surgical implants, and other medical devices. "Critical Component" means any component of a High-Risk Device whose failure to perform can be reasonably expected to cause, directly or indirectly, the failure of the High-Risk Device, or to affect its safety or effectiveness. Cypress is not liable, in whole or in part, and you shall and hereby do release Cypress from any claim, damage, or other liability arising from any use of a Cypress product as a Critical Component in a High-Risk Device. You shall indemnify and hold Cypress, its directors, officers, employees, agents, affiliates, distributors, and assigns harmless from and against all claims, costs, damages, and expenses, arising out of any claim, including claims for product liability, personal injury or death, or property damage arising from any use of a Cypress product as a Critical Component in a High-Risk Device. Cypress products are not intended or authorized for use as a Critical Component in any High-Risk Device except to the limited extent that (i) Cypress's published data sheet for the product explicitly states Cypress has qualified the product for use in a specific High-Risk Device, or (ii) Cypress has given you advance written authorization to use the product as a Critical Component in the specific High-Risk Device and you have signed a separate indemnification agreement.



Cypress, the Cypress logo, Spansion, the Spansion logo, and combinations thereof, WICED, PSoC, CapSense, EZ-USB, F-RAM, and Traveo are trademarks or registered trademarks of Cypress in the United States and other countries. For a more complete list of Cypress trademarks, visit [cypress.com](http://cypress.com). Other names and brands may be claimed as property of their respective owners.

## Looking for pricing, stock, or lifecycle information?

Click below to explore more details on WIN SOURCE:

-  [View MB9BF168RPMC-G-JNE2 on WIN SOURCE](#)
-  [Cypress Semiconductor Corp Information](#)

## Optimize Your Supply Chain with WIN SOURCE Solutions

-  Global Sourcing Solution
-  Obsolete Management
-  Cost Control Management
-  Shortage Management
-  Alternative Solution
-  Excess Inventory Management