



**THE DATASHEET OF
MC56F8255MLD**





16-bit Digital Signal Controllers

MC56F82xx

For power conversion and motor control

Target Applications

- Switched-mode power supplies and power management
- Motor control (ACIM, BLDC, PMSM, SR and stepper)
- Battery chargers and management
- Solar inverters
- Industrial control
- Home appliances
- Smart sensors
- Fire and security systems
- Power metering
- Hand-held power tools
- Arc detection
- Medical devices/equipment
- Lighting ballast

Overview

The MC56F825x/MC56F824x is a member of the 56800E core-based family of digital signal controllers (DSCs). It combines, on a single chip, the processing power of a DSP and the functionality of a microcontroller with fast and powerful peripherals to create a cost-effective solution. Because of its low cost, configuration

MC56F82xx

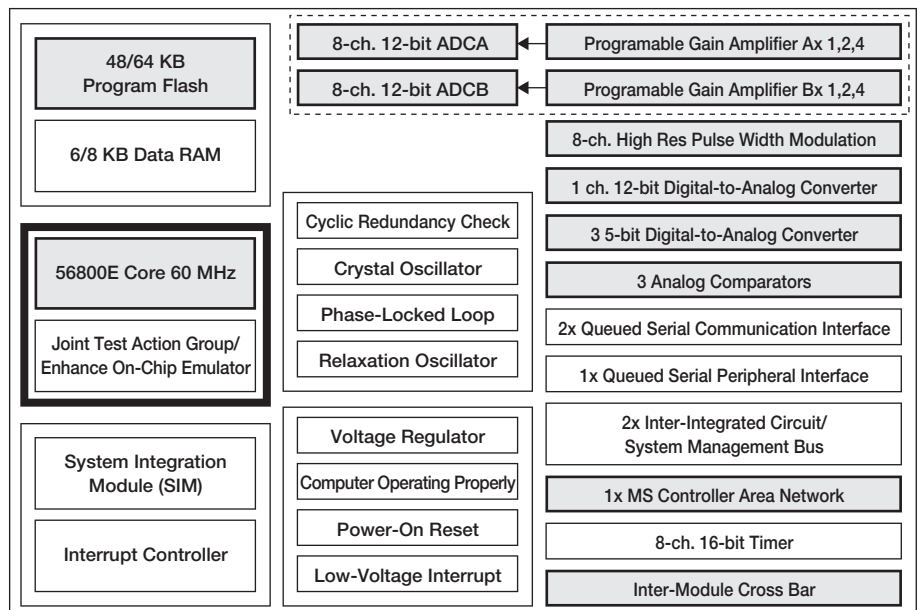

flexibility and compact program code, the MC56F825x/MC56F824x is well-suited for many consumer and industrial applications especially advanced power conversion and motor control.

Development Tools

TWR-56F8257

Cost-effective development board that is part of the Freescale Tower System, a modular development platform that enables rapid prototyping and re-use through reconfigurable hardware.

CodeWarrior for DSC v8.3

CodeWarrior Development Studio is a complete integrated development environment (IDE) that provides a highly-visual and automated framework to accelerate the development of the most complex embedded applications.

FreeMASTER Run-Time Debugging Tool

FreeMASTER software (formerly known as PC Master) represents a sophisticated tool with intuitive navigation that can be used in any application development. This tool allows control of an application remotely from a user-friendly graphical environment running on a PC. It also provides the ability to view real-time application variables in both textual and graphical form.

Features and Benefits

Features	Benefits
Fast, Powerful Peripherals	
eFlexPWM channels	Reduce signal ripple to precisely modulate energy Achieve precise switching frequency generation
PGA-enabled ultra-fast ADCs	Precisely measure power supply and motor control currents
Increased Processing Power	
Dual Harvard-style architecture	Allows as many as six operations per instruction cycle
Hybrid DSP and MCU functionality	Allows for generation of efficient, compact DSP and control code
Inter-module crossbar switch (XBAR)	Allows programmable internal module connections between and among eFlexPWM, ADC, QuadTimers, DACs, HSCMPs and package pins
Reduced System Cost	
Embedded 12-bit DAC	Provides a reference to on-chip comparators or generates a waveform to a package pin, generating square, triangle and sawtooth waveforms, eliminating the need for external components
EEPROM emulation capability	Provides up to 64KB of embedded, secured and protected flash memory

Package Options

Part Number	Temp Ranges	Package
PC56F8245VLD	-40°C to +105°C	44 LQFP
PC56F8246VLF	-40°C to +105°C	48 LQFP
PC56F8247VLH	-40°C to +105°C	64 LQFP
PC56F8255VLD	-40°C to +105°C	44 LQFP
PC56F8256VLF	-40°C to +105°C	48 LQFP
PC56F8257VLH	-40°C to +105°C	64 LQFP

Learn More: For more information, visit freescale.com/MC56F82xx, freescale.com/dsc and freescale.com/tower

Looking for pricing, stock, or lifecycle information?

Click below to explore more details on WIN SOURCE:

 [View MC56F8255MLD on WIN SOURCE](#)

 [NXP / Nexperia Information](#)

Optimize Your Supply Chain with WIN SOURCE Solutions

-  Global Sourcing Solution
-  Obsolete Management
-  Cost Control Management
-  Shortage Management
-  Alternative Solution
-  Excess Inventory Management