



**THE DATASHEET OF
NB3N111KMNR4G**



3.3 V Differential 1:10 Fanout Clock Driver with HCSL Outputs

NB3N111K

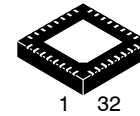

QFN32
MN SUFFIX
CASE 488AM

Description

The NB3N111K is a differential 1:10 Clock fanout buffer with High-speed Current Steering Logic (HCSL) outputs optimized for ultra low propagation delay variation. The NB3N111K is designed with PCI Express HCSL clock distribution and FBDIMM applications in mind.

Inputs can directly accept differential LVPECL, LVDS, and HCSL signals per Figures 7, 8, and 9. Single-ended LVPECL, HCSL, LVCMOS, or LVTTTL levels are accepted with a proper external V_{th} reference supply per Figures 4 and 10. Input pins incorporate separate internal 50 Ω termination resistors allowing additional single ended system interconnect flexibility.

Output drive current is set by connecting a 475 Ω resistor from IREF (Pin 1) to GND per Figure 6. Outputs can also interface to LVDS receivers when terminated per Figure 11.

The NB3N111K specifically guarantees low output-to-output skew. Optimal design, layout, and processing minimize skew within a device and from device to device. System designers can take advantage of the NB3N111K's performance to distribute low skew clocks across the backplane or the motherboard.

Features

- Typical Input Clock Frequency 100, 133, 166, or 400 MHz
- 220 ps Typical Rise and Fall Times
- 800 ps Typical Propagation Delay
- Δt_{pd} 100 ps Maximum Propagation Delay Variation per Diff Pair
- 0.1 ps Typical RMS Additive Phase Jitter
- LVDS Output Levels Optional with Interface Termination
- Operating Range: $V_{CC} = 3.0\text{ V to }3.6\text{ V}$ with $GND = 0\text{ V}$
- Typical HCSL Output Levels (700 mV Peak-to-Peak)
- LVDS Output Levels with Interface Termination
- These are Pb-Free Devices

Applications

- Clock Distribution
- PCIe I, II, III
- Networking
- High End Computing
- Routers

End Products

- Servers
- FBDIMM Memory Card

MARKING DIAGRAM*

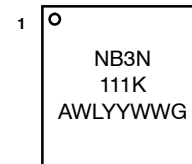

- A = Assembly Location
- WL = Wafer Lot
- YY = Year
- WW = Work Week
- G = Pb-Free Package

*For additional marking information, refer to Application Note [AND8002/D](#).

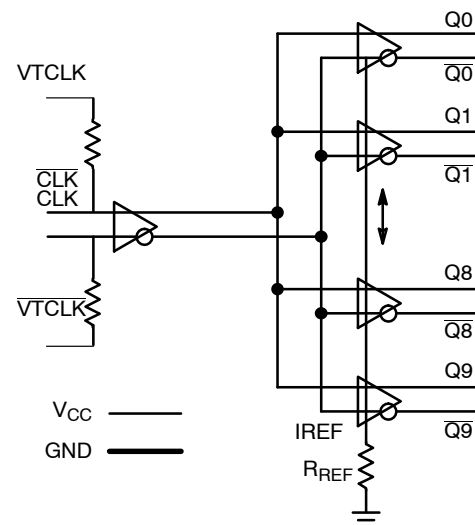

Figure 1. Simplified Logic Diagram

ORDERING INFORMATION

See detailed ordering and shipping information in the package dimensions section on page 8 of this data sheet.

NB3N111K

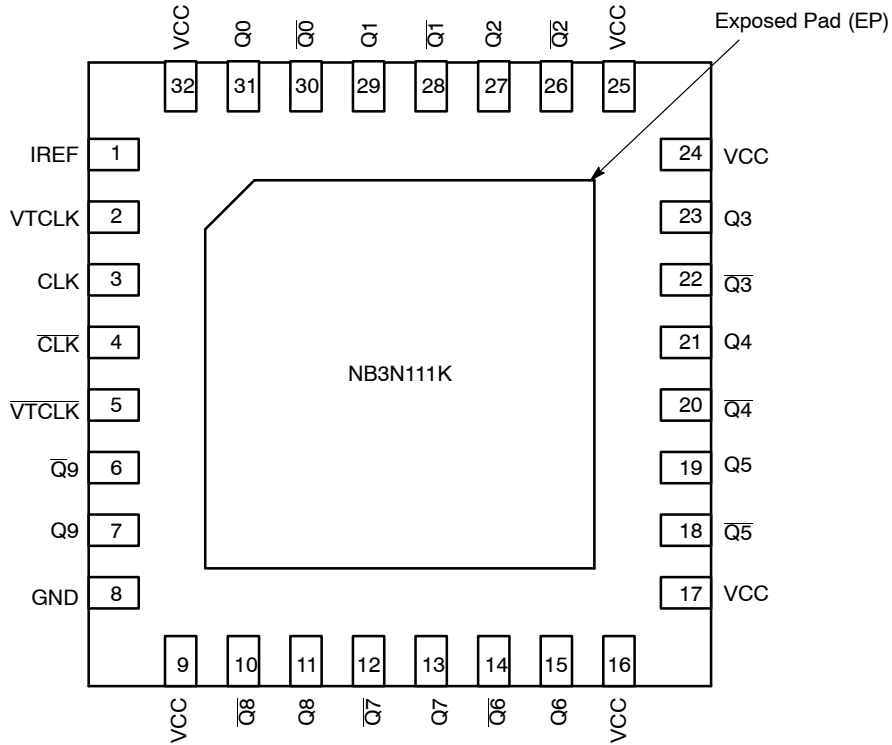

Figure 2. Pinout Configuration (Top View)

Table 1. PIN DESCRIPTION

Pin	Name	I/O	Description
1	IREF		Use the IREF pin to set the output drive. Connect a 475 Ω RREF resistor from the IREF pin to GND to produce 2.6 mA of IREF current. A current mirror multiplies IREF by a factor of 5.4x to force 14 mA through a 50 Ω output load. See Figures 6 and 12.
2, 5	VTCLK, VTCLK	-	Internal 50 Ω Termination Resistor connection Pins. In the differential configuration when the input termination pins are connected to the common termination voltage, and if no signal is applied then the device may be susceptible to self-oscillation.
3	CLK	LVPECL, HCSSL, LVDS Input	Clock and Data (TRUE) Input
4	$\overline{\text{CLK}}$	LVPECL, HCSSL, LVDS Input	Clock and Data (INVERT) Input
6, 10, 12, 14, 18, 20, 22, 26, 28, 30	$\overline{\text{Q}}[9-0]$	HCSSL or LVDS (Note 1) Output	Output (INVERT) (Note 1)
7, 11, 13, 15, 19, 21, 23, 27, 29, 31	Q[9-0]	HCSSL or LVDS (Note 1) Output	Output (TRUE) (Note 1)
8	GND	-	Supply Ground. GND pin must be externally connected to power supply to guarantee proper operation.
9, 16, 17, 24, 25, 32	VCC	-	Positive Voltage Supply pin. VCC pins must be externally connected to a power supply to guarantee proper operation.
Exposed Pad	EP	GND	Exposed Pad. The thermally exposed pad (EP) on package bottom (see case drawing) must be attached to a sufficient heat-sinking conduit for proper thermal operation and electrically connected to the circuit board ground (GND).

1. Outputs can also interface to LVDS receiver when terminated per Figure 11.

NB3N111K

Table 2. ATTRIBUTES

Characteristic	Value
ESD Protection Human Body Model Machine Model	>2 kV 200 V
Moisture Sensitivity (Note 2) QFN32	Level 1
Flammability Rating Oxygen Index: 28 to 34	UL 94 V-0 @ 0.125 in
Transistor Count	286
Meets or exceeds JEDEC Spec EIA/JESD78 IC Latchup Test	

2. For additional information, see Application Note [AND8003/D](#).

Table 3. MAXIMUM RATINGS (Note 3)

Symbol	Parameter	Condition 1	Condition 2	Rating	Unit
V_{CC}	Positive Power Supply	GND = 0 V		4.6	V
V_I	Positive Input	GND = 0 V		$GND - 0.3 \leq V_I \leq V_{CC}$	V
VINPP	Differential Input Voltage			V_{CC}	V
I_{OUT}	Output Current	Continuous Surge		50 100	mA mA
T_A	Operating Temperature Range	QFN32		-40 to +85	°C
T_{stg}	Storage Temperature Range			-65 to +150	°C
θ_{JA}	Thermal Resistance (Junction-to-Ambient) (Note 3)	0 lfpm 500 lfpm	QFN32 QFN32	31 27	°C/W °C/W
θ_{JC}	Thermal Resistance (Junction-to-Case)	2S2P (Note 3)	QFN32	12	°C/W
T_{sol}	Wave Solder Pb-Free			265	°C

Stresses exceeding those listed in the Maximum Ratings table may damage the device. If any of these limits are exceeded, device functionality should not be assumed, damage may occur and reliability may be affected.

3. JEDEC standard 51-6, multilayer board – 2S2P (2 signal, 2 power) with 8 filled thermal vias under exposed pad.

NB3N111K

Table 4. DC CHARACTERISTICS ($V_{CC} = 3.0\text{ V to }3.6\text{ V}$, $T_A = -40^\circ\text{C to }+85^\circ\text{C}$ Note 4)

Symbol	Characteristic	Min	Typ	Max	Unit
I_{GND}	GND Supply Current (All Outputs Loaded)		60	90	mA
I_{CC}	Power Supply Current (All Outputs Loaded)		210	260	mA
I_{IH}	Input HIGH Current		2.0	150	μA
I_{IL}	Input LOW Current	-150	-2.0		μA
R_{TIN}	Internal Input Termination Resistor	45	50	55	Ω

DIFFERENTIAL INPUT DRIVEN SINGLE-ENDED

V_{th}	Input Threshold Reference Voltage Range (Note 5)	350		$V_{CC} - 1000$	mV
V_{IH}	Single – Ended Input HIGH Voltage	$V_{th} + 150$		V_{CC}	mV
V_{IL}	Single – Ended Input LOW Voltage	GND		$V_{th} - 150$	mV

DIFFERENTIAL INPUTS DRIVEN DIFFERENTIALLY (Figures 7, 8 and 9)

V_{IHD}	Differential Input HIGH Voltage	425		$V_{CC} - 850$	mV
V_{ILD}	Differential Input LOW Voltage	GND		$V_{CC} - 1000$	mV
V_{ID}	Differential Input Voltage ($V_{IHD} - V_{ILD}$)	150		$V_{CC} - 850$	mV
V_{CMR}	Input Common Mode Range	350		$V_{CC} - 1000$	mV

HCSL OUTPUTS (Figure 4)

V_{OH}	Output HIGH Voltage	600	740	900	mV
V_{OL}	Output LOW Voltage	-150	0	150	mV

NOTE: Device will meet the specifications after thermal equilibrium has been established when mounted in a test socket or printed circuit board with maintained transverse airflow greater than 500 lfm.

- Measurements taken with outputs loaded 50 Ω to GND. Connect a 475 Ω resistor from IREF (Pin 1) to GND. See Figure 6.
- V_{th} is applied to the complementary input when operating in single ended mode per Figure 4.

NB3N111K

Table 5. AC CHARACTERISTICS $V_{CC} = 3.0\text{ V to }3.6\text{ V}$, $GND = 0\text{ V}$; $-40^{\circ}\text{C to }+85^{\circ}\text{C}$ (Note 6)

Symbol	Characteristic	Min	Typ	Max	Unit	
V_{OUTPP}	Output Voltage Amplitude (@ $V_{INPPmin}$) $f_{in} \leq 400\text{ MHz}$		725	1000	mV	
t_{PLH} , t_{PHL}	Propagation Delay (See Figure 3a) CLK/CLK to Q_x/\bar{Q}_x	550	800	1100	ps	
Δt_{PLH} , Δt_{PHL}	Propagation Delay Variation Per Each Diff Pair (Note 7) (See Figure 3a) CLK/ \bar{CLK} to Q_x/\bar{Q}_x			100	ps	
t_{SKEW}	Duty Cycle Skew (Note 8) Within –Device Skew Device to Device Skew (Note 9)			20 100 150	ps	
$t_{JT\theta}$	Additive Integrated Phase Jitter at $F_c = 100\text{ MHz}$ (Note 10)		0.1		ps	
V_{INPP}	Input Voltage Swing/Sensitivity (Differential Configuration)	0.150		$V_{CC} - 0.85$	V	
V_{CROSS}	Absolute Crossing Magnitude Voltage (See Figure 3b)	250		550	mV	
ΔV_{CROSS}	Variation in Magnitude of V_{CROSS} (See Figure 3b)			150	mV	
t_r, t_f	Absolute Magnitude in Output Risetime and Falltime (from 175 mV to 525 mV) (See Figure 3b)	Q_x, \bar{Q}_x	150	220	400	ps
$\Delta t_r, \Delta t_f$	Variation in Magnitude of Risetime and Falltime (Single-Ended) (See Figure 3b)	Q_x, \bar{Q}_x			125	ps

NOTE: Device will meet the specifications after thermal equilibrium has been established when mounted in a test socket or printed circuit board with maintained transverse airflow greater than 500 lfm.

6. Measured by forcing V_{INPP} (MIN) from a 50% duty cycle. Measurement taken with all outputs loaded $50\ \Omega$ to GND. Connect a $475\ \Omega$ resistor from IREF (Pin 1) to GND. See Figure 6.
7. Measured from the input pair crosspoint to each single output pair crosspoint across temp and voltage ranges per Figure 3.
8. Duty cycle skew is measured between differential outputs using the deviations of the sum of T_{pw-} and T_{pw+} .
9. Skew is measured between outputs under identical transition conditions @ 50 MHz.
10. Phase noise integrated from 12 kHz to 20 MHz.

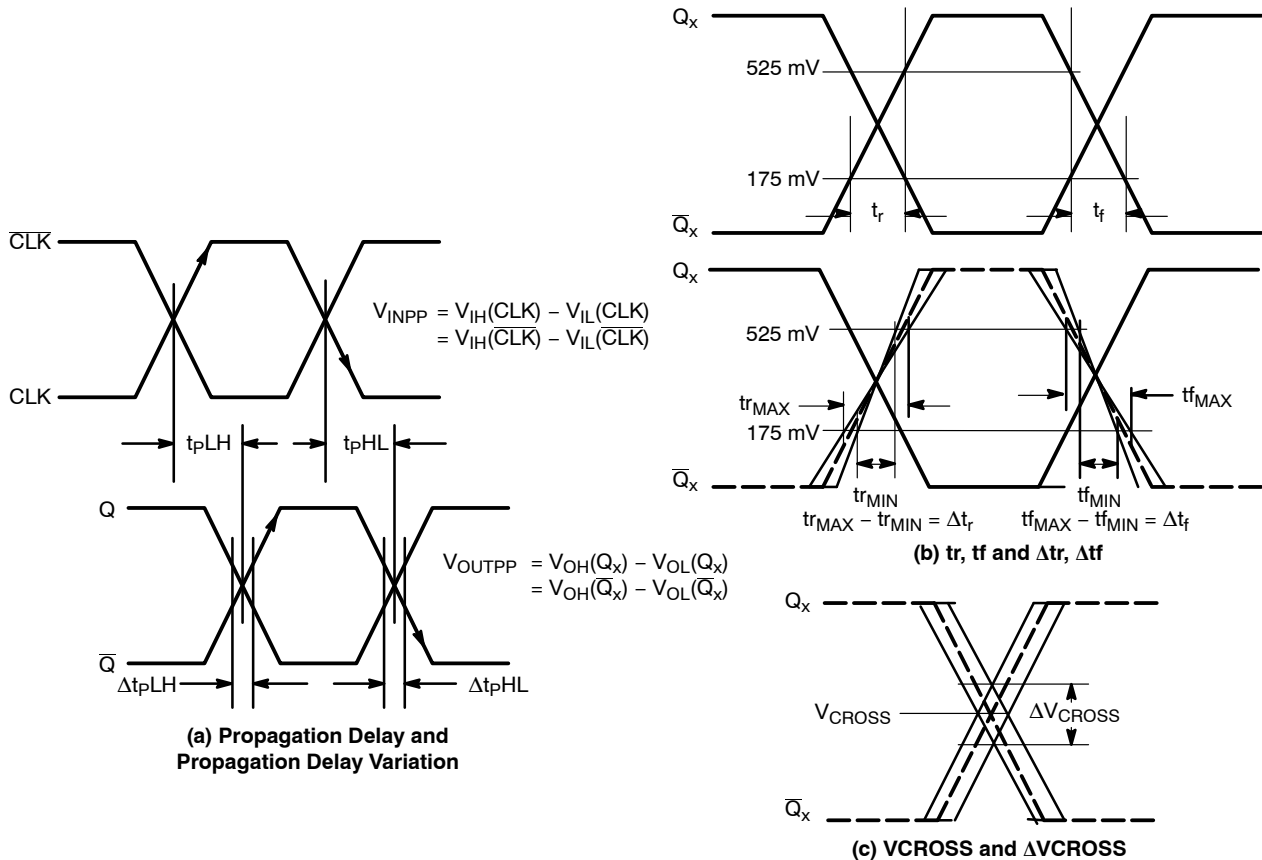

Figure 3. AC Reference Measurement

NB3N111K

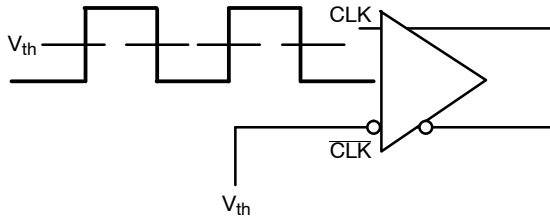

Figure 4. Single-Ended Interconnect V_{th} Reference Voltage

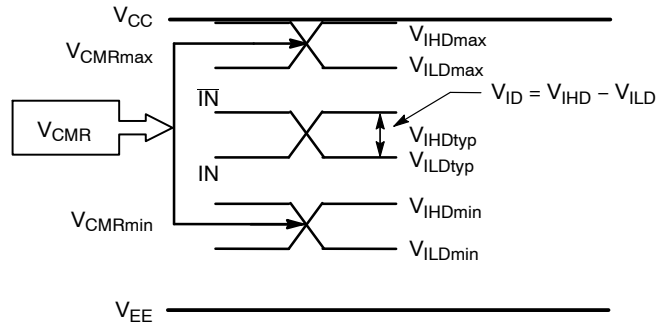
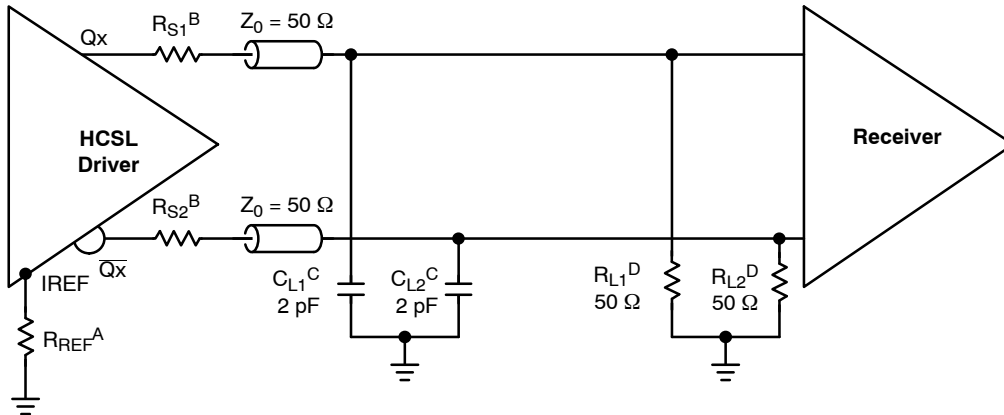
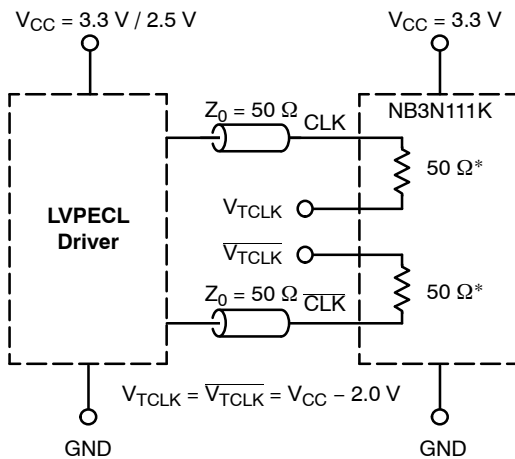

Figure 5. V_{th} Diagram



- A. Connect 475 Ω resistor R_{REF} from IREF pin to GND.
- B. R_{S1} , R_{S2} : 0 Ω for Test and Evaluation. Select to Minimizing Ringing.
- C. C_{L1} , C_{L2} : Receiver Input Simulation (for test only not added to application circuit) Load capacitance only.
- D. D_{L1} , D_{L2} Termination and Load Resistors Located at Receiver Inputs.

Figure 6. Typical Termination Configuration for Output Driver and Device Evaluation



*RTIN, Internal Input Termination Resistor

Figure 7. LVPECL Interface

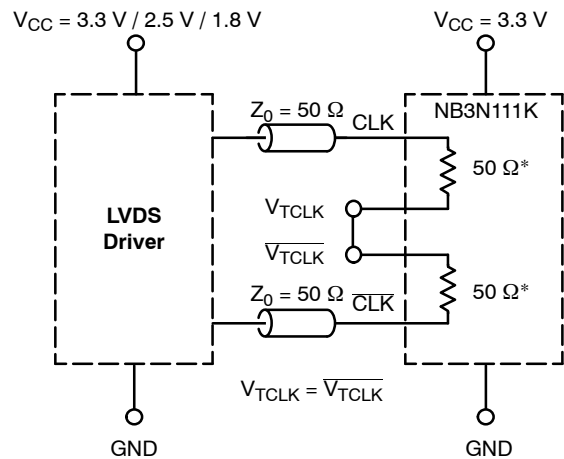

*RTIN, Internal Input Termination Resistor

Figure 8. LVDS Interface

NB3N111K

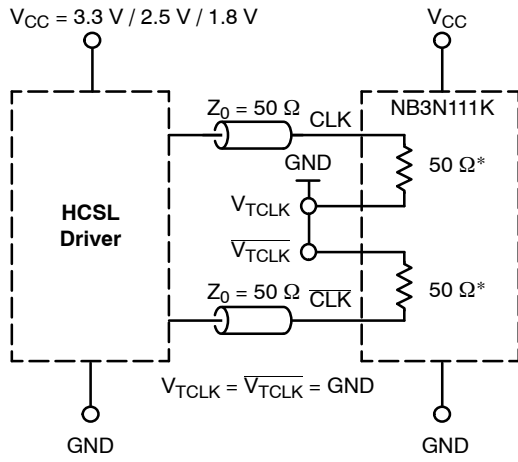

*RTIN, Internal Input Termination Resistor

Figure 9. Standard 50 Ω Load HCSL Interface

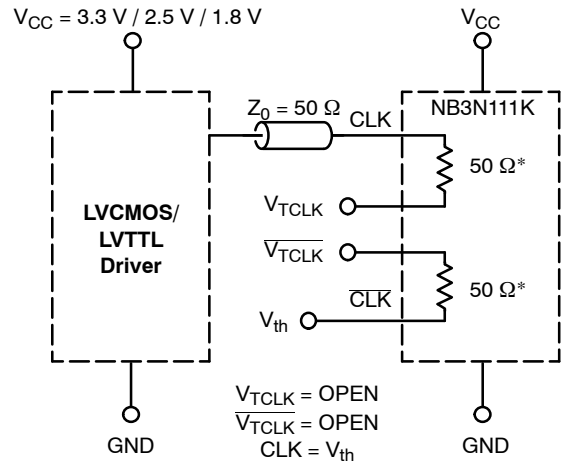

*RTIN, Internal Input Termination Resistor

Figure 10. LVCMOS/LVTTL Interface

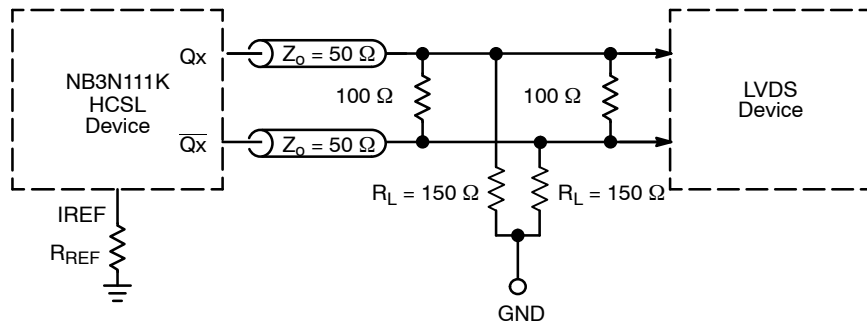

Figure 11. HCSL Interface Termination to LVDS

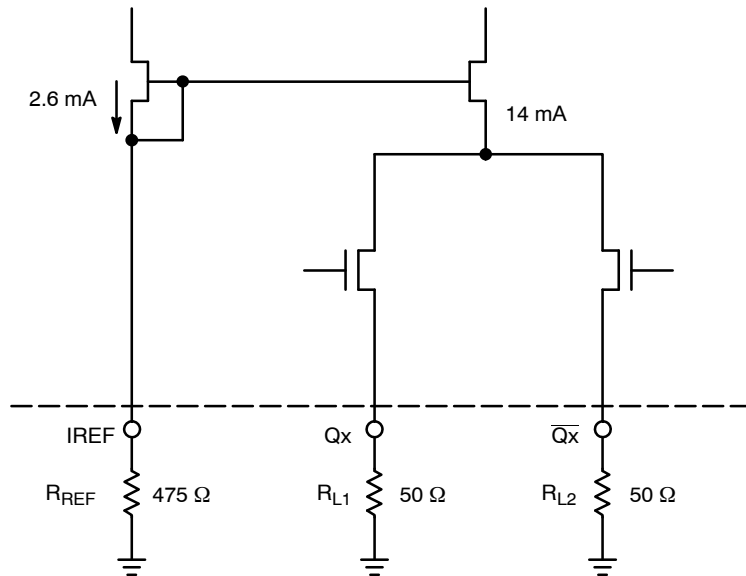

Figure 12. HCSL Simplified Output Structure

NB3N111K

ORDERING INFORMATION

Device	Package	Shipping†
NB3N111KMNR4G	QFN32 (Pb-Free)	1000 / Tape & Reel

†For information on tape and reel specifications, including part orientation and tape sizes, please refer to our Tape and Reel Packaging Specifications Brochure, [BRD8011/D](#).

MECHANICAL CASE OUTLINE

PACKAGE DIMENSIONS

ON Semiconductor®

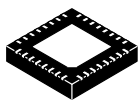

1 32

SCALE 2:1

QFN32 5x5, 0.5P
CASE 488AM
ISSUE A

DATE 23 OCT 2013

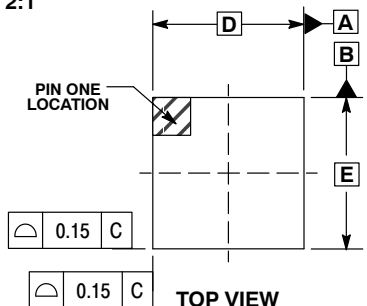

TOP VIEW

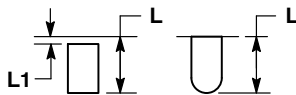

DETAIL A
ALTERNATE TERMINAL
CONSTRUCTIONS

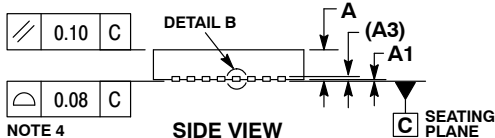

SIDE VIEW

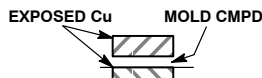

DETAIL B
ALTERNATE
CONSTRUCTION

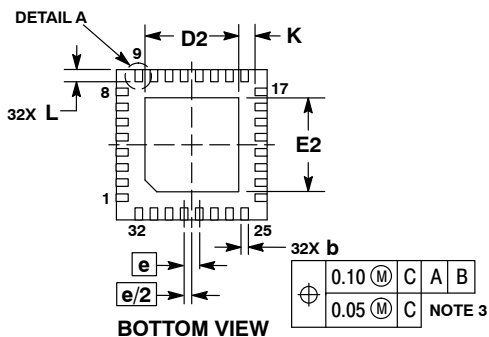

BOTTOM VIEW

NOTES:

1. DIMENSIONS AND TOLERANCING PER ASME Y14.5M, 1994.
2. CONTROLLING DIMENSION: MILLIMETERS.
3. DIMENSION b APPLIES TO PLATED TERMINAL AND IS MEASURED BETWEEN 0.15 AND 0.30MM FROM THE TERMINAL TIP. COPLANARITY APPLIES TO THE EXPOSED PAD AS WELL AS THE TERMINALS.
4. COPLANARITY APPLIES TO THE EXPOSED PAD AS WELL AS THE TERMINALS.

MILLIMETERS		
DIM	MIN	MAX
A	0.80	1.00
A1	---	0.05
A3	0.20	REF
b	0.18	0.30
D	5.00	BSC
D2	2.95	3.25
E	5.00	BSC
E2	2.95	3.25
e	0.50	BSC
K	0.20	---
L	0.30	0.50
L1	---	0.15

GENERIC MARKING DIAGRAM*

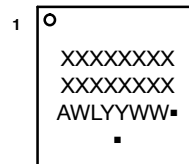

- XXXXXX = Specific Device Code
- A = Assembly Location
- WL = Wafer Lot
- YY = Year
- WW = Work Week
- = Pb-Free Package

(Note: Microdot may be in either location)
*This information is generic. Please refer to device data sheet for actual part marking.
Pb-Free indicator, "G" or microdot "▪", may or may not be present.

RECOMMENDED SOLDERING FOOTPRINT*

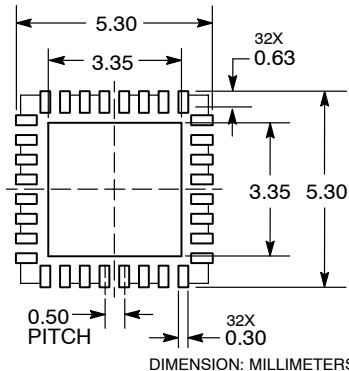

*For additional information on our Pb-Free strategy and soldering details, please download the ON Semiconductor Soldering and Mounting Techniques Reference Manual, SOLDERRM/D.

DOCUMENT NUMBER:	98AON20032D	Electronic versions are uncontrolled except when accessed directly from the Document Repository. Printed versions are uncontrolled except when stamped "CONTROLLED COPY" in red.
DESCRIPTION:	QFN32 5x5 0.5P	PAGE 1 OF 1

ON Semiconductor and ON are trademarks of Semiconductor Components Industries, LLC dba ON Semiconductor or its subsidiaries in the United States and/or other countries. ON Semiconductor reserves the right to make changes without further notice to any products herein. ON Semiconductor makes no warranty, representation or guarantee regarding the suitability of its products for any particular purpose, nor does ON Semiconductor assume any liability arising out of the application or use of any product or circuit, and specifically disclaims any and all liability, including without limitation special, consequential or incidental damages. ON Semiconductor does not convey any license under its patent rights nor the rights of others.

onsemi, **Onsemi**, and other names, marks, and brands are registered and/or common law trademarks of Semiconductor Components Industries, LLC dba "**onsemi**" or its affiliates and/or subsidiaries in the United States and/or other countries. **onsemi** owns the rights to a number of patents, trademarks, copyrights, trade secrets, and other intellectual property. A listing of **onsemi**'s product/patent coverage may be accessed at www.onsemi.com/site/pdf/Patent-Marking.pdf. **onsemi** reserves the right to make changes at any time to any products or information herein, without notice. The information herein is provided "as-is" and **onsemi** makes no warranty, representation or guarantee regarding the accuracy of the information, product features, availability, functionality, or suitability of its products for any particular purpose, nor does **onsemi** assume any liability arising out of the application or use of any product or circuit, and specifically disclaims any and all liability, including without limitation special, consequential or incidental damages. Buyer is responsible for its products and applications using **onsemi** products, including compliance with all laws, regulations and safety requirements or standards, regardless of any support or applications information provided by **onsemi**. "Typical" parameters which may be provided in **onsemi** data sheets and/or specifications can and do vary in different applications and actual performance may vary over time. All operating parameters, including "Typicals" must be validated for each customer application by customer's technical experts. **onsemi** does not convey any license under any of its intellectual property rights nor the rights of others. **onsemi** products are not designed, intended, or authorized for use as a critical component in life support systems or any FDA Class 3 medical devices or medical devices with a same or similar classification in a foreign jurisdiction or any devices intended for implantation in the human body. Should Buyer purchase or use **onsemi** products for any such unintended or unauthorized application, Buyer shall indemnify and hold **onsemi** and its officers, employees, subsidiaries, affiliates, and distributors harmless against all claims, costs, damages, and expenses, and reasonable attorney fees arising out of, directly or indirectly, any claim of personal injury or death associated with such unintended or unauthorized use, even if such claim alleges that **onsemi** was negligent regarding the design or manufacture of the part. **onsemi** is an Equal Opportunity/Affirmative Action Employer. This literature is subject to all applicable copyright laws and is not for resale in any manner.

ADDITIONAL INFORMATION

TECHNICAL PUBLICATIONS:



Technical Library: www.onsemi.com/design/resources/technical-documentation
onsemi Website: www.onsemi.com

ONLINE SUPPORT: www.onsemi.com/support

For additional information, please contact your local Sales Representative at www.onsemi.com/support/sales

Looking for pricing, stock, or lifecycle information?

Click below to explore more details on WIN SOURCE:

-  [View NB3N111KMNR4G on WIN SOURCE](#)
-  [ON Semiconductor Information](#)

Optimize Your Supply Chain with WIN SOURCE Solutions

-  Global Sourcing Solution
-  Obsolete Management
-  Cost Control Management
-  Shortage Management
-  Alternative Solution
-  Excess Inventory Management