



**THE DATASHEET OF
ZL40218LDG1**



Features

Inputs/Outputs

- Accepts differential or single-ended input
 - LVPECL, LVDS, CML, HCSL, LVCMOS
- Eight precision LVDS outputs
- Operating frequency up to 750 MHz

Power

- Option for 2.5 V or 3.3 V power supply
- Current consumption of 106 mA
- On-chip Low Drop Out (LDO) Regulator for superior power supply noise rejection

Performance

- Ultra low additive jitter of 104 fs RMS

Ordering Information

ZL40218LDG1	32 Pin QFN	Trays
ZL40218LDF1	32 Pin QFN	Tape and Reel
Matte Tin		
Package Size: 5 x 5 mm		
-40°C to +85°C		

Applications

- General purpose clock distribution
- Low jitter clock trees
- Logic translation
- Clock and data signal restoration
- Wired communications: OTN, SONET/SDH, GE, 10 GE, FC and 10G FC
- Wireless communications
- High performance micro-processor clock distribution

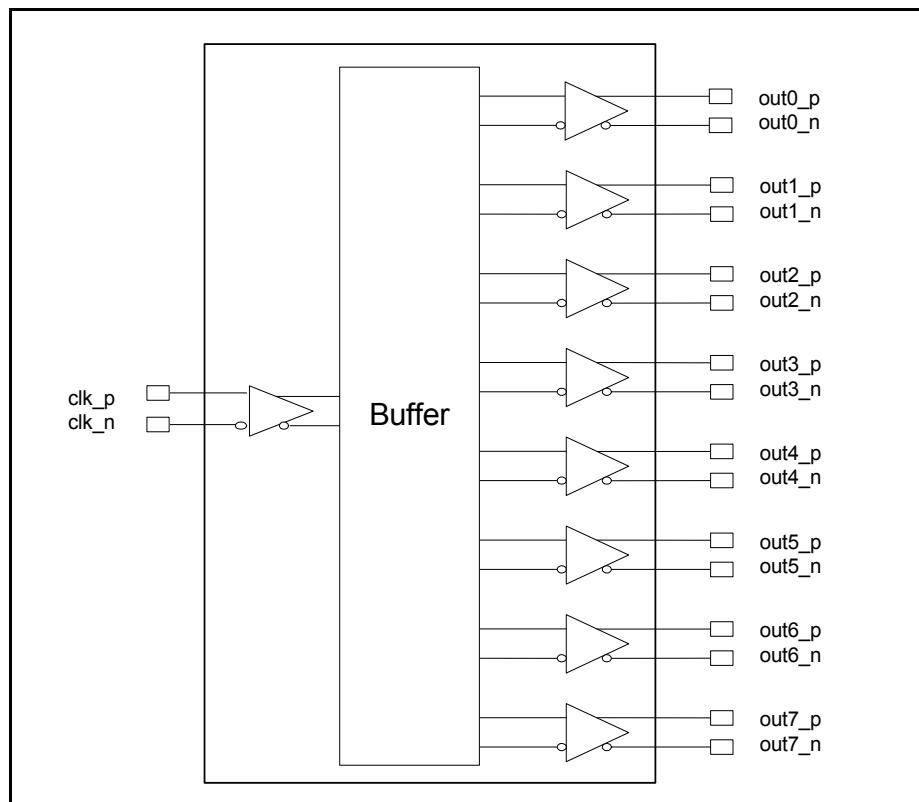

Figure 1 - Functional Block Diagram

Table of Contents

Features	1
Inputs/Outputs	1
Power	1
Performance	1
Applications	1
1.0 Package Description	4
2.0 Pin Description	5
3.0 Functional Description	6
3.1 Clock Inputs	6
3.2 Clock Outputs	11
3.3 Device Additive Jitter	14
3.4 Power Supply	15
3.4.1 Sensitivity to power supply noise	15
3.4.2 Power supply filtering	15
3.4.3 PCB layout considerations	15
4.0 AC and DC Electrical Characteristics	16
5.0 Performance Characterization	18
6.0 Typical Behavior	19
7.0 Package Characteristics	20
8.0 Mechanical Drawing	21

List of Figures

Figure 1 - Functional Block Diagram	1
Figure 2 - Pin Connections	4
Figure 3 - LVPECL Input DC Coupled Thevenin Equivalent	6
Figure 4 - LVPECL Input DC Coupled Parallel Termination	7
Figure 5 - LVPECL Input AC Coupled Termination	7
Figure 6 - LVDS Input DC Coupled	8
Figure 7 - LVDS Input AC Coupled	8
Figure 8 - CML Input AC Coupled	9
Figure 9 - HCSL Input AC Coupled	9
Figure 10 - CMOS Input DC Coupled Referenced to VDD/2	10
Figure 11 - CMOS Input DC Coupled Referenced to Ground	10
Figure 12 - Simplified LVDS Output Driver	11
Figure 13 - LVDS DC Coupled Termination (Internal Receiver Termination)	11
Figure 14 - LVDS DC Coupled Termination (External Receiver Termination)	12
Figure 15 - LVDS AC Coupled Termination	12
Figure 16 - LVDS AC Output Termination for CML Inputs	13
Figure 17 - Additive Jitter	14
Figure 18 - Decoupling Connections for Power Pins	15
Figure 19 - Differential Voltage Parameter	17
Figure 20 - Input To Output Timing	17

1.0 Package Description

The device is packaged in a 32 pin QFN

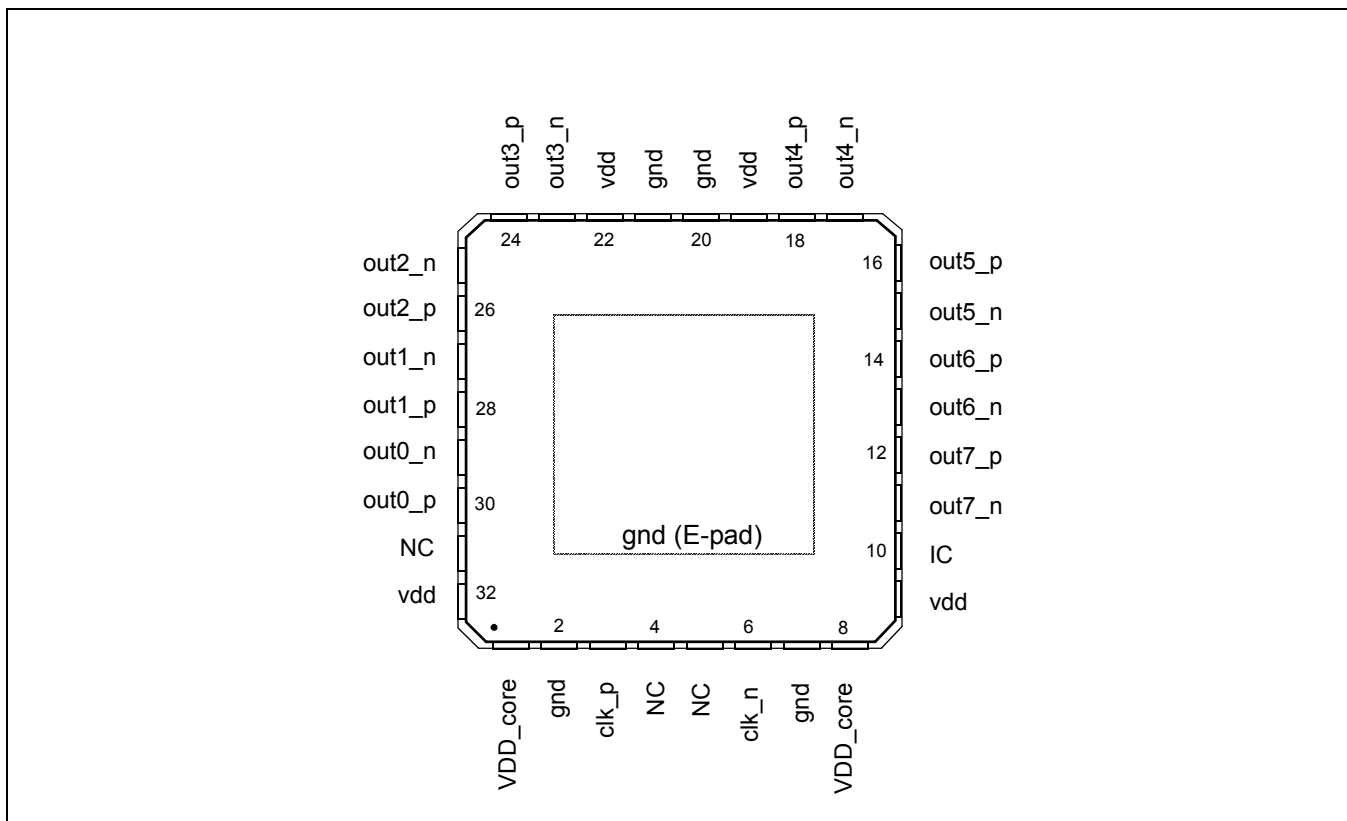

Figure 2 - Pin Connections

2.0 Pin Description

Pin #	Name	Description
3, 6	clk_p, clk_n,	Differential Input (Analog Input). Differential (or single ended) input signals. For all input configurations see section 3.1, "Clock Inputs".
30, 29, 28, 27, 26, 25, 24, 23, 18, 17, 16, 15, 14, 13, 12, 11	out0_p, out0_n out1_p, out1_n out2_p, out2_n out3_p, out3_n out4_p, out4_n out5_p, out5_n out6_p, out6_n out7_p, out7_n	Differential Output (Analog Output). Differential outputs.
9, 19, 22, 32	vdd	Positive Supply Voltage. 2.5 V _{DC} or 3.3 V _{DC} nominal.
1, 8	vdd_core	Positive Supply Voltage. 2.5 V _{DC} or 3.3 V _{DC} nominal.
2, 7, 20, 21	gnd	Ground. 0 V.
4, 5 10, 31	NC	No Connection. Leave unconnected.

3.0 Functional Description

The ZL40218 is an LVDS clock fanout buffer with eight identical output clock drivers capable of operating at frequencies up to 750MHz.

Inputs to the ZL40218 are externally terminated to allow use of precision termination components and to allow full flexibility of input termination. The ZL40218 can accept DC or AC coupled LVPECL, LVDS, CML or HCSL input signals; single ended input signals can also be accepted. A pin compatible device with internal termination is also available.

The ZL40218 is designed to fan out low-jitter reference clocks for wired or optical communications applications while adding minimal jitter to the clock signal. An internal linear power supply regulator and bulk capacitors minimize additive jitter due to power supply noise. The device operates from 2.5V \pm 5% or 3.3V \pm 5% supply. Its operation is guaranteed over the industrial temperature range -40°C to +85°C.

The device block diagram is shown in Figure 1; its operation is described in the following sections.

3.1 Clock Inputs

The ZL40218 is adaptable to support different types of differential and single-ended input signals depending on the passive components used in the input termination. The application diagrams in the following figures allow the ZL40218 to accept LVPECL, LVDS, CML, HCSL and single-ended inputs.

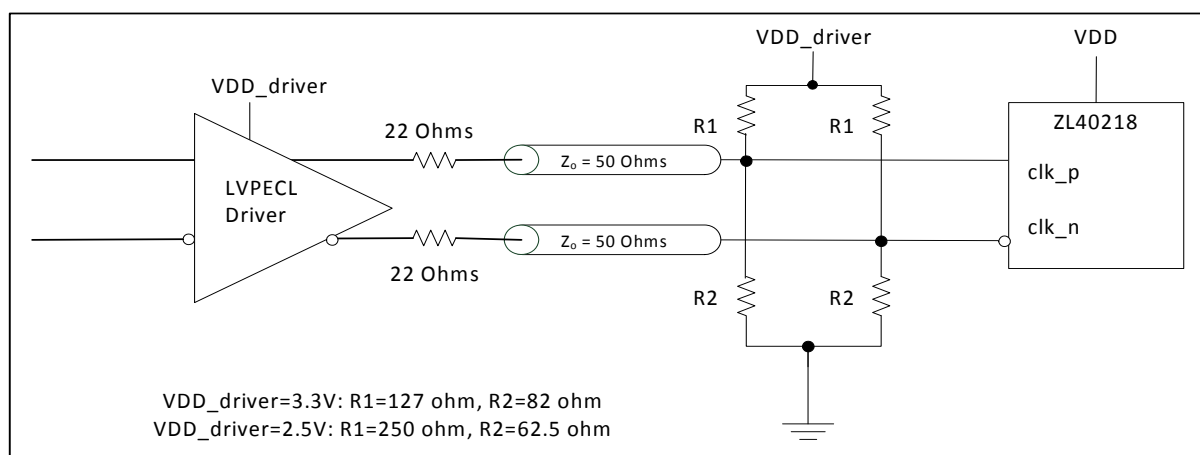

Figure 3 - LVPECL Input DC Coupled Thevenin Equivalent

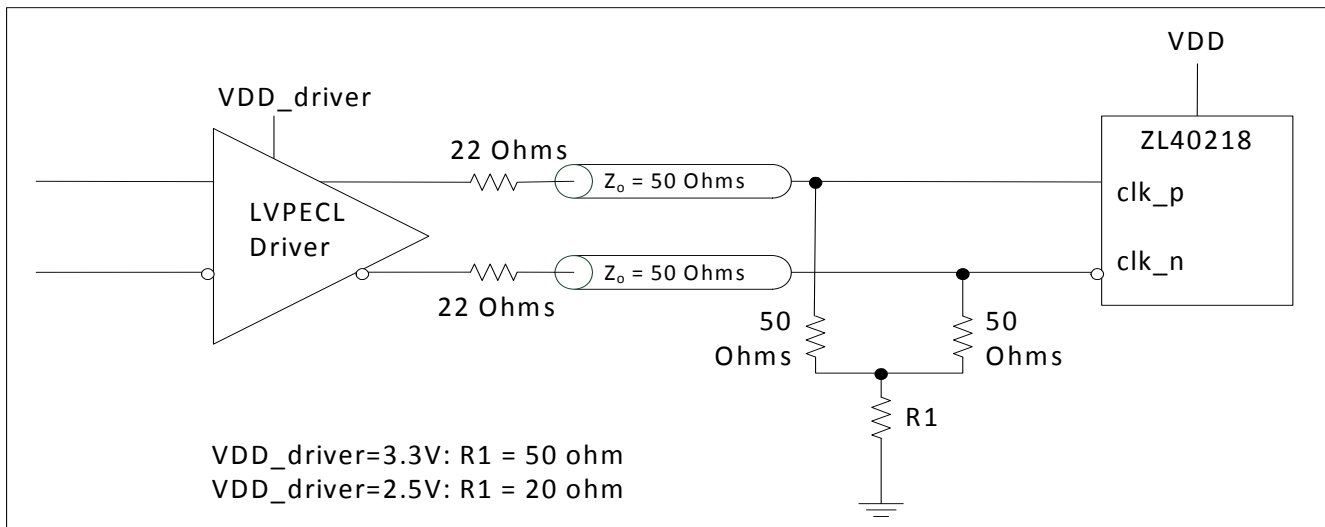

Figure 4 - LVPECL Input DC Coupled Parallel Termination

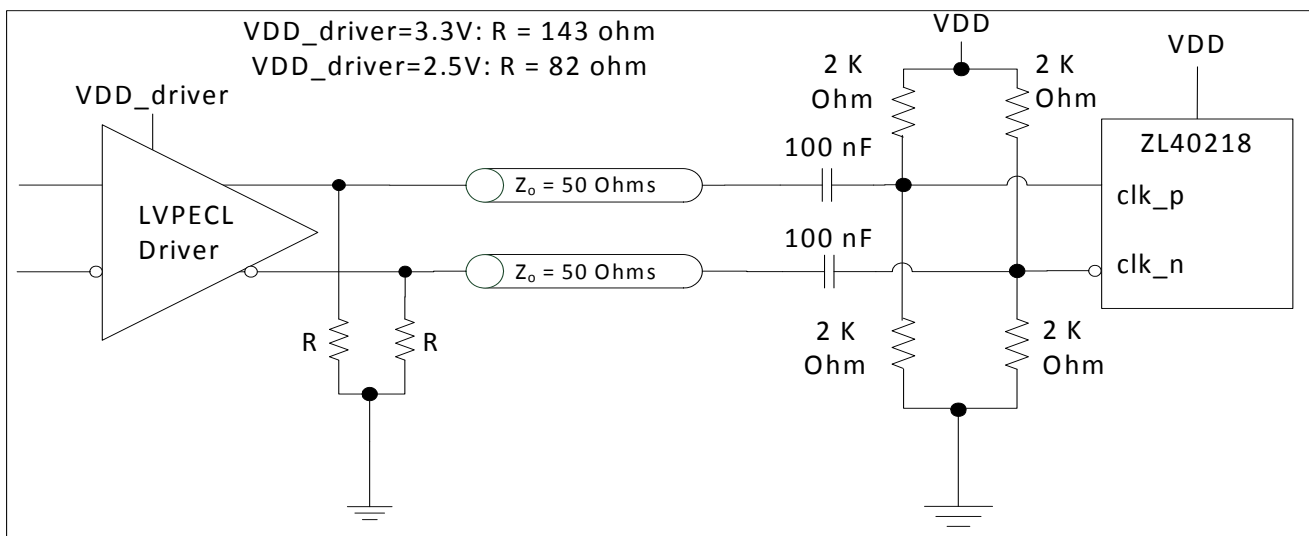

Figure 5 - LVPECL Input AC Coupled Termination

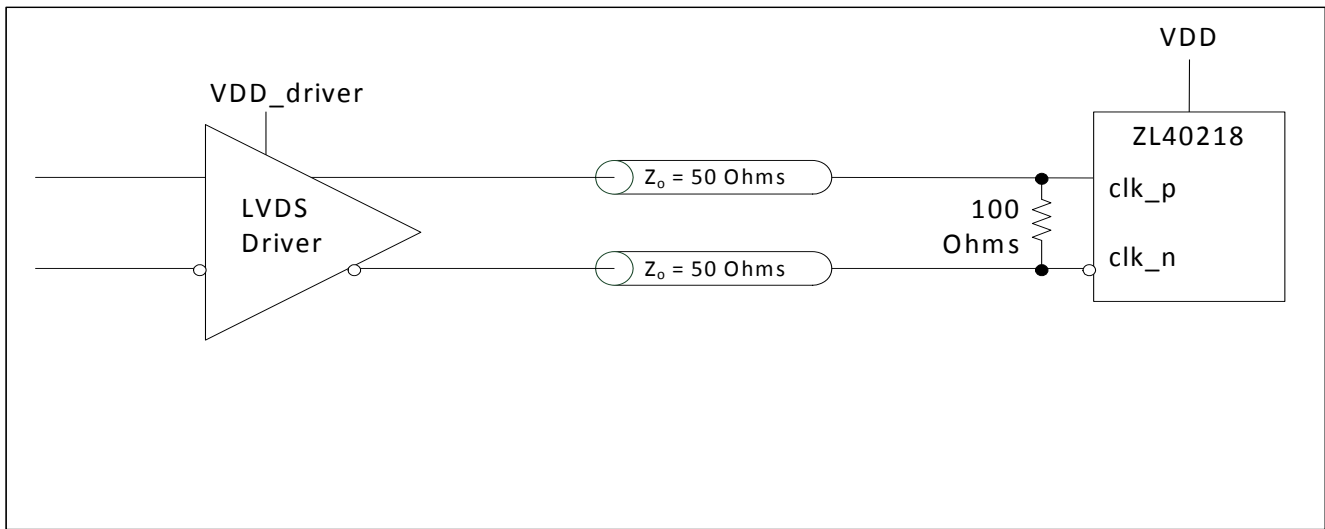

Figure 6 - LVDS Input DC Coupled

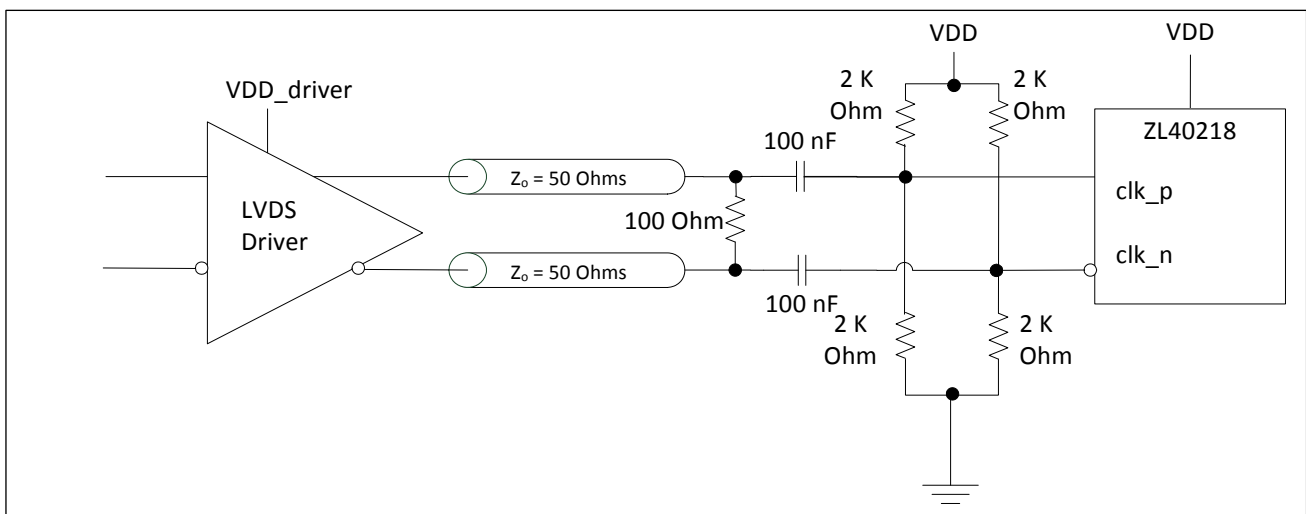

Figure 7 - LVDS Input AC Coupled

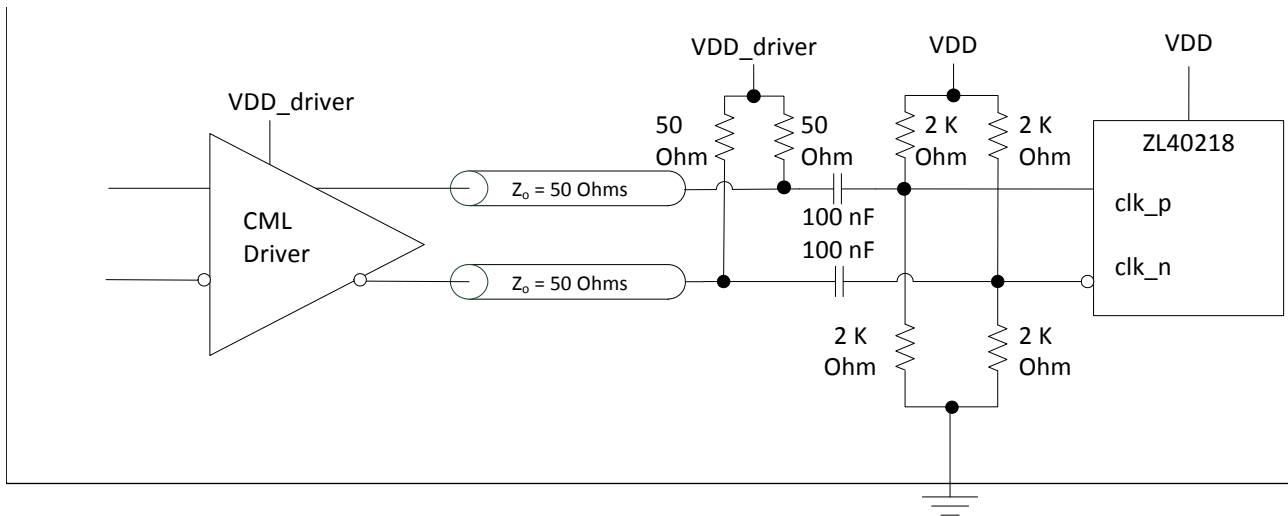

Figure 8 - CML Input AC Coupled

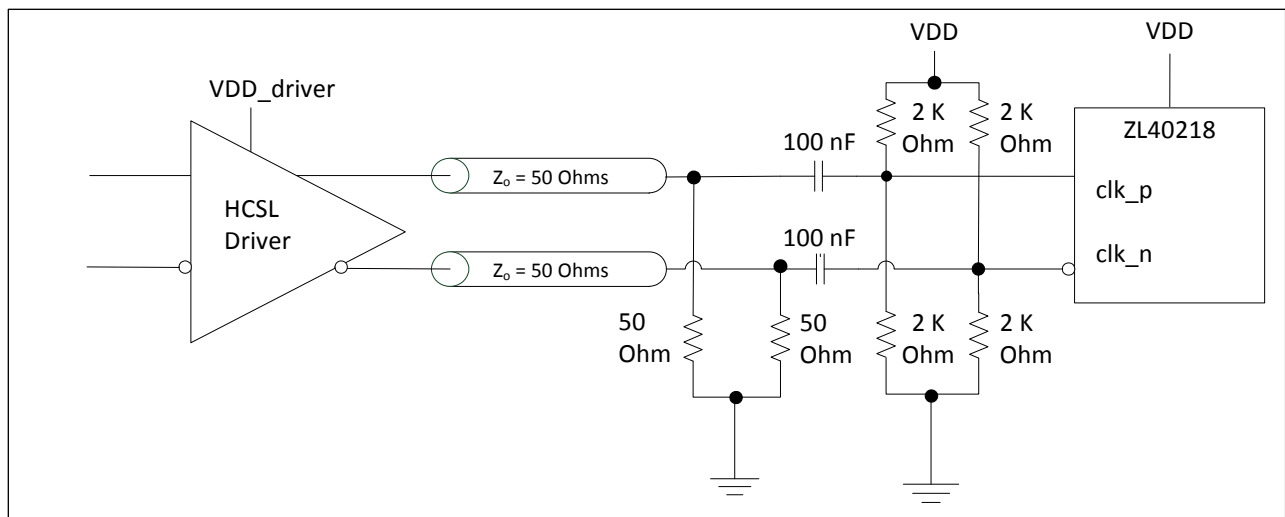

Figure 9 - HCSL Input AC Coupled

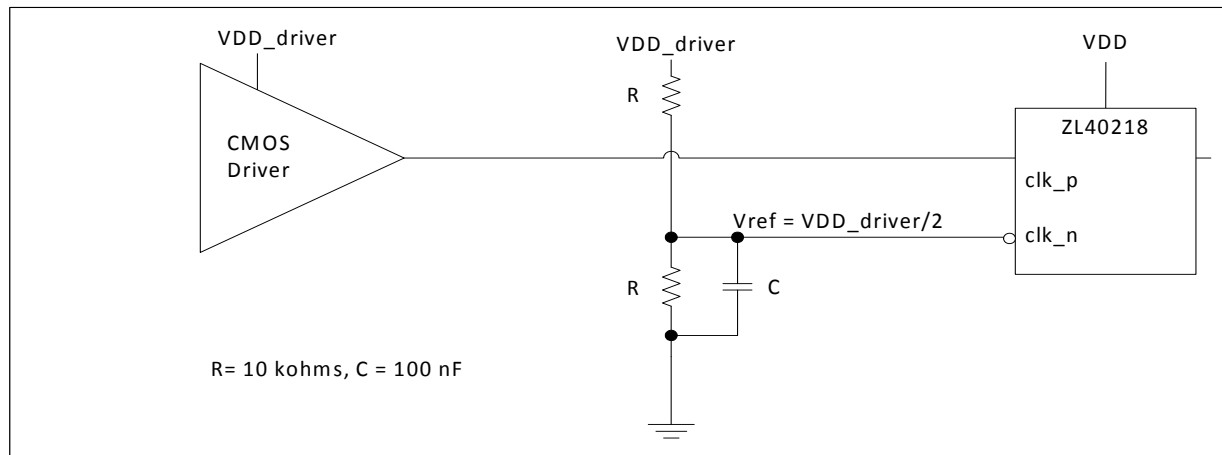

Figure 10 - CMOS Input DC Coupled Referenced to VDD/2

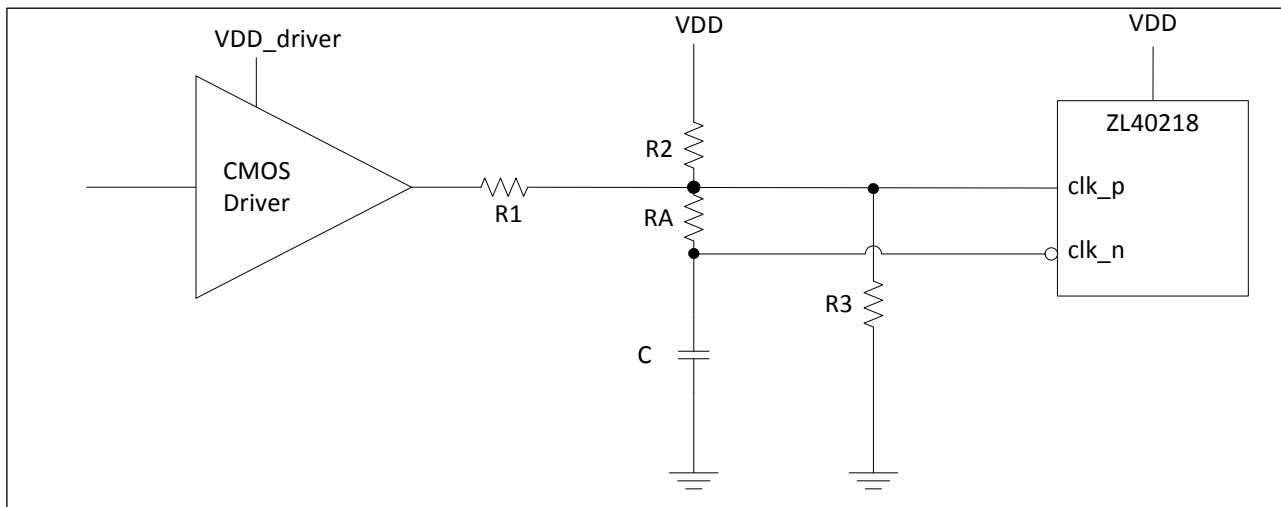

Figure 11 - CMOS Input DC Coupled Referenced to Ground

VDD_driver	R1 (kΩ)	R2 (kΩ)	R3 (kΩ)	RA (kΩ)	C (pF)
1.5	1.25	3.075	open	10	10
1.8	1	3.8	open	10	10
2.5	0.33	4.2	open	10	10
3.3	0.75	open	4.2	10	10

Table 1 - Component Values for Single Ended Input Reference to Ground

* For frequencies below 100 MHz, increase C to avoid signal integrity issues.

3.2 Clock Outputs

LVDS has lower signal swing than LVPECL which results in a low power consumption. A simplified diagram for the LVDS output stage is shown in Figure 12.

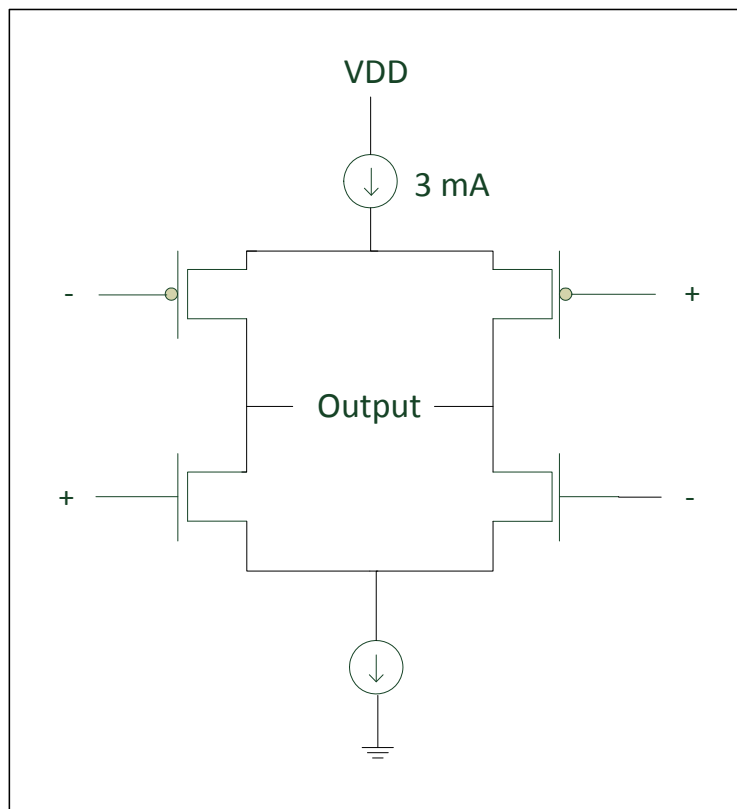

The methods to terminate the ZL40218 drivers are shown in the following figures.

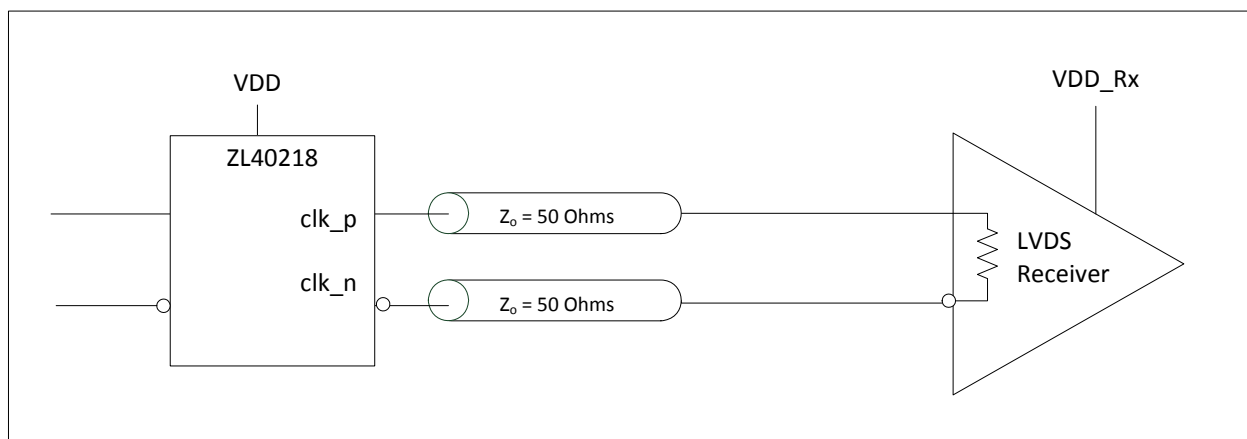

Figure 13 - LVDS DC Coupled Termination (Internal Receiver Termination)

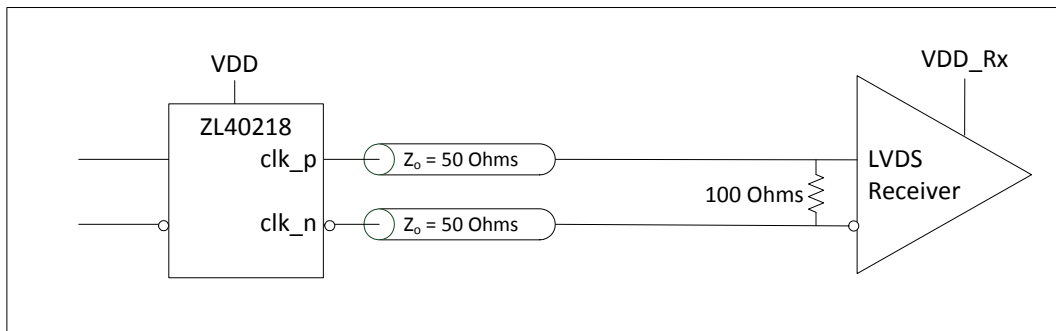

Figure 14 - LVDS DC Coupled Termination (External Receiver Termination)

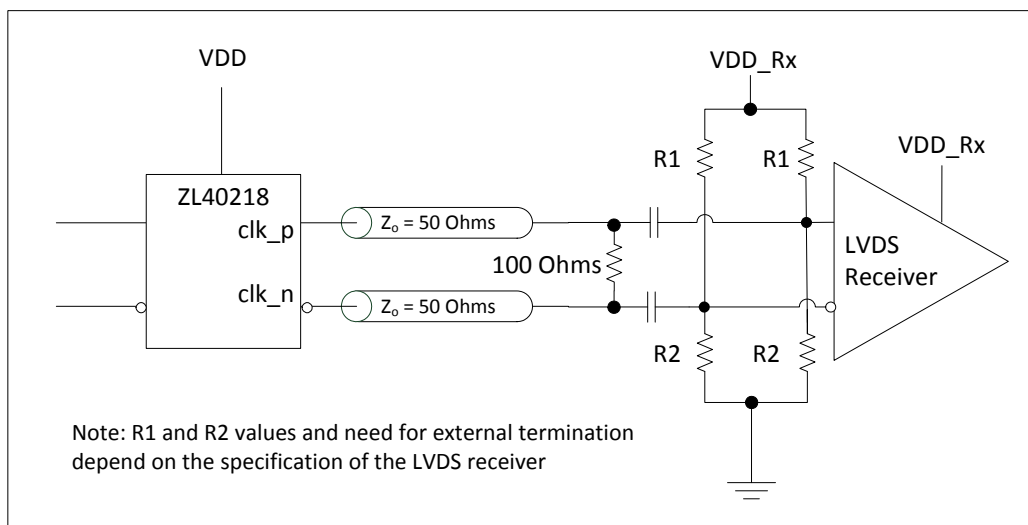

Figure 15 - LVDS AC Coupled Termination

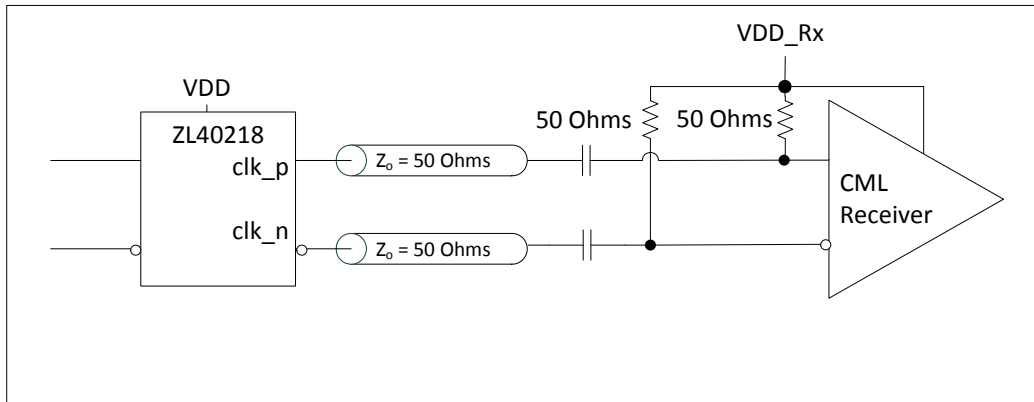

Figure 16 - LVDS AC Output Termination for CML Inputs

3.3 Device Additive Jitter

The ZL40218 clock fanout buffer is not intended to filter clock jitter. The jitter performance of this type of device is characterized by its additive jitter. Additive jitter is the jitter the device would add to a hypothetical jitter-free clock as it passes through the device. The additive jitter of the ZL40218 is random and as such it is not correlated to the jitter of the input clock signal.

The square of the resultant random RMS jitter at the output of the ZL40218 is equal to the sum of the squares of the various random RMS jitter sources including: input clock jitter; additive jitter of the buffer; and additive jitter due to power supply noise. There may be additional deterministic jitter sources, but they are not shown in Figure 17.

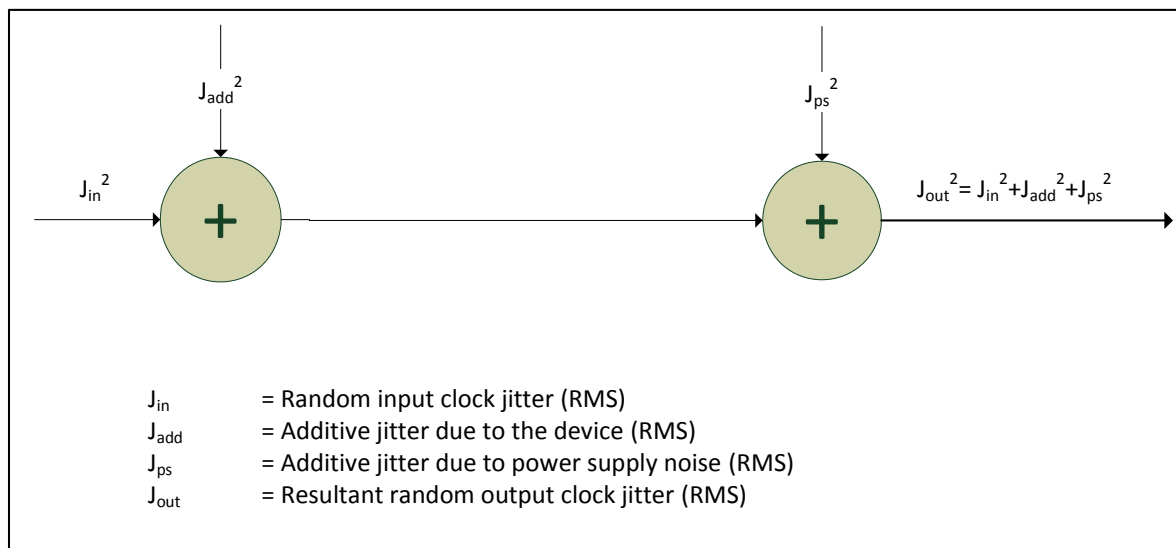

Figure 17 - Additive Jitter

3.4 Power Supply

This device operates employing either a 2.5V supply or 3.3V supply.

3.4.1 Sensitivity to power supply noise

Power supply noise from sources such as switching power supplies and high-power digital components such as FPGAs can induce additive jitter on clock buffer outputs. The ZL40218 is equipped with an on-chip linear power regulator and on-chip bulk capacitors to minimize additive jitter due to power supply noise. The on-chip measures in combination with the simple recommended power supply filtering and PCB layout are effective at minimizing additive jitter from power supply noise.

3.4.2 Power supply filtering

Jitter levels may increase when noise is present on the power pins. For optimal jitter performance, the device should be isolated from the power planes connected to its power supply pins as shown in Figure .

- 10 μF capacitors should be size 0603 or size 0805 X5R or X7R ceramic, 6.3 V minimum rating
- 0.1 μF capacitors should be size 0402 X5R ceramic, 6.3 V minimum rating
- Capacitors should be placed next to the connected device power pins
- A 0.3 ohm resistor is recommended

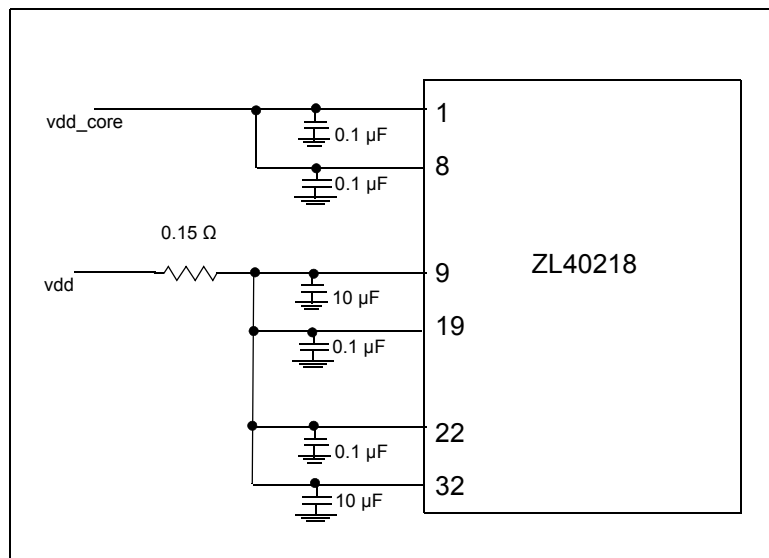

Figure 18 - Decoupling Connections for Power Pins

3.4.3 PCB layout considerations

The power nets in Figure can be implemented either as a plane island or routed power topology without changing the overall jitter performance of the device.

4.0 AC and DC Electrical Characteristics

Absolute Maximum Ratings*

	Parameter	Sym.	Min.	Max.	Units
1	Supply voltage	V_{DD_R}	-0.5	4.6	V
2	Voltage on any digital pin	V_{PIN}	-0.5	V_{DD}	V
3	Soldering temperature	T		260	°C
4	Storage temperature	T_{ST}	-55	125	°C
5	Junction temperature	T_j		125	°C
6	Voltage on input pin	V_{input}		V_{DD}	V
7	Input capacitance each pin	C_p		500	fF

* Exceeding these values may cause permanent damage. Functional operation under these conditions is not implied.

* Voltages are with respect to ground (GND) unless otherwise stated

Recommended Operating Conditions*

	Characteristics	Sym.	Min.	Typ.	Max.	Units
1	Supply voltage 2.5 V mode	V_{DD25}	2.375	2.5	2.625	V
2	Supply voltage 3.3 V mode	V_{DD33}	3.135	3.3	3.465	V
3	Operating temperature	T_A	-40	25	85	°C

* Voltages are with respect to ground (GND) unless otherwise stated

DC Electrical Characteristics - Current Consumption

	Characteristics	Sym.	Min.	Typ.	Max.	Units	Notes
1	Supply current LVDS drivers - loaded (all outputs are active)	I_{dd_load}		106		mA	

DC Electrical Characteristics - Inputs and outputs - for 2.5/3.3 V supply

	Characteristics	Sym.	Min.	Typ.	Max.	Units	Notes
1	Differential input common mode	V_{ICM}	1.1		1.6	V	for 2.5 V
2	Differential input common mode	V_{ICM}	1.1		2.0	V	for 3.3 V
3	Differential input voltage difference	V_{ID}	0.25		1	V	
4	Differential input resistance	V_{IR}	80	100	120	ohm	
5	LVDS output differential voltage*	V_{OD}	0.25	0.30	0.40	V	
6	LVDS Common Mode voltage	V_{CM}	1.1	1.25	1.375	V	

* The VOD parameter was measured between 125 and 750 MHz



Figure 19 - Differential Voltage Parameter

AC Electrical Characteristics* - Inputs and Outputs (see Figure 20) - for 2.5/3.3 V supply.

	Characteristics	Sym.	Min.	Typ.	Max.	Units	Notes
1	Maximum Operating Frequency	1/t _p			750	MHz	
2	input to output clock propagation delay	t _{pd}	0	1	2	ns	
3	output to output skew	t _{out2out}		80	150	ps	
4	part to part output skew	t _{part2part}		120	300	ps	
5	Output clock Duty Cycle degradation	t _{PWH} / t _{PWL}	-5	0	5	Percent	
6	LVDS Output slew rate	r _{SL}	0.55			V/ns	

* Supply voltage and operating temperature are as per Recommended Operating Conditions

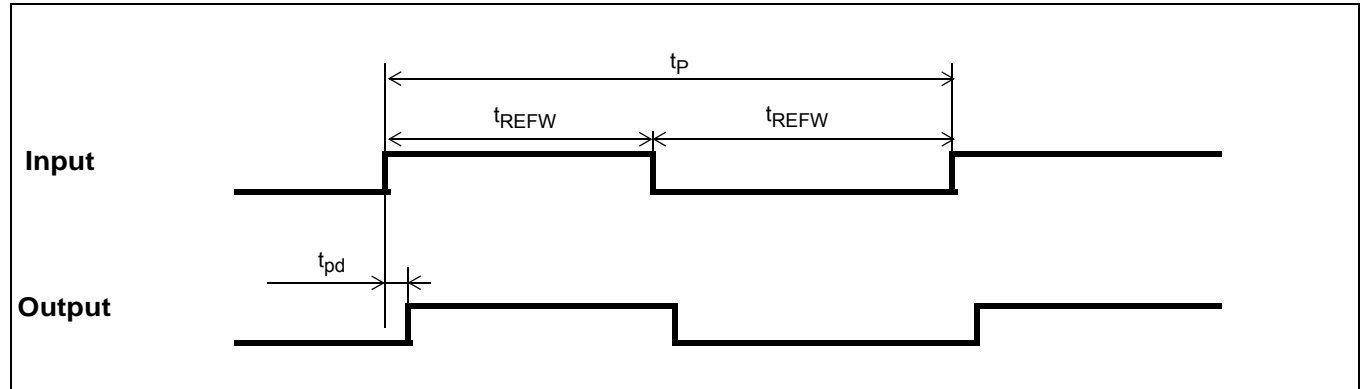

Figure 20 - Input To Output Timing

5.0 Performance Characterization

Additive Jitter at 2.5 V*

	Output Frequency (MHz)	Jitter Measurement Filter	Typical RMS (fs)	Notes
1	125	12 kHz - 20 MHz	148	
2	212.5	12 kHz - 20 MHz	138	
3	311.04	12 kHz - 20 MHz	121	
4	425	12 kHz - 20 MHz	115	
5	500	12 kHz - 20 MHz	107	
6	622.08	12 kHz - 20 MHz	107	
7	750	12 kHz - 20 MHz	105	

*The values in this table were taken with a slew rate of approximately 0.8 V/ns.

Additive Jitter at 3.3 V*

	Output Frequency (MHz)	Jitter Measurement Filter	Typical RMS (fs)	Notes
1	125	12 kHz - 20 MHz	150	
2	212.5	12 kHz - 20 MHz	138	
3	311.04	12 kHz - 20 MHz	120	
4	425	12 kHz - 20 MHz	115	
5	500	12 kHz - 20 MHz	107	
6	622.08	12 kHz - 20 MHz	106	
7	750	12 kHz - 20 MHz	104	

*The values in this table were taken with a slew rate of approximately 0.8 V/ns.

Additive jitter from a power supply tone*

Carrier frequency	Parameter	Typical	Units	Notes
125	25 mV at 100 kHz	24	fs RMS	
750	25 mV at 100 kHz	23	fs RMS	

* The values in this table are the additive periodic jitter caused by an interfering tone typically caused by a switching power supply. For this test, measurements were taken over the full temperature and voltage range for $V_{DD} = 3.3$ V. The magnitude of the interfering tone is measured at the DUT.

6.0 Typical Behavior

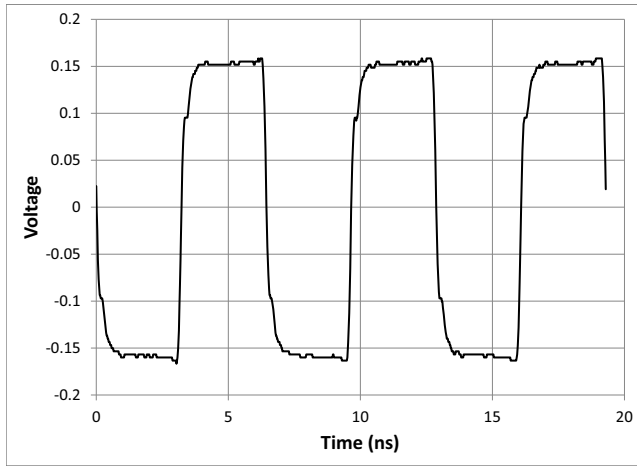

Typical Waveform at 155.52 MHz

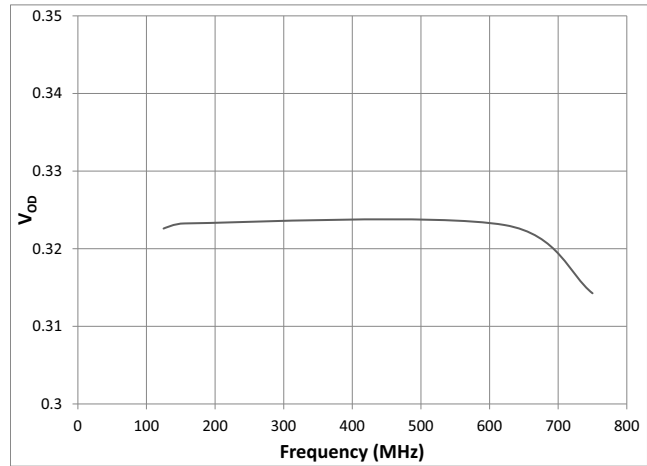

V_{OD} vs Frequency

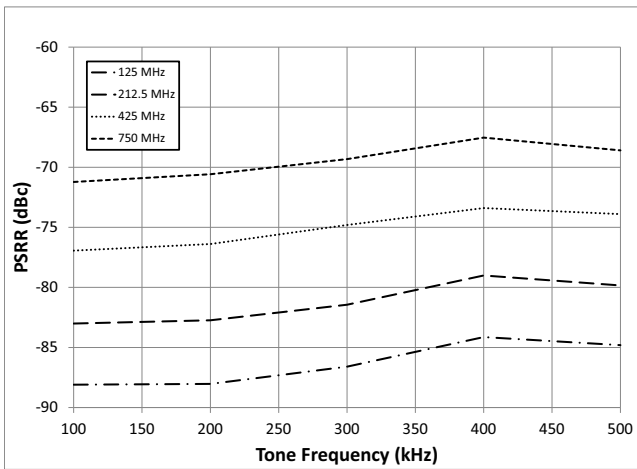

Power Supply Tone Frequency versus PSRR

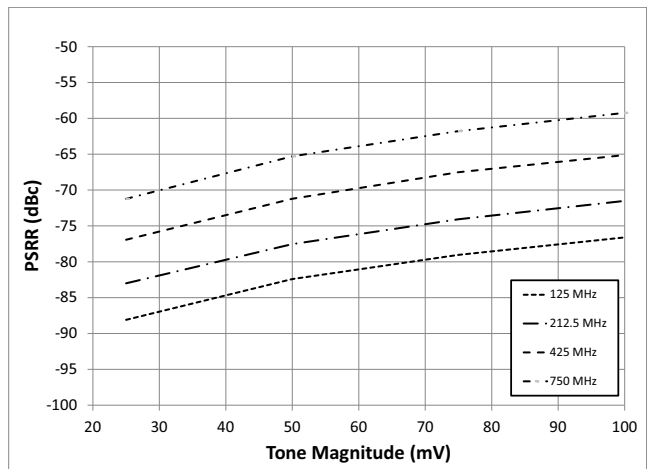

Power Supply Tone Magnitude versus PSRR

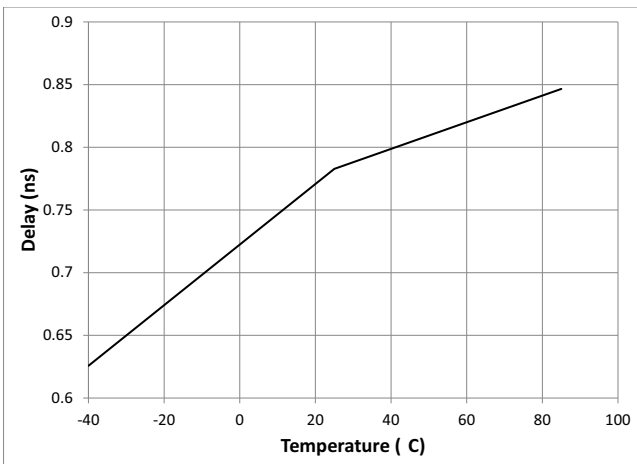

Propagation Delay versus Temperature

Note: This is for a single device. For more details, see the characterization section.

7.0 Package Characteristics

Thermal Data

Parameter	Symbol	Test Condition	Value	Unit
Junction to Ambient Thermal Resistance	Θ_{JA}	Still Air	37.4	$^{\circ}\text{C}/\text{W}$
		1 m/s	33.1	
		2 m/s	31.5	
Junction to Case Thermal Resistance	Θ_{JC}		24.4	$^{\circ}\text{C}/\text{W}$
Junction to Board Thermal Resistance	Θ_{JB}		19.5	$^{\circ}\text{C}/\text{W}$
Maximum Junction Temperature*	T_{jmax}		125	$^{\circ}\text{C}$
Maximum Ambient Temperature	T_A		85	$^{\circ}\text{C}$

8.0 Mechanical Drawing

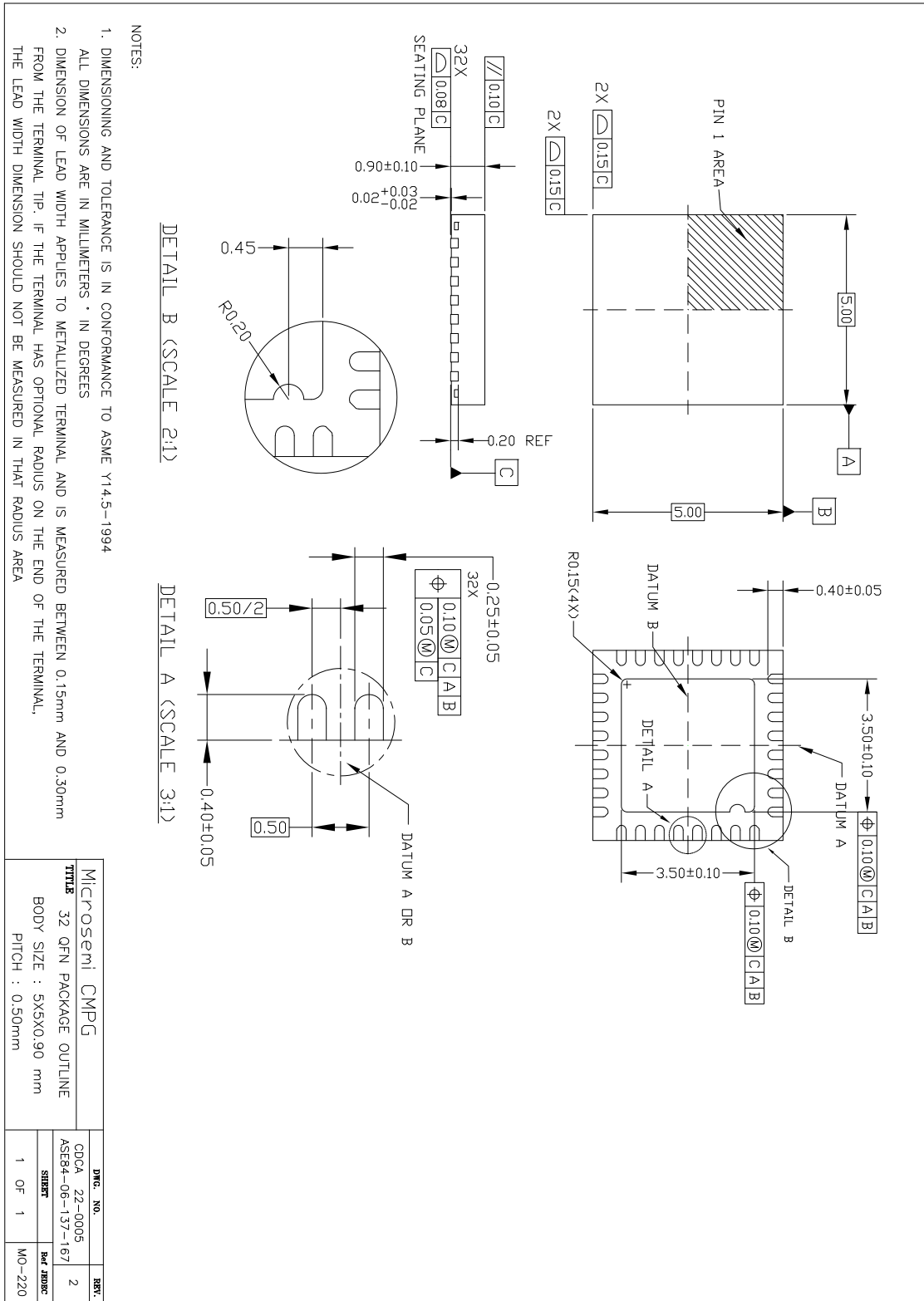



**For more information about all Microsemi products visit our Web Site at
www.microsemi.com**

Information relating to products and services furnished herein by Microsemi Corporation or its subsidiaries (collectively "Microsemi") is believed to be reliable. However, Microsemi assumes no liability for errors that may appear in this publication, or for liability otherwise arising from the application or use of any such information, product or service or for any infringement of patents or other intellectual property rights owned by third parties which may result from such application or use. Neither the supply of such information or purchase of product or service conveys any license, either express or implied, under patents or other intellectual property rights owned by Microsemi or licensed from third parties by Microsemi, whatsoever. Purchasers of products are also hereby notified that the use of product in certain ways or in combination with Microsemi, or non-Microsemi furnished goods or services may infringe patents or other intellectual property rights owned by Microsemi.

This publication is issued to provide information only and (unless agreed by Microsemi in writing) may not be used, applied or reproduced for any purpose nor form part of any order or contract nor to be regarded as a representation relating to the products or services concerned. The products, their specifications, services and other information appearing in this publication are subject to change by Microsemi without notice. No warranty or guarantee express or implied is made regarding the capability, performance or suitability of any product or service. Information concerning possible methods of use is provided as a guide only and does not constitute any guarantee that such methods of use will be satisfactory in a specific piece of equipment. It is the user's responsibility to fully determine the performance and suitability of any equipment using such information and to ensure that any publication or data used is up to date and has not been superseded. Manufacturing does not necessarily include testing of all functions or parameters. These products are not suitable for use in any medical **and other** products whose failure to perform may result in significant injury or death to the user. All products and materials are sold and services provided subject to Microsemi's conditions of sale which are available on request.

Purchase of Microsemi's I2C components conveys a license under the Philips I2C Patent rights to use these components in an I2C System, provided that the system conforms to the I2C Standard Specification as defined by Philips.

Microsemi, ZL, and combinations thereof, VoiceEdge, VoicePort, SLAC, ISLIC, ISLAC and VoicePath are trademarks of Microsemi Corporation.

TECHNICAL DOCUMENTATION - NOT FOR RESALE

Looking for pricing, stock, or lifecycle information?

Click below to explore more details on WIN SOURCE:

-  [View ZL40218LDG1 on WIN SOURCE](#)
-  [Microchip Technology Information](#)

Optimize Your Supply Chain with WIN SOURCE Solutions

-  Global Sourcing Solution
-  Obsolete Management
-  Cost Control Management
-  Shortage Management
-  Alternative Solution
-  Excess Inventory Management