



**THE DATASHEET OF  
2305NZ-1HDCGI**



FEATURES:

- One input to five output buffer/driver
- Low power consumption for mobile applications: less than 32mA at 66.6MHz with unloaded outputs
- 8.7ns max input-output delay
- Buffers all frequencies from DC to 133.33MHz
- Output-output skew < 250ps
- 3.3V operation
- High drive capability
- Available in SOIC package

DESCRIPTION:

The IDT2305NZ is a low-cost buffer designed to distribute high-speed clocks in mobile PC systems and desktop PC systems. The IDT2305NZ operates at 3.3V with five outputs that can run up to 133.33MHz

The IDT2305NZ is an 8-pin version of the IDT2309NZ. It is designed for low EMI and power optimization and consumes less than 32mA at 66.6MHz, making it ideal for the low power requirements of mobile systems.

FUNCTIONAL BLOCK DIAGRAM

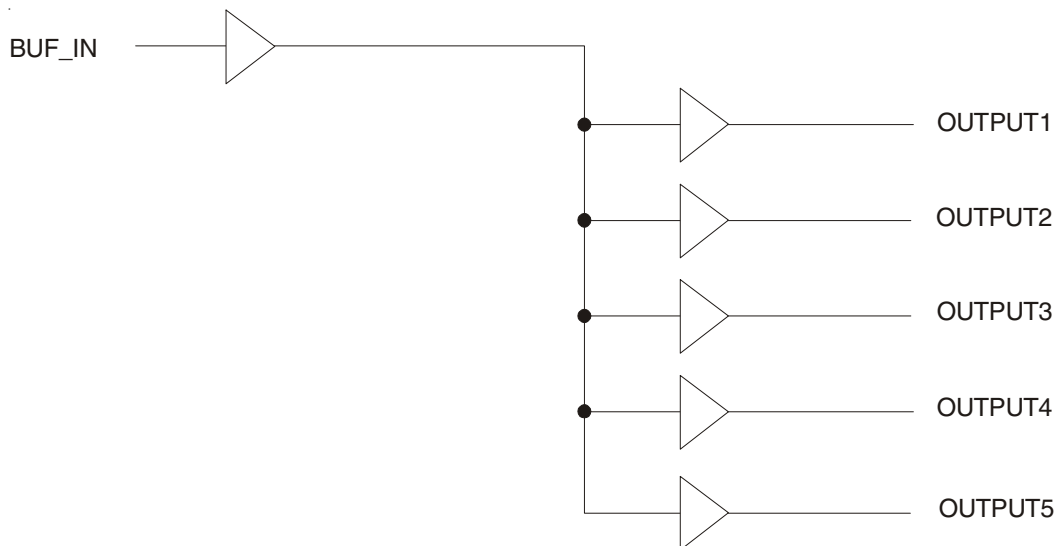

## PIN CONFIGURATION

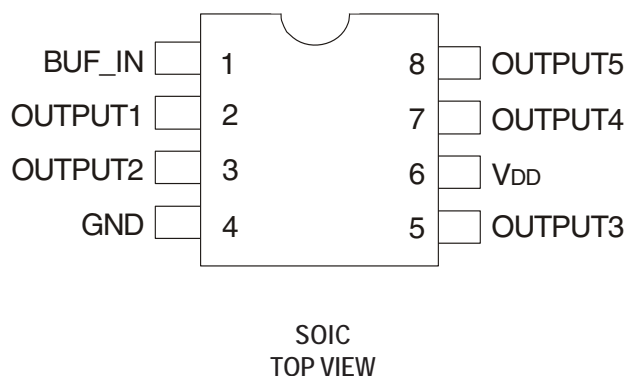

## ABSOLUTE MAXIMUM RATINGS<sup>(1)</sup>

Symbol	Rating	Max.	Unit
V <sub>DD</sub>	Supply Voltage Range	-0.5 to +4.6	V
V <sub>I</sub> <sup>(2)</sup>	Input Voltage Range (REF)	-0.5 to +5.5	V
V <sub>I</sub>	Input Voltage Range (except REF)	-0.5 to V <sub>DD</sub> +0.5	V
I <sub>IK</sub> (V <sub>I</sub> < 0)	Input Clamp Current	-50	mA
I <sub>O</sub> (V <sub>O</sub> = 0 to V <sub>DD</sub> )	Continuous Output Current	±50	mA
V <sub>DD</sub> or GND	Continuous Current	±100	mA
T <sub>A</sub> = 55°C (in still air) <sup>(3)</sup>	Maximum Power Dissipation	0.7	W
T <sub>STG</sub>	Storage Temperature Range	-65 to +150	°C
Operating Temperature	Commercial Temperature Range	0 to +70	°C
Operating Temperature	Industrial Temperature Range	-40 to +85	°C

### NOTES:

1. Stresses greater than those listed under ABSOLUTE MAXIMUM RATINGS may cause permanent damage to the device. This is a stress rating only and functional operation of the device at these or any other conditions above those indicated in the operational sections of this specification is not implied. Exposure to absolute maximum rating conditions for extended periods may affect reliability.
2. The input and output negative-voltage ratings may be exceeded if the input and output clamp-current ratings are observed.
3. The maximum package power dissipation is calculated using a junction temperature of 150°C and a board trace length of 750 mils.

## PIN DESCRIPTION

Pin Name	Pin Number	Functional Description
V <sub>DD</sub>	6	3.3V Digital Voltage Supply
GND	4	Ground
BUF_IN	1	Input clock
OUTPUT <sub>[1:5]</sub>	2, 3, 6, 7, 10	Outputs

## OPERATING CONDITIONS - COMMERCIAL

Symbol	Parameter	Min.	Max.	Unit
V <sub>DD</sub>	Supply Voltage	3	3.6	V
T <sub>A</sub>	Operating Temperature (Ambient Temperature)	0	70	°C
C <sub>L</sub>	Load Capacitance, F <sub>OUT</sub> < 100MHz	—	30	pF
	Load Capacitance 100MHz < F <sub>OUT</sub> < 133.33MHz	—	15	
C <sub>IN</sub>	Input Capacitance	—	7	pF
BUF_IN, OUTPUT <sub>[1:5]</sub>	Operating Frequency	DC	133.33	MHz

## OPERATING CONDITIONS - INDUSTRIAL

Symbol	Parameter	Min.	Max.	Unit
V <sub>DD</sub>	Supply Voltage	3	3.6	V
T <sub>A</sub>	Operating Temperature (Ambient Temperature)	-40	+85	°C
C <sub>L</sub>	Load Capacitance, F <sub>OUT</sub> < 100MHz	—	30	pF
	Load Capacitance 100MHz < F <sub>OUT</sub> < 133.33MHz	—	15	
C <sub>IN</sub>	Input Capacitance	—	7	pF
BUF_IN, OUTPUT <sub>[1:5]</sub>	Operating Frequency	DC	133.33	MHz

## DC ELECTRICAL CHARACTERISTICS - COMMERCIAL

Symbol	Parameter	Conditions	Min.	Max.	Unit
V <sub>IL</sub>	Input LOW Voltage <sup>(1)</sup>		—	0.8	V
V <sub>IH</sub>	Input HIGH Voltage <sup>(1)</sup>		2	—	V
I <sub>IL</sub>	Input LOW Current	V <sub>IN</sub> = 0V	—	50	μA
I <sub>IH</sub>	Input HIGH Current	V <sub>IN</sub> = V <sub>DD</sub>	—	100	μA
V <sub>OL</sub>	Output LOW Voltage <sup>(2)</sup>	I <sub>OL</sub> = 12mA	—	0.4	V
V <sub>OH</sub>	Output HIGH Voltage <sup>(2)</sup>	I <sub>OH</sub> = -12mA	2.4	—	V
I <sub>DD</sub>	Supply Current	Unloaded Outputs at 66.66MHz	—	32	mA

NOTES:

1. BUF\_IN input has a threshold voltage of V<sub>DD</sub>/2.
2. Parameter is guaranteed by design but not production tested.

## DC ELECTRICAL CHARACTERISTICS - INDUSTRIAL

Symbol	Parameter	Conditions	Min.	Max.	Unit
V <sub>IL</sub>	Input LOW Voltage <sup>(1)</sup>		—	0.8	V
V <sub>IH</sub>	Input HIGH Voltage <sup>(1)</sup>		2	—	V
I <sub>IL</sub>	Input LOW Current	V <sub>IN</sub> = 0V	—	50	μA
I <sub>IH</sub>	Input HIGH Current	V <sub>IN</sub> = V <sub>DD</sub>	—	100	μA
V <sub>OL</sub>	Output LOW Voltage <sup>(2)</sup>	I <sub>OL</sub> = 12mA	—	0.4	V
V <sub>OH</sub>	Output HIGH Voltage <sup>(2)</sup>	I <sub>OH</sub> = -12mA	2.4	—	V
I <sub>DD</sub>	Supply Current	Unloaded Outputs at 66.66MHz	—	35	mA

NOTES:

1. BUF\_IN input has a threshold voltage of V<sub>DD</sub>/2.
2. Parameter is guaranteed by design but not production tested.

## SWITCHING CHARACTERISTICS - COMMERCIAL<sup>(1)</sup>

Symbol	Parameter <sup>(2)</sup>	Conditions	Min.	Typ.	Max.	Unit
t <sub>r</sub>	Rise Time	Measured between 0.8V and 2V	—	—	1.5	ns
t <sub>f</sub>	Fall Time	Measured between 0.8V and 2V	—	—	1.5	ns
t <sub>s</sub>	Output to Output Skew	All outputs equally loaded	—	—	250	ps
t <sub>p</sub>	Propagation Delay, BUF_IN Rising Edge to OUTPUT Rising Edge	Measured at V <sub>DD</sub> /2	1	5	8.7	ns
DC	Duty Cycle	Measured at V <sub>DD</sub> /2	45	—	55	%

NOTES:

1. All parameters specified with loaded outputs.
2. Parameter is guaranteed by design but not production tested.

## SWITCHING CHARACTERISTICS - INDUSTRIAL <sup>(1)</sup>

Symbol	Parameter <sup>(2)</sup>	Conditions	Min.	Typ.	Max.	Unit
$t_3$	Rise Time	Measured between 0.8V and 2V	—	—	1.5	ns
$t_4$	Fall Time	Measured between 0.8V and 2V	—	—	1.5	ns
$t_5$	Output to Output Skew	All outputs equally loaded	—	—	250	ps
$t_6$	Propagation Delay, BUF_IN Rising Edge to OUTPUT Rising Edge	Measured at $V_{DD}/2$	1	5	8.7	ns
DC	Duty Cycle	Measured at $V_{DD}/2$	45	—	55	%

NOTES:

1. All parameters specified with loaded outputs.
2. Parameter is guaranteed by design but not production tested.

## SWITCHING WAVEFORMS

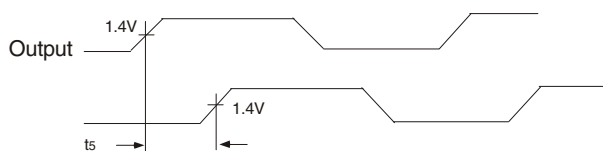

*Output to Output Skew*

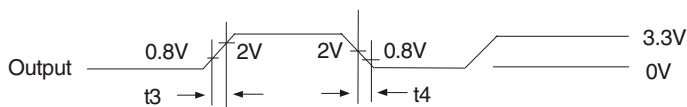

*All Outputs Rise/Fall Time*

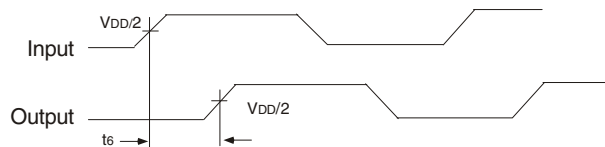

*Input to Output Propagation Delay*

## TEST CIRCUIT

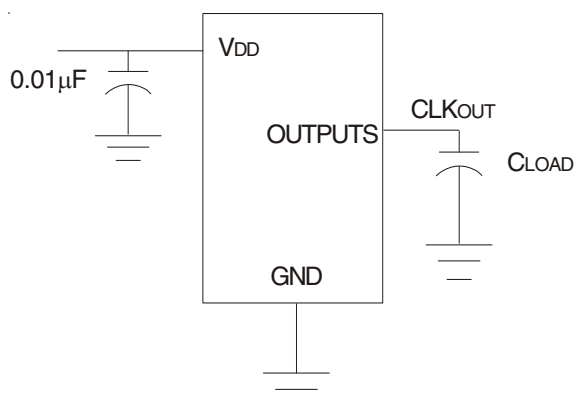

PACKAGE OUTLINE AND DIMENSIONS

<p>REVISIONS</p> <table border="1" style="width: 100%; border-collapse: collapse;"> <tr> <th>REV</th> <th>DESCRIPTION</th> <th>DATE</th> <th>APPROVED</th> </tr> <tr> <td>00</td> <td>INITIAL RELEASE</td> <td>2/24/16</td> <td>JH</td> </tr> </table>	REV	DESCRIPTION	DATE	APPROVED	00	INITIAL RELEASE	2/24/16	JH	<p style="text-align: center;">DIMENSIONS IN MILLIMETERS</p> <div style="display: flex; justify-content: space-around;"> <div style="text-align: center;"> <p>PIN 1 ID</p> </div> <div style="text-align: center;"> <p>VIEW X k X 45°</p> </div> </div> <div style="display: flex; justify-content: space-around; margin-top: 20px;"> <table border="1" style="width: 45%; border-collapse: collapse;"> <caption>DIMENSIONS OF SUB-GROUP B1</caption> <tr><td>A max</td><td>1.95</td></tr> <tr><td>bp min</td><td>0.35</td></tr> <tr><td>bp max</td><td>0.49</td></tr> <tr><td>e nom</td><td>1.27</td></tr> <tr><td>He min</td><td>5.80</td></tr> <tr><td>He max</td><td>6.30</td></tr> <tr><td>Lp min</td><td>0.40</td></tr> <tr><td>Z max</td><td>0.635</td></tr> </table> <table border="1" style="width: 45%; border-collapse: collapse;"> <caption>DIMENSIONS OF SUB-GROUP C1</caption> <tr><td>A min</td><td>1.55</td></tr> <tr><td>A1 min</td><td>0.10</td></tr> <tr><td>A1 max</td><td>0.30</td></tr> <tr><td>A2 min</td><td>1.40</td></tr> <tr><td>A2 max</td><td>1.80</td></tr> <tr><td>c min</td><td>0.15</td></tr> <tr><td>c max</td><td>0.25</td></tr> <tr><td>D min*</td><td>4.80</td></tr> <tr><td>D max*</td><td>5.00</td></tr> <tr><td>E min*</td><td>3.80</td></tr> <tr><td>E max*</td><td>4.00</td></tr> <tr><td>k min</td><td>0.33</td></tr> <tr><td>theta max</td><td>0°</td></tr> <tr><td>theta max</td><td>8°</td></tr> </table> </div> <div style="margin-top: 20px;"> <p>2. WEIGHT ≤ 0.3 g</p> <p>3. BODY MATERIAL LOW STRESS EPOXY</p> <p>4. LEAD MATERIAL FeNi-ALLOY or Cu-ALLOY</p> <p>5. LEAD FINISH SOLDER PLATING</p> <p>6. LEAD FORM Z-BENDS</p> </div> <div style="margin-top: 20px;"> <p>* WITHOUT MOLD FLASH</p> </div>	A max	1.95	bp min	0.35	bp max	0.49	e nom	1.27	He min	5.80	He max	6.30	Lp min	0.40	Z max	0.635	A min	1.55	A1 min	0.10	A1 max	0.30	A2 min	1.40	A2 max	1.80	c min	0.15	c max	0.25	D min*	4.80	D max*	5.00	E min*	3.80	E max*	4.00	k min	0.33	theta max	0°	theta max	8°
REV	DESCRIPTION	DATE	APPROVED																																																		
00	INITIAL RELEASE	2/24/16	JH																																																		
A max	1.95																																																				
bp min	0.35																																																				
bp max	0.49																																																				
e nom	1.27																																																				
He min	5.80																																																				
He max	6.30																																																				
Lp min	0.40																																																				
Z max	0.635																																																				
A min	1.55																																																				
A1 min	0.10																																																				
A1 max	0.30																																																				
A2 min	1.40																																																				
A2 max	1.80																																																				
c min	0.15																																																				
c max	0.25																																																				
D min*	4.80																																																				
D max*	5.00																																																				
E min*	3.80																																																				
E max*	4.00																																																				
k min	0.33																																																				
theta max	0°																																																				
theta max	8°																																																				

6001 Silver Creek Valley Rd  
San Jose, CA 95138  
PHONE (408) 244-0000  
FAX (408) 244-0072

www.IDT.com

TITLE DCSB PACKAGE OUTLINE  
150 mil SOP

APPROVALS	DATE	DRWING NO.	REV
DESIGN	DATE	PSC-4068-03	00

DO NOT SCALE DRAWING SHEET 1 OF 1

## ORDERING INFORMATION

Part / Order Number	Shipping Packaging	Package	Temperature
2305NZ-1HDCG	Tubes	8-pin SOIC	0 to +70°
2305NZ-1HDCG8	Tape and Reel	8-pin SOIC	0 to +70°
2305NZ-1HDCGI	Tubes	8-pin SOIC	-40 to +85°
2305NZ-1HDCGI8	Tape and Reel	8-pin SOIC	-40 to +85°

"G" after the two-letter package code denotes Pb-free configuration, RoHS compliant

## IMPORTANT NOTICE AND DISCLAIMER

RENESAS ELECTRONICS CORPORATION AND ITS SUBSIDIARIES (“RENESAS”) PROVIDES TECHNICAL SPECIFICATIONS AND RELIABILITY DATA (INCLUDING DATASHEETS), DESIGN RESOURCES (INCLUDING REFERENCE DESIGNS), APPLICATION OR OTHER DESIGN ADVICE, WEB TOOLS, SAFETY INFORMATION, AND OTHER RESOURCES “AS IS” AND WITH ALL FAULTS, AND DISCLAIMS ALL WARRANTIES, EXPRESS OR IMPLIED, INCLUDING, WITHOUT LIMITATION, ANY IMPLIED WARRANTIES OF MERCHANTABILITY, FITNESS FOR A PARTICULAR PURPOSE, OR NON-INFRINGEMENT OF THIRD-PARTY INTELLECTUAL PROPERTY RIGHTS.

These resources are intended for developers who are designing with Renesas products. You are solely responsible for (1) selecting the appropriate products for your application, (2) designing, validating, and testing your application, and (3) ensuring your application meets applicable standards, and any other safety, security, or other requirements. These resources are subject to change without notice. Renesas grants you permission to use these resources only to develop an application that uses Renesas products. Other reproduction or use of these resources is strictly prohibited. No license is granted to any other Renesas intellectual property or to any third-party intellectual property. Renesas disclaims responsibility for, and you will fully indemnify Renesas and its representatives against, any claims, damages, costs, losses, or liabilities arising from your use of these resources. Renesas' products are provided only subject to Renesas' Terms and Conditions of Sale or other applicable terms agreed to in writing. No use of any Renesas resources expands or otherwise alters any applicable warranties or warranty disclaimers for these products.

(Disclaimer Rev.1.01 Jan 2024)

### Corporate Headquarters

TOYOSU FORESIA, 3-2-24 Toyosu,  
Koto-ku, Tokyo 135-0061, Japan  
[www.renesas.com](http://www.renesas.com)

### Trademarks

Renesas and the Renesas logo are trademarks of Renesas Electronics Corporation. All trademarks and registered trademarks are the property of their respective owners.

### Contact Information

For further information on a product, technology, the most up-to-date version of a document, or your nearest sales office, please visit [www.renesas.com/contact-us/](http://www.renesas.com/contact-us/).

## Looking for pricing, stock, or lifecycle information?

Click below to explore more details on WIN SOURCE:

-  [View 2305NZ-1HDCGI on WIN SOURCE](#)
-  [Renesas Electronics America](#) Information

## Optimize Your Supply Chain with WIN SOURCE Solutions

-  Global Sourcing Solution
-  Obsolete Management
-  Cost Control Management
-  Shortage Management
-  Alternative Solution
-  Excess Inventory Management