



**THE DATASHEET OF
8725AM-21LF**





DIFFERENTIAL-TO-HSTL ZERO DELAY CLOCK GENERATOR

ICS8725-21

General Description



The ICS8725-21 is a highly versatile 1:1 Differential-to-HSTL Clock Generator and a member of the HiPerClockS™ family of High Performance Clock Solutions from IDT. The CLK, nCLK pair can accept most standard differential input levels. The

ICS8725-21 has a fully integrated PLL and can be configured as zero delay buffer, multiplier or divider, and has an output frequency range of 31.25MHz to 630MHz. The reference divider, feedback divider and output divider are each programmable, thereby allowing for the following output-to-input frequency ratios: 8:1, 4:1, 2:1, 1:1, 1:2, 1:4, 1:8. The external feedback allows the device to achieve “zero delay” between the input clock and the output clocks. The PLL_SEL pin can be used to bypass the PLL for system test and debug purposes. In bypass mode, the reference clock is routed around the PLL and into the internal output dividers.

Features

- One differential HSTL output pair
One differential feedback output pair
- Differential CLK/nCLK input pair
- CLK/nCLK pair can accept the following differential input levels: LVPECL, LVDS, HSTL, HCSSL, SSTL
- Output frequency range: 31.25MHz to 630MHz
- Input frequency range: 31.25MHz to 630MHz
- VCO range: 250MHz to 630MHz
- External feedback for “zero delay” clock regeneration with configurable frequencies
- Programmable dividers allow for the following output-to-input frequency ratios: 8:1, 4:1, 2:1, 1:1, 1:2, 1:4, 1:8
- Cycle-to-cycle jitter: 35ps (maximum)
- Output skew: 50ps (maximum)
- Static phase offset: 30ps ± 125ps
- 3.3V core, 1.8V output operating supply
- 0°C to 70°C ambient operating temperature
- Available in both standard (RoHS 5) and lead-free (RoHS 6) packages
- Industrial temperature information available upon request

Block Diagram

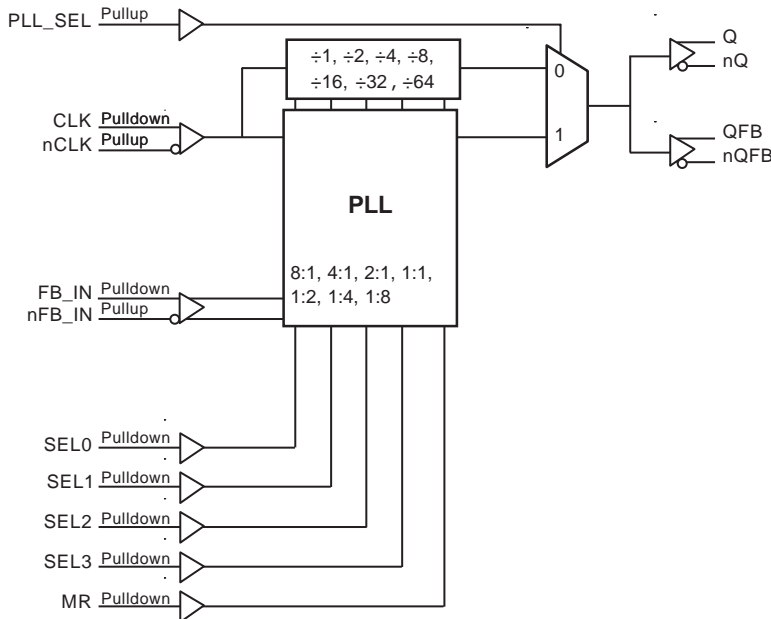

Pin Assignment

CLK	1	20	nc
nCLK	2	19	SEL1
MR	3	18	SEL0
VDD	4	17	VDD
nFB_IN	5	16	PLL_SEL
FB_IN	6	15	VDDA
SEL2	7	14	SEL3
GND	8	13	VDDO
nQFB	9	12	Q
QFB	10	11	nQ

ICS8725-21

20-Lead SOIC

7.5mm x 12.8mm x 2.3mm package body

M Package

Top View

Table 1. Pin Descriptions

Number	Name	Type		Description
1	CLK	Input	Pulldown	Non-inverting differential clock input.
2	nCLK	Input	Pullup	Inverting differential clock input.
3	MR	Input	Pulldown	Active HIGH Master Reset. When logic HIGH, the internal dividers are reset causing the true outputs Q and QFB to go low and the inverted outputs nQ and nQFB to go high. When logic LOW, the internal dividers and the outputs are enabled. LVCMOS / LVTTTL interface levels.
4, 17	V _{DD}	Power		Core supply pins.
5	nFB_IN	Input	Pullup	Inverting differential feedback input to phase detector for regenerating clocks with "Zero Delay." Connect to pin 9.
6	FB_IN	Input	Pulldown	Non-inverted differential feedback input to phase detector for regenerating clocks with "Zero Delay." Connect to pin 10.
7, 14, 18, 19	SEL2, SEL3, SEL0 SEL1	Input	Pulldown	Determines output divider values in Table 3. LVCMOS / LVTTTL interface levels.
8	GND	Power		Power supply ground.
9, 10	nQFB, QFB	Output		Differential feedback output pair. HSTL interface levels.
11, 12	nQ/Q	Output		Differential output pair. HSTL interface levels.
13	V _{DDO}	Power		Output supply pin.
15	V _{DDA}	Power		Analog supply pin.
16	PLL_SEL	Input	Pullup	PLL select. Selects between the PLL and reference clock as the input to the dividers. When LOW, selects reference clock. When HIGH, selects PLL. LVCMOS/LVTTTL interface levels.
20	nc	Unused		No connect.

NOTE: *Pullup and Pulldown* refer to internal input resistors. See Table 2, *Pin Characteristics*, for typical values.

Table 2. Pin Characteristics

Symbol	Parameter	Test Conditions	Minimum	Typical	Maximum	Units
C _{IN}	Input Capacitance			4		pF
R _{PULLUP}	Input Pullup Resistor			51		kΩ
R _{PULLDOWN}	Input Pulldown Resistor			51		kΩ

Function Tables

Table 3A. Control Input Function Table

Inputs					Outputs PLL_SEL = 1 PLL Enable Mode
SEL3	SEL2	SEL1	SEL0	Reference Frequency Range (MHz)*	Q/nQ
0	0	0	0	250 - 630	÷1
0	0	0	1	125 - 315	÷1
0	0	1	0	62.5 - 157.5	÷1
0	0	1	1	31.25 - 78.75	÷1
0	1	0	0	250 - 630	÷2
0	1	0	1	125 - 315	÷2
0	1	1	0	62.5 - 157.5	÷2
0	1	1	1	31.25 - 78.75	÷4
1	0	0	0	125 - 315	÷4
1	0	0	1	250 - 630	÷8
1	0	1	0	125 - 315	x2
1	0	1	1	62.5 - 157.5	x2
1	1	0	0	31.25 - 78.75	x2
1	1	0	1	62.5 - 157.5	x4
1	1	1	0	31.25 - 78.75	x4
1	1	1	1	31.25 - 78.75	x8

*NOTE: VCO frequency range for all configurations above is 250MHz to 630MHz.

Table 3B. PLL Bypass Function Table

Inputs				Outputs PLL_SEL = 0 PLL Bypass Mode
SEL3	SEL2	SEL1	SEL0	Q/nQ, QFB/nQFB
0z	0	0	0	÷4
0	0	0	1	÷4
0	0	1	0	÷4
0	0	1	1	÷8
0	1	0	0	÷8
0	1	0	1	÷8
0	1	1	0	÷16
0	1	1	1	÷16
1	0	0	0	÷32
1	0	0	1	÷64
1	0	1	0	÷2
1	0	1	1	÷2
1	1	0	0	÷4
1	1	0	1	÷1
1	1	1	0	÷2
1	1	1	1	÷1

Absolute Maximum Ratings

NOTE: Stresses beyond those listed under *Absolute Maximum Ratings* may cause permanent damage to the device. These ratings are stress specifications only. Functional operation of product at these conditions or any conditions beyond those listed in the *DC Characteristics* or *AC Characteristics* is not implied. Exposure to absolute maximum rating conditions for extended periods may affect product reliability.

Item	Rating
Supply Voltage, V_{DD}	4.6V
Inputs, V_I	-0.5V to $V_{DD} + 0.5V$
Outputs, V_O	-0.5V to $V_{DDO} + 0.5V$
Package Thermal Impedance, θ_{JA}	46.2°C/W (0 lfpm)
Storage Temperature, T_{STG}	-65°C to 150°C

DC Electrical Characteristics

Table 4A. Power Supply DC Characteristics, $V_{DD} = V_{DDA} = 3.3V \pm 5\%$, $V_{DDO} = 1.8V \pm 0.2V$, $T_A = 0^\circ\text{C}$ to 70°C

Symbol	Parameter	Test Conditions	Minimum	Typical	Maximum	Units
V_{DD}	Core Supply Voltage		3.135	3.3	3.465	V
V_{DDA}	Analog Supply Voltage		3.135	3.3	3.465	V
V_{DDO}	Output Supply Voltage		1.6	1.8	2.0	V
I_{DD}	Power Supply Current				137	mA
I_{DDA}	Analog Supply Current				17	mA
I_{DDO}	Output Supply Current			0		mA

Table 4B. LVCMOS/LVTTL DC Characteristics, $V_{DD} = V_{DDA} = 3.3V \pm 5\%$, $V_{DDO} = 1.8V \pm 0.2V$, $T_A = 0^\circ\text{C}$ to 70°C

Symbol	Parameter	Test Conditions	Minimum	Typical	Maximum	Units
V_{IH}	Input High Voltage		2		$V_{DD} + 0.3$	V
V_{IL}	Input Low Voltage		-0.3		0.8	V
I_{IH}	Input High Current	SEL[0:3], MR	$V_{DD} = V_{IN} = 3.465V$		150	μA
		PLL_SEL	$V_{DD} = V_{IN} = 3.465V$		5	μA
I_{IL}	Input Low Current	SEL[0:3], MR	$V_{DD} = 3.465V, V_{IN} = 0V$	-5		μA
		PLL_SEL	$V_{DD} = 3.465V, V_{IN} = 0V$	-150		μA

Table 4C. Differential DC Characteristics, $V_{DD} = V_{DDA} = 3.3V \pm 5\%$, $V_{DDO} = 1.8V \pm 0.2V$, $T_A = 0^\circ\text{C}$ to 70°C

Symbol	Parameter	Test Conditions	Minimum	Typical	Maximum	Units
I_{IH}	Input High Current	CLK, FB_IN	$V_{DD} = V_{IN} = 3.465V$		150	μA
		nCLK, nFB_IN	$V_{DD} = V_{IN} = 3.465V$		5	μA
I_{IL}	Input Low Current	CLK, FB_IN	$V_{DD} = 3.465V$, $V_{IN} = 0V$	-5		μA
		nCLK, nFB_IN	$V_{DD} = 3.465V$, $V_{IN} = 0V$	-150		μA
V_{PP}	Peak-to-Peak Voltage; NOTE 1		0.15		1.3	V
V_{CMR}	Common Mode Input Voltage; NOTE 1, 2		GND + 0.5		$V_{DD} - 0.85$	V

NOTE 1: V_{IL} should not be less than -0.3V.NOTE 2: Common mode input voltage is defined as V_{IH} .**Table 4D. HSTL DC Characteristics, $V_{DD} = V_{DDA} = 3.3V \pm 5\%$, $V_{DDO} = 1.8V \pm 0.2V$, $T_A = 0^\circ\text{C}$ to 70°C**

Symbol	Parameter	Test Conditions	Minimum	Typical	Maximum	Units
V_{OH}	Output High Voltage; NOTE 1		1.0		1.4	V
V_{OL}	Output Low Voltage; NOTE 1		0		0.4	V
V_{OX}	Output Crossover Voltage; NOTE 2		40		60	%
V_{SWING}	Peak-to-Peak Output Voltage Swing		0.6		1.1	V

NOTE 1: Outputs termination with 50Ω to ground.

NOTE 2: Defined with respect to output voltage swing at a given condition.

Table 5. Input Frequency Characteristics, $V_{DD} = V_{DDA} = 3.3V \pm 5\%$, $V_{DDO} = 1.8V \pm 0.2V$, $T_A = 0^\circ\text{C}$ to 70°C

Symbol	Parameter	Test Conditions	Minimum	Typical	Maximum	Units	
F_{IN}	Input Frequency	CLK, nCLK	PLL_SEL = 1	31.25		630	MHz
			PLL_SEL = 0			630	MHz

AC Electrical Characteristics

Table 6. AC Characteristics, $V_{DD} = V_{DDA} = 3.3V \pm 5\%$, $V_{DDO} = 1.8V \pm 0.2V$, $T_A = 0^\circ\text{C}$ to 70°C

Parameter	Symbol	Test Conditions	Minimum	Typical	Maximum	Units
f_{MAX}	Output Frequency				630	MHz
t_{PD}	Propagation Delay; NOTE 1	PLL_SEL = 0V, $f \leq 700\text{MHz}$	3.2		4.5	ns
$t_{sk}(\emptyset)$	Static Phase Offset; NOTE 2, 5	PLL_SEL = 3.3V	-95	30	155	ps
$t_{sk}(o)$	Output Skew; NOTE 3, 5	PLL_SEL = 0V			50	ps
$f_{jit}(cc)$	Cycle-to-Cycle Jitter; NOTE 5, 6				35	ps
$f_{jit}(\theta)$	Phase Jitter; NOTE 4, 5, 6				± 50	ps
t_L	PLL Lock Time				1	ms
t_R / t_F	Output Rise/Fall Time	20% to 80%	300		700	ps
t_{PW}	Output Pulse Width		$t_{PERIOD}/2 - 85$	$t_{PERIOD}/2$	$t_{PERIOD}/2 + 85$	ps

All parameters measured at f_{MAX} unless noted otherwise.

NOTE 1: Measured from the differential input crossing point to the differential output crossing point.

NOTE 2: Defined as the time difference between the input reference clock and the average feedback input signal, when the PLL is locked and the input reference frequency is stable.

NOTE 3: Defined as skew between outputs at the same supply voltage and with equal load conditions. Measured at the output differential cross points.

NOTE 4: Phase jitter is dependent on the input source used.

NOTE 5: This parameter is defined in accordance with JEDEC Standard 65.

NOTE 6: Characterized at VCO frequency of 622MHz.

Parameter Measurement Information

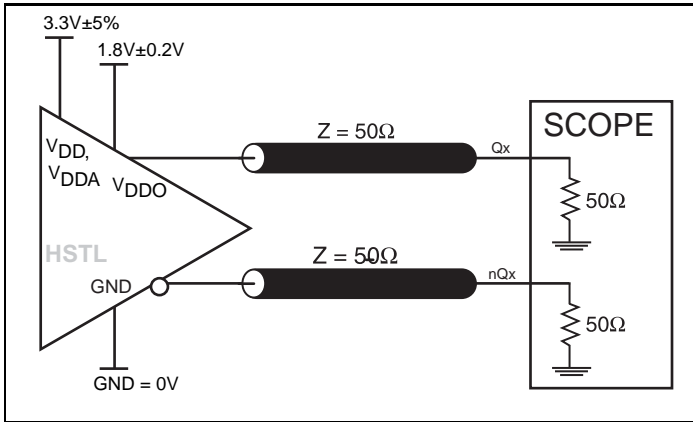

3.3V Core/1.8V Output Load AC Test Circuit

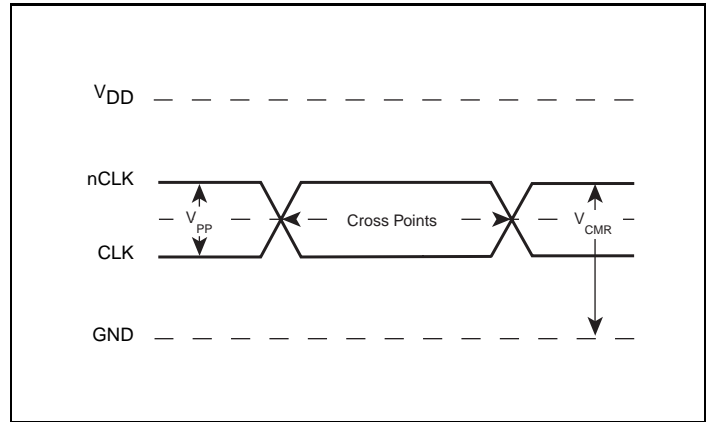

Differential Input Level

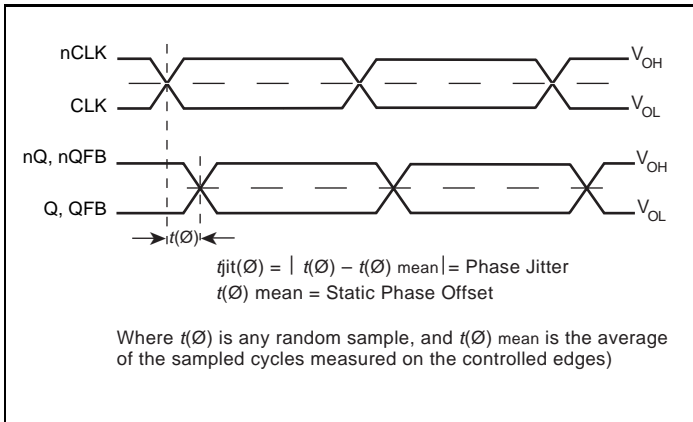

Phase Jitter and Static Phase Offset

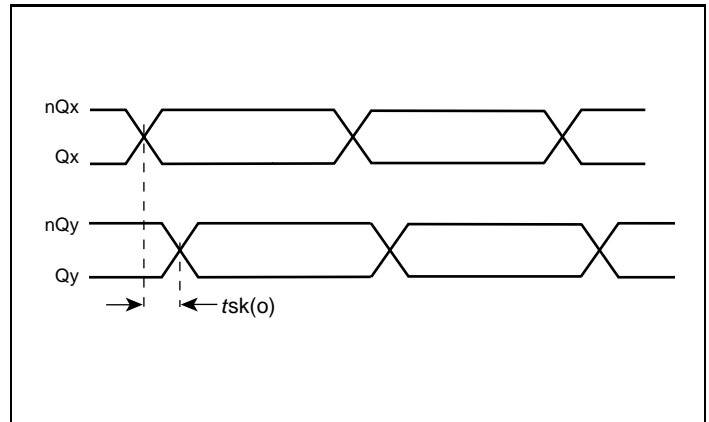

Output Skew

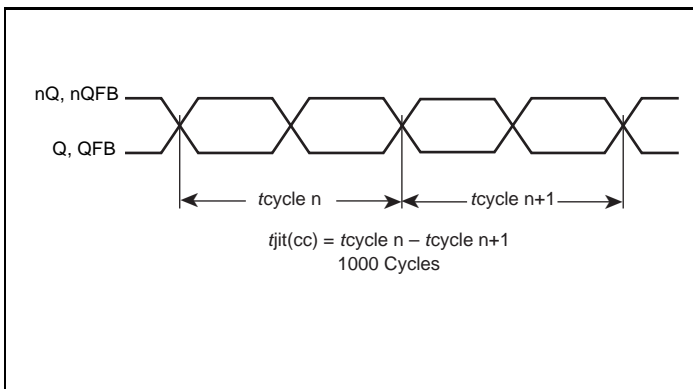

Cycle-to-Cycle Jitter

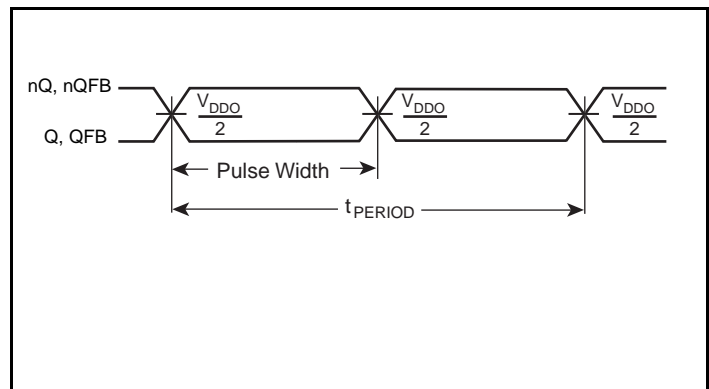

Output Pulse Width

Parameter Measurement Information, continued

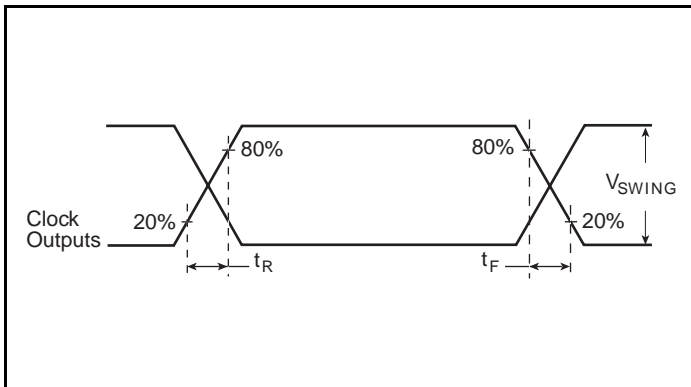

Output Rise/Fall Time

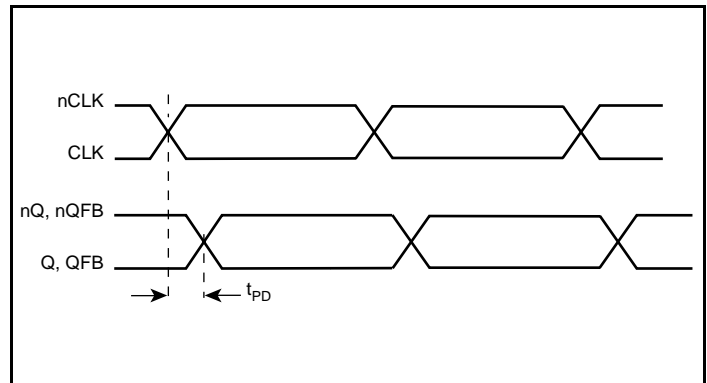

Propagation Delay

Application Information

Power Supply Filtering Technique

To achieve optimum jitter performance, power supply isolation is required. The ICS8725-21 provides separate power supplies to isolate any high switching noise from the outputs to the internal PLL. V_{DD} , V_{DDA} and V_{DDO} should be individually connected to the power supply plane through vias, and $0.01\mu\text{F}$ bypass capacitors should be used for each pin. *Figure 1* illustrates this for a generic V_{DD} pin and also shows that V_{DDA} requires that an additional 10Ω resistor along with a $10\mu\text{F}$ bypass capacitor be connected to the V_{DDA} pin. The 10Ω resistor can also be replaced by a ferrite bead.

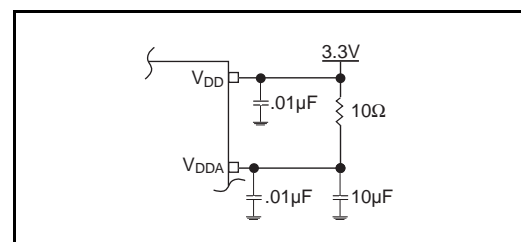

Figure 1. Power Supply Filtering

Recommendations for Unused Input Pins

Inputs:

LVC MOS Control Pins

All control pins have internal pull-ups or pull-downs; additional resistance is not required but can be added for additional protection. A 1k Ω resistor can be used.

Wiring the Differential Input to Accept Single Ended Levels

Figure 2 shows how the differential input can be wired to accept single ended levels. The reference voltage $V_{REF} = V_{DD}/2$ is generated by the bias resistors R1, R2 and C1. This bias circuit should be located as close as possible to the input pin. The ratio of R1 and R2 might need to be adjusted to position the V_{REF} in the center of the input voltage swing. For example, if the input clock swing is only 2.5V and $V_{DD} = 3.3V$, V_{REF} should be 1.25V and $R2/R1 = 0.609$.

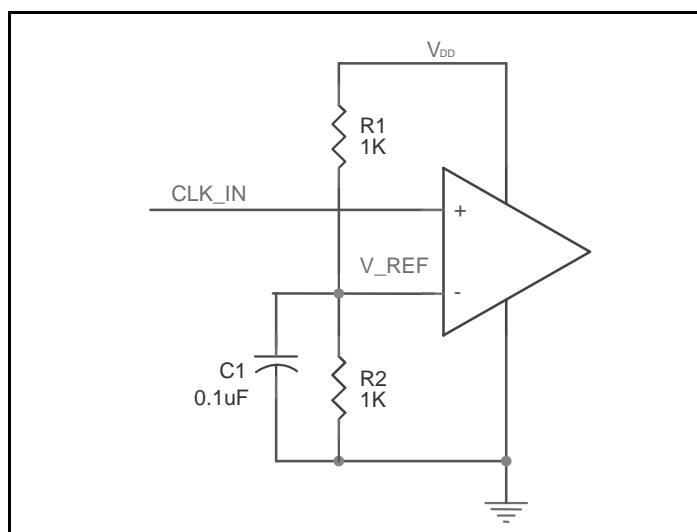

Figure 2. Single-Ended Signal Driving Differential Input

Differential Clock Input Interface

The CLK /nCLK accepts LVDS, LVPECL, LVHSTL, SSTL, HCSL and other differential signals. Both V_{SWING} and V_{OH} must meet the V_{PP} and V_{CMR} input requirements. Figures 3A to 3F show interface examples for the HiPerClockS CLK/nCLK input driven by the most common driver types. The input interfaces suggested here are examples only. Please consult with the vendor of the driver

component to confirm the driver termination requirements. For example, in Figure 3A, the input termination applies for IDT HiPerClockS open emitter LVHSTL drivers. If you are using an LVHSTL driver from another vendor, use their termination recommendation.

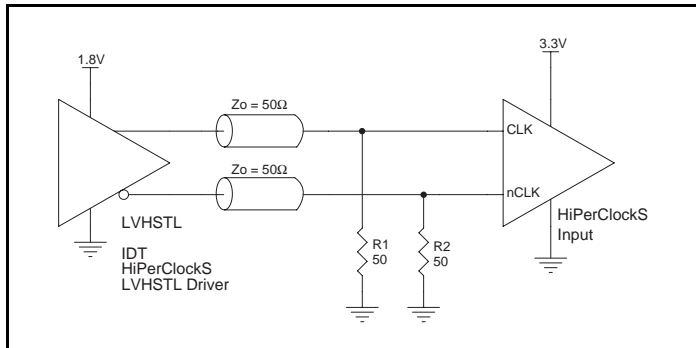

Figure 3A. HiPerClockS CLK/nCLK Input Driven by an IDT Open Emitter HiPerClockS LVHSTL Driver

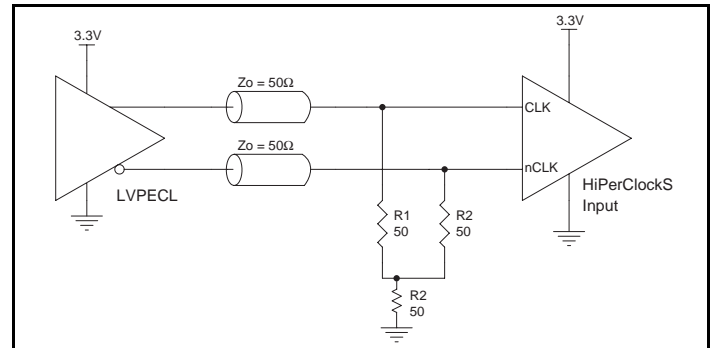

Figure 3B. HiPerClockS CLK/nCLK Input Driven by a 3.3V LVPECL Driver

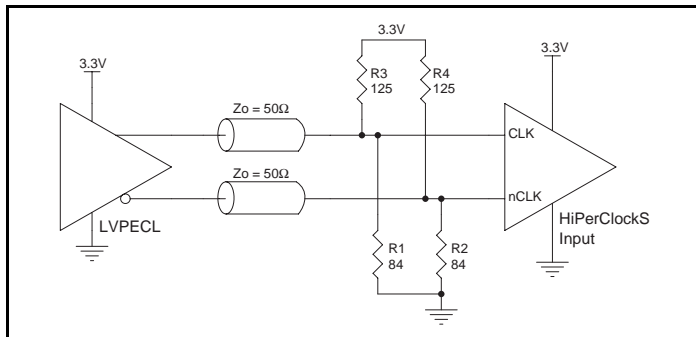

Figure 3C. HiPerClockS CLK/nCLK Input Driven by a 3.3V LVPECL Driver

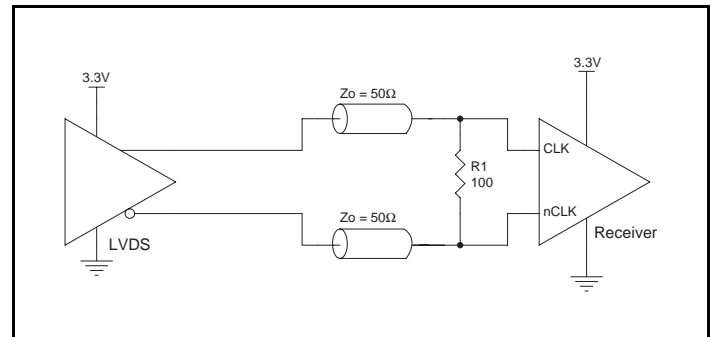

Figure 3D. HiPerClockS CLK/nCLK Input Driven by a 3.3V LVDS Driver

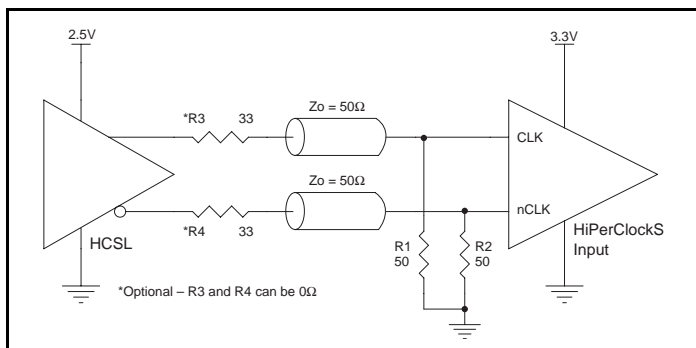

Figure 3E. HiPerClockS CLK/nCLK Input Driven by a 3.3V HCSL Driver

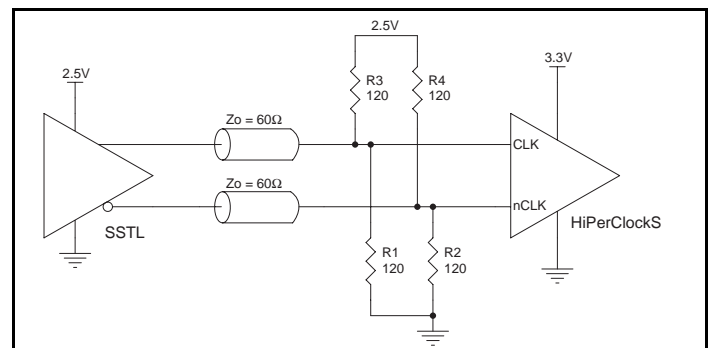

Figure 3F. HiPerClockS CLK/nCLK Input Driven by a 2.5V SSTL Driver

Schematic Example

Figure 4 shows a schematic example of the ICS8725-21. In this example, the input is driven by an HCSL driver. The zero delay buffer is configured to operate at 155.52MHz input and 77.75MHz output. The logic control pins are configured as follows:

SEL[3:0] = 0101

PLL_SEL = 1

For ICS8725-21, the decoupling capacitors should be physically located near the power pin.

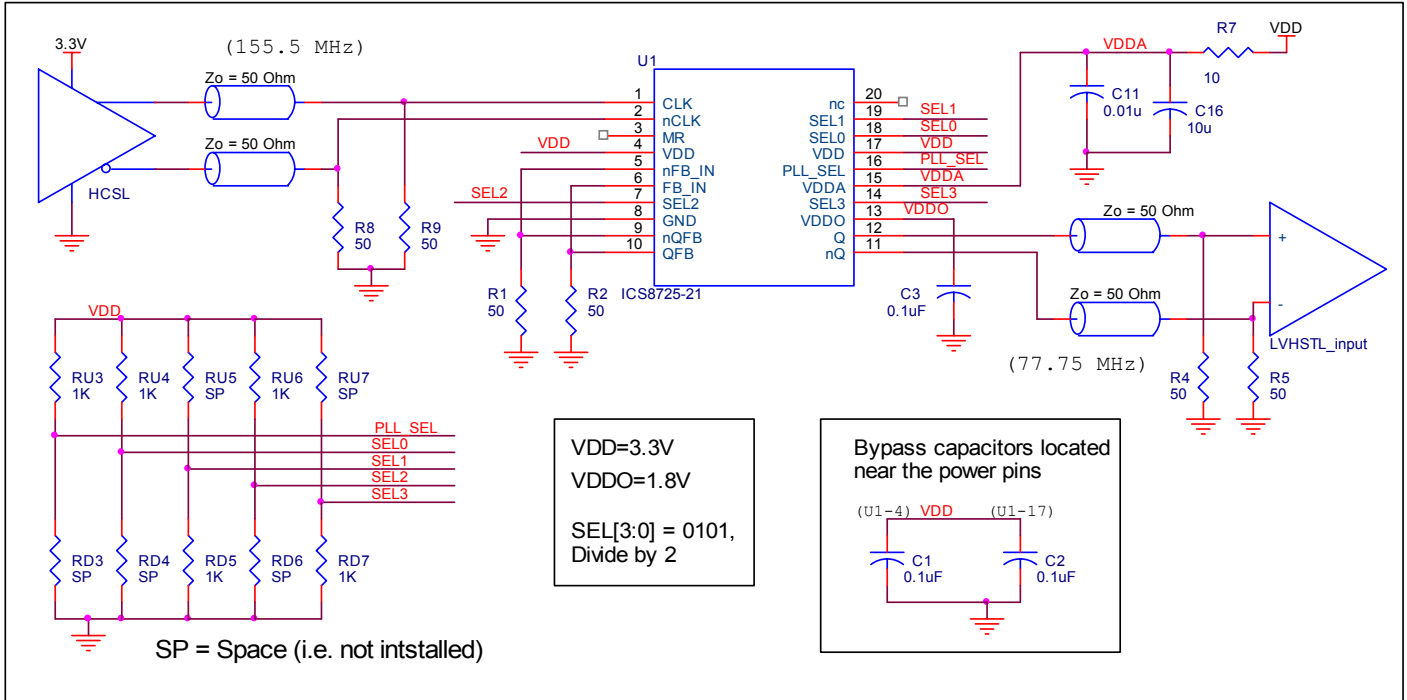

Figure 4. ICS8725-21 HSTL Buffer Schematic Example

Power Considerations

This section provides information on power dissipation and junction temperature for the ICS8725-21. Equations and example calculations are also provided.

1. Power Dissipation.

The total power dissipation for the ICS8725-21 is the sum of the core power plus the power dissipated in the load(s). The following is the power dissipation for $V_{DD} = 3.3V + 5\% = 3.465V$, which gives worst case results.

NOTE: Please refer to Section 3 for details on calculating power dissipated in the load.

- Power (core)_{MAX} = $V_{DD_MAX} * (I_{DD_MAX} + I_{DDA_MAX}) = 3.465V * (137mA + 17mA) = 533.6mW$
- Power (outputs)_{MAX} = **32.8mW/Loaded Output pair**

Total Power_{MAX} (3.465V, with all outputs switching) = $533.6mW + 32.8mW = 566.4mW$

2. Junction Temperature.

Junction temperature, T_j , is the temperature at the junction of the bond wire and bond pad and directly affects the reliability of the device. The maximum recommended junction temperature for HiPerClockS devices is 125°C.

The equation for T_j is as follows: $T_j = \theta_{JA} * Pd_total + T_A$

T_j = Junction Temperature

θ_{JA} = Junction-to-Ambient Thermal Resistance

Pd_total = Total Device Power Dissipation (example calculation is in section 1 above)

T_A = Ambient Temperature

In order to calculate junction temperature, the appropriate junction-to-ambient thermal resistance θ_{JA} must be used. Assuming a moderate air flow of 200 linear feet per minute and a multi-layer board, the appropriate value is 39.7°C/W per Table 7 below.

Therefore, T_j for an ambient temperature of 70°C with all outputs switching is:

$$70^\circ\text{C} + 0.566\text{W} * 39.7^\circ\text{C}/\text{W} = 111^\circ\text{C}. \text{ This is well below the limit of } 125^\circ\text{C}.$$

This calculation is only an example. T_j will obviously vary depending on the number of loaded outputs, supply voltage, air flow and the type of board (single layer or multi-layer).

Table 7. Thermal Resistance θ_{JA} for 20 Lead SOIC, Forced Convection

Linear Feet per Minute	θ_{JA} vs. Air Flow		
	0	200	500
Single-Layer PCB, JEDEC Standard Test Boards	83.2°C/W	65.7°C/W	57.5°C/W
Multi-Layer PCB, JEDEC Standard Test Boards	46.2°C/W	39.7°C/W	36.8°C/W

NOTE: Most modern PCB designs use multi-layered boards. The data in the second row pertains to most designs.

3. Calculations and Equations.

The purpose of this section is to derive the power dissipated into the load.

HSTL output driver circuit and termination are shown in *Figure 5*.

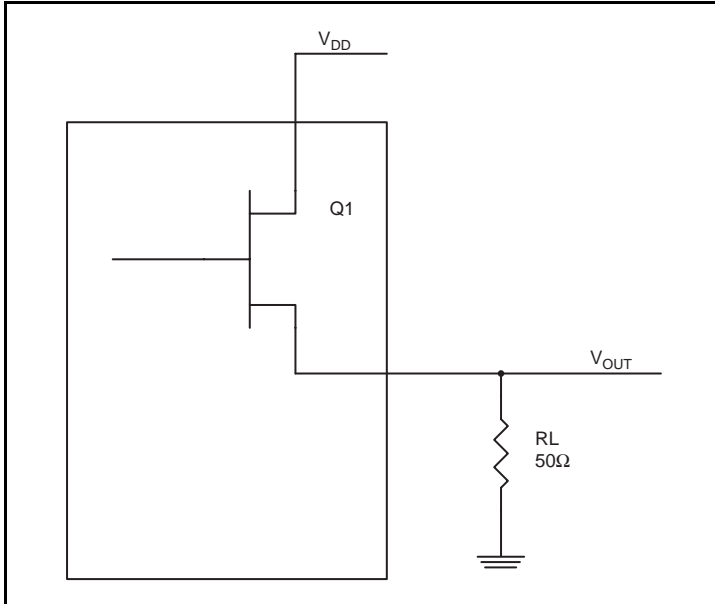

Figure 5. HSTL Driver Circuit and Termination

To calculate worst case power dissipation into the load, use the following equations which assume a 50Ω load.

Pd_H is power dissipation when the output drives high.

Pd_L is the power dissipation when the output drives low.

$$Pd_H = (V_{OH_MAX} / R_L) * (V_{DDO_MAX} - V_{OH_MAX})$$

$$Pd_L = (V_{OL_MAX} / R_L) * (V_{DDO_MAX} - V_{OL_MAX})$$

$$Pd_H = (1.0V / 50\Omega) * (2V - 1.0V) = \mathbf{20mW}$$

$$Pd_L = (0.4V / 50\Omega) * (2V - 0.4V) = \mathbf{12.8mW}$$

$$\text{Total Power Dissipation per output pair} = Pd_H + Pd_L = \mathbf{32.8mW}$$

Reliability Information

Table 8. θ_{JA} vs. Air Flow Table for a 20 Lead TSSOP

θ_{JA} vs. Air Flow			
Linear Feet per Minute	0	200	500
Single-Layer PCB, JEDEC Standard Test Boards	83.2°C/W	65.7°C/W	57.5°C/W
Multi-Layer PCB, JEDEC Standard Test Boards	46.2°C/W	39.7°C/W	36.8°C/W

NOTE: Most modern PCB designs use multi-layered boards. The data in the second row pertains to most designs.

Transistor Count

The transistor count for ICS8725-21 is: 2969

Package Outline and Package Dimensions

Package Outline - M Suffix for 20 Lead SOIC

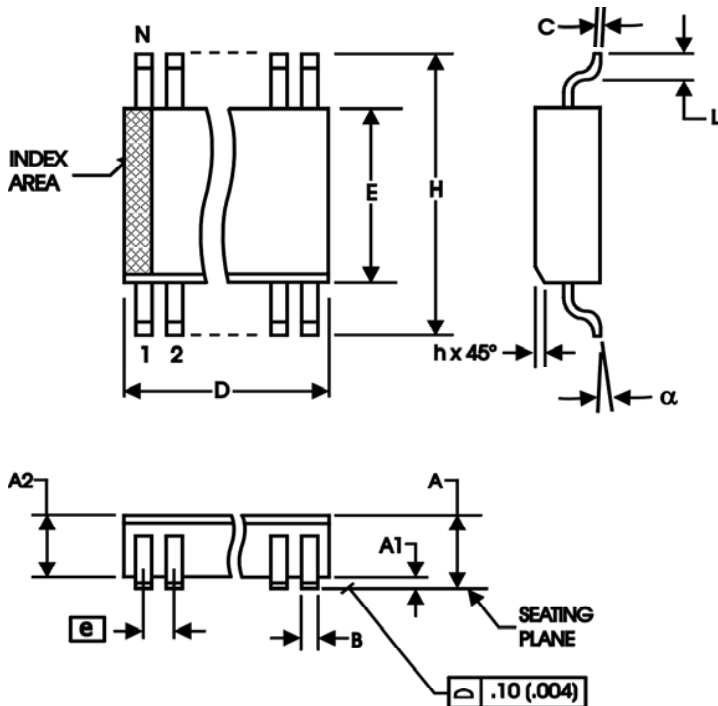

Table 9. Package Dimensions for 20 Lead SOIC

300 Millimeters All Dimensions in Millimeters		
Symbol	Minimum	Maximum
N	20	
A		2.65
A1	0.10	
A2	2.05	2.55
B	0.33	0.51
C	0.18	0.32
D	12.60	13.00
E	7.40	7.60
e	1.27 Basic	
H	10.00	10.65
h	0.25	0.75
L	0.40	1.27
α	0°	8°

Reference Document: JEDEC Publication 95, MS-013, MS-119

Ordering Information

Table 10. Ordering Information

Part/Order Number	Marking	Package	Shipping Packaging	Temperature
ICS8725AM-21	ICS8725AM-21	20 Lead SOIC	Tube	0°C to 70°C
ICS8725AM-21T	ICS8725AM-21	20 Lead SOIC	1000 Tape & Reel	0°C to 70°C
ICS8725AM-21LF	ICS8725AM-21LF	"Lead-Free" 20 Lead SOIC	Tube	0°C to 70°C
ICS8725AM-21LFT	ICS8725AM-21LF	"Lead-Free" 20 Lead SOIC	1000 Tape & Reel	0°C to 70°C

NOTE: Parts that are ordered with an "LF" suffix to the part number are the Pb-Free configuration and are RoHS compliant.

While the information presented herein has been checked for both accuracy and reliability, Integrated Device Technology (IDT) assumes no responsibility for either its use or for the infringement of any patents or other rights of third parties, which would result from its use. No other circuits, patents, or licenses are implied. This product is intended for use in normal commercial applications. Any other applications, such as those requiring extended temperature ranges, high reliability or other extraordinary environmental requirements are not recommended without additional processing by IDT. IDT reserves the right to change any circuitry or specifications without notice. IDT does not authorize or warrant any IDT product for use in life support devices or critical medical instruments.

Revision History Sheet

Rev	Table	Page	Description of Change	Date
A	T10	14	Ordering Information Table - added Lead-Free marking and note.	6/9/05
A	T1	2 8	Pin Descriptions Table - corrected MR description. Added Recommendations for Unused Input and Output Pins.	5/22/06
A		11 12	Updated <i>Differential Clock Input Interface</i> section. Updated <i>Schematic Example</i> section.	2/27/08

Innovate with IDT and accelerate your future networks. Contact:

www.IDT.com

For Sales

800-345-7015
408-284-8200
Fax: 408-284-2775

For Tech Support

netcom@idt.com
480-763-2056

Corporate Headquarters

Integrated Device Technology, Inc.
6024 Silver Creek Valley Road
San Jose, CA 95138
United States
800 345 7015
+408 284 8200 (outside U.S.)

Asia

Integrated Device Technology
IDT (S) Pte. Ltd.
1 Kallang Sector, #07-01/06
Kolam Ayer Industrial Park
Singapore 349276
+65 67443356
Fax: +65 67441764

Japan

NIPPON IDT KK
Sanbancho Tokyu, Bld. 7F,
8-1 Sanbancho
Chiyoda-ku, Tokyo 102-0075
+81 3 3221 9822
Fax: +81 3 3221 9824



Europe

IDT Europe, Limited
321 Kingston Road
Leatherhead, Surrey
KT22 7TU
England
+44 (0) 1372 363 339
Fax: +44 (0) 1372 37885
idteurope@idt.com



Looking for pricing, stock, or lifecycle information?

Click below to explore more details on WIN SOURCE:

-  [View 8725AM-21LF on WIN SOURCE](#)
-  [Renesas Electronics America](#) Information

Optimize Your Supply Chain with WIN SOURCE Solutions

-  Global Sourcing Solution
-  Obsolete Management
-  Cost Control Management
-  Shortage Management
-  Alternative Solution
-  Excess Inventory Management