



**THE DATASHEET OF
HMC8411TCPZ-EP-PT**



FEATURES

- ▶ Low noise figure: 1.7 dB typical
- ▶ Single positive supply (self biased)
- ▶ High gain: 15.5 dB typical
- ▶ High OIP3: 34 dBm typical
- ▶ 6-lead, 2 mm × 2 mm LFCSP

ENHANCED PRODUCT FEATURES

- ▶ Supports defense and aerospace applications (AQEC standard)
Military temperature range (-55°C to +125°C)
- ▶ Controlled manufacturing baseline 1 assembly/test site
- ▶ 1 fabrication site
- ▶ Product change notification
- ▶ Qualification data available on request

APPLICATIONS

- ▶ Test instrumentation
- ▶ Military communications

FUNCTIONAL BLOCK DIAGRAM

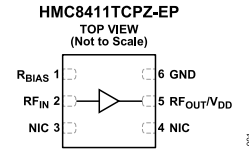

Figure 1.

GENERAL DESCRIPTION

The HMC8411TCPZ-EP is a gallium arsenide (GaAs), monolithic microwave integrated circuit (MMIC), pseudomorphic high electron mobility transistor (pHEMT), low noise wideband amplifier that operates from 0.01 GHz to 10 GHz.

The HMC8411TCPZ-EP provides a typical gain of 15.5 dB, a 1.7 dB typical noise figure, and a typical output third-order intercept (OIP3) of 34 dBm, requiring only 55 mA from a 5 V supply voltage. The saturated output power (P_{SAT}) of 19.5 dBm typical enables the low noise amplifier (LNA) to function as a local oscillator (LO) driver for many of Analog Devices, Inc., balanced, in-phase/quadrature (I/Q), or image rejection mixers.

The HMC8411TCPZ-EP also features inputs and outputs that are internally matched to 50 Ω , making the device ideal for surface-mounted technology (SMT)-based, high capacity microwave radio applications.

The HMC8411TCPZ-EP is housed in a RoHS compliant, 2 mm × 2 mm, 6-lead LFCSP.

Multifunction pin names may be referenced by their relevant function only.

Additional application and technical information can be found in the [HMC8411LP2FE](#) data sheet.

TABLE OF CONTENTS

Features.....	1	Absolute Maximum Ratings.....	5
Enhanced Product Features.....	1	Thermal Resistance.....	5
Applications.....	1	Power Derating Curves.....	5
Functional Block Diagram.....	1	ESD Caution.....	5
General Description.....	1	Pin Configuration and Function Descriptions.....	6
Specifications.....	3	Interface Schematics.....	6
0.01 GHz to 1 GHz Frequency Range.....	3	Typical Performance Characteristics.....	7
1 GHz to 6 GHz Frequency Range.....	3	Outline Dimensions.....	11
6 GHz to 10 GHz Frequency Range.....	3	Ordering Guide.....	11

REVISION HISTORY**10/2021—Rev. 0 to Rev. A**

Changes to Output Power for 1 dB Compression Parameter, Table 3.....	3
Changes to Continuous Power Dissipation, P _{DIS} Parameter, Table 4.....	5
Change to Table 5.....	5
Changes to Figure 2.....	5

7/2019—Revision 0: Initial Version

SPECIFICATIONS

0.01 GHZ TO 1 GHZ FREQUENCY RANGE

$V_{DD} = 5\text{ V}$, supply current (I_{DQ}) = 55 mA, and $T_A = 25^\circ\text{C}$, unless otherwise noted.

Table 1.

Parameter	Symbol	Min	Typ	Max	Unit	Test Conditions/Comments
FREQUENCY RANGE		0.01		1	GHz	
GAIN		12.5	15.5		dB	
Gain Variation over Temperature			0.005		dB/°C	
NOISE FIGURE			1.8		dB	
RETURN LOSS						
Input			22		dB	
Output			17		dB	
OUTPUT						
Output Power for 1 dB Compression	P1dB	17	20		dBm	
Saturated Output Power	P_{SAT}		20.5		dBm	
Output Third-Order Intercept	OIP3		33.5		dBm	Measurement taken at output power (P_{OUT}) per tone = 6 dBm
Output Second-Order Intercept	OIP2		43		dBm	Measurement taken at P_{OUT} per tone = 6 dBm
POWER ADDED EFFICIENCY	PAE		30		%	Measured at P_{SAT}
SUPPLY CURRENT	I_{DQ}		55		mA	
SUPPLY VOLTAGE	V_{DD}	2	5	6	V	

1 GHZ TO 6 GHZ FREQUENCY RANGE

$V_{DD} = 5\text{ V}$, $I_{DQ} = 55\text{ mA}$, and $T_A = 25^\circ\text{C}$, unless otherwise noted.

Table 2.

Parameter	Symbol	Min	Typ	Max	Unit	Test Conditions/Comments
FREQUENCY RANGE		1		6	GHz	
GAIN		12	15		dB	
Gain Variation over Temperature			0.010		dB/°C	
NOISE FIGURE			1.7		dB	
RETURN LOSS						
Input			25		dB	
Output			18		dB	
OUTPUT						
Output Power for 1 dB Compression	P1dB	17	20		dBm	
Saturated Output Power	P_{SAT}		21		dBm	
Output Third-Order Intercept	OIP3		34		dBm	Measurement taken at P_{OUT} per tone = 6 dBm
Output Second-Order Intercept	OIP2		39		dBm	Measurement taken at P_{OUT} per tone = 6 dBm
POWER ADDED EFFICIENCY	PAE		34		%	Measured at P_{SAT}
SUPPLY CURRENT	I_{DQ}		55		mA	
SUPPLY VOLTAGE	V_{DD}	2	5	6	V	

6 GHZ TO 10 GHZ FREQUENCY RANGE

$V_{DD} = 5\text{ V}$, $I_{DQ} = 55\text{ mA}$, and $T_A = 25^\circ\text{C}$, unless otherwise noted.

Table 3.

Parameter	Symbol	Min	Typ	Max	Unit	Test Conditions/Comments
FREQUENCY RANGE		6		10	GHz	
GAIN		11	14		dB	
Gain Variation over Temperature			0.013		dB/°C	

SPECIFICATIONS

Table 3.

Parameter	Symbol	Min	Typ	Max	Unit	Test Conditions/Comments
NOISE FIGURE			2		dB	
RETURN LOSS						
Input			15		dB	
Output			17		dB	
OUTPUT						
Output Power for 1 dB Compression	P1dB	13	16		dBm	
Saturated Output Power	P _{SAT}		19.5		dBm	
Output Third-Order Intercept	OIP3		33		dBm	Measurement taken at P _{OUT} per tone = 6 dBm
Output Second-Order Intercept	OIP2		40		dBm	Measurement taken at P _{OUT} per tone = 6 dBm
POWER ADDED EFFICIENCY	PAE		23		%	Measured at P _{SAT}
SUPPLY CURRENT	I _{DQ}		55		mA	
SUPPLY VOLTAGE	V _{DD}	2	5	6	V	

ABSOLUTE MAXIMUM RATINGS

Table 4.

Parameter ¹	Rating
Drain Bias Voltage (V_{DD})	7 V
Radio Frequency Input (RF_{IN}) Power	20 dBm
Channel Temperature	175°C
Continuous Power Dissipation, P_{DIS} ²	
$T_{CASE} = 85^{\circ}C$	0.78 W
$T_{CASE} = 125^{\circ}C$	0.43 W
Storage Temperature Range	-65°C to +150°C
Operating Temperature Range	-55°C to +125°
Peak Reflow Temperature Moisture Sensitivity Level 1 (MSL1) ³	260°C
Electrostatic Discharge (ESD) Sensitivity Human Body Model (HBM)	500 V, Class 1B passed

¹ When referring to a single function of a multifunction pin in the parameters, only the portion of the pin name that is relevant to the specification is listed. For full pin names of multifunction pins, refer to the [Pin Configuration and Function Descriptions](#) section.

² For maximum power dissipation vs. case temperature, see [Figure 2](#).

³ See the [Ordering Guide](#) section for more information.

Stresses at or above those listed under Absolute Maximum Ratings may cause permanent damage to the product. This is a stress rating only; functional operation of the product at these or any other conditions above those indicated in the operational section of this specification is not implied. Operation beyond the maximum operating conditions for extended periods may affect product reliability.

THERMAL RESISTANCE

Thermal performance is directly linked to printed circuit board (PCB) design and operating environment. Close attention to PCB thermal design is required.

θ_{JC} is the junction to case thermal resistance.

Table 5. Thermal Resistance

Package Type	θ_{JC}	Unit
CP-6-12	115.35	°C/W

POWER DERATING CURVES

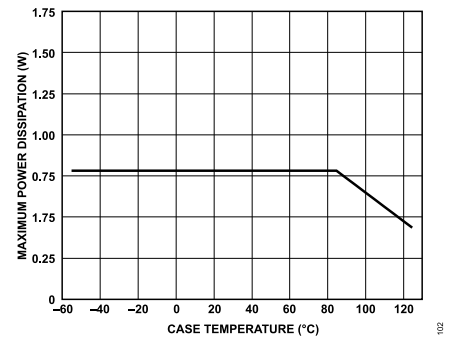

Figure 2. Maximum Power Dissipation vs. Case Temperature

[Figure 2](#) shows the maximum power dissipation vs. case temperature.

ESD CAUTION



ESD (electrostatic discharge) sensitive device. Charged devices and circuit boards can discharge without detection. Although this product features patented or proprietary protection circuitry, damage may occur on devices subjected to high energy ESD. Therefore, proper ESD precautions should be taken to avoid performance degradation or loss of functionality.

PIN CONFIGURATION AND FUNCTION DESCRIPTIONS

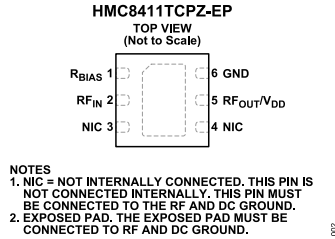

Figure 3. Pin Configuration

Table 6. Pin Function Descriptions

Pin No.	Mnemonic	Description
1	R _{BIAS}	Current Mirror Bias Resistor Pin. Use this pin to set the current to the internal resistor by the external resistor. See Figure 4 for the interface schematic.
2	RF _{IN}	RF Input. This pin is ac-coupled and matched to 50 Ω. See Figure 5 for the interface schematic.
3, 4	NIC	Not Internally Connected. This pin is not connected internally. This pin must be connected to the RF and dc ground.
5	RF _{OUT} /V _{DD}	Radio Frequency Output (RF _{OUT}). This pin is ac-coupled and matched to 50 Ω. See Figure 6 for the interface schematic. Drain Bias for the Amplifier (V _{DD}). This pin is ac-coupled and matched to 50 Ω. See Figure 6 for the interface schematic.
6	GND EPAD	Ground. This pin must be connected to the RF and dc ground. See Figure 7 for the interface schematic. Exposed Pad. The exposed pad must be connected to RF and dc ground.

INTERFACE SCHEMATICS

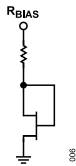

Figure 4. R_{BIAS} Interface Schematic

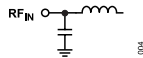

Figure 5. RF_{IN} Interface Schematic



Figure 6. RF_{OUT}/V_{DD} Interface Schematic



Figure 7. GND Interface Schematic

TYPICAL PERFORMANCE CHARACTERISTICS

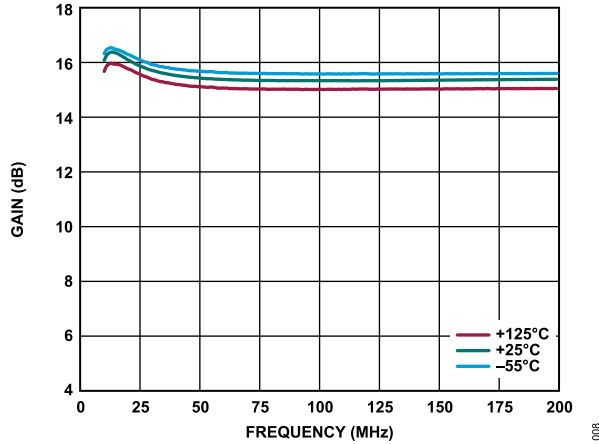

Figure 8. Gain vs. Frequency, 10 MHz to 200 MHz, for Various Temperatures, $V_{DD} = 5\text{ V}$, $I_{DQ} = 55\text{ mA}$

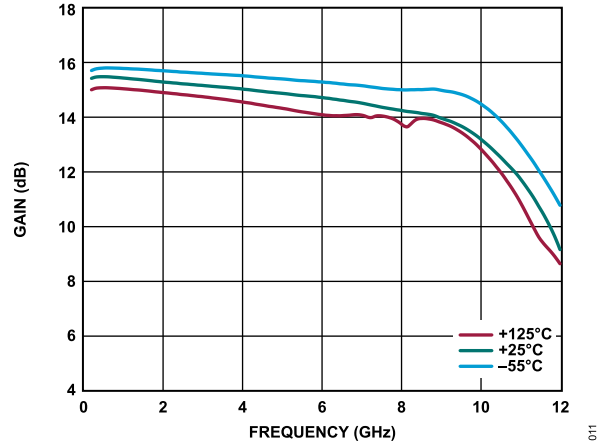

Figure 11. Gain vs. Frequency, 200 MHz to 12 GHz, for Various Temperatures, $V_{DD} = 5\text{ V}$, $I_{DQ} = 55\text{ mA}$

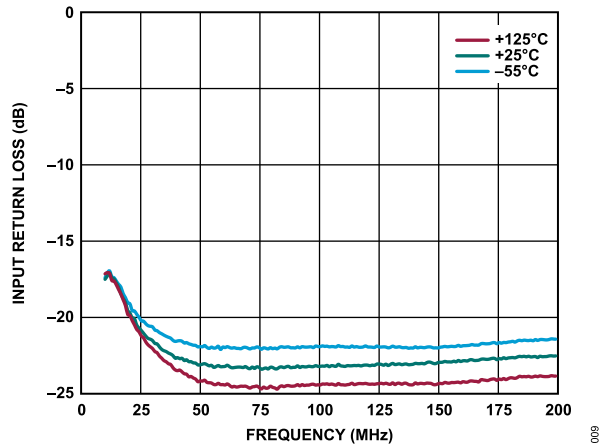

Figure 9. Input Return Loss vs. Frequency, 10 MHz to 200 MHz, for Various Temperatures, $V_{DD} = 5\text{ V}$, $I_{DQ} = 55\text{ mA}$

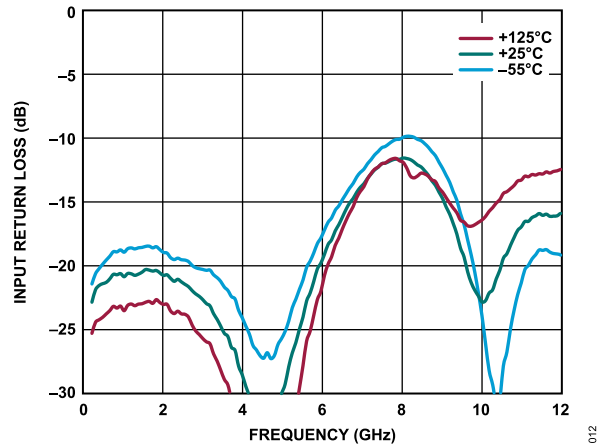

Figure 12. Input Return Loss vs. Frequency, 200 MHz to 12 GHz, for Various Temperatures, $V_{DD} = 5\text{ V}$, $I_{DQ} = 55\text{ mA}$

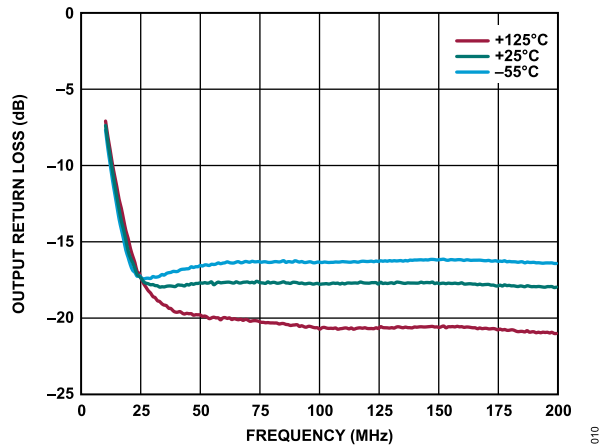

Figure 10. Output Return Loss vs. Frequency, 10 MHz to 200 MHz, for Various Temperatures, $V_{DD} = 5\text{ V}$, $I_{DQ} = 55\text{ mA}$

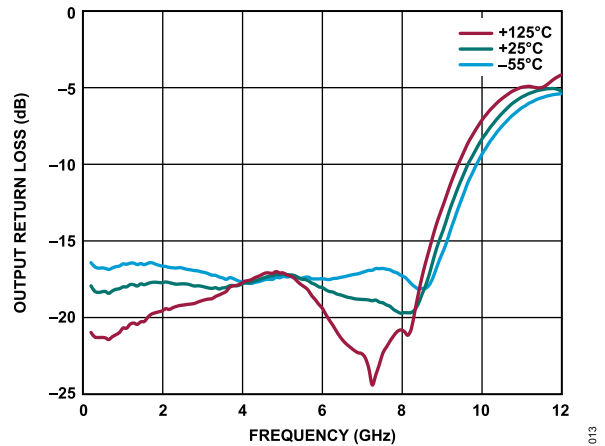

Figure 13. Output Return Loss vs. Frequency, 200 MHz to 12 GHz, for Various Temperatures, $V_{DD} = 5\text{ V}$, $I_{DQ} = 55\text{ mA}$

TYPICAL PERFORMANCE CHARACTERISTICS

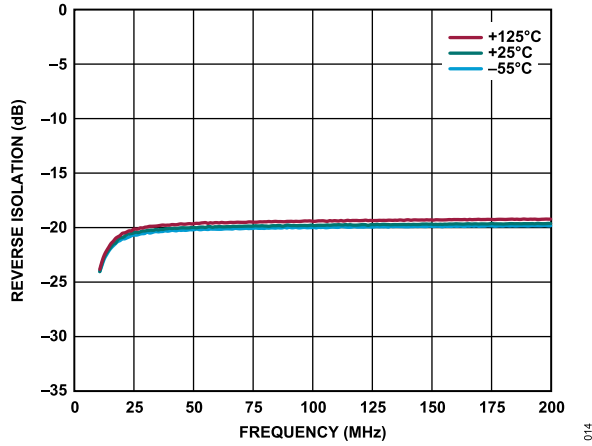

Figure 14. Reverse Isolation vs. Frequency, 10 MHz to 200 MHz, for Various Temperatures, $V_{DD} = 5\text{ V}$, $I_{DQ} = 55\text{ mA}$

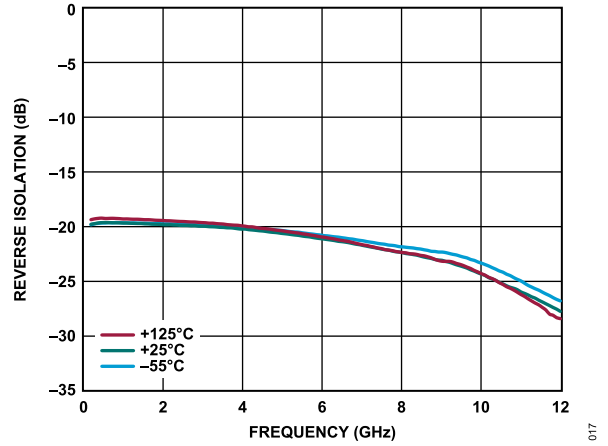

Figure 17. Reverse Isolation vs. Frequency, 200 MHz to 12 GHz, for Various Temperatures, $V_{DD} = 5\text{ V}$, $I_{DQ} = 55\text{ mA}$

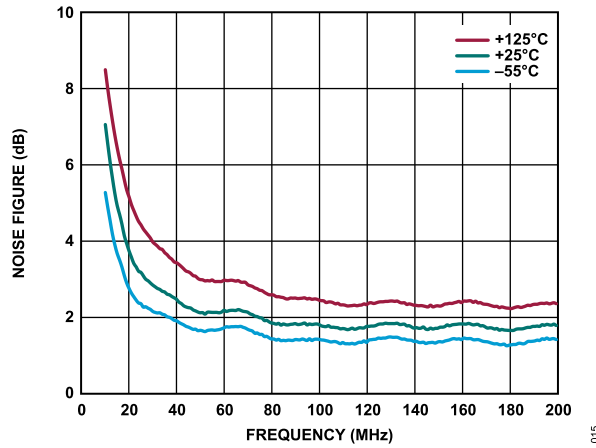

Figure 15. Noise Figure vs. Frequency, 10 MHz to 200 MHz, for Various Temperatures, $V_{DD} = 5\text{ V}$, $I_{DQ} = 55\text{ mA}$

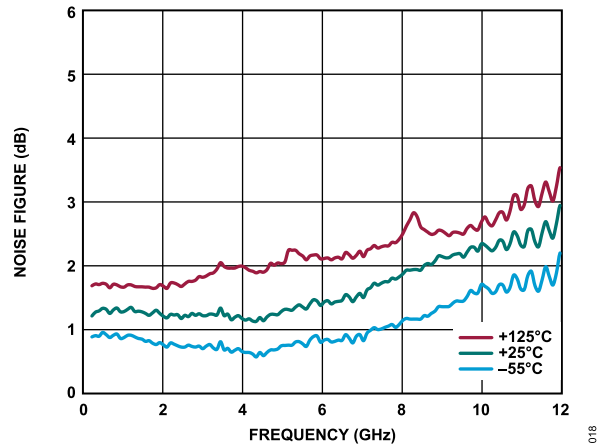

Figure 18. Noise Figure vs. Frequency, 200 MHz to 12 GHz, for Various Temperatures, $V_{DD} = 5\text{ V}$, $I_{DQ} = 55\text{ mA}$

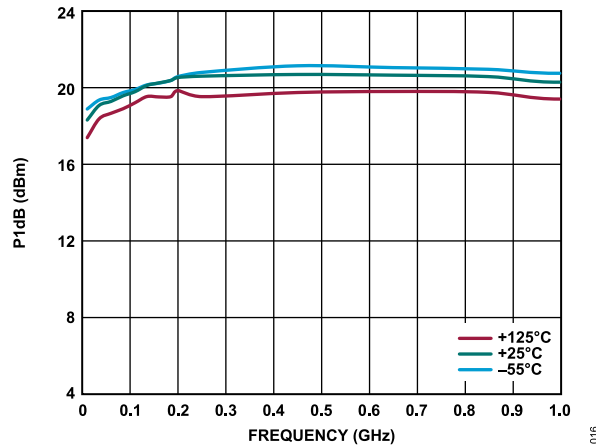

Figure 16. P1dB vs. Frequency, 0.01 GHz to 1.0 GHz, for Various Temperatures, $V_{DD} = 5\text{ V}$, $I_{DQ} = 55\text{ mA}$

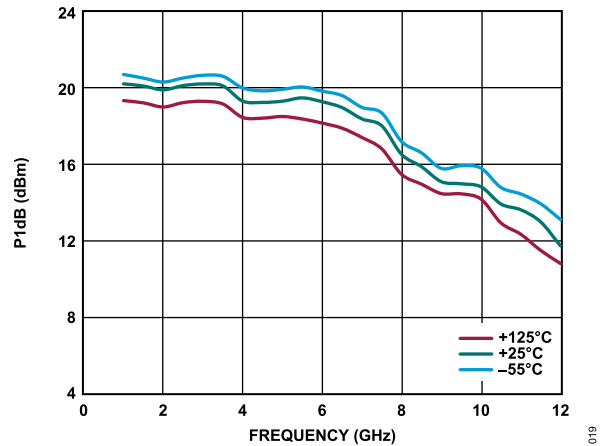

Figure 19. P1dB vs. Frequency, 1 GHz to 12 GHz, for Various Temperatures, $V_{DD} = 5\text{ V}$, $I_{DQ} = 55\text{ mA}$

TYPICAL PERFORMANCE CHARACTERISTICS

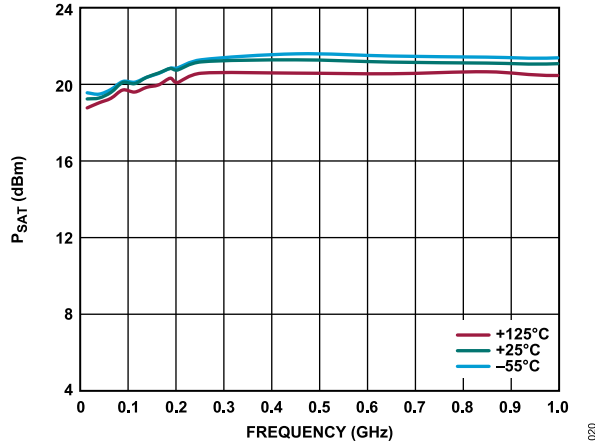

Figure 20. P_{SAT} vs. Frequency, 0.01 GHz to 1.0 GHz, for Various Temperatures, $V_{DD} = 5\text{ V}$, $I_{DQ} = 55\text{ mA}$

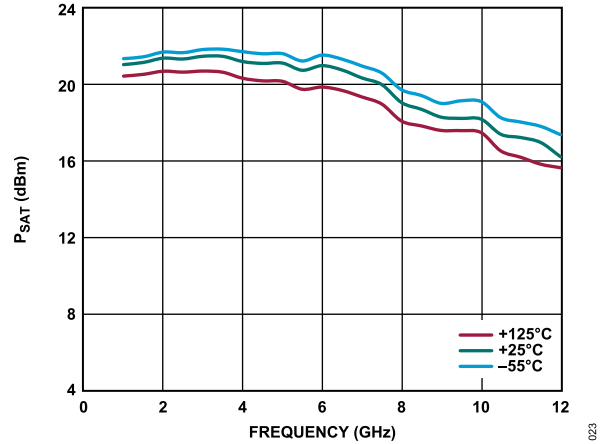

Figure 23. P_{SAT} vs. Frequency, 1 GHz to 12 GHz, for Various Temperatures, $V_{DD} = 5\text{ V}$, $I_{DQ} = 55\text{ mA}$

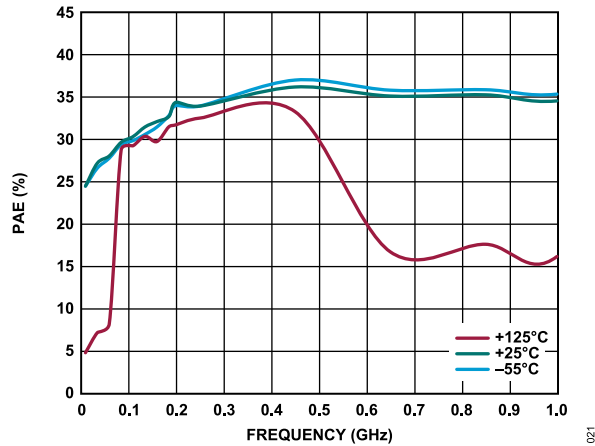

Figure 21. PAE vs. Frequency, 0.01 GHz to 1.0 GHz, for Various Temperatures, $V_{DD} = 5\text{ V}$, $I_{DQ} = 55\text{ mA}$

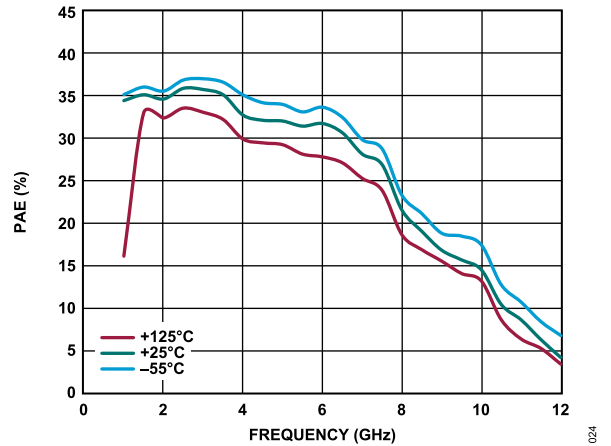

Figure 24. PAE vs. Frequency, 1 GHz to 12 GHz, for Various Temperatures, $V_{DD} = 5\text{ V}$, $I_{DQ} = 55\text{ mA}$

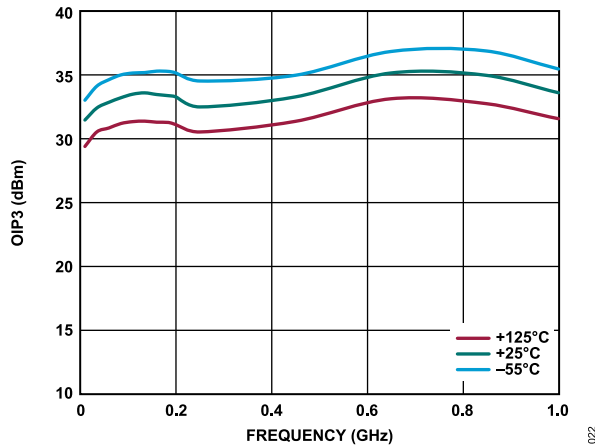

Figure 22. OIP3 vs. Frequency, 0.01 GHz to 1.0 GHz, for Various Temperatures, $V_{DD} = 5\text{ V}$, $I_{DQ} = 55\text{ mA}$

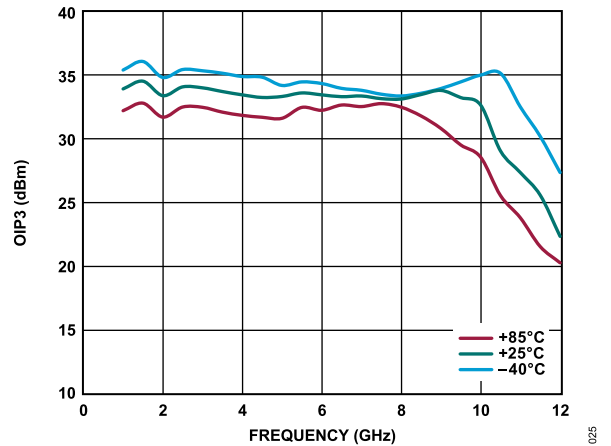

Figure 25. OIP3 vs. Frequency, 1 GHz to 12 GHz, for Various Temperatures, $V_{DD} = 5\text{ V}$, $I_{DQ} = 55\text{ mA}$

TYPICAL PERFORMANCE CHARACTERISTICS

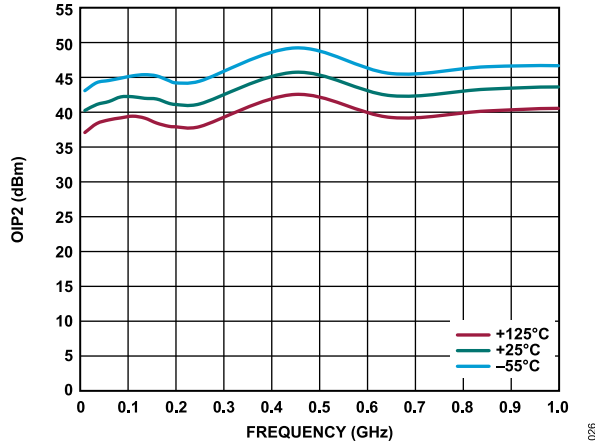

Figure 26. OIP2 vs. Frequency, 0.01 GHz to 1.0 GHz, for Various Temperatures, $V_{DD} = 5\text{ V}$, $I_{DQ} = 55\text{ mA}$

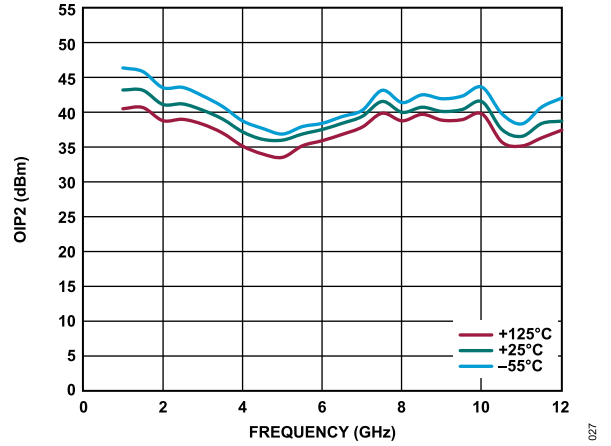
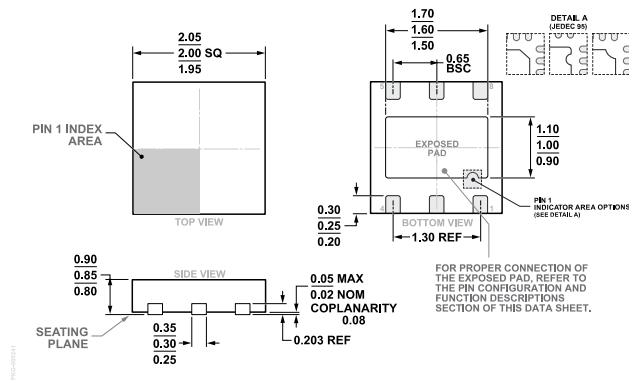

Figure 27. OIP2 vs. Frequency, 1 GHz to 12 GHz, for Various Temperatures, $V_{DD} = 5\text{ V}$, $I_{DQ} = 55\text{ mA}$

OUTLINE DIMENSIONS



**Figure 28. 6-Lead Lead Frame Chip Scale Package [LFCSP]
2 mm × 2 mm Body and 0.85 mm Package Height
(CP-6-12)
Dimensions shown in millimeters**

ORDERING GUIDE

Model ¹	Temperature Range	MSL Rating ²	Package Description ³	Package Option
HMC8411TCPZ-EP-PT	-55°C to +125°C	MSL1	6-Lead Lead Frame Chip Scale Package [LFCSP]	CP-6-12
HMC8411TCPZ-EP-R7	-55°C to +125°C	MSL1	6-Lead Lead Frame Chip Scale Package [LFCSP]	CP-6-12

- ¹ The HMC8411TCPZ-EP-PT and HMC8411TCPZ-EP-R7 are RoHS compliant parts.
- ² See the [Absolute Maximum Ratings](#) section for additional information.
- ³ The lead finish of the HMC8411TCPZ-EP-PT and HMC8411TCPZ-EP-R7 is nickel palladium gold (NiPdAu).

Looking for pricing, stock, or lifecycle information?

Click below to explore more details on WIN SOURCE:

 [View HMC8411TCPZ-EP-PT on WIN SOURCE](#)

 [Analog Devices Inc. Information](#)

Optimize Your Supply Chain with WIN SOURCE Solutions

-  Global Sourcing Solution
-  Obsolete Management
-  Cost Control Management
-  Shortage Management
-  Alternative Solution
-  Excess Inventory Management