



**THE DATASHEET OF
EVAL-ADAU1787Z**



Evaluating the **ADAU1787** Four-ADC, Two-DAC, Low Power Codec with Audio DSPs

EVALUATION KIT CONTENTS

EVAL-ADAU1787Z evaluation board
EVAL-ADUSB2EBZ (USBi) communications adapter
USB cable with mini USB plug

DOCUMENTS NEEDED

ADAU1787 data sheet
EVAL-ADAU1787Z user guide

GENERAL DESCRIPTION

This user guide explains the design and setup of the EVAL-ADAU1787Z evaluation board.

This evaluation board provides access to all analog and digital inputs/outputs on the **ADAU1787**. The **ADAU1787** core is

controlled by Analog Devices, Inc., **SigmaStudio**® software, which interfaces to the EVAL-ADAU1787Z via a USB connection. The EVAL-ADAU1787Z can be powered by the USB bus or by a single 3.8 V to 5 V supply. Any of these supplies are regulated to the voltages required on the EVAL-ADAU1787Z. The printed circuit board (PCB) is a 6-layer design, with a ground plane and a power plane on the inner layers. The EVAL-ADAU1787Z contains connectors for external microphones and speakers. The master clock can be provided externally or by the on-board 24.576 MHz passive crystal.

Multifunction pin names may be referenced by their relevant function only, for example, MPx, throughout this user guide.

EVAL-ADAU1787Z PHOTOGRAPH

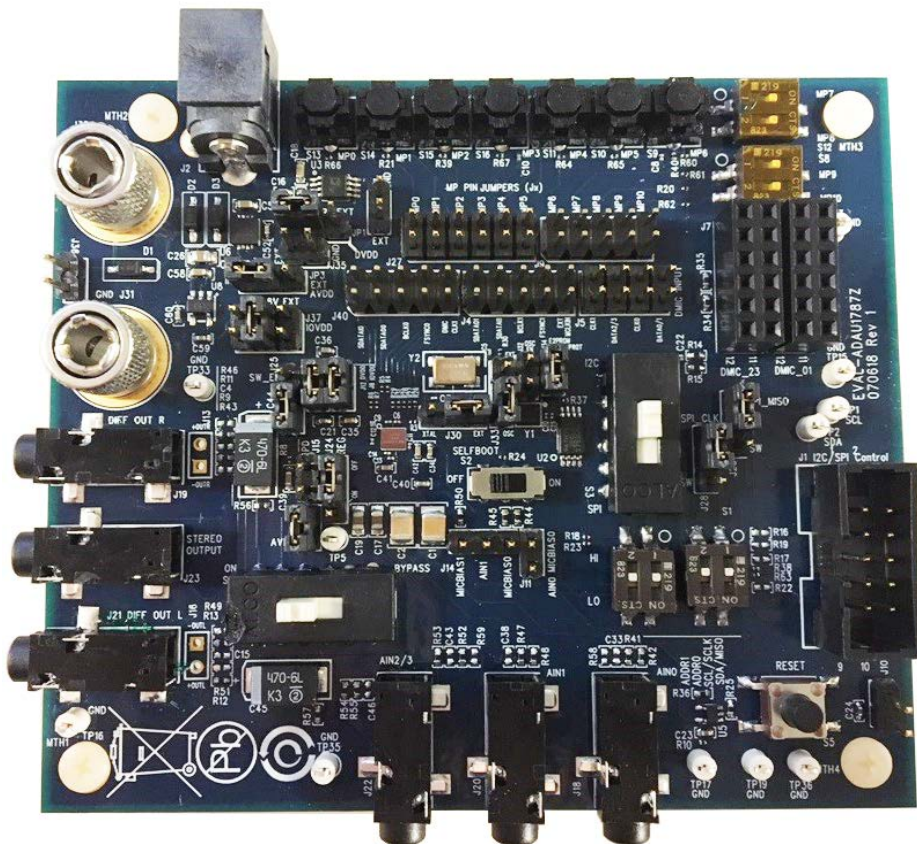

Figure 1.

TABLE OF CONTENTS

Evaluation Kit Contents.....	1	Initialization Sequences.....	8
Documents Needed.....	1	Custom Boot Sequence.....	9
General Description.....	1	Self Boot.....	9
EVAL-ADAU1787Z Photograph.....	1	Using the Evaluation Board.....	12
Revision History.....	2	Power.....	12
Evaluation Board Block Diagrams.....	3	Inputs and Outputs.....	12
Setting Up the Evaluation Board.....	4	MPx Pins.....	12
Installing the SigmaStudio Software.....	4	Serial Audio Interface.....	13
Installing the USBi (EVAL-ADUSB2EBZ) Drivers.....	4	Communications Header (J1).....	13
Default Switch and Jumper Settings.....	6	Power-Down.....	13
Master Clock Options.....	6	Hardware Description.....	14
Powering Up the Board.....	7	Jumpers.....	14
Connecting the Audio Cables.....	7	Evaluation Board Schematics and Artwork.....	15
Setting Up Communications in SigmaStudio.....	7	Ordering Information.....	21
Creating a Basic Signal Flow.....	8	Bill of Materials.....	21
Downloading the Program to the DSP.....	8		

REVISION HISTORY

4/2019—Revision 0: Initial Version

EVALUATION BOARD BLOCK DIAGRAMS

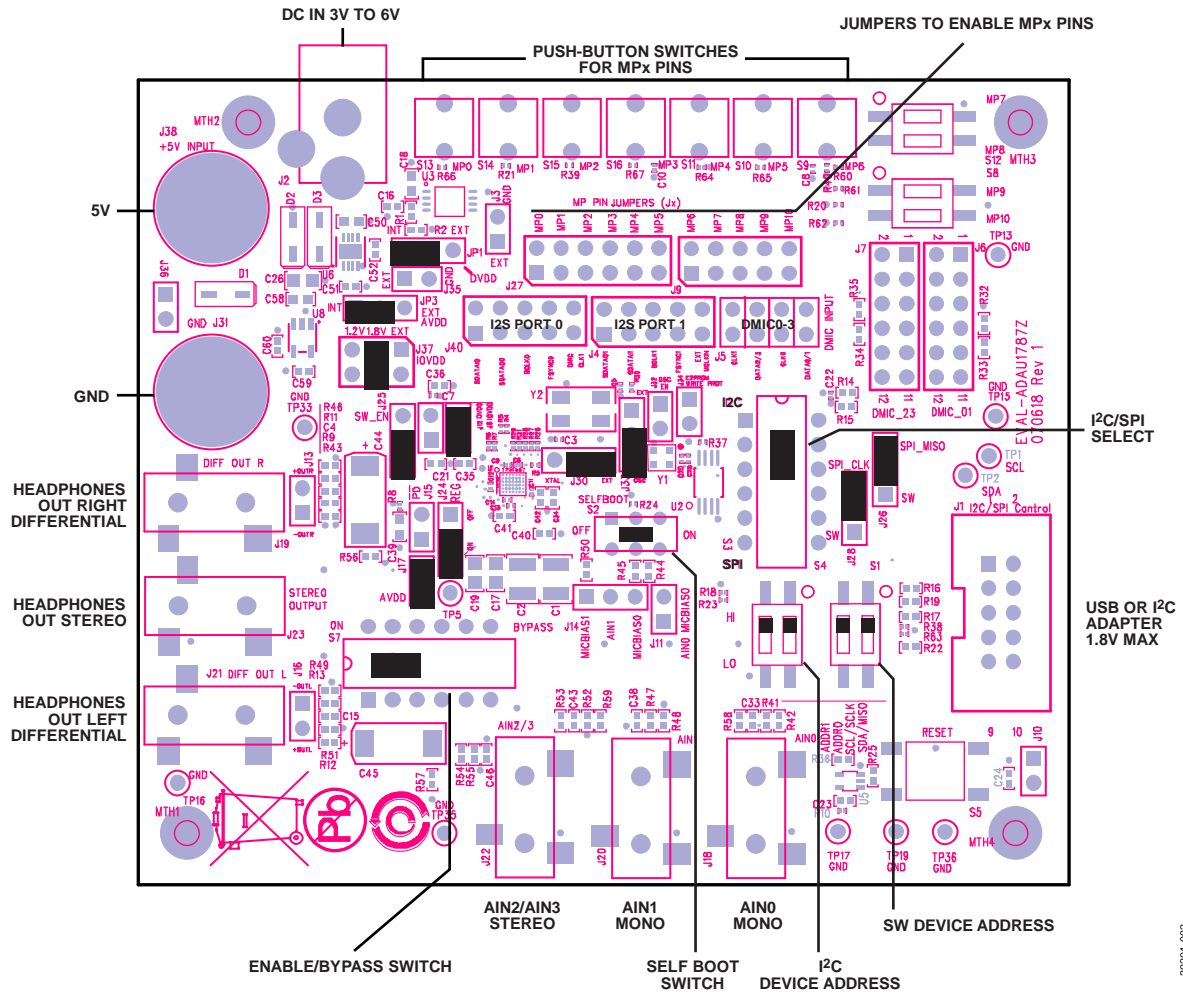

Figure 2. Default Jumper and Switch Settings (Solid Black Rectangle Indicates a Switch or Jumper Position)

202001-002

SETTING UP THE EVALUATION BOARD

INSTALLING THE SigmaStudio SOFTWARE

Download and install the latest version of SigmaStudio by completing the following steps:

1. Install the latest version of Microsoft® .NET framework if it is not already installed on the PC. The latest version of the .NET framework can be downloaded from the Microsoft website.
2. Go to www.analog.com/SigmaStudio and download the latest version of SigmaStudio from the **Downloads And Related Software** section.
3. Download the installer and run the executable file. Follow the prompts, including accepting the license agreement, to install the software.

INSTALLING THE USBi (EVAL-ADUSB2EBZ) DRIVERS

SigmaStudio must be installed to use the USB interface (USBi). After the SigmaStudio installation is complete, perform the following steps:

1. Connect the USBi to an available USB 2.0 port using the USB cable included in the evaluation board kit (the USBi does not function properly with a USB 3.0 port).
2. Install the driver software (see the Using Windows XP section or the Using Windows 7 or Windows Vista section for more information).

Using Windows XP

After connecting the USBi to the USB 2.0 port, Windows® XP recognizes the device (see Figure 3) and prompts the user to install the drivers.



Figure 3. Found New Hardware Notification

Use the Found New Hardware Wizard to complete the installation of the drivers. The installation of the drivers is shown in the following steps:

1. From the Found New Hardware Wizard window, select the **Install from a list or specific location (Advanced)** option and click **Next** (see Figure 4).

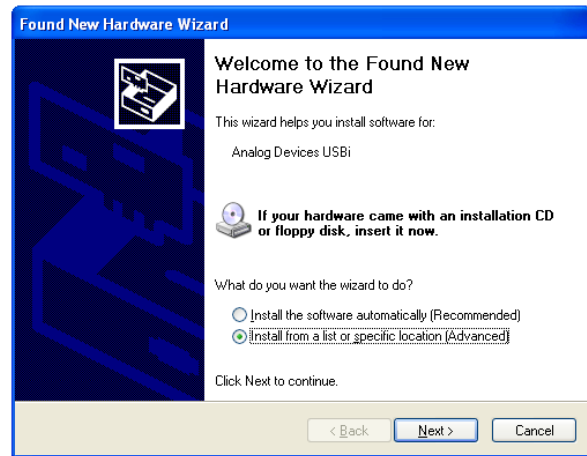

Figure 4. Found New Hardware Wizard: Installation

2. After Step 1 is completed, select **Search for the best driver in these locations**, select **Include this location in the search**, and click **Browse** to find the USB drivers subdirectory within the SigmaStudio directory (see Figure 5).

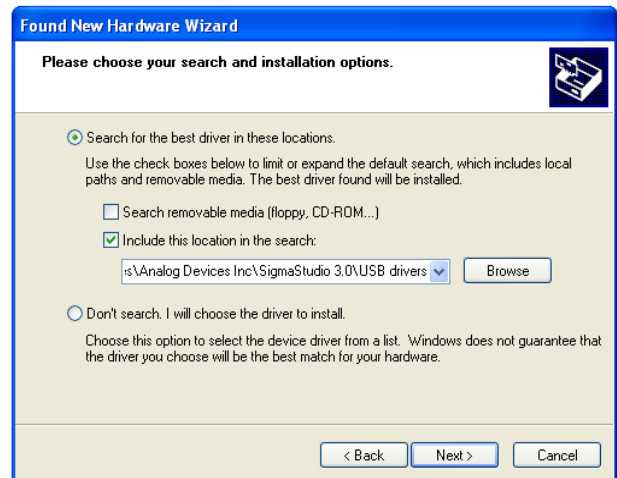

Figure 5. Found New Hardware Wizard: Search and Installation Options

- When the **Hardware Installation** warning appears, click **Continue Anyway** (see Figure 6).



Figure 6. Hardware Installation Warning

The USBi drivers are now installed. Leave the USBi connected to the PC.

Using Windows 7 or Windows Vista

After connecting the USBi to the USB 2.0 port, Windows 7 or Windows Vista recognizes the device and installs the drivers automatically (see Figure 7). After the installation is complete, leave the USBi connected to the PC.

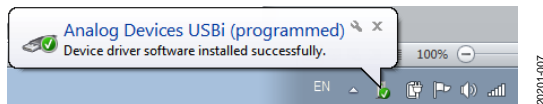

Figure 7. USBi Drivers Installed Correctly

Confirming Proper Installation of the USBi Drivers

To confirm that the USBi drivers have been installed properly, complete the following steps:

- With the USBi still connected to the USB 2.0 port of the PC, check that both the yellow I²C LED and the red power indicator LED are illuminated (see Figure 8).

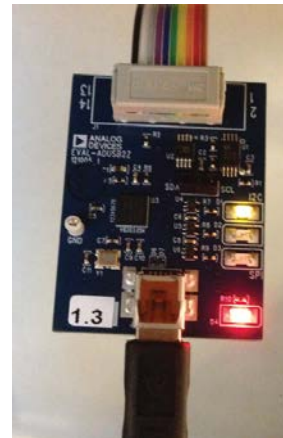

Figure 8. State of USBi Status LEDs After Driver Installation

- In the Windows **Device Manager**, under the **Universal Serial Bus controllers** section, check that **Analog Devices USBi (programmed)** appears as shown in Figure 9.

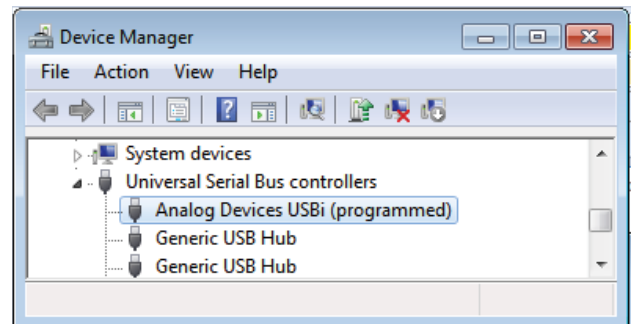

Figure 9. Confirming Driver Installation Using the **Device Manager**

DEFAULT SWITCH AND JUMPER SETTINGS

The JP3, JP1, and J37 jumpers are used to set the AVDD, DVDD, and IOVDD supply to the [ADAU1787](#). The external supply must be connected either to J2, or across J38 (+5V) and J31 (GND). The MPx pin jumpers (J9 and J27) can be connected as desired to use the MPx push-buttons or switches. The microphone bias jumpers, J11 and J14, can be connected if microphone bias is needed on the AIN0 and/or AIN1 inputs.

Switch S7 selects whether the EVAL-ADAU1787Z is to be powered up or if audio is to be bypassed from input to output with the EVAL-ADAU1787Z powered down. For normal operation, slide the switch to the left. Ensure that the switch on the bottom of the USBi board is set to the correct voltage of

1.8 V. Switch S2 controls the self boot operation. By default, S2 is set to the off position to disable the self boot operation.

MASTER CLOCK OPTIONS

The EVAL-ADAU1787Z has three options for providing a master clock (MCLK) to the [ADAU1787](#).

The first option is to provide an external MCLK signal directly to the XTALI/MCLKIN pin of the codec. The second option is to use the on-board 24.576 MHz oscillator and route it to the XTALI/MCLKIN pin of the codec. The third and final option is to use another on-board 24.576 MHz crystal in conjunction with the internal crystal oscillator of the [ADAU1787](#).

Table 1 shows the jumper settings for all three of these options.

Table 1. MCLK Jumper Settings

Clock Source	J30	J32	J33	J4
24.576 MHz External Oscillator	EXT	Open	OSC	Not applicable
On-Chip Crystal (XTAL) Oscillator	XTAL	Not applicable	Not applicable	Not applicable
External MCLK	EXT	Not applicable	EXT	Connect: MCLK (Pin 9) and GND (Pin 10)

POWERING UP THE BOARD

To power up the evaluation board, connect the ribbon cable of the USBi board to J1 (control port) of the EVAL-ADAU1787Z.

CONNECTING THE AUDIO CABLES

Connect a stereo audio source to J22 (AIN2 and AIN3). Note that the headphone outputs are differential and are dc-coupled. Connect the balanced headphones to J21 for the left channel and J19 for the right channel. If using a single-ended stereo headphone, it can be connected to J23. The J23 outputs are ac-coupled.

SETTING UP COMMUNICATIONS IN SigmaStudio

Start **SigmaStudio** by double clicking the shortcut on the desktop.

Click **File** and then click **New Project**, or press Ctrl + N to create a new project, as shown in Figure 10. The default view of the new project is the **Hardware Configuration** tab.

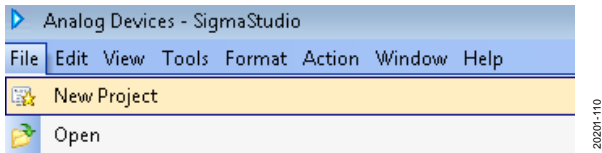

Figure 10. New Project

To use the USBi in conjunction with **SigmaStudio**, go to the **Communication Channels** subsection of the toolbox on the left side of the **Hardware Configuration** tab, select **USBi**, and drag it to the right to add it to the project space (see Figure 11).

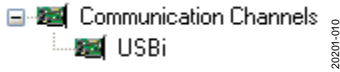

Figure 11. Adding the USBi Communication Channel

If **SigmaStudio** cannot detect the USBi board on the USB port of the PC, the background of the **USB** label is red (see Figure 12). The label can turn red when the USBi is not connected or when the drivers are incorrectly installed.



Figure 12. USBi Not Detected by SigmaStudio

If **SigmaStudio** detects the USBi board on the USB port of the PC, the background of the **USB** label changes to green (see Figure 13).

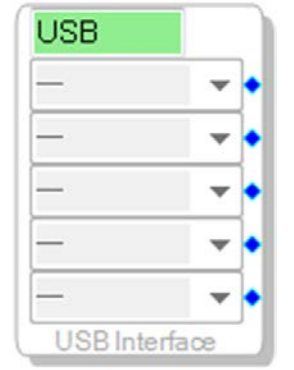

Figure 13. USBi Detected by SigmaStudio

To add an **ADAU1787** to the project, select **ADAU1787** from the **Processors (ICs / DSPs)** list and drag it to the project space (see Figure 14).

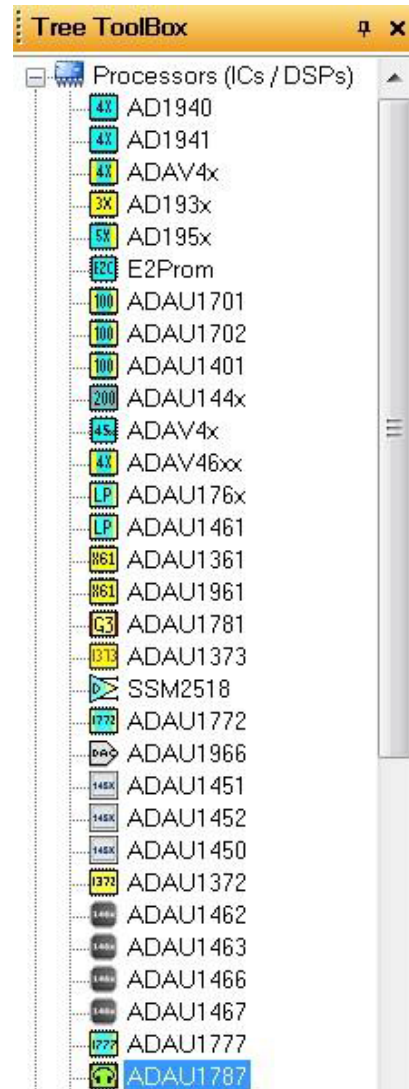

Figure 14. Adding an ADAU1787

To use the USBi board to communicate with the target IC, connect the IC by clicking and dragging a wire between the blue pin of the USBi and the green pin of the IC (see Figure 15). The corresponding dropdown box of the USBi automatically fills with the default mode and channel for that IC.

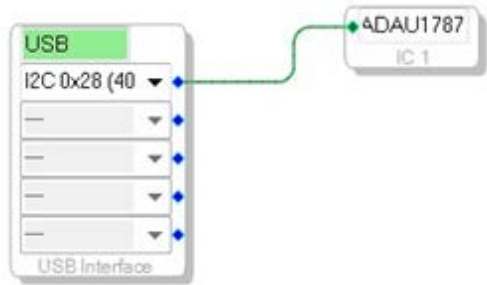

Figure 15. Connecting the USB Interface to an ADAU1787 IC

CREATING A BASIC SIGNAL FLOW

A schematic must be created with the desired signal path for the ADAU1787. Click the **Schematic** tab, as shown in Figure 16.

Under **Tree Toolbox**, icons can be selected and dragged into the schematic window, as shown in Figure 16. Note that there are two sets of icons, one set for the sigma digital signal processor (SDSP) and one set for the fast digital signal processor (FDSP). If routing an icon to or from the SDSP, icons from the **(IC 1-Sigma) ADAU1787S** section must be used. Otherwise, if routing an icon to or from the FDSP, icons from the **(IC 1-Fast) ADAU1787F** section must be used. In this example, AIN2 and AIN3 are being routed to the SDSP output (SDSP OUT1 and SDSP OUT2) so that the SDSP icons are chosen for that path. Likewise, AIN0 and AIN1 are being routed to the FDSP output (Output1 and Output2) so that the FDSP icons are chosen for that path. Depending on which DSP path is chosen, a corresponding color is applied to the routes. SDSP paths are yellow whereas FDSP paths are blue. Note that the SDSP and FDSP outputs can be routed to a variety of places within the codec, including to the DAC.

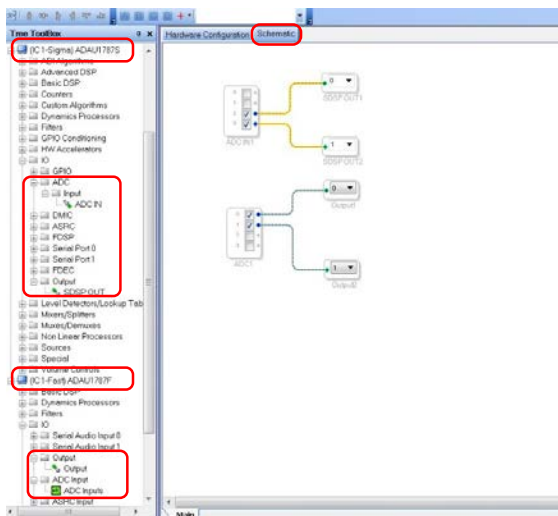

Figure 16. AIN2 and AIN3 Inputs to **SDSP OUT1** and **SDSP OUT2**, AIN0 and AIN1 Inputs to **FDSP Output1** and **Output2**

Go to the **Hardware Configuration** tab. In the bottom left corner, click the **IC 1 - ADAU1787 Register Control** tab (see Figure 17).



Figure 17. IC 1 - ADAU1787 Register Control Tab

The register control tab has multiple subtabs that control different sections of the ADAU1787. In Figure 18, the **POWER_CTRL** tab is shown, which allows the power-up or power-down of various blocks within the codec. Using each of the available tabs at the top of the window and GUI buttons throughout the codec, register settings can be programmed at a high level.

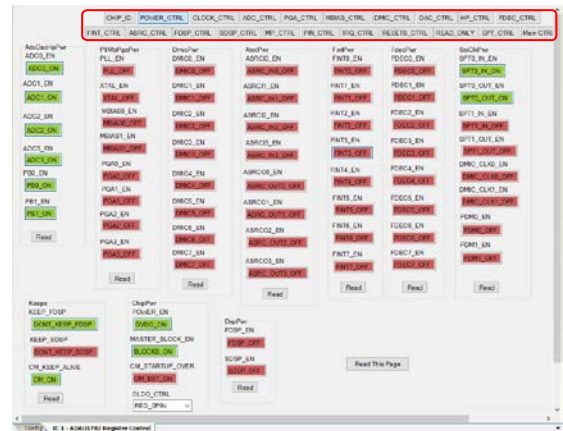

Figure 18. ADAU1787 **POWER_CTRL** Tab (Register Control)

DOWNLOADING THE PROGRAM TO THE DSP

To compile and download the code to the DSP, click the **Link Compile Download** icon in the main toolbar of **SigmaStudio** (see Figure 19). Alternatively, press the F7 key.



Figure 19. **Link Compile Download**

If the project does not compile correctly, an error displays. If an error displays, return to **SigmaStudio** and check the configuration for mistakes.

When the project compiles, the signal flow runs on the EVAL-ADAU1787Z, and the audio passes from the input to the output. The volume can be changed in real time by using the buttons on the EVAL-ADAU1787Z.

INITIALIZATION SEQUENCES

The ADAU1787 has specific sequencing requirements regarding register writes made after a device power-up. For a list of the full sequencing requirements, see the ADAU1787 data sheet.

To ensure that projects are downloaded with the proper sequencing, **SigmaStudio** incorporates a default sequence of register writes when selecting the **Link Compile Download** icon. However, **SigmaStudio** also grants the option to use a custom sequence, or to use no sequence at all.

To select the desired initialization sequence, find the **Config** tab and right click the **ADAU1787** icon. From there, an option appears to use the default boot sequence or to use a custom boot sequence. If using the custom boot sequence, two subsequent options appear: **Choose Boot Sequence** or **No Sequence File Needed**. If **No Sequence File Needed** is selected, no initial register writes are completed by **SigmaStudio** upon download. This selection means that it is up to the user to properly configure the **ADAU1787** after power-up, because no default writes are made after power-up.

If **Choose Boot Sequence** is selected, a pop up appears to select the desired .xml file. Note that .xml files must be generated or loaded to create a custom boot sequence. This sequence is described in the Custom Boot Sequence section. Figure 21 and Figure 22 also provide additional details on this process.

Unless changed, the link compile download function uses the default sequence, as shown in Figure 20.

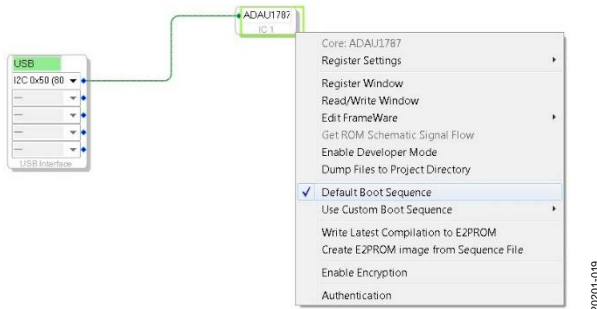

Figure 20. Default Boot Sequence

CUSTOM BOOT SEQUENCE

To use a custom boot sequence, the custom .xml file of register writes must be executed first. Click **View**, then **Capture Window** at the top of the window to ensure that the capture window is visible. Select the right arrow to show **Display Sequence Window**, as shown in Figure 21.

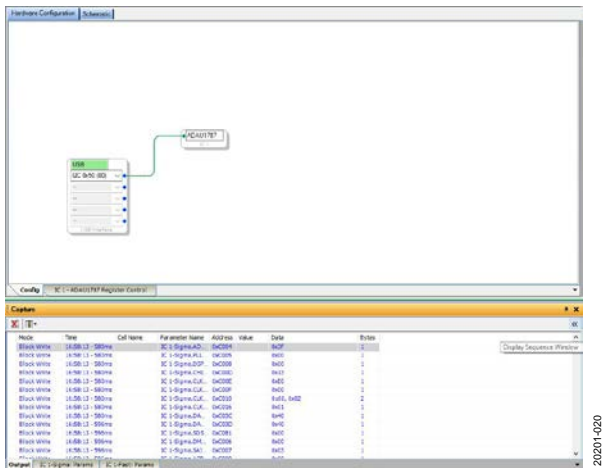

Figure 21. Display Sequence Window

After clicking the **Link Compile Download** icon for this project, the **Capture Window** shows all of the captured register writes. These writes can be selected and dragged into the **Sequence Window** individually, circled in red in Figure 22. Note that a write can be manually added by right clicking the **Sequence Window** and selecting **Add Item**, then **Write**.

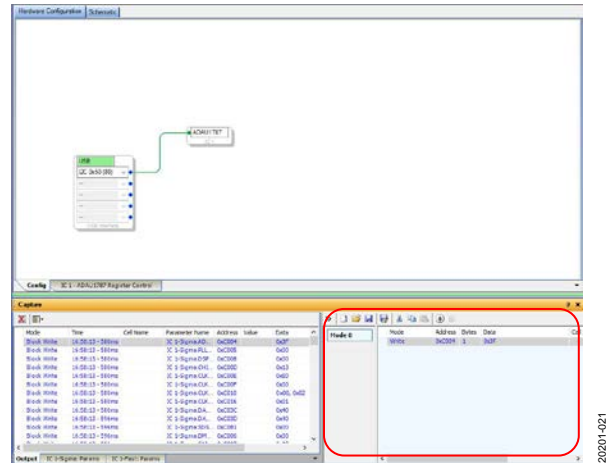

Figure 22. Sequence Window Register Write

After a complete sequence of desired register writes is added to the **Sequence Window**, select the disk icon (**Save Sequence File**), which saves the list of register writes as an .xml file.

After a custom boot sequence is created, it can also be written to the on-board electronically erasable programmable read only memory (EEPROM) so that the sequence can be run in self boot mode at startup.

SELF BOOT

The **ADAU1787** has a self boot feature that, when enabled, allows the device to be programmed by reading I²C values via the EEPROM. This feature allows the device to have all the configuration registers, program data, and filter coefficients written together during boot-up. The EVAL-ADAU1787Z features an EEPROM that can store and deliver these values to the **ADAU1787** during self boot operation.

Before using the **SigmaStudio** software to write the EEPROM, some board level settings must be confirmed. Locate J34 and ensure that it is inserted, as shown in Figure 23. Having J34 inserted ensures that the EEPROM is not blocking write commands with a write protect. Next, locate S2 (SELFBOT), as shown in Figure 23. While programming the EEPROM, set S2 to off. After the EEPROM is written, this switch can be set to on, and on the next reset the switch boots up with the values stored in the EEPROM. The codec can be reset either by the RESET switch, S3, shown in Figure 24, or by a full power-on reset. After either of these reset conditions, the codec boots up with the values stored in the EEPROM programmed to it.

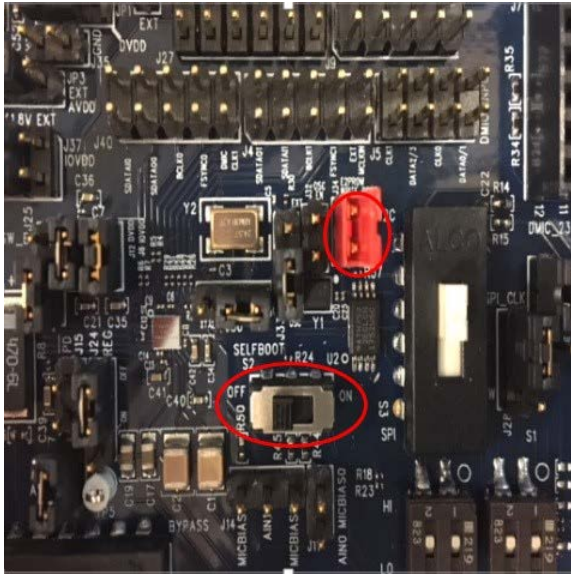

Figure 23. SELFBOOT and Write Protect (WIP) Settings

20201-022

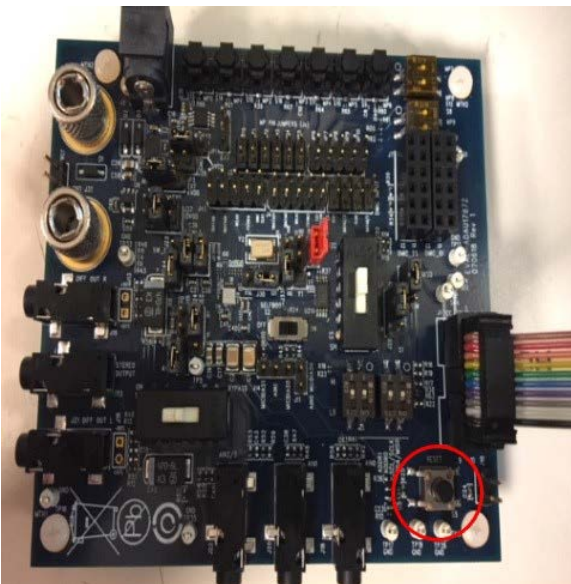

Figure 24. RESET Switch

20201-023

After the evaluation board level settings are confirmed, find the **Hardware Configuration** tab and drag an additional icon for the EEPROM to the window. Then drag the USBi icon, and connect it to the two devices, as shown in Figure 25. Ensure that the device address is 0xA0 for the EEPROM.

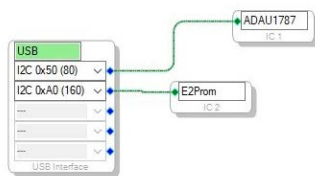

Figure 25. EEPROM Icon

20201-024

Right click the **E2Prom** icon and select **Properties**. When **Properties** is selected, a prompt opens to input the EEPROM properties, as shown in Figure 26. Ensure that all the input values match the ones shown in Figure 26.

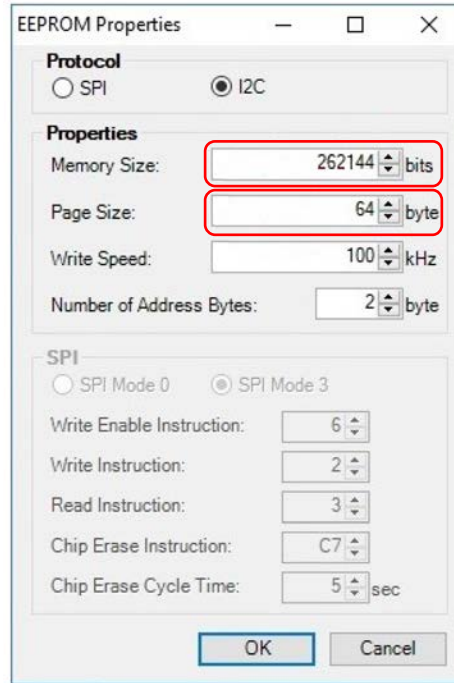

Figure 26. EEPROM Properties

20201-025

After the EEPROM is configured, the initialization sequence settings of the project must be set within the **Config** tab. In this example, no initialization sequence is chosen, as shown in Figure 27.

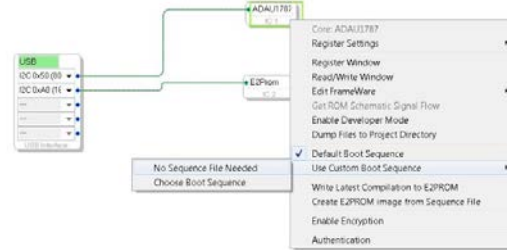
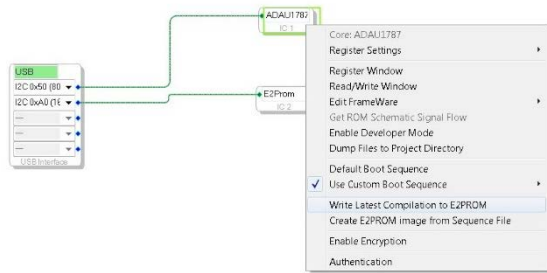

Figure 27. Choose **No Sequence File Needed**

20201-026

Next, the project must be compiled by clicking the **Link Compile Download** icon to ensure that the latest settings of the project are stored and available to be written to the EEPROM. After the **Link Compile Download** icon is clicked, return to the **Config** tab and right click the **ADAU1787** icon, selecting **Write Latest Compilation to E2PROM**, as shown in Figure 28. A prompt similar to Figure 26 opens, and enter values to match Figure 26. After the EEPROM properties are confirmed, click **OK**. A green status bar briefly appears, indicating write transactions.



20201-027

Figure 28. Write Latest Compilation to E2PROM

After the EEPROM has been written, set the SELFBOOT switch, S2, to on, and reset the device. The device can be reset by the RESET switch, S3, or by a full power-on reset. In this configuration, the device boots up with the desired values.

USING THE EVALUATION BOARD POWER

Power can be supplied to the EVAL-ADAU1787Z in one of three ways. The power can be supplied by connecting the [EVAL-ADUSB2EBZ](#) (USBi) board to J1 (see Figure 29), by connecting a 3.8 V dc to 5 V dc power supply to J2 (tip positive), or using Binding Post J38 (+5V) and J31 (GND).

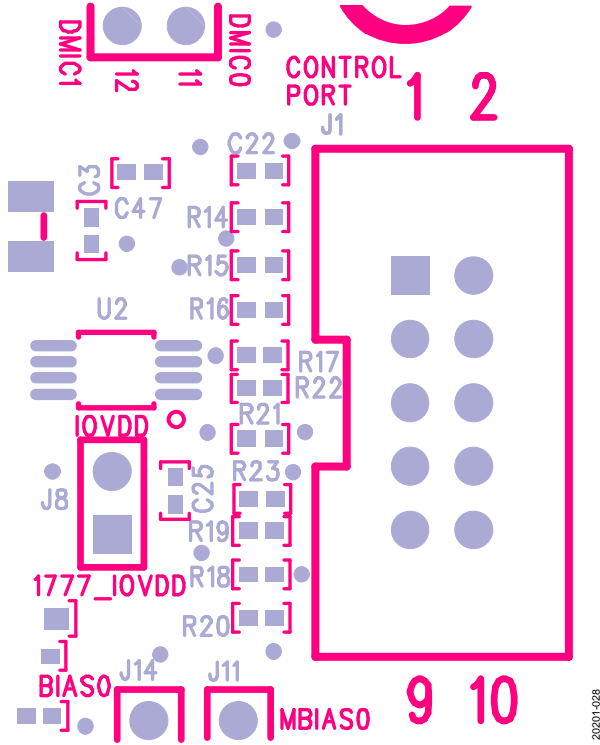

Figure 29. Header J1, Control Port

The on-board regulator generates the 1.8 V, 1.2 V, and 0.9 V dc supply. To connect power to the [ADAU1787](#), connect the J8, J10, J12, and J17 jumpers (see Figure 2).

INPUTS AND OUTPUTS

The EVAL-ADAU1787Z has multiple audio input and output options, including digital and analog. There are four single-ended analog inputs that are configurable as microphone or line inputs, dual stereo digital microphone inputs, and two differential outputs that can also be used in a single-ended configuration.

Analog Microphone Inputs

For microphone signals, the [ADAU1787](#) analog inputs can be configured as single-ended inputs with an optional programmable gain amplifier (PGA) mode.

Microphone Bias

To add MBIAS0 to AIN0, connect a jumper to the J11 header. Similarly, MBIAS1 or MBIAS0 can be added to AIN1 by connecting a jumper to the J14 header (see Figure 2).

Stereo Line Input

The J22 stereo input jack accepts a standard 3.5 mm stereo jack (tip is left, ring is right) with two channels of audio.

Digital Microphones

Pulse density modulation (PDM) digital microphones can be connected to standard 0.100 in. headers (J5). To use the digital microphone headers on the EVAL-ADAU1787Z, ensure that the proper settings have been chosen in [SigmaStudio](#).

Headphone/Line Output

The headphone output, J23, connects to any standard 3.5 mm mini plug stereo headphones. The output pins can be set as a line output driver or as a headphone driver. In line output mode, the typical load is 10 k Ω . In headphone output mode, the typical loads are 16 Ω to 32 Ω .

Headphones can be driven either single-ended (J23) or differentially on J21 (left channel) and J19 (right channel).

MPx PINS

The MPx pin jumpers, Header J9 and Header J27, provide access to the MPx pins (MP0 to MP8) of the [ADAU1787](#), as well as facilitate the use of the push-buttons on the EVAL-ADAU1787Z board. See Figure 2 for the pinout of the header. These jumpers enable the use of the volume control, mute, and other capabilities of the [ADAU1787](#).

To use the full functionality of the MPx pins on the [ADAU1787](#), change the selections in the dropdown boxes under the **MP_CTRL** tab and **PIN_CTRL** tab, shown in Figure 30 and Figure 31, which are located in the **Hardware Configuration** tab of [SigmaStudio](#).

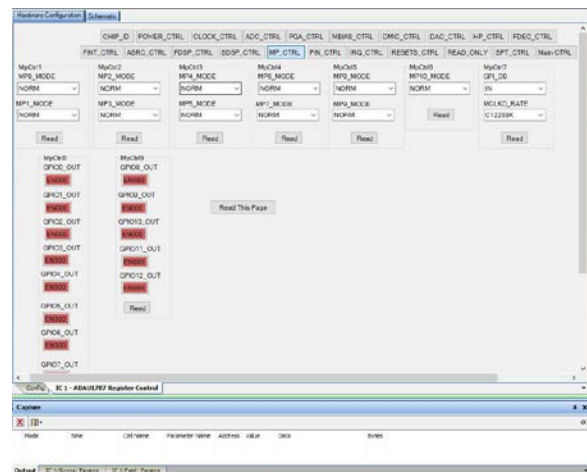

Figure 30. MP_CTRL Tab

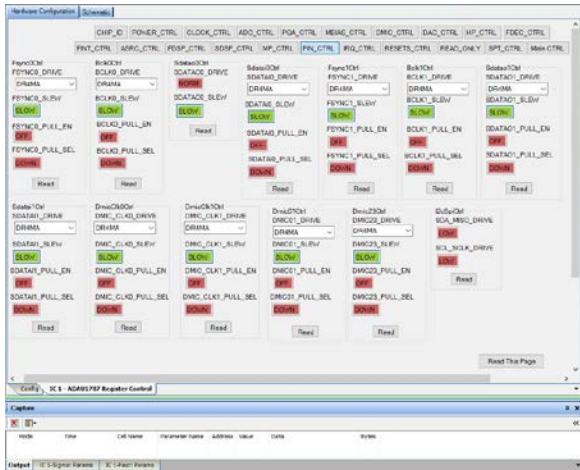

Figure 31. PIN_CTRL Tab

SERIAL AUDIO INTERFACE

Serial audio signals in I²S, left justified, right justified, or time division multiplexed (TDM) format are available via the Serial Audio Interface Header J4 and Serial Audio Interface Header J40. J40 is for Serial Port 0, and J4 is for Serial Port 1. J4 and J40 also include the option to connect an external I²S/TDM compatible device. The default IOVDD logic level is 1.8 V.

TDM/I²S Stream

To use the serial audio outputs, connect the FSYNC_x, BCLK_x, and SDATA_x lines to the appropriate MP_x pins on the evaluation board. The connections are located on the J4 header. The silk screen above the header helps to identify where to connect the clocks and data (see Figure 32).

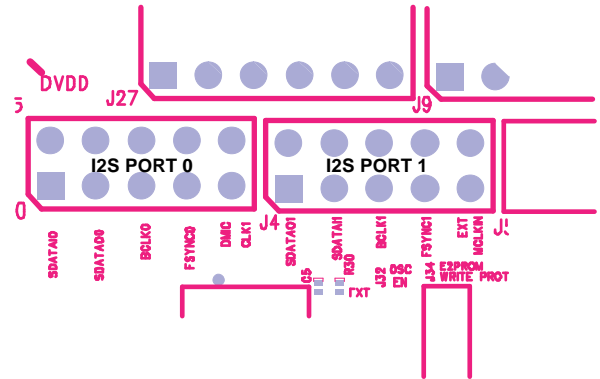

Figure 32. Serial Audio Port

COMMUNICATIONS HEADER (J1)

J1 connects to the EVAL-ADUSB2EBZ USBi. More information about the USBi can be found in the AN-1006 Application Note.

The EVAL-ADAU1787Z is configured to I²C mode by default. To operate the codec in SPI mode, S3 must be set to SPI instead of I²C. Additionally, R16, R17, and R22 must be installed. By default, these resistors are open. Note that the on-board EEPROM supports I²C only. Therefore, the EEPROM can only be written in I²C mode.

POWER-DOWN

The power-down header, J15 (PD), on the silkscreen of the board provides access to the power-down pin on the ADAU1787. Place a jumper on the header to power down all analog and digital circuits. Before enabling PD, mute the outputs to avoid any pops or clicks when the IC is powered down.

HARDWARE DESCRIPTION

JUMPERS

Table 2. Connector and Jack Descriptions

Reference Designator	Functional Name	Description
J1	Control port	Header that facilitates communication between the evaluation board and USBi board.
J2	5 V dc input	Barrel jack that provides external power to the board. J2 accepts a 3.8 V dc to 6 V dc input.
J3	External DVDD	Used to connect the external DVDD supply to the board.
J4	Serial Audio Port 1	Input and output header for serial audio signals in I ² S, left justified, right justified, or TDM format.
J5	PDM digital microphone inputs	Headers that allow digital microphones to be connected to the evaluation board.
J6, J7	Digital microphone inputs	Female headers that allow external digital microphones to be connected to the EVAL-ADAU1787Z.
J8	IOVDD	Jumper connects power to the IOVDD supply of the ADAU1787 from the power supply section.
J9	MPx pin jumpers	Jumpers used to connect push-buttons on the board to the MPx pins on the ADAU1787.
J10	Reset	Header to generate the reset for the ADAU1787.
J11, J14	Microphone bias	Jumpers used to add a microphone bias to the analog microphone inputs, AIN0 and AIN1.
J12	DVDD regulator (REG)	Jumper connects the DVDD source to the ADAU1787. Leave this open if using an on-chip ADAU1787 DVDD regulator.
J13	Output right	Jumper provides access to the right channel mono differential output.
J15	Power down	Jumper used to power down the ADAU1787 analog and digital circuits.
J16	Output left	Jumper provides access to the left channel mono differential output.
J17	AVDD	Jumper connects AVDD to the ADAU1787.
J18	Analog Input 0	Single-ended input channel
J19	Output right	Right channel differential output 3.5 mm jack.
J20	Analog Input 1	Single-ended input channel.
J21	Output left	Left channel differential output 3.5 mm jack.
J22	Analog Input 2 and Analog Input 3	Stereo input channel 3.5 mm jack.
J23	Stereo output	Single-ended stereo output 3.5 mm jack.
J24	Regulator enable	Used for enabling or disabling the on-chip DVDD regulator.
J25	I ² C/SPI enable	Used to enable I ² C/SPI mode. Leave this connected to GND for normal mode.
J26	SPI MISO	Used to receive the SPI data from ADAU1787 (MISO) in SPI mode. Leave this connected, as shown in Figure 2.
J27	MPx pin jumper	Jumper used to connect push-buttons on the board to the MPx pins on the ADAU1787.
J28	SPI CLK	Used to provide the clock to the ADAU1787 in SPI mode. Leave this connected, as shown in Figure 2.
J30	External/crystal select	Used to select between routing the on-board crystal to the device or using an external clock signal to route to MCLK.
J31	GND	Connect to GND or 0 V of the power supply.
J32	Oscillator enable	Jumper for enabling or disabling the on-board oscillator. Remove to enable the oscillator.
J33	External/oscillator select	Used to select between using the on-board oscillator or the external master clock to route to the ADAU1787.
J34	Write protect EEPROM	Used to set the write protect for on-board EEPROM.
J35	External AVDD	Used to connect external AVDD supply to the board.
J36	+5V/GND	External header to connect 5 V and GND to board.
J37	IOVDD select	Used to select the IOVDD (1.8 V/1.2 V/EXT) to the ADAU1787.
J38	+5V	Used to connect external +5V supply to the board.
J40	Serial Audio Port 0	Input and output header for serial audio signals in I ² S, left justified, right justified, or TDM format.
JP1	External/internal DVDD select	Used to select between the external DVDD source or on-board regulator for DVDD.
JP3	External/internal AVDD select	Used to select between the external AVDD source or on-board regulator for AVDD.

EVALUATION BOARD SCHEMATICS AND ARTWORK

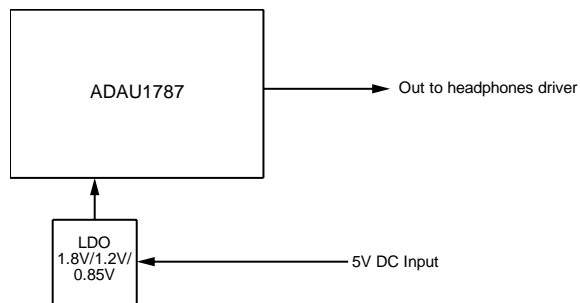

20201-030

Figure 33. EVAL-ADAU1787Z Schematic: Block Diagram

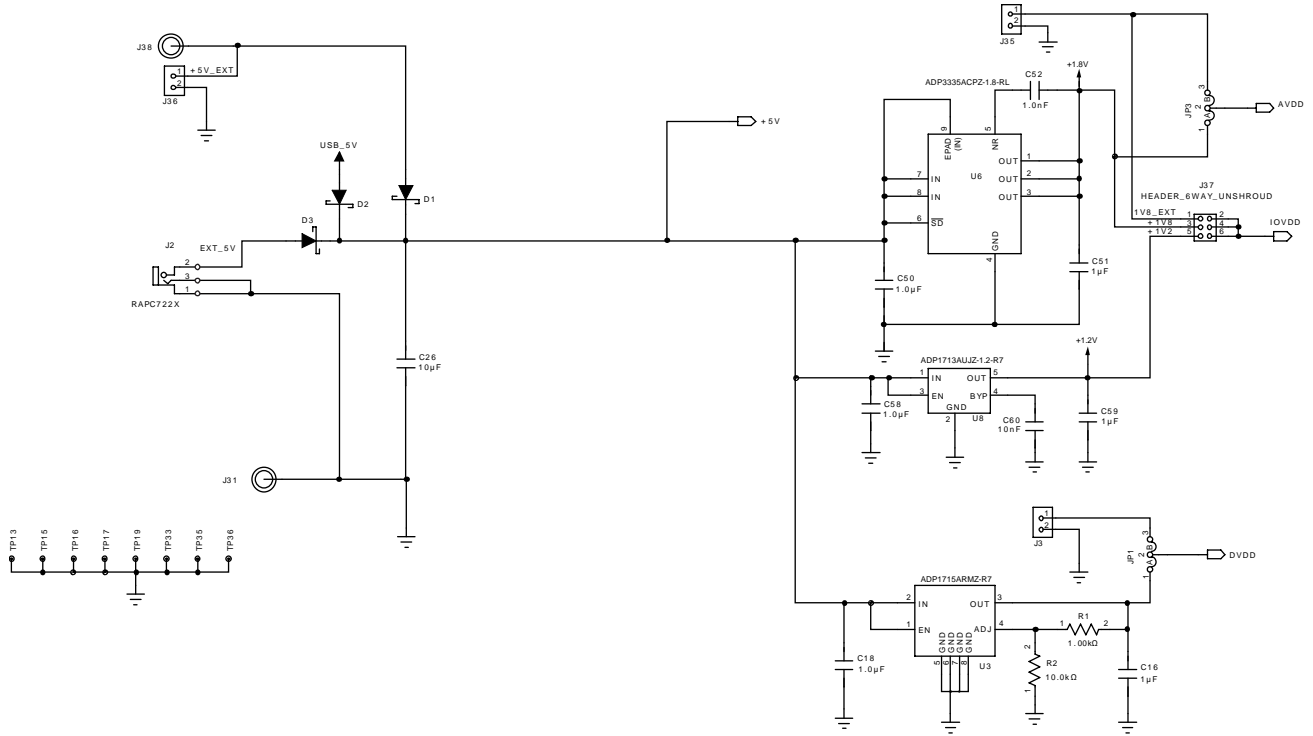

Figure 35. EVAL-ADAU1787Z Schematic: Power Supply

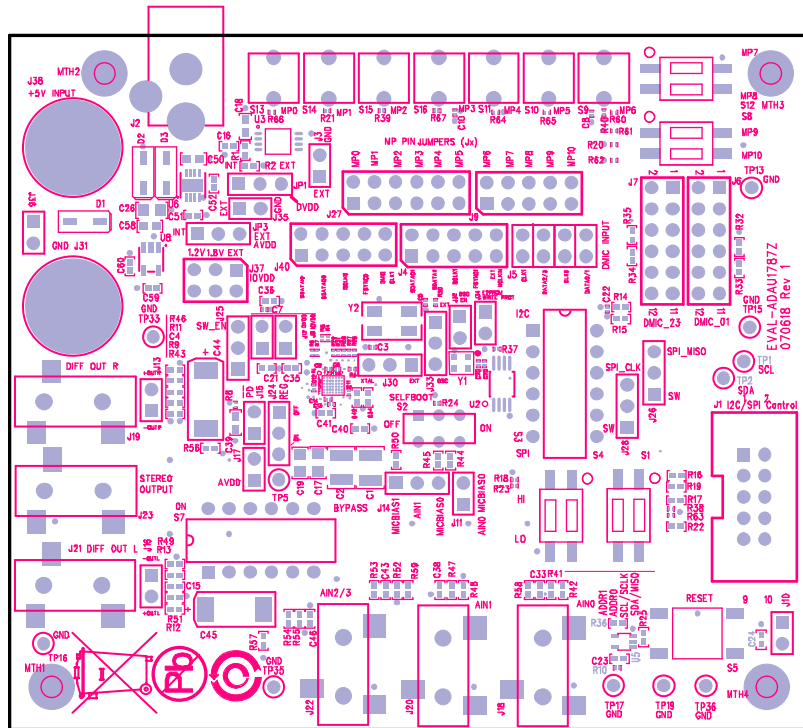
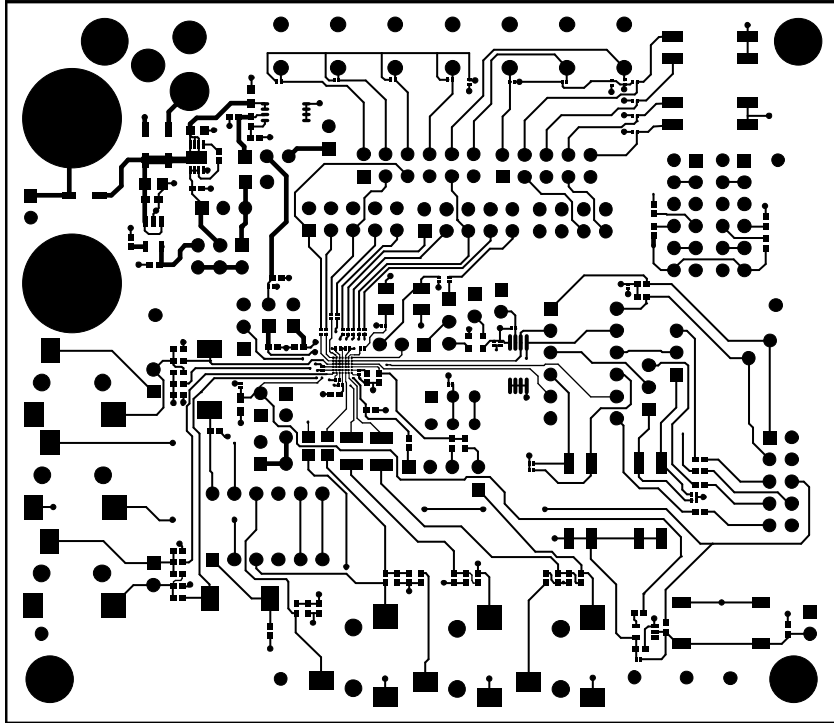
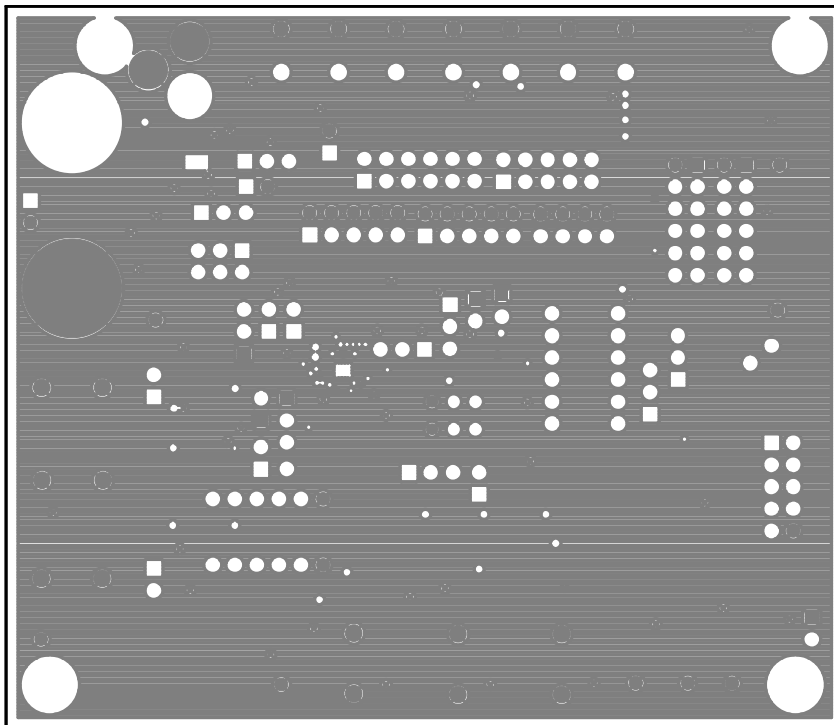

Figure 36. EVAL-ADAU1787Z Layout: Top Assembly



20201-034

Figure 37. EVAL-ADAU1787Z Layout: Top Copper



20201-035

Figure 38. EVAL-ADAU1787Z Layout: Ground Plane

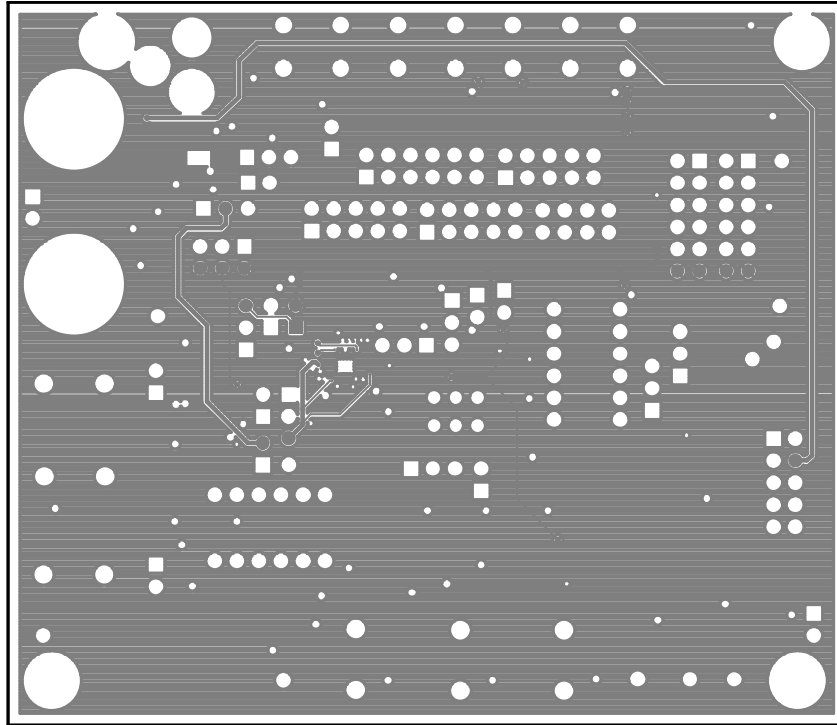

20201-036

Figure 39. EVAL-ADAU1787Z Layout: Power Plane

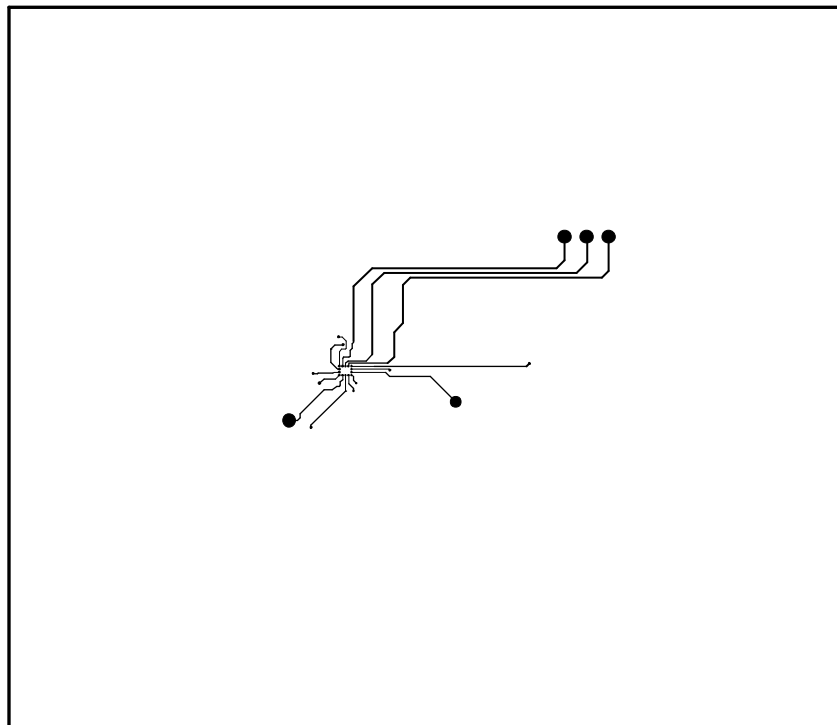

20201-037

Figure 40. EVAL-ADAU1787Z Layout: Layer 4 Copper

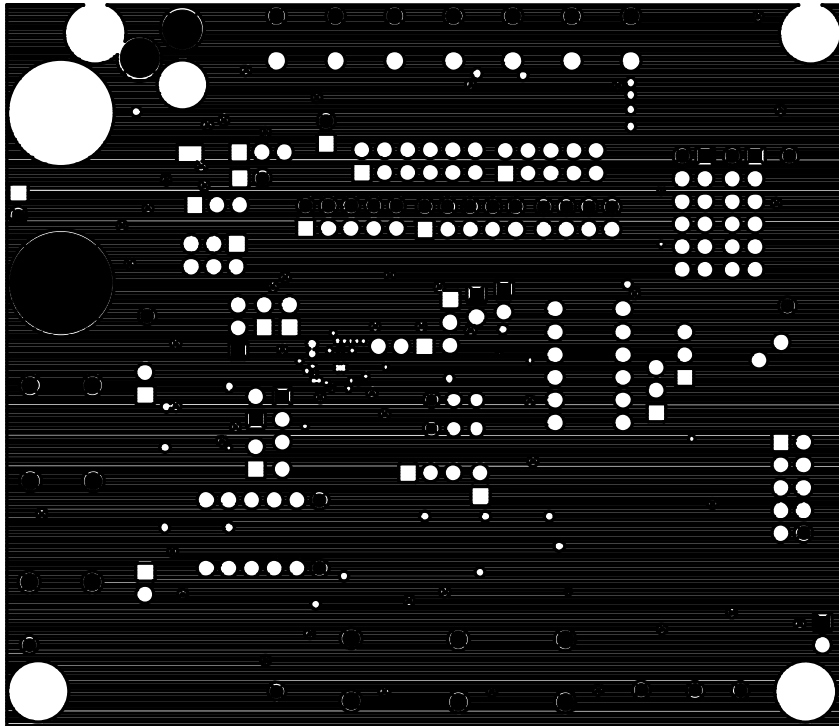

20201-038

Figure 41. EVAL-ADAU1787Z Layout: Layer 5 Copper

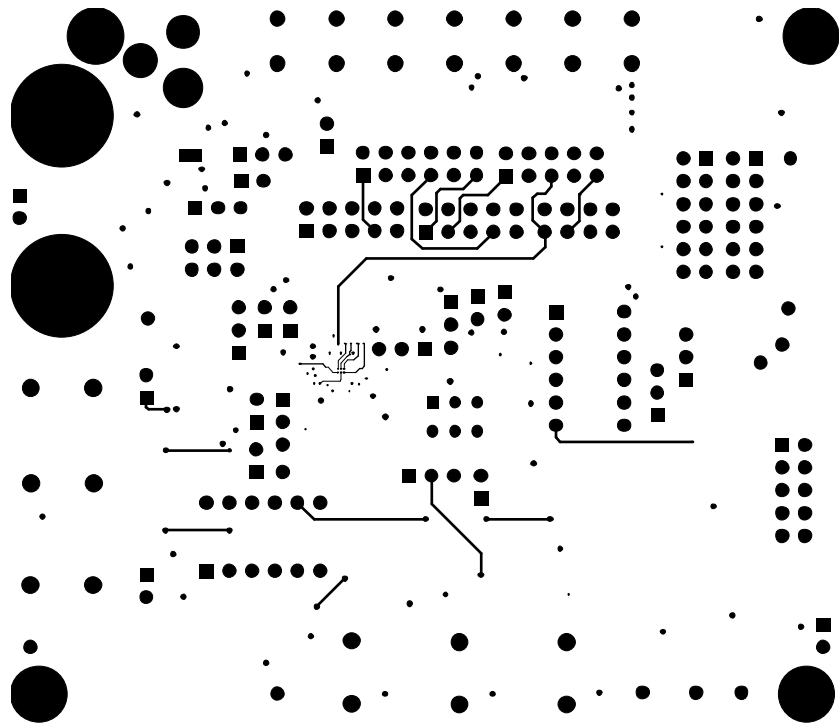

20201-038

Figure 42. EVAL-ADAU1787Z Layout: Layer 6 Bottom Copper

ORDERING INFORMATION

BILL OF MATERIALS

Table 3.

Qty	Reference	Description	Value	Vendor	Vendor Order Number
2	C1, C2	Ceramic capacitors, 47.0 µF, 6.3 V, X7R, 1210	47.0 µF	Analog Devices	490-4844-1-ND
2	C3, C5	Multilayer ceramic capacitors, 25 V, NP0, 0201	18 pF	Analog Devices	490-9659-1-ND
6	C4, C15, C33, C38, C43, C46	Multilayer ceramic capacitors, 6.3 V, X7R, 0402	Do not insert	Analog Devices	
12	C6 to C14, C20, C22, C25	Multilayer ceramic capacitors, 6.3 V, X5R, 0201	100 nF	Analog Devices	490-3167-1-ND
6	C16, C21, C34, C40, C51, C59	Multilayer ceramic capacitors, 6.3 V, X7R, 0402	1 µF	Analog Devices	311-1702-1-ND
3	C17, C19, C26	Multilayer ceramic capacitors, 10 V, X7R, 0805	10 µF	Analog Devices	490-3905-1-ND/ 445-6857-1-ND
3	C18, C50, C58	Multilayer ceramic capacitors, 16 V, X7R, 0603	1.0 µF	Analog Devices	490-3900-1-ND
2	C23, C24	Multilayer ceramic capacitors, 16 V, X7R, 0402	0.10 µF	Analog Devices	490-3261-1-ND
4	C35, C36, C41, C42	Multilayer ceramic capacitors, 6.3 V, X5R, 0402	10 µF	Analog Devices	490-13211-1-ND
1	C39	Multilayer ceramic capacitor, 16 V, X7R, 0603	NF	Analog Devices	587-1241-1-ND
2	C44, C45	SMD tantalum capacitors, Size D, 6.3 V	470 µF	Analog Devices	718-1559-1-ND
1	C52	Multilayer ceramic capacitor, 50 V, NP0, 0402	1.0 nF	Analog Devices	490-3244-1-ND
1	C60	Multilayer ceramic capacitor, 25 V, X7R, 0402	10 nF	Analog Devices	490-6340-1-ND
3	D1 to D3	Schottky, 30 V, 0.5 A, SOD123 diode	Schottky	Analog Devices	MBR0530T1GOSCT-ND
1	J1	10-way shroud polarized header	2×5	Analog Devices	MHC10K-ND
1	J2	Mini power jack, 0.08 in., right angle, through hole	RAPC722X	Analog Devices	SC1313-ND
3	J3, J35, J36	2-pin header unshrouded jumpers, 0.10 in., use Shunt Tyco 881545-2	2-Jumper	Analog Devices	S1011E-02-ND
3	J4, J9, J40	10-way (2×5) unshrouded 0.1 in. headers	2×5	Analog Devices	S2011EC-05-ND
1	J5	8-way unshrouded header dual row	2×4	Analog Devices	S2011E-04-ND, or cut S2011E-36-ND
2	J6, J7	12-way socket unshrouded	2×6	Analog Devices	S7109-ND
8	J8, J10 to J12, J15, J17, J32, J34	2-pin header unshrouded jumpers, 0.10 in., use Shunt Tyco 881545-2	2-Jumper	Analog Devices	S1011E-02-ND
2	J13, J16	2-pin header unshrouded jumpers, 0.10 in.	Do not insert	Analog Devices	S1011E-02-ND
9	J14, J24 to J26, J28, J30, J33, JP1, JP3	3-pin single inline position (SIP) header	3-Jumper	Analog Devices	S1011E-03-ND
6	J18 to J23	Stereo mini jack, SMT	SJ-3523-SMT	Analog Devices	CP-3523SJCT-ND
1	J27	12-way unshrouded	2×6	Analog Devices	S2011E-06-ND
2	J31, J38	Binding post mini uninsulated base through hole	Nickel binding post	Analog Devices	J587-ND
1	J37	6-way unshrouded header	2×3	Analog Devices	S2011E-03-ND

Qty	Reference	Description	Value	Vendor	Vendor Order Number
4	M1 to M4	Polarizing plugs for 0.10 in. socket	65754-001	Arrow Electronics	65754-001
4	MTH1 to MTH4	Nylon screw pan Phillips 4-40, 0.250 in.	4-40 mounting hole for standoff and panhead screw	Analog Devices	H542-ND
4	MTH1 to MTH4	Nylon hexagonal standoff 4-40, ½ in.	4-40 mounting hole for standoff and panhead screw	Analog Devices	36-1902C-ND
2	R1, R25	Chip resistors, 1%, 63 mW thick film, 0402	1.00 kΩ	Analog Devices	311-1.00KLRCT-ND
1	R2	Chip resistor, 1%, 100 mW thick film, 0402	10.0 kΩ	Analog Devices	P10.0KLCT-ND
1	R3	Chip resistor, 1%, 50 mW thick film, 0201	1.0 kΩ	Analog Devices	YAG3431CT-ND
10	R4 to R7, R26 to R31	Resistors, 33 Ω, 1/20 W, 5%, 0201 SMD	33 Ω	Analog Devices	311-33NCT-ND
1	R8	Chip resistor, 1%, 50 mW thick film, 0201	Do not insert	Analog Devices	YAG3431CT-ND
9	R9, R11 to R13, R36, R42, R48, R53, R54	Chip resistors, 5%, 63 mW thick film, 0402	0 Ω	Analog Devices	P0.0JCT-ND
2	R14, R15	Chip resistors, 1%, 63 mW thick film, 0402	2.67 kΩ	Analog Devices	541-2.67KLCT-ND
10	R16, R17, R19, R22, R43, R46, R49, R51, R58, R59	Chip resistors, 5%, 63 mW thick film, 0402	Do not insert		
6	R10, R18, R23, R24, R38, R63	Chip resistors, 1%, 50 mW thick film, 0201	10.0 kΩ	Analog Devices	311-10KNCT-ND
12	R20, R21, R37, R39, R40, R60 to R62, R64 to R67	Chip resistors, 1%, 50 mW thick film, 0201	10.0 kΩ	Analog Devices	311-10KNCT-ND
4	R32 to R35	Chip resistors, 1%, 63 mW thick film, 0402	10.0 kΩ	Analog Devices	RHM10.0KLCT-ND
6	R41, R47, R52, R55 to R57	Chip resistors, 1%, 63 mW thick film, 0402	49.9 kΩ	Analog Devices	541-49.9KLCT-ND
3	R44, R45, R50	Chip resistors, 1%, 63 mW thick film, 0402	2.00 kΩ	Analog Devices	P2.00KLCT-ND/ 311-2KLRCT-ND
4	S1, S4, S8, S12	Two-section SPST SMD switches raised act	2× SPST	Analog Devices	CT2192LPST-ND
1	S2	SPDT slide switch PC mount	SPDT	Analog Devices	EG1918-ND
2	S3, S7	Four-pole double throw (4PDT) slide switches, vertical break-before-make	4PDT slide	Analog Devices	450-1633-ND
1	S5	Tact switch 6 mm gull wing	SPST-NO	Analog Devices	450-1133-ND
7	S9 to S11, S13 to S16	Tact switches long stroke (normally open)	SPST-MOM	Analog Devices	SW426-ND
11	TP1, TP2, TP5, TP13, TP15 to TP17, TP19, TP33, TP35, TP36	Mini test point white, 0.1 in. diameter	5002	Analog Devices	5002K-ND
1	U1	Low latency audio codec ADAU1787	ADAU1787	Analog Devices	ADAU1787CBCZ
1	U2	256 kB I ² C CMOS serial EEPROM	AT24C256C-XHL-T	Analog Devices	AT24C256C-XHL-TCT-ND
1	U3	Adjustable low dropout voltage regulator	ADP1715ARMZ-R7	Analog Devices	ADP1715ARMZ-R7CT-ND
1	U5	Single bus noninverted buffer gate, open-drain, SC70-5	SN74AUC1G07DCKR	Analog Devices	296-12464-1-ND
1	U6	High accuracy, ultralow I _Q , 500 mA, low dropout regulator	ADP3335ACPZ-1.8-RL	Analog Devices	ADP3335ACPZ-1.8-R7CT-ND

Qty	Reference	Description	Value	Vendor	Vendor Order Number
1	U8	Fixed low dropout voltage regulator, 1.2 V	ADP1713AUJZ-1.2-R7	Analog Devices	ADP1713AUJZ-1.2-R7CT-ND
1	Y1	24.576 MHz fixed SMD oscillator, 1.8 V dc to 3.3 V dc	24.576 MHz	Analog Devices	535-11729-1-ND
1	Y2	Crystal, 24.576 MHz, ABM3B	24.576 MHz	Analog Devices	535-9127-1-ND

I²C refers to a communications protocol originally developed by Philips Semiconductors (now NXP Semiconductors).



ESD Caution

ESD (electrostatic discharge) sensitive device. Charged devices and circuit boards can discharge without detection. Although this product features patented or proprietary protection circuitry, damage may occur on devices subjected to high energy ESD. Therefore, proper ESD precautions should be taken to avoid performance degradation or loss of functionality.

Legal Terms and Conditions

By using the evaluation board discussed herein (together with any tools, components documentation or support materials, the "Evaluation Board"), you are agreeing to be bound by the terms and conditions set forth below ("Agreement") unless you have purchased the Evaluation Board, in which case the Analog Devices Standard Terms and Conditions of Sale shall govern. Do not use the Evaluation Board until you have read and agreed to the Agreement. Your use of the Evaluation Board shall signify your acceptance of the Agreement. This Agreement is made by and between you ("Customer") and Analog Devices, Inc. ("ADI"), with its principal place of business at One Technology Way, Norwood, MA 02062, USA. Subject to the terms and conditions of the Agreement, ADI hereby grants to Customer a free, limited, personal, temporary, non-exclusive, non-sublicensable, non-transferable license to use the Evaluation Board FOR EVALUATION PURPOSES ONLY. Customer understands and agrees that the Evaluation Board is provided for the sole and exclusive purpose referenced above, and agrees not to use the Evaluation Board for any other purpose. Furthermore, the license granted is expressly made subject to the following additional limitations: Customer shall not (i) rent, lease, display, sell, transfer, assign, sublicense, or distribute the Evaluation Board; and (ii) permit any Third Party to access the Evaluation Board. As used herein, the term "Third Party" includes any entity other than ADI, Customer, their employees, affiliates and in-house consultants. The Evaluation Board is NOT sold to Customer; all rights not expressly granted herein, including ownership of the Evaluation Board, are reserved by ADI. CONFIDENTIALITY. This Agreement and the Evaluation Board shall all be considered the confidential and proprietary information of ADI. Customer may not disclose or transfer any portion of the Evaluation Board to any other party for any reason. Upon discontinuation of use of the Evaluation Board or termination of this Agreement, Customer agrees to promptly return the Evaluation Board to ADI. ADDITIONAL RESTRICTIONS. Customer may not disassemble, decompile or reverse engineer chips on the Evaluation Board. Customer shall inform ADI of any occurred damages or any modifications or alterations it makes to the Evaluation Board, including but not limited to soldering or any other activity that affects the material content of the Evaluation Board. Modifications to the Evaluation Board must comply with applicable law, including but not limited to the RoHS Directive. TERMINATION. ADI may terminate this Agreement at any time upon giving written notice to Customer. Customer agrees to return to ADI the Evaluation Board at that time. LIMITATION OF LIABILITY. THE EVALUATION BOARD PROVIDED HEREUNDER IS PROVIDED "AS IS" AND ADI MAKES NO WARRANTIES OR REPRESENTATIONS OF ANY KIND WITH RESPECT TO IT. ADI SPECIFICALLY DISCLAIMS ANY REPRESENTATIONS, ENDORSEMENTS, GUARANTEES, OR WARRANTIES, EXPRESS OR IMPLIED, RELATED TO THE EVALUATION BOARD INCLUDING, BUT NOT LIMITED TO, THE IMPLIED WARRANTY OF MERCHANTABILITY, TITLE, FITNESS FOR A PARTICULAR PURPOSE OR NON-INFRINGEMENT OF INTELLECTUAL PROPERTY RIGHTS. IN NO EVENT WILL ADI AND ITS LICENSORS BE LIABLE FOR ANY INCIDENTAL, SPECIAL, INDIRECT, OR CONSEQUENTIAL DAMAGES RESULTING FROM CUSTOMER'S POSSESSION OR USE OF THE EVALUATION BOARD, INCLUDING BUT NOT LIMITED TO LOST PROFITS, DELAY COSTS, LABOR COSTS OR LOSS OF GOODWILL. ADI'S TOTAL LIABILITY FROM ANY AND ALL CAUSES SHALL BE LIMITED TO THE AMOUNT OF ONE HUNDRED US DOLLARS (\$100.00). EXPORT. Customer agrees that it will not directly or indirectly export the Evaluation Board to another country, and that it will comply with all applicable United States federal laws and regulations relating to exports. GOVERNING LAW. This Agreement shall be governed by and construed in accordance with the substantive laws of the Commonwealth of Massachusetts (excluding conflict of law rules). Any legal action regarding this Agreement will be heard in the state or federal courts having jurisdiction in Suffolk County, Massachusetts, and Customer hereby submits to the personal jurisdiction and venue of such courts. The United Nations Convention on Contracts for the International Sale of Goods shall not apply to this Agreement and is expressly disclaimed.

©2019 Analog Devices, Inc. All rights reserved. Trademarks and registered trademarks are the property of their respective owners.
UG20201-0-4/19(0)



www.analog.com

Looking for pricing, stock, or lifecycle information?

Click below to explore more details on WIN SOURCE:

 [View EVAL-ADAU1787Z on WIN SOURCE](#)

 [Analog Devices Inc. Information](#)

Optimize Your Supply Chain with WIN SOURCE Solutions

-  Global Sourcing Solution
-  Obsolete Management
-  Cost Control Management
-  Shortage Management
-  Alternative Solution
-  Excess Inventory Management