



**THE DATASHEET OF
IS31FL3205-QFLS4-TR**



12-CHANNEL LED DRIVER WITH 16-BIT PWM

May 2024

GENERAL DESCRIPTION

The IS31FL3205 is an LED driver with 12 constant current channels. Each channel can be pulse width modulated (PWM) by 16 bits for smooth LED brightness control. In addition, each channel has an 8-bit output current control register which allows fine tuning the current for rich RGB color mixing, e.g., a pure white color LED application. The maximum output current of each channel can be adjusted by one 8-bit global control register.

Proprietary programmable algorithms are used in IS31FL3205 to minimize audible noise caused by the MLCC decoupling capacitor. All registers can be programmed via a high speed I2C (1MHz).

IS31FL3205 can be turned off with minimum current consumption by either pulling the SDB pin low or by using the software shutdown feature.

IS31FL3205 is available in QFN-20 (3mm × 3mm) package. It operates from 2.7V to 5.5V over the temperature range of -40°C to +125°C.

FEATURES

- 2.7V to 5.5V supply
- Accuracy between channels and ICs: $\lt; \pm 6\%$ (Max.)
- 1MHz I2C interface, automatic address increment function with readout function
- Four selectable I2C addresses
- Accurate color rendition
 - Selectable 8-bit/10-bit/12-bit/16-bit PWM
 - 8-bit dot correction
 - 8-bit global current adjusted
- Open/Short detect function
- 62kHz PWM frequency (8-bit PWM)
- Temperature detect function
- EMI reduction technology
 - Spread spectrum
 - Selectable Phase Delay
 - Selectable 180 degree Clock Phase
- -40°C to +125°C temperature range
- QFN-20 (3mm×3mm) package
- RoHS & Halogen-Free Compliance
- TSCA Compliance

APPLICATIONS

- Hand-held devices for LED display
- AI-speakers and smart home devices
- LED in home appliances

TYPICAL APPLICATION CIRCUIT

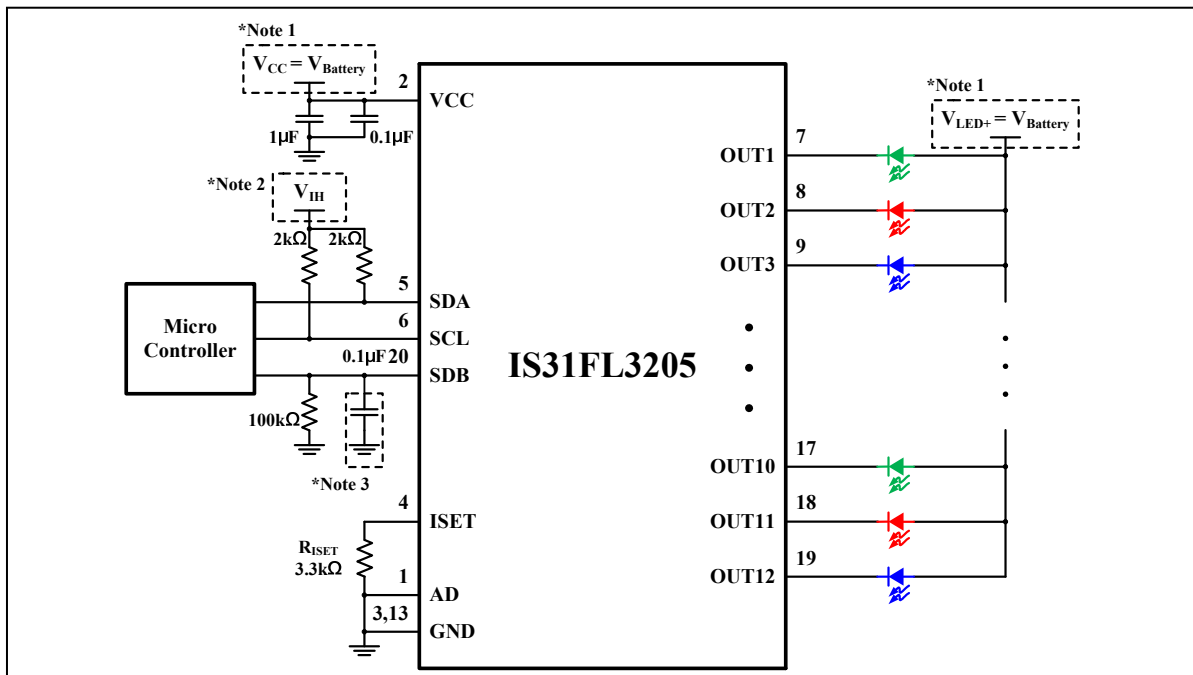

Figure 1 Typical Application Circuit

TYPICAL APPLICATION CIRCUIT (CONTINUED)

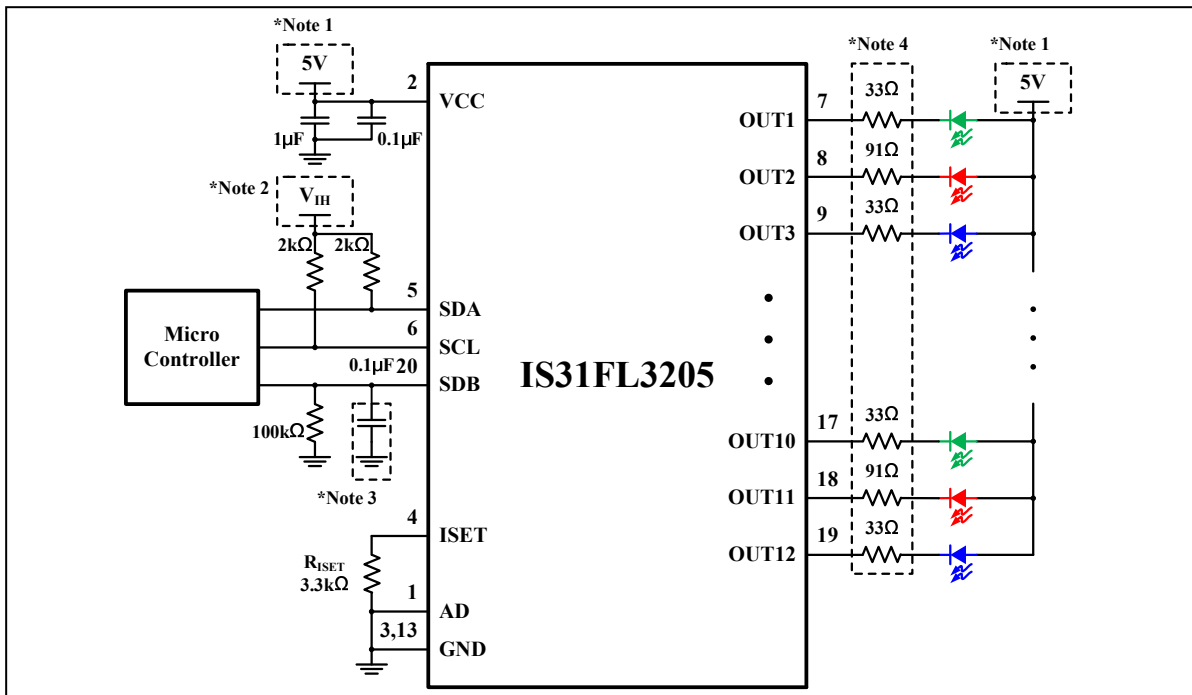

Figure 2 Typical Application Circuit ($V_{CC}=5V$)

Note 1: V_{LED+} can be higher than V_{CC} voltage, for example, $V_{LED+}=5V$, $V_{CC}=3.3V$.

Note 2: V_{IH} is the high level voltage for IS31FL3205, which is usually same as V_{CC} of Micro Controller, e.g. if V_{CC} of Micro Controller is 3.3V, $V_{IH}=3.3V$. If $V_{CC}=5V$ and V_{IH} is lower than 2.8V, recommend to add a level shift circuit for SDA and SCL.

Note 3: A 0.1µF capacitor is necessary for passing the EFT test.

Note 4: These optional resistors are for offloading the thermal dissipation ($P=I^2R$) away from the IS31FL3205.

Note 5: The maximum output current is set to 38.25mA when $R_{ISET}=2k\Omega$. Please refer to the detail application information in R_{ISET} section.

PIN CONFIGURATION

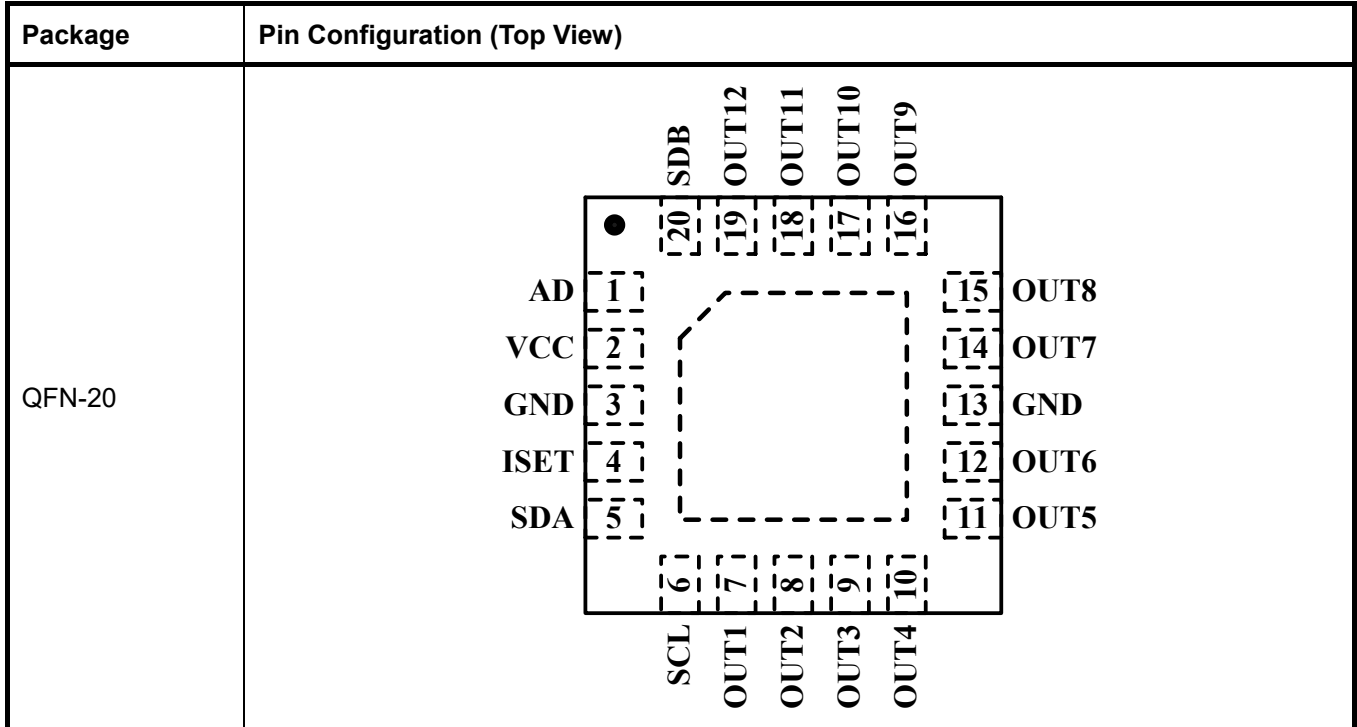

PIN DESCRIPTION

No.	Pin	Description
1	AD	I2C address setting.
2	VCC	Power supply.
3, 13	GND	Ground.
4	ISET	Input terminal used to connect an external resistor. This regulates the global output current.
5	SDA	I2C serial data.
6	SCL	I2C serial clock.
7~12	OUT1~OUT6	Output channel 1~6 for LEDs.
14~19	OUT7 ~ OUT12	Output channel 7~12 for LEDs.
20	SDB	Shutdown the chip when pulled low.
	Thermal Pad	Connect to GND.

IS31FL3205



ORDERING INFORMATION

Industrial Range: -40°C to +125°C

Order Part No.	Package	QTY/Reel
IS31FL3205-QFLS4-TR	QFN-20, Lead-free	2500

Copyright © 2024 Lumissil Microsystems. All rights reserved. Lumissil Microsystems reserves the right to make changes to this specification and its products at any time without notice. Lumissil Microsystems assumes no liability arising out of the application or use of any information, products or services described herein. Customers are advised to obtain the latest version of this device specification before relying on any published information and before placing orders for products.

Lumissil Microsystems does not recommend the use of any of its products in life support applications where the failure or malfunction of the product can reasonably be expected to cause failure of the life support system or to significantly affect its safety or effectiveness. Products are not authorized for use in such applications unless Lumissil Microsystems receives written assurance to its satisfaction, that:

- a.) the risk of injury or damage has been minimized;
- b.) the user assume all such risks; and
- c.) potential liability of Lumissil Microsystems is adequately protected under the circumstances

ABSOLUTE MAXIMUM RATINGS

Supply voltage, V_{CC} , OUT1 to OUT12	-0.3V ~ +6.0V
Voltage at SCL, SDA, SDB, AD	-0.3V ~ $V_{CC}+0.3V$
Maximum junction temperature, T_{JMAX}	+150°C
Storage temperature range, T_{STG}	-65°C ~ +150°C
Operating temperature range, $T_A=T_J$	-40°C ~ +125°C
Package thermal resistance (Mounted on JEDEC standard 4-layer (2s2p) PCB test board), θ_{JA}	58°C/W
ESD (HBM)	±7kV
ESD (CDM)	±750V

Note 6: Stresses beyond those listed under “Absolute Maximum Ratings” may cause permanent damage to the device. These are stress ratings only and functional operation of the device at these or any other condition beyond those indicated in the operational sections of the specifications is not implied. Exposure to absolute maximum rating conditions for extended periods may affect device reliability.

ELECTRICAL CHARACTERISTICS

Typical values are $T_A = 25^\circ\text{C}$, $V_{CC} = 5V$.

Symbol	Parameter	Condition	Min.	Typ.	Max.	Unit
V_{CC}	Supply voltage		2.7		5.5	V
I_{MAX}	Output current	$V_{CC}= 5V$, $V_{OUT}= 0.8V$, $R_{ISET}= 2k\Omega$, $GCC= 0xFF$, $Scaling= 0xFF$ (Note 7)		38		mA
I_{OUT}	Output current	$V_{CC}= 5V$, $V_{OUT}= 0.6V$, $R_{ISET}= 3.3k\Omega$, $GCC= 0xFF$, $SL= 0xFF$	21.39	23	24.61	mA
ΔI_{MAT}	Output current mismatch between channels	$R_{ISET}= 3.3k\Omega$, $GCC= 0xFF$, $V_{OUT}= 0.4V$, $SL= 0xFF$ (Note 8)	-6		6	%
V_{HR}	Headroom voltage	$GCC= 0xFF$, $R_{ISET}= 3.3k\Omega$, $I_{OUT}= 20mA$, $SL= 0xFF$		0.3	0.5	V
I_{CC}	Quiescent power supply current	$V_{CC}= 5V$, $R_{ISET}= 3.3k\Omega$, $GCC= 0xFF$, $SL= 0xFF$, $I_{OUT}= 23mA$, $PWM= 0x00$		3.3	5	mA
		$V_{CC}= 3.6V$, $R_{ISET}= 3.3k\Omega$, $GCC= 0xFF$, $SL= 0xFF$, $I_{OUT}= 23mA$, $PWM= 0x00$		2.7	4	mA
I_{SD}	Shutdown current	$V_{CC}= 5V$, $R_{ISET}= 3.3k\Omega$, $V_{SDB}= 0V$ or software shutdown		2	3	μA
		$V_{CC}= 3.6V$, $R_{ISET}= 3.3k\Omega$, $V_{SDB}= 0V$ or software shutdown		1	2	μA
f_{OUT}	PWM frequency of output	PWM resolution 8-bit, OSC clock 8MHz		32		kHz
I_{OZ}	Output leakage current	$V_{SDB}= 0V$ or software shutdown, $V_{OUT}= 5.5V$			0.1	μA
T_{SD}	Thermal shutdown	(Note 9)		160		°C
T_{SD_HY}	Thermal shutdown hysteresis	(Note 9)		13		°C
V_{ISET}	Output voltage of ISET pin			1.0		V

Logic Electrical Characteristics (SDA, SCL, SDB, AD)

V_{IL}	Logic “0” input voltage	$V_{CC}= 2.7V\sim 5.5V$			0.4	V
V_{IH}	Logic “1” input voltage	$V_{CC}= 2.7V\sim 5.5V$	1.4			V
I_{IL}	Logic “0” input current	$V_{INPUT}= 0V$ (Note 9)		5		nA
I_{IH}	Logic “1” input current	$V_{INPUT}= V_{CC}$ (Note 9)		5		nA

DIGITAL INPUT SWITCHING CHARACTERISTICS (NOTE 9)

Symbol	Parameter	Fast Mode			Fast Mode Plus			Units
		Min.	Typ.	Max.	Min.	Typ.	Max.	
f _{SCL}	Serial-clock frequency	-		400	-		1000	kHz
t _{BUF}	Bus free time between a STOP and a START condition	1.3		-	0.5		-	µs
t _{HD, STA}	Hold time (repeated) START condition	0.6		-	0.26		-	µs
t _{SU, STA}	Repeated START condition setup time	0.6		-	0.26		-	µs
t _{SU, STO}	STOP condition setup time	0.6		-	0.26		-	µs
t _{HD, DAT}	Data hold time (Note 10)	-		-	-		-	µs
t _{SU, DAT}	Data setup time (Note 11)	100		-	50		-	ns
t _{LOW}	SCL clock low period	1.3		-	0.5		-	µs
t _{HIGH}	SCL clock high period	0.7		-	0.26		-	µs
t _R	Rise time of both SDA and SCL signals, receiving	-		300	-		120	ns
t _F	Fall time of both SDA and SCL signals, receiving	-		300	-		120	ns

Note 7: The recommended minimum value of R_{ISET} is 2kΩ, or it may cause a large current.

Note 8: $\Delta I_{MAT} = (I_{OUT} - I_{AVG}) / I_{AVG} \times 100\%$. $I_{AVG} = (I_{OUT1} + I_{OUT2} + \dots + I_{OUT12}) / 12$.

Note 9: Guaranteed by design.

Note 10: The minimum t_{HD, DAT} measured start from V_{IL(Max.)} of SCL signal. The maximum t_{HD, DAT} has only to be met if the device does not stretch the LOW period (t_{LOW}) of the SCL signal. V_{IL(Max.)}

Note 11: A Fast-mode I2C-bus device can be used in a Standard-mode I2C-bus system, but the requirement t_{SU, DAT} ≥ 250ns must then be met. This will automatically be the case if the device does not stretch the LOW period of the SCL signal. If such a device does stretch the LOW period of the SCL signal, it must output the next data bit to the SDA line t_{R max} + t_{SU, DAT} = 1000 + 250 = 1250ns (according to the Standard-mode I2C-bus specification) before the SCL line is released.

FUNCTIONAL BLOCK DIAGRAM

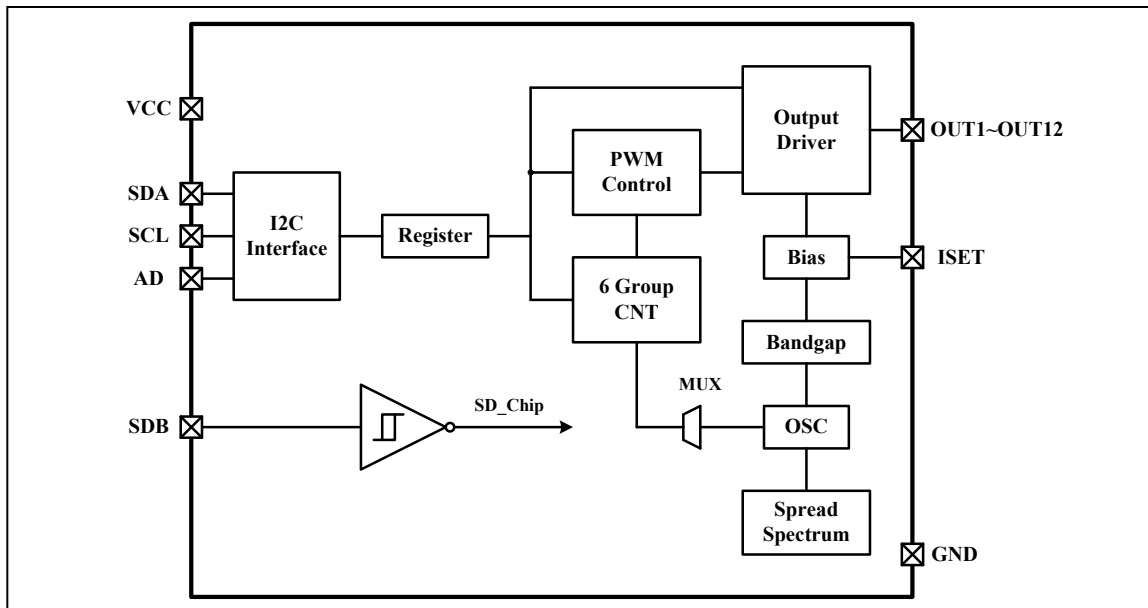

DETAILED DESCRIPTION

I2C INTERFACE

The IS31FL3205 uses a serial bus, which conforms to the I2C protocol, to control the chip's functions with two wires: SCL and SDA. The IS31FL3205 has a 7-bit slave address (A7:A1), followed by the R/W bit, A0. Set A0 to "0" for a write command and set A0 to "1" for a read command. The value of bits A1 and A2 are decided by the connection of the AD pin. The complete slave address is:

Table 1 Slave Address (Write Operation):

Bit	A7:A3	A2:A1	A0
Value	01101	AD	0

AD connected to GND, AD = 00;
 AD connected to VCC, AD = 11;
 AD connected to SCL, AD = 01;
 AD connected to SDA, AD = 10;

The SCL line is uni-directional. The SDA line is bi-directional (open-drian) with a pull-up resistor (typically 2kΩ). The maximum clock frequency specified by the I2C standard is 1MHz. In this discussion, the master is the microcontroller and the slave is the IS31FL3205.

The timing diagram for the I2C is shown in Figure 3. The SDA is latched in on the stable high level of the SCL. When there is no interface activity, the SDA line should be held high.

The "START" signal is generated by lowering the SDA signal while the SCL signal is high. The start signal will alert all devices attached to the I2C bus to check the incoming address against their own chip address.

The 8-bit chip address is sent next, most significant bit first. Each address bit must be stable while the SCL level is high.

After the last bit of the chip address is sent, the master checks for the IS31FL3205's acknowledge. The master releases the SDA line high (through a pull-up resistor).

Then the master sends an SCL pulse. If the IS31FL3205 has received the address correctly, then it holds the SDA line low during the SCL pulse. If the SDA line is not low, then the master should send a "STOP" signal (discussed later) and abort the transfer.

Following acknowledge of IS31FL3205, the register address byte is sent, most significant bit first. IS31FL3205 must generate another acknowledge indicating that the register address has been received.

Then 8-bit of data byte are sent next, most significant bit first. Each data bit should be valid while the SCL level is stable high. After the data byte is sent, the IS31FL3205 must generate another acknowledge to indicate that the data was received.

The "STOP" signal ends the transfer. To signal "STOP", the SDA signal goes high while the SCL signal is high.

ADDRESS AUTO INCREMENT

To write multiple bytes of data into IS31FL3205, load the address of the data register that the first data byte is intended for. During the IS31FL3205 acknowledge of receiving the data byte, the internal address pointer will increment by one. The next data byte sent to IS31FL3205 will be placed in the new address, and so on. The auto increment of the address will continue as long as data continues to be written to IS31FL3205 (Figure 6).

READING OPERATION

Most of the registers can be read.

To read the register, after I2C start condition, the bus master must send the IS31FL3205 device address with the R/W bit set to "0", followed by the register address which determines which register is accessed. Then restart I2C, the bus master should send the IS31FL3205 device address with the R/W bit set to "1". Data from the register defined by the command byte is then sent from the IS31FL3205 to the master (Figure 7).

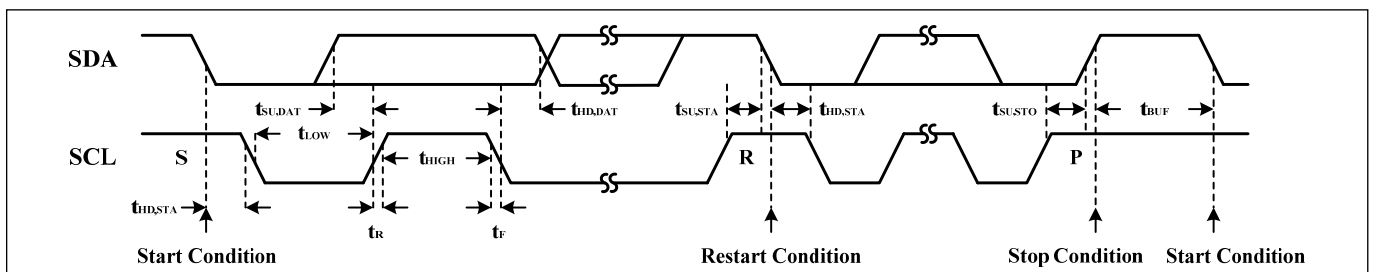

Figure 3 Interface Timing

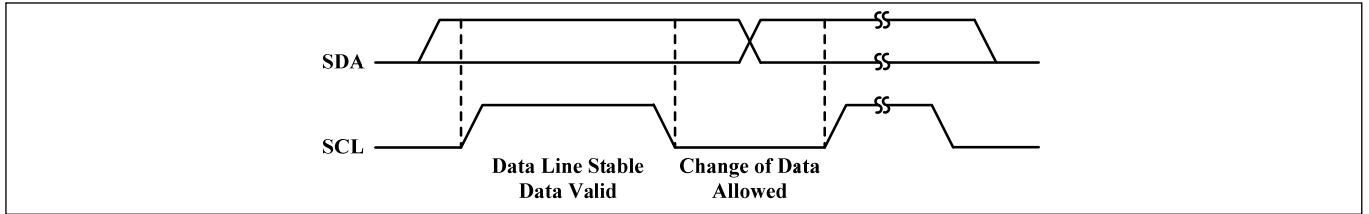

Figure 4 Bit Transfer

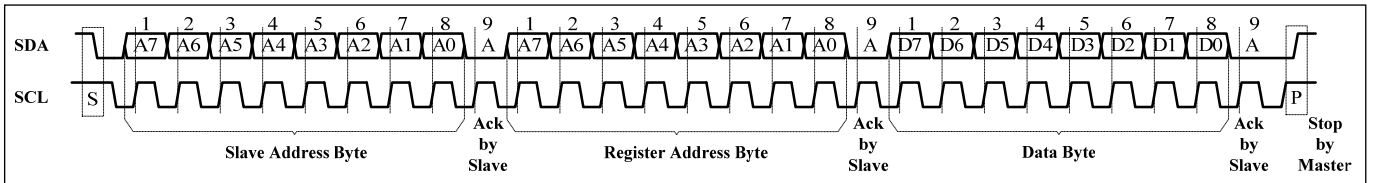

Figure 5 Writing to IS31FL3205 (Typical)

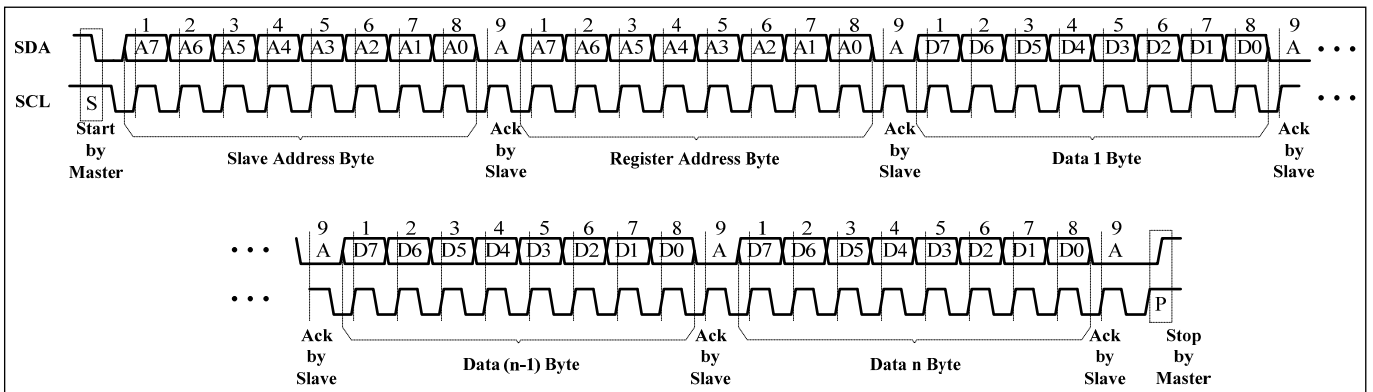

Figure 6 Writing to IS31FL3205 (Automatic Address Increment)

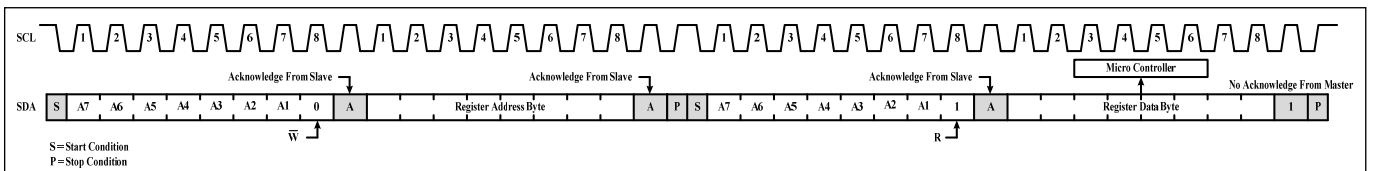

Figure 7 Reading from IS31FL3205

REGISTER DEFINITIONS

Table 2 Register Function

Address	Name	Function	R/W	Table	Default
00h	Control Register	Power control register	R/W	3	0000 0000
07h~1Eh	PWM Register	Channel [12:1] PWM register byte	R/W	5	
49h	Update Register	Update the PWM and Scaling data	W	-	
4Dh~58h	LED Scaling Register	Control each channel's DC current	R/W	7	
6Eh	Global Current Control Register	Control Global DC current/SSD	R/W	8	
70h	Phase Delay and Clock Phase Register	Phase Delay and Clock Phase	R/W	9	
71h	Open Short Detect Enable Register	Open short detect enable	R/W	10	
72h~73h	LED Open/Short Register	Open short information	R/W	11	
77h	Temperature Sensor Register	Temperature information	R/W	12	
78h	Spread Spectrum Register	Spread spectrum control register	R/W	13	
7Fh	Reset Register	Reset all registers	W	-	

Table 3 00h Control Register

Bit	D7	D6:D4	D3	D2:D1	D0
Name	-	OSC	-	PMS	SSD
Default	0	000	0	00	0

The Control Register sets software shutdown mode, internal oscillator clock frequency and PWM resolution. The internal oscillator clock frequency and the PWM resolution will decide the output PWM frequency. Recommend selecting PWM frequency higher than 20kHz to avoid MLCC audible noise as shown in Table 4.

SSD Software Shutdown Enable
 0 Software shutdown mode
 1 Normal operation

PMS PWM Resolution
 00 N=256, 8-bit
 01 N=1024, 10-bit
 10 N=4096, 12-bit
 11 N=65536, 16-bit

OSC Oscillator Clock Frequency Selection
 000 16MHz
 001 8MHz
 010 1MHz
 011 500kHz
 100 250kHz
 101 125kHz
 110 62kHz
 111 31kHz

Table 4 PWM Frequency

PWM Resolution	16M	8M	1M	500k	250k	125k	62k	31k
8bit	62k	32k	4k	2k	1k	0.5k	244	122
10bit	16k	8k	1k	0.5k	244	122	NA	NA
12bit	4k	2k	244	122	NA	NA	NA	NA
16bit	244	122	NA	NA	NA	NA	NA	NA

Table 5 07h~1Eh PWM Register

Reg	08h (0Ah, 0Ch...)	07h (09h, 0Bh...)
Bit	D7:D0	D7:D0
Name	PWM_H	PWM_L
Default	0000 0000	0000 0000

Each output has 2 bytes to modulate the PWM duty in 256/1024/4096/65536 steps. If using 8-bit PWM resolution, only PWM_L bits need to be set.

The value of the SL (Scaling Register) decides the peak current of each LED noted as I_{OUT} .

I_{OUT} and the value of the PWM Registers decide the average current of each LED noted as I_{LED} .

I_{OUT} is computed by Formula (1):

$$I_{OUT} = I_{OUT(MAX)} \times \frac{GCC}{256} \times \frac{SL}{256} \quad (1)$$

I_{LED} computed by Formula (2):

$$I_{LED} = \frac{PWM}{N} \times I_{OUT} \quad (2)$$

$$N=256: PWM = \sum_{n=0}^7 D[n] \cdot 2^n$$

$$N=1024: PWM = \sum_{n=0}^9 D[n] \cdot 2^n$$

$$N=4096: PWM = \sum_{n=0}^{11} D[n] \cdot 2^n$$

$$N=65536: PWM = \sum_{n=0}^{15} D[n] \cdot 2^n \quad (3)$$

Where $I_{OUT(MAX)}$ is the maximum output current decided by R_{ISET} (Check R_{ISET} section for more information), GCC is the global current setting (6Eh), and SL is the scaling of each output (4Ah~6Dh), N=256/1024/4096/65536 (8/10/12/16-bit PWM resolution).

For example: $R_{ISET}=3.3k\Omega$, $GCC=0xFF$, $SL=0xFF$, $PMS=“11”$ (16-bit PWM resolution), $PWM_H=0xFF$, $PWM_L=0xFF$, $I_{OUT(MAX)}=23.18mA$

$$I_{OUT} = I_{OUT(MAX)} \times \frac{255}{256} \times \frac{255}{256} = 23mA \quad (1)$$

$$PWM = \sum_{n=0}^{15} D[n] \cdot 2^n = 65535 \quad (3)$$

N= 65536

$$I_{LED} = \frac{65535}{65536} \times 23mA = 23mA \quad (2)$$

Where $I_{OUT(MAX)}$ is the maximum output current decided by R_{ISET} (Check R_{ISET} section for more information)

The I_{OUT} of each channel is set by the SL bits of LED Scaling Register (4Ah~6Dh). Please refer to the detail information in Table 7.

If $R_{ISET}=3.3k\Omega$, $GCC=0xFF$, $SL=0xFF$, $PMS=“00”$ (8-bit PWM resolution, only use the PWM_L , the PWM_H will be ignored), $PWM_H=0x77$, $PWM_L=0xAA$,

$I_{OUT(MAX)}=23.18mA$

$$I_{OUT} = I_{OUT(MAX)} \times \frac{255}{256} \times \frac{255}{256} = 23mA \quad (1)$$

$$PWM = \sum_{n=0}^7 D[n] \cdot 2^n = 170 \quad (3)$$

N= 256

$$I_{LED} = \frac{170}{256} \times 23mA \quad (2)$$

Table 6 PWM and Scaling Register Map

OUT	PWM		SL
	PWM_H	PWM_L	
1	08h	07h	4Dh
2	0Ah	09h	4Eh
3	0Ch	0Bh	4Fh
4	0Eh	0Dh	50h
5	10h	0Fh	51h
6	12h	11h	52h
7	14h	13h	53h
8	16h	15h	54h
9	18h	17h	55h
10	1Ah	19h	56h
11	1Ch	1Bh	57h
12	1Eh	1Dh	58h

49h Update Register

When SDB = “H” and SSD = “1”, a write of “0000 0000” to 49h is to update the PWM Registers (07h~1Eh) values.

Table 7 4Dh~58h LED Scaling Register

Bit	D7:D0
Name	SL
Default	0000 0000

Each output has 8 bits to modulate DC current in 256 steps.

The value of the LED Scaling Registers decides the DC peak current of each LED noted I_{OUT} .

I_{OUT} is computed by Formula (1):

$$I_{OUT} = I_{OUT(MAX)} \times \frac{GCC}{256} \times \frac{SL}{256} \quad (1)$$

$$SL = \sum_{n=0}^7 D[n] \cdot 2^n \quad (4)$$

Where $I_{OUT(MAX)}$ is the maximum output current decided by R_{ISET} , GCC is the global current setting (6Eh)

4Dh~58h don't need to update by 49h, each register will be updated immediately when it is written.

Table 8 6Eh Global Current Control Register

Bit	D7:D0
Name	GCC
Default	0000 0000

GCC and SL control the I_{OUT} as shown in Formula (1).

$$GCC = \sum_{n=0}^7 D[n] \cdot 2^n \quad (5)$$

If GCC=0xFF, SL=0xFF, $I_{OUT}=I_{OUT(MAX)}$

If GCC=0x01, SL=0xFF,

$$I_{OUT} = I_{OUT(MAX)} \times \frac{1}{256} \times \frac{255}{256}$$

Where $I_{OUT(MAX)}$ is the maximum output current decided by R_{ISET} (Check R_{ISET} section for more information).

Table 9 70h Phase Delay and Clock Phase Register

Bit	D7	D6:D3	D2	D1	D0
Name	PDE	-	PS3	PS2	PS1
Default	0	0000	0	0	0

IS31FL3205 features a 3 phases delay function, when PDE bit is set, the phase delay function is enabled.

Phase Delay separates 12 outputs as 3 groups, OUT1~OUT3 as group 1, OUT4~OUT9 as group 2, OUT10~OUT12 as group 3. When Phase Delay is enabled, group 2 has a $1/(3 \times f_{OUT})$ time delay than group 1, group 3 also has a $1/(3 \times f_{OUT})$ time delay than group 2.

Phase Delay feature and Clock Phase options can work together to minimize the voltage ripple of LED power supply.

PDE Group Phase Delay Enable
 0 Phase delay disable
 1 Phase delay enable

PS1 OUT1~OUT3 Phase Select
 0 Phase delay 0 Degree
 1 Phase delay 180 Degree

PS2 OUT4~OUT9 Phase Select
 0 Phase delay 0 Degree
 1 Phase delay 180 Degree

PS3 OUT10~OUT12 Phase Select
 0 Phase delay 0 Degree
 1 Phase delay 180 Degree

Table 10 71h Open Short Detect Enable Register

Bit	D7:D2	D1:D0
Name	-	OSDE
Default	0000 00	00

OSDE enables the open and/or short LED channel detection with the result stored in 72h~76h, note either open or short information is saved not both.

OSDE Open Detect Enable
 00 Detect disable
 01 Detect disable
 10 Short detect enable
 11 Open detect enable

Table 11-1 72h LED Open/Short Register

Bit	D7:D3	D2:D0
Name	OP/ST[5:1]	-
Default	0000 0	xxx

Table 11-2 73h LED Open/Short Register

Bit	D7	D6:D0
Name	-	OP/ST[12:6]
Default	x	000 0000

Open or short status is stored in 72h to 73h.

OP[12:1] Open Information of OUT12:OUT1
 0 Open not detected
 1 Open detected

ST[12:1] Short Information of OUT12:OUT1
 0 Short not detected
 1 Short detected

Table 12 77h Temperature Sensor Register

Bit	D7:D6	D5	D4	D3:D2	D1:D0
Name	TROF	-	T_Flag	-	TS
Default	00	0	0	00	00

TS stores the temperature/thermal roll-off point. TROF stores percentage of output current of the thermal roll-off function.

Read T_Flag can indicate if the die temperature exceeds the setting point (TS). Before each reading of 77h register, TROF and TS need to be re-written.

TROF Thermal roll off percentage of output current
 00 100%
 01 75%
 10 55%
 11 30%

T_Flag	Temperature Flag
0	Temperature point not exceeded
1	Temperature point exceeded
TS	Temperature Point, Thermal roll off start point
00	140°C
01	120°C
10	100°C
11	90°C

Table 13 78h Spread Spectrum Register

Bit	D7:D5	D4	D3:D2	D1:D0
Name	DCPWM	SSP	RNG	CLT
Default	000	0	00	00

When DCPWM is set to “0”, the PWM outputs are decided by 01h~1Eh, and the PWM range is 0/256~255/256(8-bit PWM, 0/1024~1023/1024 for 10 bit PWM, 0/4096~4095/4096 for 12 bit PWM, 0/65536~65535/65536 for 16 bit PWM), still the 1/256(8-bit PWM, 1/1024 for 10 bit PWM, 1/4096 for 12 bit PWM, 1/65536 for 16 bit PWM), can’t be turned on. When the DCPWM is set to “1”, PWM dimming is disabled and dimming will be done by current adjust GCC and SL registers.

Spread spectrum register configures the spread spectrum function, adjust the cycle time and range.

DCPWM	Setting the output to work in DC mode
xx0	Output 1~9 PWM data set by registers 01h~18h
xx1	Output 1~9 set to turn on (PWM is disabled)
x0x	Output 10~12 PWM data set by registers 19h~1Eh
x1x	Output 10~12 set to turn on (PWM is disabled)

SSP	Spread Spectrum Enable
0	Disable
1	Enable

RNG	Spread Spectrum Range
00	±5%
01	±15%
10	±24%
11	±34%

CLT	Spread Spectrum Cycle Time
00	1980µs
01	1200µs
10	820µs
11	660µs

7Fh Reset Register

When SDB = “H” and SSD = “1”, A write of “0000 0000” to 7Fh will reset all registers to their default values.

APPLICATION INFORMATION

R_{ISET}

The maximum output current I_{OUT(MAX)} of OUT1~OUT12 can be adjusted by the external resistor, R_{ISET}, as described in Formula (6).

$$I_{OUT(MAX)} = x \cdot \frac{V_{ISET}}{R_{ISET}} \quad (6)$$

x = 76.5, V_{ISET} = 1.0V.

The recommended minimum value of R_{ISET} is 2kΩ.

When R_{ISET}=3.3kΩ, I_{OUT(MAX)}=23.18mA

When R_{ISET}=2kΩ, I_{OUT(MAX)}=38.25mA

R_{ISET} should be close to the chip and the ground side should well connect to the GND plane.

CURRENT SETTING

The maximum output current is set by the external register R_{ISET}. The current of each output can also be set independently by the SL 8 bits of LED Scaling Register (4Dh~58h).

Some applications may require the IOUT of each channel need to be adjusted independently. For example, if OUT1 drives 1 LED and OUT2 drives 2 parallel LEDs, and they should have the same average current like 18mA, we can set the I_{OUT(MAX)} to 36mA, and GCC=0xFF, 4Ah=0x80, 4Bh=0xFF, the OUT1 sinks about 18mA and OUT2 sinks 36mA which can have two LEDs in parallel.

Another example, OUT1, OUT2 and OUT3 drive an RGB LED, OUT1 is Red LED, OUT2 is Green LED and OUT 3 is Blue LED, with same R_{ISET}, GCC and same SL bits, when OUT1 OUT2 and OUT3 have the same PWM value, the LED may look a litter pink, or not so white, in this case, the SL bits can be used to adjust the single IOUTx of some output and make it pure white color. We call this SL bits another name: white balance registers.

PWM CONTROL

The PWM Registers (07h~1Eh) can modulate LED brightness of each 12 channels with 256/1024/4096/65536 steps. For example, if the data in PWM_H Register is "0000 0000" and in PWM_L Register is "0000 0100", then the PWM is the fourth step.

Writing new data continuously to the registers can modulate the brightness of the LEDs to achieve a breathing effect.

PWM FREQUENCY SELECT

The IS31FL3205 output channels operate with a default 8-bit PWM resolution and the PWM frequency of 62kHz (the oscillator frequency is 16MHz).

Because all the OUTx channels are synchronized, the DC power supply will experience large instantaneous current surges when the OUTx channels turn ON. These current surges will generate an AC ripple on the power supply which cause stress to the decoupling capacitors. When the AC ripple is applied to a monolithic ceramic capacitor chip (MLCC) it will expand and contract causing the PCB to flex and generate audible hum in the range of between 300Hz to 18kHz, To avoid this hum, there are many countermeasures, such as selecting the capacitor type and value which will not cause the PCB to flex and contract.

An additional option for avoiding audible hum is to set the IS31FL3205's output PWM frequency above/below the audible range. The Control Register (00h) can be used to set the switching frequency to 122Hz~62kHz as shown in Table 4, some combine setting of the OSC and PMS bits will get different output PWM frequency, and higher than 20kHz or is out of the audible range.

OPEN/SHORT DETECT FUNCTION

IS31FL3205 has open and short detect bit for each LED.

By setting the OSDE bit of Open Short Detect Enable Register (71h) from "00" to "10" (store short information) or "11" (store open information), the LED Open/Short Register will store the open/short information immediately the MCU can get the open/short information by reading the 72h~73h.

SPREAD SPECTRUM FUNCTION

PWM current switching of LED outputs can be particularly troublesome when the EMI is concerned. To optimize the EMI performance, the IS31FL3205 includes a spread spectrum function. By setting the RNG bit of Spread Spectrum Register (78h), Spread Spectrum range can be chosen from ±5% /±15% /±24% /±34%. The spread spectrum function will lower the total electromagnetic emitting energy by spreading the energy into a wider range to significantly degrade the peak energy of EMI. With spread spectrum, the EMI test is easier to pass with a smaller size and lower cost filter circuit.

OPERATING MODE

IS31FL3205 can only operate in PWM Mode. The brightness of each LED can be modulated with 256/1024/4096/65536 steps by PWM registers. For example, if the data in PWM Register is "0000 0100", then the PWM is the fourth step.

Writing new data continuously to the registers can modulate the brightness of the LEDs to achieve a breathing effect.

SHUTDOWN MODE

Shutdown mode can be used as a means of reducing power consumption. During shutdown mode all registers retain their data.

Software Shutdown

By setting the SSD bit of the Control Register (00h) to "0", the IS31FL3205 will operate in software shutdown mode. When the IS31FL3205 is in software shutdown, all current sources are switched off, so the LEDs are OFF but all registers accessible. Typical current consume is $1\mu\text{A}$ ($V_{CC}=3.6\text{V}$).

Hardware Shutdown

The chip enters hardware shutdown when the SDB pin is pulled low. All analog circuits are disabled during hardware shutdown, typical the current consumption is $1\mu\text{A}$ ($V_{CC}=3.6\text{V}$).

The chip releases hardware shutdown when the SDB pin is pulled high. The rising edge of SDB pin will reset the I2C module, but the register information retains. During hardware shutdown the registers are accessible.

If the VCC supply drops below 1.75V but remains above 0.1V during SDB pulled low, please re-initialize all Function Registers before SDB pulled high.

LAYOUT

The IS31FL3205 consumes lots of power so good PCB layout will help improve the reliability of the chip. Please consider below factors when layout the PCB.

Power Supply Lines

When designing the PCB layout pattern, the first step should consider about the supply line and GND connection, especially those traces with high current,

also the digital and analog blocks' supply line and GND should be separated to avoid the noise from digital block affect the analog block.

At least one $0.1\mu\text{F}$ capacitor, if possible with a $1\mu\text{F}$ capacitor is recommended to connected to the ground at power supply pin of the chip, and it needs to close to the chip and the ground net of the capacitor should be well connected to the GND plane.

R_{ISSET}

R_{ISSET} should be close to the chip and the ground side should well connect to the GND plane.

Thermal Consideration

The over temperature of the chip may result in deterioration of the properties of the chip. The thermal pad of IS31FL3205 should connect to GND net and need to use 4 or 9 vias connect to GND copper area, the GND area should be as large area as possible to help radiate the heat from the IS31FL3205.

Current Rating Example

For a R_{ISSET}=3.3k Ω application, the current rating for each net is as follows:

- VCC pin maximum current is 5mA when $V_{CC}=5\text{V}$, but the VLED+ net provides total current of all outputs, its current can as much as $23\text{mA}\times 12=276\text{mA}$, recommend trace width for VCC pin: 0.20mm~0.3mm, recommend trace width for VLED+ net: 0.25mm~0.4mm,
- Output pins=23mA, recommend trace width is 0.2mm~0.254mm
- All other pins<3mA, recommend trace width is 0.15mm~0.254mm

CLASSIFICATION REFLOW PROFILES

Profile Feature	Pb-Free Assembly
Preheat & Soak Temperature min (T _{smin}) Temperature max (T _{smax}) Time (T _{smin} to T _{smax}) (t _s)	150°C 200°C 60-120 seconds
Average ramp-up rate (T _{smax} to T _p)	3°C/second max.
Liquidous temperature (T _L) Time at liquidous (t _L)	217°C 60-150 seconds
Peak package body temperature (T _p)*	Max 260°C
Time (t _p)** within 5°C of the specified classification temperature (T _c)	Max 30 seconds
Average ramp-down rate (T _p to T _{smax})	6°C/second max.
Time 25°C to peak temperature	8 minutes max.

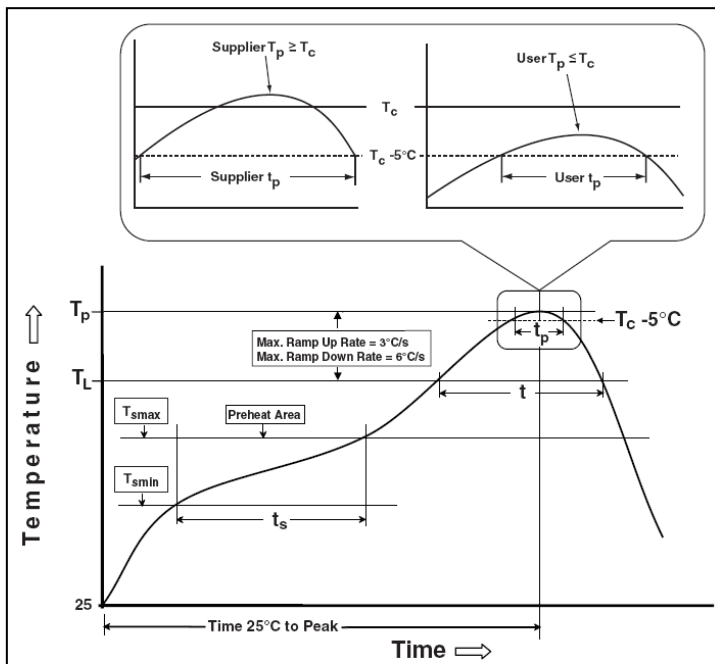
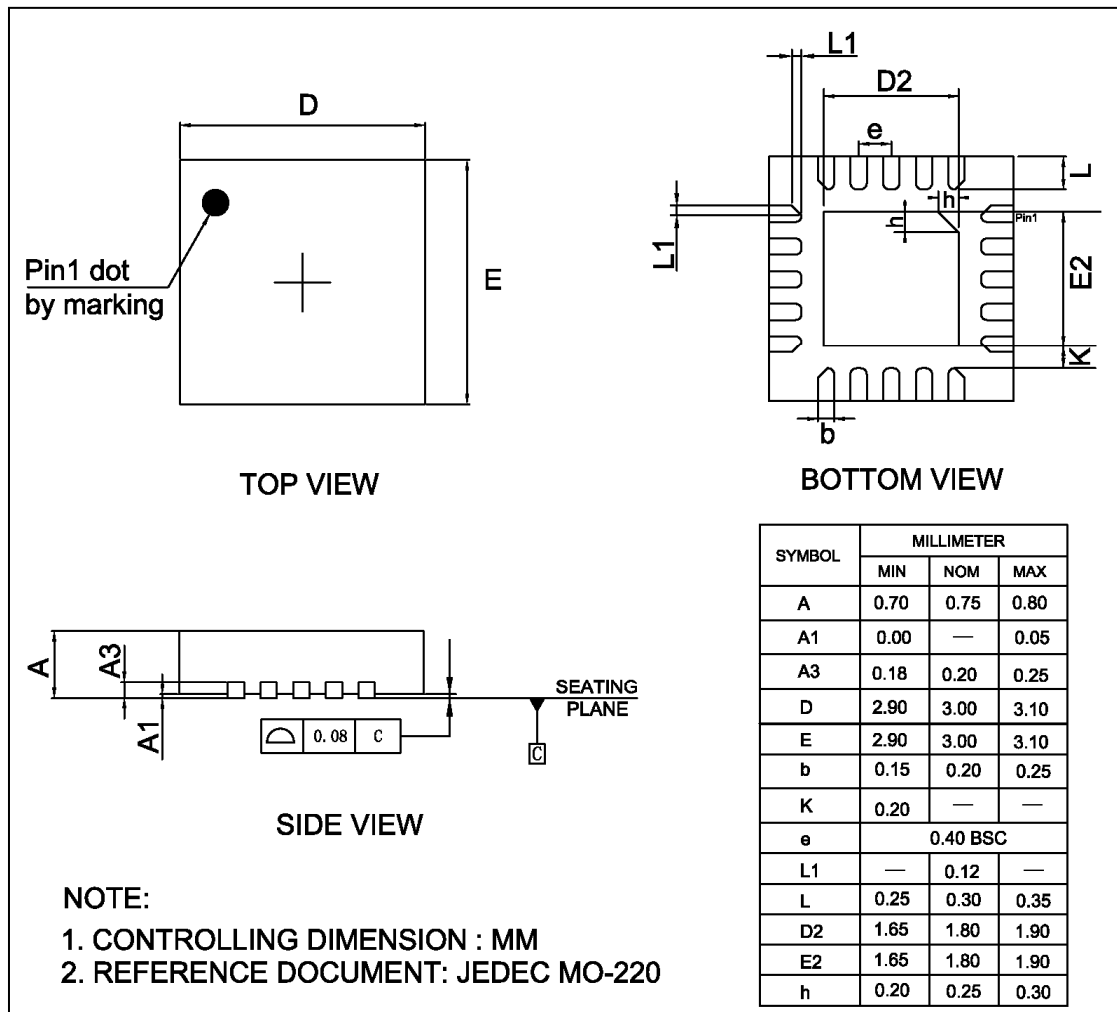

Figure 8 Classification Profile

IS31FL3205

PACKAGE INFORMATION

QFN-20



RECOMMENDED LAND PATTERN

QFN-20

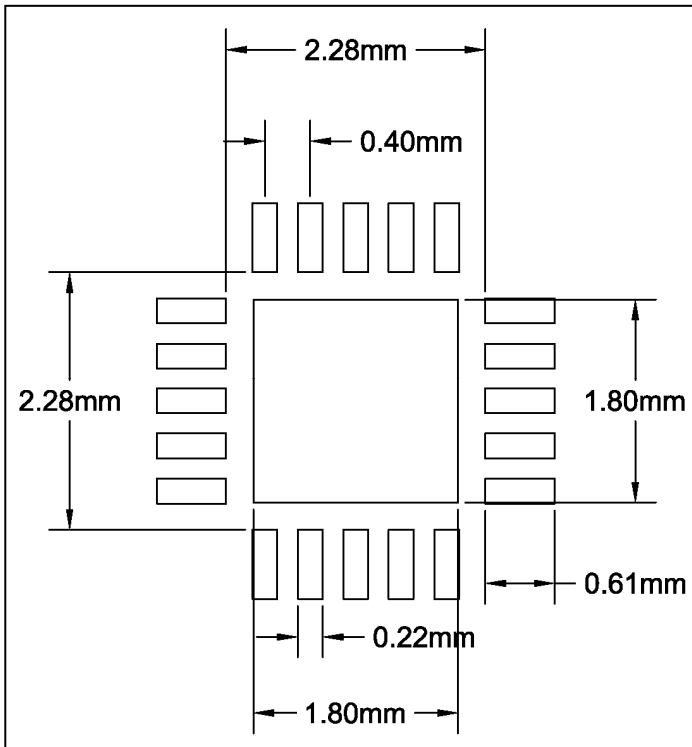

Note:

1. Land pattern complies to IPC-7351.
2. All dimensions in MM.
3. This document (including dimensions, notes & specs) is a recommendation based on typical circuit board manufacturing parameters. Since land pattern design depends on many factors unknown (eg. user's board manufacturing specs), user must determine suitability for use.

REVISION HISTORY

Revision	Detail Information	Date
A	Initial release.	2020.02.27
B	Update note 1 and correct OUT1-OUT12 ABSOLUTE MAXIMUM RATINGS	2021.12.27
C	Update to new Lumissil logo	2024.05.14

Looking for pricing, stock, or lifecycle information?

Click below to explore more details on WIN SOURCE:

- [View IS31FL3205-QFLS4-TR on WIN SOURCE](#)
- [Lumissil Microsystems Information](#)

Optimize Your Supply Chain with WIN SOURCE Solutions

- ✓ Global Sourcing Solution
- ✓ Obsolete Management
- ✓ Cost Control Management
- ✓ Shortage Management
- ✓ Alternative Solution
- ✓ Excess Inventory Management