



**THE DATASHEET OF
IS31FL3743A-QULS4-TR**



IS31FL3743A

18 × 11 DOTS MATRIX LED DRIVER

April 2022

GENERAL DESCRIPTION

The IS31FL3743A is a general purpose 18×n (n=1~11) LED Matrix programmed via 1MHz I2C compatible interface. Each LED can be dimmed individually with 8-bit PWM data and 8-bit DC scaling data which allowing 256 steps of linear PWM dimming and 256 steps of DC current adjustable level.

Additionally each LED open and short state can be detected, IS31FL3743A store the open or short information in Open-Short Registers. The Open-Short Registers allowing MCU to read out via I2C compatible interface, inform MCU whether there are LEDs open or short and the locations of open or short LEDs.

The IS31FL3743A operates from 2.7V to 5.5V and features a very low shutdown and operational current.

IS31FL3743A is available in UQFN-40 (5mm×5mm) package. It operates from 2.7V to 5.5V over the temperature range of -40°C to +125°C.

FEATURES

- Supply voltage range: 2.7V to 5.5V
- 18 current sinks
- Support 18×n (n=1~11) LED matrix configurations
- Individual 256 PWM control steps
- Individual 256 DC current steps
- Global 256 DC current steps
- SDB rising edge reset I2C module
- Programmable H/L logic: 1.4V/0.4V, 2.4V/0.6V
- 24kHz PWM frequency
- 1MHz I2C-compatible interface
- State lookup registers
- Individual open and short error detect function
- 180 degree phase delay operation to reduce power noise
- De-Ghost
- Cascade for synchronization of chips
- UQFN-40 (5mm×5mm) package

APPLICATIONS

- Hand-held devices for LED display
- Gaming device (Keyboard, Mouse etc.)
- LED in white goods application

TYPICAL APPLICATION CIRCUIT

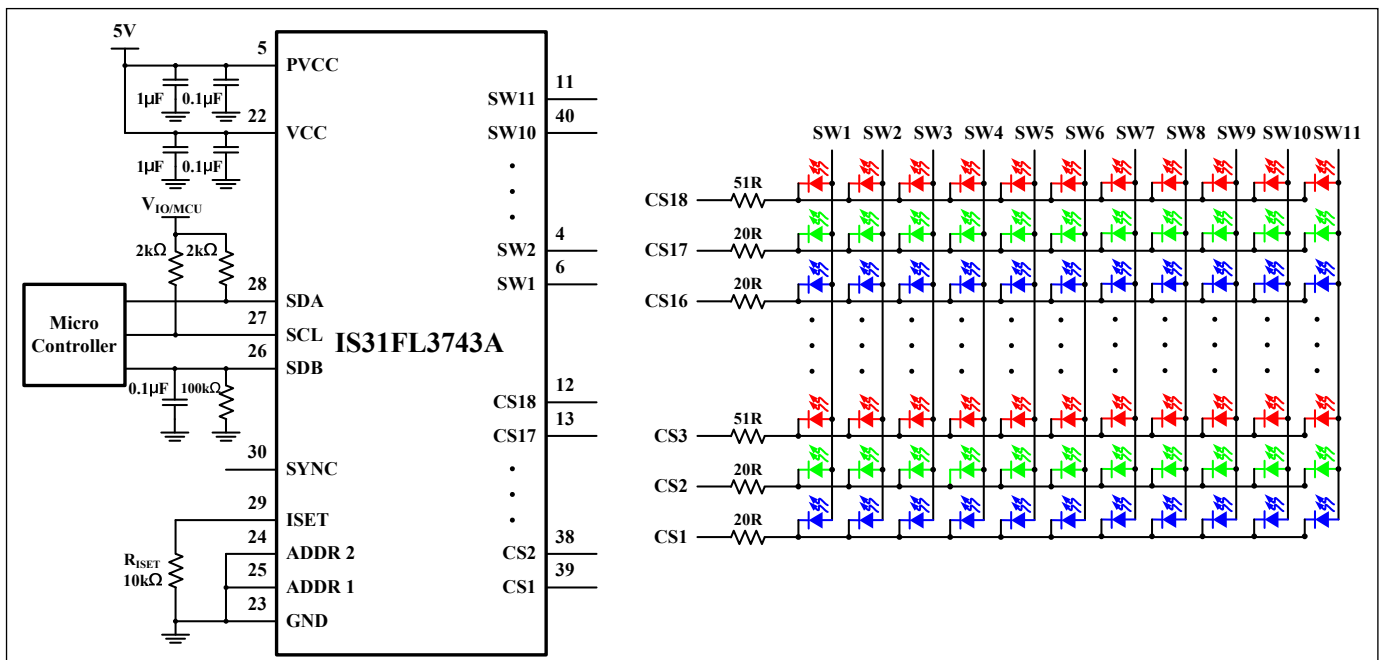

Figure 1 Typical Application Circuit: 66 RGBs

Note 1: For the mobile applications the IC should be placed far away from the mobile antenna in order to prevent the EMI.

Note 2: PVCC and VCC should use same power supply to avoid the additional I_{SD} , it is OK to use $PV_{CC}=V_{CC}=5V$ and $V_{IO}=3.3V$.

IS31FL3743A

TYPICAL APPLICATION CIRCUIT (CONTINUED)

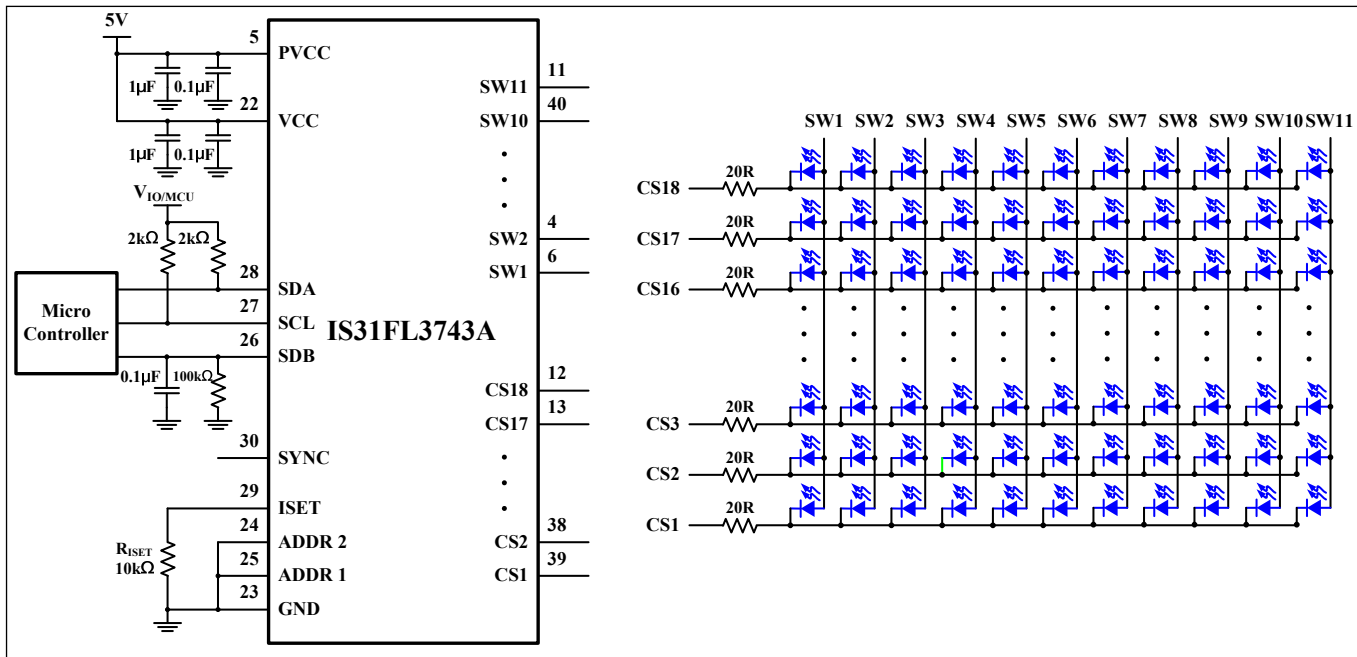

Figure 2 Typical Application Circuit: 198 Mono Color LEDs

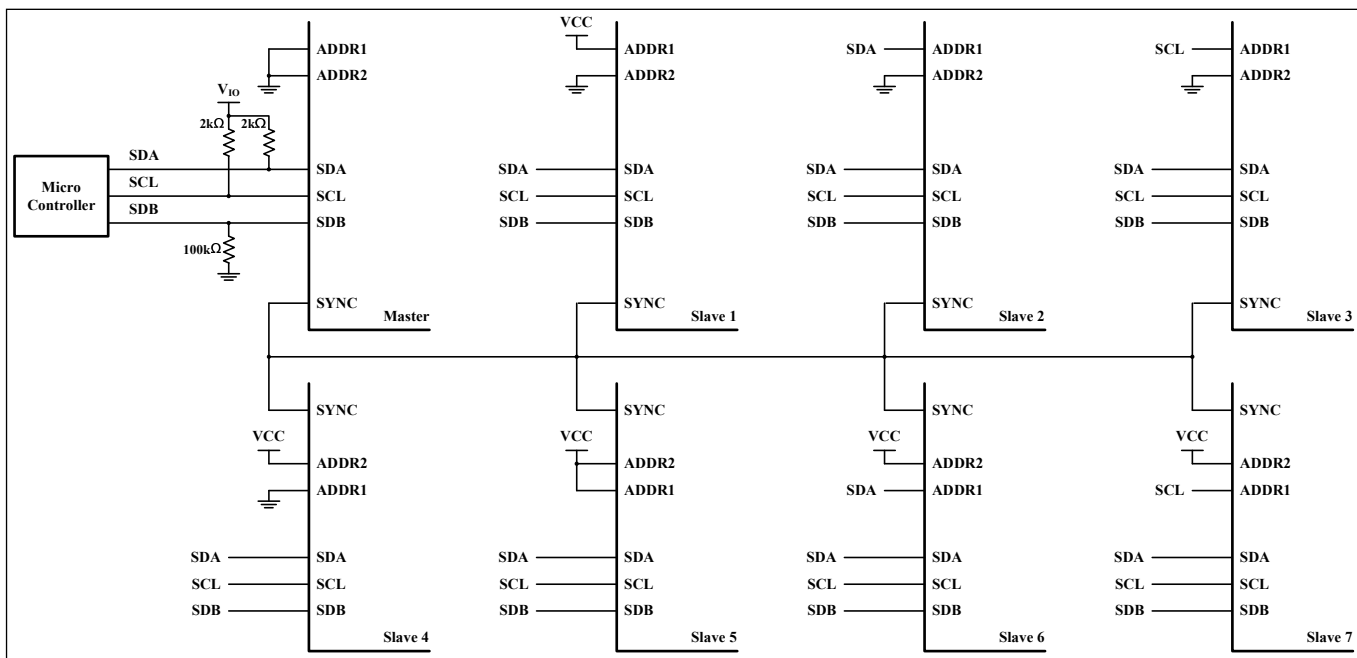

Figure 3 Typical Application Circuit (Eight Parts Synchronization-Work)

Note 3: The 20R and 50R between LED and IC is only for thermal reduction, for mono red LED, if $PV_{CC}=V_{CC}=3.3V$, don't need these resistors.

Note 4: One part is configured as master mode, all the other 7 parts configured as slave mode. Work as master mode or slave mode specified by Configuration Register (SYNC bits, register 25h, Page 2). Master part output master clock, and all the other parts which work as slave input this master clock.

IS31FL3743A

PIN CONFIGURATION

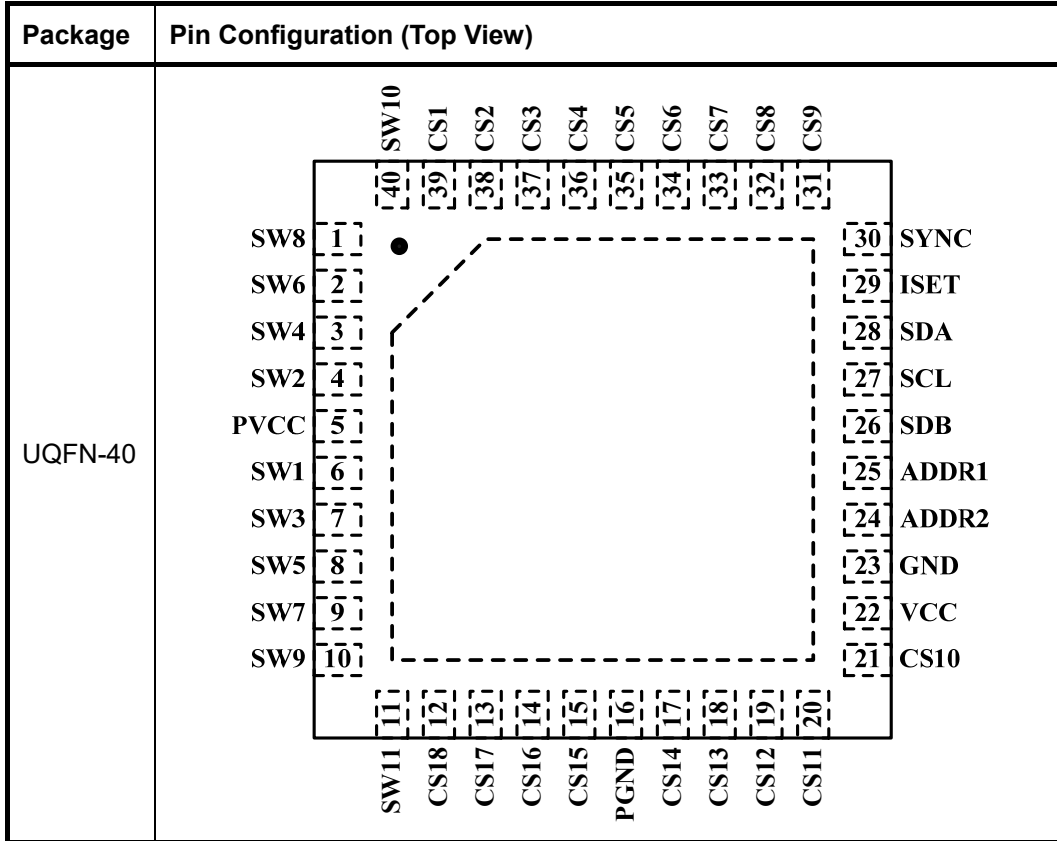

PIN DESCRIPTION

No.	Pin	Description
1~4	SW8,SW6,SW4,SW2	Power SW.
5	PVCC	Power for current source SW.
6~11	SW1,SW3,SW5,SW7,SW9,SW11	Power SW.
12~15	CS18~CS15	Current sink pin for LED matrix.
16	PGND	Power GND.
17~21	CS14~CS10	Current sink pin for LED matrix.
22	VCC	Analog and digital circuits.
23	GND	Analog GND.
24	ADDR2	I2C address select pin 2.
25	ADDR1	I2C address select pin 1.
26	SDB	Shutdown pin.
27	SCL	I2C compatible serial clock.
28	SDA	I2C compatible serial data.
29	ISET	Set the maximum IOOUT current.
30	SYNC	Synchronization.
31~39	CS9~CS1	Current sink pin for LED matrix.
40	SW10	Power SW.
	Thermal Pad	Connect to GND.

IS31FL3743A

ORDERING INFORMATION

Industrial Range: -40°C to +125°C

Order Part No.	Package	QTY/Reel
IS31FL3743A-QULS4-TR	UQFN-40, Lead-free	2500

Copyright © 2022 Lumissil Microsystems. All rights reserved. Lumissil Microsystems reserves the right to make changes to this specification and its products at any time without notice. Lumissil Microsystems assumes no liability arising out of the application or use of any information, products or services described herein. Customers are advised to obtain the latest version of this device specification before relying on any published information and before placing orders for products.

Lumissil Microsystems does not recommend the use of any of its products in life support applications where the failure or malfunction of the product can reasonably be expected to cause failure of the life support system or to significantly affect its safety or effectiveness. Products are not authorized for use in such applications unless Lumissil Microsystems receives written assurance to its satisfaction, that:

- a.) the risk of injury or damage has been minimized;
- b.) the user assume all such risks; and
- c.) potential liability of Lumissil Microsystems is adequately protected under the circumstances

IS31FL3743A

ABSOLUTE MAXIMUM RATINGS

Supply voltage, V_{CC}	-0.3V ~+6.0V
Voltage at any input pin	-0.3V ~ $V_{CC}+0.3V$
Maximum junction temperature, T_{JMAX}	+150°C
Storage temperature range, T_{STG}	-65°C ~+150°C
Operating temperature range, $T_A=T_J$	-40°C ~ +125°C
Package thermal resistance, junction to ambient (4-layer standard test PCB based on JESD 51-2A), θ_{JA}	41.6°C/W
ESD (HBM)	±7kV
ESD (CDM)	±1kV

Note 5: Stresses beyond those listed under “Absolute Maximum Ratings” may cause permanent damage to the device. These are stress ratings only and functional operation of the device at these or any other condition beyond those indicated in the operational sections of the specifications is not implied. Exposure to absolute maximum rating conditions for extended periods may affect device reliability.

ELECTRICAL CHARACTERISTICS

The following specifications apply for $V_{CC} = 3.6V$, $T_A = 25^\circ C$, unless otherwise noted.

Symbol	Parameter	Conditions	Min.	Typ.	Max.	Unit
V_{CC}	Supply voltage		2.7		5.5	V
I_{CC}	Quiescent power supply current	$V_{SDB}=V_{CC}$, all LEDs off		1.8		mA
I_{SD}	Shutdown current	$V_{SDB}=0V$		1.3		μA
		$V_{SDB}=V_{CC}$, Configuration Register written “0000 0000”		1.3		
I_{OUT}	Maximum constant current of CSy	$R_{ISET}=10k\Omega$, $GCC=0xFF$ $SL=0xFF$	32.09	34.5	36.91	mA
I_{LED}	Average current on each LED $I_{LED} = I_{OUT(PEAK)}/Duty (11.275)$	$R_{ISET}=10k\Omega$, $GCC=0xFF$ $SL=0xFF$		3.03		mA
V_{HR}	Current switch headroom voltage SWx	$I_{SWITCH}=612mA$, $R_{ISET}=10k\Omega$, $GCC=0xFF$, $SL=0xFF$		550		mV
	Current sink headroom voltage CSy	$I_{SINK}=34mA$, $R_{ISET}=10k\Omega$, $GCC=0xFF$, $SL=0xFF$		450		
t_{SCAN}	Period of scanning			33		μs
t_{NOL1}	Non-overlap blanking time during scan, the SWx and CSy are all off during this time			0.83		μs
t_{NOL2}	Delay total time for CS1 to CS18, during this time, the SWx is on but CSy is not all turned on			0.3		μs

Logic Electrical Characteristics (SDA, SCL, ADDR_x, SDB)

V_{IL}	Logic “0” input voltage	$V_{CC}=2.7V\sim 5.5V$, $LGC=0$			0.4	V
V_{IH}	Logic “1” input voltage	$V_{CC}=2.7V\sim 5.5V$, $LGC=0$	1.4			V
V_{HYS}	Input schmitt trigger hysteresis	$V_{CC}=3.6V$, $LGC=0$		0.2		V
V_{IL}	Logic “0” input voltage	$V_{CC}=2.7V\sim 5.5V$, $LGC=1$			0.6	V
V_{IH}	Logic “1” input voltage	$V_{CC}=2.7V\sim 5.5V$, $LGC=1$	2.4			V
V_{HYS}	Input schmitt trigger hysteresis	$V_{CC}=3.6V$, $LGC=1$		0.2		V
I_{IL}	Logic “0” input current	$SDB=L$, $V_{INPUT} = L$ (Note 6)		5		nA
I_{IH}	Logic “1” input current	$SDB=L$, $V_{INPUT} = H$ (Note 6)		5		nA

IS31FL3743A

DIGITAL INPUT I2C SWITCHING CHARACTERISTICS (NOTE 6)

Symbol	Parameter	Fast Mode			Fast Mode Plus			Units
		Min.	Typ.	Max.	Min.	Typ.	Max.	
f_{SCL}	Serial-clock frequency	-		400	-		1000	kHz
t_{BUF}	Bus free time between a STOP and a START condition	1.3		-	0.5		-	μ s
$t_{HD, STA}$	Hold time (repeated) START condition	0.6		-	0.26		-	μ s
$t_{SU, STA}$	Repeated START condition setup time	0.6		-	0.26		-	μ s
$t_{SU, STO}$	STOP condition setup time	0.6		-	0.26		-	μ s
$t_{HD, DAT}$	Data hold time	-		-	-		-	μ s
$t_{SU, DAT}$	Data setup time	100		-	50		-	ns
t_{LOW}	SCL clock low period	1.3		-	0.5		-	μ s
t_{HIGH}	SCL clock high period	0.7		-	0.26		-	μ s
t_R	Rise time of both SDA and SCL signals, receiving	-		300	-		120	ns
t_F	Fall time of both SDA and SCL signals, receiving	-		300	-		120	ns

Note 6: Guaranteed by design.

IS31FL3743A

FUNCTIONAL BLOCK DIAGRAM

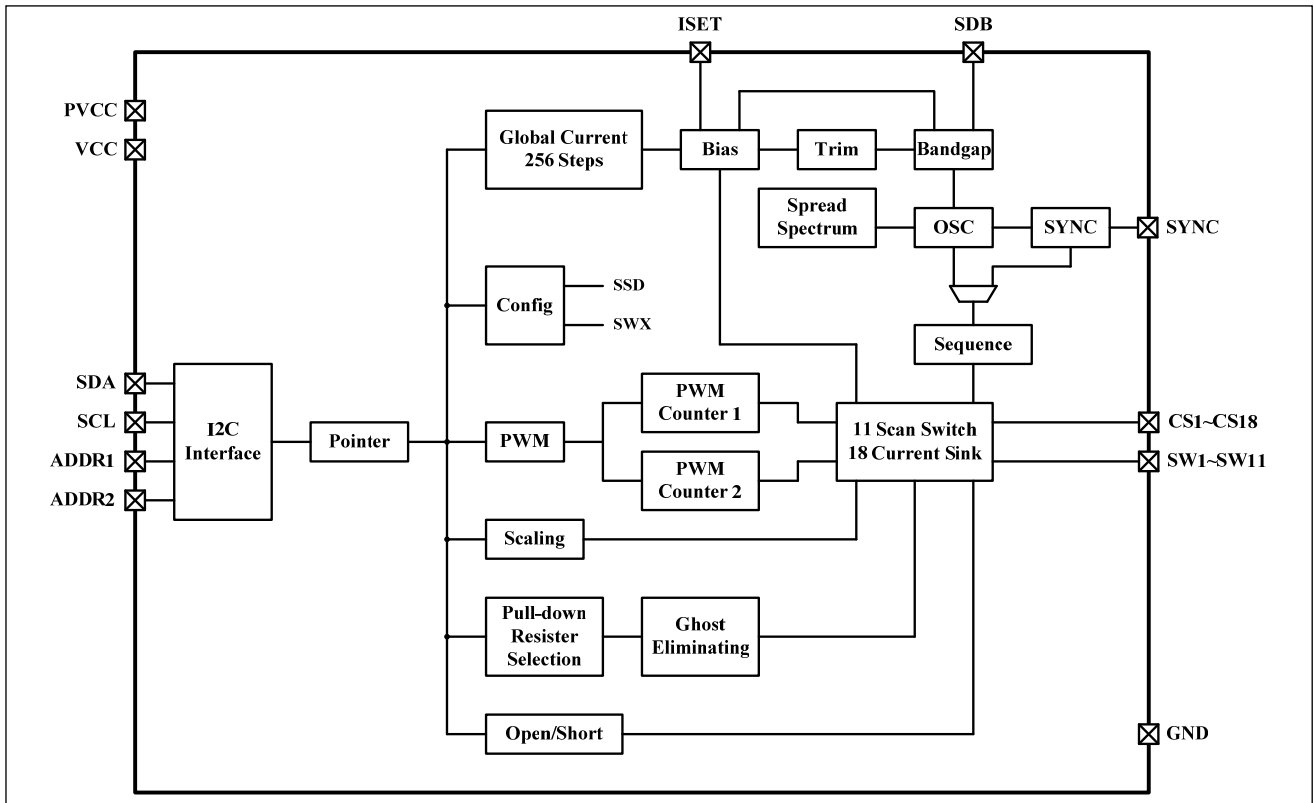

IS31FL3743A

DETAILED DESCRIPTION

I2C INTERFACE

IS31FL3743A uses a serial bus, which conforms to the I2C protocol, to control the chip's functions with two wires: SCL and SDA. The IS31FL3743A has a 7-bit slave address (A7:A1), followed by the R/W bit, A0. Set A0 to "0" for a write command and set A0 to "1" for a read command. The value of bits A1 and A2 are decided by the connection of the ADDR_x pin.

Table 1 Slave Address:

ADDR2	ADDR1	A7:A5	A4:A3	A2:A1	A0
GND	GND	010	00	00	0/1
GND	SCL		00	01	
GND	SDA		00	10	
GND	VCC		00	11	
SCL	GND		01	00	
SCL	SCL		01	01	
SCL	SDA		01	10	
SCL	VCC		01	11	
SDA	GND		10	00	
SDA	SCL		10	01	
SDA	SDA		10	10	
SDA	VCC		10	11	
VCC	GND		11	00	
VCC	SCL		11	01	
VCC	SDA		11	10	
VCC	VCC		11	11	

ADDR1/2 connected to GND, (A2:A1)/(A4:A3)=00;
 ADDR1/2 connected to VCC, (A2:A1)/(A4:A3)=11;
 ADDR1/2 connected to SCL, (A2:A1)/(A4:A3)=01;
 ADDR1/2 connected to SDA, (A2:A1)/(A4:A3)=10;

The SCL line is uni-directional. The SDA line is bi-directional (open-drain) with a pull-up resistor (typically 400kHz I2C with 4.7kΩ, 1MHz I2C with 2kΩ). The maximum clock frequency specified by the I2C standard is 1MHz. In this discussion, the master is the microcontroller and the slave is the IS31FL3743A.

The timing diagram for the I2C is shown in Figure 4. The SDA is latched in on the stable high level of the SCL. When there is no interface activity, the SDA line should be held high.

The "START" signal is generated by lowering the SDA signal while the SCL signal is high. The start signal will alert all devices attached to the I2C bus to check the incoming address against their own chip address.

The 8-bit chip address is sent next, most significant bit first. Each address bit must be stable while the SCL level is high.

After the last bit of the chip address is sent, the master checks for the IS31FL3743A's acknowledge. The master releases the SDA line high (through a pull-up resistor). Then the master sends an SCL pulse. If the IS31FL3743A has received the address correctly, then it holds the SDA line low during the SCL pulse. If the SDA line is not low, then the master should send a "STOP" signal (discussed later) and abort the transfer.

Following acknowledge of IS31FL3743A, the register address byte is sent, most significant bit first. IS31FL3743A must generate another acknowledge indicating that the register address has been received.

Then 8-bit of data byte are sent next, most significant bit first. Each data bit should be valid while the SCL level is stable high. After the data byte is sent, the IS31FL3743A must generate another acknowledge to indicate that the data was received.

The "STOP" signal ends the transfer. To signal "STOP", the SDA signal goes high while the SCL signal is high.

ADDRESS AUTO INCREMENT

To write multiple bytes of data into IS31FL3743A, load the address of the data register that the first data byte is intended for. During the IS31FL3743A acknowledge of receiving the data byte, the internal address pointer will increment by one. The next data byte sent to IS31FL3743A will be placed in the new address, and so on. The auto increment of the address will continue as long as data continues to be written to IS31FL3743A (Figure 7).

READING OPERATION

Most of the registers can be read.

To read the FCh, FEh, after I2C start condition, the bus master must send the IS31FL3743A device address with the R/W bit set to "0", followed by the register address (FEh or F1h) which determines which register is accessed. Then restart I2C, the bus master should send the IS31FL3743A device address with the R/W bit set to "1". Data from the register defined by the command byte is then sent from the IS31FL3743A to the master (Figure 8).

To read the registers of Page 0 thru Page 3, the FDh should write with 00h before follow the Figure 8 sequence to read the data. That means, when you want to read registers of Page 0, the FDh should point to Page 0 first and you can read the Page 0 data.

IS31FL3743A

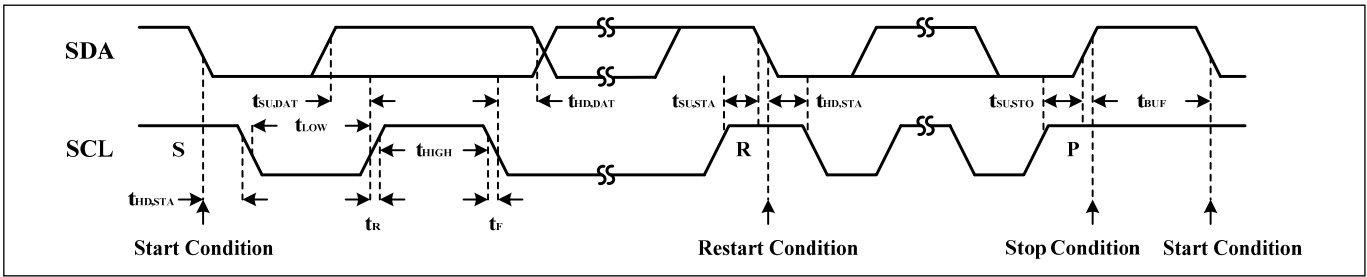

Figure 4 I2C Interface Timing

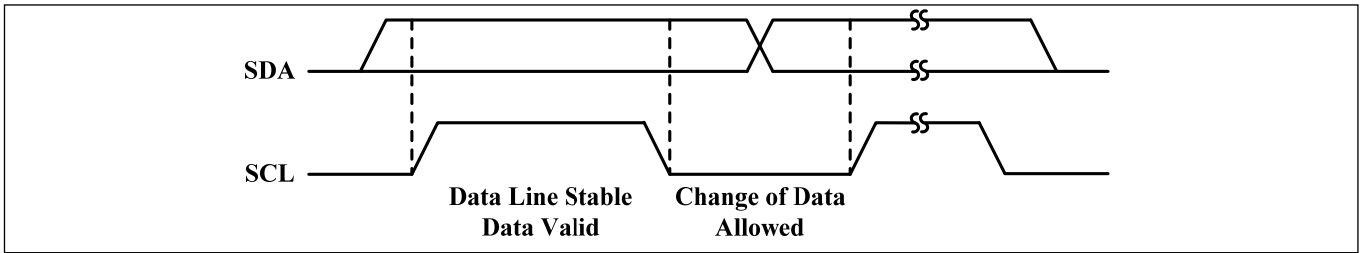

Figure 5 I2C Bit Transfer

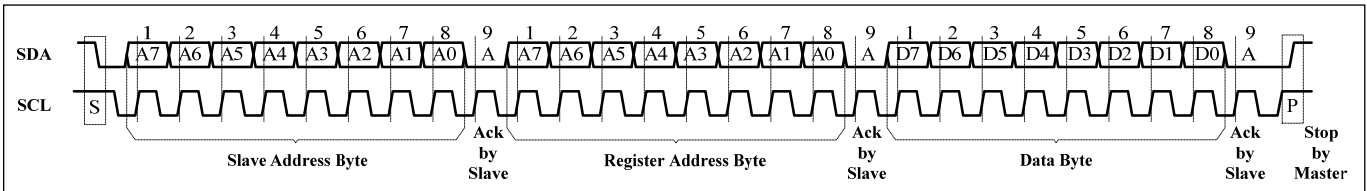

Figure 6 I2C Writing to IS31FL3743A (Typical)

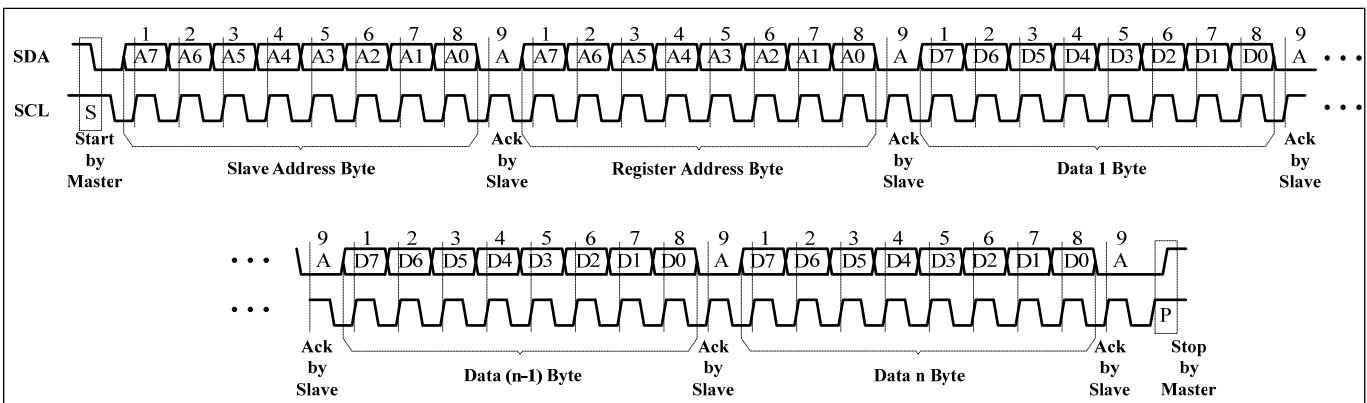

Figure 7 I2C Writing to IS31FL3743A (Automatic Address Increment)

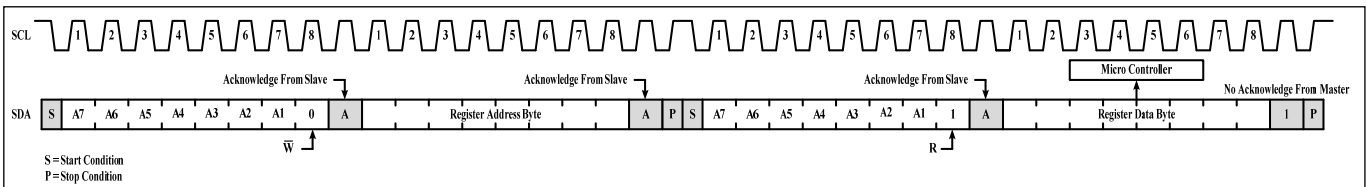

Figure 8 I2C Reading from IS31FL3743A

IS31FL3743A

Table 2 Command Register Definition

Address	Name	Function	Table	R/W	Default
FEh	Command Register Write Lock	To unlock Command Register	4	R/W	0000 0000
FDh	Command Register	Available Page 0 to Page 2 Registers	3	W	xxxx xxxx
FCh	ID Register	For read the product ID only Read result is the slave address	-	R	Slave Address

REGISTER CONTROL

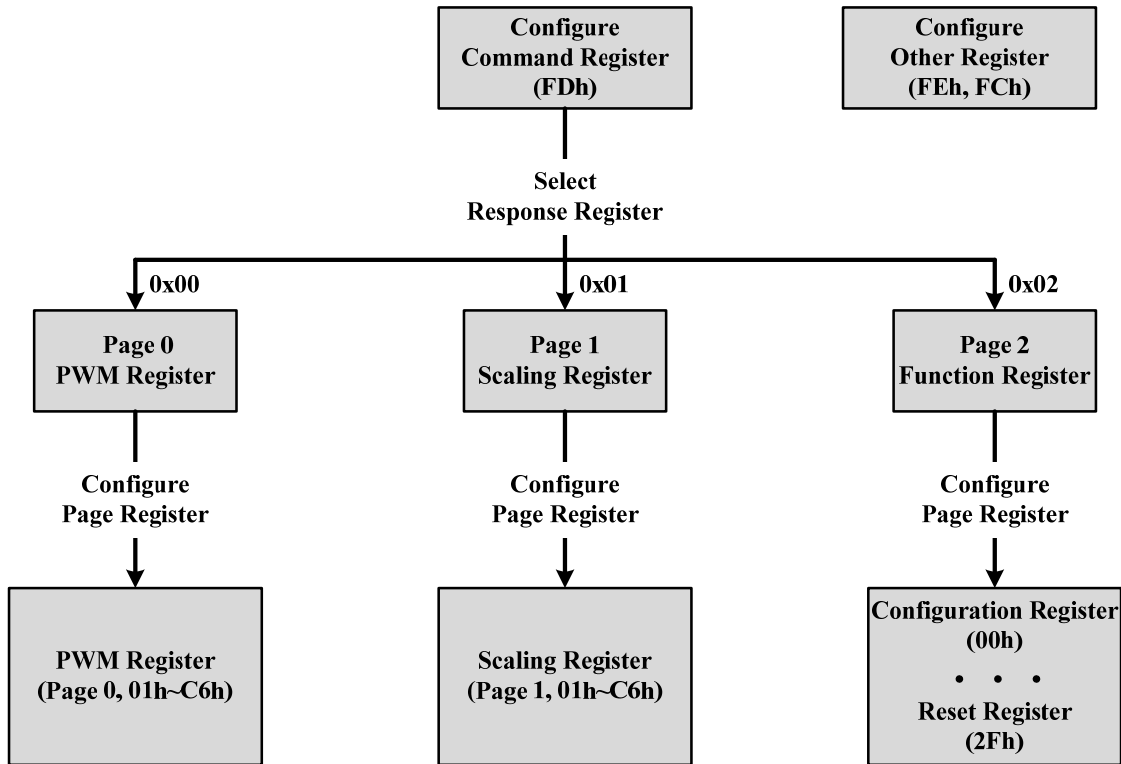

Table 3 FDh Command Register

Data	Function
0000 0000	Point to Page 0 (PG0, PWM Register is available)
0000 0001	Point to Page 1 (PG1, White balance Scaling Register is available)
0000 0010	Point to Page 2 (PG2, Function Register is available)
Others	Reserved

Note: FDh is locked when power up, need to unlock this register before write command to it. See Table 4 for detail.

The Command Register should be configured first after writing in the slave address to choose the available register. Then write data in the choosing register. Power up default state is "0000 0000".

For example, when write "0000 0001" in the Command Register (FDh), the data which writing after will be stored in the White balance Scaling Register. Write new data can configure other registers.

IS31FL3743A

Table 4 FEh Command Register Write Lock (Read/Write)

Bit	D7:D0
Name	CRWL
Default	0000 0000 (FDh write disable)

To select the PG0~PG2, need to unlock this register first, with the purpose to avoid mis-operation of this register. When FEh is written with 0xC5, FDh is allowed to modify once, after the FDh is modified the FEh will reset to be 0x00 at once.

Table 5 Register Definition

Address	Name	Function	Table	R/W	Default
PG0 (0x00): PWM Register					
01h~C6h	PWM Register	Set PWM for each LED	6	R/W	0000 0000
PG1 (0x01): LED Scaling					
01h~C6h	Scaling Register	Set Scaling for each LED	7	R/W	0000 0000
PG2 (0x02): Function Register					
00h	Configuration Register	Configure the operation mode	9	R/W	0000 0000
01h	Global Current Control Register	Set the global current	10	R/W	0000 0000
02h	Pull Down/Up Resistor Selection Register	Set the pull-down resistor for SWx and pull up resistor for CSy	11	R/W	0011 0011
03h~23h	Open/Short Register	Store the open or short information	12	R	0000 0000
24h	Temperature Status	Store the temperature point of the IC	13	R/W	0000 0000
25h	Spread Spectrum Register	Spread spectrum function enable	14	R/W	0000 0000
2Fh	Reset Register	Reset all register to POR state	-	W	0000 0000

IS31FL3743A

Page 0 (PG0, FDh= 0x00): PWM Register

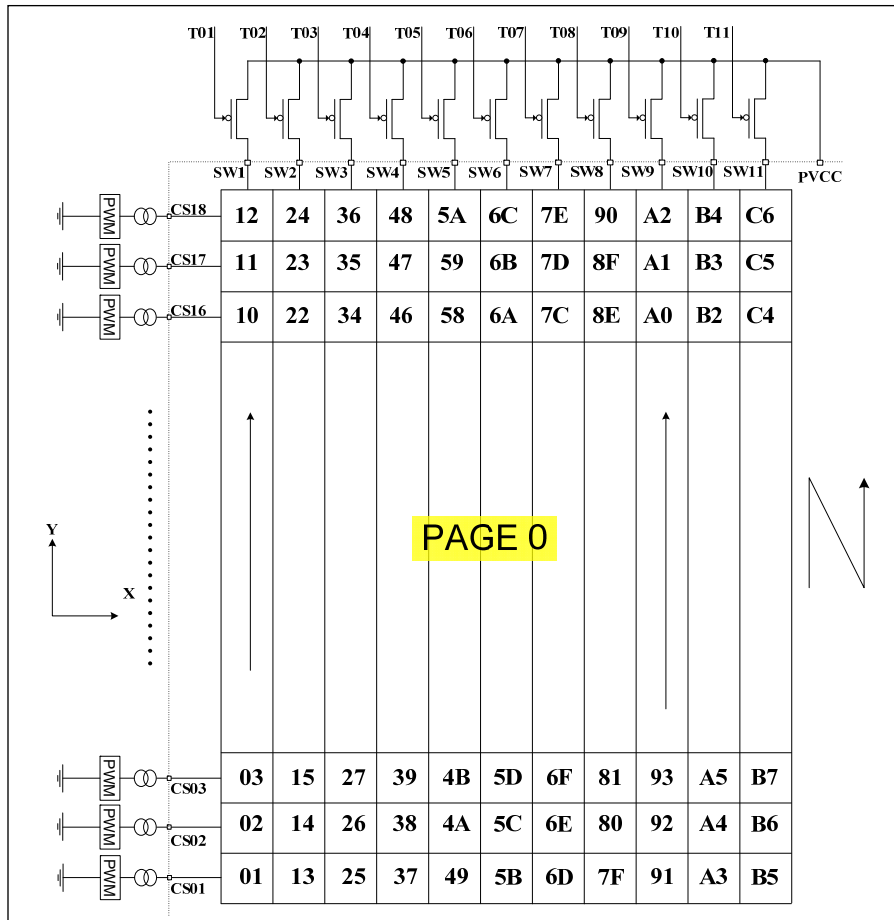

Figure 9 PWM Register

Table 6 PG0: 01h ~ C6h PWM Register

Bit	D7:D0
Name	PWM
Default	0000 0000

Each dot has a byte to modulate the PWM duty in 256 steps.

The value of the PWM Registers decides the average current of each LED noted I_{LED} .

I_{LED} computed by Formula (1):

$$I_{LED} = \frac{PWM}{256} \times I_{OUT(PEAK)} \times Duty \quad (1)$$

$$PWM = \sum_{n=0}^7 D[n] \cdot 2^n$$

Where Duty is the duty cycle of SWx, see SCANNING TIMING section for more information.

$$Duty = \frac{33\mu s}{(33\mu s + 0.83\mu s + 0.3\mu s)} \times \frac{1}{11} = \frac{1}{11.377} \quad (2)$$

I_{OUT} is the output current of CSy (y=1~18),

$$I_{OUT(PEAK)} = \frac{343}{R_{ISET}} \times \frac{GCC}{256} \times \frac{SL}{256} \quad (3)$$

GCC is the Global Current Control register (PG2, 01h) value, SL is the Scaling Register value as Table 9 and R_{ISET} is the external resistor of ISET pin. D[n] stands for the individual bit value, 1 or 0, in location n.

For example: if D7:D0=1011 0101 (0xB5, 181), GCC=1111 1111, R_{ISET} =10kΩ, SL=1111 1111:

$$I_{LED} = \frac{343}{10\text{ k}\Omega} \times \frac{255}{256} \times \frac{255}{256} \times \frac{1}{11.377} \times \frac{181}{256}$$

IS31FL3743A

Page 1 (PG1, FDh= 0x01): Scaling Register

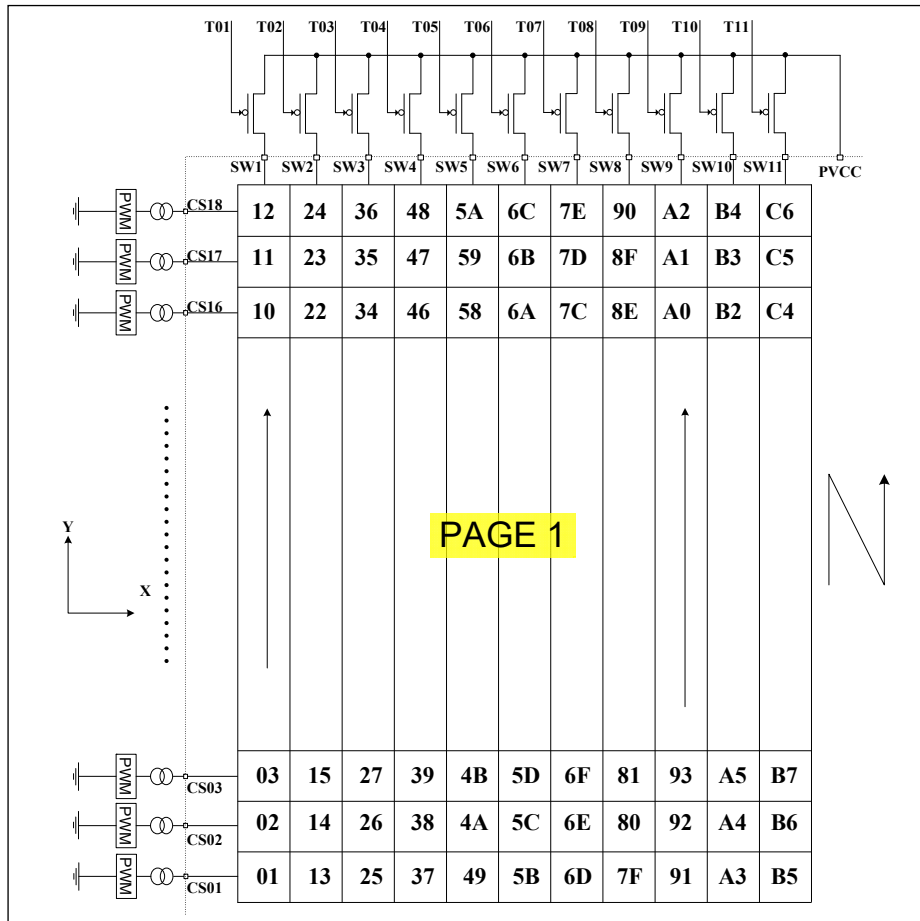

Figure 10 Scaling Register

Table 7 PG1: 01h ~ C6h Scaling Register

Bit	D7:D0
Name	SL
Default	0000 0000

Scaling register control the DC output current of each dot. Each dot has a byte to modulate the scaling in 256 steps.

The value of the Scaling Register decides the peak current of each LED noted $I_{OUT(PEAK)}$.

$I_{OUT(PEAK)}$ computed by Formula (3):

$$I_{OUT(PEAK)} = \frac{343}{R_{ISET}} \times \frac{GCC}{256} \times \frac{SL}{256} \quad (3)$$

$$SL = \sum_{n=0}^7 D[n] \cdot 2^n$$

I_{OUT} is the output current of CS_y (y=1~18), GCC is the Global Current Control Register (PG2, 01h) value and R_{ISET} is the external resistor of ISET pin. D[n] stands for the individual bit value, 1 or 0, in location n.

For example: if $R_{ISET}=10k\Omega$, GCC=1111 1111, SL=0111 1111:

$$SL = \sum_{n=0}^7 D[n] \cdot 2^n = 127$$

$$I_{OUT} = \frac{343}{10k\Omega} \times \frac{255}{256} \times \frac{127}{256} = 16.8mA$$

$$I_{LED} = 16.8mA \times \frac{1}{11.377} \times \frac{PWM}{256}$$

IS31FL3743A

Table 8 Page 2 (PG2, FDh= 0x02): Function Register

Register	Name	Function	Table	R/W	Default
00h	Configuration Register	Configure the operation mode	10	R/W	0000 1000
01h	Global Current Control Register	Set the global current	11	R/W	0000 0000
02h	Pull Down/Up Resistor Selection Register	Set the pull-down resistor for SWx and pull up resistor for CSy	12	R/W	0011 0011
03h~23h	Open/Short Register	Store the open or short information	13	R	0000 0000
24h	Temperature Status	Store the temperature point of the IC	14	R/W	0000 0000
25h	Spread Spectrum Register	Spread spectrum function enable	15	R/W	0000 0000
2Fh	Reset Register	Reset all register to POR state	-	W	0000 0000

Table 9 00h Configuration Register

Bit	D7:D4	D3	D2:D1	D0
Name	SWS	LGC	OSDE	SSD
Default	0000	1	00	0

The Configuration Register sets operating mode of IS31FL3743A.

When OSDE set to “01”, open detection will be trigger once, the user could trigger open detection again by set OSDE from “00” to “01”.

Before set OSDE, the GCC should set to 0x0F, please check OPEN/SHORT DETECT FUNCTION section for more information.

When SSD is “0”, IS31FL3743A works in software shutdown mode and to normal operate the SSD bit should set to “1”. SWS control the duty cycle of the SW, default mode is 1/11.

SSD Software Shutdown Control
 0 Software shutdown
 1 Normal operation

LGC H/L Logic
 0 1.4V/0.4V
 1 2.4V/0.6V

OSDE Open Detection Enable
 00/11 Disable open/short detection
 01 Enable open detection
 10 Enable short detection

SWS SWx Setting
 0000 SW1~SW11, 1/11
 0001 SW1~SW10, 1/10, SW11 no-active
 0010 SW1~SW9, 1/9, SW10~SW11 no-active
 0011 SW1~SW8, 1/8, SW9~SW11 no-active
 0100 SW1~SW7, 1/7, SW8~SW11 no-active
 0101 SW1~SW6, 1/6, SW7~SW11 no-active
 0110 SW1~SW5, 1/5, SW6~SW11 no-active

0111 SW1~SW4, 1/4, SW5~SW11 no-active
 1000 SW1~SW3, 1/3, SW4~SW11 no-active
 1001 SW1~SW2, 1/2, SW3~SW11 no-active
 1010 All CSy work as current sinks only, no scan
 Others Not allowed

Table 10 01h Global Current Control Register

Bit	D7:D0
Name	GCC
Default	0000 0000

The Global Current Control Register modulates all CSy (y=1~18) DC current which is noted as I_{OUT} in 256 steps.

I_{OUT} is computed by the Formula (3):

$$I_{OUT(PEAK)} = \frac{343}{R_{ISET}} \times \frac{GCC}{256} \times \frac{SL}{256} \quad (3)$$

$$GCC = \sum_{n=0}^7 D[n] \cdot 2^n$$

Where D[n] stands for the individual bit value, 1 or 0, in location n.

Table 11 02h Pull Down/Up Resistor Selection Register

Bit	D7	D6:D4	D3	D2:D0
Name	PHC	SWPDR	-	CSPUR
Default	0	011	0	011

Set pull down resistor for SWx and pull up resistor for CSy.

Please check DE-GHOST FUNCTION section for more information.

PHC Phase choice
 0 0 degree phase delay
 1 180 degree phase delay

IS31FL3743A

SWPDR SWx Pull down Resistor Selection Bit

000	No pull down resistor
001	0.5kΩ only in SWx off time
010	1.0kΩ only in SWx off time
011	2.0kΩ only in SWx off time
100	1.0kΩ all the time
101	2.0kΩ all the time
110	4.0kΩ all the time
111	8.0kΩ all the time

CSPUR CSy Pull up Resistor Selection Bit

000	No pull up resistor
001	0.5kΩ only in CSy off time
010	1.0kΩ only in CSy off time
011	2.0kΩ only in CSy off time
100	1.0kΩ all the time
101	2.0kΩ all the time
110	4.0kΩ all the time
111	8.0kΩ all the time

Table 12 Open/Short Register (Read Only)
03h~23h Open/Short Information

Bit	D7:D6	D5:D0
Name	-	CS18:CS13, CS12:CS07,CS06:CS01
Default	00	00 0000

When OSDE (PG2, 00h) is set to “01”, open detection will be trigger once, and the open information will be stored at 03h~23h.

When OSDE (PG2, 00h) set to “10”, short detection will be trigger once, and the short information will be stored at 03h~23h.

Before set OSDE, the GCC should set to 0x0F, please check OPEN/SHORT DETECT FUNCTION section for more information.

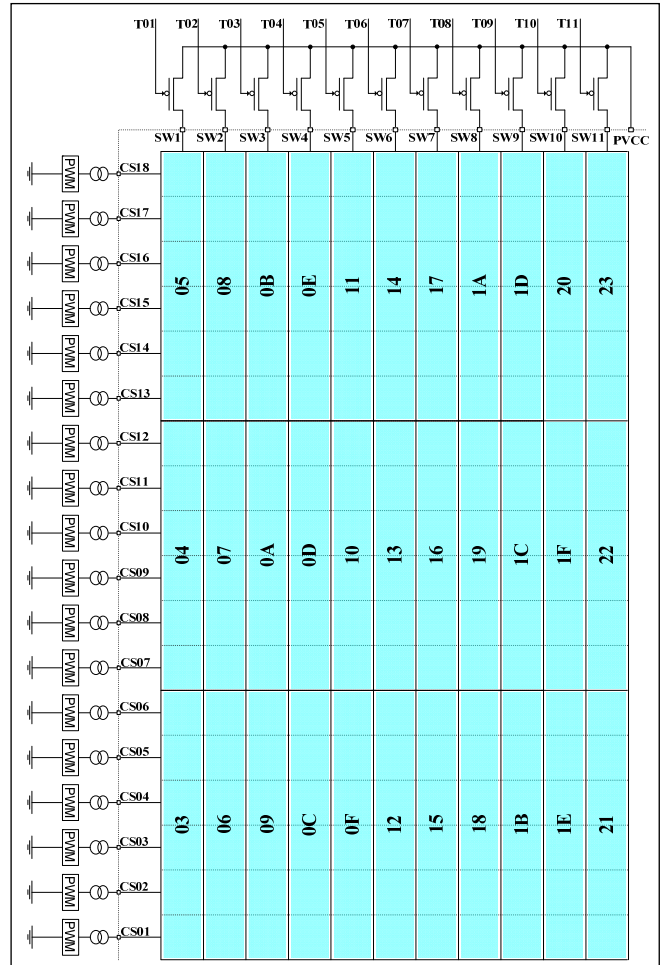

Figure 11 Open/Short Register

Table 13 24h Temperature Status

Bit	D7:D4	D3:D2	D1:D0
Name	-	TS	TROF
Default	0000	00	00

TS store the temperature point of the IC. If the IC temperature reaches the temperature point the IC will trigger the thermal roll off and will decrease the current as TROF set percentage.

TROF percentage of output current

00	100%
01	75%
10	55%
11	30%

TS Temperature Point, Thermal roll off start point

00	140°C
01	120°C
10	100°C
11	90°C

IS31FL3743A

Table 14 25h Spread Spectrum Register

Bit	D7:D6	D5	D4	D3:D2	D1:D0
Name	SYNC	-	SSP	RNG	CLT
Default	00	0	0	00	00

When SYNC bits are set to “11”, the IS31FL3743A is configured as the master clock source and the SYNC pin will generate a clock signal distributed to the clock slave devices. To be configured as a clock slave device and accept an external clock input the slave device’s SYNC bits must be set to “10”.

When SSP enable, the spread spectrum function will be enabled and the RNG & CLT bits will adjust the range and cycle time of spread spectrum function.

SYNC Enable of SYNC function

0x	Disable SYNC function, internal 30kΩ pull-low
10	Slave, clock input
11	Master, clock output

SSP Spread spectrum function enable

0	Disable
1	Enable

RNG Spread spectrum range

00	±5%
01	±15%
10	±24%
11	±34%

CLT Spread spectrum cycle time

00	1980µs
01	1200µs
10	820µs
11	660µs

2Fh Reset Register

Once user writes the Reset Register with 0xAE, IS31FL3743A will reset all the IS31FL3743A registers to their default value. On initial power-up, the IS31FL3743A registers are reset to their default values for a blank display.

IS31FL3743A

APPLICATION INFORMATION

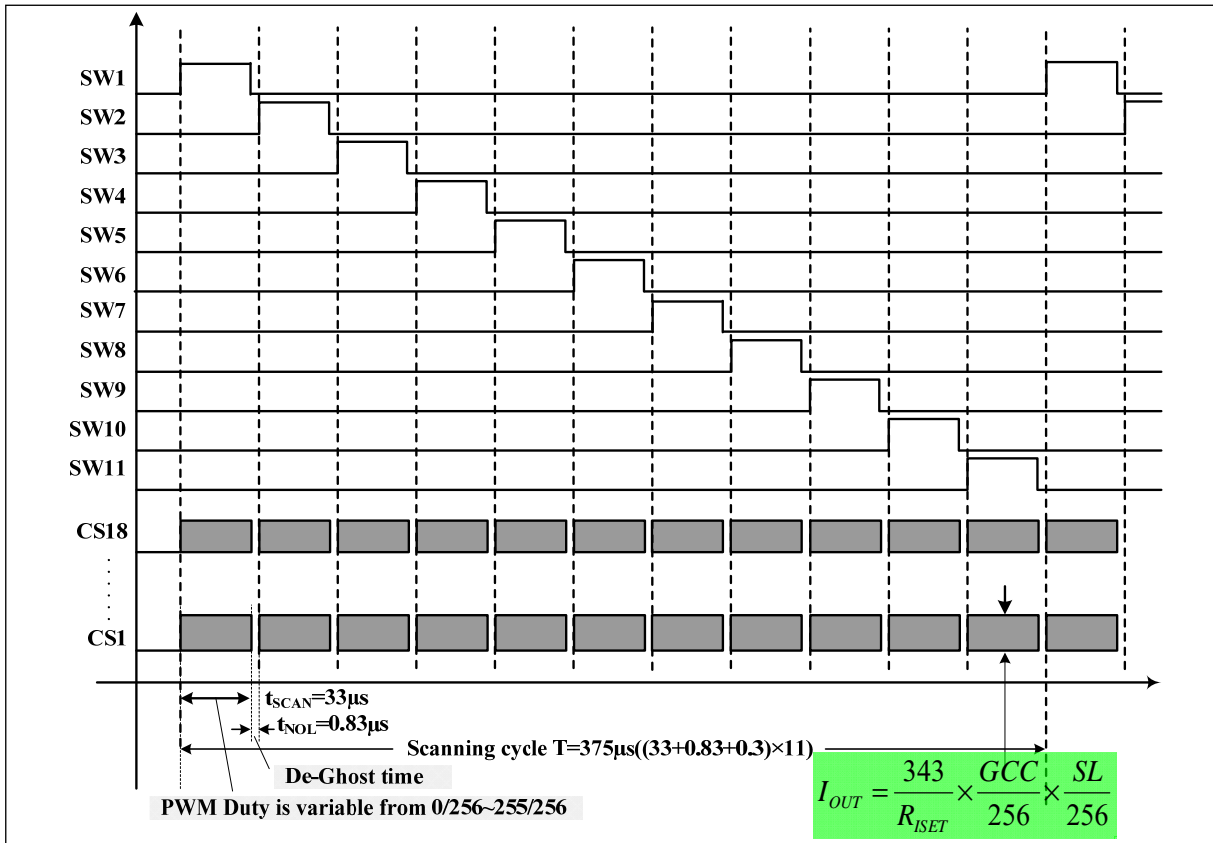

Figure 12 Scanning Timing

SCANNING TIMING

As shown in Figure 12 above, the SW1~SW11 is turned on by serial, LED is driven 11 by 11 within the SWx (x=1~11) on time (SWx, x=1~11 is source and it is high when LED on), including the non-overlap blanking time during scan, the duty cycle of SWx (active high, x=1~11) is:

$$Duty = \frac{33\mu s}{(33\mu s + 0.83\mu s + 0.3\mu s)} \times \frac{1}{11} = \frac{1}{11.377} \quad (2)$$

Where 33µs is t_{SCAN}, the period of scanning and 0.83µs is t_{NOL}, the non-overlap time and 0.3µs is the CSy delay time.

PWM CONTROL

After setting the I_{OUT} and GCC, the brightness of each LEDs (LED average current (I_{LED})) can be modulated with 256 steps by PWM Register, as described in Formula (1).

$$I_{LED} = \frac{PWM}{256} \times I_{OUT(PEAK)} \times Duty \quad (1)$$

Where PWM is PWM Registers (PG0, 00h~B3h / PG1, 01h~C6h) data showing in Table 7.

For example, in Figure 1, if R_{SET}= 10kΩ, PWM= 255, and GCC= 255, Scaling= 255, then

$$I_{OUT(PEAK)} = \frac{343}{10k\Omega} \times \frac{255}{256} \times \frac{255}{256} = 34mA$$

$$I_{LED} = 34mA \times \frac{1}{11.377} \times \frac{PWM}{256}$$

Writing new data continuously to the registers can modulate the brightness of the LEDs to achieve a breathing effect.

GAMMA CORRECTION

In order to perform a better visual LED breathing effect we recommend using a gamma corrected PWM value to set the LED intensity. This results in a reduced number of steps for the LED intensity setting, but causes the change in intensity to appear more linear to the human eye.

Gamma correction, also known as gamma compression or encoding, is used to encode linear luminance to match the non-linear characteristics of display. Since the IS31FL3743A can modulate the brightness of the LEDs with 256 steps, a gamma correction function can be applied when computing each subsequent LED intensity setting such that the changes in brightness matches the human eye's brightness curve.

IS31FL3743A

Table 15 32 Gamma Steps with 256 PWM Steps

C(0)	C(1)	C(2)	C(3)	C(4)	C(5)	C(6)	C(7)
0	1	2	4	6	10	13	18
C(8)	C(9)	C(10)	C(11)	C(12)	C(13)	C(14)	C(15)
22	28	33	39	46	53	61	69
C(16)	C(17)	C(18)	C(19)	C(20)	C(21)	C(22)	C(23)
78	86	96	106	116	126	138	149
C(24)	C(25)	C(26)	C(27)	C(28)	C(29)	C(30)	C(31)
161	173	186	199	212	226	240	255

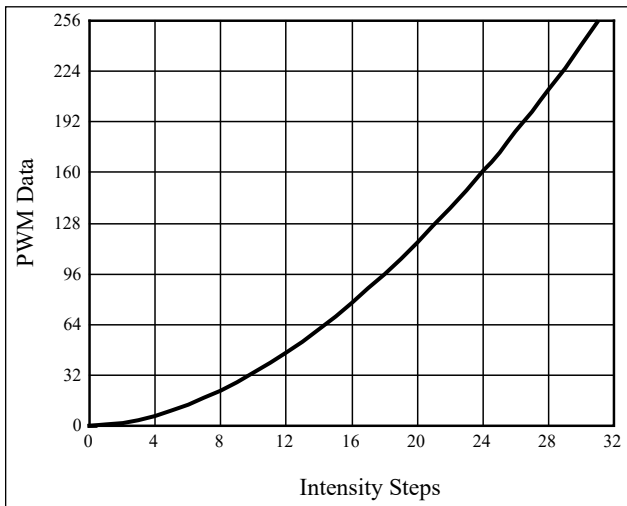

Figure 13 Gamma Correction (32 Steps)

Choosing more gamma steps provides for a more continuous looking breathing effect. This is useful for very long breathing cycles. The recommended configuration is defined by the breath cycle T. When T=1s, choose 32 gamma steps, when T=2s, choose 64 gamma steps. The user must decide the final number of gamma steps not only by the LED itself, but also based on the visual performance of the finished product.

Table 16 64 Gamma Steps with 256 PWM Steps

C(0)	C(1)	C(2)	C(3)	C(4)	C(5)	C(6)	C(7)
0	1	2	3	4	5	6	7
C(8)	C(9)	C(10)	C(11)	C(12)	C(13)	C(14)	C(15)
8	10	12	14	16	18	20	22
C(16)	C(17)	C(18)	C(19)	C(20)	C(21)	C(22)	C(23)
24	26	29	32	35	38	41	44
C(24)	C(25)	C(26)	C(27)	C(28)	C(29)	C(30)	C(31)
47	50	53	57	61	65	69	73
C(32)	C(33)	C(34)	C(35)	C(36)	C(37)	C(38)	C(39)
77	81	85	89	94	99	104	109
C(40)	C(41)	C(42)	C(43)	C(44)	C(45)	C(46)	C(47)
114	119	124	129	134	140	146	152
C(48)	C(49)	C(50)	C(51)	C(52)	C(53)	C(54)	C(55)
158	164	170	176	182	188	195	202
C(56)	C(57)	C(58)	C(59)	C(60)	C(61)	C(62)	C(63)
209	216	223	230	237	244	251	255

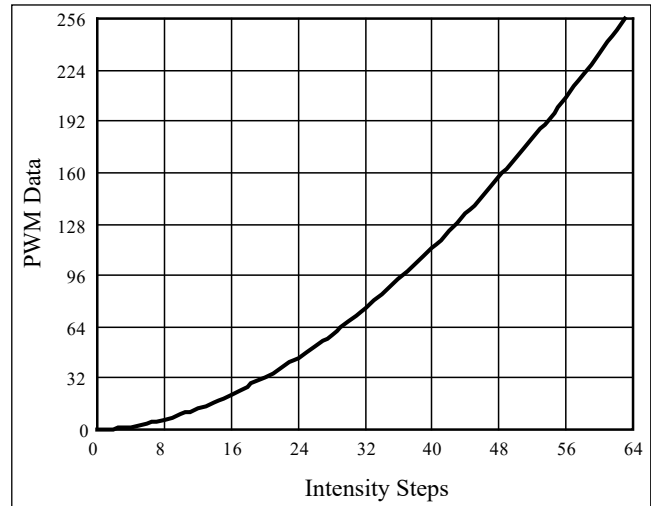

Figure 14 Gamma Correction (64 Steps)

Note: The data of 32 gamma steps is the standard value and the data of 64 gamma steps is the recommended value.

OPERATING MODE

IS31FL3743A can only operate in PWM Mode. The brightness of each LED can be modulated with 256 steps by PWM registers. For example, if the data in PWM Register is “0000 0100”, then the PWM is the fourth step.

Writing new data continuously to the registers can modulate the brightness of the LEDs to achieve a breathing effect.

OPEN/SHORT DETECT FUNCTION

IS31FL3743A has open and short detect bit for each LED.

By setting the OSD bits of the Configuration Register (PG2, 00h) from “00” to “01” or ‘10’, the LED Open/short Register will start to store the open/short information and after at least 2 scanning cycles and the MCU can get the open/short information by reading the 03h~23h, for those dots are turned off via LED On/Off Registers (PG0, 00h~17h), the open/short data will not get refreshed when setting the OSD bit of the Configuration Register.

The two configurations need to set before setting the OSD bits:

- 1 0x0F≤GCC≤0x40, 02h=0x00
- 2 0x01≤GCC≤0x40, 02h=0x30

Where GCC is the Global Current Control Register (PG2, 01h) and both case 1 or two can get the correct open and short information. 02h is the Pull Down/UP Resistor Selection Register and 0x30 is to enable the SWx pull-up function.

The detect action is one-off event and each time before reading out the open/short information, the OSD bit of the Configuration Register (PG3, 00h) need to be set from “0” to “1” (clear before set operation).

IS31FL3743A

DE-GHOST FUNCTION

The “ghost” term is used to describe the behavior of an LED that should be OFF but instead glows dimly when another LED is turned ON. A ghosting effect typically can occur when multiplexing LEDs. In matrix architecture any parasitic capacitance found in the constant-current outputs or the PCB traces to the LEDs may provide sufficient current to dimly light an LED to create a ghosting effect.

To prevent this LED ghost effect, the IS31FL3743A has integrated Pull down resistors for each SWx (x=1~11) and Pull up resistors for each CSy (y=1~18). Select the right SWx Pull down resistor (PG2, 02h) and CSy Pull up resistor (PG2, 02h) which eliminates the ghost LED for a particular matrix layout configuration.

Typically, selecting the 2k Ω will be sufficient to eliminate the LED ghost phenomenon.

The SWx Pull down resistors and CSy Pull up resistors are active only when the CSy/SWx output working the OFF state and therefore no power is lost through these resistors.

SHUTDOWN MODE

Shutdown mode can be used as a means of reducing power consumption. During shutdown mode all registers retain their data.

Software Shutdown

By setting SSD bit of the Configuration Register (PG2, 00h) to “0”, the IS31FL3743A will operate in software shutdown mode. When the IS31FL3743A is in software shutdown, all current sources are switched off, so that the matrix is blanked. All registers can be operated. Typical current consume is 1.3 μ A.

Hardware Shutdown

The chip enters hardware shutdown when the SDB pin is pulled low. All analog circuits are disabled during hardware shutdown, typical the current consume is 1.3 μ A.

The chip releases hardware shutdown when the SDB pin is pulled high. During hardware shutdown state Function Register can be operated.

If VCC has risk drop below 1.75V but above 0.1V during SDB pulled low, please re-initialize all Function Registers before SDB pulled high.

LAYOUT

As described in external resistor (R_{ISET}), the chip consumes lots of power. Please consider below factors when layout the PCB.

1. The V_{CC} (PVCC, AVCC) capacitors need to close to the chip and the ground side should well connected to the GND of the chip.
2. R_{ISET} should be close to the chip and the ground side should well connect to the GND of the chip.
3. The thermal pad should connect to ground pins and the PCB should have the thermal pad too, usually this pad should have 16 or 25 via thru the PCB to other side’s ground area to help radiate the heat. About the thermal pad size, please refer to the land pattern of each package.
4. The CSy pins maximum current is 34mA ($R_{\text{ISET}}=10\text{k}\Omega$), and the SWx pins maximum current is larger, the width of the trace, SWx should have wider trace than CSy.

IS31FL3743A

CLASSIFICATION REFLOW PROFILES

Profile Feature	Pb-Free Assembly
Preheat & Soak Temperature min (T _{smin}) Temperature max (T _{smax}) Time (T _{smin} to T _{smax}) (t _s)	150°C 200°C 60-120 seconds
Average ramp-up rate (T _{smax} to T _p)	3°C/second max.
Liquidous temperature (T _L) Time at liquidous (t _L)	217°C 60-150 seconds
Peak package body temperature (T _p)*	Max 260°C
Time (t _p)** within 5°C of the specified classification temperature (T _c)	Max 30 seconds
Average ramp-down rate (T _p to T _{smax})	6°C/second max.
Time 25°C to peak temperature	8 minutes max.

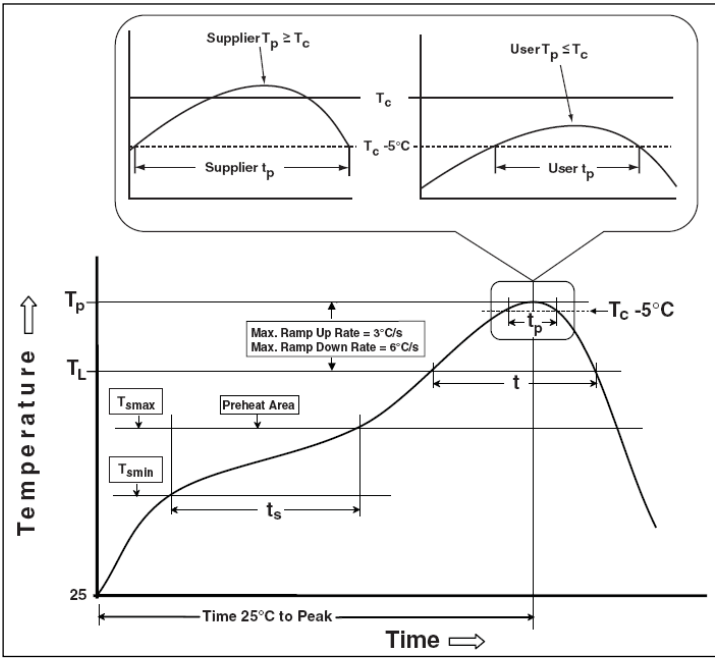
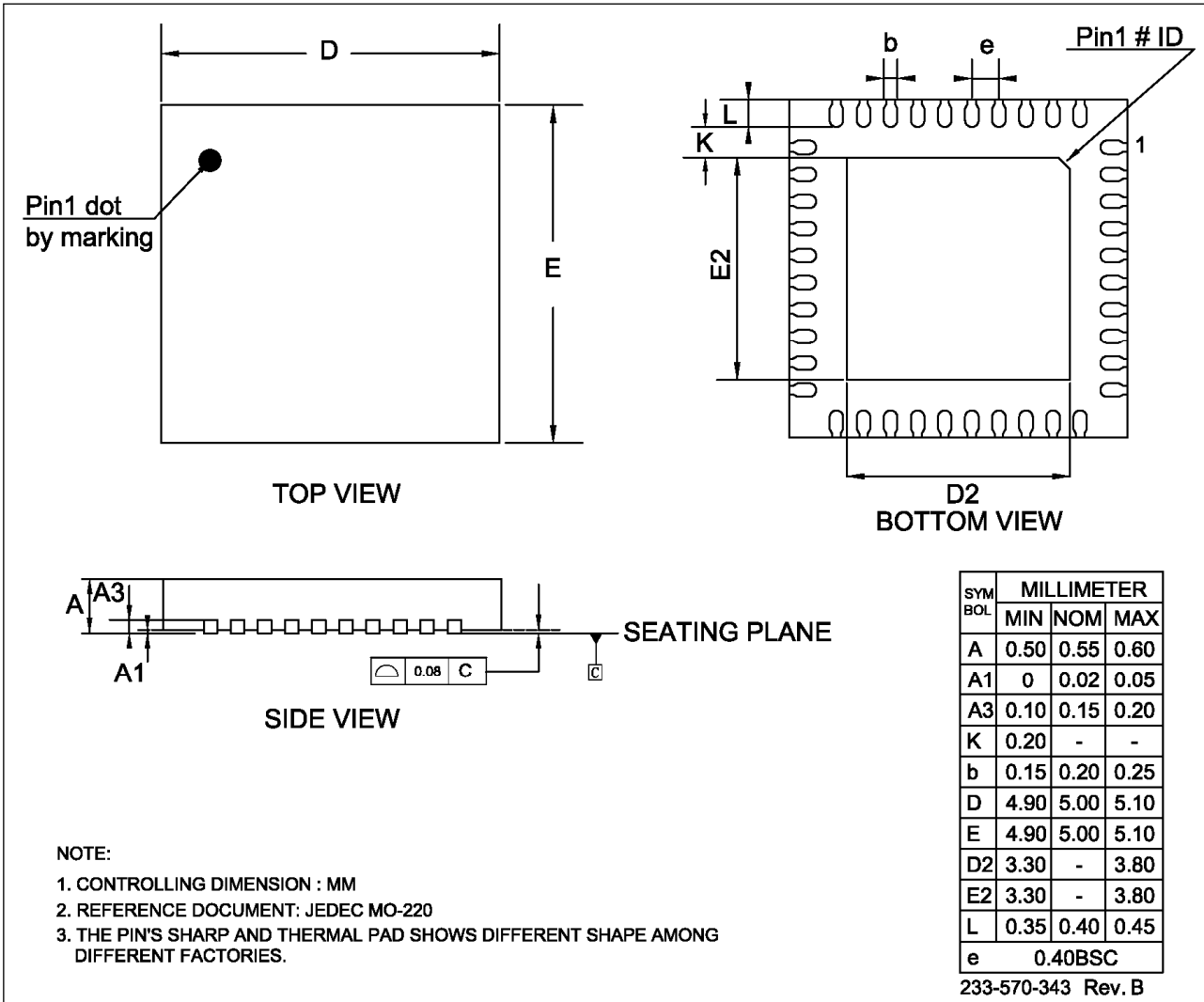

Figure 15 Classification Profile

IS31FL3743A

PACKAGE INFORMATION

UQFN-40



NOTE:

1. CONTROLLING DIMENSION : MM
2. REFERENCE DOCUMENT: JEDEC MO-220
3. THE PIN'S SHARP AND THERMAL PAD SHOWS DIFFERENT SHAPE AMONG DIFFERENT FACTORIES.

IS31FL3743A

RECOMMENDED LAND PATTERN

UQFN-40

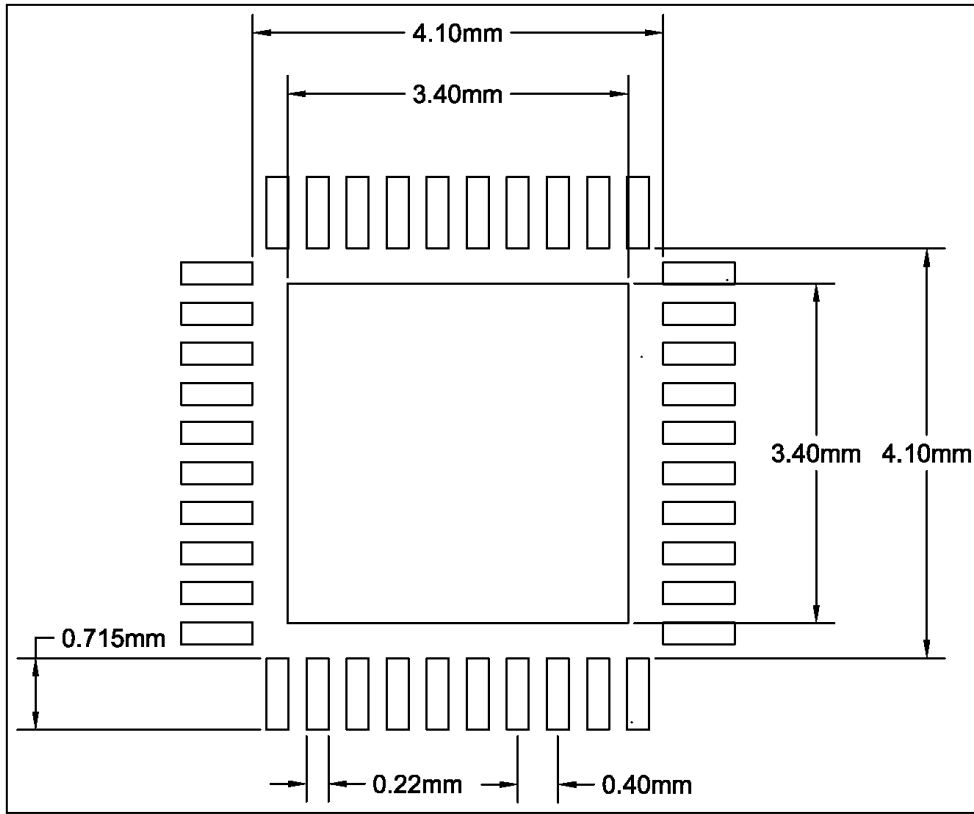

Note:

1. Land pattern complies to IPC-7351.
2. All dimensions in MM.
3. This document (including dimensions, notes & specs) is a recommendation based on typical circuit board manufacturing parameters. Since land pattern design depends on many factors unknown (eg. User's board manufacturing specs), user must determine suitability for use.

REVISION HISTORY

Revision	Detail Information	Date
A	Initial release	2018.08.06
B	1. Correct mistake in Table 6 and 11 2. Update Figure 8	2022.04.07

Looking for pricing, stock, or lifecycle information?

Click below to explore more details on WIN SOURCE:

- [View IS31FL3743A-QULS4-TR on WIN SOURCE](#)
- [Lumissil Microsystems Information](#)

Optimize Your Supply Chain with WIN SOURCE Solutions

- ✓ Global Sourcing Solution
- ✓ Obsolete Management
- ✓ Cost Control Management
- ✓ Shortage Management
- ✓ Alternative Solution
- ✓ Excess Inventory Management