



**THE DATASHEET OF
TLV9032QPWRQ1**



TLV902x-Q1 and TLV903x-Q1 Precision Automotive Comparator Family

1 Features

- Qualified for automotive applications
- AEC-Q100 qualified with the following results:
 - Device temperature grade 1: -40°C to 125°C ambient operating temperature range
 - Device HBM ESD classification level 2
 - Device CDM ESD classification level C6
- 1.65V to 5.5V supply range
- Power-On Reset (POR) for known start-up
- Precision input offset voltage $300\mu\text{V}$
- 100ns Typical propagation delay
- Low quiescent current $16\mu\text{A}$ per channel
- Rail-to-Rail input voltage range exceeds the rails
- Open-drain output option (TLV902x-Q1)
- Push-pull output option (TLV903x-Q1)
- Alternate single pinout option (TLV90x0)
- 2kV ESD Protection

2 Applications

- **Automotive**
 - HEV/EV and power train
 - Infotainment and cluster
 - Body control module
- **Industrial**

3 Description

The TLV902x-Q1 and TLV903x-Q1 are a family of Automotive grade single, dual and quad channel comparators. The family offers low input offset voltage, fault-tolerant inputs and an excellent speed-to-power combination with a propagation delay of 100ns with a quiescent supply current of only $18\mu\text{A}$ per channel.

The family also includes a Power-on Reset (POR) feature that makes sure the output is in a known state until the minimum supply voltage has been reached to prevent output transients during system power-up and power-down.

These comparators also feature fault-tolerant inputs that can go up to 6V without damage with no output phase inversion. This makes this family of comparators designed for precision voltage monitoring in harsh, noisy environments.

The TLV902x-Q1 have an open-drain output that may be pulled-up below or beyond the supply voltage, making it appropriate for low voltage logic translators.

The TLV903x-Q1 have a push-pull output stage capable of sinking and sourcing many milliamps of current to drive LEDs or a capacitive load such as a MOSFET gate.

The TLV90x0-Q1 and TLV90x1-Q1 are alternate pinouts of the single device.

The family is specified for the Automotive temperature range of -40°C to $+125^{\circ}\text{C}$ and are available in a standard leaded and leadless packages.

Device Information

PART NUMBER	PACKAGE ⁽¹⁾	BODY SIZE (NOM) ⁽²⁾
TLV90x0-Q1, TLV90x1-Q1 (Single)	SC-70 (5)	1.25mm x 2.00mm
	SOT-23 (5)	1.60mm x 2.90mm
TLV9022-Q1, TLV9032-Q1 (Dual)	SOIC (8)	3.91mm x 4.90mm
	TSSOP (8)	3.00mm x 4.40mm
	VSSOP (8)	3.00mm x 3.00mm
	WSON (8)	2.00mm x 2.00mm
	SOT-23-THN (8)	1.60mm x 2.90mm
TLV9024-Q1, TLV9034-Q1 (Quad)	SOIC (14)	3.91mm x 8.65mm
	TSSOP (14)	4.40mm x 5.00mm
	SOT-23 (14)	4.20mm x 2.00mm
	WQFN (16)	3.00mm x 3.00mm

- (1) For all available packages, see the orderable addendum at the end of the data sheet.
- (2) The package size (length x width) is a nominal value and includes pins, where applicable.

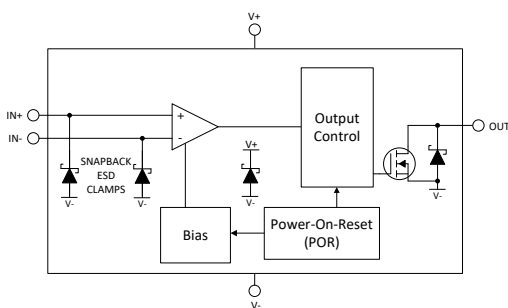

TLV902x-Q1 Block Diagram

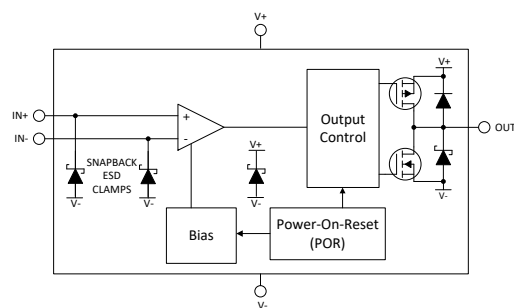

TLV903x-Q1 Block Diagram

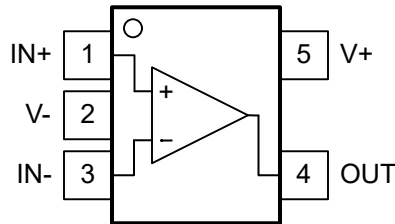

Table of Contents

1 Features	1	5.13 Typical Characteristics.....	14
2 Applications	1	6 Detailed Description	20
3 Description	1	6.1 Overview.....	20
4 Pin Configuration and Functions	3	6.2 Functional Block Diagram.....	20
4.1 Pin Functions: TLV90x0-Q1 and TLV90x1-Q1 Single.....	3	6.3 Feature Description.....	20
Pin Functions: TLV90x2-Q1 Dual.....	4	6.4 Device Functional Modes.....	20
Pin Functions: TLV90x4-Q1 Quad.....	5	7 Application and Implementation	24
5 Specifications	6	7.1 Application Information.....	24
5.1 Absolute Maximum Ratings.....	6	7.2 Typical Applications.....	27
5.2 ESD Ratings.....	6	7.3 Power Supply Recommendations.....	34
5.3 Recommended Operating Conditions.....	6	8 Layout	35
5.4 Thermal Information, TLV90x0-Q1, TLV90x1-Q1	6	8.1 Layout Guidelines.....	35
5.5 Thermal Information, TLV90x2-Q1	7	8.2 Layout Example.....	35
5.6 Thermal Information, TLV90x4-Q1	7	9 Device and Documentation Support	36
5.7 Electrical Characteristics, TLV90x0- Q1, TLV90x1-Q1	8	9.1 Documentation Support.....	36
5.8 Switching Characteristics, TLV90x0- Q1, TLV90x1-Q1	9	9.2 Receiving Notification of Documentation Updates....	36
5.9 Electrical Characteristics, TLV90x2-Q1	10	9.3 Support Resources.....	36
5.10 Switching Characteristics, TLV90x2-Q1	11	9.4 Trademarks.....	36
5.11 Electrical Characteristics, TLV90x4-Q1	12	9.5 Electrostatic Discharge Caution.....	36
5.12 Switching Characteristics, TLV90x4-Q1	13	9.6 Glossary.....	36
		10 Revision History	36
		11 Mechanical, Packaging, and Orderable Information	37

4 Pin Configuration and Functions

4.1 Pin Functions: TLV90x0-Q1 and TLV90x1-Q1 Single



**Figure 4-1. TLV9020-Q1, TLV9030-Q1 DCK and DBV Packages
 Standard "South East" Pinout
 5-Pin SC-70 and SOT-23
 Top View**

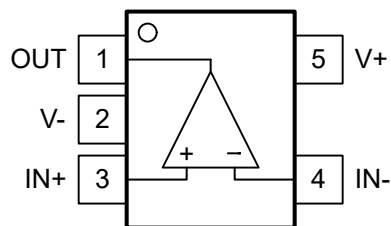
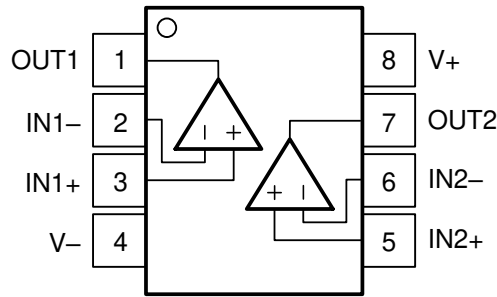

**Figure 4-2. TLV9021-Q1, TLV9031-Q1 DCK and DBV Packages
 Standard "North West" Pinout
 5-Pin SC-70 and SOT-23
 Top View**

Table 4-1. Pin Functions: TLV90x0-Q1 and TLV90x1-Q1

NAME	PIN		TYPE	DESCRIPTION
	TLV90x0-Q1 NO.	TLV90x1-Q1 NO.		
IN+	1	3	I	Non-Inverting (Positive) Input
IN-	3	4	I	Inverting (Negative) Input
OUT	4	1	O	Output
V+	5	5	—	Positive Power Supply
V-	2	2	—	Negative Power Supply

Pin Functions: TLV90x2-Q1 Dual



**Figure 4-3. D, DGK, PW, DDF Packages
 8-Pin SOIC, VSSOP, TSSOP, SOT-23-8
 Top View**

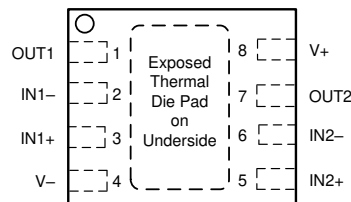

NOTE: Connect exposed thermal pad directly to V- pin.

**Figure 4-4. DSG Package
 8-Pad WSON With Exposed Thermal Pad
 Top View**

Table 4-2. Pin Functions: TLV90x2-Q1

PIN		I/O	DESCRIPTION
NAME	NO.		
OUT1	1	O	Output pin of the comparator 1
IN1-	2	I	Inverting input pin of comparator 1
IN1+	3	I	Noninverting input pin of comparator 1
V-	4	—	Negative (low) supply
IN2+	5	I	Noninverting input pin of comparator 2
IN2-	6	I	Inverting input pin of comparator 2
OUT2	7	O	Output pin of the comparator 2
V+	8	—	Positive supply
Thermal Pad	—	—	Connect directly to V- pin

Pin Functions: TLV90x4-Q1 Quad

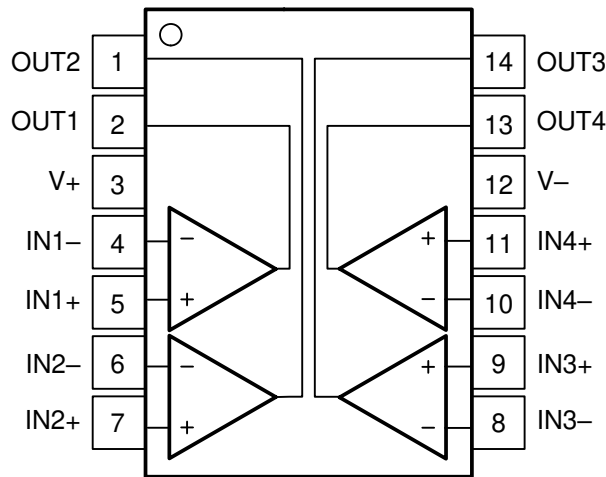

**Figure 4-5. D, PW, DYY Package,
14-Pin SOIC, TSSOP, SOT-23,
Top View**

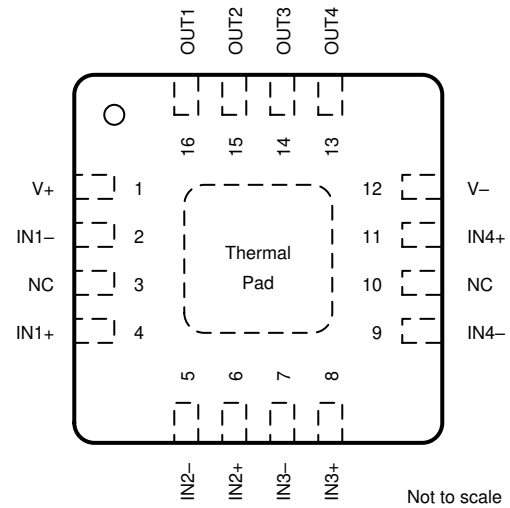

NOTE: Connect exposed thermal pad directly to V- pin.

**Figure 4-6. RTE Package,
16-Pad WQFN With Exposed Thermal Pad,
Top View**

Table 4-3. Pin Functions: TLV90x4-Q1

NAME ⁽¹⁾	PIN		I/O	DESCRIPTION
	SOIC	WQFN		
OUT2	1	15	Output	Output pin of the comparator 2
OUT1	2	16	Output	Output pin of the comparator 1
V+	3	1	—	Positive supply
IN1-	4	2	Input	Negative input pin of the comparator 1
IN1+	5	4	Input	Positive input pin of the comparator 1
IN2-	6	5	Input	Negative input pin of the comparator 2
IN2+	7	6	Input	Positive input pin of the comparator 2
IN3-	8	7	Input	Negative input pin of the comparator 3
IN3+	9	8	Input	Positive input pin of the comparator 3
IN4-	10	9	Input	Negative input pin of the comparator 4
IN4+	11	11	Input	Positive input pin of the comparator 4
V-	12	12	—	Negative supply
OUT4	13	13	Output	Output pin of the comparator 4
OUT3	14	14	Output	Output pin of the comparator 3
NC	—	3	—	No Internal Connection - Leave floating or GND
NC	—	10	—	No Internal Connection - Leave floating or GND
Thermal Pad	—	PAD	—	Connect directly to V- pin.

(1) Some manufacturers transpose the names of channels 1 & 2. Electrically the pinouts are identical, just a difference in channel naming convention.

5 Specifications

5.1 Absolute Maximum Ratings

over operating free-air temperature range (unless otherwise noted)⁽¹⁾

	MIN	MAX	UNIT
Supply voltage: $V_S = (V+) - (V-)$	-0.3	6	V
Input pins (IN+, IN-) from $V-$ ⁽²⁾	-0.3	6	V
Current into Input pins (IN+, IN-)	-10	10	mA
Output (OUT) from $V-$, open drain only ⁽³⁾	-0.3	6	V
Output (OUT) from $V-$, push-pull only	-0.3	$(V+) + 0.3$	V
Output short circuit duration ⁽⁴⁾		10	s
Junction temperature, T_J		150	°C
Storage temperature, T_{stg}	-65	150	°C

- (1) Stresses beyond those listed under *Absolute Maximum Ratings* may cause permanent damage to the device. These are stress ratings only, which do not imply functional operation of the device at these or any other conditions beyond those indicated under *Recommended Operating Conditions*. Exposure to absolute-maximum-rated conditions for extended periods may affect device reliability.
- (2) Input terminals are diode-clamped to $(V-)$. Input signals that can swing more than 0.3V beyond the supply rails must be current-limited to 10mA or less. Additionally, Inputs (IN+, IN-) can be greater than $V+$ and OUT as long as it is within the -0.3V to 6V range
- (3) Output (OUT) for open drain can be greater than $V+$ and inputs (IN+, IN-) as long as it is within the -0.3V to 6V range
- (4) Short-circuit to $V-$ or $V+$. Short circuits from outputs can cause excessive heating and eventual destruction.

5.2 ESD Ratings

		VALUE	UNIT
$V_{(ESD)}$	Electrostatic discharge	Human-body model (HBM), , per AEC Q100-002 ⁽¹⁾	±2000
		Charged-device model (CDM), per AEC Q100-0111	±1000

- (1) AEC Q100-002 indicates that HBM stressing shall be in accordance with the ANSI/ESDA/JEDEC JS-001 specification.

5.3 Recommended Operating Conditions

over operating free-air temperature range (unless otherwise noted)

	MIN	MAX	UNIT
Supply voltage: $V_S = (V+) - (V-)$	1.65	5.5	V
Input voltage range (IN+, IN-) from $(V-)$	-0.2	5.7	V
Ambient temperature, T_A	-40	125	°C

5.4 Thermal Information, TLV90x0-Q1, TLV90x1-Q1

THERMAL METRIC ⁽¹⁾		TLV90x0-Q1, TLV90x1-Q1		UNIT
		DCK (SC-70)	DBV (SOT-23)	
		5 PINS	5 PINS	
R_{qJA}	Junction-to-ambient thermal resistance	238.5	223.7	°C/W
$R_{qJC(top)}$	Junction-to-case (top) thermal resistance	134.0	123.2	°C/W
R_{qJB}	Junction-to-board thermal resistance	87.6	91.4	°C/W
γ_{JT}	Junction-to-top characterization parameter	59.1	58.7	°C/W
γ_{JB}	Junction-to-board characterization parameter	87.2	91.0	°C/W
$R_{qJC(bot)}$	Junction-to-case (bottom) thermal resistance	–	–	°C/W

- (1) For more information about traditional and new thermal metrics, see the [Semiconductor and IC Package Thermal Metrics](#) application report.

5.5 Thermal Information, TLV90x2-Q1

THERMAL METRIC ⁽¹⁾		TLV90x2-Q1					UNIT
		D (SOIC)	PW (TSSOP)	DGK (VSSOP)	DSG (WSON)	DDF (SOT-23)	
		8 PINS	8 PINS	8 PINS	8 PINS	8 PINS	
R _{qJA}	Junction-to-ambient thermal resistance	167.7	221.7	215.8	175.2	240.0	°C/W
R _{qJC(top)}	Junction-to-case (top) thermal resistance	107.0	109.1	105.2	178.1	151.0	°C/W
R _{qJB}	Junction-to-board thermal resistance	111.2	152.5	137.5	139.5	157.0	°C/W
Y _{JT}	Junction-to-top characterization parameter	53.1	36.4	39.6	47.2	32.8	°C/W
Y _{JB}	Junction-to-board characterization parameter	110.4	150.7	135.9	138.9	155.4	°C/W
R _{qJC(bot)}	Junction-to-case (bottom) thermal resistance	–	–	–	127.3	–	°C/W

(1) For more information about traditional and new thermal metrics, see the [Semiconductor and IC Package Thermal Metrics](#) application report.

5.6 Thermal Information, TLV90x4-Q1

THERMAL METRIC ⁽¹⁾		TLV90x4-Q1				UNIT
		D (SOIC)	PW (TSSOP)	RTE (WQFN)	DYY (SOT-23)	
		14 PINS	14 PINS	16 PINS	14 PINS	
R _{qJA}	Junction-to-ambient thermal resistance	136.0	155.0	134.1	211.1	°C/W
R _{qJC(top)}	Junction-to-case (top) thermal resistance	91.2	82.0	122.6	121.1	°C/W
R _{qJB}	Junction-to-board thermal resistance	92.0	98.5	109.3	120.4	°C/W
Y _{JT}	Junction-to-top characterization parameter	46.9	25.7	30.9	22.3	°C/W
Y _{JB}	Junction-to-board characterization parameter	91.6	97.6	108.3	120.1	°C/W
R _{qJC(bot)}	Junction-to-case (bottom) thermal resistance	–	–	98.7	–	°C/W

(1) For more information about traditional and new thermal metrics, see the [Semiconductor and IC Package Thermal Metrics](#) application report.

5.7 Electrical Characteristics, TLV90x0-Q1, TLV90x1-Q1

For V_S (Total Supply Voltage) = $(V+) - (V-) = 5V$, $V_{CM} = (V-)$ at $T_A = 25^\circ C$ (Unless otherwise noted)

PARAMETER		TEST CONDITIONS	MIN	TYP	MAX	UNIT
OFFSET VOLTAGE						
V_{OS}	Input offset voltage	$V_S = 1.8V$ and $5V$	-1.5	± 0.3	1.5	mV
V_{OS}	Input offset voltage	$V_S = 1.8V$ and $5V$, $T_A = -40^\circ C$ to $+125^\circ C$	-2		2	
dV_{IO}/dT	Input offset voltage drift	$V_S = 1.8V$ and $5V$, $T_A = -40^\circ C$ to $+125^\circ C$		± 0.5		$\mu V/^\circ C$
POWER SUPPLY						
I_Q	Quiescent current	$V_S = 1.8V$ and $5V$, No Load, Output Low		17.1	30	μA
I_Q	Quiescent current	$V_S = 1.8V$ and $5V$, No Load, Output Low, $T_A = -40^\circ C$ to $+125^\circ C$			35	
PSRR	Power-supply rejection ratio	$V_S = 1.8V$ to $5V$, $T_A = -40^\circ C$ to $+125^\circ C$ (push-pull version)	75	95		dB
PSRR	Power-supply rejection ratio	$V_S = 1.8V$ to $5V$, $T_A = -40^\circ C$ to $+125^\circ C$ (open drain version)	80	95		dB
INPUT BIAS CURRENT						
I_B	Input bias current	$V_{CM} = V_S/2$		5		pA
I_{OS}	Input offset current	$V_{CM} = V_S/2$		1		pA
INPUT CAPACITANCE						
C_{ID}	Input Capacitance, Differential	$V_{CM} = V_S/2$		2		pF
C_{IC}	Input Capacitance, Common Mode	$V_{CM} = V_S/2$		3		pF
INPUT VOLTAGE RANGE						
$V_{CM-Range}$	Common-mode voltage range	$V_S = 1.8V$ and $5V$, $T_A = -40^\circ C$ to $+125^\circ C$	$(V-) - 0.2$		$(V+) + 0.2$	V
CMRR	Common-mode rejection ratio	$V_S = 5V$, $(V-) - 0.2V < V_{CM} < (V+) + 0.2V$, $T_A = -40^\circ C$ to $+125^\circ C$	60	70		dB
CMRR	Common-mode rejection ratio	$V_S = 1.8V$, $(V-) - 0.2V < V_{CM} < (V+) + 0.2V$, $T_A = -40^\circ C$ to $+125^\circ C$	50	60		dB
OPEN-LOOP GAIN						
A_{VD}	Large signal differential voltage amplification	For open drain version only	50	200		V/mV
OUTPUT						
V_{OL}	Voltage swing from $(V-)$	$I_{SINK} = 4mA$, $T_A = 25^\circ C$		75	125	mV
V_{OL}	Voltage swing from $(V-)$	$I_{SINK} = 4mA$, $T_A = -40^\circ C$ to $+125^\circ C$			175	mV
V_{OH}	Voltage swing from $(V+)$	$I_{SOURCE} = 4mA$, $T_A = 25^\circ C$ (push-pull only)		75	125	mV
V_{OH}	Voltage swing from $(V+)$	$I_{SOURCE} = 4mA$, $T_A = -40^\circ C$ to $+125^\circ C$ (push-pull only)			175	mV
I_{LKG}	Open-drain output leakage current	$V_{PULLUP} = (V+)$, $T_A = 25^\circ C$ (open drain only)		100		pA
I_{SC}	Short-circuit current	$V_S = 5V$, Sinking	90	100		mA
I_{SC}	Short-circuit current	$V_S = 5V$, Sourcing (push-pull only)	90	100		mA

5.8 Switching Characteristics, TLV90x0-Q1, TLV90x1-Q1

For V_S (Total Supply Voltage) = $(V+) - (-) = 5V$, $V_{CM} = V_S / 2$, $C_L = 15pF$ at $T_A = 25^\circ C$ (Unless otherwise noted)

PARAMETER		TEST CONDITIONS	MIN	TYP	MAX	UNIT
OUTPUT						
T_{PD-HL}	Propagation delay time, high-to-low	$V_{ID} = -100mV$; Delay from mid-point of input to mid-point of output ($R_P = 2.5K\Omega$ for open drain only)		100		ns
T_{PD-LH}	Propagation delay time, low-to-high	$V_{ID} = 100mV$; Delay from mid-point of input to mid-point of output (for push-pull only)		115		ns
T_{PD-LH}	Propagation delay time, low-to-high	$V_{ID} = 100mV$; Delay from mid-point of input to mid-point of output ($R_P = 2.5K\Omega$ for open drain only)		150		ns
T_{FALL}	5V Output Fall Time, 80% to 20%	$V_{ID} = -100mV$		3		ns
T_{RISE}	5V Output Rise Time, 20% to 80%	$V_{ID} = 100mV$ (for push-pull only)		3		ns
F_{TOGGLE}	5V, Toggle Frequency	$V_{ID} = 100mV$ ($R_P = 2.5K\Omega$ for open drain only)		3		MHz
POWER ON TIME						
P_{ON}	Power on-time	$V_S = 1.8V$ and $5V$, $V_{CM} = (V-)$, $V_{ID} = -0.1V$, $V_{PULL-UP} = V_S / 2$, Delay from $V_S / 2$ to $V_{OUT} = 0.1 \times V_S / 2$ ($R_P = 2.5K\Omega$ for open drain only)		20		μs

5.9 Electrical Characteristics, TLV90x2-Q1

For V_S (Total Supply Voltage) = $(V+) - (V-) = 5V$, $V_{CM} = (V-)$ at $T_A = 25^\circ\text{C}$ (Unless otherwise noted)

PARAMETER		TEST CONDITIONS	MIN	TYP	MAX	UNIT
OFFSET VOLTAGE						
V_{OS}	Input offset voltage	$V_S = 1.8V$ and $5V_x$	-1.5	± 0.3	1.5	mV
V_{OS}	Input offset voltage	$V_S = 1.8V$ and $5V$, $T_A = -40^\circ\text{C}$ to $+125^\circ\text{C}$	-2		2	
dV_{IO}/dT	Input offset voltage drift	$V_S = 1.8V$ and $5V$, $T_A = -40^\circ\text{C}$ to $+125^\circ\text{C}$		± 0.5		$\mu\text{V}/^\circ\text{C}$
POWER SUPPLY						
I_Q	Quiescent current per comparator	$V_S = 1.8V$ and $5V$, No Load, Output Low		16	30	μA
I_Q	Quiescent current per comparator	$V_S = 1.8V$ and $5V$, No Load, Output Low, $T_A = -40^\circ\text{C}$ to $+125^\circ\text{C}$			35	
PSRR	Power-supply rejection ratio	$V_S = 1.8V$ to $5V$, $T_A = -40^\circ\text{C}$ to $+125^\circ\text{C}$, (push-pull version)	75	95		dB
PSRR	Power-supply rejection ratio	$V_S = 1.8V$ to $5V$, $T_A = -40^\circ\text{C}$ to $+125^\circ\text{C}$ (open drain version)	80	95		dB
INPUT BIAS CURRENT						
I_B	Input bias current	$V_{CM} = V_S/2$		5		pA
I_{OS}	Input offset current	$V_{CM} = V_S/2$		1		pA
INPUT CAPACITANCE						
C_{ID}	Input Capacitance, Differential	$V_{CM} = V_S/2$		2		pF
C_{IC}	Input Capacitance, Common Mode	$V_{CM} = V_S/2$		3		pF
INPUT VOLTAGE RANGE						
$V_{CM\text{-Range}}$	Common-mode voltage range	$V_S = 1.8V$ and $5V$, $T_A = -40^\circ\text{C}$ to $+125^\circ\text{C}$	$(V-) - 0.2$		$(V+) + 0.2$	V
CMRR	Common-mode rejection ratio	$V_S = 5V$, $(V-) - 0.2V < V_{CM} < (V+) + 0.2V$, $T_A = -40^\circ\text{C}$ to $+125^\circ\text{C}$	60	70		dB
CMRR	Common-mode rejection ratio	$V_S = 1.8V$, $(V-) - 0.2V < V_{CM} < (V+) + 0.2V$, $T_A = -40^\circ\text{C}$ to $+125^\circ\text{C}$	50	60		dB
OPEN-LOOP GAIN						
A_{VD}	Large signal differential voltage amplification	For open drain version only	50	200		V/mV
OUTPUT						
V_{OL}	Voltage swing from (V-)	$I_{SINK} = 4\text{mA}$, $T_A = 25^\circ\text{C}$		75	125	mV
V_{OL}	Voltage swing from (V-)	$I_{SINK} = 4\text{mA}$, $T_A = -40^\circ\text{C}$ to $+125^\circ\text{C}$			175	mV
V_{OH}	Voltage swing from (V+)	$I_{SOURCE} = 4\text{mA}$, $T_A = 25^\circ\text{C}$ (push-pull only)		75	125	mV
V_{OH}	Voltage swing from (V+)	$I_{SOURCE} = 4\text{mA}$, $T_A = -40^\circ\text{C}$ to $+125^\circ\text{C}$ (push-pull only)			175	mV
I_{LKG}	Open-drain output leakage current	$V_{PULLUP} = (V+)$, $T_A = 25^\circ\text{C}$ (open drain only)		100		pA
I_{SC}	Short-circuit current	$V_S = 5V$, Sinking	90	100		mA
I_{SC}	Short-circuit current	$V_S = 5V$, Sourcing (push-pull only)	90	100		mA

5.10 Switching Characteristics, TLV90x2-Q1

For V_S (Total Supply Voltage) = $(V+) - (-) = 5V$, $V_{CM} = V_S / 2$, $C_L = 15pF$ at $T_A = 25^\circ C$ (Unless otherwise noted)

PARAMETER		TEST CONDITIONS	MIN	TYP	MAX	UNIT
OUTPUT						
T_{PD-HL}	Propagation delay time, high-to-low	$V_{ID} = -100mV$; Delay from mid-point of input to mid-point of output ($R_P = 2.5K\Omega$ for open drain only)		100		ns
T_{PD-LH}	Propagation delay time, low-to-high	$V_{ID} = 100mV$; Delay from mid-point of input to mid-point of output (for push-pull only)		115		ns
T_{PD-LH}	Propagation delay time, low-to-high	$V_{ID} = 100mV$; Delay from mid-point of input to mid-point of output ($R_P = 2.5K\Omega$ for open drain only)		150		ns
T_{FALL}	5V Output Fall Time, 80% to 20%	$V_{ID} = -100mV$		3		ns
T_{RISE}	5V Output Rise Time, 20% to 80%	$V_{ID} = 100mV$ (for push-pull only)		3		ns
F_{TOGGLE}	5V, Toggle Frequency	$V_{ID} = 100mV$ ($R_P = 2.5K\Omega$ for open drain only)		3		MHz
POWER ON TIME						
P_{ON}	Power on-time	$V_S = 1.8V$ and $5V$, $V_{CM} = (V-)$, $V_{ID} = -0.1V$, $V_{PULL-UP} = V_S / 2$, Delay from $V_S / 2$ to $V_{OUT} = 0.1 \times V_S / 2$ ($R_P = 2.5K\Omega$ for open drain only)		20		μs

5.11 Electrical Characteristics, TLV90x4-Q1

For V_S (Total Supply Voltage) = $(V+) - (V-) = 5V$, $V_{CM} = (V-)$ at $T_A = 25^\circ C$ (Unless otherwise noted)

PARAMETER		TEST CONDITIONS	MIN	TYP	MAX	UNIT
OFFSET VOLTAGE						
V_{OS}	Input offset voltage	$V_S = 1.8V$ and $5V_x$	-1.5	± 0.3	1.5	mV
V_{OS}	Input offset voltage	$V_S = 1.8V$ and $5V$, $T_A = -40^\circ C$ to $+125^\circ C$	-2		2	
dV_{IO}/dT	Input offset voltage drift	$V_S = 1.8V$ and $5V$, $T_A = -40^\circ C$ to $+125^\circ C$		± 0.5		$\mu V/^\circ C$
POWER SUPPLY						
I_Q	Quiescent current per comparator	$V_S = 1.8V$ and $5V$, No Load, Output Low		16	30	μA
I_Q	Quiescent current per comparator	$V_S = 1.8V$ and $5V$, No Load, Output Low, $T_A = -40^\circ C$ to $+125^\circ C$			35	
PSRR	Power-supply rejection ratio	$V_S = 1.8V$ to $5V$, $T_A = -40^\circ C$ to $+125^\circ C$, (push-pull version)			177.8	$\mu V/V$
PSRR	Power-supply rejection ratio	$V_S = 1.8V$ to $5V$, $T_A = -40^\circ C$ to $+125^\circ C$, (push-pull version)	75	95		dB
PSRR	Power-supply rejection ratio	$V_S = 1.8V$ to $5V$, $T_A = -40^\circ C$ to $+125^\circ C$, (open drain version)			100	$\mu V/V$
PSRR	Power-supply rejection ratio	$V_S = 1.8V$ to $5V$, $T_A = -40^\circ C$ to $+125^\circ C$, (open drain version)	80	95		dB
INPUT BIAS CURRENT						
I_B	Input bias current	$V_{CM} = V_S/2$		5		pA
I_{OS}	Input offset current	$V_{CM} = V_S/2$		1		pA
INPUT CAPACITANCE						
C_{ID}	Input Capacitance, Differential	$V_{CM} = V_S/2$		2		pF
C_{IC}	Input Capacitance, Common Mode	$V_{CM} = V_S/2$		3		pF
INPUT VOLTAGE RANGE						
$V_{CM-Range}$	Common-mode voltage range	$V_S = 1.8V$ and $5V$, $T_A = -40^\circ C$ to $+125^\circ C$	$(V-) - 0.2$		$(V+) + 0.2$	V
CMRR	Common-mode rejection ratio	$V_S = 5V$, $(V-) - 0.2V < V_{CM} < (V+) + 0.2V$, $T_A = -40^\circ C$ to $+125^\circ C$	60	70		dB
CMRR	Common-mode rejection ratio	$V_S = 1.8V$, $(V-) - 0.2V < V_{CM} < (V+) + 0.2V$, $T_A = -40^\circ C$ to $+125^\circ C$	50	60		dB
OPEN-LOOP GAIN						
A_{VD}	Large signal differential voltage amplification	For open-drain version only	50	200		V/mV
OUTPUT						
V_{OL}	Voltage swing from $(V-)$	$I_{SINK} = 4mA$, $T_A = 25^\circ C$		75	125	mV
V_{OL}	Voltage swing from $(V-)$	$I_{SINK} = 4mA$, $T_A = -40^\circ C$ to $+125^\circ C$			175	mV
V_{OH}	Voltage swing from $(V+)$	$I_{SOURCE} = 4mA$, $T_A = 25^\circ C$ (push-pull only)		75	125	mV
V_{OH}	Voltage swing from $(V+)$	$I_{SOURCE} = 4mA$, $T_A = -40^\circ C$ to $+125^\circ C$ (push-pull only)			175	mV
I_{LKG}	Open-drain output leakage current	$V_{PULLUP} = (V+)$, $T_A = 25^\circ C$ (open drain only)		100		pA
I_{SC}	Short-circuit current	$V_S = 5V$, Sinking	90	100		mA
I_{SC}	Short-circuit current	$V_S = 5V$, Sourcing (push-pull only)	90	100		mA

5.12 Switching Characteristics, TLV90x4-Q1

For V_S (Total Supply Voltage) = $(V+) - (V-)$ = 5V, $V_{CM} = V_S / 2$, $C_L = 15\text{pF}$ at $T_A = 25^\circ\text{C}$ (Unless otherwise noted)

PARAMETER		TEST CONDITIONS	MIN	TYP	MAX	UNIT
OUTPUT						
T_{PD-HL}	Propagation delay time, high-to-low	$V_{ID} = -100\text{mV}$; Delay from mid-point of input to mid-point of output ($R_P = 2.5\text{K}\Omega$ for open drain only)		100		ns
T_{PD-LH}	Propagation delay time, low-to-high	$V_{ID} = 100\text{mV}$; Delay from mid-point of input to mid-point of output (for push-pull only)		115		ns
T_{PD-LH}	Propagation delay time, low-to-high	$V_{ID} = 100\text{mV}$; Delay from mid-point of input to mid-point of output ($R_P = 2.5\text{K}\Omega$ for open drain only)		150		ns
T_{FALL}	5V Output Fall Time, 80% to 20%	$V_{ID} = -100\text{mV}$		3		ns
T_{RISE}	5V Output Rise Time, 20% to 80%	$V_{ID} = 100\text{mV}$, for push-pull only		3		ns
F_{TOGGLE}	5V, Toggle Frequency	$V_{ID} = 100\text{mV}$ ($R_P = 2.5\text{K}\Omega$ for open drain only)		3		MHz
POWER ON TIME						
P_{ON}	Power on-time	$V_S = 1.8\text{V}$ and 5V , $V_{CM} = (V-)$, $V_{ID} = -0.1\text{V}$, $V_{PULL-UP} = V_S / 2$, Delay from $V_S / 2$ to $V_{OUT} = 0.1 \times V_S / 2$ ($R_P = 2.5\text{K}\Omega$ for open drain only)		30		μs

5.13 Typical Characteristics

$T_A = 25^\circ\text{C}$, $V_S = 5\text{V}$, $R_{\text{PULLUP}} = 2.5\text{k}$, $C_L = 15\text{pF}$, $V_{\text{CM}} = 0\text{V}$, $V_{\text{UNDERDRIVE}} = 100\text{mV}$, $V_{\text{OVERDRIVE}} = 100\text{mV}$ unless otherwise noted.

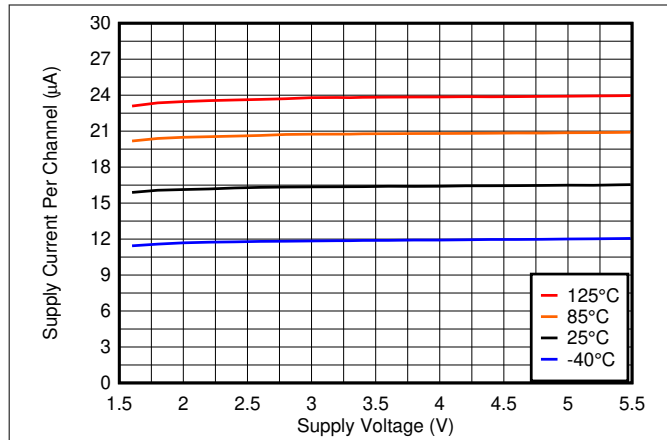

Figure 5-1. Supply Current vs. Supply Voltage

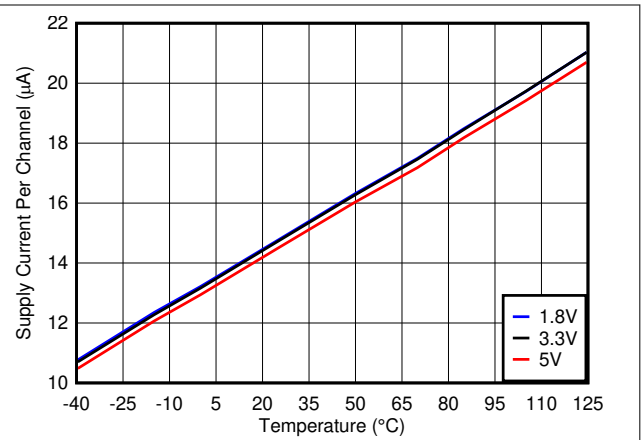

Figure 5-2. Supply Current vs. Temperature

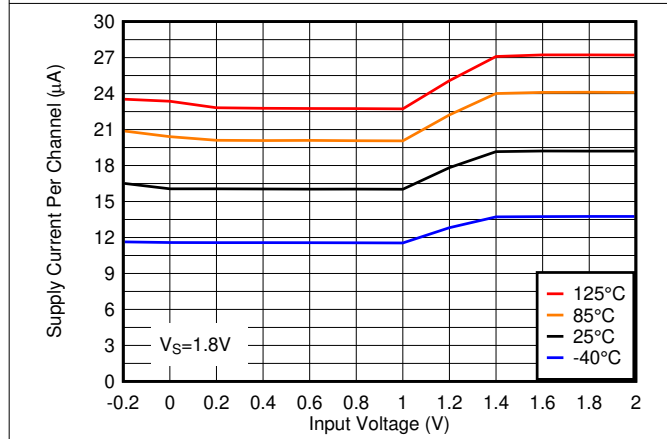

Figure 5-3. Supply Current vs. Input Voltage, 1.8V

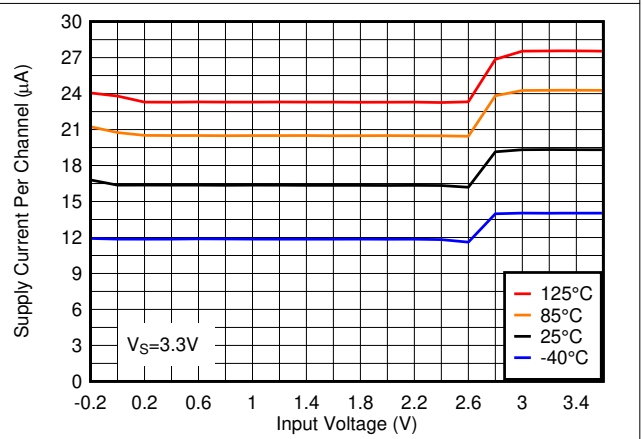

Figure 5-4. Supply Current vs. Input Voltage, 3.3V

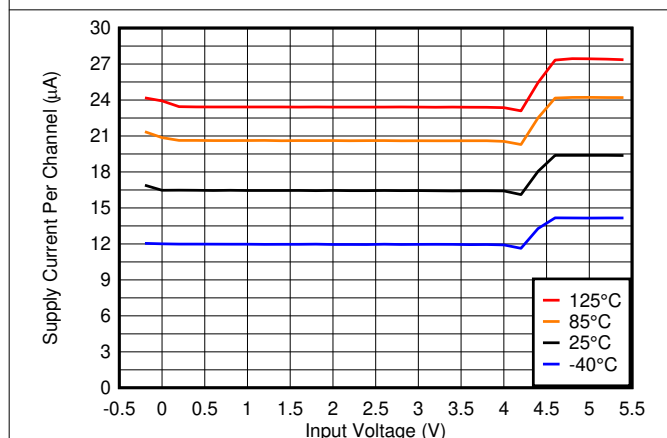

Figure 5-5. Supply Current vs. Input Voltage, 5V

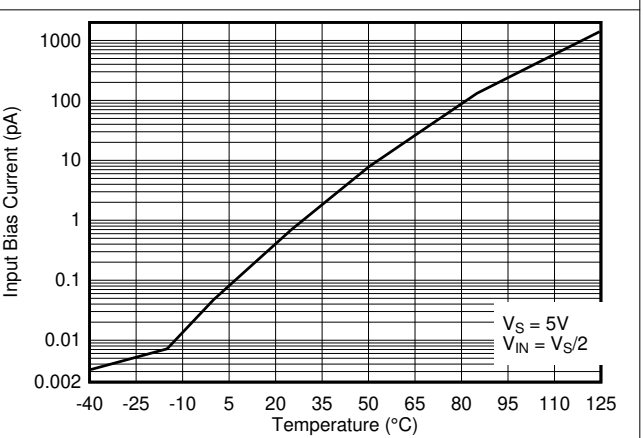

Figure 5-6. Input Bias Current vs. Temperature

5.13 Typical Characteristics (continued)

$T_A = 25^\circ\text{C}$, $V_S = 5\text{V}$, $R_{\text{PULLUP}} = 2.5\text{k}$, $C_L = 15\text{pF}$, $V_{\text{CM}} = 0\text{V}$, $V_{\text{UNDERDRIVE}} = 100\text{mV}$, $V_{\text{OVERDRIVE}} = 100\text{mV}$ unless otherwise noted.

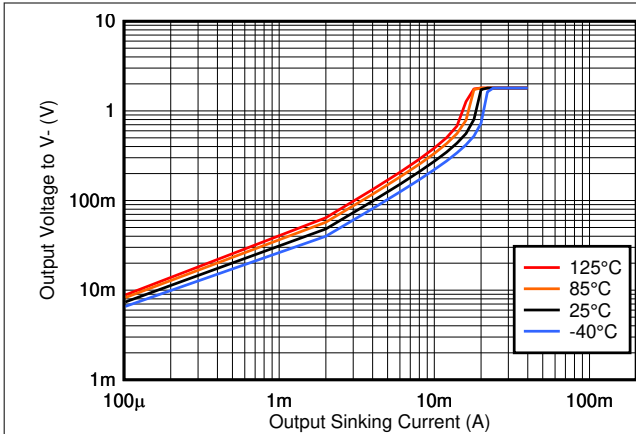

Figure 5-7. Output Sinking Current vs. Output Voltage, 1.8V

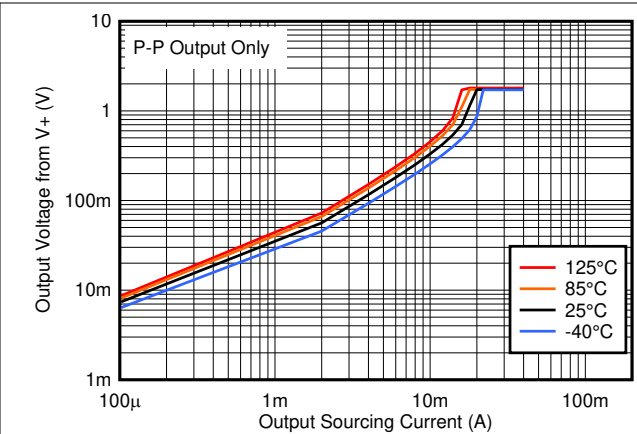

Figure 5-8. Output Sourcing Current vs. Output Voltage, 1.8V

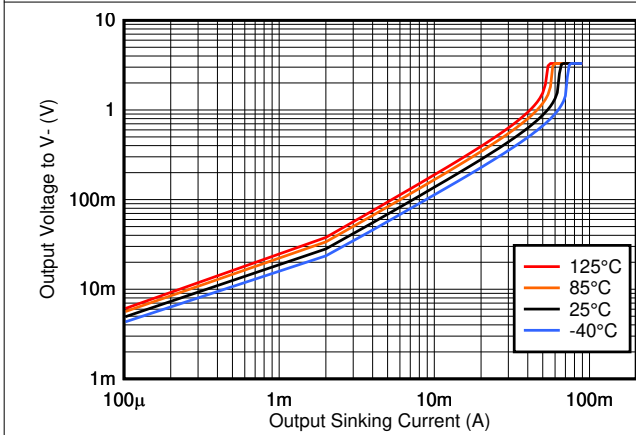

Figure 5-9. Output Sinking Current vs. Output Voltage, 3.3V

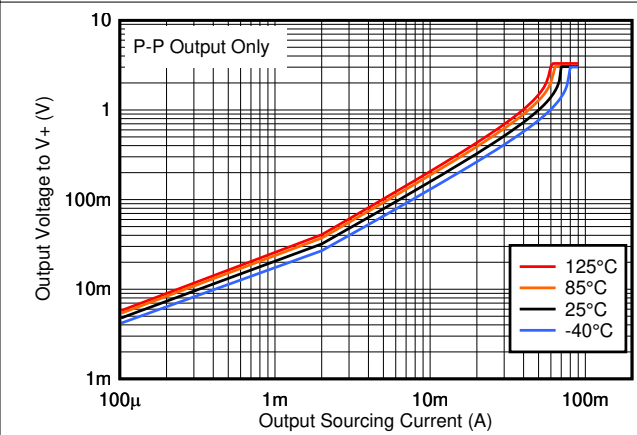

Figure 5-10. Output Sourcing Current vs. Output Voltage, 3.3V

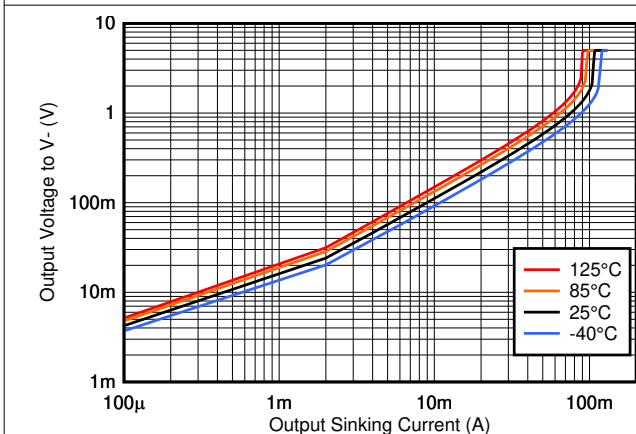

Figure 5-11. Output Sinking Current vs. Output Voltage, 5V

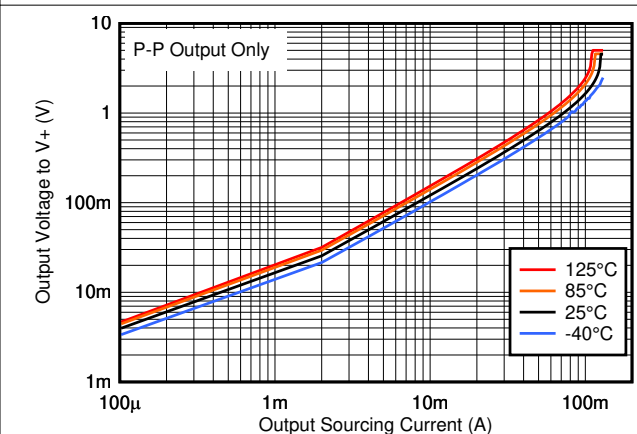

Figure 5-12. Output Sourcing Current vs. Output Voltage, 5V

5.13 Typical Characteristics (continued)

$T_A = 25^\circ\text{C}$, $V_S = 5\text{V}$, $R_{PULLUP} = 2.5\text{k}$, $C_L = 15\text{pF}$, $V_{CM} = 0\text{V}$, $V_{UNDERDRIVE} = 100\text{mV}$, $V_{OVERDRIVE} = 100\text{mV}$ unless otherwise noted.

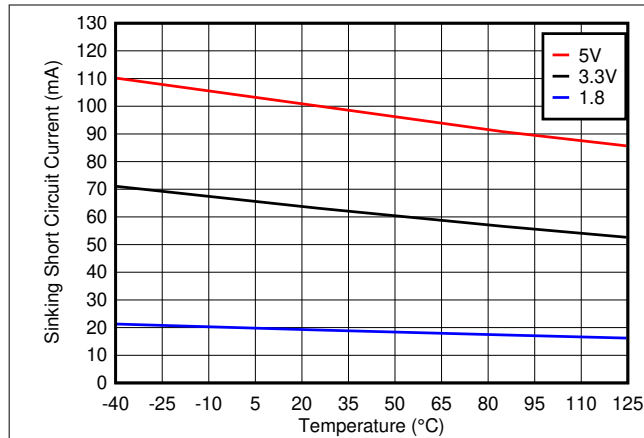

Figure 5-13. Sinking Short Circuit Current vs. Temperature

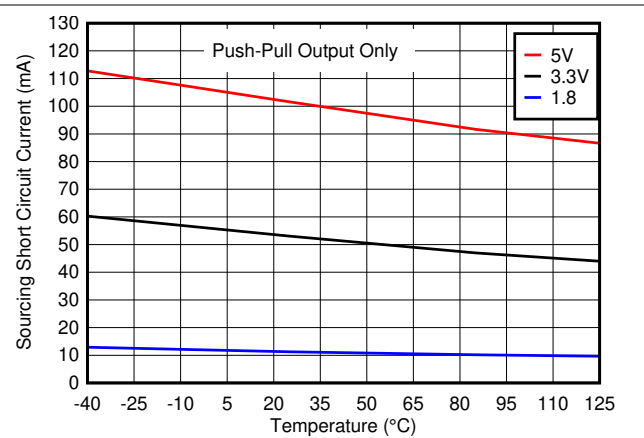

Figure 5-14. Sourcing Short Circuit Current vs. Temperature

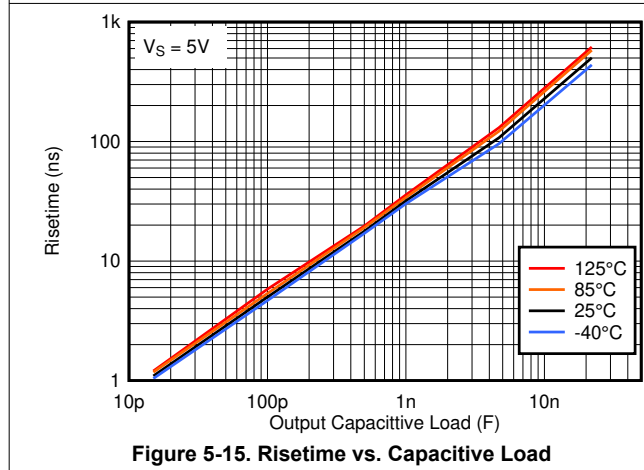

Figure 5-15. Risetime vs. Capacitive Load

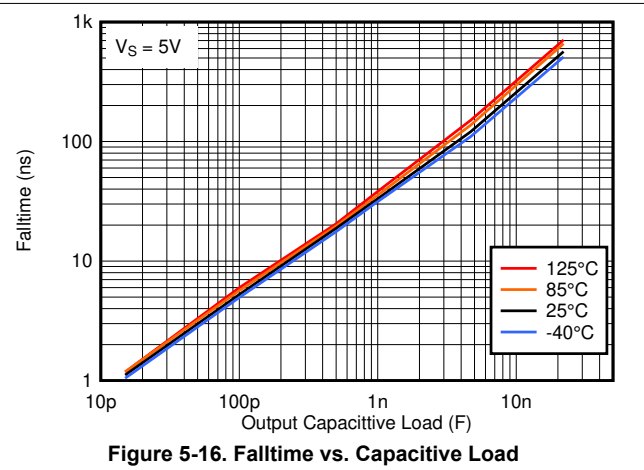

Figure 5-16. Falltime vs. Capacitive Load

5.13 Typical Characteristics (continued)

$T_A = 25^\circ\text{C}$, $V_S = 5\text{V}$, $R_{\text{PULLUP}} = 2.5\text{k}$, $C_L = 15\text{pF}$, $V_{\text{CM}} = 0\text{V}$, $V_{\text{UNDERDRIVE}} = 100\text{mV}$, $V_{\text{OVERDRIVE}} = 100\text{mV}$ unless otherwise noted.

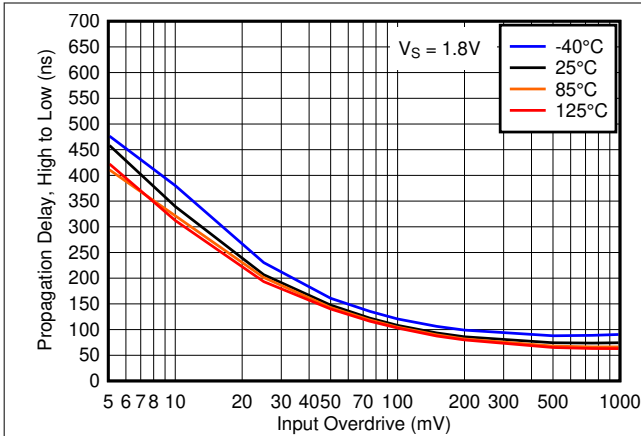

Figure 5-17. Propagation Delay, High to Low, 1.8V

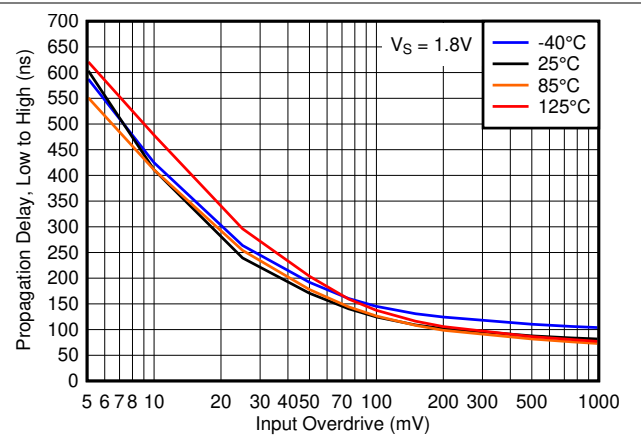

Figure 5-18. Propagation Delay, Low to High, 1.8V

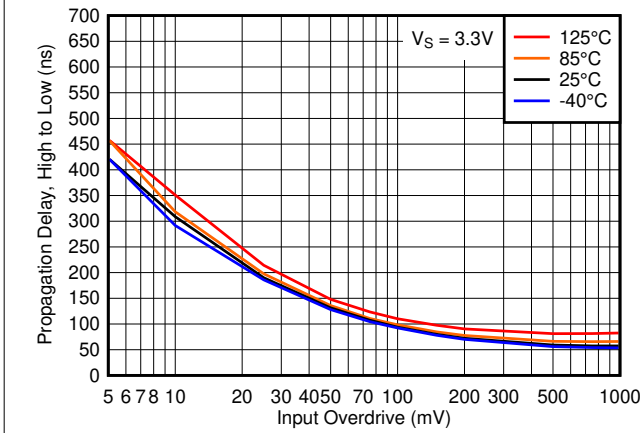

Figure 5-19. Propagation Delay, High to Low, 3.3V

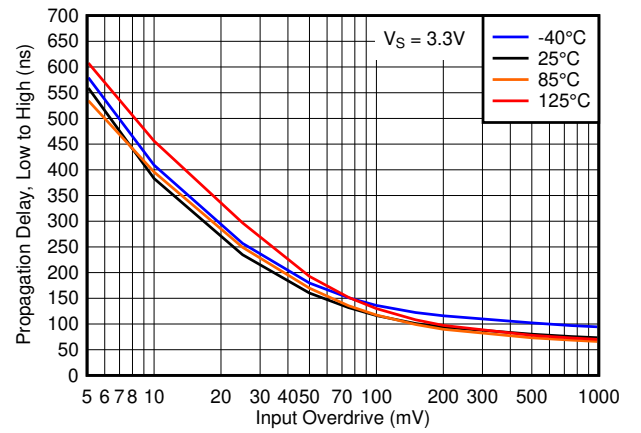

Figure 5-20. Propagation Delay, Low to High, 3.3V

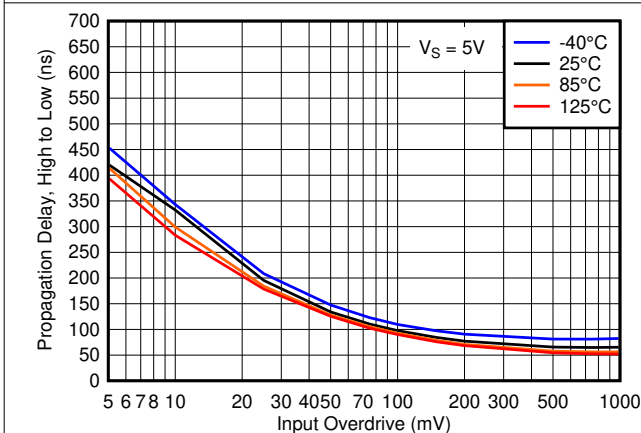

Figure 5-21. Propagation Delay, High to Low, 5V

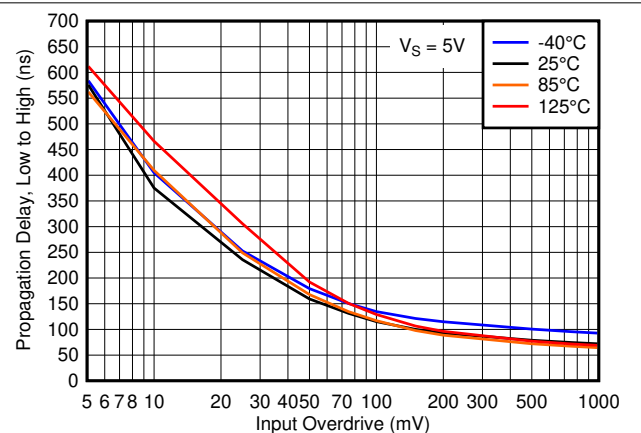

Figure 5-22. Propagation Delay, Low to High, 5V

5.13 Typical Characteristics (continued)

$T_A = 25^\circ\text{C}$, $V_S = 5\text{V}$, $R_{\text{PULLUP}} = 2.5\text{k}$, $C_L = 15\text{pF}$, $V_{\text{CM}} = 0\text{V}$, $V_{\text{UNDERDRIVE}} = 100\text{mV}$, $V_{\text{OVERDRIVE}} = 100\text{mV}$ unless otherwise noted.

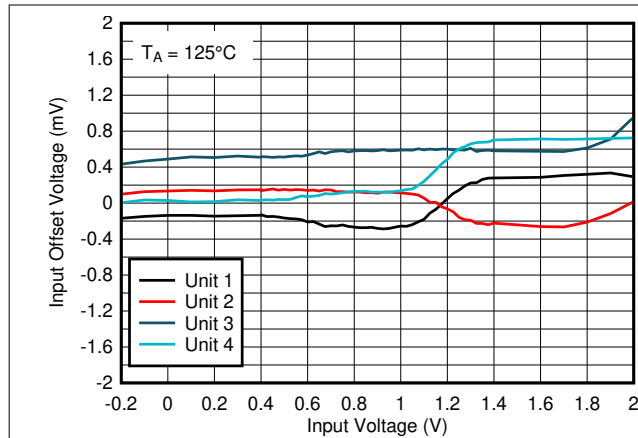

Figure 5-23. Offset Voltage vs. Input Voltage at 125°C, 1.8V

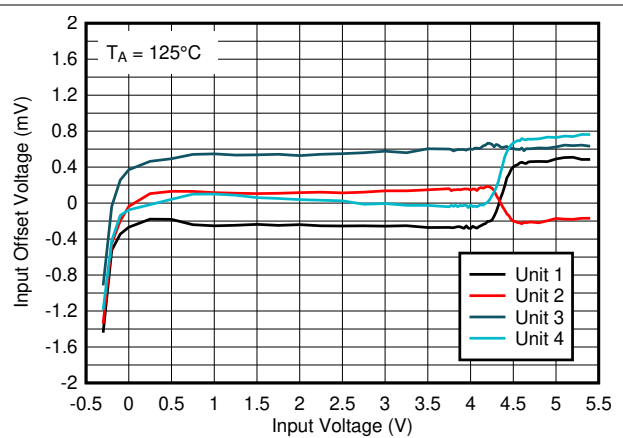

Figure 5-24. Offset Voltage vs. Input Voltage at 125°C, 5V

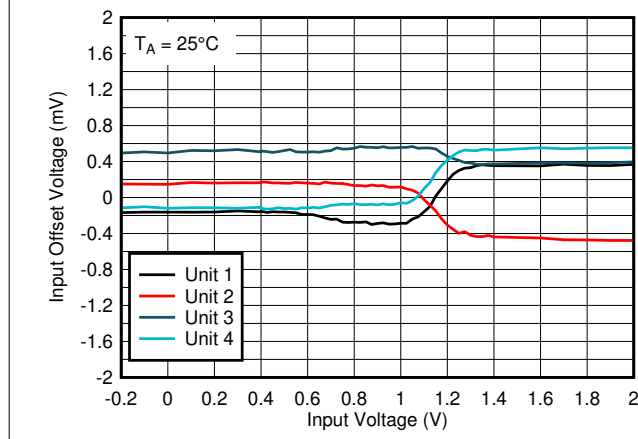

Figure 5-25. Offset Voltage vs. Input Voltage at 25°C, 1.8V

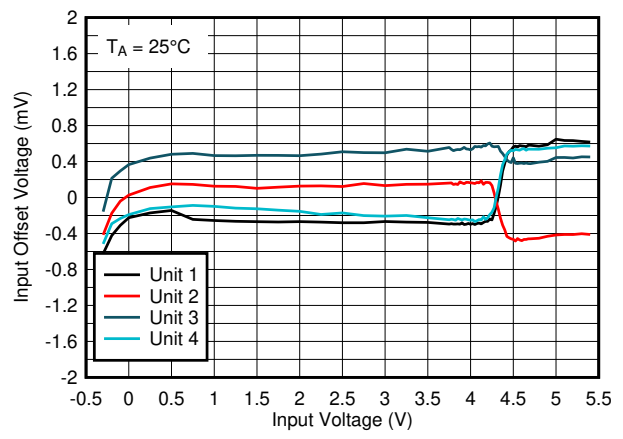

Figure 5-26. Offset Voltage vs. Input Voltage at 25°C, 5V

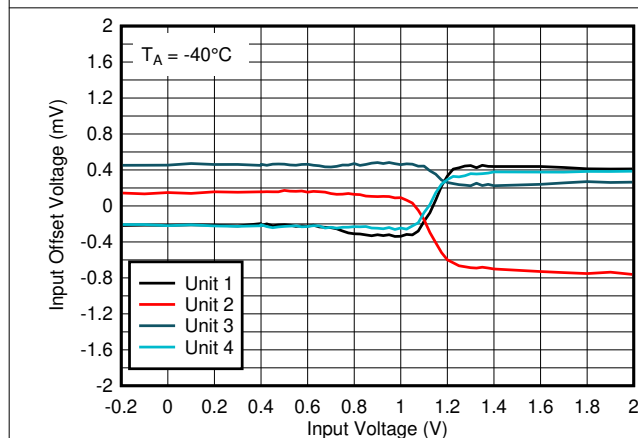

Figure 5-27. Offset Voltage vs. Input Voltage at -40°C, 1.8V

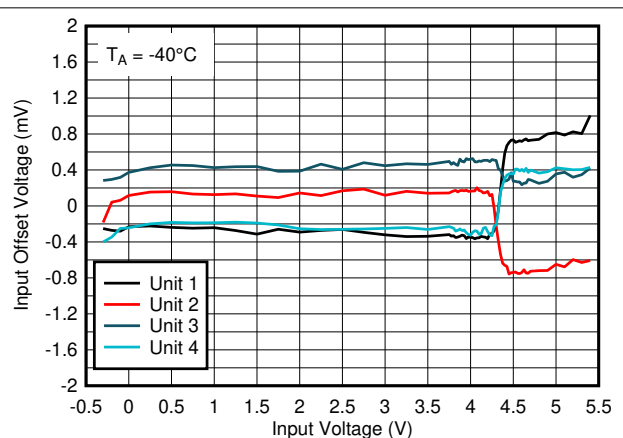

Figure 5-28. Offset Voltage vs. Input Voltage at -40°C, 5V

5.13 Typical Characteristics (continued)

$T_A = 25^\circ\text{C}$, $V_S = 5\text{V}$, $R_{\text{PULLUP}} = 2.5\text{k}$, $C_L = 15\text{pF}$, $V_{\text{CM}} = 0\text{V}$, $V_{\text{UNDERDRIVE}} = 100\text{mV}$, $V_{\text{OVERDRIVE}} = 100\text{mV}$ unless otherwise noted.

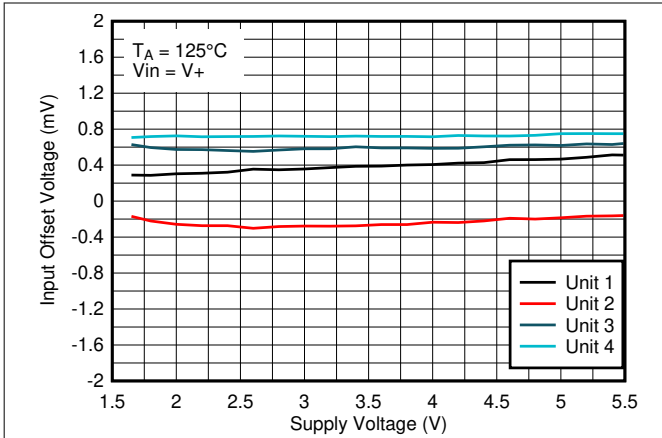

Figure 5-29. Offset Voltage vs. Supply Voltage at 125°C , $V_{\text{IN}}=V_+$

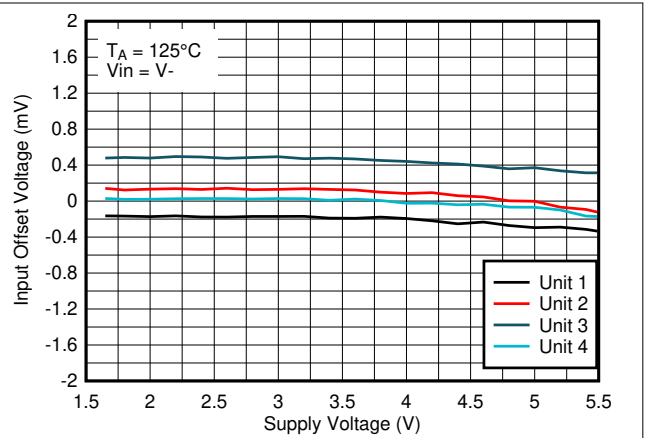

Figure 5-30. Offset Voltage vs. Supply Voltage at 125°C , $V_{\text{IN}}=V_-$

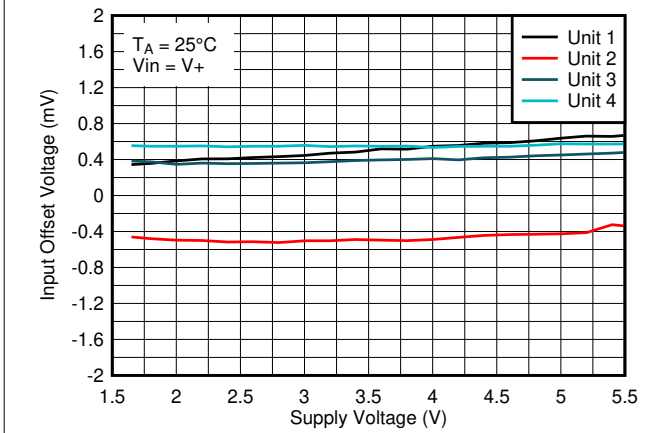

Figure 5-31. Offset Voltage vs. Supply Voltage at 25°C , $V_{\text{IN}}=V_+$

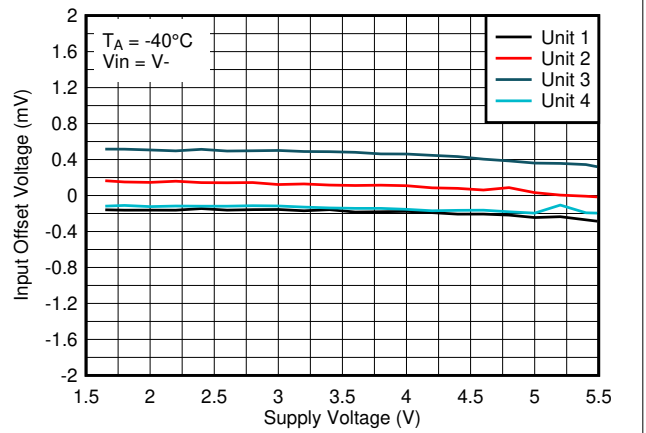

Figure 5-32. Offset Voltage vs. Supply Voltage at 25°C , $V_{\text{IN}}=V_-$

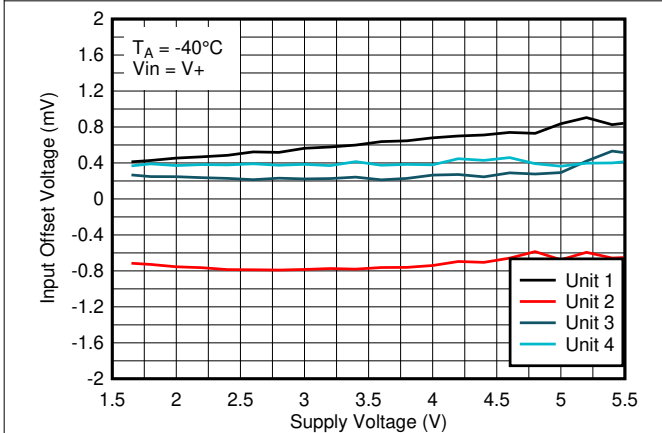

Figure 5-33. Offset Voltage vs. Supply Voltage at -40°C , $V_{\text{IN}}=V_+$

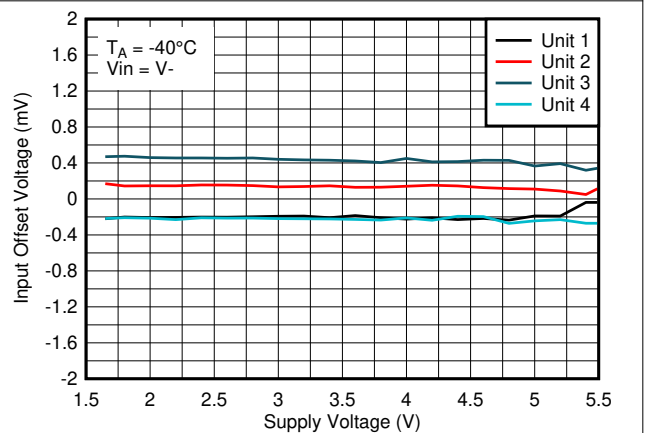

Figure 5-34. Offset Voltage vs. Supply Voltage at -40°C , $V_{\text{IN}}=V_-$

6 Detailed Description

6.1 Overview

The TLV902x-Q1 and TLV903x-Q1 devices are dual-channel, micro-power comparators with push-pull and open-drain outputs and low input offset voltage. Operating down to 1.65V while only consuming only 16µA per channel, the TLV902x-Q1 and TLV903x-Q1 are designed for portable, automotive and industrial applications. An internal power-on reset circuit makes sure that the output remains in a known state during power-up and power-down while fail-safe inputs can tolerate input transients without damage or false outputs.

6.2 Functional Block Diagram

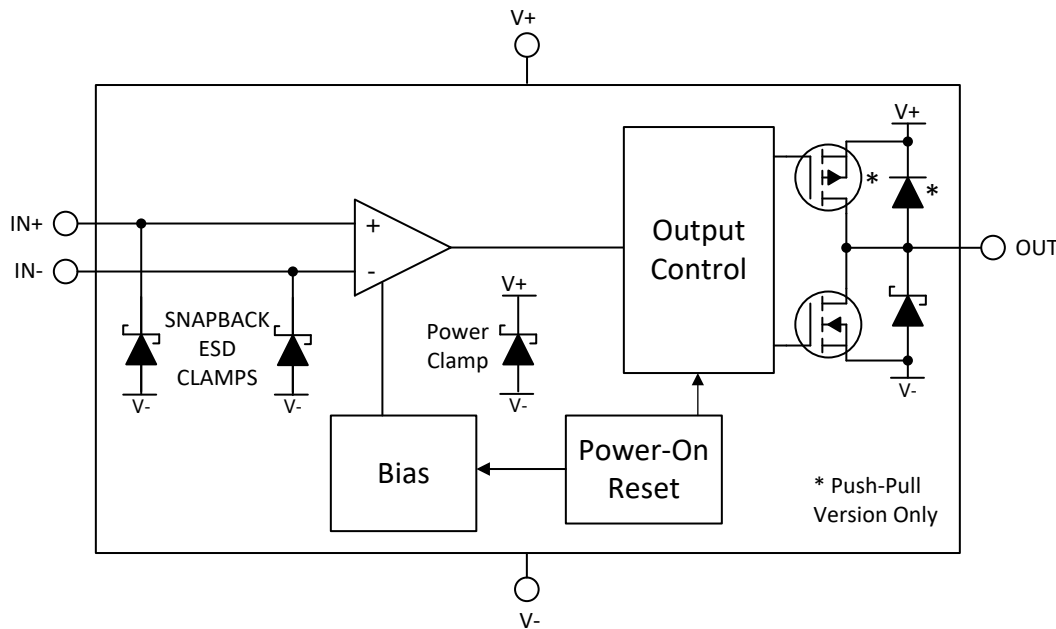

6.3 Feature Description

The TLV902x-Q1 (open-drain output) and TLV903x-Q1 (push-pull output) devices are micro-power comparators that have low input offset voltages and are capable of operating at low voltages. The TLV90xx-Q1 family feature a rail-to-rail input stage capable of operating up to 200mV beyond the power supply rails. The comparators also feature push-pull and open-drain output stage options and Power-on Reset for known start-up conditions.

6.4 Device Functional Modes

6.4.1 Outputs

6.4.1.1 TLV9022-Q1 and TLV9024-Q1 Open Drain Output

The TLV902x-Q1 features an open-drain (also commonly called open collector) sinking-only output stage enabling the output logic levels to be pulled up to an external voltage from 0 V up to 5.5V, independent of the comparator supply voltage (V_S). The open-drain output also allows logical OR'ing of multiple open drain outputs and logic level translation. TI recommends setting the pull-up resistor current to between 100µA and 1mA. Lower pull-up resistor values will help increase the rising edge risetime, but at the expense of increasing V_{OL} and higher power dissipation. The risetime will be dependant on the time constant of the total pull-up resistance and total load capacitance. Large value pull-up resistors (>1 MΩ) will create an exponential rising edge due to the RC time constant and increase the risetime.

Unused open drain outputs must be left floating, or can be tied to the V- pin if floating pins are not allowed. While an individual output can typically sink up to 125 mA, the total combined current for all channels must be less than 200mA.

6.4.1.2 TLV9032-Q1 and TLV9034-Q1 Push-Pull Output

The TLV903x-Q1 features a push-pull output stage capable of both sinking and sourcing current. This allows driving loads such as LED's and MOSFET gates, as well as eliminating the need for a power-wasting external pull-up resistor. The push-pull output must never be connected to another output.

Unused push-pull outputs must be left floating, and never tied to a supply, ground, or another output. While an individual output can typically sink and source up to 100mA, the total combined current for all channels must be less than 200mA.

6.4.2 Power-On Reset (POR)

The TLV90xx-Q1 has an internal Power-on-Reset (POR) circuit for known start-up or power-down conditions. While the power supply (V_S) is ramping up or ramping down, the POR circuitry will be activated for up to 30 μ s after the minimum supply voltage threshold of 1.5V is crossed, or immediately when the supply voltage drops below 1.5V. When the supply voltage is equal to or greater than the minimum supply voltage, and after the delay period, the comparator output reflects the state of the differential input (V_{ID}).

The POR circuit will keep the output high impedance (HI-Z) during the POR period (t_{on}).

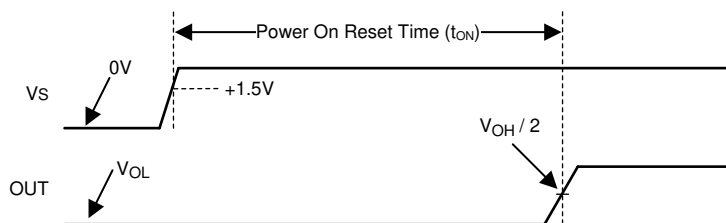

Figure 6-1. Power-On Reset Timing Diagram

Note that it the nature of an open collector output that the output will rise with the pull-up voltage during the POR period.

For the TL903x-Q1 push-pull output devices, the output is "floating" during the POR period. A light pull-up (to $V+$) or pull-down (to $V-$) resistor can be used to pre-bias the output condition to prevent the output from floating. If output high is the desired start-up condition, then use the open collector TL902x-Q1, since a pull-up resistor is already required.

6.4.3 Inputs

6.4.3.1 Rail to Rail Input

The TLV90xx-Q1 input voltage range extends from 200mV below $V-$ to 200mV above $V+$. The differential input voltage (V_{ID}) can be any voltage within these limits. No phase-inversion of the comparator output will occur when the input pins exceed $V+$ or $V-$.

6.4.3.2 Fault Tolerant Inputs

The TLV90xx-Q1 inputs are fault tolerant up to 5.5V independent of V_S . Fault tolerant is defined as maintaining the same high input impedance when V_S is unpowered or within the recommended operating ranges.

The fault tolerant inputs can be any value between 0 V and 5.5V, even while V_S is zero or ramping up or down. This feature avoids power sequencing issues as long as the input voltage range and supply voltage are within the specified ranges. This is possible since the inputs are not clamped to $V+$ and the input current maintains its value even when a higher voltage is applied to the inputs.

As long as one of the input pins remains within the valid input range, and the supply voltage is valid and not in POR, the output state will be correct.

The following is a summary of input voltage excursions and their outcomes:

1. When both IN- and IN+ are within the specified input voltage range:

- a. If IN- is higher than IN+ and the offset voltage, the output is low.
- b. If IN- is lower than IN+ and the offset voltage, the output is high.
2. When IN- is higher than the specified input voltage range and IN+ is within the specified voltage range, the output is low.
3. When IN+ is higher than the specified input voltage range and IN- is within the specified input voltage range, the output is high.
4. When IN- and IN+ are both outside the specified input voltage range, the output is **indeterminate** (random).
Do not operate in this region.

Even with the fault tolerant feature, TI *strongly* recommends keeping the inputs within the specified input voltage range during normal system operation to maintain datasheet specifications. Operating outside the specified input range can cause changes in specifications such as propagation delay and input bias current, which can lead to unpredictable behavior.

6.4.3.3 Input Protection

The input bias current is typically 5pA for input voltages between V+ and V-. The comparator inputs are protected from reverse voltage by the internal ESD diodes connected to V-. As the input voltage goes under V-, or above the input Absolute Maximum ratings the protection diodes become forward biased and begin to conduct causing the input bias current to increase exponentially. Input bias current typically doubles for each 10°C temperature increase.

If the inputs are to be connected to a low impedance source, such as a power supply or buffered reference line, TI recommends adding a current-limiting resistor in series with the input to limit any transient currents should the clamps conduct. The current should be limited 10mA or less. This series resistance can be part of any resistive input dividers or networks.

6.4.4 ESD Protection

The TLV90xx-Q1 family incorporates internal ESD protection circuits on all pins. The inputs, and the open-drain output, use a proprietary "snapback" type ESD clamp from each pin to V-, which allows the pins to exceed the supply voltage (V+). While shown as Zener diodes, snapback "short" and go low impedance (like an SCR) when the threshold is exceeded, as opposed to clamping to a defined voltage like a Zener.

The TLV902x-Q1 open-drain output protection also consists of a ESD clamp between the output and V- to allow the output to be pulled above V+ to a maximum of 5.5V.

The TLV903x-Q1 push-pull output protection consists of a ESD clamp between the output and V-, but also includes a ESD diode clamp to V+, as the output must not exceed the supply rails.

If the inputs are to be connected to a low impedance source, such as a power supply or buffered reference line, TI recommends adding a current-limiting resistor in series with the input to limit any transient currents must the clamps conduct. The current must be limited 10mA or less. This series resistance can be part of any resistive input dividers or networks. TI does not specify the performance of the ESD clamps and external clamping must be added if the inputs or output could exceed the maximum ratings as part of normal operation.

6.4.5 Unused Inputs

If a channel is not to be used, DO NOT tie the inputs together. Due to the high equivalent bandwidth and low offset voltage, tying the inputs directly together can cause high frequency oscillations as the device triggers on it's own internal wideband noise. Instead, the inputs must be tied to any available voltage that resides within the specified input voltage range and provides a minimum of 50mV differential voltage. For example, one input can be grounded and the other input connected to a reference voltage, or even V+ as long as the input is directly connected to the V+ pin to avoid transients).

6.4.6 Hysteresis

The TLV90xx-Q1 family does not have internal hysteresis. Due to the wide effective bandwidth and low input offset voltage, it is possible for the output to "chatter" (oscillate) when the absolute differential voltage near zero as the comparator triggers on it's own internal wideband noise. This is normal comparator behavior and

is expected. TI recommends that the user add external hysteresis if slow moving signals are expected. See [Section 7.1.2](#) in the following section.

7 Application and Implementation

Note

Information in the following applications sections is not part of the TI component specification, and TI does not warrant its accuracy or completeness. TI's customers are responsible for determining suitability of components for their purposes. Customers should validate and test their design implementation to confirm system functionality.

7.1 Application Information

7.1.1 Basic Comparator Definitions

7.1.1.1 Operation

The basic comparator compares the input voltage (V_{IN}) on one input to a reference voltage (V_{REF}) on the other input. In the [Figure 7-1](#) example below, if V_{IN} is less than V_{REF} , the output voltage (V_O) is logic low (V_{OL}). If V_{IN} is greater than V_{REF} , the output voltage (V_O) is at logic high (V_{OH}). [Table 7-1](#) summarizes the output conditions. The output logic can be inverted by simply swapping the input pins.

Table 7-1. Output Conditions

Inputs Condition	Output
$IN+ > IN-$	HIGH (V_{OH})
$IN+ = IN-$	Indeterminate (chatters - see Hysteresis)
$IN+ < IN-$	LOW (V_{OL})

7.1.1.2 Propagation Delay

There is a delay between from when the input crosses the reference voltage and the output responds. This is called the Propagation Delay. Propagation delay can be different between high-to low and low-to-high input transitions. This is shown as t_{pLH} and t_{pHL} in [Figure 7-1](#) and is measured from the mid-point of the input to the midpoint of the output.

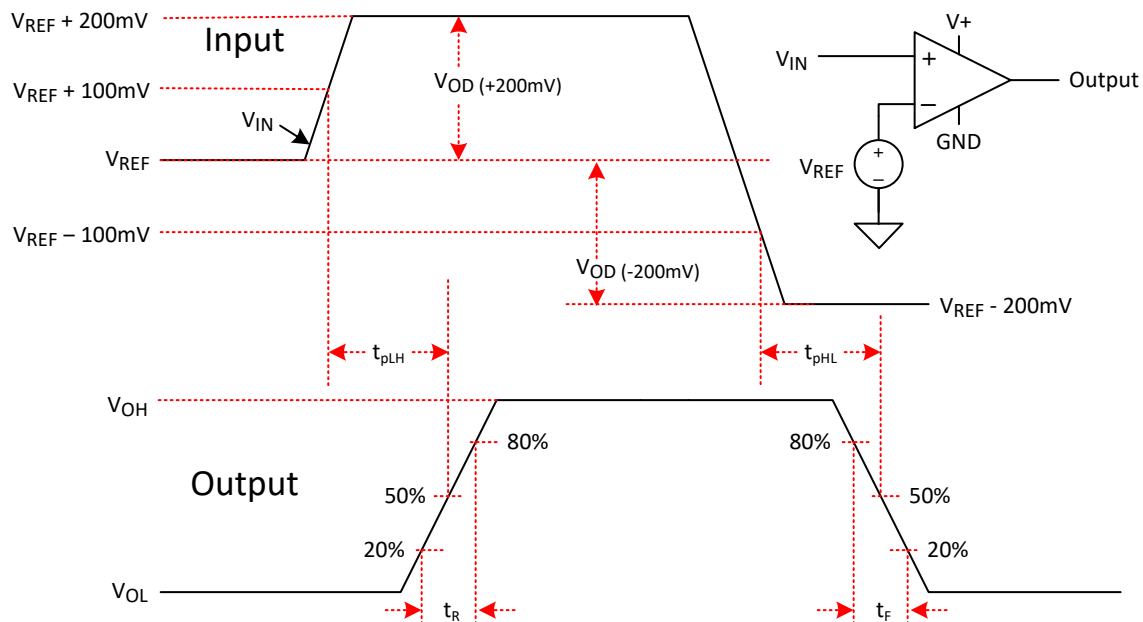

Figure 7-1. Comparator Timing Diagram

7.1.1.3 Overdrive Voltage

The overdrive voltage, V_{OD} , is the amount of input voltage beyond the reference voltage (and not the total input peak-to-peak voltage). The overdrive voltage is 100mV as shown in the [Figure 7-1](#) example. The overdrive voltage can influence the propagation delay (t_p). The smaller the overdrive voltage, the longer the propagation delay, particularly when $<100\text{mV}$. If the fastest speeds are desired, it is recommended to apply the highest amount of overdrive possible.

The risetime (t_r) and falltime (t_f) is the time from the 20% and 80% points of the output waveform.

7.1.2 Hysteresis

The basic comparator configuration may oscillate or produce a noisy "chatter" output if the applied differential input voltage is near the comparator's offset voltage. This usually occurs when the input signal is moving very slowly across the switching threshold of the comparator.

This problem can be prevented by the addition of hysteresis or positive feedback.

The hysteresis transfer curve is shown in [Figure 7-2](#). This curve is a function of three components: V_{TH} , V_{OS} , and V_{HYST} :

- V_{TH} is the actual set voltage or threshold trip voltage.
- V_{OS} is the internal offset voltage between V_{IN+} and V_{IN-} . This voltage is added to V_{TH} to form the actual trip point at which the comparator must respond to change output states.
- V_{HYST} is the hysteresis (or trip window) that is designed to reduce comparator sensitivity to noise.

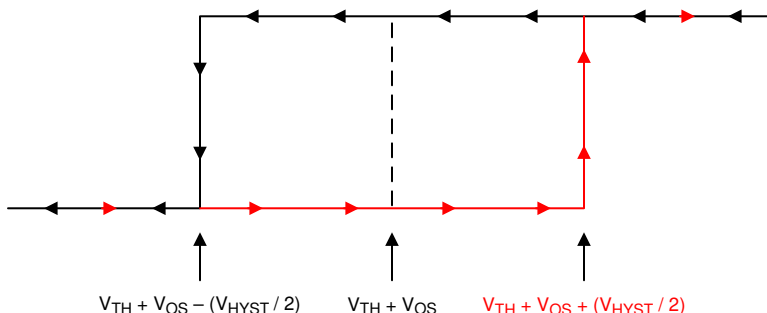

Figure 7-2. Hysteresis Transfer Curve

For more information, please see Application Note SBOA219 "[Comparator with and without hysteresis circuit](#)".

7.1.2.1 Inverting Comparator With Hysteresis

The inverting comparator with hysteresis requires a three-resistor network that is referenced to the comparator supply voltage ($V+$), as shown in [Figure 7-3](#).

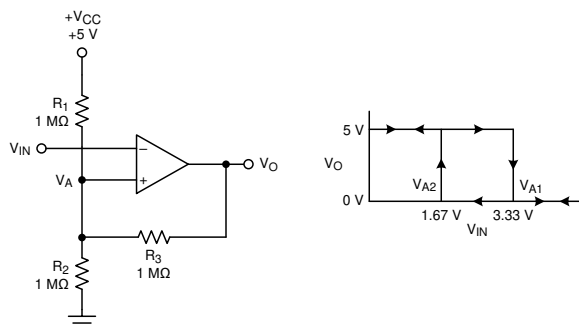

Figure 7-3. TLV903x-Q1 in an Inverting Configuration With Hysteresis

The equivalent resistor networks when the output is high and low are shown in [Figure 7-3](#).

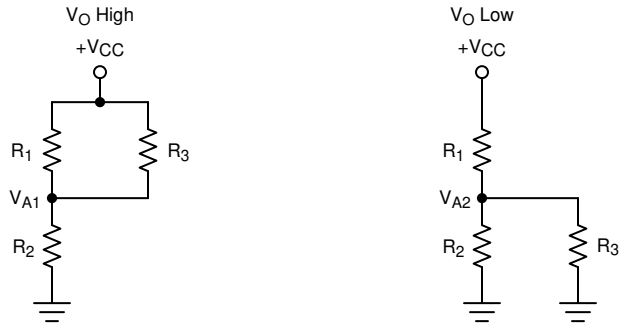

Figure 7-4. Inverting Configuration Resistor Equivalent Networks

When V_{IN} is less than V_A , the output voltage is high (for simplicity, assume V_O switches as high as V_{CC}). The three network resistors can be represented as $R1 \parallel R3$ in series with $R2$, as shown in [Figure 7-4](#).

[Equation 1](#) below defines the high-to-low trip voltage (V_{A1}).

$$V_{A1} = V_{CC} \times \frac{R2}{(R1 \parallel R3) + R2} \quad (1)$$

When V_{IN} is greater than V_A , the output voltage is low. In this case, the three network resistors can be presented as $R2 \parallel R3$ in series with $R1$, as shown in [Equation 2](#).

Use [Equation 2](#) to define the low to high trip voltage (V_{A2}).

$$V_{A2} = V_{CC} \times \frac{R2 \parallel R3}{R1 + (R2 \parallel R3)} \quad (2)$$

[Equation 3](#) defines the total hysteresis provided by the network.

$$\Delta V_A = V_{A1} - V_{A2} \quad (3)$$

7.1.2.2 Non-Inverting Comparator With Hysteresis

A noninverting comparator with hysteresis requires a two-resistor network and a voltage reference (V_{REF}) at the inverting input, as shown in [Figure 7-5](#),

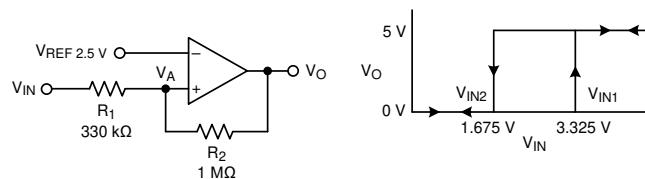

Figure 7-5. TLV903x-Q1 in a Non-Inverting Configuration With Hysteresis

The equivalent resistor networks when the output is high and low are shown in [Figure 7-6](#).

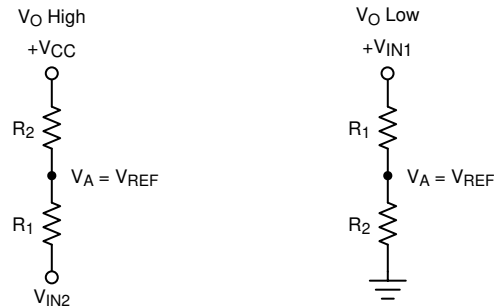

Figure 7-6. Non-Inverting Configuration Resistor Networks

When V_{IN} is less than V_{REF} , the output is low. For the output to switch from low to high, V_{IN} must rise above the V_{IN1} threshold. Use [Equation 4](#) to calculate V_{IN1} .

$$V_{IN1} = R1 \times \frac{V_{REF}}{R2} + V_{REF} \quad (4)$$

When V_{IN} is greater than V_{REF} , the output is high. For the comparator to switch back to a low state, V_{IN} must drop below V_{IN2} . Use [Equation 5](#) to calculate V_{IN2} .

$$V_{IN2} = \frac{V_{REF} (R1 + R2) - V_{CC} \times R1}{R2} \quad (5)$$

The hysteresis of this circuit is the difference between V_{IN1} and V_{IN2} , as shown in [Equation 6](#).

$$\Delta V_{IN} = V_{CC} \times \frac{R1}{R2} \quad (6)$$

For more information, please see Application Notes SNOA997 "[Inverting comparator with hysteresis circuit](#)" and SBOA313 "[Non-Inverting Comparator With Hysteresis Circuit](#)".

7.1.2.3 Inverting and Non-Inverting Hysteresis Using Open-Drain Output

It is also possible to use an open drain output device, such as the TLV902x-Q1, but the output pull-up resistor must also be taken into account in the calculations. The pull-up resistor is seen in series with the feedback resistor when the output is high. Thus, the feedback resistor is actually seen as $R2 + R_{PULLUP}$. TI recommends that the pull-up resistor be at least 10 times less than the feedback resistor value.

7.2 Typical Applications

7.2.1 Window Comparator

Window comparators are commonly used to detect undervoltage and overvoltage conditions. [Figure 7-7](#) shows a simple window comparator circuit. Window comparators require open drain outputs (TLV902x-Q1) if the outputs are directly connected together.

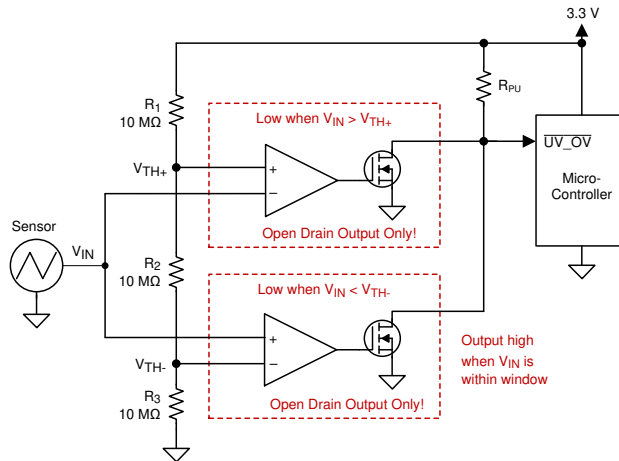

Figure 7-7. Window Comparator

7.2.1.1 Design Requirements

For this design, follow these design requirements:

- Alert (logic low output) when an input signal is less than 1.1V
- Alert (logic low output) when an input signal is greater than 2.2V
- Alert signal is active low
- Operate from a 3.3V power supply

7.2.1.2 Detailed Design Procedure

Configure the circuit as shown in [Figure 7-7](#). Connect V_{CC} to a 3.3V power supply and V_{EE} to ground. Make R1, R2 and R3 each 10M Ω resistors. These three resistors are used to create the positive and negative thresholds for the window comparator (V_{TH+} and V_{TH-}).

With each resistor being equal, V_{TH+} is 2.2V and V_{TH-} is 1.1V. Large resistor values such as 10M Ω are used to minimize power consumption. The resistor values can be recalculated to provide the desired trip point values.

The sensor output voltage is applied to the inverting and noninverting inputs of the two comparators. Using two open-drain output comparators allows the two comparator outputs to be Wire-OR'ed together.

The respective comparator outputs will be low when the sensor is less than 1.1V or greater than 2.2V. The respective comparator outputs will be high when the sensor is in the range of 1.1V to 2.2V (within the "window"), as shown in [Figure 7-8](#).

7.2.1.3 Application Curve

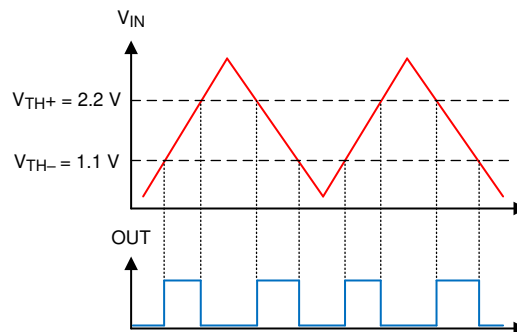

Figure 7-8. Window Comparator Results

For more information, please see Application note SBOA221 "[Window comparator circuit](#)".

7.2.2 Square-Wave Oscillator

Square-wave oscillator can be used as low cost timing reference or system supervisory clock source. A push-pull output (TLV903x-Q1) is recommended for best symmetry.

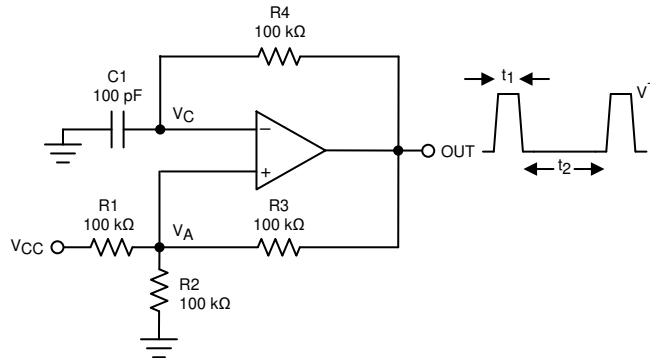

Figure 7-9. Square-Wave Oscillator

7.2.2.1 Design Requirements

The square-wave period is determined by the RC time constant of the capacitor C_1 and resistor R_4 . The maximum frequency is limited by propagation delay of the device and the capacitance load at the output. The low input bias current allows a lower capacitor value and larger resistor value combination for a given oscillator frequency, which may help to reduce BOM cost and board space. R_4 must be over several kilo-ohms to minimize loading the output.

7.2.2.2 Detailed Design Procedure

The oscillation frequency is determined by the resistor and capacitor values. The following calculation provides details of the steps.

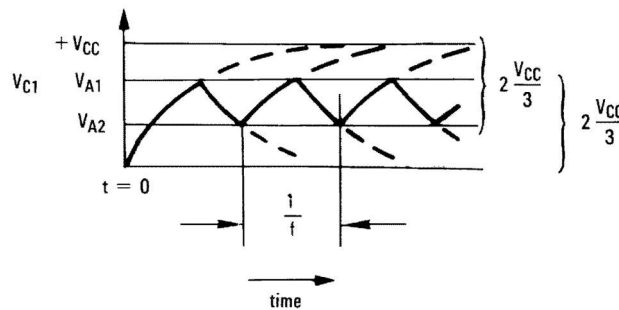

Figure 7-10. Square-Wave Oscillator Timing Thresholds

First consider the output of Figure [Figure 7-9](#) as high, which indicates the inverted input V_C is lower than the noninverting input (V_A). This causes the C_1 to be charged through R_4 , and the voltage V_C increases until it is equal to the noninverting input. The value of V_A at the point is calculated by [Equation 7](#).

$$V_{A1} = \frac{V_{CC} \times R_2}{R_2 + R_1 \parallel R_3} \quad (7)$$

if $R_1 = R_2 = R_3$, then $V_{A1} = 2V_{CC} / 3$

At this time the comparator output trips pulling down the output to the negative rail. The value of V_A at this point is calculated by [Equation 8](#).

$$V_{A2} = \frac{V_{CC}(R_2 \parallel R_3)}{R_1 + R_2 \parallel R_3} \quad (8)$$

if $R_1 = R_2 = R_3$, then $V_{A2} = V_{CC}/3$

The C_1 now discharges through the R_4 , and the voltage V_{CC} decreases until it reaches V_{A2} . At this point, the output switches back to the starting state. The oscillation period equals to the time duration for C_1 from $2V_{CC}/3$ to $V_{CC}/3$ then back to $2V_{CC}/3$, which is given by $R_4 C_1 \times \ln 2$ for each trip. Therefore, the total time duration is calculated as $2 R_4 C_1 \times \ln 2$.

The oscillation frequency can be obtained by [Equation 9](#):

$$f = 1 / (2 R_4 \times C_1 \times \ln 2) \quad (9)$$

7.2.2.3 Application Curve

[Figure 7-11](#) shows the simulated results of an oscillator using the following component values:

- $R_1 = R_2 = R_3 = R_4 = 100\text{k}\Omega$
- $C_1 = 100\text{pF}$, $C_L = 20\text{pF}$
- $V_+ = 5\text{V}$, $V_- = \text{GND}$
- C_{stray} (not shown) from V_A TO GND = 10pF

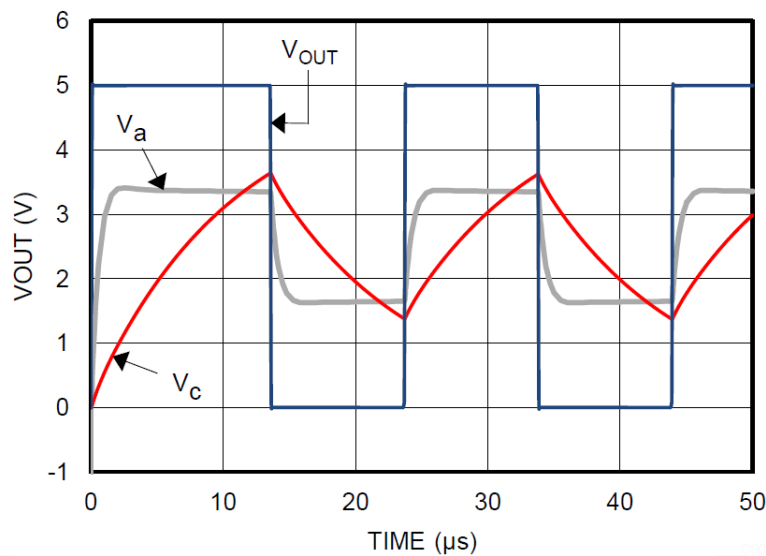

Figure 7-11. Square-Wave Oscillator Output Waveform

7.2.3 Adjustable Pulse Width Generator

[Figure 7-12](#) is a variation on the [square wave oscillator](#) that allows adjusting the pulse widths.

R_4 and R_5 provide separate charge and discharge paths for the capacitor C depending on the output state.

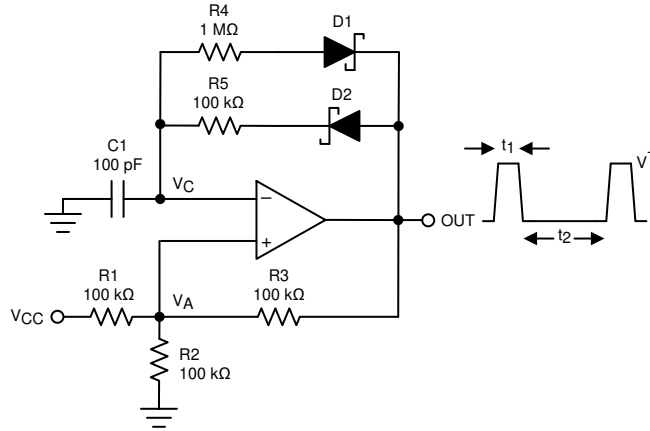

Figure 7-12. Adjustable Pulse Width Generator

The charge path is set through R_5 and D_2 when the output is high. Similarly, the discharge path for the capacitor is set by R_4 and D_1 when the output is low.

The pulse width t_1 is determined by the RC time constant of R_5 and C . Thus, the time t_2 between the pulses can be changed by varying R_4 , and the pulse width can be altered by R_5 . The frequency of the output can be changed by varying both R_4 and R_5 . At low voltages, the effects of the diode forward drop (0.8V, or 0.15V for Schottky) must be taken into account by altering output high and low voltages in the calculations.

7.2.4 Time Delay Generator

The circuit shown in Figure 7-13 provides output signals at a prescribed time interval from a time reference and automatically resets the output low when the input returns to 0V. This is useful for sequencing a "power on" signal to trigger a controlled start-up of power supplies.

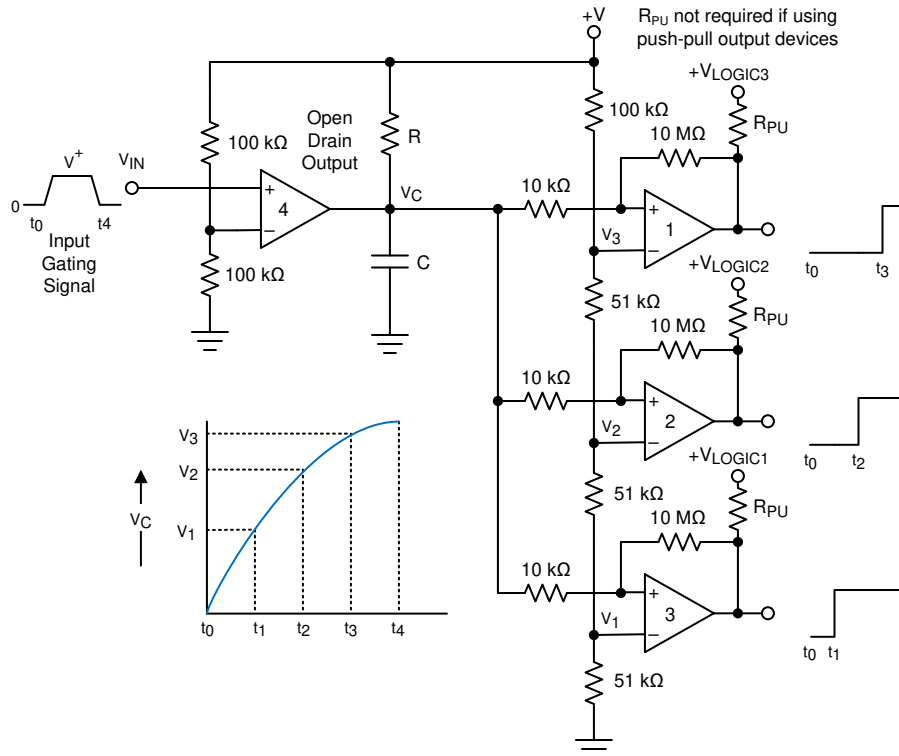

Figure 7-13. Time Delay Generator

Consider the case of $V_{IN} = 0$. The output of comparator 4 is also at ground, "shorting" the capacitor and holding it at 0V. This implies that the outputs of comparators 1, 2, and 3 are also at 0V. When an input signal is applied, the output of open drain comparator 4 goes High-Z and C charges exponentially through R. This is indicated in the graph. The output voltages of comparators 1, 2, and 3 switch to the high state in sequence when V_C rises above the reference voltages V_1 , V_2 and V_3 . A small amount of hysteresis has been provided by the 10k Ω and 10M Ω resistors to insure fast switching when the RC time constant is chosen to give long delay times. A good starting point is $R = 100\text{k}\Omega$ and $C = 0.01\mu\text{F}$ to $1\mu\text{F}$.

All outputs immediately go low when V_{IN} falls to 0V, due to the comparator output going low and immediately discharging the capacitor.

Comparator 4 must be a open-drain type output (TLV902x-Q1), whereas comparators 1 though 3 can be either open drain or push-pull output, depending on system requirements. R_{PU} is not required for push-pull output devices.

7.2.5 Logic Level Shifter

The output of the TLV902x-Q1 is the uncommitted drain of the output transistor. Many open-drain outputs can be tied together to provide an output OR'ing function if desired.

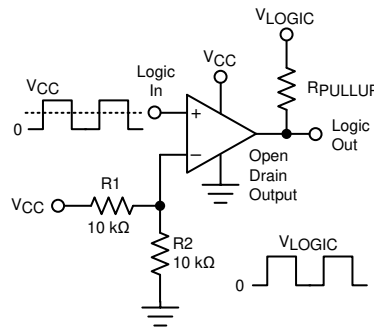

Figure 7-14. Universal Logic Level Shifter

The two 10k Ω resistors bias the input to half of the input logic supply level to set the threshold in the mid-point of the input logic levels. Only one shared output pull-up resistor is needed and can be connected to any pull-up voltage between 0V and 5.5V. The pullup voltage must match the driven logic input "high" level.

7.2.6 One-Shot Multivibrator

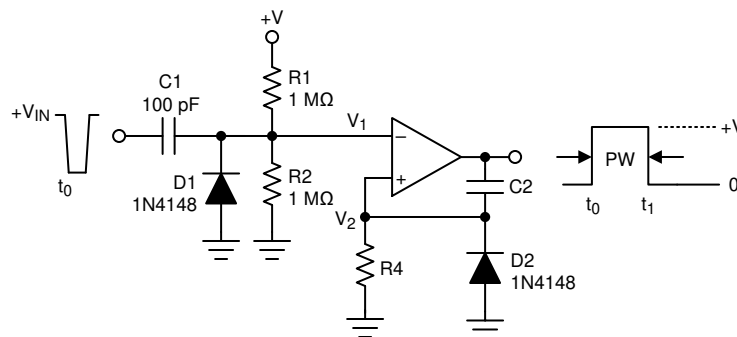

Figure 7-15. One-Shot Multivibrator

A monostable multivibrator has one stable state in which it can remain indefinitely. It can be triggered externally to another quasi-stable state. A monostable multivibrator can thus be used to generate a pulse of desired width.

The desired pulse width is set by adjusting the values of C_2 and R_4 . The resistor divider of R_1 and R_2 can be used to determine the magnitude of the input trigger pulse. The output will change state when $V_1 < V_2$. Diode

D_2 provides a rapid discharge path for capacitor C_2 to reset at the end of the pulse. The diode also prevents the non-inverting input from being driven below ground.

7.2.7 Bi-Stable Multivibrator

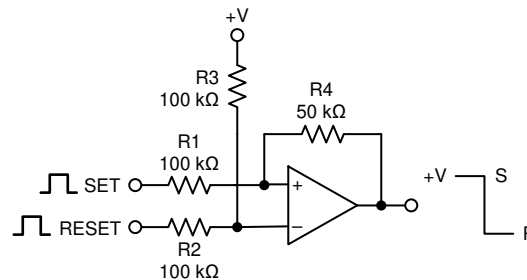

Figure 7-16. Bi-Stable Multivibrator

A bi-stable multivibrator has two stable states. The reference voltage is set up by the voltage divider of R_2 and R_3 . A pulse applied to the SET terminal will switch the output of the comparator high. The resistor divider of R_1 , R_4 , and R_5 now clamps the non-inverting input to a voltage greater than the reference voltage. A pulse applied to RESET will now toggle the output low.

7.2.8 Zero Crossing Detector

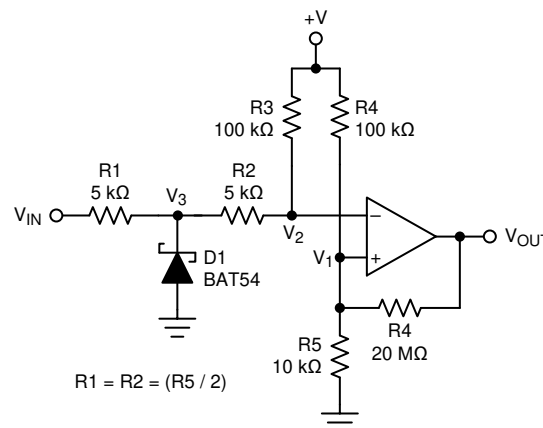

Figure 7-17. Zero Crossing Detector

A voltage divider of R_4 and R_5 establishes a reference voltage V_1 at the non-inverting input. By making the series resistance of R_1 and R_2 equal to R_5 , the comparator will switch when $V_{IN} = 0$. Diode D_1 insures that V_3 clamps near ground. The voltage divider of R_2 and R_3 then prevents V_2 from going below ground. A small amount of hysteresis is setup to ensure rapid output voltage transitions.

7.2.9 Pulse Slicer

A Pulse Slicer is a variation of the Zero Crossing Detector and is used to detect the zero crossings on an input signal with a varying baseline level. This circuit works best with symmetrical waveforms. The RC network of R_1 and C_1 establishes an mean reference voltage V_{REF} , which tracks the mean amplitude of the V_{IN} signal. The noninverting input is directly connected to V_{REF} through R_2 . R_2 and R_3 are used to produce hysteresis to keep transitions free of spurious toggles. The time constant is a tradeoff between long-term symmetry and response time to changes in amplitude.

When the waveform is data, TI recommends that the data be encoded in NRZ (Non-Return to Zero) format to maintain proper average baseline. Asymmetrical inputs may suffer from timing distortions caused by the changing V_{REF} average voltage.

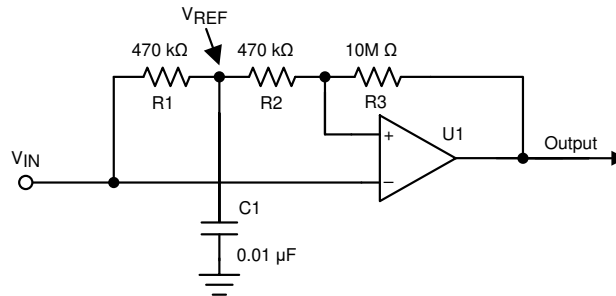

Figure 7-18. Pulse Slicer Using TLV903x-Q1

For this design, follow these design requirements:

- The RC constant value (R_2 and C_1) must support the targeted data rate to maintain a valid tripping threshold.
- The hysteresis introduced with R_2 and R_{43} helps to avoid spurious output toggles.

The TLV902x-Q1 can also be used, but with the addition of a pull-up resistor on the output (not shown for clarity).

Figure 7-19 shows the results of a 9600 baud data signal riding on a varying baseline.

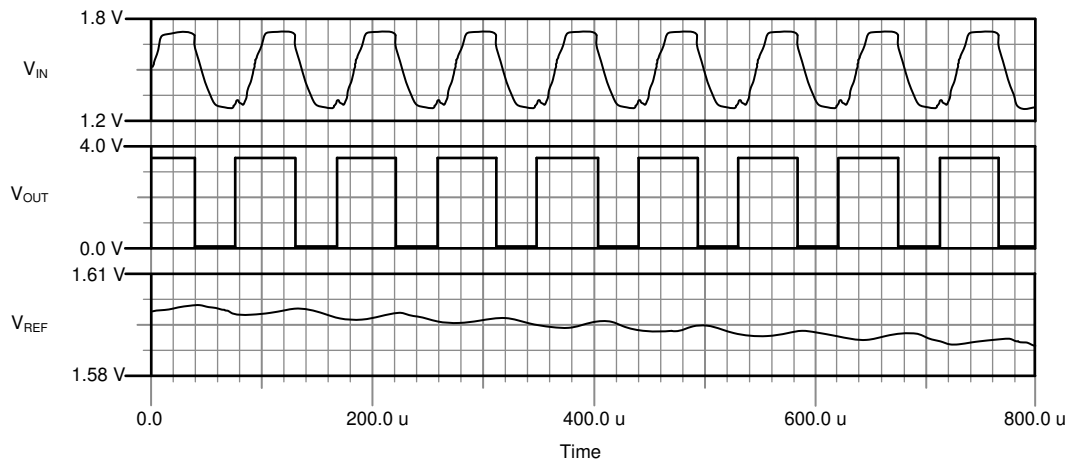

Figure 7-19. Pulse Slicer Waveforms

7.3 Power Supply Recommendations

Due to the fast output edges, it is critical to have bypass capacitors on the supply pin to prevent supply ringing and false triggers and oscillations. Bypass the supply directly at *each* device with a low ESR 0.1μF ceramic bypass capacitor directly between V_{CC} pin and ground pins. Narrow, peak currents will be drawn during the output transition time, particularly for the push-pull output device. These narrow pulses can cause un-bypassed supply lines and poor grounds to ring, possibly causing variation that can eat into the input voltage range and create an inaccurate comparison or even oscillations.

The device can be powered from either "split" supplies ($V+$, $V-$ & GND), or a "single" supply ($V+$ and GND), with GND applied to the $V-$ pin.

Input signals must stay within the specified input range (between $V+$ and $V-$) for either type.

Note that on "split" supplies, the output now swings "low" (V_{OL}) to $V-$ potential and not GND.

8 Layout

8.1 Layout Guidelines

For accurate comparator applications it is important maintain a stable power supply with minimized noise and glitches. Output rise and fall times are in the tens of nanoseconds, and must be treated as high speed logic devices. The bypass capacitor must be as close to the supply pin as possible and connected to a solid ground plane, and preferably directly between the V_{CC} and GND pins.

Minimize coupling between outputs and inputs to prevent output oscillations. Do not run output and input traces in parallel unless there is a V_{CC} or GND trace between output to reduce coupling. When series resistance is added to inputs, place resistor close to the device. A low value (<100 ohms) resistor may also be added in series with the output to dampen any ringing or reflections on long, non-impedance controlled traces. For best edge shapes, controlled impedance traces with back-terminations must be used when routing long distances.

8.2 Layout Example

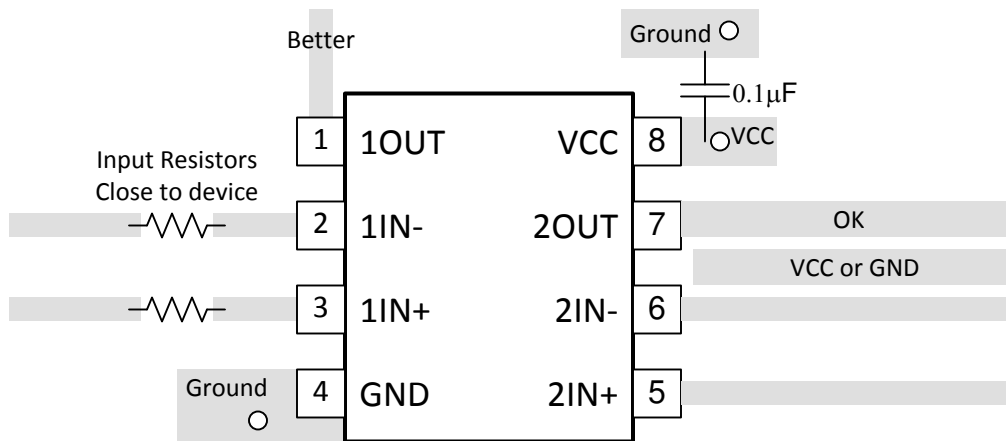

Figure 8-1. Dual Layout Example

9 Device and Documentation Support

9.1 Documentation Support

9.1.1 Related Documentation

[Analog Engineers Circuit Cookbook: Amplifiers \(See Comparators section\) - SLYY137](#)

[Precision Design, Comparator with Hysteresis Reference Design— TIDU020](#)

[Window comparator circuit - SBOA221](#)

[Reference Design, Window Comparator Reference Design— TIPD178](#)

[Comparator with and without hysteresis circuit - SBOA219](#)

[Inverting comparator with hysteresis circuit - SNOA997](#)

[Non-Inverting Comparator With Hysteresis Circuit - SBOA313](#)

[Zero crossing detection using comparator circuit - SNOA999](#)

[PWM generator circuit - SBOA212](#)

[How to Implement Comparators for Improving Performance of Rotary Encoder in Industrial Drive Applications - SNOAA41](#)

[A Quad of Independently Func Comparators - SNOA654](#)

9.2 Receiving Notification of Documentation Updates

To receive notification of documentation updates, navigate to the device product folder on [ti.com](https://www.ti.com). Click on *Notifications* to register and receive a weekly digest of any product information that has changed. For change details, review the revision history included in any revised document.

9.3 Support Resources

[TI E2E™ support forums](#) are an engineer's go-to source for fast, verified answers and design help — straight from the experts. Search existing answers or ask your own question to get the quick design help you need.

Linked content is provided "AS IS" by the respective contributors. They do not constitute TI specifications and do not necessarily reflect TI's views; see TI's [Terms of Use](#).

9.4 Trademarks

TI E2E™ is a trademark of Texas Instruments.

All trademarks are the property of their respective owners.

9.5 Electrostatic Discharge Caution



This integrated circuit can be damaged by ESD. Texas Instruments recommends that all integrated circuits be handled with appropriate precautions. Failure to observe proper handling and installation procedures can cause damage.

ESD damage can range from subtle performance degradation to complete device failure. Precision integrated circuits may be more susceptible to damage because very small parametric changes could cause the device not to meet its published specifications.

9.6 Glossary

[TI Glossary](#) This glossary lists and explains terms, acronyms, and definitions.

10 Revision History

NOTE: Page numbers for previous revisions may differ from page numbers in the current version.

Changes from Revision D (May 2023) to Revision E (May 2024)	Page
• Updated dual WSON and quad WQFN status.....	1

Changes from Revision C (January 2022) to Revision D (May 2023)	Page
• Added Single to front page text, device info, pinout, thermal and EC tables.....	1

Changes from Revision B (August 2021) to Revision C (January 2022)	Page
• Updated VSSOP status in Device Info table.....	1

Changes from Revision A (December 2020) to Revision B (August 2021)	Page
• Added status to Device Info table.....	1

Changes from Revision * (June 2020) to Revision A (December 2020)	Page
• Updated the numbering format for tables, figures, and cross-references throughout the document.....	1
• Added tables for Quad.....	6
• Added Typical Graphs.....	14

11 Mechanical, Packaging, and Orderable Information

The following pages include mechanical, packaging, and orderable information. This information is the most current data available for the designated devices. This data is subject to change without notice and revision of this document. For browser-based versions of this data sheet, refer to the left-hand navigation.

PACKAGING INFORMATION

Orderable Device	Status (1)	Package Type	Package Drawing	Pins	Package Qty	Eco Plan (2)	Lead finish/ Ball material (6)	MSL Peak Temp (3)	Op Temp (°C)	Device Marking (4/5)	Samples
TLV9020QDBVRQ1	ACTIVE	SOT-23	DBV	5	3000	RoHS & Green	NIPDAU	Level-1-260C-UNLIM	-40 to 125	T20Q	Samples
TLV9020QDCKRQ1	ACTIVE	SC70	DCK	5	3000	RoHS & Green	NIPDAU	Level-1-260C-UNLIM	-40 to 125	1OV	Samples
TLV9021QDBVRQ1	ACTIVE	SOT-23	DBV	5	3000	RoHS & Green	NIPDAU	Level-1-260C-UNLIM	-40 to 125	T21Q	Samples
TLV9021QDCKRQ1	ACTIVE	SC70	DCK	5	3000	RoHS & Green	NIPDAU	Level-1-260C-UNLIM	-40 to 125	1OW	Samples
TLV9022QDDFRQ1	ACTIVE	SOT-23-THIN	DDF	8	3000	RoHS & Green	NIPDAU	Level-1-260C-UNLIM	-40 to 125	2H3FQ	Samples
TLV9022QDGKRQ1	ACTIVE	VSSOP	DGK	8	2500	RoHS & Green	NIPDAU	Level-1-260C-UNLIM	-40 to 125	IFTQ	Samples
TLV9022QDRQ1	ACTIVE	SOIC	D	8	2500	RoHS & Green	NIPDAU	Level-1-260C-UNLIM	-40 to 125	TQ022Q	Samples
TLV9022QPWRQ1	ACTIVE	TSSOP	PW	8	2000	RoHS & Green	NIPDAU	Level-1-260C-UNLIM	-40 to 125	T9022Q	Samples
TLV9022WDSGRQ1	ACTIVE	WSON	DSG	8	3000	RoHS & Green	SN	Level-2-260C-1 YEAR	-40 to 125	2SZH	Samples
TLV9024QDRQ1	ACTIVE	SOIC	D	14	2500	RoHS & Green	NIPDAU	Level-1-260C-UNLIM	-40 to 125	TLV9024QD	Samples
TLV9024QDYRQ1	ACTIVE	SOT-23-THIN	DYY	14	3000	RoHS & Green	NIPDAU	Level-1-260C-UNLIM	-40 to 125	TLV9024Q	Samples
TLV9024QPWRQ1	ACTIVE	TSSOP	PW	14	2000	RoHS & Green	NIPDAU	Level-1-260C-UNLIM	-40 to 125	TL9024Q	Samples
TLV9030QDBVRQ1	ACTIVE	SOT-23	DBV	5	3000	RoHS & Green	NIPDAU	Level-1-260C-UNLIM	-40 to 125	T30Q	Samples
TLV9030QDCKRQ1	ACTIVE	SC70	DCK	5	3000	RoHS & Green	NIPDAU	Level-1-260C-UNLIM	-40 to 125	1OX	Samples
TLV9031QDBVRQ1	ACTIVE	SOT-23	DBV	5	3000	RoHS & Green	NIPDAU	Level-1-260C-UNLIM	-40 to 125	T31Q	Samples
TLV9031QDCKRQ1	ACTIVE	SC70	DCK	5	3000	RoHS & Green	NIPDAU	Level-1-260C-UNLIM	-40 to 125	1OZ	Samples
TLV9032QDDFRQ1	ACTIVE	SOT-23-THIN	DDF	8	3000	RoHS & Green	NIPDAU	Level-1-260C-UNLIM	-40 to 125	2H2FQ	Samples
TLV9032QDGKRQ1	ACTIVE	VSSOP	DGK	8	2500	RoHS & Green	NIPDAU	Level-1-260C-UNLIM	-40 to 125	IGTQ	Samples
TLV9032QDRQ1	ACTIVE	SOIC	D	8	2500	RoHS & Green	NIPDAU	Level-1-260C-UNLIM	-40 to 125	T9032Q	Samples
TLV9032QPWRQ1	ACTIVE	TSSOP	PW	8	2000	RoHS & Green	NIPDAU	Level-1-260C-UNLIM	-40 to 125	T9032Q	Samples

Orderable Device	Status (1)	Package Type	Package Drawing	Pins	Package Qty	Eco Plan (2)	Lead finish/ Ball material (6)	MSL Peak Temp (3)	Op Temp (°C)	Device Marking (4/5)	Samples
TLV9034QDRQ1	ACTIVE	SOIC	D	14	2500	RoHS & Green	NIPDAU	Level-1-260C-UNLIM	-40 to 125	TLV9034QD	Samples
TLV9034QDYRQ1	ACTIVE	SOT-23-THIN	DYY	14	3000	RoHS & Green	NIPDAU	Level-1-260C-UNLIM	-40 to 125	TLV9034Q	Samples
TLV9034QPWRQ1	ACTIVE	TSSOP	PW	14	2000	RoHS & Green	NIPDAU	Level-1-260C-UNLIM	-40 to 125	TL9034Q	Samples

(1) The marketing status values are defined as follows:

ACTIVE: Product device recommended for new designs.

LIFEBUY: TI has announced that the device will be discontinued, and a lifetime-buy period is in effect.

NRND: Not recommended for new designs. Device is in production to support existing customers, but TI does not recommend using this part in a new design.

PREVIEW: Device has been announced but is not in production. Samples may or may not be available.

OBSOLETE: TI has discontinued the production of the device.

(2) **RoHS:** TI defines "RoHS" to mean semiconductor products that are compliant with the current EU RoHS requirements for all 10 RoHS substances, including the requirement that RoHS substance do not exceed 0.1% by weight in homogeneous materials. Where designed to be soldered at high temperatures, "RoHS" products are suitable for use in specified lead-free processes. TI may reference these types of products as "Pb-Free".

RoHS Exempt: TI defines "RoHS Exempt" to mean products that contain lead but are compliant with EU RoHS pursuant to a specific EU RoHS exemption.

Green: TI defines "Green" to mean the content of Chlorine (Cl) and Bromine (Br) based flame retardants meet JS709B low halogen requirements of <=1000ppm threshold. Antimony trioxide based flame retardants must also meet the <=1000ppm threshold requirement.

(3) MSL, Peak Temp. - The Moisture Sensitivity Level rating according to the JEDEC industry standard classifications, and peak solder temperature.

(4) There may be additional marking, which relates to the logo, the lot trace code information, or the environmental category on the device.

(5) Multiple Device Markings will be inside parentheses. Only one Device Marking contained in parentheses and separated by a "-" will appear on a device. If a line is indented then it is a continuation of the previous line and the two combined represent the entire Device Marking for that device.

(6) Lead finish/Ball material - Orderable Devices may have multiple material finish options. Finish options are separated by a vertical ruled line. Lead finish/Ball material values may wrap to two lines if the finish value exceeds the maximum column width.

Important Information and Disclaimer:The information provided on this page represents TI's knowledge and belief as of the date that it is provided. TI bases its knowledge and belief on information provided by third parties, and makes no representation or warranty as to the accuracy of such information. Efforts are underway to better integrate information from third parties. TI has taken and continues to take reasonable steps to provide representative and accurate information but may not have conducted destructive testing or chemical analysis on incoming materials and chemicals. TI and TI suppliers consider certain information to be proprietary, and thus CAS numbers and other limited information may not be available for release.

In no event shall TI's liability arising out of such information exceed the total purchase price of the TI part(s) at issue in this document sold by TI to Customer on an annual basis.

OTHER QUALIFIED VERSIONS OF TLV9020-Q1, TLV9021-Q1, TLV9022-Q1, TLV9024-Q1, TLV9030-Q1, TLV9031-Q1, TLV9032-Q1, TLV9034-Q1 :

- Catalog : [TLV9020](#), [TLV9021](#), [TLV9022](#), [TLV9024](#), [TLV9030](#), [TLV9031](#), [TLV9032](#), [TLV9034](#)

NOTE: Qualified Version Definitions:

- Catalog - TI's standard catalog product

TAPE AND REEL INFORMATION

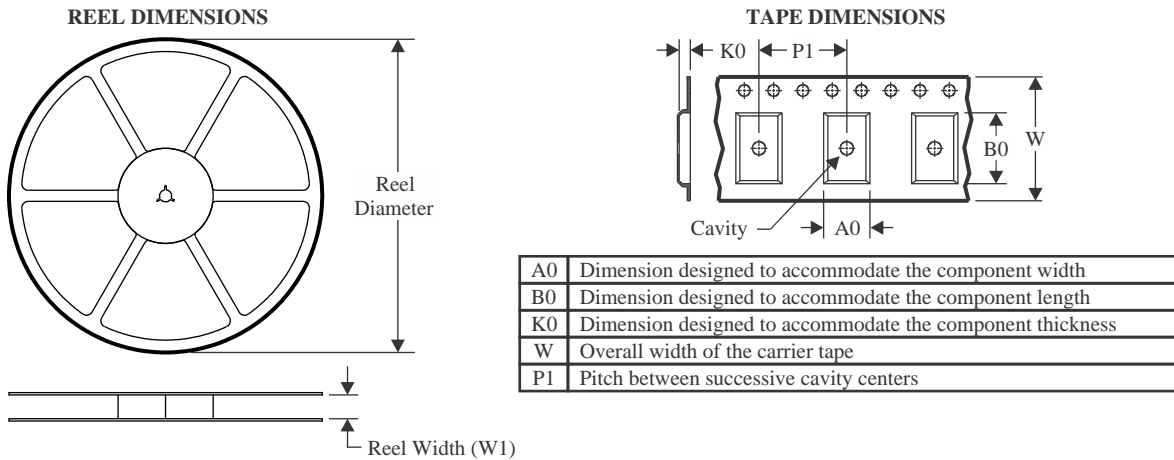

QUADRANT ASSIGNMENTS FOR PIN 1 ORIENTATION IN TAPE

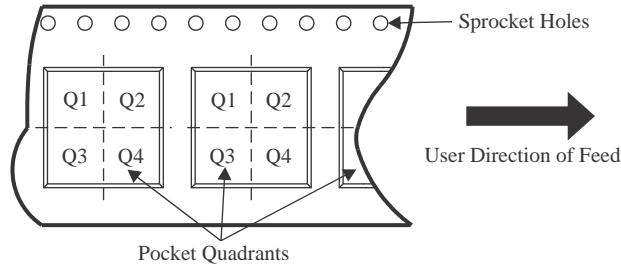

*All dimensions are nominal

Device	Package Type	Package Drawing	Pins	SPQ	Reel Diameter (mm)	Reel Width W1 (mm)	A0 (mm)	B0 (mm)	K0 (mm)	P1 (mm)	W (mm)	Pin1 Quadrant
TLV9020QDBVRQ1	SOT-23	DBV	5	3000	180.0	8.4	3.2	3.2	1.4	4.0	8.0	Q3
TLV9020QDCKRQ1	SC70	DCK	5	3000	178.0	9.0	2.4	2.5	1.2	4.0	8.0	Q3
TLV9021QDBVRQ1	SOT-23	DBV	5	3000	180.0	8.4	3.2	3.2	1.4	4.0	8.0	Q3
TLV9021QDCKRQ1	SC70	DCK	5	3000	178.0	9.0	2.4	2.5	1.2	4.0	8.0	Q3
TLV9022QDDFRQ1	SOT-23-THIN	DDF	8	3000	180.0	8.4	3.2	3.2	1.4	4.0	8.0	Q3
TLV9022QDGRQ1	VSSOP	DGK	8	2500	330.0	12.4	5.3	3.4	1.4	8.0	12.0	Q1
TLV9022QDRQ1	SOIC	D	8	2500	330.0	12.4	6.4	5.2	2.1	8.0	12.0	Q1
TLV9022QPWRQ1	TSSOP	PW	8	2000	330.0	12.4	7.0	3.6	1.6	8.0	12.0	Q1
TLV9022WDSGRQ1	WSO	DSG	8	3000	180.0	8.4	2.2	2.2	1.2	4.0	8.0	Q2
TLV9024QDRQ1	SOIC	D	14	2500	330.0	16.4	6.5	9.0	2.1	8.0	16.0	Q1
TLV9024QDYRQ1	SOT-23-THIN	DYY	14	3000	330.0	12.4	4.8	3.6	1.6	8.0	12.0	Q3
TLV9024QPWRQ1	TSSOP	PW	14	2000	330.0	12.4	6.9	5.6	1.6	8.0	12.0	Q1
TLV9030QDBVRQ1	SOT-23	DBV	5	3000	180.0	8.4	3.2	3.2	1.4	4.0	8.0	Q3
TLV9030QDCKRQ1	SC70	DCK	5	3000	178.0	9.0	2.4	2.5	1.2	4.0	8.0	Q3
TLV9031QDBVRQ1	SOT-23	DBV	5	3000	180.0	8.4	3.2	3.2	1.4	4.0	8.0	Q3

Device	Package Type	Package Drawing	Pins	SPQ	Reel Diameter (mm)	Reel Width W1 (mm)	A0 (mm)	B0 (mm)	K0 (mm)	P1 (mm)	W (mm)	Pin1 Quadrant
TLV9031QDCKRQ1	SC70	DCK	5	3000	178.0	9.0	2.4	2.5	1.2	4.0	8.0	Q3
TLV9032QDDFRQ1	SOT-23-THIN	DDF	8	3000	180.0	8.4	3.2	3.2	1.4	4.0	8.0	Q3
TLV9032QDGKRQ1	VSSOP	DGK	8	2500	330.0	12.4	5.3	3.4	1.4	8.0	12.0	Q1
TLV9032QDRQ1	SOIC	D	8	2500	330.0	12.4	6.4	5.2	2.1	8.0	12.0	Q1
TLV9034QDRQ1	SOIC	D	14	2500	330.0	16.4	6.5	9.0	2.1	8.0	16.0	Q1
TLV9034QDYRQ1	SOT-23-THIN	DYY	14	3000	330.0	12.4	4.8	3.6	1.6	8.0	12.0	Q3
TLV9034QPWRQ1	TSSOP	PW	14	2000	330.0	12.4	6.9	5.6	1.6	8.0	12.0	Q1

TAPE AND REEL BOX DIMENSIONS



*All dimensions are nominal

Device	Package Type	Package Drawing	Pins	SPQ	Length (mm)	Width (mm)	Height (mm)
TLV9020QDBVRQ1	SOT-23	DBV	5	3000	210.0	185.0	35.0
TLV9020QDCKRQ1	SC70	DCK	5	3000	190.0	190.0	30.0
TLV9021QDBVRQ1	SOT-23	DBV	5	3000	210.0	185.0	35.0
TLV9021QDCKRQ1	SC70	DCK	5	3000	190.0	190.0	30.0
TLV9022QDDFRQ1	SOT-23-THIN	DDF	8	3000	210.0	185.0	35.0
TLV9022QDGKRQ1	VSSOP	DGK	8	2500	366.0	364.0	50.0
TLV9022QDRQ1	SOIC	D	8	2500	356.0	356.0	35.0
TLV9022QPWRQ1	TSSOP	PW	8	2000	356.0	356.0	35.0
TLV9022WDSGRQ1	WSON	DSG	8	3000	213.0	191.0	35.0
TLV9024QDRQ1	SOIC	D	14	2500	356.0	356.0	35.0
TLV9024QDYRQ1	SOT-23-THIN	DYY	14	3000	336.6	336.6	31.8
TLV9024QPWRQ1	TSSOP	PW	14	2000	356.0	356.0	35.0
TLV9030QDBVRQ1	SOT-23	DBV	5	3000	210.0	185.0	35.0
TLV9030QDCKRQ1	SC70	DCK	5	3000	190.0	190.0	30.0
TLV9031QDBVRQ1	SOT-23	DBV	5	3000	210.0	185.0	35.0
TLV9031QDCKRQ1	SC70	DCK	5	3000	190.0	190.0	30.0
TLV9032QDDFRQ1	SOT-23-THIN	DDF	8	3000	210.0	185.0	35.0
TLV9032QDGKRQ1	VSSOP	DGK	8	2500	366.0	364.0	50.0

Device	Package Type	Package Drawing	Pins	SPQ	Length (mm)	Width (mm)	Height (mm)
TLV9032QDRQ1	SOIC	D	8	2500	356.0	356.0	35.0
TLV9034QDRQ1	SOIC	D	14	2500	356.0	356.0	35.0
TLV9034QDYRQ1	SOT-23-THIN	DYY	14	3000	336.6	336.6	31.8
TLV9034QPWRQ1	TSSOP	PW	14	2000	356.0	356.0	35.0

DDF0008A



PACKAGE OUTLINE

SOT-23 - 1.1 mm max height

PLASTIC SMALL OUTLINE

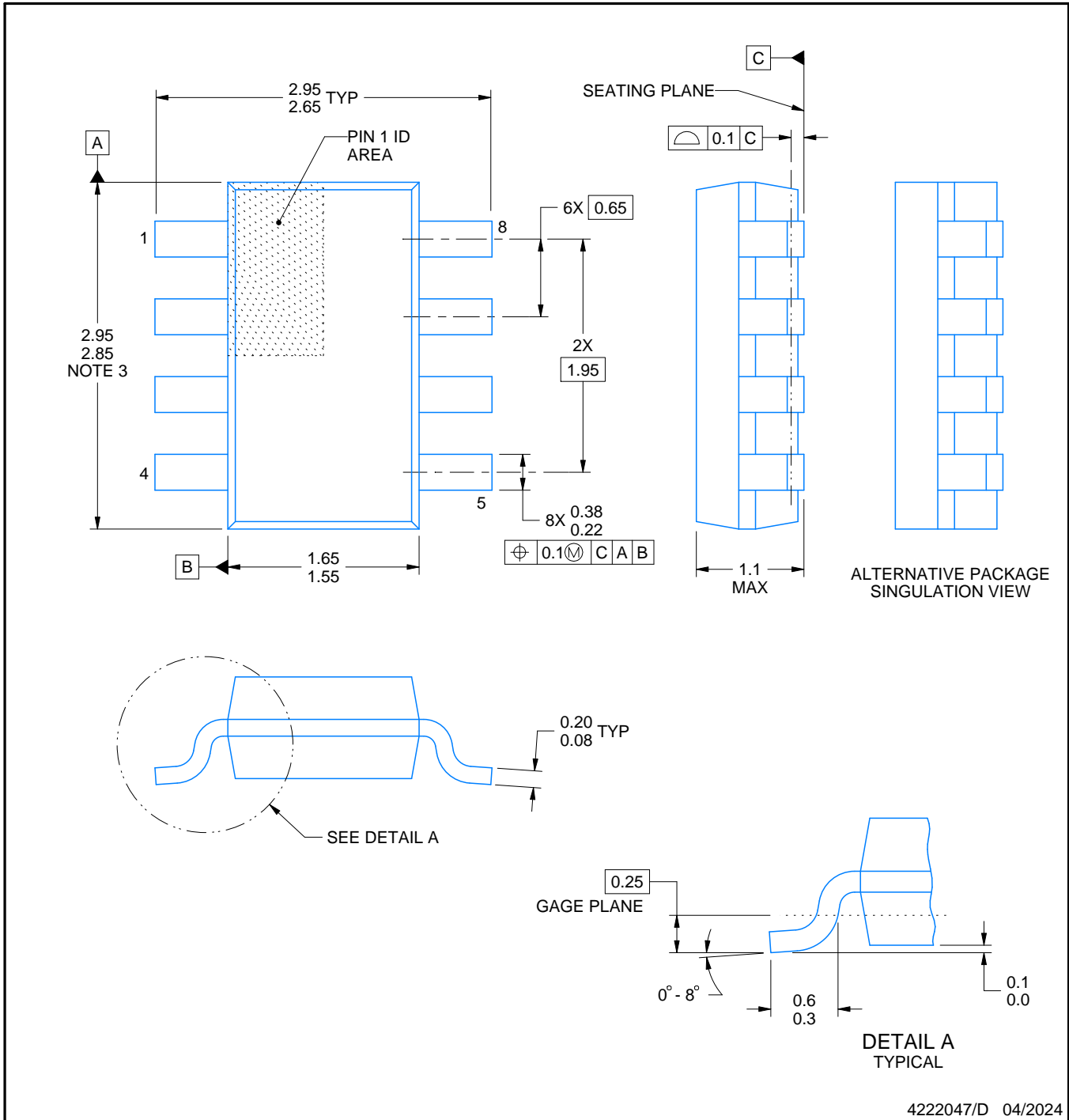

NOTES:

1. All linear dimensions are in millimeters. Any dimensions in parenthesis are for reference only. Dimensioning and tolerancing per ASME Y14.5M.
2. This drawing is subject to change without notice.
3. This dimension does not include mold flash, protrusions, or gate burrs. Mold flash, protrusions, or gate burrs shall not exceed 0.15 mm per side.

EXAMPLE STENCIL DESIGN

DDF0008A

SOT-23 - 1.1 mm max height

PLASTIC SMALL OUTLINE



SOLDER PASTE EXAMPLE
BASED ON 0.125 mm THICK STENCIL
SCALE:15X

4222047/D 04/2024

NOTES: (continued)

6. Laser cutting apertures with trapezoidal walls and rounded corners may offer better paste release. IPC-7525 may have alternate design recommendations.
7. Board assembly site may have different recommendations for stencil design.

EXAMPLE BOARD LAYOUT

DBV0005A

SOT-23 - 1.45 mm max height

SMALL OUTLINE TRANSISTOR



LAND PATTERN EXAMPLE
EXPOSED METAL SHOWN
SCALE:15X

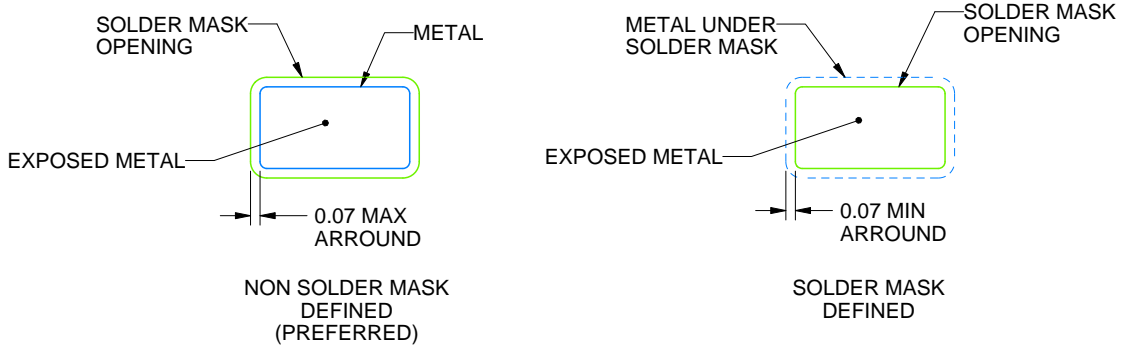

SOLDER MASK DETAILS

4214839/J 02/2024

NOTES: (continued)

- 6. Publication IPC-7351 may have alternate designs.
- 7. Solder mask tolerances between and around signal pads can vary based on board fabrication site.

EXAMPLE STENCIL DESIGN

DBV0005A

SOT-23 - 1.45 mm max height

SMALL OUTLINE TRANSISTOR



SOLDER PASTE EXAMPLE
BASED ON 0.125 mm THICK STENCIL
SCALE:15X

4214839/J 02/2024



NOTES: (continued)

8. Laser cutting apertures with trapezoidal walls and rounded corners may offer better paste release. IPC-7525 may have alternate design recommendations.
9. Board assembly site may have different recommendations for stencil design.

D (R-PDSO-G14)

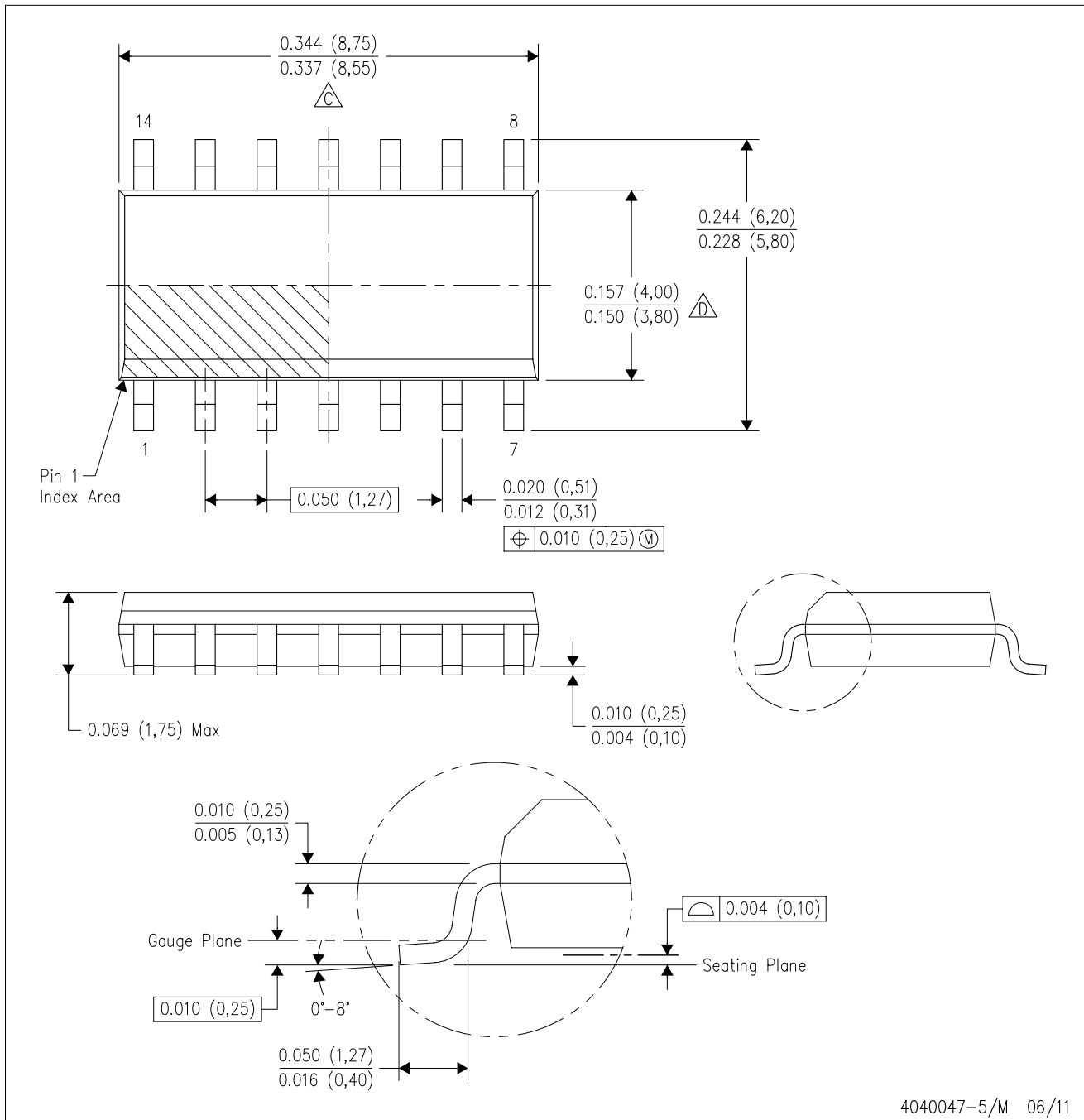
PLASTIC SMALL OUTLINE



- NOTES:
- A. All linear dimensions are in inches (millimeters).
 - B. This drawing is subject to change without notice.
 -  Body length does not include mold flash, protrusions, or gate burrs. Mold flash, protrusions, or gate burrs shall not exceed 0.006 (0,15) each side.
 -  Body width does not include interlead flash. Interlead flash shall not exceed 0.017 (0,43) each side.
 - E. Reference JEDEC MS-012 variation AB.

PW (R-PDSO-G14)

PLASTIC SMALL OUTLINE

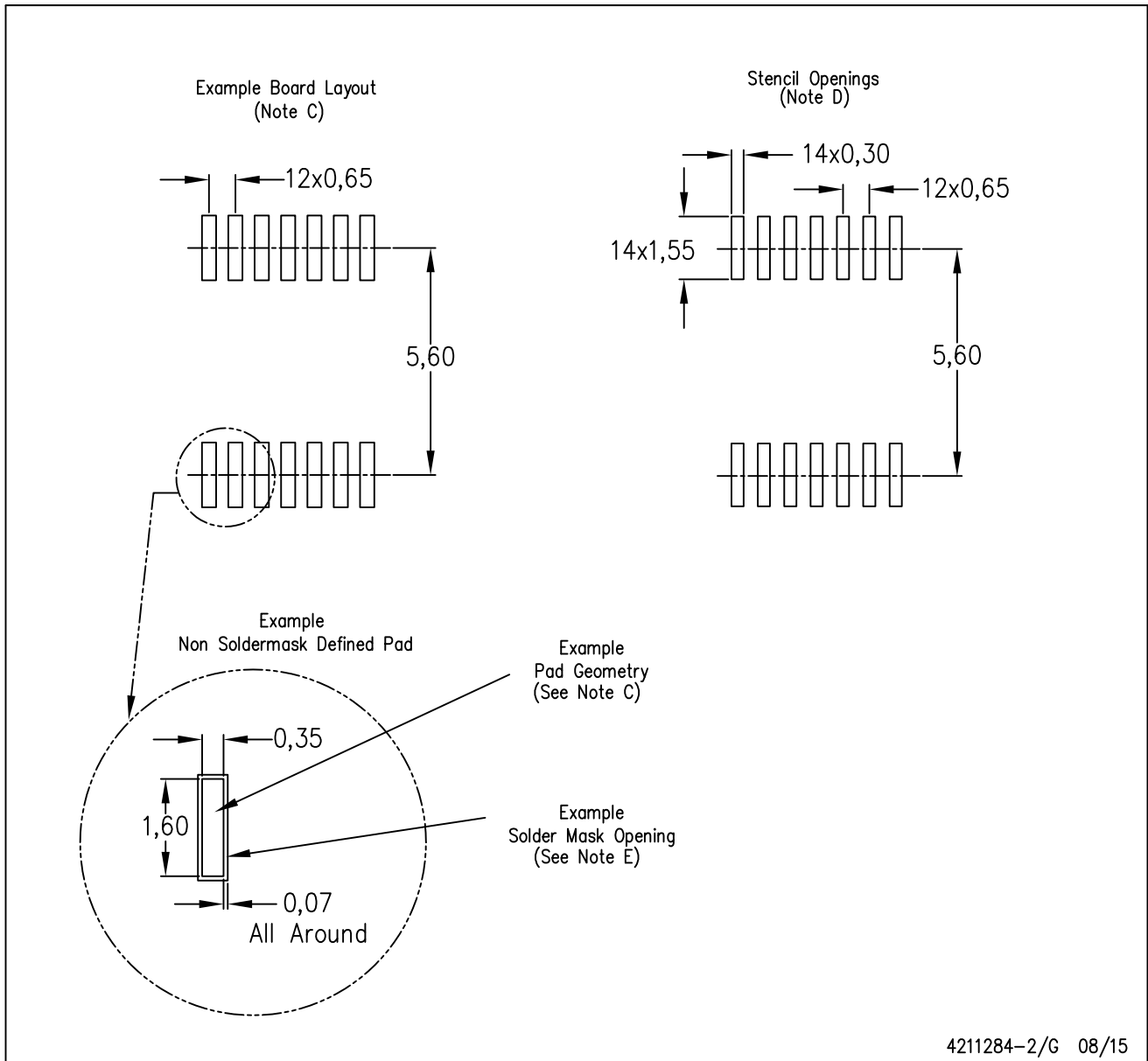

4211284-2/G 08/15

- NOTES:
- All linear dimensions are in millimeters.
 - This drawing is subject to change without notice.
 - Publication IPC-7351 is recommended for alternate designs.
 - Laser cutting apertures with trapezoidal walls and also rounding corners will offer better paste release. Customers should contact their board assembly site for stencil design recommendations. Refer to IPC-7525 for other stencil recommendations.
 - Customers should contact their board fabrication site for solder mask tolerances between and around signal pads.



D0008A

PACKAGE OUTLINE

SOIC - 1.75 mm max height

SMALL OUTLINE INTEGRATED CIRCUIT



NOTES:

1. Linear dimensions are in inches [millimeters]. Dimensions in parenthesis are for reference only. Controlling dimensions are in inches. Dimensioning and tolerancing per ASME Y14.5M.
2. This drawing is subject to change without notice.
3. This dimension does not include mold flash, protrusions, or gate burrs. Mold flash, protrusions, or gate burrs shall not exceed $.006$ [0.15] per side.
4. This dimension does not include interlead flash.
5. Reference JEDEC registration MS-012, variation AA.

EXAMPLE BOARD LAYOUT

D0008A

SOIC - 1.75 mm max height

SMALL OUTLINE INTEGRATED CIRCUIT



LAND PATTERN EXAMPLE
 EXPOSED METAL SHOWN
 SCALE:8X



SOLDER MASK DETAILS

4214825/C 02/2019

NOTES: (continued)

- 6. Publication IPC-7351 may have alternate designs.
- 7. Solder mask tolerances between and around signal pads can vary based on board fabrication site.

EXAMPLE STENCIL DESIGN

D0008A

SOIC - 1.75 mm max height

SMALL OUTLINE INTEGRATED CIRCUIT

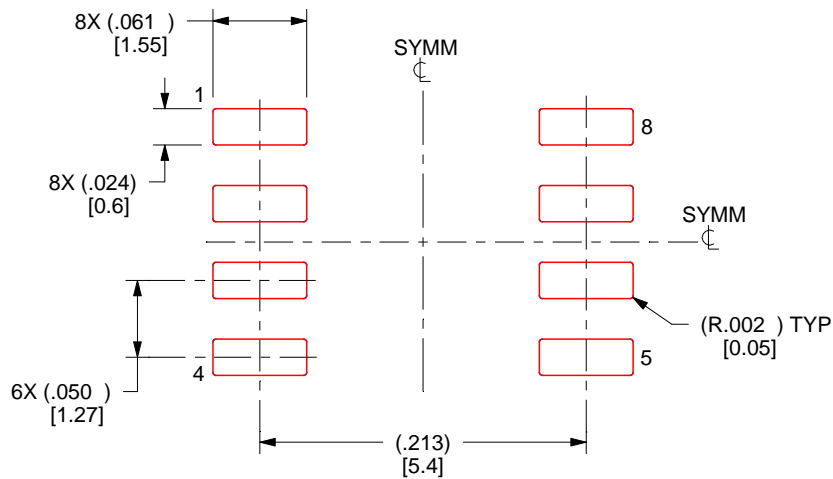

SOLDER PASTE EXAMPLE
BASED ON .005 INCH [0.125 MM] THICK STENCIL
SCALE:8X

4214825/C 02/2019

NOTES: (continued)

8. Laser cutting apertures with trapezoidal walls and rounded corners may offer better paste release. IPC-7525 may have alternate design recommendations.
9. Board assembly site may have different recommendations for stencil design.

GENERIC PACKAGE VIEW

DSG 8

WSON - 0.8 mm max height

2 x 2, 0.5 mm pitch

PLASTIC SMALL OUTLINE - NO LEAD

This image is a representation of the package family, actual package may vary.
Refer to the product data sheet for package details.

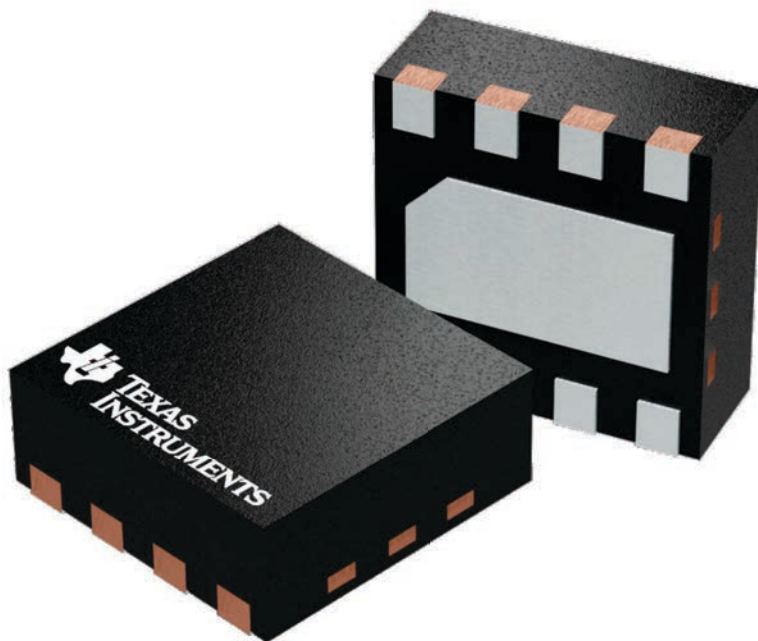

4224783/A

DSG0008B

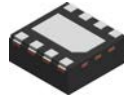

PACKAGE OUTLINE

WSON - 0.8 mm max height

PLASTIC SMALL OUTLINE - NO LEAD

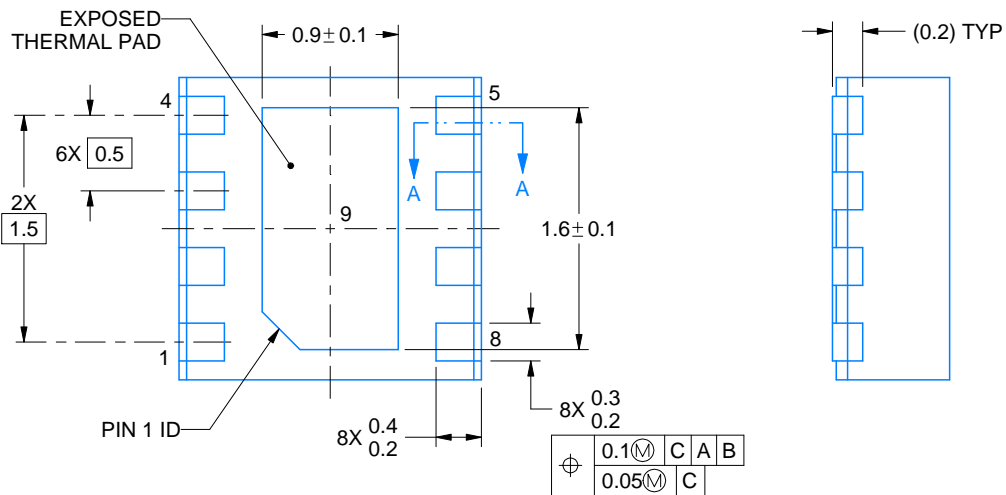
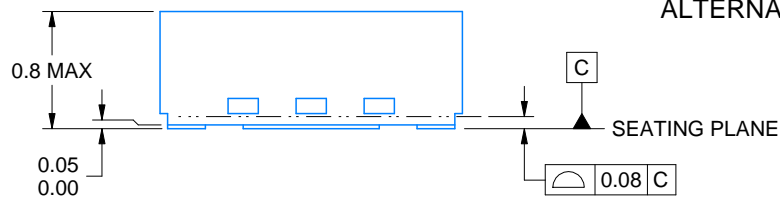
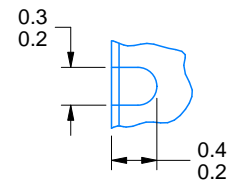
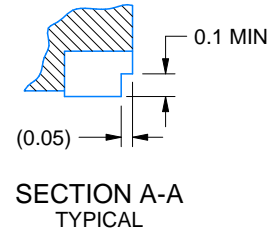
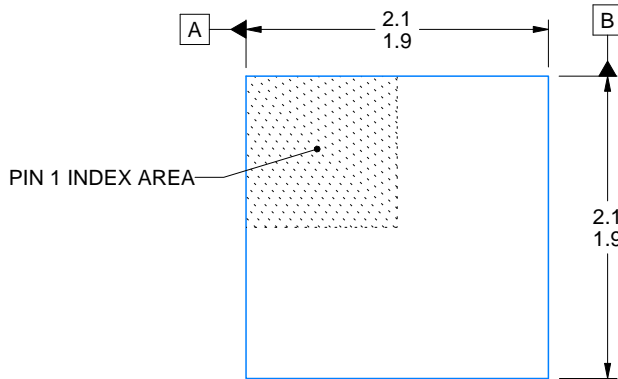

4222124/E 05/2020

NOTES:

1. All linear dimensions are in millimeters. Any dimensions in parenthesis are for reference only. Dimensioning and tolerancing per ASME Y14.5M.
2. This drawing is subject to change without notice.
3. The package thermal pad must be soldered to the printed circuit board for thermal and mechanical performance.

EXAMPLE STENCIL DESIGN

DSG0008B

WSON - 0.8 mm max height

PLASTIC SMALL OUTLINE - NO LEAD

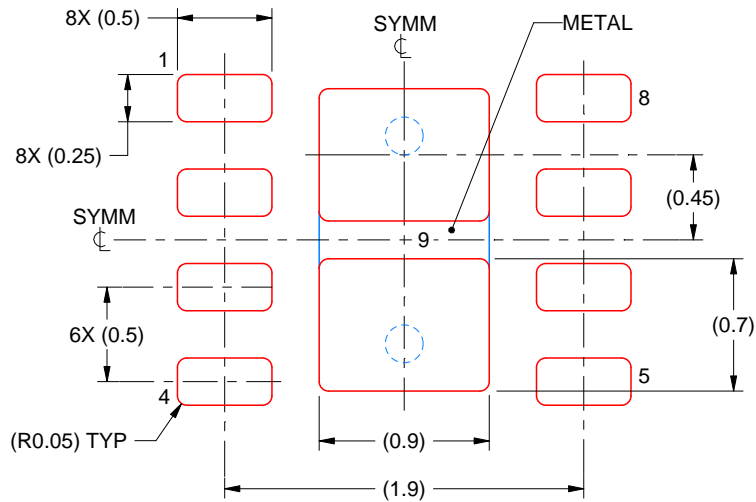

SOLDER PASTE EXAMPLE
BASED ON 0.125 mm THICK STENCIL

EXPOSED PAD 9:
87% PRINTED SOLDER COVERAGE BY AREA UNDER PACKAGE
SCALE:25X

4222124/E 05/2020

NOTES: (continued)

6. Laser cutting apertures with trapezoidal walls and rounded corners may offer better paste release. IPC-7525 may have alternate design recommendations.

PW0008A



PACKAGE OUTLINE
TSSOP - 1.2 mm max height

SMALL OUTLINE PACKAGE

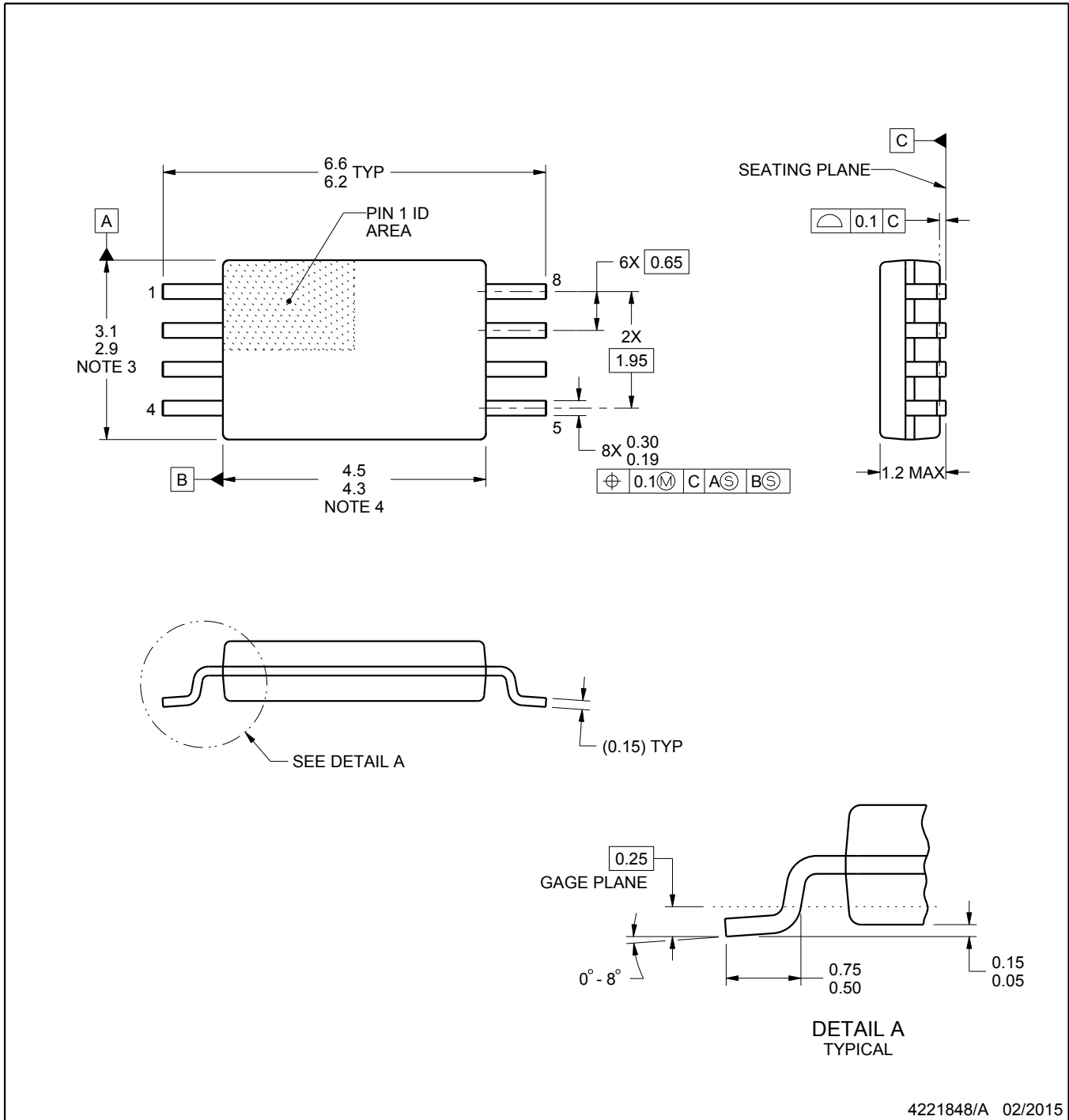

NOTES:

1. All linear dimensions are in millimeters. Any dimensions in parenthesis are for reference only. Dimensioning and tolerancing per ASME Y14.5M.
2. This drawing is subject to change without notice.
3. This dimension does not include mold flash, protrusions, or gate burrs. Mold flash, protrusions, or gate burrs shall not exceed 0.15 mm per side.
4. This dimension does not include interlead flash. Interlead flash shall not exceed 0.25 mm per side.
5. Reference JEDEC registration MO-153, variation AA.

EXAMPLE BOARD LAYOUT

PW0008A

TSSOP - 1.2 mm max height

SMALL OUTLINE PACKAGE

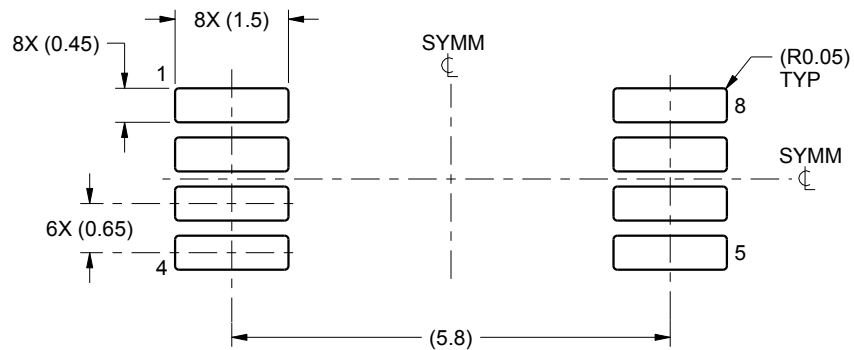

LAND PATTERN EXAMPLE
SCALE:10X

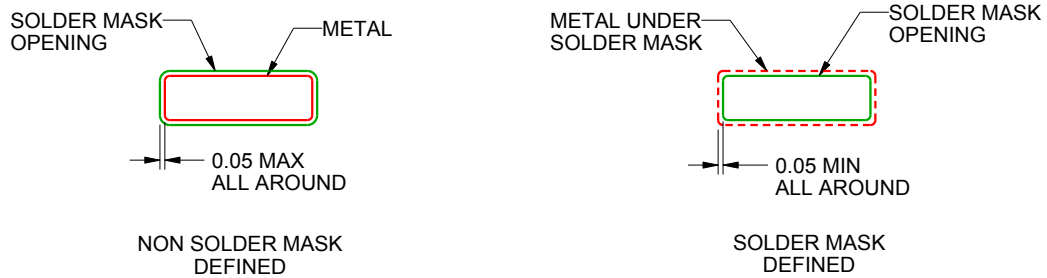

SOLDER MASK DETAILS
NOT TO SCALE

4221848/A 02/2015

NOTES: (continued)

- 6. Publication IPC-7351 may have alternate designs.
- 7. Solder mask tolerances between and around signal pads can vary based on board fabrication site.

EXAMPLE STENCIL DESIGN

PW0008A

TSSOP - 1.2 mm max height

SMALL OUTLINE PACKAGE

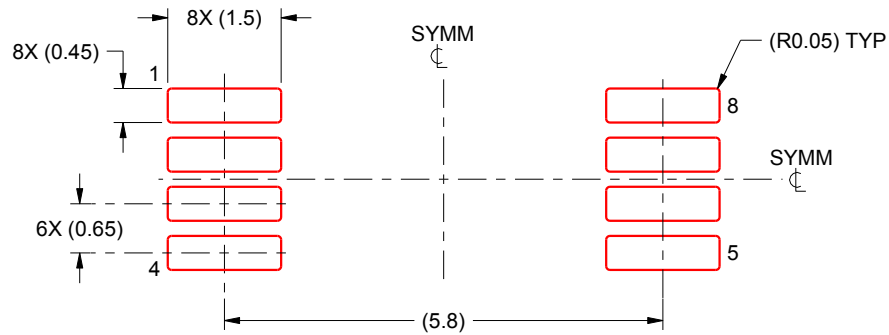

SOLDER PASTE EXAMPLE
BASED ON 0.125 mm THICK STENCIL
SCALE:10X

4221848/A 02/2015

NOTES: (continued)

8. Laser cutting apertures with trapezoidal walls and rounded corners may offer better paste release. IPC-7525 may have alternate design recommendations.
9. Board assembly site may have different recommendations for stencil design.

DCK0005A



PACKAGE OUTLINE

SOT - 1.1 max height

SMALL OUTLINE TRANSISTOR

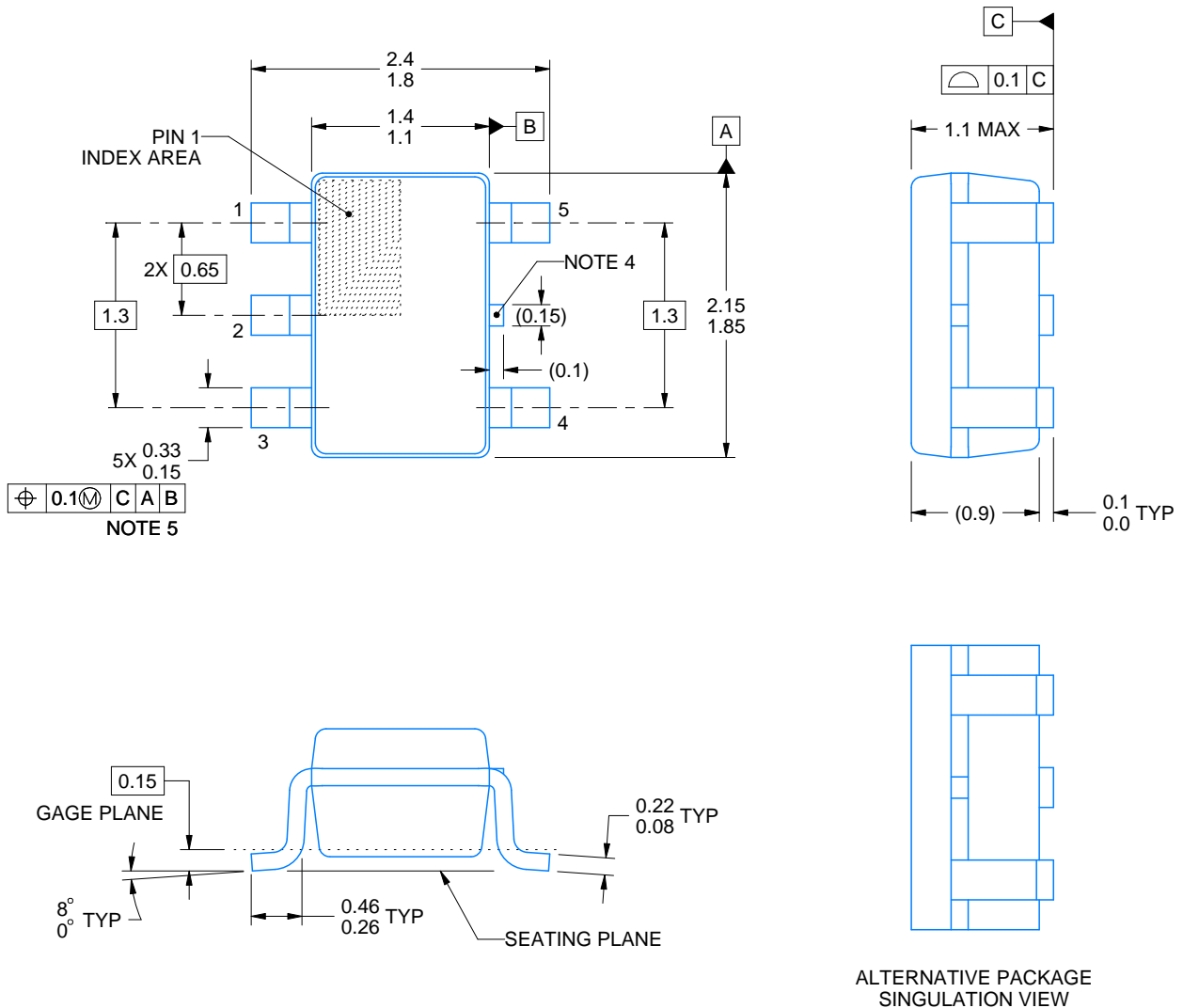

4214834/E 06/2024

NOTES:

1. All linear dimensions are in millimeters. Any dimensions in parenthesis are for reference only. Dimensioning and tolerancing per ASME Y14.5M.
2. This drawing is subject to change without notice.
3. Reference JEDEC MO-203.
4. Support pin may differ or may not be present.
5. Lead width does not comply with JEDEC.
6. Body dimensions do not include mold flash, protrusions, or gate burrs. Mold flash, protrusions, or gate burrs shall not exceed 0.25mm per side

EXAMPLE BOARD LAYOUT

DCK0005A

SOT - 1.1 max height

SMALL OUTLINE TRANSISTOR

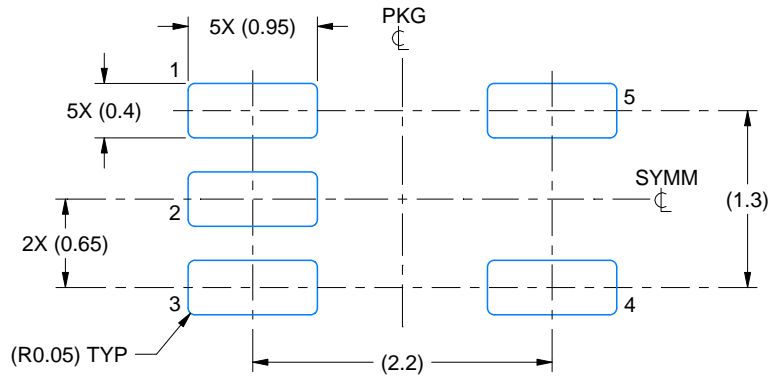

LAND PATTERN EXAMPLE
EXPOSED METAL SHOWN
SCALE:18X

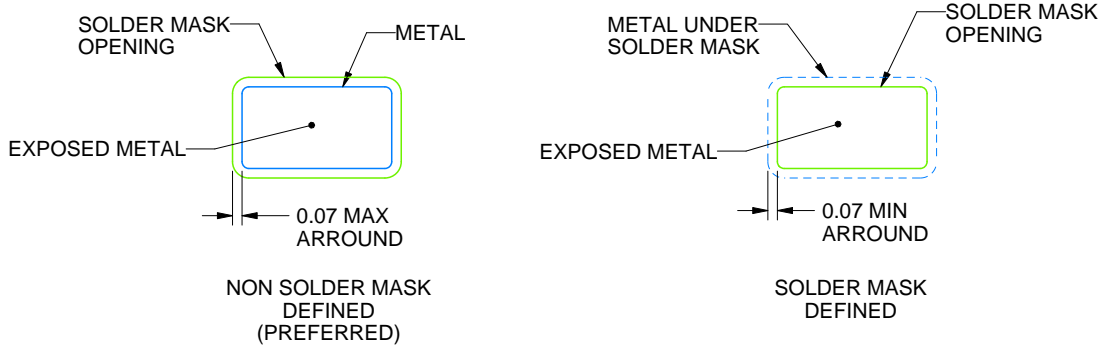

SOLDER MASK DETAILS

4214834/E 06/2024

NOTES: (continued)

- 7. Publication IPC-7351 may have alternate designs.
- 8. Solder mask tolerances between and around signal pads can vary based on board fabrication site.

EXAMPLE STENCIL DESIGN

DCK0005A

SOT - 1.1 max height

SMALL OUTLINE TRANSISTOR

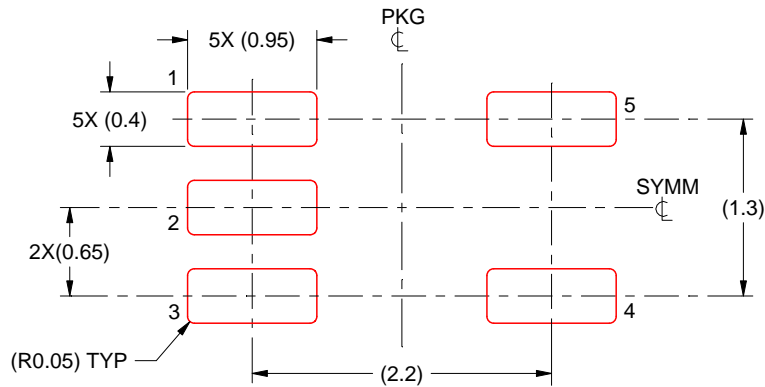

SOLDER PASTE EXAMPLE
BASED ON 0.125 THICK STENCIL
SCALE: 18X

4214834/E 06/2024

NOTES: (continued)

9. Laser cutting apertures with trapezoidal walls and rounded corners may offer better paste release. IPC-7525 may have alternate design recommendations.
10. Board assembly site may have different recommendations for stencil design.

DGK0008A

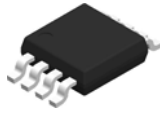

PACKAGE OUTLINE

VSSOP - 1.1 mm max height

SMALL OUTLINE PACKAGE

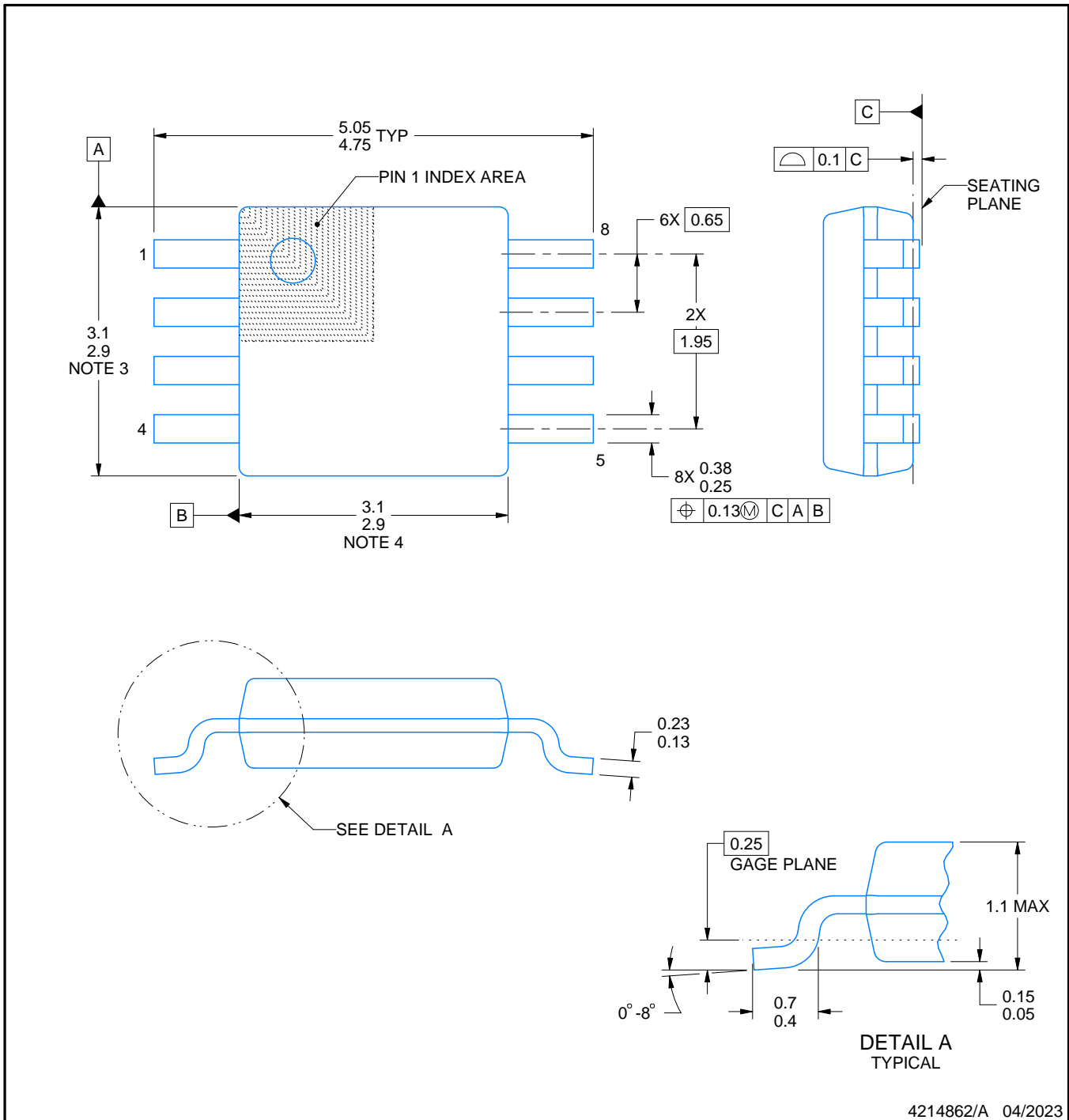

NOTES:

PowerPAD is a trademark of Texas Instruments.

1. All linear dimensions are in millimeters. Any dimensions in parenthesis are for reference only. Dimensioning and tolerancing per ASME Y14.5M.
2. This drawing is subject to change without notice.
3. This dimension does not include mold flash, protrusions, or gate burrs. Mold flash, protrusions, or gate burrs shall not exceed 0.15 mm per side.
4. This dimension does not include interlead flash. Interlead flash shall not exceed 0.25 mm per side.
5. Reference JEDEC registration MO-187.

EXAMPLE BOARD LAYOUT

DGK0008A

™ VSSOP - 1.1 mm max height

SMALL OUTLINE PACKAGE

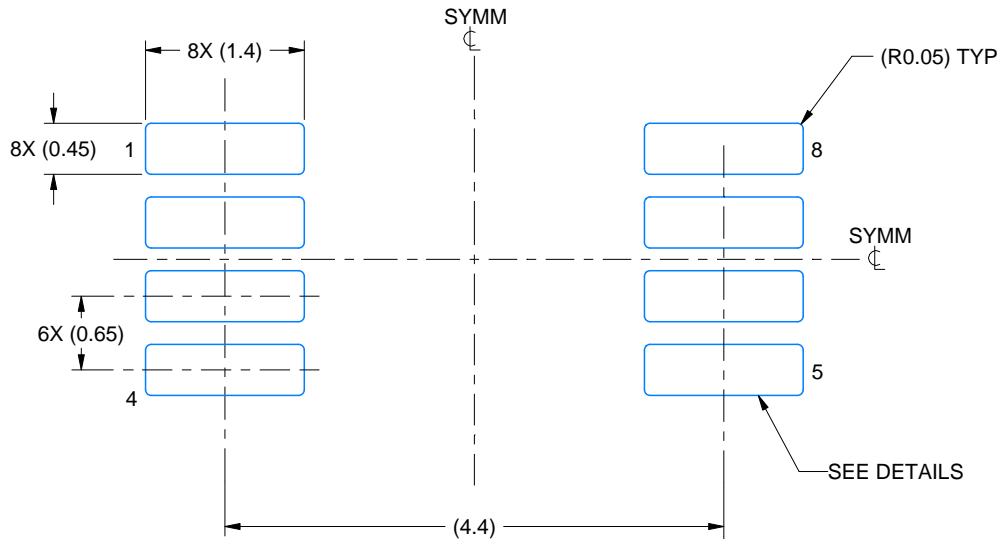

LAND PATTERN EXAMPLE
EXPOSED METAL SHOWN
SCALE: 15X

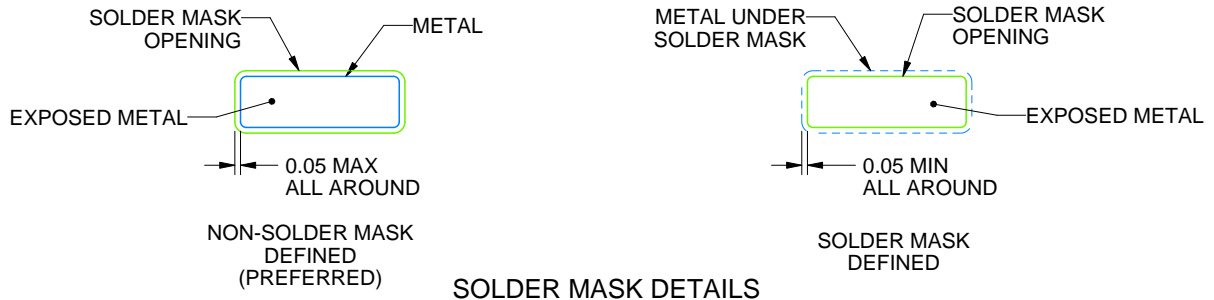

SOLDER MASK DETAILS

4214862/A 04/2023

NOTES: (continued)

6. Publication IPC-7351 may have alternate designs.
7. Solder mask tolerances between and around signal pads can vary based on board fabrication site.
8. Vias are optional depending on application, refer to device data sheet. If any vias are implemented, refer to their locations shown on this view. It is recommended that vias under paste be filled, plugged or tented.
9. Size of metal pad may vary due to creepage requirement.

EXAMPLE STENCIL DESIGN

DGK0008A

TM VSSOP - 1.1 mm max height

SMALL OUTLINE PACKAGE

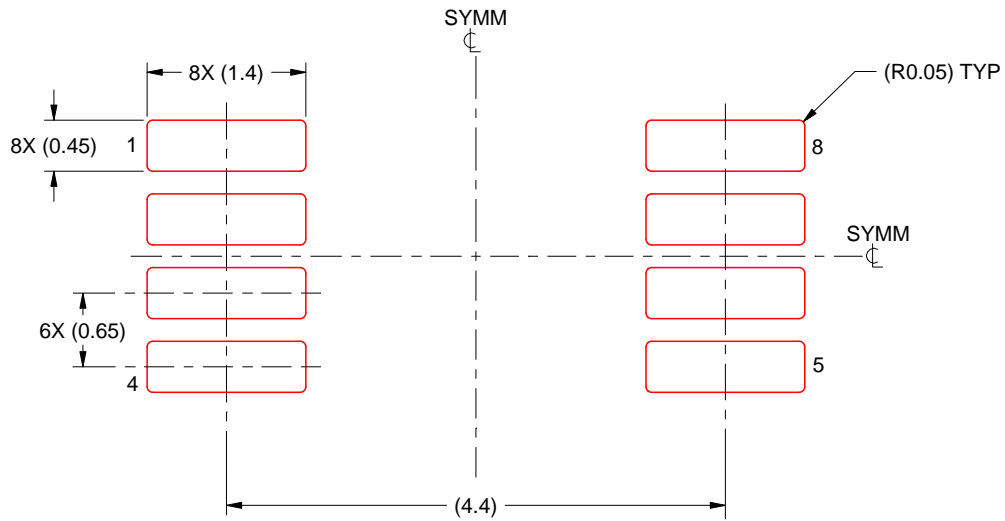

SOLDER PASTE EXAMPLE
SCALE: 15X

4214862/A 04/2023

NOTES: (continued)

11. Laser cutting apertures with trapezoidal walls and rounded corners may offer better paste release. IPC-7525 may have alternate design recommendations.
12. Board assembly site may have different recommendations for stencil design.

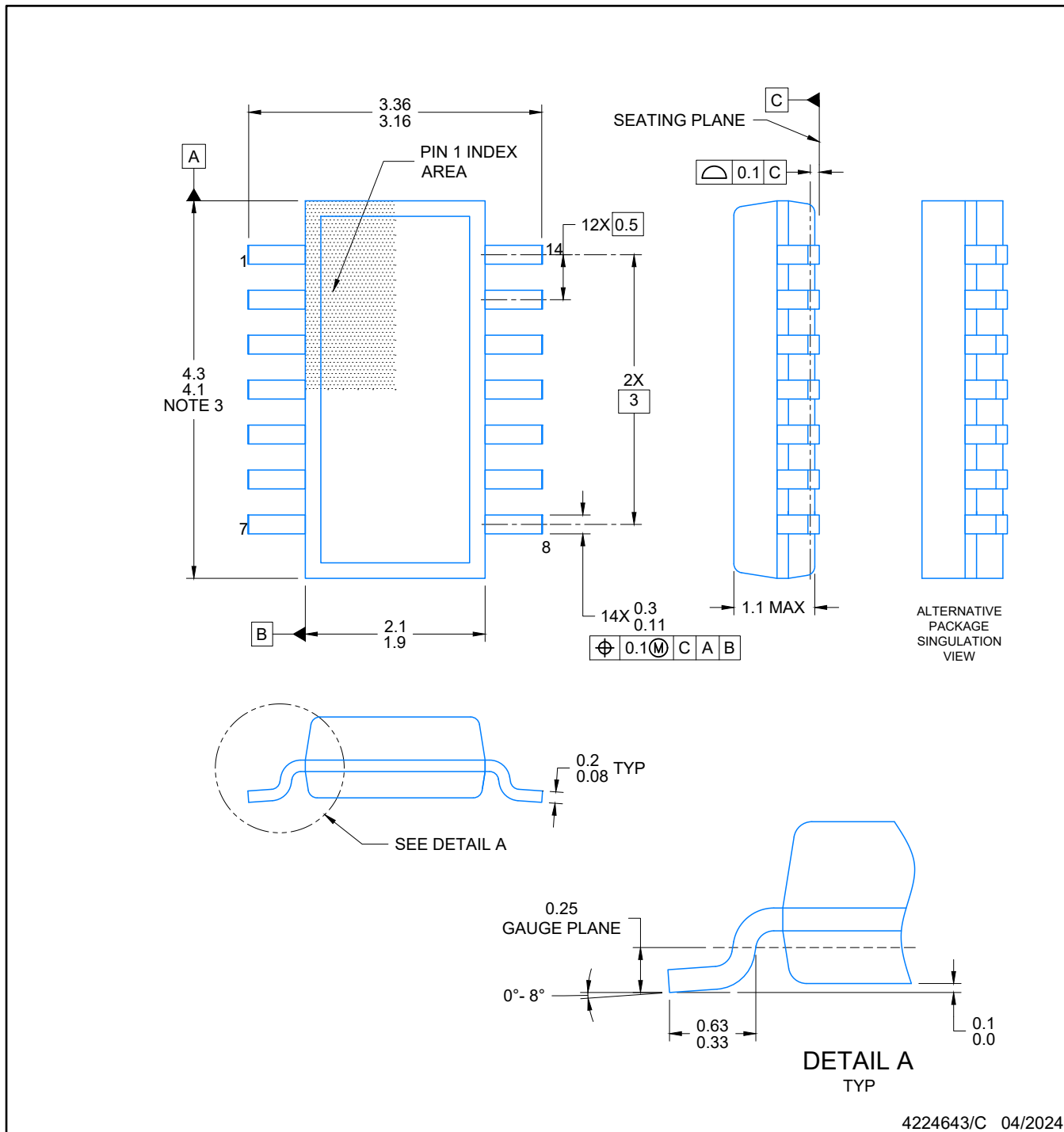

4224643/C 04/2024

NOTES:

1. All linear dimensions are in millimeters. Any dimensions in parenthesis are for reference only. Dimensioning and tolerancing per ASME Y14.5M.
2. This drawing is subject to change without notice.
3. This dimension does not include mold flash, protrusions, or gate burrs. Mold flash, protrusions, or gate burrs shall not exceed 0.15 per side.
4. This dimension does not include interlead flash. Interlead flash shall not exceed 0.50 per side.
5. Reference JEDEC Registration MO-345, Variation AB

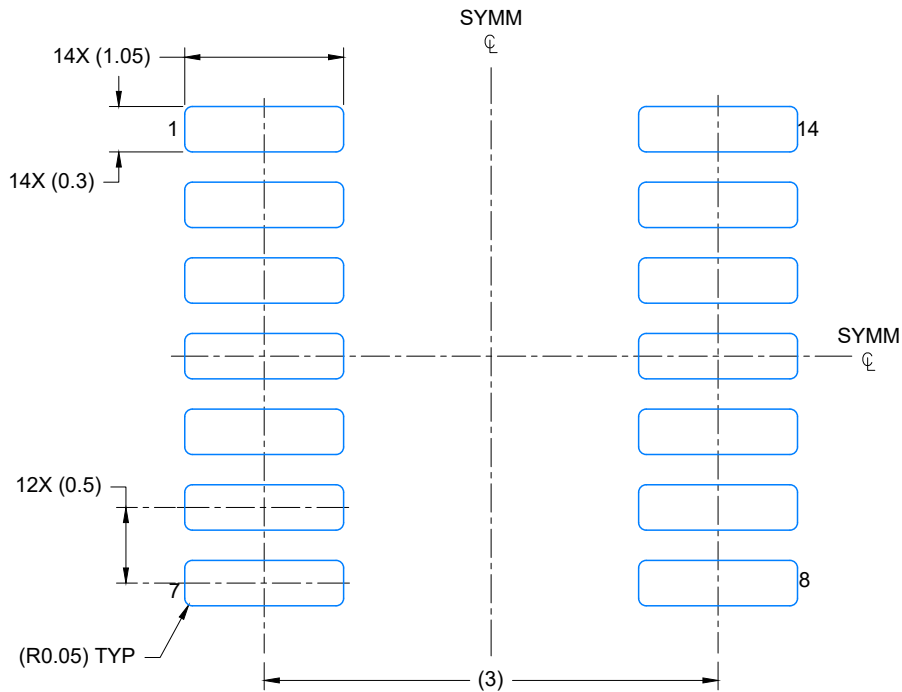

LAND PATTERN EXAMPLE
EXPOSED METAL SHOWN
SCALE: 20X

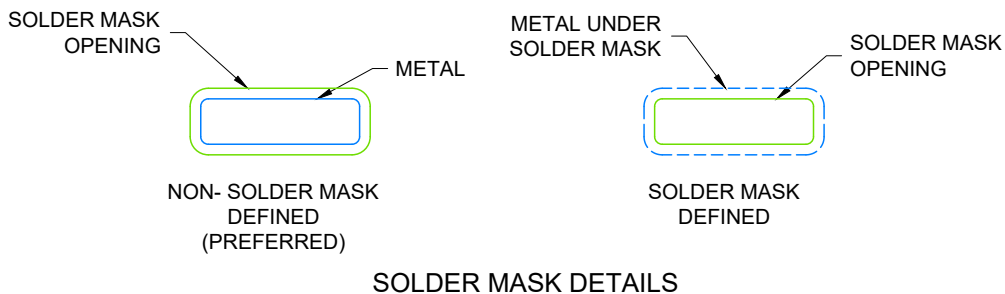

4224643/C 04/2024

NOTES: (continued)

- 6. Publication IPC-7351 may have alternate designs.
- 7. Solder mask tolerances between and around signal pads can vary based on board fabrication site.

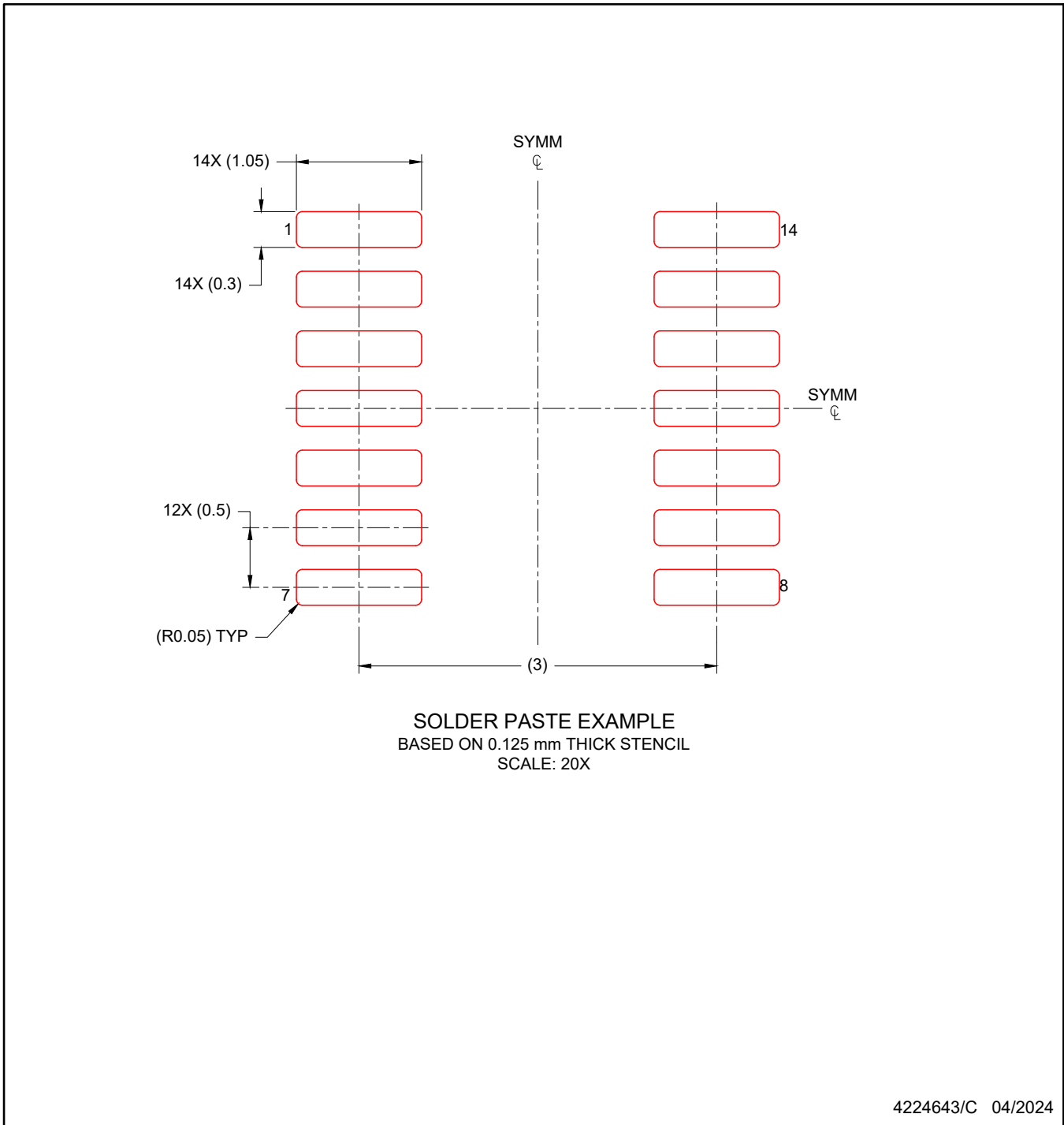

NOTES: (continued)

8. Laser cutting apertures with trapezoidal walls and rounded corners may offer better paste release. IPC-7525 may have alternate design recommendations.
9. Board assembly site may have different recommendations for stencil design.

IMPORTANT NOTICE AND DISCLAIMER

TI PROVIDES TECHNICAL AND RELIABILITY DATA (INCLUDING DATA SHEETS), DESIGN RESOURCES (INCLUDING REFERENCE DESIGNS), APPLICATION OR OTHER DESIGN ADVICE, WEB TOOLS, SAFETY INFORMATION, AND OTHER RESOURCES "AS IS" AND WITH ALL FAULTS, AND DISCLAIMS ALL WARRANTIES, EXPRESS AND IMPLIED, INCLUDING WITHOUT LIMITATION ANY IMPLIED WARRANTIES OF MERCHANTABILITY, FITNESS FOR A PARTICULAR PURPOSE OR NON-INFRINGEMENT OF THIRD PARTY INTELLECTUAL PROPERTY RIGHTS.

These resources are intended for skilled developers designing with TI products. You are solely responsible for (1) selecting the appropriate TI products for your application, (2) designing, validating and testing your application, and (3) ensuring your application meets applicable standards, and any other safety, security, regulatory or other requirements.

These resources are subject to change without notice. TI grants you permission to use these resources only for development of an application that uses the TI products described in the resource. Other reproduction and display of these resources is prohibited. No license is granted to any other TI intellectual property right or to any third party intellectual property right. TI disclaims responsibility for, and you will fully indemnify TI and its representatives against, any claims, damages, costs, losses, and liabilities arising out of your use of these resources.

TI's products are provided subject to [TI's Terms of Sale](#) or other applicable terms available either on [ti.com](https://www.ti.com) or provided in conjunction with such TI products. TI's provision of these resources does not expand or otherwise alter TI's applicable warranties or warranty disclaimers for TI products.

TI objects to and rejects any additional or different terms you may have proposed.

Mailing Address: Texas Instruments, Post Office Box 655303, Dallas, Texas 75265
Copyright © 2024, Texas Instruments Incorporated

Looking for pricing, stock, or lifecycle information?

Click below to explore more details on WIN SOURCE:

 [View TLV9032QPWRQ1 on WIN SOURCE](#)

 [Texas Instruments](#) Information

Optimize Your Supply Chain with WIN SOURCE Solutions

-  Global Sourcing Solution
-  Obsolete Management
-  Cost Control Management
-  Shortage Management
-  Alternative Solution
-  Excess Inventory Management