



**THE DATASHEET OF  
PL135-37SC-R**



**Low Power, 1.62V to 3.63V, 10MHz to 40MHz, 1:3 Oscillator Fanout Buffer****FEATURES**

- Advanced Oscillator Design for Wide Frequency Coverage
- 3 LVCMOS Outputs
- 12 mA Output Drive Strength
- Input/Output Frequency:
  - Fundamental Crystal: 10MHz to 40MHz
- Very Low Jitter and Phase Noise
- Low Current Consumption
- Single 1.62V to 3.63V Power Supply
- Available in SOP-8L GREEN/RoHS Compliant Package

**DESCRIPTION**

The PL135-37 is an advanced oscillator fanout buffer design for high performance, low-power applications. The PL135-37 accepts a fundamental crystal input of 10MHz to 40MHz and produces three LVCMOS outputs of the same frequency. The Output Enable (OE) function can be used to tri-state the outputs.

The PL135-27 offers the best phase noise and jitter performance and lowest power consumption of any comparable IC.

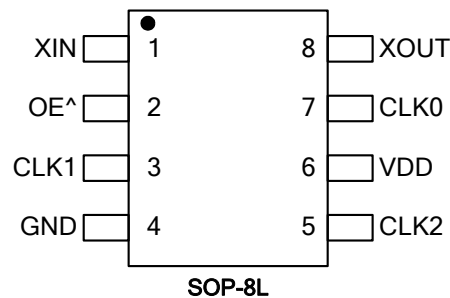
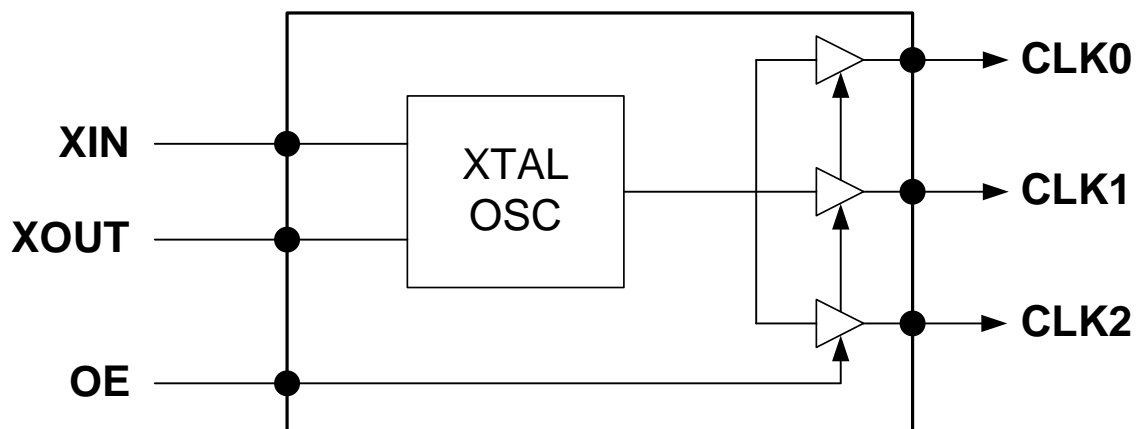
**PACKAGE PIN CONFIGURATION****BLOCK DIAGRAM**

## Low Power, 1.62V to 3.63V, 10MHz to 40MHz, 1:3 Oscillator Fanout Buffer

### PIN DESCRIPTION

Name	SOP-8L	Type	Description
XIN	1	I	Crystal input
OE	2	I	Output enable input. This pin has internal pull-up resistor. All outputs will be tri-stated when pulled low.
CLK1	3	O	Output clock
GND	4	P	Ground connection
CLK2	5	O	Output clock
VDD	6	P	Power supply
CLK0	7	O	Output clock
XOUT	8	I	Crystal output

\* **Note:** This pin includes an internal 60KΩ pull up.

### LAYOUT RECOMMENDATIONS

The following guidelines are to assist you with a performance optimized PCB design:

#### Signal Integrity and Termination Considerations

- Keep traces short!
- Trace = Inductor. With a capacitive load this equals ringing!
- Long trace = Transmission Line. Without proper termination this will cause reflections (looks like ringing).
- Design long traces as “striplines” or “microstrips” with defined impedance.
- Match trace at one side to avoid reflections bouncing back and forth.

#### Decoupling and Power Supply Considerations

- Place decoupling capacitors as close as possible to the V<sub>DD</sub> pin(s) to limit noise from the power supply
- Multiple V<sub>DD</sub> pins should be decoupled separately for best performance.
- Addition of a ferrite bead in series with V<sub>DD</sub> can help prevent noise from other board sources
- Value of decoupling capacitor is frequency dependant. Typical value to use is 0.1μF.

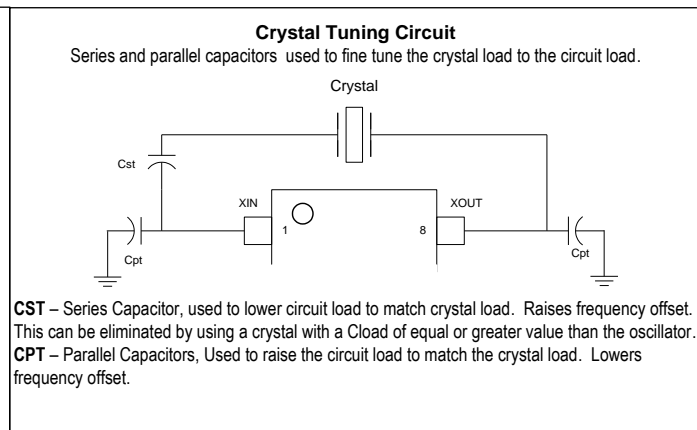
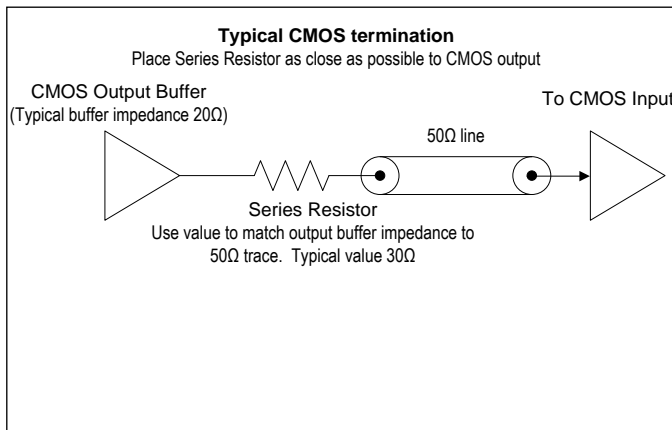

**Low Power, 1.62V to 3.63V, 10MHz to 40MHz, 1:3 Oscillator Fanout Buffer**
**ELECTRICAL SPECIFICATIONS**
**ABSOLUTE MAXIMUM RATINGS**

PARAMETERS	SYMBOL	MIN.	MAX.	UNITS
Supply Voltage Range	$V_{DD}$	-0.5	4.6	V
Input Voltage Range	$V_I$	-0.5	$V_{DD}+0.5$	V
Output Voltage Range	$V_O$	-0.5	$V_{DD}+0.5$	V
Storage Temperature	$T_S$	-65	150	°C
Ambient Operating Temperature*		-40	85	°C

Exposure of the device under conditions beyond the limits specified by Maximum Ratings for extended periods may cause permanent damage to the device and affect product reliability. These conditions represent a stress rating only, and functional operations of the device at these or any other conditions above the operational limits noted in this specification is not implied. \*Operating temperature is guaranteed by design. Parts are tested to commercial grade only.

**AC SPECIFICATIONS**

PARAMETERS	CONDITIONS	MIN.	TYP.	MAX.	UNITS
Crystal Input Frequency	Fundamental Crystal	10		40	MHz
Settling Time	At power-up ( $V_{DD} \geq 1.62V$ )			5	ms
Output Enable Time	OE Function; $T_a=25^\circ C$ , 10pF Load			10	ns
$V_{DD}$ Sensitivity	Frequency vs. $V_{DD}$ , $\pm 10\%$	-1		1	ppm
Output Rise Time	15pF Load, 10/90% $V_{DD}$ , 3.3V		2	3	ns
Output Fall Time	15pF Load, 90/10% $V_{DD}$ , 3.3V		2	3	ns
Output to Output Skew	Under all conditions			250	ps
Duty Cycle	Under all conditions	45	50	55	%

**DC SPECIFICATIONS**

PARAMETERS	SYMBOL	CONDITIONS	MIN	TYP	MAX	UNITS
Supply Current, Dynamic	$I_{DD}$	$V_{DD} = 3.3V$ , 25MHz, No Load		4		mA
		$V_{DD} = 2.5V$ , 25MHz, No Load		3		mA
		$V_{DD} = 1.8V$ , 25MHz, No Load		2		mA
Supply Current, Standby	$I_{DD\_SB}$	OE Pin Pulled Low, 25MHz, 3.3V			0.6	mA
Operating Voltage	$V_{DD}$		1.62		3.63	V
Output Low Voltage	$V_{OL}$	$I_{OL} = +12mA$ , 3.3V			0.4	V
Output High Voltage	$V_{OH}$	$I_{OH} = -12mA$ , 3.3V	2.4			V
Output Current	$I_{OSD}$	$V_{OL} = 0.4V$ , $V_{OH} = 2.4V$	12			mA

**Low Power, 1.62V to 3.63V, 10MHz to 40MHz, 1:3 Oscillator Fanout Buffer**
**CRYSTAL SPECIFICATIONS**

PARAMETERS	SYMBOL	MIN.	TYP.	MAX.	UNITS
Fundamental Crystal Resonator Frequency	$F_{XIN}$	10		40	MHz
Crystal Loading Rating	$C_{L(xtal)}$		8.5		pF
Maximum Sustainable Drive Level				200	$\mu$ W
Operating Drive Level			50		$\mu$ W
Crystal Shunt Capacitance	$C_0$			3	pF
Effective Series Resistance	ESR			30	$\Omega$

**PACKAGE DRAWINGS (GREEN PACKAGE COMPLIANT)**
**SOP-8L**

Symbol	Dimension in MM	
	Min.	Max.
A	1.35	1.75
A1	0.10	0.25
A2	1.25	1.50
B	0.33	0.53
C	0.19	0.27
D	4.80	5.00
E	3.80	4.00
H	5.80	6.20
L	0.40	0.89
e	1.27 BSC	

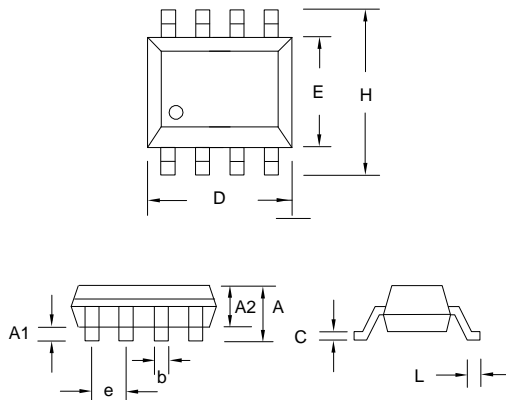

Low Power, 1.62V to 3.63V, 10MHz to 40MHz, 1:3 Oscillator Fanout Buffer

## ORDERING INFORMATION (GREEN PACKAGE COMPLIANT)

**For part ordering, please contact our Sales Department:**

2180 Fortune Drive, San Jose, CA 95131, USA

Tel: (408) 944-0800 Fax: (408) 474-1000

### PART NUMBER

The order number for this device is a combination of the following:  
Part number, Package type and Operating temperature range

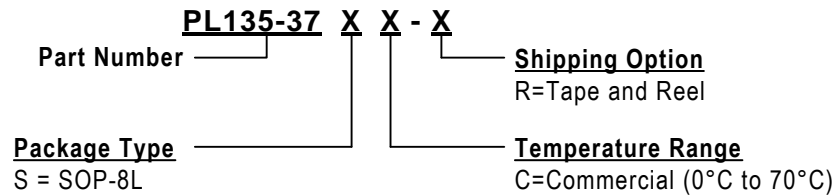

Part/Order Number	Marking	Package Option
PL135-37SC-R	P135-37 SC LLLLL	8-Pin SOP-8L (Tape and Reel)

\*Note: LLLLL designates lot number

Micrel Inc., reserves the right to make changes in its products or specifications, or both at any time without notice. The information furnished by Micrel is believed to be accurate and reliable. However, Micrel makes no guarantee or warranty concerning the accuracy of said information and shall not be responsible for any loss or damage of whatever nature resulting from the use of, or reliance upon this product.

**LIFE SUPPORT POLICY:** Micrel's products are not authorized for use as critical components in life support devices or systems without the express written approval of the President of Micrel Inc.

## Looking for pricing, stock, or lifecycle information?

Click below to explore more details on WIN SOURCE:

- ⊖ [View PL135-37SC-R on WIN SOURCE](#)
- ⊖ [Microchip Technology](#) Information

## Optimize Your Supply Chain with WIN SOURCE Solutions

- ✓ Global Sourcing Solution
- ✓ Obsolete Management
- ✓ Cost Control Management
- ✓ Shortage Management
- ✓ Alternative Solution
- ✓ Excess Inventory Management