



**THE DATASHEET OF
LTC6115IMS#PBF**



High Voltage High Side Current and Voltage Sense

FEATURES

Current Sense

- Supply Range: 5V to 100V
- Low Offset Voltage: $\pm 500\mu\text{V}$ (Maximum)
- 1 μs Response Time
- Gain Configurable with 2 Resistors
- Low Input Bias Current: 170nA (Maximum)
- PSRR: 118dB (Minimum)
- Low Supply Current: 250 μA

Voltage Sense

- Voltage Sense Range: 0V to 100V
- Precision 1M Ω Resistor Divider
- Low Total Gain Error: $\pm 0.15\%$ (Maximum)
- Supply Voltage Range: 2.7V to 5.5V
- Low Supply Current: 57 μA
- Operating Temperature Range: -40°C to 125°C
- AEC-Q100 Qualified for Automotive Applications

APPLICATIONS

- Current Shunt Measurement
- Battery Monitoring
- Power Management
- Automotive Sensing and Control
- Industrial Monitoring

DESCRIPTION

The LTC[®]6115 is a versatile combination of a high voltage, high side current sense amplifier and a voltage sense amplifier. Design flexibility is provided by the excellent device characteristics: $\pm 500\mu\text{V}$ maximum offset voltage for current sense and maximum $\pm 0.15\%$ voltage sense total gain error.

The current sensing part of the LTC6115 monitors current by sensing the voltage across an external sense resistor. The sensed voltage is converted to an output current which can then be translated to a voltage by an external resistor, R_{OUT} . Due to its fast response, it is a perfect choice for load current warning and shut-off protection control.

The LTC6115 also includes an internal 1M Ω resistor divider and a precision voltage amplifier for accurate voltage monitoring. The resistor attenuation of 40 enables sensing of up to 100V on the V_{IN} pin, making it suitable for precision high voltage monitoring in telecommunications, industrial and automotive applications. The full-scale output voltage can be configured by external gain resistors to maximize use of the amplifier's rail-to-rail output. The LTC6115 is available in a 12-lead MSOP package.

All registered trademarks and trademarks are the property of their respective owners.

TYPICAL APPLICATION

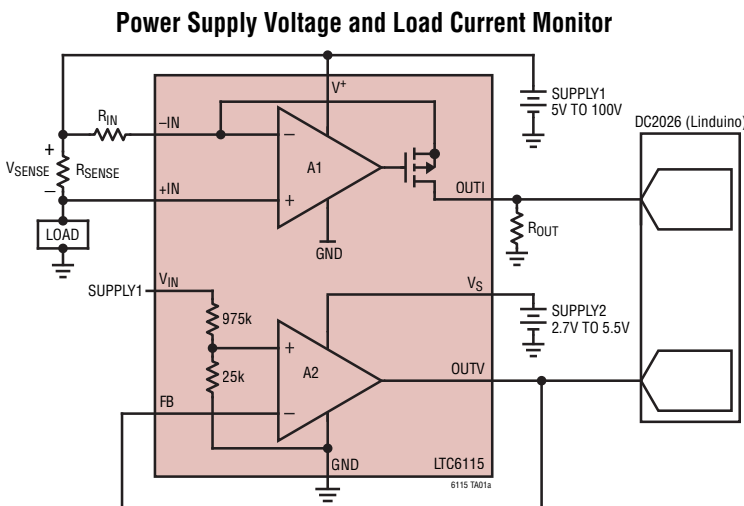

Voltage and Current Across Swept R_{LOAD} ,
Sampled by Linduino™ 10-Bit ADC

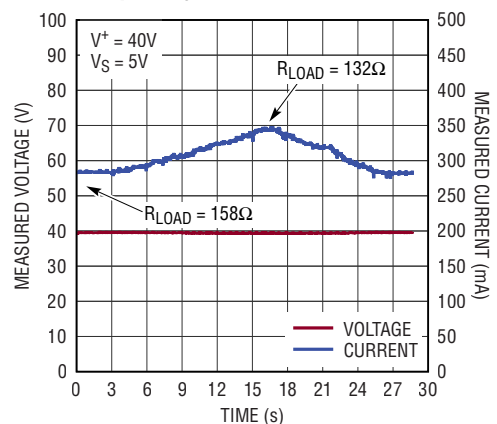

LTC6115

ABSOLUTE MAXIMUM RATINGS

(Note 1)

Total Supply Voltage	
V^+ to GND	105V
V_S to GND	6V
Input Voltage (V_{IN} Pin)	105V
Minimum $-IN$ Pin Voltage	($V^+ - 4V$)
FB Pin Voltage	GND – 0.3V to $V_S + 0.3V$
Input Current (+IN, $-IN$, FB Pins)	$\pm 10mA$
Maximum Output Voltage (OUTI Pin)	9V
Output Short-Circuit Duration (to GND)	Indefinite
Operating Temperature Range (Note 2)	
LTC6115I	$-40^\circ C$ to $85^\circ C$
LTC6115H	$-40^\circ C$ to $125^\circ C$
Specified Temperature Range (Note 3)	
LTC6115I	$-40^\circ C$ to $85^\circ C$
LTC6115H	$-40^\circ C$ to $125^\circ C$
Storage Temperature Range	$-65^\circ C$ to $150^\circ C$
Lead Temperature (Soldering, 10 sec)	$300^\circ C$

PIN CONFIGURATION

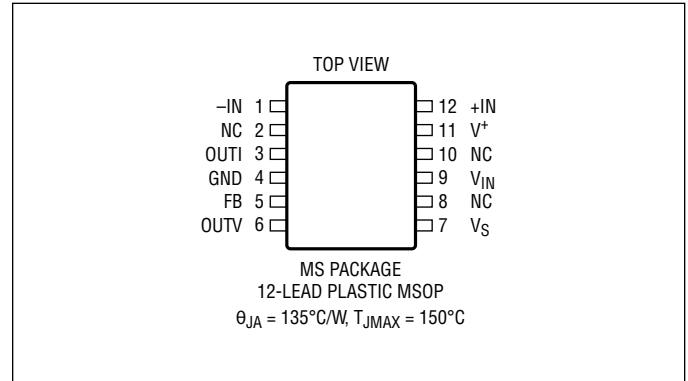

ORDER INFORMATION

TUBE	TAPE AND REEL	PART MARKING	PACKAGE DESCRIPTION	TEMPERATURE RANGE
LTC6115IMS#PBF	LTC6115IMS#TRPBF	6115	12-Lead Plastic MSOP	$-40^\circ C$ to $85^\circ C$
LTC6115HMS#PBF	LTC6115HMS#TRPBF	6115	12-Lead Plastic MSOP	$-40^\circ C$ to $125^\circ C$

AUTOMOTIVE PRODUCTS**

LTC6115HMS#WPBF	LTC6115HMS#WTRPBF	6115	12-Lead Plastic MSOP	$-40^\circ C$ to $125^\circ C$
-----------------	-------------------	------	----------------------	--------------------------------

Consult ADI Marketing for parts specified with wider operating temperature ranges.

[Tape and reel specifications](#). Some packages are available in 500 unit reels through designated sales channels with #TRMPBF suffix.

**Versions of this part are available with controlled manufacturing to support the quality and reliability requirements of automotive applications. These models are designated with a #W suffix. Only the automotive grade products shown are available for use in automotive applications. Contact your local Analog Devices account representative for specific product ordering information and to obtain the specific Automotive Reliability reports for these models.

ELECTRICAL CHARACTERISTICS The ● denotes the specifications which apply over the full specified temperature range, otherwise specifications are at $T_A = 25^\circ C$. $R_{IN} = 100\Omega$, $R_{OUT} = 10k\Omega$, $V_{SENSE^+} = V^+$ (Note 4), $5V \leq V^+ \leq 100V$, $V_{IN} = 20V$, unless otherwise noted.

SYMBOL	PARAMETER	CONDITIONS	MIN	TYP	MAX	UNITS
CURRENT SENSE						
	Supply Voltage Range (V^+)		●	5	100	V
V_{OS}	Input Offset Voltage (+IN, $-IN$)	$V_{SENSE} = 5mV$, Gain = 100	●	± 85	± 500 ± 800	μV μV
$\Delta V_{OS}/\Delta T$	Input Offset Voltage Drift	$V_{SENSE} = 5mV$, Gain = 100	●	± 3		$\mu V/^\circ C$
I_B	Input Bias Current (+IN, $-IN$)	$R_{IN} = 1M\Omega$, $R_{OUT} = 1M\Omega$	●	85	170 245	nA nA
I_{OS}	Input Offset Current	$R_{IN} = 1M\Omega$	●	± 2	± 20	nA

Rev. B

ELECTRICAL CHARACTERISTICS

The ● denotes the specifications which apply over the full specified temperature range, otherwise specifications are at $T_A = 25^\circ\text{C}$. $R_{IN} = 100\Omega$, $R_{OUT} = 10k\Omega$, $V_{SENSE^+} = V^+$ (Note 4), $5V \leq V^+ \leq 100V$, $V_{IN} = 20V$, unless otherwise noted.

SYMBOL	PARAMETER	CONDITIONS	MIN	TYP	MAX	UNITS
$V_{SENSE(MAX)}$	Input Sense Voltage Full-Scale	Error < 1%, $R_{IN} = 1k\Omega$ (Note 5)	●	500		mV
PSRR	Power Supply Rejection Ratio (V^+)	$V^+ = 6V$ to 100V, $V_{SENSE} = 5mV$, Gain = 100 Measured at OUT1	●	118	140	dB
		$V^+ = 5V$ to 100V, $V_{SENSE} = 5mV$, Gain = 100 Measured at OUT1	●	110	133	dB
$V_{OUTI(MAX)}$	Maximum Output Voltage (OUTI)	$12V \leq V^+ \leq 100V$, $V_{SENSE} = 88mV$	●	8		V
		$V^+ = 5V$, $V_{SENSE} = 330mV$, $R_{IN} = 1k\Omega$, $R_{OUT} = 10k\Omega$	●	3		V
$V_{OUTI(MIN)}$	Minimum Output Voltage (OUTI)	$V_{SENSE} = 0V$, Gain = 100 (Note 6)	●	0	50	mV
I_{OUTI}	Maximum Output Current (OUTI)	$5V \leq V^+ \leq 100V$, $R_{OUT} = 2k\Omega$, $V_{SENSE} = 110mV$, Gain = 20	●	1		mA
t_r	Input Step Response (to 2.5V on a 5V Output Step)	$\Delta V_{SENSE} = 100mV$ Transient, $6V \leq V^+ \leq 100V$, Gain = 50 $V^+ = 5V$. Measured at OUT1		1		μs
BW	Signal Bandwidth (OUTI)	$I_{OUTI} = 200\mu A$, $R_{IN} = 100\Omega$, $R_{OUT} = 5k\Omega$		140		kHz
		$I_{OUTI} = 1mA$, $R_{IN} = 100\Omega$, $R_{OUT} = 5k\Omega$		200		kHz
I_{V^+}	Supply Current (V^+)	$V^+ = 5V$, $I_{OUT} = 0$, $R_{IN} = 1M\Omega$	●	240	450	μA
		$V^+ = 6V$, $I_{OUT} = 0$, $R_{IN} = 1M\Omega$	●	250	475	μA
		$V^+ = 12V$, $I_{OUT} = 0$, $R_{IN} = 1M\Omega$	●	260	500	μA
		$V^+ = 100V$, $I_{OUT} = 0$, $R_{IN} = 1M\Omega$	●	400	640	μA

VOLTAGE SENSE, $V_S = 3V$

	Supply Voltage Range (V_S)	Guaranteed by the PSRR Test	●	2.7	5.5	V
	V_{IN} Voltage Range	Referred to GND		0	60	V
ΔG	Total Gain Error at $V_{IN} = 60V$	No Load	●	0.04	± 0.15	%
ΔG	Total Gain Error at $V_{IN} = 5V$	No Load	●	0.04	± 0.20	%
	Input Resistor Value	Measured from V_{IN} to GND	●	0.85	1	$1.15 M\Omega$
e_{nP-P}	Input Noise Voltage (V_{IN})	0.1Hz to 10Hz, V_{IN} Referred, $V_{IN} = 15V$, $A_V = 1$		60		μV_{P-P}
e_n	Input Noise Voltage Density (V_{IN}) (Note 7)	$f = 1kHz$		1.26		$\mu V/\sqrt{Hz}$
		$f = 10kHz$		1.13		$\mu V/\sqrt{Hz}$
i_n	Input Noise Current Density (Note 8)			1		fA/\sqrt{Hz}
PSRR	Power Supply Rejection Ratio (V_S)	$V_S = 2.7V$ to 5.5V, $V_{IN} = 20V$. Measured at OUTV	●	95	115	dB
V_{OH}	Output Voltage, High ($V_S - OUTV$)	No Load	●	1	2	mV
		$I_{SOURCE} = 0.2mA$	●		30	mV
		$I_{SOURCE} = 2mA$	●		300	mV
V_{OL}	Output Voltage, Low (OUTV – GND)	No Load	●	1	2	mV
		$I_{SINK} = 0.2mA$	●		25	mV
		$I_{SINK} = 2mA$	●		220	mV
I_{SC}	Output Short-Circuit Current (OUTV)	Source	●	9	12	mA
		Sink	●	6.5		mA
GBW	Gain-Bandwidth Product (OUTV) ($f_{TEST} = 20kHz$)		●	8	13	mA
			●	6		mA
			●	300	530	kHz
			●	270		

ELECTRICAL CHARACTERISTICS

The ● denotes the specifications which apply over the full specified temperature range, otherwise specifications are at $T_A = 25^\circ\text{C}$. $R_{IN} = 100\Omega$, $R_{OUT} = 10k\Omega$, $V_{SENSE^+} = V^+$ (Note 4), $5V \leq V^+ \leq 100V$, $V_{IN} = 20V$, unless otherwise noted.

SYMBOL	PARAMETER	CONDITIONS	MIN	TYP	MAX	UNITS
t_S	Settling Time 0.1%	$A_V = 1$, 1V Output Step		25		μs
I_S	Amplifier Supply Current (V_S)	No Load, $V_{IN} = 20V$		55	76 85	μA μA
VOLTAGE SENSE, $V_S = 5V$						
	Supply Voltage Range (V_S)	Guaranteed by the PSRR Test	●	2.7	5.5	V
	V_{IN} Voltage Range	Referred to GND		0	100	V
ΔG	Total Gain Error at $V_{IN} = 100V$	No Load	●	0.03	± 0.15	%
ΔG	Total Gain Error at $V_{IN} = 5V$	No Load	●	0.03	± 0.20 ± 0.24	% %
	Input Resistor Value	Measured from V_{IN} to GND	●	0.85	1 1.15	$M\Omega$
I_B (FB Pin)	Input Bias Current	$V_{IN} = 100V$ -40°C to 85°C -40°C to 125°C	● ● ●	3	100 300 2000	μA μA μA
$e_{n\text{-P-P}}$	Input Noise Voltage	0.1Hz to 10Hz, V_{IN} Referred, $V_{IN} = 15V$, $A_V = 1$		60		$\mu\text{V}_{\text{P-P}}$
e_n	Input Noise Voltage Density (V_{IN}) (Note 7)	$f = 1\text{kHz}$ $f = 10\text{kHz}$		1.26 1.13		$\mu\text{V}/\sqrt{\text{Hz}}$ $\mu\text{V}/\sqrt{\text{Hz}}$
i_n	Input Noise Current Density (Note 8)			1		$\text{fA}/\sqrt{\text{Hz}}$
PSRR	Power Supply Rejection Ratio (V_S)	$V_S = 2.7V$ to $5.5V$, $V_{IN} = 20V$, Measured at OUTV	●	95	115	dB
V_{OH}	Output Voltage, High ($V_S - \text{OUTV}$)	No Load $I_{\text{SOURCE}} = 0.5\text{mA}$ $I_{\text{SOURCE}} = 5\text{mA}$	● ● ●	1	2 45 450	mV mV mV
V_{OL}	Output Voltage, Low ($\text{OUTV} - \text{GND}$)	No Load $I_{\text{SINK}} = 0.5\text{mA}$ $I_{\text{SINK}} = 5\text{mA}$	● ● ●	1	2 35 350	mV mV mV
I_{SC}	Output Short-Circuit Current (OUTV)	Source	●	18 17	27	mA mA
		Sink	●	16 14	27	mA mA
SR	Slew Rate	$A_V = 1$	●	0.035	0.06	$\text{V}/\mu\text{s}$
GBW	Gain-Bandwidth Product (OUTV) ($f_{\text{TEST}} = 20\text{kHz}$)	$R_L = 100k\Omega$	●	300 270	530	kHz
t_S	Settling Time 0.1%	$A_V = 1$, 1V Output Step		25		μs
I_S	Amplifier Supply Current (V_S)	No Load, $V_{IN} = 20V$	●	57	76 85	μA μA

Note 1: Stresses beyond those listed under Absolute Maximum Ratings may cause permanent damage to the device. Exposure to any Absolute Maximum Rating condition for extended periods may affect device reliability and lifetime.

Note 2: The LTC6115I is guaranteed functional over the operating temperature range of -40°C to 85°C . The LTC6115H is guaranteed functional over the operating temperature range of -40°C to 125°C .

Note 3: The LTC6115I is guaranteed to meet specified performance from -40°C to 85°C . The LTC6115H is guaranteed to meet specified performance from -40°C to 125°C .

Note 4: V_{SENSE} is the voltage developed across the external sense resistor R_{SENSE} . V_{SENSE^+} is the voltage at the high side of R_{SENSE} . See the Typical Application drawing on the front page.

Note 5: $R_{OUT} = 10k\Omega$ for $7V \leq V_S \leq 100V$, $R_{OUT} = 2k\Omega$ for $V_S = 5V, 6V$.

Note 6: Current sense minimum output voltage is measured with 0V shunt voltage and is limited by the maximum positive offset voltage.

Note 7: This includes the noise of the resistor divider and amplifier A2, referred to the V_{IN} pin. See the section on Noise Sources under Applications Information: Voltage Sense for more details.

Note 8: Current noise is calculated from:

$$i_n = \sqrt{2qI_B}, \text{ where } q = 1.6 \cdot 10^{-19} \text{ Coulombs.}$$

CURRENT SENSE TYPICAL PERFORMANCE CHARACTERISTICS

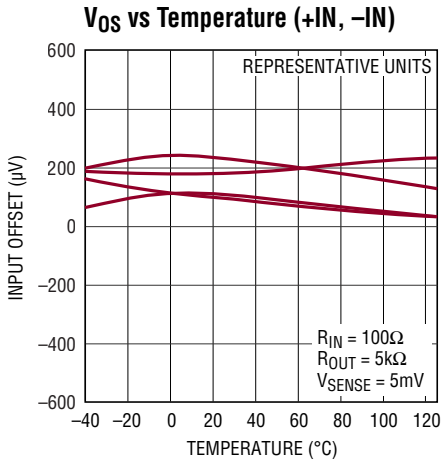

6115 G01

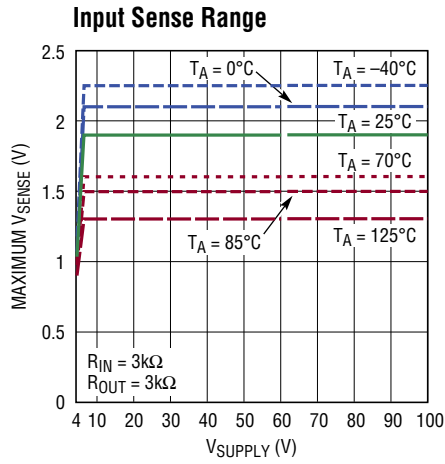

6115 G02

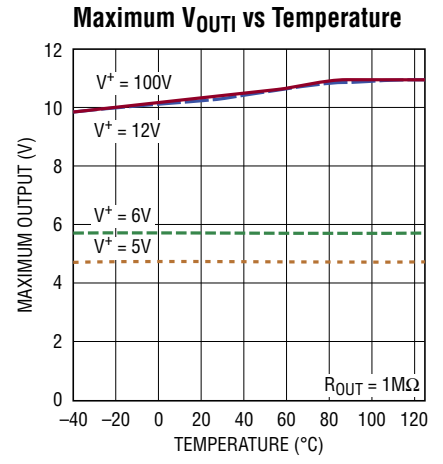

6115 G03

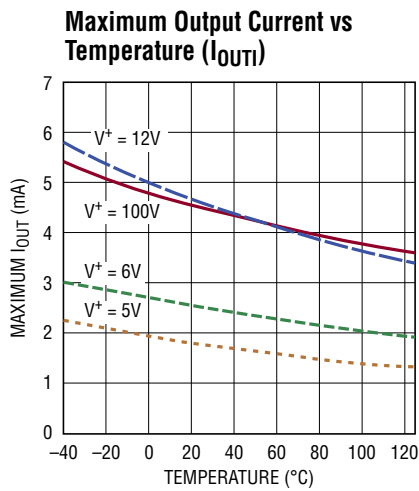

6115 G04

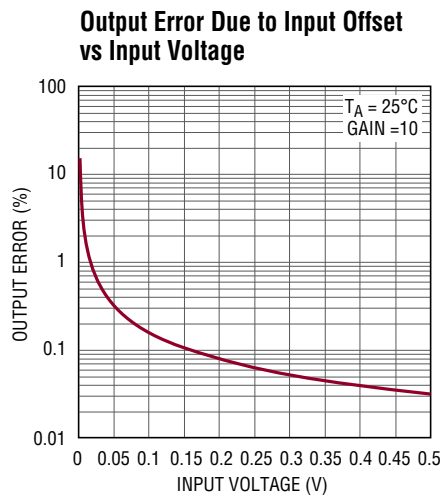

6115 G05

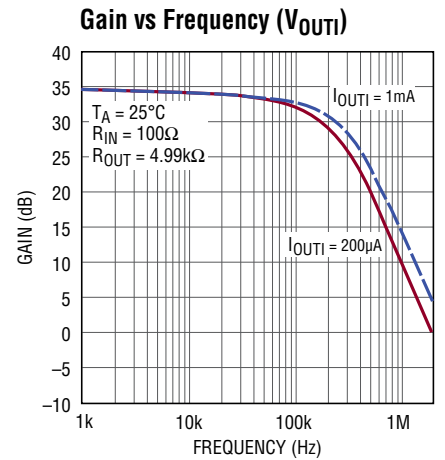

6115 G06

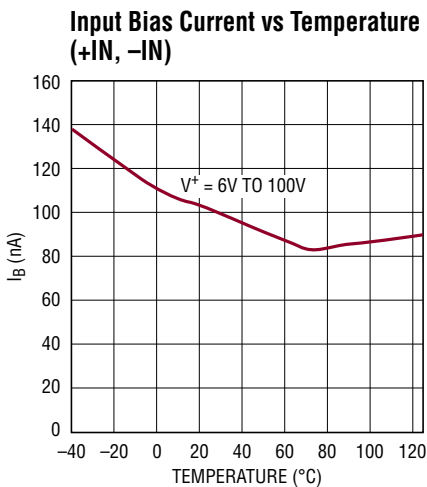

6115 G07

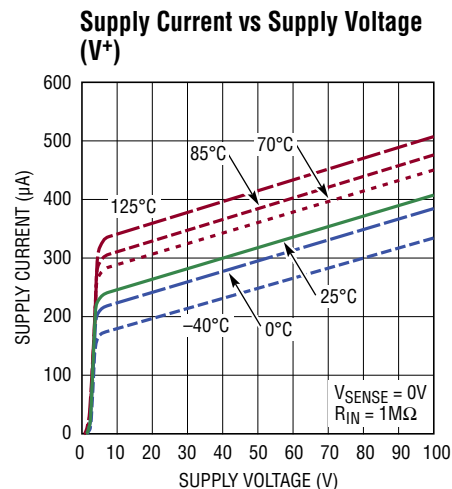

6115 G08

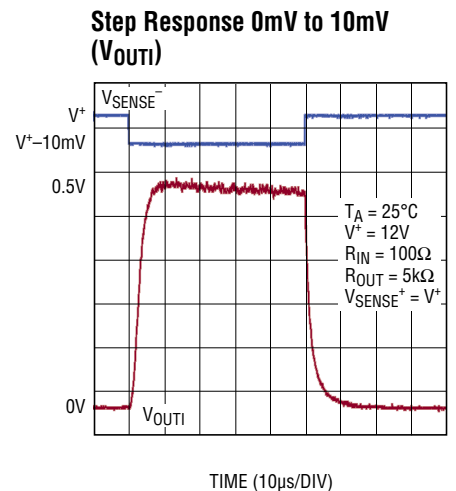

6115 G09

CURRENT SENSE TYPICAL PERFORMANCE CHARACTERISTICS

Step Response 10mV to 20mV (V_{OUTI})

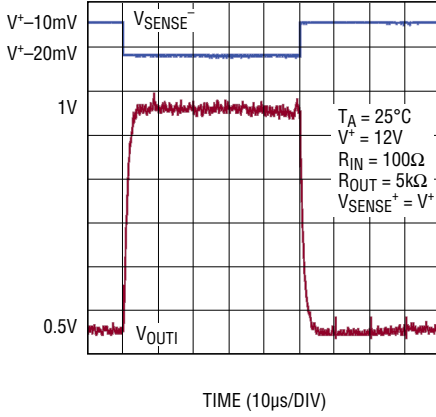

6115 G10

Step Response 100mV (V_{OUTI})

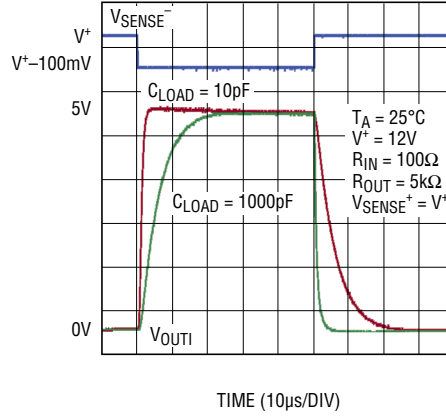

6115 G11

Step Response 100mV (V_{OUTI})

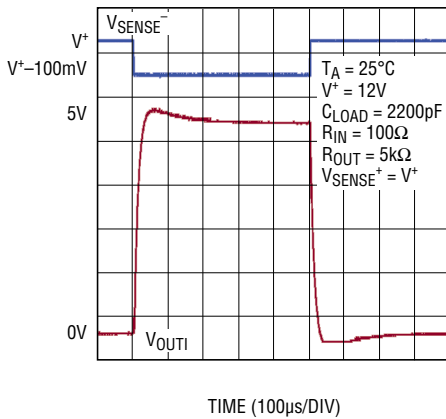

6115 G12

Step Response Rising Edge (V_{OUTI})

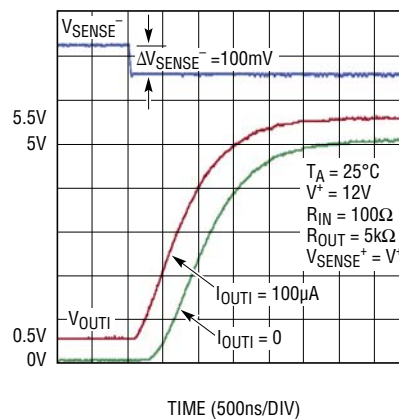

6115 G13

Step Response Falling Edge (V_{OUTI})

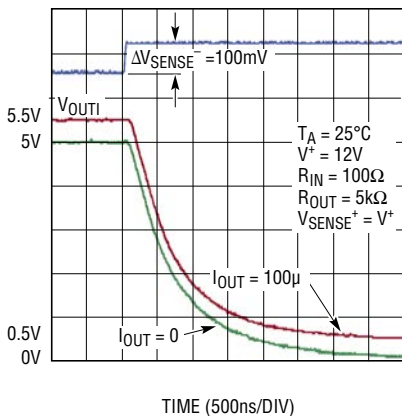

6115 G14

PSRR vs Frequency (V_{OUTI})

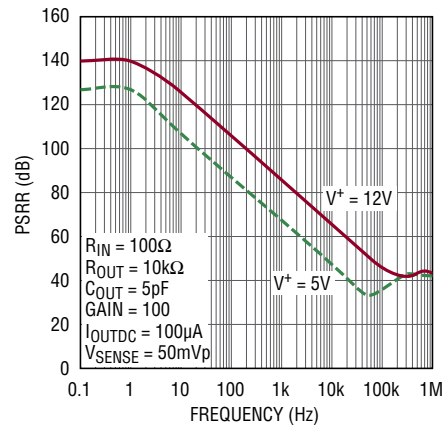

6115 G15

VOLTAGE SENSE TYPICAL PERFORMANCE CHARACTERISTICS

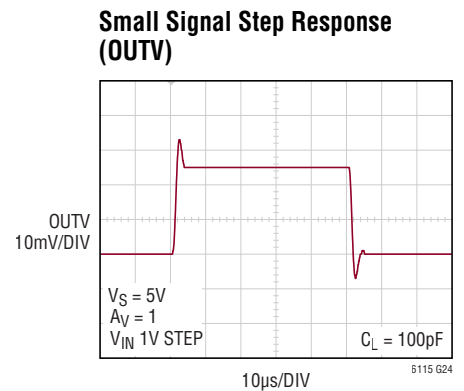
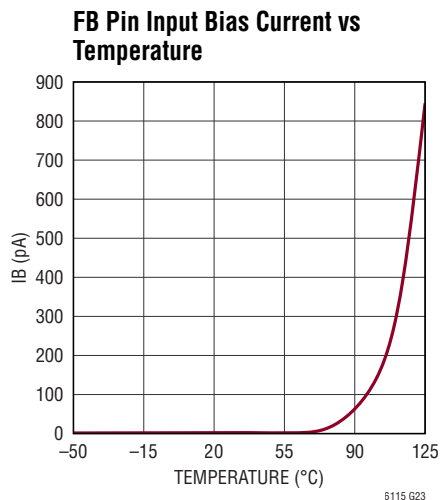
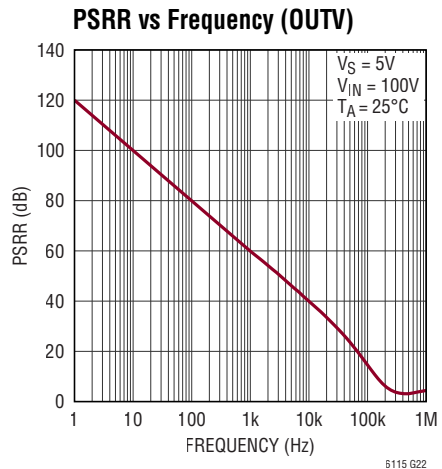
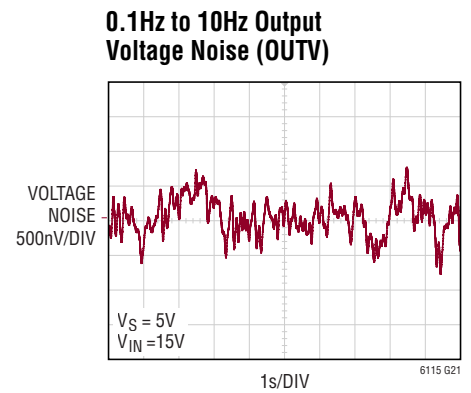
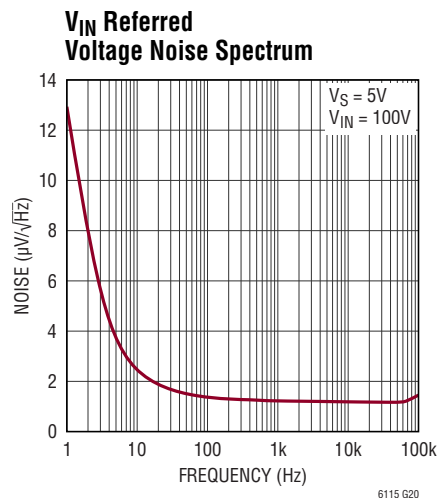
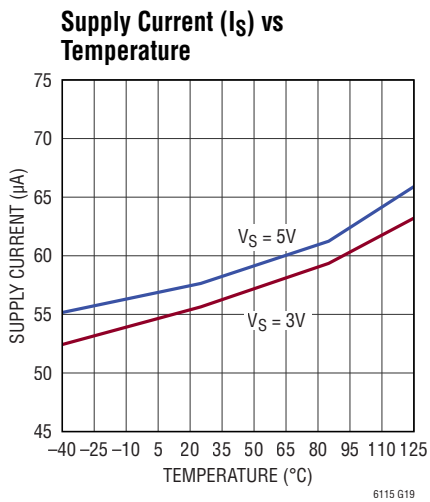
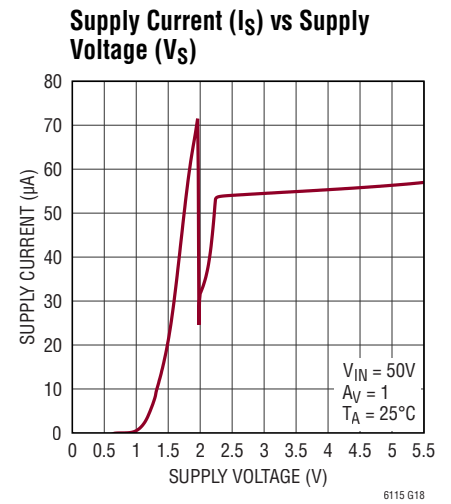
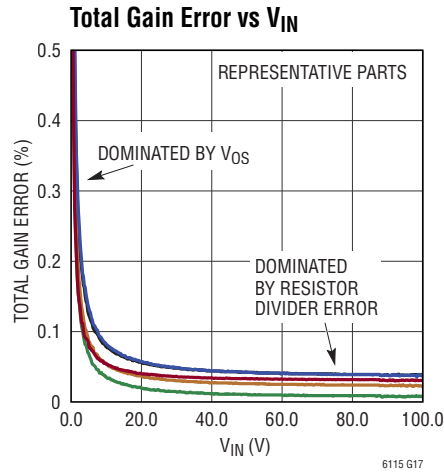
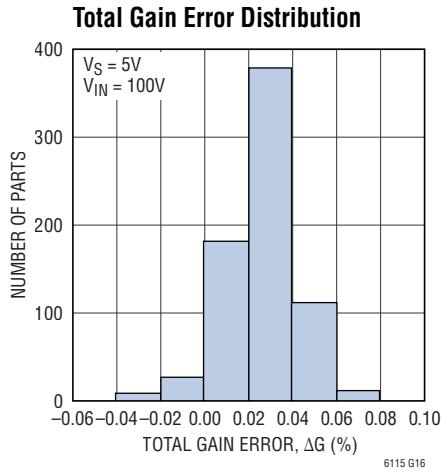

VOLTAGE SENSE TYPICAL PERFORMANCE CHARACTERISTICS

Step Response 20V to 40V (OUTV)

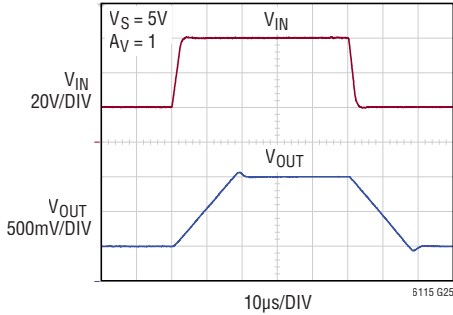

Small Signal Overshoot (OUTV) vs Load Capacitance

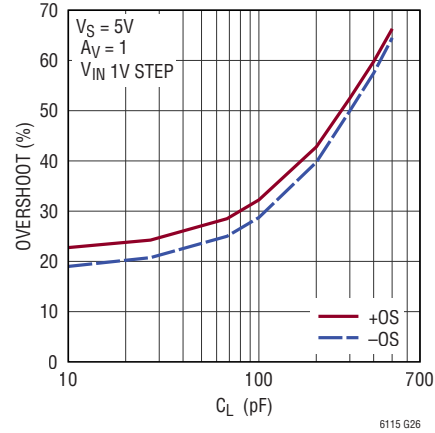

Output Voltage Swing vs Load Current (OUTV)

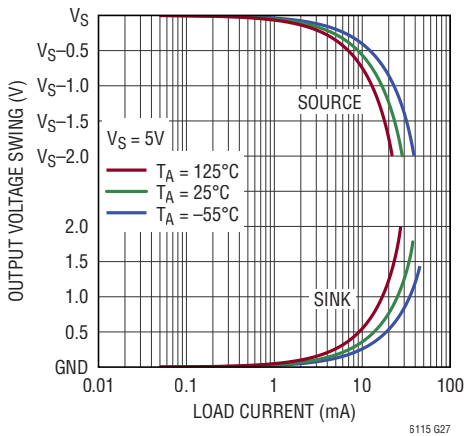

Short Circuit Current (OUTV) vs Temperature

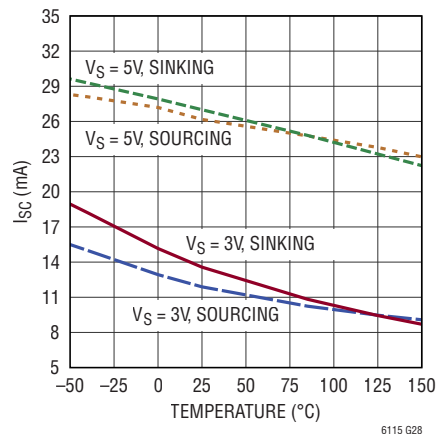

Output Impedance vs Frequency (OUTV)

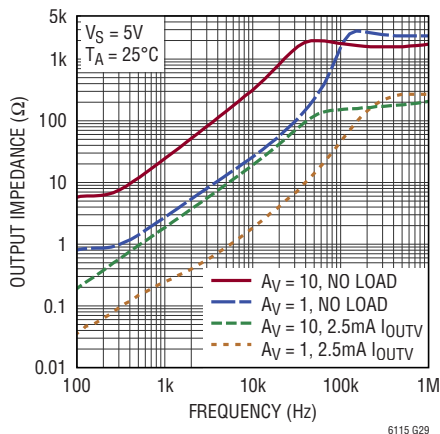

Through Gain (OUTV/VIN) vs Frequency

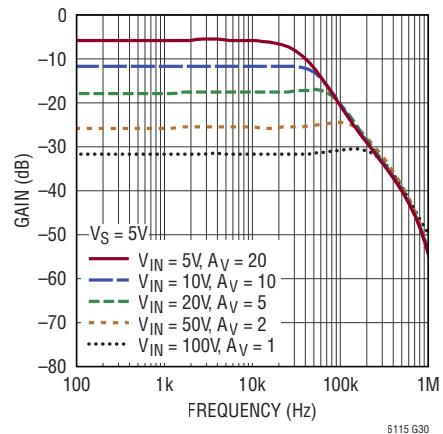

PIN FUNCTIONS

-IN (Pin 1): Inverting Input of the Current Sense Amplifier. The internal current sense amplifier will drive -IN to the same potential as +IN.

OUTI (Pin 3): Current Output of Current Sense Amplifier. OUTI will source a current that is proportional to the sense voltage into an external resistor.

GND (Pin 4): Ground.

FB (Pin 5): Voltage Sense Amplifier Inverting Input.

OUTV (Pin 6): Voltage Sense Amplifier Output Voltage.

+IN (Pin 12): Noninverting Input of the Current Sense Amplifier. Must be tied to the system load end of the sense resistor, either directly or through a resistor.

V+ (Pin 11): Positive Supply Pin for Current Sense Circuit. Supply current for the current sense circuit is drawn through this pin.

V_{IN} (Pin 9): Voltage Sense Amplifier Input Voltage.

V_S (Pin 7): Voltage Sense Amplifier Positive Supply.

NC (Pins 2, 8, 10): Not internally connected.

BLOCK DIAGRAM

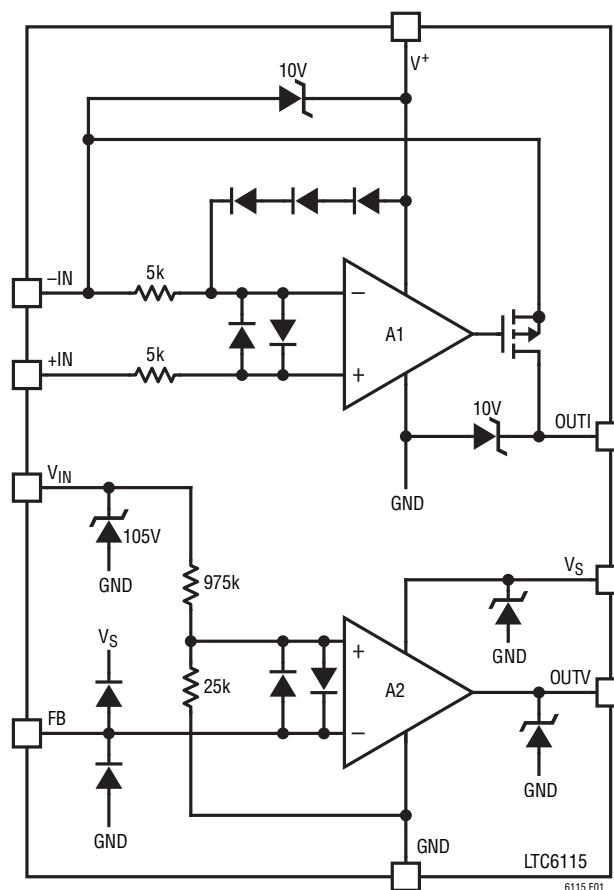

Figure 1. LTC6115 Block Diagram

APPLICATIONS INFORMATION: CURRENT SENSE

The LTC6115 high side current sense amplifier (Figure 1, Amplifier A1) provides accurate monitoring of current through an external user-selected sense resistor. The sense voltage is amplified by a user-selected gain and level shifted from the positive power supply to a ground-referred output current. The output signal is analog and may be used as is or processed with an output filter.

Theory of Operation

An internal sense amplifier loop forces $-IN$ to have the same potential as $+IN$. Connecting an external resistor, R_{IN} , between $-IN$ and V^+ forces a potential across R_{IN} that is the same as the sense voltage across R_{SENSE} . A corresponding current, V_{SENSE}/R_{IN} , will flow through R_{IN} . The high impedance inputs of the sense amplifier will not conduct this input current, so it will flow through the internal MOSFET to the output pin.

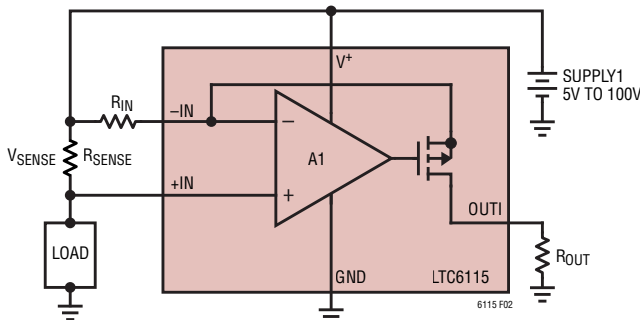

Figure 2.

The output current can be transformed into a voltage by adding a resistor from $OUTI$ to GND . The output voltage is then $V_{OUTI} = I_{OUTI} \cdot R_{OUTI}$.

Table 1. Useful Gain Configurations

GAIN	R_{IN} (Ω)	R_{OUT} (Ω)	V_{SENSE} AT $V_{OUT} = 5V$	I_{OUT} AT $V_{OUT} = 5V$
20	499	10k	250mV	500 μ A
50	200	10k	100mV	500 μ A
100	100	10k	50mV	500 μ A

Selection of External Current Sense Resistor

The external sense resistor, R_{SENSE} , has a significant effect on the function of a current sensing system and must be chosen with care.

First, the power dissipation in the resistor should be considered. The system load current will cause both heat and voltage drop in R_{SENSE} . As a result, the sense resistor should be as small as possible while still providing the input dynamic range required by the measurement. Note that input dynamic range is the difference between the maximum input signal and the minimum accurately reproduced signal, and is limited primarily by input DC offset of the internal current sense amplifier. In addition, R_{SENSE} must be small enough that V_{SENSE} does not exceed the maximum V_{SENSE} input voltage specified by the LTC6115 current sense amplifier, even under peak load conditions. As an example, an application may require that the maximum sense voltage be 100mV. If this application is expected to draw 2A at peak load, R_{SENSE} should be no more than 50m Ω .

Once the maximum R_{SENSE} value is determined, the minimum sense resistor value will be set by the resolution or dynamic range required. The minimum signal that can be accurately represented by this sense amp is limited by the input offset. As an example, the LTC6115 current sense amplifier has a typical input offset of 85 μ V. If the minimum current is 20mA, a sense resistor of 5m Ω will set V_{SENSE} to 100 μ V. This is only slightly higher than the input offset. A larger sense resistor will reduce the error due to offset by increasing the sense voltage for a given load current.

Choosing a 50m Ω R_{SENSE} will maximize the dynamic range and provide a system that has 100mV across the sense resistor at peak load (2A), while an input offset of 85 μ V causes an error equivalent to only 1.7mA of load current. Peak power dissipation in the sense resistor will be 200mW. If a 5m Ω sense resistor is employed, then the effective current error is 17mA, while the peak sense voltage is reduced to 10mV at 2A, dissipating only 20mW.

The low offset and corresponding large dynamic range of the LTC6115 make it more flexible than other solutions in this respect. The 85 μ V typical offset gives 60dB of dynamic range for a sense voltage that is limited to 85mV maximum, and over 75dB of dynamic range if the rated input maximum of 500mV is allowed.

APPLICATIONS INFORMATION: CURRENT SENSE

Sense Resistor Connection

Kelvin connection of the $-IN$ and $+IN$ inputs to the sense resistor should be used in all but the lowest power applications. Solder connections and PC board interconnections that carry high current can cause significant error in measurement due to their relatively large resistances. One $10\text{mm} \times 10\text{mm}$ square trace of one-ounce copper is approximately $0.5\text{m}\Omega$. A 1mV error can be caused by as little as 2A flowing through this small interconnect. This will cause a 1% error in a 100mV signal. A 10A load current in the same interconnect will cause a 5% error for the same 100mV signal. By isolating the sense traces from the high current paths, this error can be reduced by orders of magnitude. A sense resistor with integrated Kelvin sense terminals will give the best results. Figure 3 illustrates the recommended method.

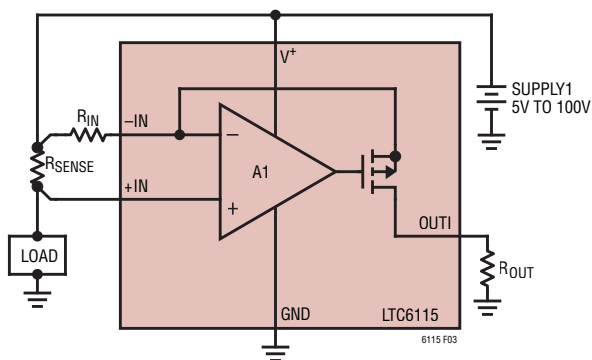

Figure 3. Kelvin Input Connection Preserves Accuracy Despite Large Load Current

Selection of External Input Resistor, R_{IN}

The external input resistor, R_{IN} , controls the transconductance of the current sense circuit. Since $I_{OUT1} = V_{SENSE}/R_{IN}$, transconductance $g_m = 1/R_{IN}$. For example, if $R_{IN} = 100$, then $I_{OUT1} = V_{SENSE}/100$, or $I_{OUT1} = 1\text{mA}$ for $V_{SENSE} = 100\text{mV}$.

R_{IN} should be chosen to allow the required resolution while limiting the output current. I_{OUT1} may be as much as 1mA . By setting R_{IN} such that the largest expected sense voltage gives $I_{OUT1} = 1\text{mA}$, then the maximum output dynamic range is available. Output dynamic range is limited by both the maximum allowed output current and the maximum allowed output voltage, as well as the

minimum practical output signal. If less dynamic range is required, then R_{IN} can be increased accordingly, reducing the maximum output current and power dissipation.

If low sense currents must be resolved accurately in a system that has very wide dynamic range, a larger R_{SENSE} may be used if the maximum current is limited in another way, such as with a Schottky diode across R_{SENSE} (Figure 4). This will reduce the high current measurement accuracy by limiting the result, while increasing the low current measurement resolution.

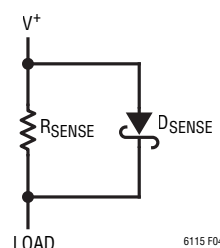

Figure 4. Shunt Diode Limits Maximum Input Voltage to Allow Better Low Input Resolution Without Overranging

This approach can be helpful in cases where occasional large burst currents may be ignored.

Care should be taken when designing the board layout for R_{IN} , especially for small R_{IN} values. All trace and interconnect impedances will increase the effective R_{IN} value, causing a gain error. In addition, internal device resistance will add approximately 0.2Ω to R_{IN} .

Selection of External Output Resistor, R_{OUT}

The output resistor, R_{OUT} , determines how the output current is converted to voltage. $V_{(OUT1)}$ is simply $I_{(OUT1)} \cdot R_{OUT}$.

In choosing an output resistor, the maximum output voltage must first be considered. If the circuit that is driven by the output does not limit the output voltage, then R_{OUT} must be chosen such that the maximum output voltage does not exceed the LTC6115 I_{OUT} maximum output voltage rating. If the following circuit is a buffer or ADC with limited input range, then R_{OUT} must be chosen so that $I_{OUT1(MAX)} \cdot R_{OUT}$ is less than the allowed maximum input range of this circuit.

APPLICATIONS INFORMATION: CURRENT SENSE

In addition, the output impedance is determined by R_{OUT} . If the circuit to be driven has high enough input impedance, then almost any useful output impedance will be acceptable. However, if the driven circuit has relatively low input impedance, or draws spikes of current, such as an ADC might do, then a lower R_{OUT} value may be required in order to preserve the accuracy of the output. As an example, if the input impedance of the driven circuit is 100 times R_{OUT} , then the accuracy of V_{OUT} will be reduced by 1% since:

$$\begin{aligned} V_{OUTI} &= I_{OUTI} \cdot \frac{R_{OUT} \cdot R_{IN(DRIVEN)}}{R_{OUT} + R_{IN(DRIVEN)}} \\ &= I_{OUTI} \cdot R_{OUT} \cdot \frac{100}{101} \\ &= 0.99 \cdot I_{OUTI} \cdot R_{OUT} \end{aligned}$$

Error Sources

The current sense circuit uses an amplifier and resistors to apply gain and level shift the result. The output is then dependent on the characteristics of the amplifier, such as gain and input offset, as well as resistor matching.

Ideally the circuit output is:

$$\begin{aligned} V_{OUTI} &= V_{SENSE} \cdot \frac{R_{OUT}}{R_{IN}} \\ V_{SENSE} &= R_{SENSE} \cdot I_{SENSE} \end{aligned}$$

In this case, the only error is due to resistor mismatch, which provides an error in gain only. However, offset voltage, bias current and finite gain in the amplifier cause additional errors.

Output Error, $E_{OUTI(VOS)}$, Due to the Amplifier DC Offset Voltage, V_{OS}

$$E_{OUTI(VOS)} = V_{OS} \cdot (R_{OUT}/R_{IN})$$

The DC offset voltage of the amplifier adds directly to the value of the sense voltage, V_{SENSE} . This is the dominant error of the system and it limits the available dynamic range. The section Selection of External Current Sense Resistor provides details.

Output Error, $E_{OUTI(I_{BIAS})}$, Due to the Bias Currents, I_{B+} and I_{B-}

The bias current I_{B+} flows into the positive input of the internal op amp. I_{B-} flows into the negative input.

$$E_{OUTI(I_{BIAS})} = R_{OUT}((I_{B+} \cdot (R_{SENSE}/R_{IN})) - I_{B-})$$

Since $I_{B+} \approx I_{B-} = I_{BIAS}$, if $R_{SENSE} \ll R_{IN}$ then,

$$E_{OUTI(I_{BIAS})} \approx -R_{OUT} \cdot I_{BIAS}$$

For instance if I_{BIAS} is 100nA and R_{OUT} is 1k Ω , the output error is 0.1mV.

Note that in applications where $R_{SENSE} \approx R_{IN}$, I_{B+} causes a voltage offset in R_{SENSE} that cancels the error due to I_{B-} and $E_{OUTI(I_{BIAS})} \approx 0$. In applications where $R_{SENSE} < R_{IN}$, the bias current error can be similarly reduced if an external resistor $R_{IN+} = (R_{IN} - R_{SENSE})$ is connected as shown in Figure 5.

Under both conditions:

$$\begin{aligned} E_{OUTI(I_{BIAS})} &= \pm R_{OUT} \cdot I_{OS} \\ I_{OS} &= I_{B+} - I_{B-} \end{aligned}$$

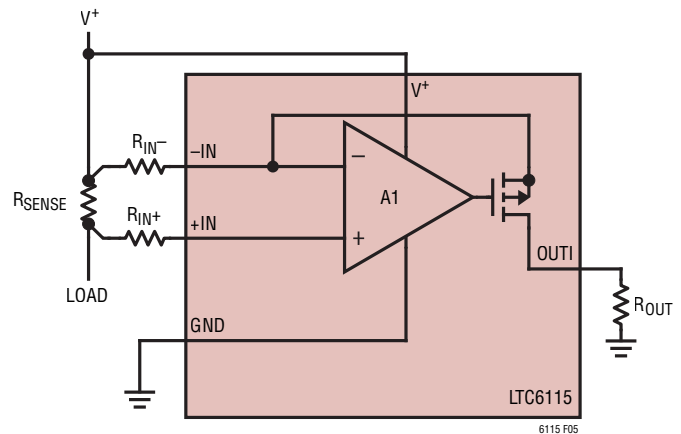

Figure 5. Second Input R Minimizes Error Due to Input Bias Current

If the offset current, I_{OS} , of the LTC6115 current sense amplifier is 2nA, the 100mV error above is reduced to 2mV. Adding R_{IN+} as described will maximize the dynamic range of the circuit. For less sensitive designs, R_{IN+} is not necessary.

APPLICATIONS INFORMATION: CURRENT SENSE

Example

If a circuit has an expected I_{SENSE} range of 1A to 1mA, and $(V_{\text{OUTI}}/I_{\text{SENSE}}) = 3\text{V}/1\text{A}$, then, from the Electrical Characteristics of the LTC6115 current sense amplifier, $R_{\text{SENSE}} \approx V_{\text{SENSE}(\text{MAX})}/I_{\text{SENSE}(\text{MAX})} = 500\text{mV}/1\text{A} = 500\text{m}\Omega$.

$$\text{Gain} = R_{\text{OUT}}/R_{\text{IN}} = V_{\text{OUTI}(\text{MAX})}/V_{\text{SENSE}(\text{MAX})} = 3\text{V}/500\text{mV} = 6.$$

If the maximum output current, I_{OUTI} , is limited to 1mA, R_{OUT} equals $3\text{V}/1\text{mA} \approx 3.01\text{k}\Omega$ (1% value) and $R_{\text{IN}} = 3\text{k}\Omega/6 \approx 499\Omega$ (1% value).

The output error due to DC offset is $\pm 510\mu\text{V}$ ($85\mu\text{V}$ typical \cdot gain of 6) and the error due to offset current, I_{OS} is $3\text{k}\Omega \cdot \pm 2\text{nA} = \pm 6\mu\text{V}$ (typical), provided $R_{\text{IN}+} = R_{\text{IN}-}$.

The maximum output error can therefore reach $\pm 516\mu\text{V}$ or 0.017% (-75dB) of the output full-scale. Considering the system input 60dB dynamic range ($I_{\text{SENSE}} = 1\text{mA}$ to 1A), the 70dB performance of the LTC6115 current sense amplifier makes this application feasible.

Output Error, E_{OUT} , Due to the Finite DC Open-Loop Gain, A_{OL} , of the LTC6115 Current Sense Amplifier

This error is inconsequential as the A_{OL} of the amplifier is very large.

Output Current Limitations Due to Power Dissipation

The current sense amplifier can deliver up to 1mA continuous current to the output pin. This current flows through R_{IN} and enters the current sense amplifier via the $-\text{IN}$ pin. The power dissipated in the current sense circuit due to the output signal is:

$$P_{\text{OUTI}} = (V_{-\text{IN}} - V_{\text{OUTI}}) \cdot I_{\text{OUTI}}$$

$$\text{Since } V_{-\text{IN}} \approx V^+, P_{\text{OUTI}} \approx (V^+ - V_{\text{OUTI}}) \cdot I_{\text{OUTI}}$$

There is also power dissipated due to the quiescent supply current:

$$P_{\text{Q}} = I_{\text{V}^+} \cdot V^+$$

The total power dissipated is the output dissipation plus the quiescent dissipation:

$$P_{\text{TOTAL}} = P_{\text{OUTI}} + P_{\text{Q}}$$

At maximum supply and maximum output current, the total power dissipation can exceed 100mW. This will cause significant heating of the die. In order to prevent damage to the circuit, the maximum expected dissipation in each application should be calculated. This number can be multiplied by the θ_{JA} value listed in the Pin Configuration section to find the maximum expected die temperature. This must not be allowed to exceed 150°C , or performance may be degraded.

As an example, if only the current sense is to run at 100V supply voltage on V^+ , with 1mA output current at 125°C :

$$\begin{aligned} P_{\text{Q}(\text{MAX})} &= I_{\text{V}^+(\text{MAX})} \cdot V^+(\text{MAX}) \\ &= 720\mu\text{A} \cdot 100\text{V} \\ &= 72\text{mW} \end{aligned}$$

$$\begin{aligned} P_{\text{OUT}(\text{MAX})} &= I_{\text{OUTI}} \cdot V^+(\text{MAX}) \\ &= 1\text{mA} \cdot 100\text{V} \\ &= 100\text{mW} \end{aligned}$$

$$\begin{aligned} T_{\text{RISE}} &= \theta_{\text{JA}} \cdot P_{\text{TOTAL}(\text{MAX})} \\ &= 135^\circ\text{C}/\text{W} \cdot 172\text{mW} \\ &= 23.2^\circ\text{C} \end{aligned}$$

$$\begin{aligned} T_{\text{MAX}} &= T_{\text{AMBIENT}} + T_{\text{RISE}} \\ &= 125^\circ\text{C} + 23.2^\circ\text{C} \\ &= 148.2^\circ\text{C} \end{aligned}$$

The junction temperature will thus be very close to 150°C , above the specified temperature range. In this case, the maximum output current should be reduced, which can be done by changing R_{IN} .

It is important to note that the current sense amplifier has been designed to provide at least 1mA to the output when required, and can deliver more depending on the conditions. Care must be taken to limit the maximum output current by proper choice of sense resistor and, if input fault conditions exist, external clamps.

APPLICATIONS INFORMATION: CURRENT SENSE

Output Filtering

The output voltage at pin OUT1 is simply $I_{OUT1} \cdot Z_{OUT1}$. This makes filtering straightforward. Any circuit may be used which generates the required Z_{OUT1} to get the desired filter response. For example, a capacitor in parallel with R_{OUT} will give a low pass response. This will reduce unwanted noise from the output, and may also be useful as a charge reservoir to keep the output steady while driving a switching circuit such as a multiplexer or ADC. This output capacitor in parallel with an output resistor will create a pole in the output response at:

$$f_{-3dB} = \frac{1}{2 \cdot \pi \cdot R_{OUT} \cdot C_{OUT}}$$

Useful Equations

$$\text{Input Voltage: } V_{SENSE} = I_{SENSE} \cdot R_{SENSE}$$

$$\text{Voltage Gain: } \frac{V_{OUT1}}{V_{SENSE}} = \frac{R_{OUT}}{R_{IN}}$$

$$\text{Current Gain: } \frac{I_{OUT1}}{I_{SENSE}} = \frac{R_{SENSE}}{R_{IN}}$$

$$\text{Transconductance: } \frac{I_{OUT}}{V_{SENSE}} = \frac{1}{R_{IN}}$$

$$\text{Transimpedance: } \frac{V_{OUT}}{I_{SENSE}} = R_{SENSE} \cdot \frac{R_{OUT}}{R_{IN}}$$

Input Common Mode Range

The inputs of the current sense amplifier can function from 1.5V below V^+ to 0.5V above it. Not only does this allow a wide V_{SENSE} range, it allows the input reference to be separate from the positive supply (Figure 6).

If the maximum V_{SENSE} is less than $V_{SENSE(MAX)}$ (500mV as shown in the Electrical Characteristics table), the current sense amplifier may monitor its own supply current, as well as that of the load (Figure 7).

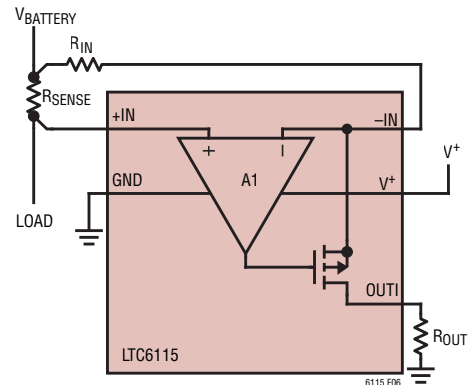

Figure 6. V^+ Powered Separately from Load Supply ($V_{BATTERY}$)

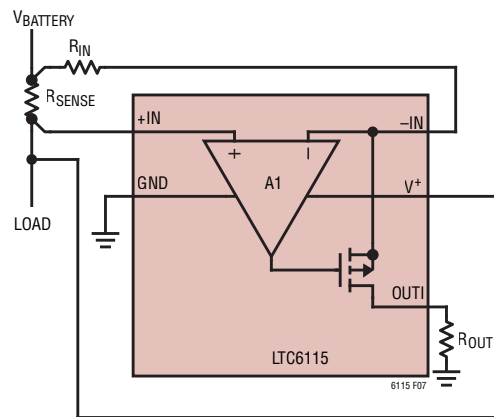

Figure 7. Current Sense Amplifier Supply Current Monitored with Load

Response Time

The current sense amplifier is designed to exhibit fast response to inputs for the purpose of circuit protection or signal transmission. The response time will however also be affected by the external circuit.

If the output current is very low and an input transient occurs, there may be an increased delay before the output voltage begins changing. This can be improved by increasing the minimum output current, either by increasing R_{SENSE} or decreasing R_{IN} . The effect of increased output current is illustrated in the step response curves in the Current Sense Typical Performance Characteristics section of this data sheet. Note that the curves are labeled with respect to the initial output currents.

APPLICATIONS INFORMATION: CURRENT SENSE

If the input changes very quickly, the internal amplifier will slew the gate of the internal output FET (Figure 1) in order to maintain the internal loop. This results in current flowing through R_{IN} and the internal FET. This current slew rate will be determined by the amplifier and FET characteristics as well as the input resistor, R_{IN} . Using a smaller R_{IN} will allow the output current to increase more quickly,

decreasing the response time at the output. This will also have the effect of increasing the maximum output current. Using a larger R_{OUT} will decrease the response time, since $V_{OUT1} = I_{OUT1} \cdot R_{OUT}$. Reducing R_{IN} and increasing R_{OUT} will have the effect of increasing the voltage gain of the circuit.

APPLICATIONS INFORMATION: VOLTAGE SENSE

The voltage sense amplifier provides accurate monitoring of a voltage up to 100V. The input voltage is internally divided down by 40 by a 1M Ω precision resistor divider and the low offset of the amplifier enables accurate buffering of the attenuated voltage. The amplifier can also be put in an appropriate gain in the feedback path to allow full use of the rail-to-rail output of the op amp, when a lower voltage is being monitored on the V_{IN} pin.

The high impedance input resistor divider reduces the leakage concerns associated with large value resistors on a circuit board and the associated measurement errors.

Input Voltage Range

The maximum voltage that can accurately be monitored on the V_{IN} pin is limited by the supply voltage, V_S , as it affects the input common mode of the internal operational amplifier A2. The full 100V range on V_{IN} is available with a supply voltage of 4V or more. With a 3V supply, it is recommended to keep V_{IN} below 60V to maximize precision. Beyond these recommended V_{IN} voltages at each supply voltage, accuracy will degrade.

At lower V_{IN} voltages, external resistors can be used to add gain and maximize use of amplifier A2's rail-to-rail output (see Figure 8).

Preserving Measurement Precision

To maximize precision and make use of the 0.04% typical accuracy of the voltage sense circuit, errors added by the application circuit and the PC board layout should be minimized.

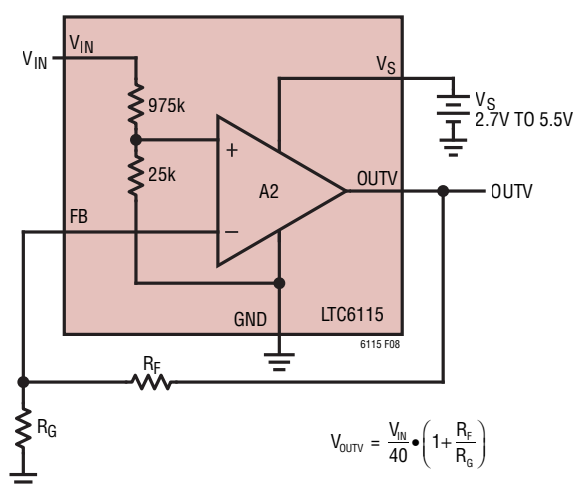

Figure 8. External Resistors to Add Gain

Temperature differentials across the input connections can generate thermocouple voltages of tens of microvolts so the connections to the input leads should be short, close together and away from heat dissipating components. Air current across the board can also generate temperature differentials.

The extremely low input bias current of the LTC6115 voltage sense amplifier FB pin allows accuracy to be maintained with high impedance feedback resistors as well.

Input Clamps

The voltage sense amplifier A2 has anti-parallel diodes between its inputs (Figure 1). The FB pin should not be forced more than a diode voltage away from its expected voltage ($V_{IN}/40$), as this will forward bias a diode and a lot of current will then flow through the pin.

APPLICATIONS INFORMATION: VOLTAGE SENSE

Capacitive Load

The voltage sense amplifier can drive capacitive load up to 100pF in unity gain. The capacitive load driving capability increases as the amplifier is used in higher gain configurations. A small resistance between the output and the load further increases the amount of capacitance the amplifier can drive.

PC Board Layout

Mechanical stress on a PC board and soldering-induced stress can cause offset shifts. A simple way to reduce the stress-related shift is to mount the IC near the short edge of the PC board, or in a corner. The board acts as a stress boundary, or a region where the flexure of the board is minimum. The package should always be mounted so that the leads absorb the stress and not the package. The package is generally aligned with the leads parallel to the long side of the PC board.

Noise Sources

Figure 9 shows all the noise contributors in a typical voltage-sense configuration, with optional gain-setting resistances R_F and R_G .

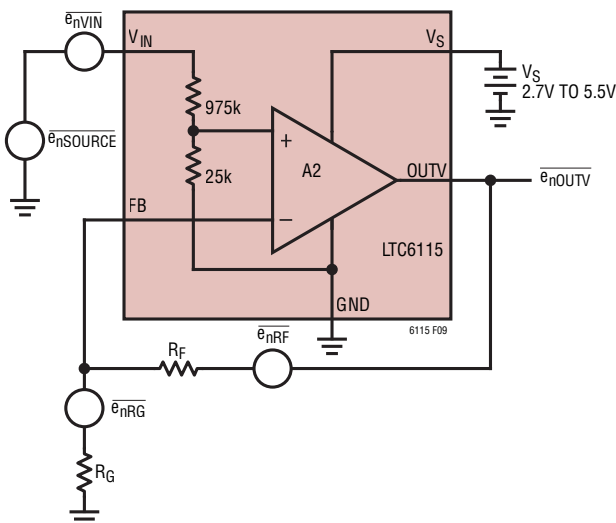

Figure 9. Noise Sources of Voltage Sense Amplifier in LTC6115

The total noise at the output can be calculated with:

$$\overline{e_{n,OUTV}} = \sqrt{\frac{\overline{e_{n,VIN}^2} + \overline{e_{n,SOURCE}^2}}{40^2} \left(1 + \frac{R_F}{R_G}\right)^2 + \overline{e_{n,RG}^2} \frac{R_F^2}{R_G^2} + \overline{e_{n,RF}^2}}$$

The individual sources of noise in this equation, as shown in Figure 9, are:

$\overline{e_{n,VIN}}$ Input-Referred Noise of A2 and 975k to 25k Resistor Divider

$\overline{e_{n,SOURCE}}$ Noise Added by Signal Source

$\overline{e_{n,RF}} = \sqrt{4kTR_F}$ Thermal Noise of R_F

$\overline{e_{n,RG}} = \sqrt{4kTR_G}$ Thermal Noise of R_G

$\overline{e_{n,VIN}}$ accounts for all internal noise sources in A2 (including the 975k to 25k resistor divider and the amplifier), referred back to the V_{IN} input pin. This V_{IN} referred voltage noise density is shown in the typical curve V_{IN} Referred Voltage Noise Spectrum.

When calculating the total output noise, all voltage noise applied at V_{IN} , shown as $\overline{e_{n,SOURCE}}$ in Figure 9, and $\overline{e_{n,VIN}}$ is divided down by 40 due to the 975k to 25k resistor divider. Subsequently this noise is gained up by the non-inverting gain of the amplifier. Conversely, $\overline{e_{n,OUTV}}$, which accounts for all voltage noise at V_{OUT} , is first divided down by the external gain set by R_F and R_G , and then multiplied up by 40 to calculate V_{IN} noise. The plot 0.1Hz to 10Hz Output Voltage Noise (OUTV) depicts peak-to-peak voltage noise at the output, where it has not been referred to the input.

To optimize for lowest output noise, use values no larger than 55k to keep R_F and R_G 's thermal noise comparable to that contributed by the amplifier itself. The trade-off of lower R_F and R_G values is an increase of 10's of μA in power consumption in the feedback network, which may be significant in power-limited designs.

The input current noise density at the feedback pin FB of the voltage sense operational amplifier, A2, is on the order of $1fA/\sqrt{Hz}$. For most practical resistor values, the contribution of input current noise to the total output noise is negligible.

TYPICAL APPLICATIONS

16-Bit Current and Voltage Sensing with LTC6115

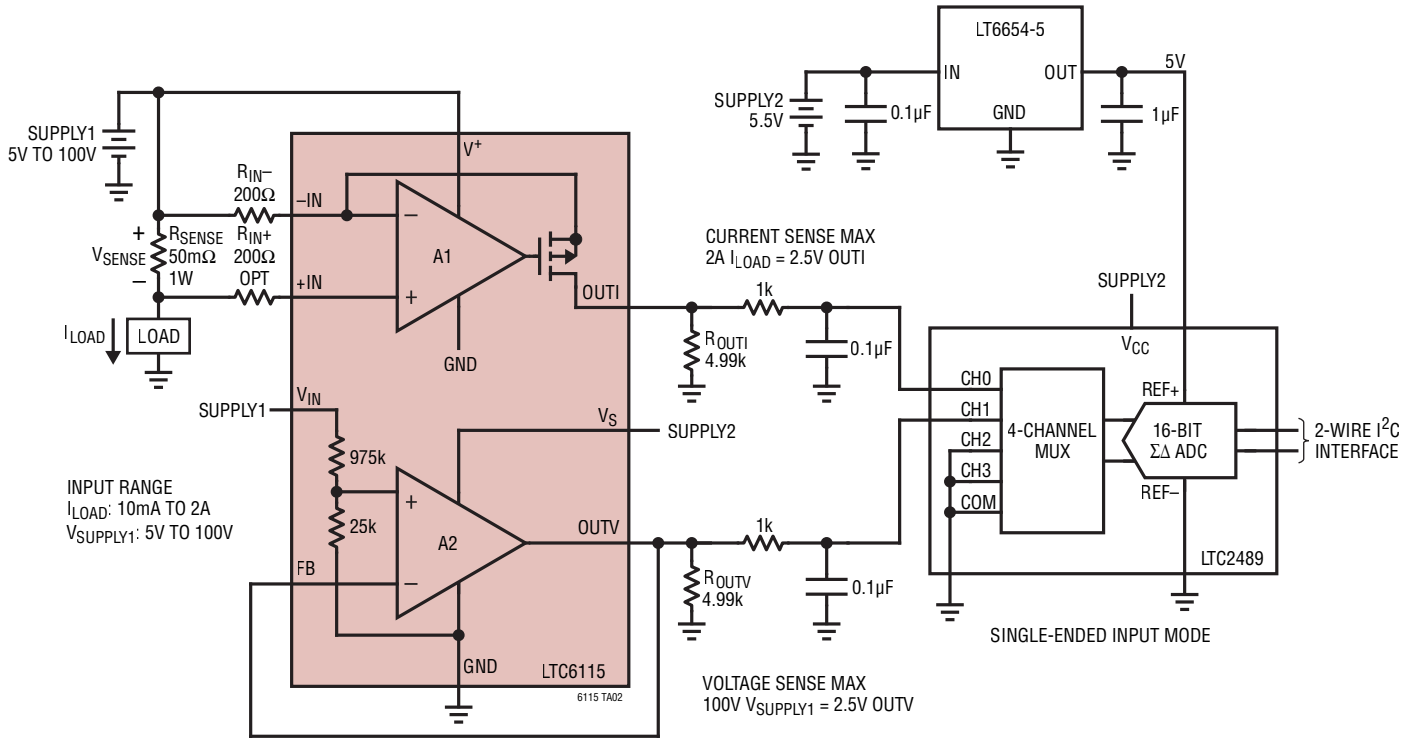

PACKAGE DESCRIPTION

**MS Package
12-Lead Plastic MSOP**

(Reference LTC DWG # 05-08-1668 Rev A)

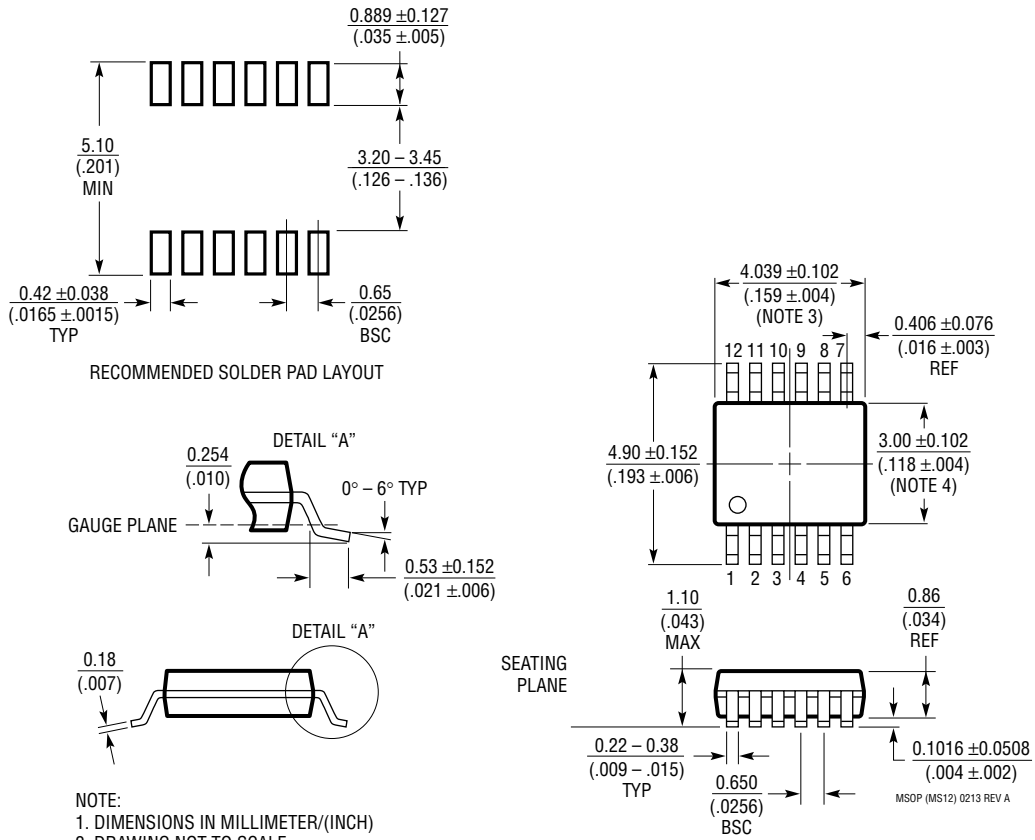

- NOTE:
1. DIMENSIONS IN MILLIMETER/(INCH)
 2. DRAWING NOT TO SCALE
 3. DIMENSION DOES NOT INCLUDE MOLD FLASH, PROTRUSIONS OR GATE BURRS.
MOLD FLASH, PROTRUSIONS OR GATE BURRS SHALL NOT EXCEED 0.152mm (.006") PER SIDE
 4. DIMENSION DOES NOT INCLUDE INTERLEAD FLASH OR PROTRUSIONS.
INTERLEAD FLASH OR PROTRUSIONS SHALL NOT EXCEED 0.152mm (.006") PER SIDE
 5. LEAD COPLANARITY (BOTTOM OF LEADS AFTER FORMING) SHALL BE 0.102mm (.004") MAX

MSOP (MS12) 0213 REV A

REVISION HISTORY

REV	DATE	DESCRIPTION	PAGE NUMBER
A	04/19	Changed Typical Application block diagram.	20
B	11/19	Adding Automotive Qualified Parts to Datasheet	All

TYPICAL APPLICATION

LED Headlamp Supply Monitoring with LTC6115

65W 12.8V LED HEADLAMP MONITOR
 DETECTS IF VOLTAGE EXITS 12V TO 15V RANGE
 AND IF CURRENT EXITS 2.5A TO 6A RANGE

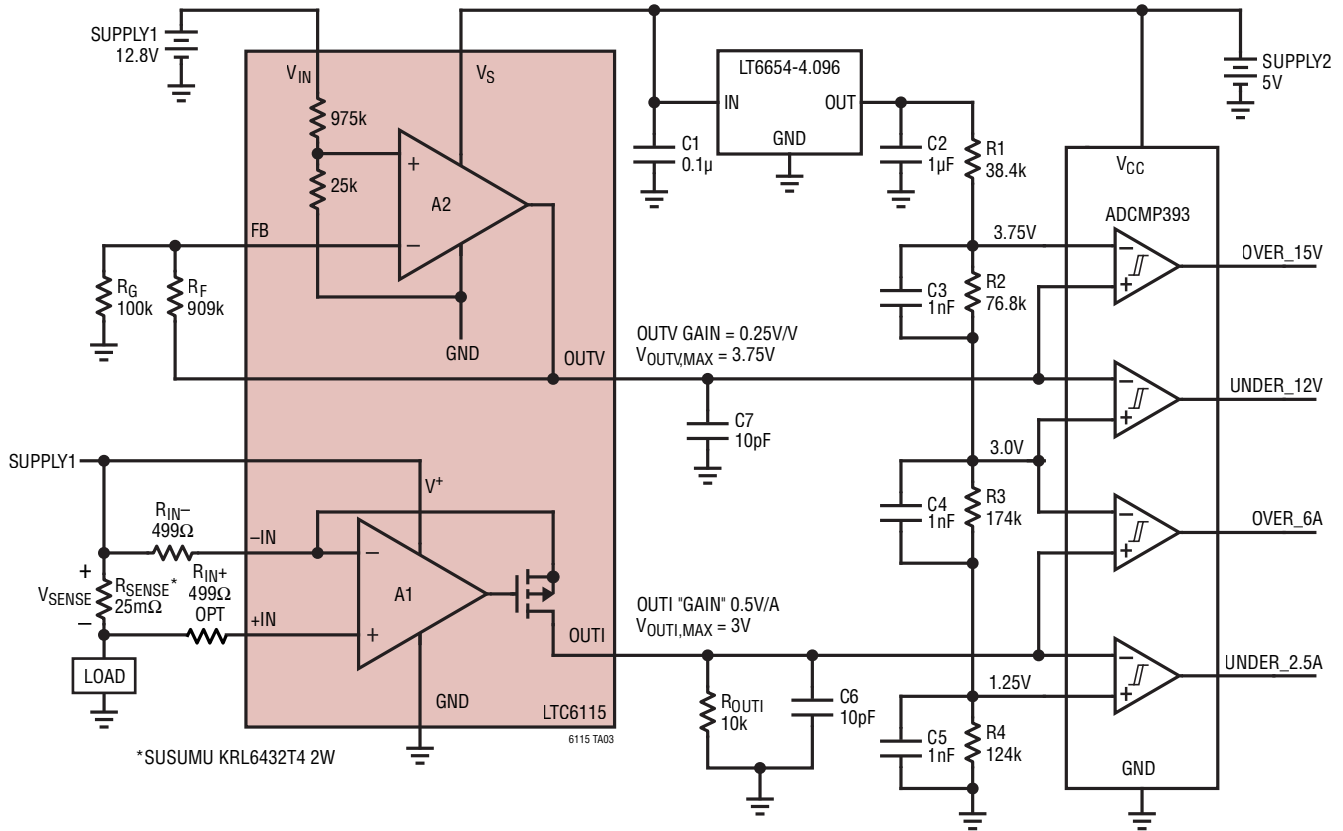

RELATED PARTS

PART NUMBER	DESCRIPTION	COMMENTS
LT[®]1787/LT1787HV	Precision, Bidirectional, High Side Current Sense Amplifier	2.7V to 60V Operation, 75μV Offset, 60μA Current Draw
LTC4150	Coulomb Counter/Battery Gas Gauge	Indicates Charge Quantity and Polarity
LT6100	Gain-Selectable High Side Current Sense Amplifier	4.1V to 48V Operation, Pin-Selectable Gain: 10, 12.5, 20, 25, 40, 50V/V
LTC6101/LTC6101HV	High Voltage High Side Current Sense Amplifier	4V to 60V/5V to 100V Operations, External Resistor Set Gain, SOT23
LTC6102/LTC6102HV	Zero Drift High Side Current Sense Amplifier	4V to 60V, Gain Configurable, 8-Lead MSOP
LTC6103	Dual High Side Precision Current Sense Amplifier	4V to 60V, Gain Configurable, 8-Lead MSOP
LTC6104	Bidirectional High Side Precision Current Sense Amplifier	4V to 60V, Gain Configurable, 8-Lead MSOP
LT6106	Low Cost, High Side Precision Current Sense Amplifier	2.7V to 36V, Gain Configurable, SOT23
ADCMP393	Quad Comparators with Known Power-Up State	2.3V to 5.5V, 26.8μA Supply, 14-Lead TSSOP/SOIC
LTC2489	Easy-Drive 2-/4-Channel ΔΣ	16-Bit, 2.7V to 5.5V Supply, 160μA Conversion 1μA Sleep
LT6654	Precision Wide Supply Low Noise Reference	V _{OUT} +0.5V to 36V, 350μA Supply, ±10mA Source and Sink

Looking for pricing, stock, or lifecycle information?

Click below to explore more details on WIN SOURCE:

 [View LTC6115IMS#PBF on WIN SOURCE](#)

 [Analog Devices Inc. Information](#)

Optimize Your Supply Chain with WIN SOURCE Solutions

-  Global Sourcing Solution
-  Obsolete Management
-  Cost Control Management
-  Shortage Management
-  Alternative Solution
-  Excess Inventory Management