



**THE DATASHEET OF
UPD70F3378M2GJA-GAE-AX**





Data Sheet

V850ES/FE3

32-bit Single-Chip Microcontroller

Hardware

μPD70F3370A(A)	μPD70F3371(A)
μPD70F3370A(A1)	μPD70F3371(A1)
μPD70F3370A(A2)	μPD70F3371(A2)

Notes for CMOS Devices

1. Precaution against ESD for semiconductors

Strong electric field, when exposed to a MOS device, can cause destruction of the gate oxide and ultimately degrade the device operation. Steps must be taken to stop generation of static electricity as much as possible, and quickly dissipate it once, when it has occurred. Environmental control must be adequate. When it is dry, humidifier should be used. It is recommended to avoid using insulators that easily build static electricity. Semiconductor devices must be stored and transported in an anti-static container, static shielding bag or conductive material. All test and measurement tools including work bench and floor should be grounded. The operator should be grounded using wrist strap. Semiconductor devices must not be touched with bare hands. Similar precautions need to be taken for PW boards with semiconductor devices on it.

2. Handling of unused input pins for CMOS

No connection for CMOS device inputs can be cause of malfunction. If no connection is provided to the input pins, it is possible that an internal input level may be generated due to noise, etc., hence causing malfunction. CMOS devices behave differently than Bipolar or NMOS devices. Input levels of CMOS devices must be fixed high or low by using a pull-up or pull-down circuitry. Each unused pin should be connected to VDD or GND with a resistor, if it is considered to have a possibility of being an output pin. All handling related to the unused pins must be judged device by device and related specifications governing the devices.

3. Status before initialization of MOS devices

Power-on does not necessarily define initial status of MOS device. Production process of MOS does not define the initial operation status of the device. Immediately after the power source is turned ON, the devices with reset function have not yet been initialized. Hence, power-on does not guarantee out-pin levels, I/O settings or contents of registers. Device is not initialized until the reset signal is received. Reset operation must be executed immediately after power-on for devices having reset function.

Legal Notes

- The information in this document is current as of January 2007. The information is subject to change without notice. For actual design-in, refer to the latest publications of NEC Electronics data sheets or data books, etc., for the most up-to-date specifications of NEC Electronics products. Not all products and/or types are available in every country. Please check with an NEC sales representative for availability and additional information.
- No part of this document may be copied or reproduced in any form or by any means without prior written consent of NEC Electronics. NEC Electronics assumes no responsibility for any errors that may appear in this document.
- NEC Electronics does not assume any liability for infringement of patents, copyrights or other intellectual property rights of third parties by or arising from the use of NEC Electronics products listed in this document or any other liability arising from the use of such NEC Electronics products. No license, express, implied or otherwise, is granted under any patents, copyrights or other intellectual property rights of NEC Electronics or others.
- Descriptions of circuits, software and other related information in this document are provided for illustrative purposes in semiconductor product operation and application examples. The incorporation of these circuits, software and information in the design of customer's equipment shall be done under the full responsibility of customer. NEC Electronics assumes no responsibility for any losses incurred by customers or third parties arising from the use of these circuits, software and information.
- While NEC Electronics endeavors to enhance the quality, reliability and safety of NEC Electronics products, customers agree and acknowledge that the possibility of defects thereof cannot be eliminated entirely. To minimize risks of damage to property or injury (including death) to persons arising from defects in NEC Electronics products, customers must incorporate sufficient safety measures in their design, such as redundancy, fire-containment and anti-failure features.
- NEC Electronics products are classified into the following three quality grades: "Standard", "Special" and "Specific".

The "Specific" quality grade applies only to NEC Electronics products developed based on a customer-designated "quality assurance program" for a specific application. The recommended applications of NEC Electronics product depend on its quality grade, as indicated below. Customers must check the quality grade of each NEC Electronics product before using it in a particular application.

- "Standard": Computers, office equipment, communications equipment, test and measurement equipment, audio and visual equipment, home electronic appliances, machine tools, personal electronic equipment and industrial robots.
- "Special": Transportation equipment (automobiles, trains, ships, etc.), traffic control systems, anti-disaster systems, anti-crime systems, safety equipment and medical equipment (not specifically designed for life support).
- "Specific": Aircraft, aerospace equipment, submersible repeaters, nuclear reactor control systems, life support systems and medical equipment for life support, etc.

The quality grade of NEC Electronics products is "Standard" unless otherwise expressly specified in NEC Electronics data sheets or data books, etc. If customers wish to use NEC Electronics products in applications not intended by NEC Electronics, they must contact NEC Electronics sales representative in advance to determine NEC Electronics 's willingness to support a given application.

- Notes:**
1. "NEC Electronics" as used in this statement means NEC Electronics Corporation and also includes its majority-owned subsidiaries.
 2. "NEC Electronics products" means any product developed or manufactured by or for NEC Electronics (as defined above).
 3. SuperFlash[®] is a registered trademark of Silicon Storage Technology, Inc. in several countries including the United States and Japan. This product uses SuperFlash[®] technology licensed from Silicon Storage Technology, Inc.

Regional Information

Some information contained in this document may vary from country to country. Before using any NEC product in your application, please contact the NEC office in your country to obtain a list of authorized representatives and distributors. They will verify:

- Device availability
- Ordering information
- Product release schedule
- Availability of related technical literature
- Development environment specifications (for example, specifications for third-party tools and components, host computers, power plugs, AC supply voltages, and so forth)
- Network requirements

In addition, trademarks, registered trademarks, export restrictions, and other legal issues may also vary from country to country.

*For further information,
please contact:*

NEC Electronics Corporation
1753, Shimonumabe, Nakahara-ku,
Kawasaki, Kanagawa 211-8668,
Japan
Tel: 044-435-5111
<http://www.necel.com/>

[America]

NEC Electronics America, Inc.
2880 Scott Blvd.
Santa Clara, CA 95050-2554, U.S.A.
Tel: 408-588-6000
800-366-9782
<http://www.am.necel.com/>

[Europe]

NEC Electronics (Europe) GmbH
Arcadiastrasse 10
40472 Düsseldorf, Germany
Tel: 0211-65030
<http://www.eu.necel.com/>

Hanover Office
Podbielski Strasse 166 B
30177 Hanover
Tel: 0 511 33 40 2-0

Munich Office
Werner-Eckert-Strasse 9
81829 München
Tel: 0 89 92 10 03-0

Stuttgart Office
Industriestrasse 3
70565 Stuttgart
Tel: 0 711 99 01 0-0

United Kingdom Branch
Cygnus House, Sunrise Parkway
Linford Wood, Milton Keynes
MK14 6NP, U.K.
Tel: 01908-691-133

Succursale Française
9, rue Paul Dautier, B.P. 52180
78142 Velizy-Villacoublay Cédex
France
Tel: 01-3067-5800

Sucursal en España
Juan Esplandiú, 15
28007 Madrid, Spain
Tel: 091-504-2787

Tyskland Filial
Täby Centrum
Entrance S (7th floor)
18322 Täby, Sweden
Tel: 08 638 72 00

Filiale Italiana
Via Fabio Filzi, 25/A
20124 Milano, Italy
Tel: 02-667541

Branch The Netherlands
Steijgerweg 6
5616 HS Eindhoven
The Netherlands
Tel: 040 265 40 10

[Asia & Oceania]

NEC Electronics (China) Co., Ltd
7th Floor, Quantum Plaza, No. 27 ZhiChunLu Haidian
District, Beijing 100083, P.R.China
TEL: 010-8235-1155
<http://www.cn.necel.com/>

NEC Electronics Shanghai Ltd.
Room 2509-2510, Bank of China Tower,
200 Yincheng Road Central,
Pudong New Area, Shanghai P.R. China P.C:200120
Tel: 021-5888-5400
<http://www.cn.necel.com/>

NEC Electronics Hong Kong Ltd.
12/F., Cityplaza 4,
12 Taikoo Wan Road, Hong Kong
Tel: 2886-9318
<http://www.hk.necel.com/>

Seoul Branch
11F., Samik Lavied'or Bldg., 720-2,
Yeoksam-Dong, Kangnam-Ku,
Seoul, 135-080, Korea
Tel: 02-558-3737

NEC Electronics Taiwan Ltd.
7F, No. 363 Fu Shing North Road
Taipei, Taiwan, R. O. C.
Tel: 02-8175-9600

NEC Electronics Singapore Pte. Ltd.
238A Thomson Road,
#12-08 Novena Square,
Singapore 307684
Tel: 6253-8311
<http://www.sg.necel.com/>

G06.6-1A

Table of Contents

1.	Pin Group Information	9
1.1	Device package information	9
1.2	Pin Groups 1x: Pins supplied by EVDD	9
1.3	Pin Groups 2x: Pins supplied by EVDD	9
1.4	Pin Groups 3x: Pins supplied by BVDD	10
1.5	Pin Groups 4: Pins supplied by AVREF0	10
1.6	Pin Groups 5: Pins supplied by AVREF1	10
1.7	Pin Groups 6: Pins supplied by EVDD	10
1.8	Pin Groups 7: Pins supplied by VRO	10
2.	Electrical Specifications of (A)-Grade	11
2.1	Absolute Maximum Ratings	11
2.2	Capacities	11
2.3	Operating condition	12
2.4	Voltage Regulator Characteristics	13
2.5	Clock Generator Circuit	13
2.5.1	Main System Clock Oscillation Circuit Characteristics	13
2.5.2	Sub System Clock Oscillation Circuit Characteristics	14
2.5.3	Internal-OSC Characteristics	14
2.5.4	PLL Characteristics	15
2.5.5	SSCG Characteristics	15
2.6	DC Characteristics	16
2.6.1	Input/Output Level	16
2.6.2	PIN leakage current	17
2.6.3	Power supply current (A-grade)	18
2.6.3.1	FE3 128KB mPD70F3370A, FE3 256KB mPD70F3371	18
2.7	AC Characteristics	21
2.7.1	CLKOUT Output Timing	21
2.7.2	RESET, Interrupt, ADTRG Timing	22
2.7.3	Key Return Timing	22
2.7.4	Timer Timing	22
2.7.5	CSI Timing	23
2.7.6	UART Timing	23
2.7.7	IIC Timing	24
2.7.8	CAN Timing	26
2.8	A/D Converter	27
2.9	POC	28
2.10	LVI	29
2.11	RAM Retention Flag	29
2.12	Data Retention Characteristics	30
2.13	Flash Memory Programming Characteristics	31
3.	Electrical Specifications of (A1)-Grade	32
3.1	Absolute Maximum Ratings	32
3.2	Capacities	32
3.3	Operating condition	32
3.4	Voltage Regulator Characteristics	32
3.5	Clock Generator Circuit	32
3.5.1	Main System Clock Oscillation Circuit Characteristics	32
3.5.2	Sub System Clock Oscillation Circuit Characteristics	33
3.5.3	Internal-OSC Characteristics	33
3.5.4	PLL Characteristics	33
3.5.5	SSCG Characteristics	33

Table of Contents

3.6	DC Characteristics	34
3.6.1	Input/Output Level	34
3.6.2	PIN leakage current	35
3.6.3	Power supply current (A1-grade)	36
3.6.3.1	FE3 128KB mPD70F3370A, FE3 256KB mPD70F3371	36
3.7	AC Characteristics	39
3.7.1	CLKOUT Output Timing	39
3.7.2	RESET, Interrupt, ADTRG Timing	39
3.7.3	Key Return Timing	39
3.7.4	Timer Timing	39
3.7.5	CSI Timing	39
3.7.6	UART Timing	39
3.7.7	IIC Timing	39
3.7.8	CAN Timing	39
3.8	A/D Converter	40
3.9	POC	40
3.10	LVI	40
3.11	RAM Retention Flag	40
3.12	Data Retention Characteristics	40
3.13	Flash Memory Programming Characteristics	40
4.	Electrical Specifications of (A2)-Grade	41
4.1	Absolute Maximum Ratings	41
4.2	Capacities	41
4.3	Operating condition	42
4.4	Voltage Regulator Characteristics	42
4.5	Clock Generator Circuit	42
4.5.1	Main System Clock Oscillation Circuit Characteristics	42
4.5.2	Sub System Clock Oscillation Circuit Characteristics	43
4.5.3	Internal-OSC Characteristics	43
4.5.4	PLL Characteristics	43
4.5.5	SSCG Characteristics	43
4.6	DC Characteristics	44
4.6.1	Input/Output Level	44
4.6.2	PIN leakage current	44
4.6.3	Power supply current (A2-grade)	45
4.6.3.1	FE3 128KB mPD70F3370A, FE3 256KB mPD70F3371	45
4.7	AC Characteristics	48
4.7.1	CLKOUT Output Timing	48
4.7.2	RESET, Interrupt, ADTRG Timing	48
4.7.3	Key Return Timing	48
4.7.4	Timer Timing	48
4.7.5	CSI Timing	48
4.7.6	UART Timing	48
4.7.7	IIC Timing	48
4.7.8	CAN Timing	48
4.8	A/D Converter	49
4.9	POC	49
4.10	LVI	49
4.11	RAM Retention Flag	49
4.12	Data Retention Characteristics	49
4.13	Flash Memory Programming Characteristics	50

Table of Contents

5.	Package	51
5.1	Package Dimension	51
5.2	Product Marking	52
5.2.1	Marking of pin 1 at a QFP (Quad Flat Package)	52
5.2.2	Identification of Lead-Free Products	53
6.	Change History	54

1. Pin Group Information

1.1 Device package information

The V850ES/Fx3 device series comprises several members. An overview with the pin and package information is given in the following table:

Series Member	# Pins	Device package information
μPD70F3370A μPD70F3371	64	FE3
μPD70F3372 μPD70F3373	80	FF3
μPD70F3374 μPD70F3375 μPD70F3376A μPD70F3377A	100	FG3
μPD70F3378 μPD70F3379 μPD70F3380 μPD70F3381 μPD70F3382	144	FJ3
μPD70F3383 μPD70F3384 μPD70F3385	176	FK3

This document describes the specification for the V850ES/FE3.

1.2 Pin Groups 1x: Pins supplied by EVDD

1B: (SHMT1)

- P04, P30-31, P34; P40, P91, P913-915 (FE3)
- P04, P30-31, P34; P38-39, P40, P91, P913-915 (FF3)
- P04, P30-31, P34; P36-39, P40, P91, P911, P913-915 (FG3)
- P04, P30-31, P34; P36-39, P40, P63-69, P614-615, P80-81, P91, P911, P913-915 (FJ3)
- P04, P30-31, P34; P36-39, P40, P63-69, P614-615, P80-81, P91, P911, P913-915, P156-157 (FK3)

1D: (SHMT3)

- P00-03, P05-P06, P32-33, P35, P41-42, P50-55, P90, P96-99 (FE3)
- P00-03, P05-P06, P32-33, P35, P41-42, P50-55, P90, P96-99 (FF3)
- P00-03, P05-P06, P10-11, P32-33, P35, P41-42, P50-55, P90, P92-910, P912 (FG3)
- P00-03, P05-P06, P10-11, P32-33, P35, P41-42, P50-55, P60-62, P610-613, P90, P92-910, P912 (FJ3)
- P00-03, P05-P06, P10-11, P32-33, P35, P41-42, P50-55, P60-62, P610-613, P90, P92-910, P912, P150-155 (FK3)

1.3 Pin Groups 2x: Pins supplied by EVDD

2A: (CMOS)

- PCM0-1 (FE3)
- PCM0-3, PCS0-1, PCT0-1, PCT4, PCT6 (FF3)

2D: (SHMT3)

- PDL0-7 (FE3)
- PDL0-11 (FF3)

1.4 Pin Groups 3x: Pins supplied by BVDD

3A: (CMOS)

- PCM0-3, PCS0-1, PCT0-1, PCT4, PCT6 (FG3)
- PCD0-3, PCM0-5, PCS0-7, PCT0-7 (FJ3 + FK3)

3D: (SHMT3)

- PDL0-13 (FG3)
- PDL0-15 (FJ3 + FK3)

1.5 Pin Groups 4: Pins supplied by AVREF0

4: (CMOS)

- P70-79 (FE3)
- P70-711 (FF3)
- P70-715 (FG3)
- P70-715, P120-127 (FJ3 + FK3)

1.6 Pin Groups 5: Pins supplied by AVREF1

- P20-P215 (FK3) (CMOS)

1.7 Pin Groups 6: Pins supplied by EVDD

- RESET (SHMT2)
- IC, FLMD0

1.8 Pin Groups 7: Pins supplied by VRO

- X1, X2, XT1, XT2

2. Electrical Specifications of (A)-Grade

This product has to be used only under the conditions of VDD=EVDD. Operation is not ensured at the time of using this product except this condition.

2.1 Absolute Maximum Ratings

Absolute Maximum Ratings (Ta=25°C)

Parameter	Symbol	Conditions	Rating	Unit	
Supply voltage	VDD	VDD=EVDD,	-0.5 to +6.5	V	
	EVDD	VDD=EVDD	-0.5 to +6.5	V	
	AVREF0		-0.5 to +6.5	V	
	VSS	VSS=EVSS=AVSS	-0.5 to +0.5	V	
	EVSS	VSS=EVSS=AVSS	-0.5 to +0.5	V	
	AVSS	VSS=EVSS=AVSS	-0.5 to +0.5	V	
Input voltage	VI1	Pin Group 1x, 2x, 6	-0.5 to EVDD+0.5 <small>Note1</small>	V	
	VI3	Pin Group 7	-0.5 to VRO+0.5 <small>Note1</small>	V	
Analog input voltage	VIAN	Pin Group 4	-0.5 to AVREF0+0.5 <small>Note1</small>	V	
High level output current	IOH	Pin Group 1x, 2x	1 pin	-4	mA
			Total	-50	mA
		Pin Group 4	1 pin	-4	mA
			Total	-20 <small>Note2</small>	mA
Low level output current	IOL	Pin Group 1x, 2x	1 pin	4	mA
			Total	50	mA
		Pin Group 4	1 pin	4	mA
			Total	20 <small>Note2</small>	mA
Operating ambient temperature	Ta	Normal operating mode	-40 to +85	°C	
		Flash programming mode	-40 to +85		
Storage temperature	Tstg		-40 to +125	°C	

Remarks: 1. The characteristics of the dual-function pins are the same as those of the port pins unless otherwise specified

Notes: 1. Be sure not to exceed the absolute maximum ratings (Max. value) of each supply voltage.
2. Excluding ADC IAREF0 current.

2.2 Capacities

(Ta = 25°C, VDD = EVDD = AVREF0 = VSS = EVSS = AVSS = 0V)

Parameter	Symbol	Conditions	MIN.	TYP.	MAX.	Unit
Input/output capacitance	CIO	f=1MHz, Not measured pins is 0V.			10	pF

2.3 Operating condition

(Ta = -40 to +85°C, C=4.7uF, VDD = EVDD = 3.3 to 5.5V, AVREF0 = 3.3 to 5.5V, VSS = EVSS = AVSS = 0V)

Internal System clock frequency (f _{VBLK})	Supply voltage	Operating Condition
4.0 ≤ f _{xx} ≤ 32MHz Note1	4.0V ≤ VDD ≤ 5.5V ^{Note2}	Operation of functions is usable under following conditions: <ul style="list-style-type: none"> Peripheral clock frequency <ul style="list-style-type: none"> f_{XP1} ≤ 32MHz f_{XP2} ≤ 32MHz AC characteristics: <ul style="list-style-type: none"> Refer to chapter '2.7 AC Characteristics' for details.
	3.5V ≤ VDD < 4.0V ^{Note2}	Operation of functions is usable under following conditions: <ul style="list-style-type: none"> Peripheral clock frequency <ul style="list-style-type: none"> f_{XP1} ≤ 20MHz f_{XP2} ≤ 20MHz AC characteristics: <ul style="list-style-type: none"> Refer to chapter '2.7 AC Characteristics' for details.
	3.3V ≤ VDD < 3.5V ^{Note2}	Only operation of the following functions is assured: <ul style="list-style-type: none"> CPU Flash (include programming) RAM IO Buffer Port WT WDT INT CLM POC LVI
	3.3V ≤ AVREF0 ≤ 5.5V	<ul style="list-style-type: none"> A/D Converter <ul style="list-style-type: none"> Refer to chapter '2.8 A/D Converter' for details. stop ADC for AVREF0 < 4.0V (ADA0CE bit =0)
32kHz ≤ f _{XT} ≤ 35kHz (Crystal)	3.3V ≤ VDD < 5.5V ^{Note2}	-
12.5kHz ≤ f _{XT} ≤ 27.5kHz ^{Note3} (RC)		-
f _{RL} (240kHz Internal-OSC)		-

- Notes:**
- For using SSCG please refer to '2.5.5 SSCG Characteristics' for details
 - VDD = EVDD
 - RC Oscillation frequency is min. 25kHz max. 55kHz. This clock is divided by 2 internally.

2.4 Voltage Regulator Characteristics

(Ta = -40 to +85°C, C=4.7uF, VDD = EVDD, VSS = EVSS = AVSS = 0V)

Parameter	Symbol	Conditions	MIN.	TYP.	MAX.	Unit
Input voltage	VDD		3.5		5.5	V
		Limited function see '2.3 Operating condition'	3.3			V
Output voltage	VRO			2.5		V
Output voltage stabilization time	t _{REG} ^{Note}	After VDD reaches voltage range min. 3.3V To connect C=4.7uF on REGC terminal			1	ms

Note: In case of non-POC device, be sure to start VDD in the state of $\overline{\text{RESET}}=\text{VSS}=0\text{V}$.
For POC devices there is no need to control external $\overline{\text{RESET}}$ terminal. For decives with POC function the internal $\overline{\text{RESET}}$ signal will automatically controlled until VRO is stable.

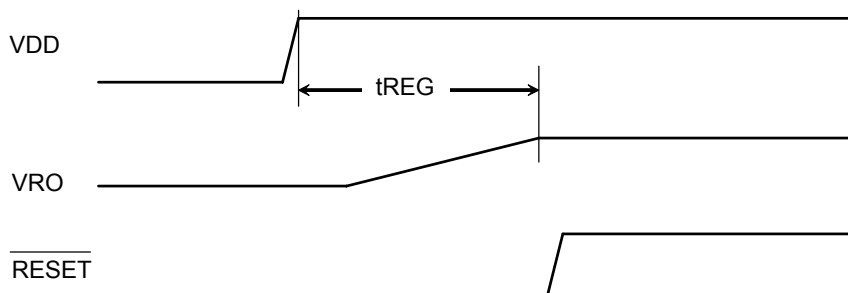

2.5 Clock Generator Circuit

2.5.1 Main System Clock Oscillation Circuit Characteristics

(Ta = -40 to +85°C, C=4.7uF, VDD = EVDD = 3.3 to 5.5V, AVREF0 = 3.3 to 5.5V, VSS = EVSS = AVSS = 0V)

Resonator	Recommended Circuit	Parameter	Conditions	MIN.	TYP.	MAX.	Unit
Crystal / Ceramic resonator	Refer to figure below	Oscillator frequency (fx) ^{Note1}		4		16	MHz
		Oscillation stabilization time ^{Note2}	After STOP mode	64 ^{Note4}	Note3		μs
			After IDLE2 mode	54 ^{Note4}	Note3		μs

- Notes:**
1. Indicates only oscillation circuit characteristics. Refer to '2.7 AC Characteristics' for CPU operation clock.
 2. Time required to stabilize oscillation after VDD reaches oscillator voltage range MIN. 3.3V
 3. Depends on the setting of the oscillation stabilization time select register (OSTS)
 4. Minimum time required to stabilize flash. Time has to be secured by setting the oscillation stabilization time select register (OSTS)

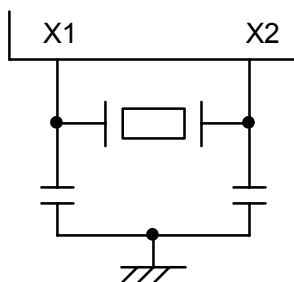

2.5.2 Sub System Clock Oscillation Circuit Characteristics

(Ta = -40 to +85°C, C=4.7uF, VDD = EVDD = 3.3 to 5.5V, AVREF0 = 3.3 to 5.5V, VSS = EVSS = AVSS = 0V)

Resonator	Recommended Circuit	Parameter	Conditions	MIN.	TYP.	MAX.	Unit
Crystal resonator	Refer to Figure 1	Oscillator frequency (fxt) ^{Note1}		32	32.768	35	kHz
		Oscillation stabilization time ^{Note2}				10	s
RC resonator	Refer to Figure 2	Oscillator frequency ^{Note1,4}	R=390KΩ±5% ^{Note3} , C=47pF±10% ^{Note3}	25	40	55	kHz
		Oscillation stabilization time ^{Note2}				100	μs

- Notes:**
1. Indicates only oscillation circuit characteristics. Refer to "AC Characteristic" for cpu operation clock.
 2. Time required to stabilize oscillation after VDD reaches oscillator voltage range min. 3.3V
 3. In order to avoid the influence of wiring capacity, shorten wiring as much as possible.
 4. RC Oscillation frequency is typ. 40kHz. This clock is divided by 2 internally. In case of RC Oscillator, internal system clock frequency (fxt) is min. 12.5kHz, typ. 20kHz, max. 27.5kHz.



2.5.3 Internal-OSC Characteristics

(Ta = -40 to +85°C, C=4.7uF, VDD = EVDD = 3.3 to 5.5V, AVREF0 = 3.3 to 5.5V, VSS = EVSS = AVSS = 0V)

Parameter	Symbol	Conditions	MIN.	TYP.	MAX.	Unit
Output frequency	f _{RL}	240kHz Internal-OSC	204	240	276	kHz
	f _{RH}	8MHz Internal-OSC	7.2	8.0	8.8	MHz
Oscillation stabilization time		240kHz Internal-OSC		10	36	μs
		8MHz Internal-OSC	51	92	256	μs

2.5.4 PLL Characteristics

(Ta = -40 to +85°C, C=4.7uF, VDD = EVDD = 3.3 to 5.5V, AVREF0 = 3.3 to 5.5V, VSS = EVSS = AVSS = 0V)

Parameter	Symbol	Conditions	MIN.	TYP.	MAX.	Unit
Input frequency	fx		4		16	MHz
	f _{PLLI}	Note1	3		6	MHz
Output frequency	fx _x	≤256KB product	12		32	MHz
Lock time	t _{PLL}	After VDD reaches voltage range min. 3.3V			800	μs
Output period jitter Note2	tpj	Peak to peak			2.0	ns

- Notes:** 1. The input of the PLL (f_{PLLI}) can be set to f_x, f_x/2, or f_x/4. The divider is set through an option byte in the code flash memory.
 2. Not tested in production.

2.5.5 SSCG Characteristics

(Ta = -40 to +85°C, C=4.7uF, VDD = EVDD = 3.3 to 5.5V, AVREF0 = 3.3 to 5.5V, VSS = EVSS = AVSS = 0V)

Parameter	Symbol	Conditions	MIN.	TYP.	MAX.	Unit
Input frequency	fx		4		16	MHz
Output frequency	f _{xx}	≤256KB product	12		32	MHz
Lock time	t _{SSCG}	After VDD reaches voltage range min. 3.3V			1000	μs

Remark: The SSCG MAX output frequency indicates the case without modulation. If modulation is enabled the average SSCG frequency has to be set lower. The maximum achievable average operating frequency with modulation is as follows:

SSCG input clock divider selector SFC1[6:4]	Percent modulation		Maximum average operating frequency		Unit
	TYP	MAX	≤256KB product		
000B	± 0.5%	± 2.0%	31.4		MHz
001B	± 1.0%	± 2.5%	31.2		
010B	± 2.0%	± 4.0%	30.7		
011B	± 3.0%	± 6.0%	30.1		
100B	± 4.0%	± 8.0%	29.4		
101B	± 5.0%	± 10.0%	28.8		

2.6 DC Characteristics

2.6.1 Input/Output Level

(Ta = -40 to +85°C, C=4.7uF, VDD = EVDD = 3.3 to 5.5V, AVREF0 = 3.3 to 5.5V, VSS = EVSS = AVSS = 0V)

Parameter	Sym- bol	Conditions	MIN.	TYP.	MAX.	Unit	
High level input voltage	VIH1	Pin Group 1B	0.7·EVDD		EVDD	V	
	VIH2	Pin Group 1D	0.8·EVDD		EVDD	V	
		Pin Group 2D	0.8·EVDD		EVDD	V	
	VIH3	Pin Group 2A	0.7·EVDD		EVDD	V	
	VIH4	Pin Group 4	0.7·AVREF0		AVREF0	V	
VIH5	Pin Group 6	0.8·EVDD		EVDD	V		
Low level input voltage	VIL1	Pin Group 1B	EVSS		0.3·EVDD	V	
	VIL2	Pin Group 1D	EVSS		0.4·EVDD	V	
		Pin Group 2D	EVSS		0.4·EVDD	V	
	VIL3	Pin Group 2A	EVSS		0.3·EVDD	V	
	VIL4	Pin Group 4	AVSS		0.3·AVREF0	V	
VIL5	Pin Group 6	EVSS		0.2·EVDD	V		
Input hysteresis	VHYS1	Pin Group 1B	Center point at 0.5 x EVDD ^{Note3}		0.267 x EVDD - 0.51V	V	
	VHYS2	Pin Group 1D	Center point at 0.6 x EVDD ^{Note3}		0.192 x EVDD - 0.31V	V	
		Pin Group 2D	Center point at 0.6 x EVDD ^{Note3}		0.192 x EVDD - 0.31V	V	
	VHYS5	Pin Group 6	Center point at 0.5 x EVDD ^{Note3}		0.535 x EVDD - 0.9V	V	
High level output voltage ^{Note2}	VOH1	Pin Group 1x, 2x	IOH=-1.0mA	EVDD-1.0		EVDD	V
			IOH=-100uA	EVDD-0.5		EVDD	V
	VOH3	Pin Group 4	IOH=-1.0mA	AVREF0-1.0		AVREF0	V
			IOH=-100uA	AVREF0-0.5		AVREF0	V
Low level output voltage ^{Note2}	VOL1	Pin Group 1x, 2x	IOL=1.0mA	0		0.4	V
		P914, 915	IOL=3.0mA				
	VOL3	Pin Group 4	IOL=1.0mA	0		0.4	V
Software pull-up resistor	R1	VI=0V	10	30	100	kΩ	
Software ^{Note1} pull-down resistor	R2	VI=VDD	10	30	100	kΩ	

Remark: The characteristics of the dual-function pins are the same as those of the port pins unless otherwise specified.

- Notes:**
1. $\overline{\text{DRST}}$ terminal only. (Control register is OCDM)
 2. Total IOH/IOL max is 20mA/-20mA each power supply line (EVDD and AVREF0). AVREF0 IOH/IOL current is excluding ADC0 current IAREF0.
 3. Typical value. Not tested and guaranteed

2.6.2 PIN leakage current

(Ta = -40 to +85°C, C=4.7uF, VDD = EVDD = 3.3 to 5.5V, AVREF0 = 3.3 to 5.5V, VSS = EVSS = AVSS = 0V)

Parameter	Symbol	Conditions	MIN.	TYP.	MAX.	Unit
High level input leakage current	ILIH1	VI=VDD	Analog pins		0.2	uA
			Other pins ^{Note1}		0.5	
Low level input leakage current	ILIL1	VI=0V	Analog pins		-0.2	
			Other pins ^{Note1}		-0.5	
High level output leakage current	ILOH1	VO=VDD	Analog pins		0.2	
			Other pins		0.5	
Low level output leakage current	ILOL1	VO=0V	Analog pins		-0.2	
			Other pins		-0.5	

Notes: 1. The input leakage current of FLMD0 is as follows:
 High level input leakage current : 2.0uA
 Low level input leakage current : -2.0uA

2.6.3 Power supply current (A-grade)

2.6.3.1 FE3 128KB μ PD70F3370A, FE3 256KB μ PD70F3371

(a) Absolute values

(Ta = -40 to +85°C, C=4.7 μ F,

VDD = EVDD = 3.3 to 5.5V, AVREF0 = 3.3 to 5.5V, VSS = EVSS = AVSS = 0V^{Note1)})

Mode	Symbol	Condition				TYP.	MAX.	Unit
Operating mode Note2,8	IDD1	All peripherals running	Peripheral: f _{xx} PRSI option: 0	PLL: ON 12MHz ≤ f _{xx} ≤ 32MHz	f _{xx} =20MHz f _x =5MHz	27	37	mA
					f _{xx} =32MHz f _x =16MHz	39	51	mA
			PLL: OFF 4MHz ≤ f _{xx} ≤ 16MHz	f _{xx} =8MHz 8MHz Internal-OSC ^{Note3}	13	20	mA	
				f _{xx} =16MHz f _x =16MHz	21	30	mA	
		Peripheral: f _{xx} /2 PRSI option: 1	PLL: ON 12MHz ≤ f _{xx} ≤ 32MHz	f _{xx} =32MHz f _x =16MHz	35	47	mA	
			All peripherals stopped	Peripheral: f _{xx} PRSI option: 0	PLL: ON 12MHz ≤ f _{xx} ≤ 32MHz	f _{xx} =20MHz f _x =5MHz	22	
					f _{xx} =32MHz f _x =16MHz	32		mA
		PLL: OFF 4MHz ≤ f _{xx} ≤ 16MHz		f _{xx} =8MHz 8MHz Internal-OSC ^{Note3}	12		mA	
				f _{xx} =16MHz f _x =16MHz	19		mA	
		Peripheral: f _{xx} /2 PRSI option: 1	PLL: ON 12MHz ≤ f _{xx} ≤ 32MHz	f _{xx} =32MHz f _x =16MHz	31		mA	
HALT mode Note8	IDD2	All peripherals running	Peripheral: f _{xx} PRSI option: 0	PLL: ON 12MHz ≤ f _{xx} ≤ 32MHz	f _{xx} =20MHz f _x =5MHz	16	23	mA
					f _{xx} =32MHz f _x =16MHz	24	34	mA
			PLL: OFF 4MHz ≤ f _{xx} ≤ 16MHz	f _{xx} =8MHz 8MHz Internal-OSC ^{Note3}	8	12	mA	
				f _{xx} =16MHz f _x =16MHz	13	20	mA	
		Peripheral: f _{xx} /2 PRSI option: 1	PLL: ON 12MHz ≤ f _{xx} ≤ 32MHz	f _{xx} =32MHz f _x =16MHz	20	27	mA	
			All peripherals stopped	Peripheral: f _{xx} PRSI option: 0	PLL: ON 12MHz ≤ f _{xx} ≤ 32MHz	f _{xx} =20MHz f _x =5MHz	12	
					f _{xx} =32MHz f _x =16MHz	18		mA
		PLL: OFF 4MHz ≤ f _{xx} ≤ 16MHz		f _{xx} =8MHz 8MHz Internal-OSC ^{Note3}	5		mA	
				f _{xx} =16MHz f _x =16MHz	9		mA	
		Peripheral: f _{xx} /2 PRSI option: 1	PLL: ON 12MHz ≤ f _{xx} ≤ 32MHz	f _{xx} =32MHz f _x =16MHz	17		mA	

Mode	Symbol	Condition			TYP.	MAX.	Unit
IDLE1 mode	IDD3	Peripheral (TAA, UARTD) running	PLL: OFF 4MHz≤f _{xx} ≤16MHz Note7	f _{xx} =5MHz f _x =5MHz	1.4	2.2	mA
				f _{xx} =12MHz f _x =12MHz	2.0	3.1	mA
				f _{xx} =16MHz f _x =16MHz	2.4	3.6	mA
			f _{xx} =8MHz, 8MHz Internal-OSC ^{Note3}	1.5	2.3	mA	
		All peripherals stopped	PLL: OFF 4MHz≤f _{xx} ≤16MHz Note7	f _{xx} =5MHz f _x =5MHz	1.2		mA
				f _{xx} =12MHz f _x =12MHz	1.4		mA
				f _{xx} =16MHz f _x =16MHz	1.6		mA
			f _{xx} =8MHz, 8MHz Internal-OSC ^{Note3}	1.1		mA	
IDLE2 mode	IDD4	PLL: OFF 4MHz≤f _{xx} ≤16MHz Note7	f _{xx} =5MHz f _x =5MHz	0.4	0.7	mA	
			f _{xx} =12MHz f _x =12MHz	0.7	1.0	mA	
			f _{xx} =16MHz f _x =16MHz	0.8	1.2	mA	
		f _{xx} =8MHz, 8MHz Internal-OSC ^{Note3}	0.2	0.5	mA		
SUB operating mode ^{Note5}	IDD5	Crystal resonator (fxt = 32,768kHz)			80	400	μA
		RC resonator (fxt=20kHz) ^{Note6}			80	400	μA
		240 kHz Internal-OSC (SubOSC stopped)			220	1000	μA
SubIDLE mode ^{Note3,5}	IDD6	Crystal resonator (fxt = 32,768kHz)			20	190	μA
		RC resonator (fxt=20kHz) ^{Note6}			40	220	μA
		240kHz Internal-OSC (SubOSC stopped)			25	180	μA
STOP mode ^{Note3,4}	IDD7	POC stop	240kHz Internal-OSC stop		7.5	80	μA
			240kHz Internal-OSC working		15.5	95	μA
		POC work	240kHz Internal-OSC stop		10.5	85	μA
			240kHz Internal-OSC working		18.5	100	μA

(b) Calculation formulas

(Ta = -40 to +85°C, C=4.7uF,

VDD = EVDD = 3.3 to 5.5V, AVREF0 = 3.3 to 5.5V, VSS = EVSS = AVSS = 0V^{Note1)})

Mode	Symbol	Condition		TYP. ^{Note9}	MAX. ^{Note9}	Unit	
Operating mode Note2,8	IDD1	All peripherals running	Peripheral: f _{xx} PRSI option: 0	PLL: ON 12MHz ≤ f _{xx} ≤ 32MHz	0.98·f _{xx} +7.1	1.18·f _{xx} +13.6	mA
				PLL: OFF 4MHz ≤ f _{xx} ≤ 16MHz	0.98·f _{xx} +5.5	1.18·f _{xx} +10.6	mA
			Peripheral: f _{xx} /2 PRSI option: 1	PLL: ON 12MHz ≤ f _{xx} ≤ 32MHz	0.90·f _{xx} +6.0	1.08·f _{xx} +12.2	mA
		All peripherals stopped	Peripheral: f _{xx} PRSI option: 0	PLL: ON 12MHz ≤ f _{xx} ≤ 32MHz	0.81·f _{xx} +6.2		mA
				PLL: OFF 4MHz ≤ f _{xx} ≤ 16MHz	0.83·f _{xx} +5.7		mA
			Peripheral: f _{xx} /2 PRSI option: 1	PLL: ON 12MHz ≤ f _{xx} ≤ 32MHz	0.79·f _{xx} +6.2		mA
HALT mode Note8	IDD2	All peripherals running	Peripheral: f _{xx} PRSI option: 0	PLL: ON 16MHz ≤ f _{xx} ≤ 32MHz	0.67·f _{xx} +3.0	0.90·f _{xx} +5.4	mA
				PLL: OFF 4MHz ≤ f _{xx} ≤ 16MHz	0.70·f _{xx} +1.9	1.00·f _{xx} +4.0	mA
			Peripheral: f _{xx} /2 PRSI option: 1	PLL: ON 16MHz ≤ f _{xx} ≤ 32MHz	0.55·f _{xx} +2.8	0.64·f _{xx} +7.0	mA
		All peripherals stopped	Peripheral: f _{xx} PRSI option: 0	PLL: ON 16MHz ≤ f _{xx} ≤ 32MHz	0.46·f _{xx} +2.8		mA
				PLL: OFF 4MHz ≤ f _{xx} ≤ 16MHz	0.44·f _{xx} +1.6		mA
			Peripheral: f _{xx} /2 PRSI option: 1	PLL: ON 16MHz ≤ f _{xx} ≤ 32MHz	0.46·f _{xx} +1.8		mA
IDLE1 mode	IDD3	Peripheral (TAA, UARTD) running	PLL: OFF 4MHz ≤ f _{xx} ≤ 16MHz	0.092·f _{xx} +0.90	0.128·f _{xx} + 1.35	mA	
		All peripherals stopped	Note7	0.035·f _{xx} +1.01		mA	
IDLE2 mode	IDD4	PLL: OFF 4MHz ≤ f _{xx} ≤ 16MHz ^{Note7}		0.037·f _{xx} +0.21	0.049·f _{xx} + 0.43	mA	

- Notes:**
- VDD and EVDD total current. (Ports are stopped).
AVREF0 current, port buffer current (including a current flowing in the on-chip pull-up/pull-down resistor) are not included.
 - The code flash and the data flash are in read mode.
When the device is in programming mode (Self-programming mode or data flash programming mode), the current value (MAX. value) adds by the following value:
 - Self-programming mode:
 - + In case of PLL OFF: 7-(0.33·f_{xx}+0.1) [mA]
 - + In case of PLL ON: 7-(0.18·f_{xx}+3.0) [mA]
 - Data flash programming mode:
 - + 7-(0.18·f_{xx}/4+3.0) [mA]
 - Main OSC is stopped.
 - Do not use SubOSC.
 - POC is working. 240kHz Internal-OSC is working. 8MHz Internal-OSC is stopped.
 - RC Oscillation frequency is typ.40kHz. This clock is divided by 2 internally.
 - 8MHz Internal-OSC is stopped
 - When the SSCG is running, the current value adds typ +2.5mA, max +4mA.
 - The formulas are for reference only. Not all possible values for f_{xx} are tested in the outgoing device inspection.

2.7 AC Characteristics

AC test Input measurement points (VDD, AVREF0, EVDD)

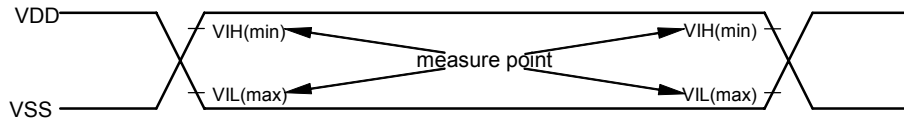

AC test output measurement points

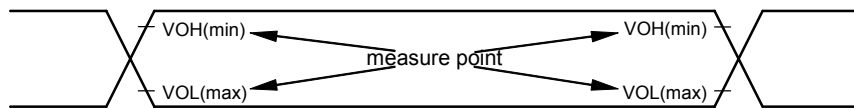

Load conditions

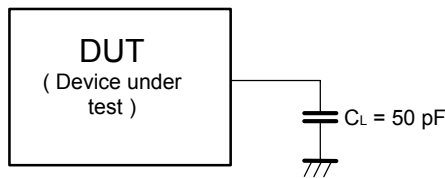

Caution: If the load capacitance exceeds 50pF due to the circuit configuration, reduce the load capacitance of the device to 50pF or less by inserting a buffer or by some other means.

2.7.1 CLKOUT Output Timing

(Ta = -40 to +85°C, VDD = EVDD = 3.5 to 5.5V, AVREF0 = 3.5 to 5.5V, VSS = EVSS = AVSS = 0V, CL=50pF)

Parameter	Symbol	Conditions	MIN.	MAX.	Unit
Output cycle	tCYK	VDD = EVDD = 4.0V ~ 5.5V	31.25ns	80μs	
		VDD = EVDD = 3.5V ~ 5.5V	50ns		
High level width	tWKH	VDD = EVDD = 4.0V ~ 5.5V	tCYK/2-13		ns
		VDD = EVDD = 3.5V ~ 5.5V	tCYK/2-15		
Low level width	tWKL	VDD = EVDD = 4.0V ~ 5.5V	tCYK/2-13		ns
		VDD = EVDD = 3.5V ~ 5.5V	tCYK/2-15		
Rise time	tKR	VDD = EVDD = 4.0V ~ 5.5V		13	ns
		VDD = EVDD = 3.5V ~ 5.5V		15	
Fall time	tKF	VDD = EVDD = 4.0V ~ 5.5V		13	ns
		VDD = EVDD = 3.5V ~ 5.5V		15	

CLKOUT output timing

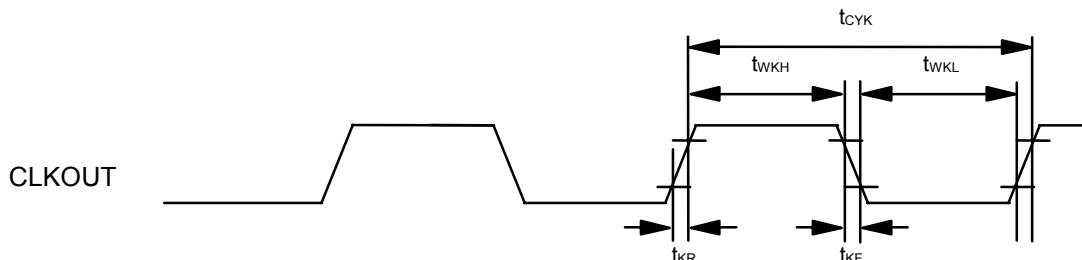

2.7.2 RESET, Interrupt, ADTRG Timing

(Ta = -40 to +85°C, VDD = EVDD = 3.3 to 5.5V, AVREF0 = 3.3 to 5.5V, VSS = EVSS = AVSS = 0V, CL=50pF)

Parameter	Symbol	Conditions	MIN.	TYP.	MAX.	Unit
_RESET input low level width	tWRSL	analog filter	250			ns
NMI input high level width	tWNIH	analog filter	250			ns
NMI input low level width	tWNIL	analog filter	250			ns
INTPn ^{Note1} input high level width	tWITH	analog filter ,n=0-8	250			ns
		digital filter ,n=3	Note2			ns
INTPn ^{Note1} input low level width	tWITL	analog filter ,n=0-8	250			ns
		digital filter ,n=3	Note2			ns

- Notes:** 1. ADTRG is same spec (P03/INTP0/ADTRG). $\overline{\text{DRST}}$ is same spec (P05/INTP2/ $\overline{\text{DRST}}$)
 2. 2Tsamp+20 or 3Tsamp+20 ("Tsamp" is Noise reject sampling clock (NF macro))

- Remarks:** 1. The above minimum values show pulse widths that are surely detected as an effective edge. An effective may also be detected even if the input pulse width is less than the above minimum specification.
 2. $\overline{\text{RESET}}$, NMI, INTPn, ADTRG and $\overline{\text{DRST}}$ have analog noise filter. The typical filter time is typ=60ns.

2.7.3 Key Return Timing

(Ta = -40 to +85°C, VDD = EVDD = 3.3 to 5.5V, AVREF0 = 3.3 to 5.5V, VSS = EVSS = AVSS = 0V, CL=50pF)

Parameter	Symbol	Conditions	MIN.	TYP.	MAX.	Unit
KRn input high level width	tWKRH	analog filter ,n=0-7	250			ns
KRn input low level width	tWKRL	analog filter ,n=0-7	250			ns

- Remarks:** 1. The above minimum values show pulse widths that are surely detected as an effective edge. An effective may also be detected even if the input pulse width is less than the above minimum specification.
 2. KRn inputs have analog noise filter. The typical filter time is typ=60ns.

2.7.4 Timer Timing

(Ta = -40 to +85°C, VDD = EVDD = 3.5 to 5.5V, AVREF0 = 3.5 to 5.5V, VSS = EVSS = AVSS = 0V, CL=50pF)

Parameter	Symbol	Conditions	MIN.	TYP.	MAX.	Unit
TI input high level width	tTIH	TIAA00-01,10-11,20-21,30-31,40-41 ^{Note1} TIAB00-03 ^{Note1}	250			ns
TI input low level width	tTIL	TIAA00-01,10-11,20-21,30-31,40-41 ^{Note1} TIAB00-03 ^{Note1}	250			ns
TO output cycle	tTCYK	TIAA00-01,10-11,20-21,30-31, 40-41 ^{Note1} TIAB00-03 ^{Note1}	4.0V ≤ VDD ≤ 5.5V		16	MHz
			3.5V ≤ VDD < 4.0V		10	MHz

- Notes:** 1. Except for the external trigger and external event function.

- Remarks:** 1. The above minimum values show pulse widths that are surely detected as an effective edge. An effective may also be detected even if the input pulse width is less than the above minimum specification.
 2. TIAAn and TIABn inputs have analog noise filter. The typical filter time is typ=60ns.

2.7.5 CSI Timing

(a) Master mode

($T_a = -40$ to $+85^\circ\text{C}$, $V_{DD} = EV_{DD} = 3.5$ to 5.5V , $AV_{REF0} = 3.5$ to 5.5V , $V_{SS} = EV_{SS} = AV_{SS} = 0\text{V}$, $CL=50\text{pF}$)

Parameter	Symbol	Conditions	MIN.	MAX.	Unit
SCKBn cycle time	tKCY1		125		ns
SCKBn high level width	tKH1		tKCY1/2-15		ns
SCKBn low level width	tKL1		tKCY1/2-15		ns
SIBn setup time (to SCKBn)	tSIK1		30		ns
SIBn hold time (from SCKBn)	tKSI1		25		ns
Delay time from SCKBn to SOBn	tKSO1			25	ns

(b) Slave mode

($T_a = -40$ to $+85^\circ\text{C}$, $V_{DD} = EV_{DD} = 3.5$ to 5.5V , $AV_{REF0} = 3.5$ to 5.5V , $V_{SS} = EV_{SS} = AV_{SS} = 0\text{V}$, $CL=50\text{pF}$)

Parameter	Symbol	Conditions	MIN.	MAX.	Unit
SCKBn cycle time	tKCY1		200		ns
SCKBn high level width	tKH1		90		ns
SCKBn low level width	tKL1		90		ns
SIBn setup time (to SCKBn)	tSIK1		50		ns
SIBn hold time (from SCKBn)	tKSI1		50		ns
Delay time from SCKBn to SOBn	tKSO1			50	ns

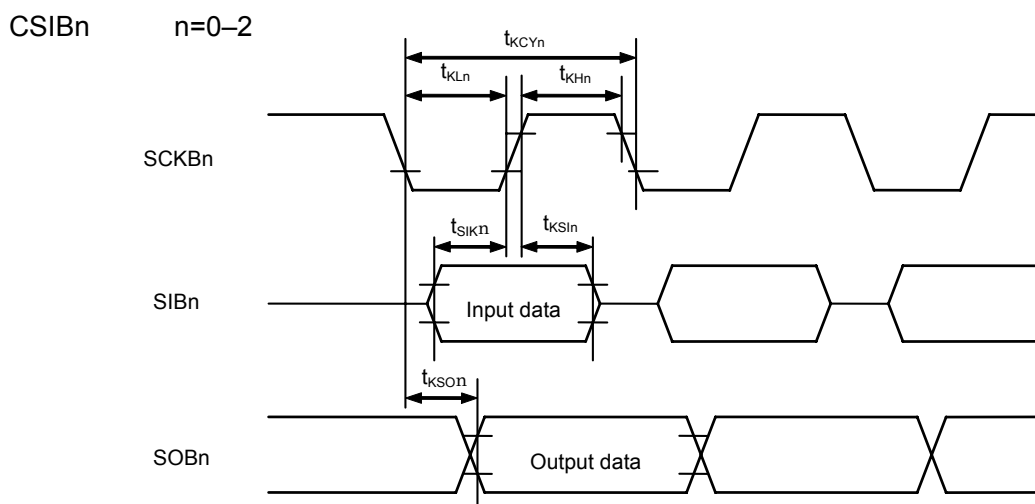

2.7.6 UART Timing

($T_a = -40$ to $+85^\circ\text{C}$, $V_{DD} = EV_{DD} = 3.5$ to 5.5V , $AV_{REF0} = 3.5$ to 5.5V , $V_{SS} = EV_{SS} = AV_{SS} = 0\text{V}$, $CL=50\text{pF}$)

Parameter	Symbol	Conditions	MIN.	TYP.	MAX.	Unit
Transfer rate					1.5	Mbps
ASCK0 frequency					10	MHz

2.7.7 IIC Timing

(Ta = -40 to +85°C, VDD = EVDD = 3.5 to 5.5V, AVREF0 = 3.5 to 5.5V, VSS = EVSS = AVSS = 0V, CL=50pF)

Parameter	Symbol	Normal mode		High-speed mode		Unit
		min.	max.	min.	max.	
SCL00 clock frequency	fCLK	0	100	0	400	kHz
Bus-free time (between stop/start conditions)	tBUF	4.7		1.3		us
Hold time ^{Note1}	tHD:STA	4.0		0.6		us
SCL00 clock low-level width	tLOW	4.7		1.3		us
SCL00 clock high-level width	tHIGH	4.0		0.6		us
Setup time for start/restart conditions	tSU:STA	4.7		0.6		us
Data hold time	CBUS compatible master	5.0				us
	IIC mode	tHD:DAT	0 ^{Note2}	0 ^{Note2}	0.9 ^{Note3}	us
Data setup time	tSU:DAT	250		100 ^{Note4}		ns
SDA00 and SCL00 signal rise time	tR		1000	20+0.1Cb	300	ns
SDA00 and SCL00 signal fall time	tF		300	20+0.1Cb	300	ns
Stop condition setup time	tSU:STO	4.0		0.6		us
Pulse width with spike suppressed by input filter	tSP			0	50	ns
Capacitance load of each bus line	Cb		400		400	pF

- Notes:**
- At the start condition, the first clock pulse is generated after the hold time
 - The system requires a minimum of 300ns hold time Internally for the SDA signal (at VIH-min. of SCL00 signal)
In order to occupy the undefined area at the falling edge of SCL00.
 - If the system does not extend the SCL00 signal low hold time (tLOW), only the maximum data hold time (tHD:DAT) needs to be satisfied.
 - The high-speed-mode IIC bus can be used In a normal-mode IIC bus system.
In this case, set the high-speed-mode IIC bus so that It meets the following conditions.
- If the system does not extend the SCL00 signal's low state hold time:
SU:DAT?250ns
- If the system extends the SCL00 signal's low state hold time:
Transmit the following data bit to the SDA00 line prior to releasing the SCL00 line
(tRmax.+tSU:DAT=1000+250=1250ns: Normal mode IIC bus specification).
 - Cb: Total capacitance of one bus line (unit: pF)

IIC bus interface timing

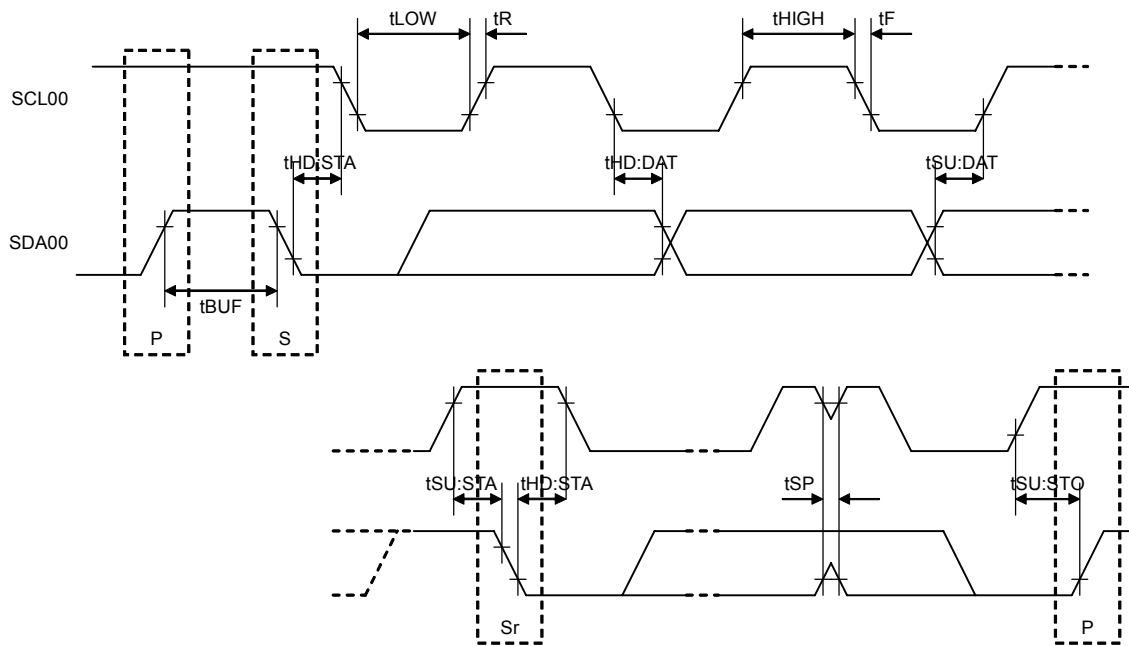

Remark: P: Stop condition
 S: Start condition
 Sr: Restart condition

2.7.8 CAN Timing

(Ta = -40 to +85°C, VDD = EVDD = 3.5 to 5.5V, AVREF0 = 3.5 to 5.5V, VSS = EVSS = AVSS = 0V, CL=50pF)

Parameter	Symbol	Conditions	MIN.	TYP.	MAX.	Unit
Transfer rate					1	Mbps
Internal delay time					100	ns

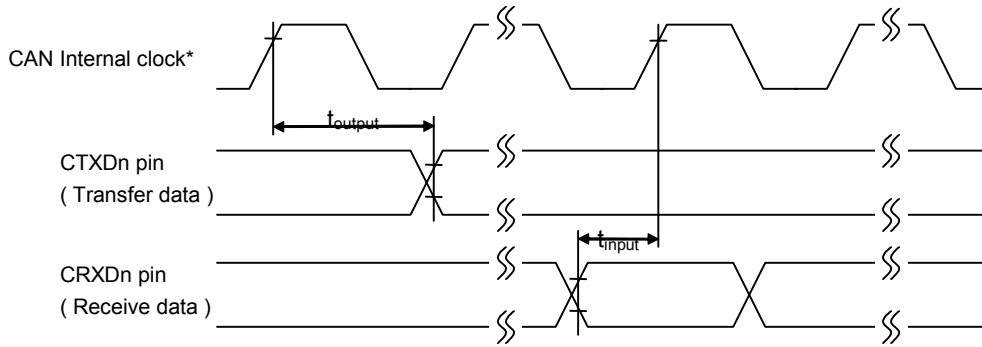

Internal delay time (tNODE)= Internal Transfer Delay(t_{output}) + Internal Receive Delay(t_{input})

*) CAN Internal clock (f_{CAN}):CAN baud rate clock

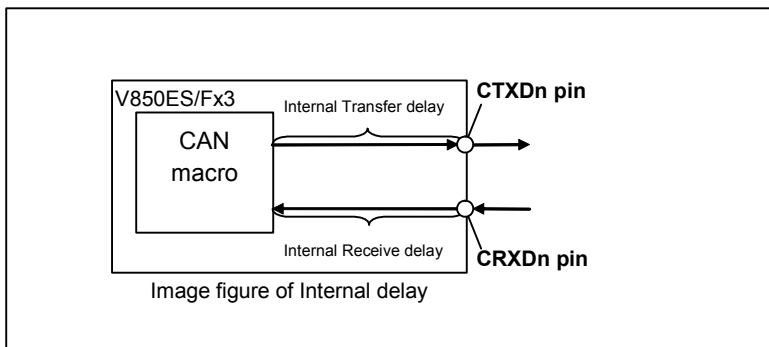

2.8 A/D Converter

(Ta = -40 to +85°C, C=4.7uF, VDD = EVDD = 3.5 to 5.5V, AVREF0 = 4.0 to 5.5V, VSS = EVSS = AVSS = 0V)

Parameter	Symbol	Conditions	MIN.	TYP.	MAX.	Unit
Resolution					10	bit
Overall error ^{Note1}		4.0V≤AVREF0<5.5V		±0.15	±0.3	%FSR
Conversion time	tCONV		3.10		16	μs
Stabilization time	tSTA	After ADA0PS bit = 0 -> 1	2			μs
Recovery time for power down mode	tDPU		1			μs
Zero-scale error ^{Note1}	ZSE				±0.3	%FSR
Full-scale error ^{Note1}	FSE				±0.3	%FSR
Integral non-linearity error ^{Note2}	INL				±2.5	LSB
Differential non-linearity error ^{Note2}	DNL				±1.5	LSB
Analog input voltage	VIAN		AVSS		AVREF0	V
Analog input equivalent circuit capacitance ^{Note3,4}	CINA				6.19	pF
Analog input equivalent circuit resistance ^{Note3}	RINA				2.55	kΩ
AVREF0 current	IAREF0	A/D operating		4	7	mA
		A/D operation stop		1	10	uA
Conversion result when using Diagnostic function		AVREF0 conversion	3FC		3FF	HEX
		AVSS conversion	000		003	HEX

- Notes:**
1. Overall error excluding quantization error (±0.05%FSE). It is indicated as a ratio to the full-scale value.
 2. Excluding quantization error (±1/2 LSB)
 3. Not tested in production.
 4. Does not include input/output capacitance CIO

2.9 POC

(Ta = -40 to +85°C, C=4.7uF, VDD = EVDD, VSS = EVSS = AVSS = 0V)

Parameter	Symbol	Conditions	MIN.	TYP.	MAX.	Unit
Detect voltage	VPOC0		3.3	3.5	3.7	V
Supply voltage rise time	tPTH	From VDD=0V to VDD=3.3V	0.002			ms
Response time1 ^{Note1}	tPTHd	In case of power on. After VDD reaches 3.7V.			2.0	ms
Response time2 ^{Note2}	tPD	In case of power off. After VDD drop 3.3V.		0.2	1.0	ms
VDD minimum width	tPW		0.2			ms

- Notes:** 1. From detect voltage to release reset signal
 2. From detect voltage to occurrence of reset signal

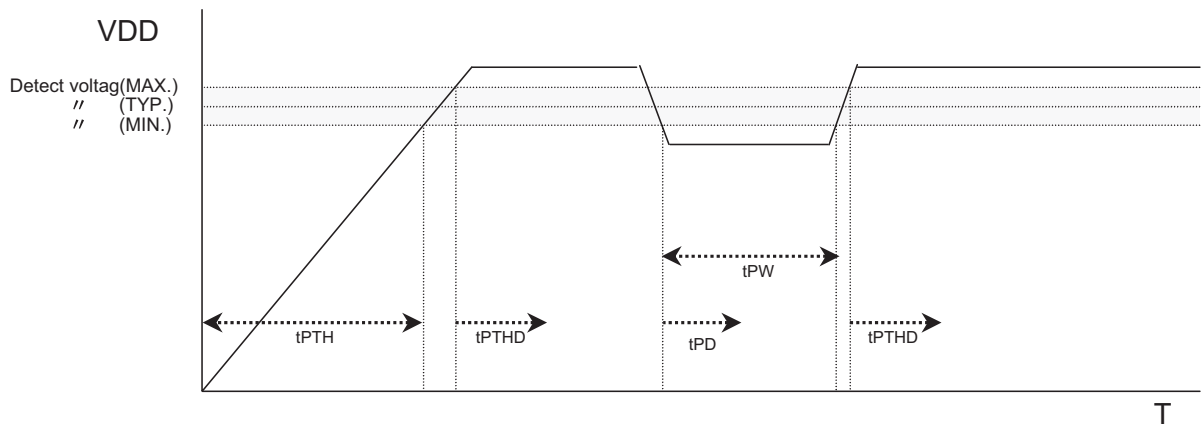

Note: POC is available only in M2 devices. Refer to 'Ordering information' in the V850ES/Fx3 User's Manual.

2.10 LVI

(Ta = -40 to +85°C, C=4.7uF, VDD = EVDD = 3.3 to 5.5V, AVREF0 = 3.3 to 5.5V, VSS = EVSS = AVSS = 0V)

Parameter	Symbol	Conditions	MIN.	TYP.	MAX.	Unit
Detect voltage	VLVI0		3.8	4.0	4.2	V
	VLVI1		3.5	3.7	3.9	V
Response time ^{Note1}	tLD	After VDD reaches VLVI0/1(max). After VDD drop VLVI0/1(min).		0.2	2.0	ms
VDD minimum width	tLW		0.2			ms
Reference voltage stabilization wait time ^{Note2}	tLWAIT	After VDD reaches 3.3V. After LVION bit (LVIM.bit7) = 0->1		0.1	0.2	ms

- Notes:** 1. From detect voltage to occurrence interrupt/reset signal
 2. If POC functionality is available, the wait time is not needed.

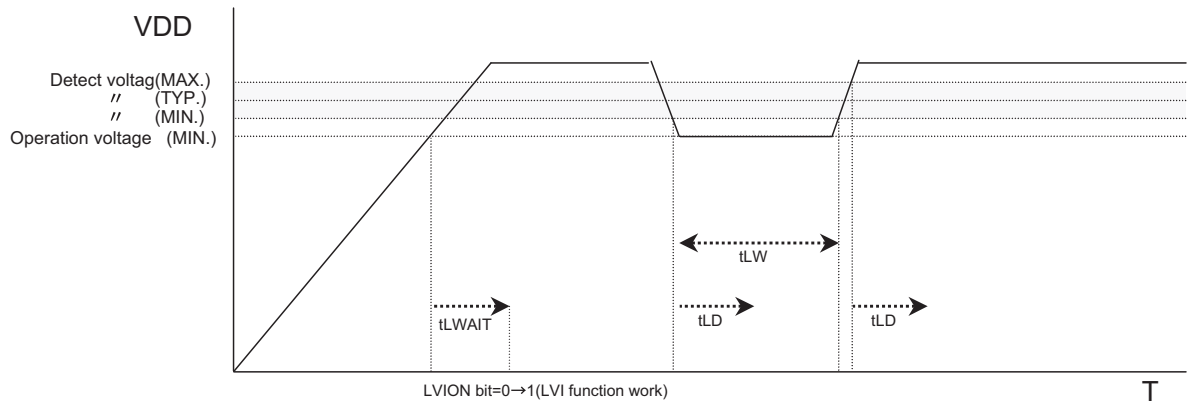

2.11 RAM Retention Flag

(Ta = -40 to +85°C, C=4.7uF, VDD = EVDD = 1.9 to 5.5V, VSS = EVSS = AVSS = 0V)

Parameter	Symbol	Conditions	MIN.	TYP.	MAX.	Unit
Detect voltage	VRAMH		1.9	2.0	2.1	V
Supply voltage rise time	tRAMHTH	From VDD=0V to VDD=3.3V	0.002		1800	ms
Response time ^{Note1}	tRAMHD	After VDD reaches 2.1V.		0.2	2.0	ms
VDD minimum width	tRAMHW		0.2			ms

- Notes:** 1. From detect voltage to set RAMFbit (RAMS.bit0)

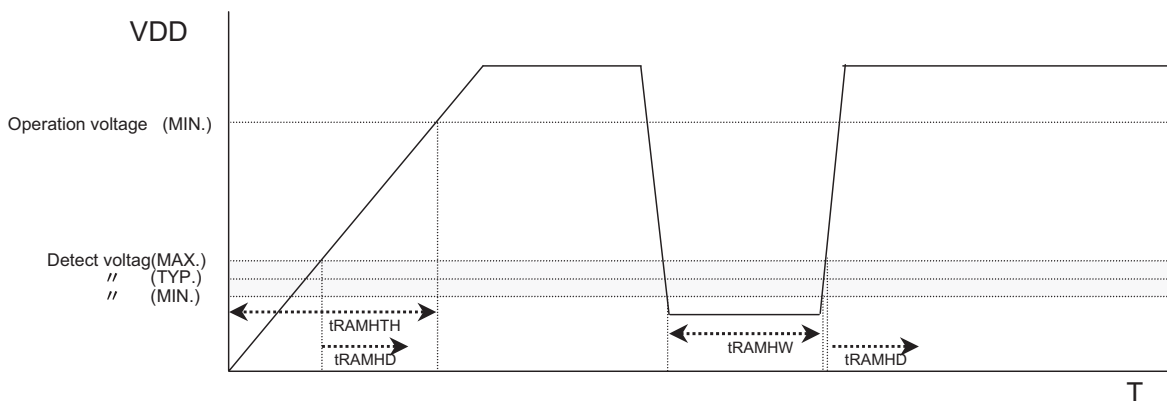

2.12 Data Retention Characteristics

(Ta = -40 to +85°C, C=4.7uF, VDD = EVDD = 1.9 to 5.5V, VSS = EVSS = AVSS = 0V) (

Parameter	Symbol	Conditions	MIN.	TYP.	MAX.	Unit
Data retention power supply voltage	VDDDR	STOP mode (All function is stopped)	1.9		5.5	V
Data retention power supply current	IDDDR	VDDDR=2.0V(All function is stopped)		6.5	70	μA
Supply voltage rise time	tRVD		1			μs
Supply voltage fall time	tFVD		1			μs
Supply voltage hold time	tHVD	After STOP mode	0			ms
STOP release signal input time	tDREL	After VDD reaches operating voltage range MIN. 3.3V	0			ms
Data retention high-level input voltage	VIHDR	All input port	0.9VDDDR		VDDDR	V
Data retention low-level input voltage	VILDRL	All input port	0		0.1VDDDR	V

Remark: When STOP mode is entered/released operation voltage range must be controlled.

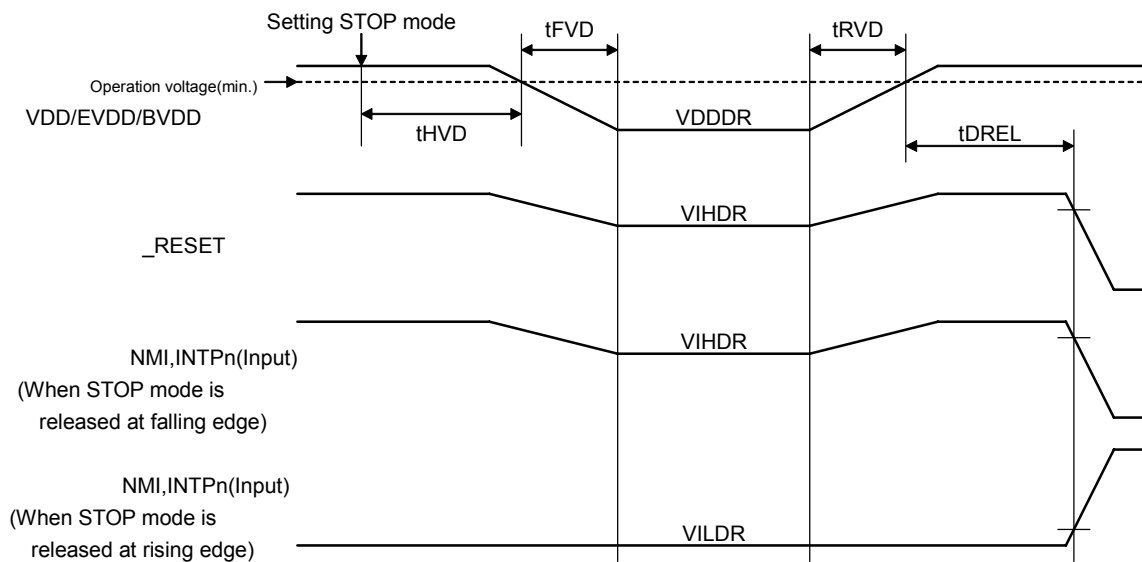

2.13 Flash Memory Programming Characteristics

(a) Basic Characteristics

(C=4.7uF, VDD = EVDD, AVREF0 = 3.5 to 5.5V, VSS = EVSS = AVSS = 0V)

Parameter	Symbol	Conditions	MIN.	TYP.	MAX.	Unit
Operation frequency	fCPU		4		32	MHz
Supply voltage	VDD		3.3		5.5	V
Number of rewrites	CWRT1	Code Flash	1000			count
	CWRT2	Data Flash				
High level input voltage	VIH	FLMD0	0.8EVDD		EVDD	V
Low level input voltage	VIL	FLMD0	EVSS		0.2EVDD	V
Programming temperature	tPRG		-40		+85	°C
Data retention		Code Flash			15 ^{Note1}	year
		Data Flash			5 ^{Note2}	

- Notes:**
- Under the condition of CWRT1
 - Under the condition of CWRT2

Remark: The initial write when the product is shipped, any erase → write set of operations, or any programming operation is counted as one rewrite.

Example: P: Program(write) E: Erase

Product is shipped → P → E → P → E → P : Rewrite count: 3

Product is shipped → E → P → E → P → E → P : Rewrite count: 3

(b) Serial Writing Operation Characteristics

(Ta = -40 to +85°C, C=4.7uF, VDD = EVDD, AVREF0 = 3.5 to 5.5V, VSS = EVSS = AVSS = 0V, CL=50pF)

Parameter	Symbol	Conditions	MIN.	TYP.	MAX.	Unit
FLMD0 setup time (from VDD)	tDP		1			ms
RESET release (from FLMD0)	tPR		2			ms
FLMD0 pulse input start (from raise edge of _RESET)	tRP		800			μs
FLMD0 high level width / low level width	tPW		10		100	μs
FLMD0 raise time	tR				50	ns
FLMD0 fall time	tF				50	ns

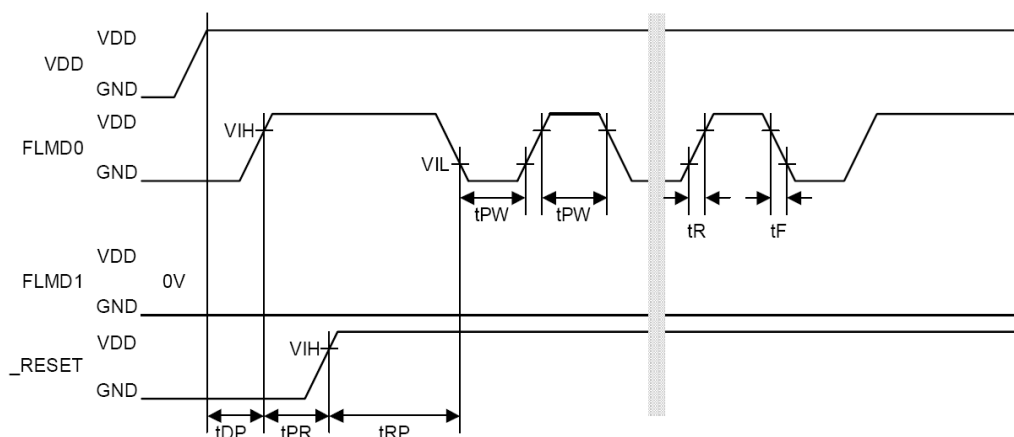

3. Electrical Specifications of (A1)-Grade

This product has to be used only under the conditions of VDD=EVDD. Operation is not ensured at the time of using this product except this condition.

3.1 Absolute Maximum Ratings

Absolute Maximum Ratings (Ta=25°C)

Parameter	Symbol	Conditions	Rating	Unit	
Supply voltage	VDD	VDD=EVDD,	-0.5 to +6.5	V	
	EVDD	VDD=EVDD	-0.5 to +6.5	V	
	AVREF0		-0.5 to +6.5	V	
	VSS	VSS=EVSS=AVSS	-0.5 to +0.5	V	
	EVSS	VSS=EVSS=AVSS	-0.5 to +0.5	V	
	AVSS	VSS=EVSS=AVSS	-0.5 to +0.5	V	
Input voltage	VI1	Pin Group 1x, 2x, 6	-0.5 to EVDD+0.5 Note1	V	
	VI3	Pin Group 7	-0.5 to VRO+0.5 Note1	V	
Analog input voltage	VIAN	Pin Group 4	-0.5 to AVREF0+0.5 Note1	V	
High level output current	IOH	Pin Group 1x, 2x	1 pin	-4	mA
			Total	-20	mA
		Pin Group 4	1 pin	-4	mA
			Total	-10 ^{Note2}	mA
Low level output current	IOL	Pin Group 1x, 2x	1 pin	4	mA
			Total	20	mA
		Pin Group 4	1 pin	4	mA
			Total	10 ^{Note2}	mA
Operating ambient temperature	Ta	Normal operating mode	-40 to +110	°C	
		Flash programming mode	-40 to +110		
Storage temperature	Tstg		-40 to +125	°C	

Remarks: 1. The characteristics of the dual-function pins are the same as those of the port pins unless otherwise specified

Notes: 1. Be sure not to exceed the absolute maximum ratings (Max. value) of each supply voltage.
2. Excluding ADC0 IAREF0 current.

3.2 Capacities

Specification is identical to that from (A)-Grade except Ta=-40 to +110°C.

3.3 Operating condition

Specification is identical to that from (A)-Grade except Ta=-40 to +110°C.

3.4 Voltage Regulator Characteristics

Specification is identical to that from (A)-Grade except Ta=-40 to +110°C.

3.5 Clock Generator Circuit

3.5.1 Main System Clock Oscillation Circuit Characteristics

Specification is identical to that from (A)-Grade except Ta=-40 to +110°C.

3.5.2 Sub System Clock Oscillation Circuit Characteristics

(Ta = -40 to +110°C, C=4.7uF, VDD = EVDD = 3.3 to 5.5V, AVREF0 = 3.3 to 5.5V, VSS = EVSS = AVSS = 0V)

Resonator	Recommended Circuit	Parameter	Conditions	MIN.	TYP.	MAX.	Unit
RC resonator	Refer to Figure 2	Oscillator frequency ^{Note1,4}	R=390KΩ ±5% ^{Note3} , C=47pF±10% ^{Note3}	25	40	55	kHz
		Oscillation stabilization time ^{Note2}				100	μs

- Notes:**
1. Indicates only oscillation circuit characteristics. Refer to "AC Characteristic" for cpu operation clock.
 2. Time required to stabilize oscillation after VDD reaches oscillator voltage range min. 3.3V
 3. In order to avoid the influence of wiring capacity, shorten wiring as much as possible.
 4. RC Oscillation frequency is typ. 40kHz. This clock is divided by 2 internally. In case of RC Oscillator, internal system clock frequency(fxt) is min. 12.5kHz, typ. 20kHz, max. 27.5kHz.

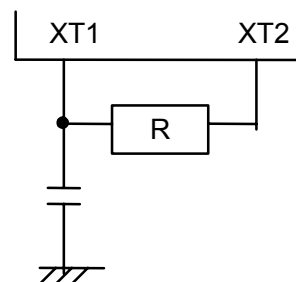

3.5.3 Internal-OSC Characteristics

Specification is identical to that from (A)-Grade except Ta=-40 to +110°C.

3.5.4 PLL Characteristics

Specification is identical to that from (A)-Grade except Ta=-40 to +110°C.

3.5.5 SSCG Characteristics

Specification is identical to that from (A)-Grade except Ta=-40 to +110°C.

3.6 DC Characteristics

3.6.1 Input/Output Level

(Ta = -40 to +110°C, C=4.7uF, VDD = EVDD = 3.3 to 5.5V, AVREF0 = 3.3 to 5.5V, VSS = EVSS = AVSS = 0V)

Parameter	Symbol	Conditions	MIN.	TYP.	MAX.	Unit	
High level input voltage	VIH1	Pin Group 1B	0.7·EVDD		EVDD	V	
	VIH2	Pin Group 1D	0.8·EVDD		EVDD	V	
		Pin Group 2D	0.8·EVDD		EVDD	V	
	VIH3	Pin Group 2A	0.7·EVDD		EVDD	V	
	VIH4	Pin Group 4	0.7·AVREF0		AVREF0	V	
VIH5	Pin Group 6	0.8·EVDD		EVDD	V		
Low level input voltage	VIL1	Pin Group 1B	EVSS		0.3·EVDD	V	
	VIL2	Pin Group 1D	EVSS		0.4·EVDD	V	
		Pin Group 2D	EVSS		0.4·EVDD	V	
	VIL3	Pin Group 2A	EVSS		0.3·EVDD	V	
	VIL4	Pin Group 4	AVSS		0.3·AVREF0	V	
VIL5	Pin Group 6	EVSS		0.2·EVDD	V		
Input hysteresis	VHYS1	Pin Group 1B	Center point at 0.5 x EVDD ^{Note3}		0.267 x EVDD - 0.51V	V	
	VHYS2	Pin Group 1D	Center point at 0.6 x EVDD ^{Note3}		0.192 x EVDD - 0.31V	V	
		Pin Group 2D	Center point at 0.6 x EVDD ^{Note3}		0.192 x EVDD - 0.31V	V	
	VHYS5	Pin Group 6	Center point at 0.5 x EVDD ^{Note3}		0.535 x EVDD - 0.9V	V	
High level output voltage ^{Note2}	VOH1	Pin Group 1x, 2x	IOH=-1.0mA	EVDD-1.0		EVDD	V
			IOH=-100uA	EVDD-0.5		EVDD	V
	VOH3	Pin Group 4	IOH=-1.0mA	AVREF0-1.0		AVREF0	V
			IOH=-100uA	AVREF0-0.5		AVREF0	V
Low level output voltage ^{Note2}	VOL1	Pin Group 1x, 2x	IOL=1.0mA	0		0.4	V
		P914, 915	IOL=3.0mA				
	VOL3	Pin Group 4	IOL=1.0mA	0		0.4	V
Software pull-up resistor	R1	VI=0V	10	30	100	kΩ	
Software ^{Note1} pull-down resistor	R2	VI=VDD	10	30	100	kΩ	

Remark: The characteristics of the dual-function pins are the same as those of the port pins unless otherwise specified.

- Notes:**
1. $\overline{\text{DRST}}$ terminal only. (Control register is OCDM)
 2. Total IOH/IOL max is 20mA/-20mA for the power supply line EVDD.
Total IOH/IOL max is 10mA/-10mA for the power supply line AVREF0.
AVREF0 IOH/IOL current is excluding ADC0 current IAREF0.
 3. Typical value. Not tested and guaranteed

3.6.2 PIN leakage current

(Ta = -40 to +110°C, C=4.7uF, VDD = EVDD = 3.3 to 5.5V, AVREF0 = 3.3 to 5.5V, VSS = EVSS = AVSS = 0V)

Parameter	Symbol	Conditions	MIN.	TYP.	MAX.	Unit
High level input leakage current	ILIH1	VI=VDD	Analog pins		0.4	uA
			Other pins ^{Note1}		0.8	
Low level input leakage current	ILIL1	VI=0V	Analog pins		-0.4	
			Other pins ^{Note1}		-0.8	
High level output leakage current	ILOH1	VO=VDD	Analog pins		0.4	
			Other pins		0.8	
Low level output leakage current	ILOL1	VO=0V	Analog pins		-0.4	
			Other pins		-0.8	

Notes: 1. The input leakage current of FLMD0 is as follows:
 High level input leakage current : 4.0uA
 Low level input leakage current : -4.0uA

3.6.3 Power supply current (A1-grade)

3.6.3.1 FE3 128KB μ PD70F3370A, FE3 256KB μ PD70F3371

(a) Absolute values

(Ta = -40 to +110°C, C=4.7 μ F,

VDD = EVDD = 3.3 to 5.5V, AVREF0 = 3.3 to 5.5V, VSS = EVSS = AVSS = 0V^{Note1)})

Mode	Symbol	Condition				TYP.	MAX.	Unit
Operating mode Note2,8	IDD1	All peripherals running	Peripheral: f _{xx} PRSI option: 0	PLL: ON 12MHz ≤ f _{xx} ≤ 32MHz	f _{xx} =20MHz f _x =5MHz	27	37	mA
					f _{xx} =32MHz f _x =16MHz	39	51	mA
			PLL: OFF 4MHz ≤ f _{xx} ≤ 16MHz	f _{xx} =8MHz 8MHz Internal-OSC ^{Note3}	13	20	mA	
				f _{xx} =16MHz f _x =16MHz	21	30	mA	
		Peripheral: f _{xx} /2 PRSI option: 1	PLL: ON 12MHz ≤ f _{xx} ≤ 32MHz	f _{xx} =32MHz f _x =16MHz	35	47	mA	
			All peripherals stopped	Peripheral: f _{xx} PRSI option: 0	PLL: ON 12MHz ≤ f _{xx} ≤ 32MHz	f _{xx} =20MHz f _x =5MHz	22	
					f _{xx} =32MHz f _x =16MHz	32		mA
		PLL: OFF 4MHz ≤ f _{xx} ≤ 16MHz		f _{xx} =8MHz 8MHz Internal-OSC ^{Note3}	12		mA	
				f _{xx} =16MHz f _x =16MHz	19		mA	
		Peripheral: f _{xx} /2 PRSI option: 1	PLL: ON 12MHz ≤ f _{xx} ≤ 32MHz	f _{xx} =32MHz f _x =16MHz	31		mA	
HALT mode Note8	IDD2	All peripherals running	Peripheral: f _{xx} PRSI option: 0	PLL: ON 12MHz ≤ f _{xx} ≤ 32MHz	f _{xx} =20MHz f _x =5MHz	16	23	mA
					f _{xx} =32MHz f _x =16MHz	24	34	mA
			PLL: OFF 4MHz ≤ f _{xx} ≤ 16MHz	f _{xx} =8MHz 8MHz Internal-OSC ^{Note3}	8	12	mA	
				f _{xx} =16MHz f _x =16MHz	13	20	mA	
		Peripheral: f _{xx} /2 PRSI option: 1	PLL: ON 12MHz ≤ f _{xx} ≤ 32MHz	f _{xx} =32MHz f _x =16MHz	20	27	mA	
			All peripherals stopped	Peripheral: f _{xx} PRSI option: 0	PLL: ON 12MHz ≤ f _{xx} ≤ 32MHz	f _{xx} =20MHz f _x =5MHz	12	
					f _{xx} =32MHz f _x =16MHz	18		mA
		PLL: OFF 4MHz ≤ f _{xx} ≤ 16MHz		f _{xx} =8MHz 8MHz Internal-OSC ^{Note3}	5		mA	
				f _{xx} =16MHz f _x =16MHz	9		mA	
		Peripheral: f _{xx} /2 PRSI option: 1	PLL: ON 12MHz ≤ f _{xx} ≤ 32MHz	f _{xx} =32MHz f _x =16MHz	17		mA	

Mode	Symbol	Condition			TYP.	MAX.	Unit	
IDLE1 mode	IDD3	Peripheral (TAA, UARTD) running	PLL: OFF 4MHz≤f _{xx} ≤16MHz Note7	f _{xx} =5MHz f _x =5MHz	1.4	2.5	mA	
				f _{xx} =12MHz f _x =12MHz	2.0	3.4	mA	
				f _{xx} =16MHz f _x =16MHz	2.4	3.9	mA	
		f _{xx} =8MHz, 8MHz Internal-OSC ^{Note3}				1.5	2.6	mA
		All peripherals stopped	PLL: OFF 4MHz≤f _{xx} ≤16MHz Note7		f _{xx} =5MHz f _x =5MHz	1.2		mA
					f _{xx} =12MHz f _x =12MHz	1.4		mA
					f _{xx} =16MHz f _x =16MHz	1.6		mA
f _{xx} =8MHz, 8MHz Internal-OSC ^{Note3}					1.1		mA	
IDLE2 mode	IDD4	PLL: OFF 4MHz≤f _{xx} ≤16MHz Note7		f _{xx} =5MHz f _x =5MHz	0.4	0.9	mA	
				f _{xx} =12MHz f _x =12MHz	0.7	1.2	mA	
				f _{xx} =16MHz f _x =16MHz	0.8	1.4	mA	
		f _{xx} =8MHz, 8MHz Internal-OSC ^{Note3}				0.2	0.7	mA
SUB operating mode ^{Note5}	IDD5	RC resonator (f _{xt} =20kHz) ^{Note6}			80	600	μA	
		240 kHz Internal-OSC (SubOSC stopped)			220	1200	μA	
SubIDLE mode ^{Note3,4}	IDD6	RC resonator (f _{xt} =20kHz) ^{Note6}			40	420	μA	
		240kHz Internal-OSC (SubOSC stopped)			25	380	μA	
STOP mode ^{Note3,4}	IDD7	POC stop	240kHz Internal-OSC stop		7.5	280	μA	
			240kHz Internal-OSC working		15.5	295	μA	
		POC work	240kHz Internal-OSC stop		10.5	285	μA	
			240kHz Internal-OSC working		18.5	300	μA	

(b) Calculation formulas

(Ta = -40 to +110°C, C=4.7uF,

VDD = EVDD = 3.3 to 5.5V, AVREF0 = 3.3 to 5.5V, VSS = EVSS = AVSS = 0V^{Note1})

Mode	Symbol	Condition		TYP. ^{Note9}	MAX. ^{Note3}	Unit		
Operating mode Note2,8	IDD1	All peripherals running	Peripheral: f _{xx} PRSI option: 0	PLL: ON 12MHz ≤ f _{xx} ≤ 32MHz	0.98·f _{xx} +7.1	1.18·f _{xx} +13.6	mA	
				PLL: OFF 4MHz ≤ f _{xx} ≤ 16MHz	0.98·f _{xx} +5.5	1.18·f _{xx} +10.6	mA	
			Peripheral: f _{xx} /2 PRSI option: 1	PLL: ON 12MHz ≤ f _{xx} ≤ 32MHz	0.90·f _{xx} +6.0	1.08·f _{xx} +12.2	mA	
		All peripherals stopped		Peripheral: f _{xx} PRSI option: 0	PLL: ON 12MHz ≤ f _{xx} ≤ 32MHz	0.81·f _{xx} +6.2		mA
					PLL: OFF 4MHz ≤ f _{xx} ≤ 16MHz	0.83·f _{xx} +5.7		mA
				Peripheral: f _{xx} /2 PRSI option: 1	PLL: ON 12MHz ≤ f _{xx} ≤ 32MHz	0.79·f _{xx} +6.2		mA
HALT mode Note8	IDD2	All peripherals running	Peripheral: f _{xx} PRSI option: 0	PLL: ON 16MHz ≤ f _{xx} ≤ 32MHz	0.67·f _{xx} +3.0	0.90·f _{xx} +5.4	mA	
				PLL: OFF 4MHz ≤ f _{xx} ≤ 16MHz	0.70·f _{xx} +1.9	1.00·f _{xx} +4.0	mA	
			Peripheral: f _{xx} /2 PRSI option: 1	PLL: ON 16MHz ≤ f _{xx} ≤ 32MHz	0.55·f _{xx} +2.8	0.64·f _{xx} +7.0	mA	
		All peripherals stopped		Peripheral: f _{xx} PRSI option: 0	PLL: ON 16MHz ≤ f _{xx} ≤ 32MHz	0.46·f _{xx} +2.8		mA
					PLL: OFF 4MHz ≤ f _{xx} ≤ 16MHz	0.44·f _{xx} +1.6		mA
				Peripheral: f _{xx} /2 PRSI option: 1	PLL: ON 16MHz ≤ f _{xx} ≤ 32MHz	0.46·f _{xx} +1.8		mA
IDLE1 mode	IDD3	Peripheral (TAA, UARTD) running	PLL: OFF 4MHz ≤ f _{xx} ≤ 16MHz	0.092·f _{xx} +0.90	0.128·f _{xx} +1.82	mA		
		All peripherals stopped	Note7	0.035·f _{xx} +1.01		mA		
IDLE2 mode	IDD4	PLL: OFF 4MHz ≤ f _{xx} ≤ 16MHz ^{Note7}		0.037·f _{xx} +0.21	0.049·f _{xx} +0.63	mA		

Notes: 1. VDD and EVDD total current. (Ports are stopped).

AVREF0 current, port buffer current (including a current flowing in the on-chip pull-up/pull-down resistor) are not included.

2. The code flash and the data flash are in read mode.

When the device is in programming mode (Self-programming mode or data flash programming mode), the current value (MAX. value) adds by the following value:

- Self-programming mode:

- + In case of PLL OFF: 7-(0.33·f_{xx}+0.1) [mA]

- + In case of PLL ON: 7-(0.18·f_{xx}+3.0) [mA]

- Data flash programming mode:

- + 7-(0.18·f_{xx}/4+3.0) [mA]

3. Main OSC is stopped.**4.** Do not use SubOSC.**5.** POC is working. 240kHz Internal-OSC is working. 8MHz Internal-OSC is stopped.**6.** RC Oscillation frequency is typ.40kHz. This clock is divided by 2 internally.**7.** 8MHz Internal-OSC is stopped**8.** When the SSCG is running, the current value adds typ +2.5mA, max +4mA.**9.** The formulas are for reference only. Not all possible values for f_{xx} are tested in the outgoing device inspection.

3.7 AC Characteristics

AC test Input measurement points (VDD, AVREF0, EVDD)

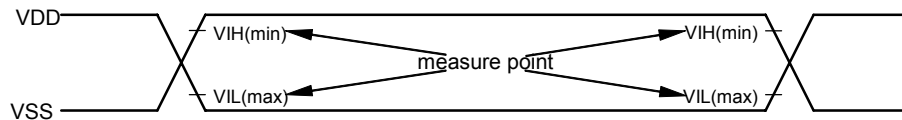

AC test output measurement points

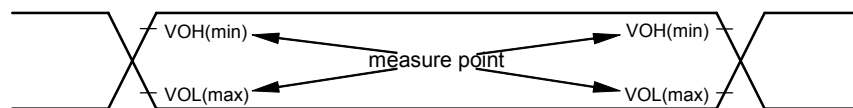

Load conditions

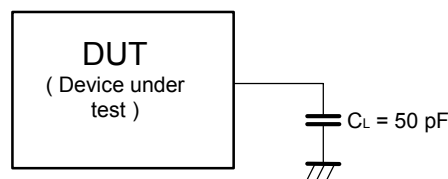

Caution: If the load capacitance exceeds 50pF due to the circuit configuration, reduce the load capacitance of the device to 50pF or less by inserting a buffer or by some other means.

3.7.1 CLKOUT Output Timing

Specification is identical to that from (A)-Grade except Ta=-40 to +110°C.

3.7.2 RESET, Interrupt, ADTRG Timing

Specification is identical to that from (A)-Grade except Ta=-40 to +110°C.

3.7.3 Key Return Timing

Specification is identical to that from (A)-Grade except Ta=-40 to +110°C.

3.7.4 Timer Timing

Specification is identical to that from (A)-Grade except Ta=-40 to +110°C.

3.7.5 CSI Timing

Specification is identical to that from (A)-Grade except Ta=-40 to +110°C.

3.7.6 UART Timing

Specification is identical to that from (A)-Grade except Ta=-40 to +110°C.

3.7.7 IIC Timing

Specification is identical to that from (A)-Grade except Ta=-40 to +110°C.

3.7.8 CAN Timing

Specification is identical to that from (A)-Grade except Ta=-40 to +110°C.

3.8 A/D Converter

Specification is identical to that from (A)-Grade except Ta=-40 to +110°C.

3.9 POC

Specification is identical to that from (A)-Grade except Ta=-40 to +110°C.

3.10 LVI

Specification is identical to that from (A)-Grade except Ta=-40 to +110°C.

3.11 RAM Retention Flag

Specification is identical to that from (A)-Grade except Ta=-40 to +110°C.

3.12 Data Retention Characteristics

Specification is identical to that from (A)-Grade except Ta=-40 to +110°C.

3.13 Flash Memory Programming Characteristics

(a) Basic Characteristics

(C=4.7μF, VDD = EVDD, AVREF0 = 3.5 to 5.5V, VSS = EVSS = AVSS = 0V)

Parameter	Symbol	Conditions	MIN.	TYP.	MAX.	Unit
Operation frequency	fCPU		4		32	MHz
Supply voltage	VDD		3.3		5.5	V
Number of rewrites	CWRT1	Code Flash	1000			count
	CWRT2	Data Flash	10000			
High level input voltage	VIH	FLMD0	0.8EVDD		EVDD	V
Low level input voltage	VIL	FLMD0	EVSS		0.2EVDD	V
Programming temperature	tPRG		-40		+110	°C
Data retention		Code Flash			15 ^{Note1}	year
		Data Flash			5 ^{Note2}	

- Notes:** 1. Under the condition of CWRT1
2. Under the condition of CWRT2

Remark: The initial write when the product is shipped, any erase → write set of operations, or any programming operation is counted as one rewrite.

Example: P: Program(write) E: Erase

Product is shipped → P → E → P → E → P : Rewrite count: 3

Product is shipped → E → P → E → P → E → P : Rewrite count: 3

(b) Serial Writing Operation Characteristics

Specification is identical to that from (A)-Grade except Ta=-40 to +110°C.

4. Electrical Specifications of (A2)-Grade

This product has to be used only under the conditions of VDD=EVDD. Operation is not ensured at the time of using this product except this condition.

4.1 Absolute Maximum Ratings

Specification is identical to that from (A1)-Grade except

- Operating ambient temperature Ta = -40 to +125°C
- **Note2:** AVREF0 IOH/IOL current is including ADC0 max. current IAREF0.

4.2 Capacities

Specification is identical to that from (A)-Grade except Ta=-40 to +125°C.

4.3 Operating condition

(Ta = -40 to +125°C, C=4.7μF, VDD = EVDD = 3.3 to 5.5V, AVREF0 = 3.3 to 5.5V, VSS = EVSS = AVSS = 0V)

Internal System clock frequency (f _{VBLK})	Supply voltage	Operating Condition
4.0 ≤ f _{xx} ≤ 24MHz Note1	4.0V ≤ VDD ≤ 5.5V ^{Note2}	Operation of functions is usable under following conditions: <ul style="list-style-type: none"> Peripheral clock frequency <ul style="list-style-type: none"> f_{XP1} ≤ f_{XX} f_{XP2} ≤ f_{XX} AC characteristics: <ul style="list-style-type: none"> Refer to chapter '4.7 AC Characteristics' for details.
	3.5V ≤ VDD < 4.0V ^{Note2}	Operation of functions is usable under following conditions: <ul style="list-style-type: none"> Peripheral clock frequency <ul style="list-style-type: none"> f_{XP1} ≤ 20MHz f_{XP2} ≤ 20MHz AC characteristics: <ul style="list-style-type: none"> Refer to chapter '4.7 AC Characteristics' for details.
	3.3V ≤ VDD < 3.5V ^{Note2}	Only operation of the following functions is assured: <ul style="list-style-type: none"> CPU Flash (include programming) RAM IO Buffer Port WT WDT INT CLM POC LVI
	3.3V ≤ AVREF0 ≤ 5.5V	<ul style="list-style-type: none"> A/D Converter <ul style="list-style-type: none"> Refer to chapter '4.8 A/D Converter' for details. stop ADC for AVREF0 < 4.0V (ADA0CE bit =0)
12.5kHz ≤ f _{XT} ≤ 27.5kHz ^{Note3} (RC)	3.3V ≤ VDD < 5.5V ^{Note2}	-
f _{RL} (240kHz Internal-OSC)	3.3V ≤ VDD < 5.5V ^{Note2}	-

- Notes:**
- For using SSCG please refer to '4.5.5 SSCG Characteristics' for details
 - VDD = EVDD
 - RC Oscillation frequency is min. 25kHz max. 55kHz. This clock is divided by 2 internally.

4.4 Voltage Regulator Characteristics

Specification is identical to that from (A)-Grade except Ta=-40 to +125°C.

4.5 Clock Generator Circuit

4.5.1 Main System Clock Oscillation Circuit Characteristics

Specification is identical to that from (A)-Grade except Ta=-40 to +125°C.

4.5.2 Sub System Clock Oscillation Circuit Characteristics

Specification is identical to that from (A1)-Grade except Ta=-40 to +125°C.

4.5.3 Internal-OSC Characteristics

Specification is identical to that from (A)-Grade except Ta=-40 to +125°C.

4.5.4 PLL Characteristics

(Ta = -40 to +125°C, C=4.7uF, VDD = EVDD = 3.3 to 5.5V, AVREF0 = 3.3 to 5.5V, VSS = EVSS = AVSS = 0V)

Parameter	Symbol	Conditions	MIN.	TYP.	MAX.	Unit
Input frequency	fx		4		16	MHz
	f _{PLLI}	Note	3		6	MHz
Output frequency	fx	≤256KB product	12		24	MHz
Lock time	t _{PLL}	After VDD reaches voltage range min. 3.3V			800	μs
Output period jitter Note2	tpj	Peak to peak			2.0	ns

- Notes:**
- The input of the PLL (f_{PLLI}) can be set to f_x, f_x/2, or f_x/4. The divider is set through an option byte in the code flash memory.
 - Not tested in production.

4.5.5 SSCG Characteristics

(Ta = -40 to +125°C, C=4.7uF, VDD = EVDD = 3.3 to 5.5V, AVREF0 = 3.3 to 5.5V, VSS = EVSS = AVSS = 0V)

Parameter	Symbol	Conditions	MIN.	TYP.	MAX.	Unit
Input frequency	fx		4		16	MHz
Output frequency	fx	≤256KB product	12		24	MHz
Lock time	t _{SSCG}	After VDD reaches voltage range min. 3.3V			1000	μs

Remark: The SSCG MAX output frequency indicates the case without modulation. If modulation is enabled the average SSCG frequency has to be set lower. The maximum achievable average operating frequency with modulation is as follows:

SSCG input clock divider selector SFC1[6:4]	Percent modulation		Maximum average operating frequency		Unit
	TYP	MAX	≤256KB product		
000B	± 0.5%	± 2.0%	23.5		MHz
001B	± 1.0%	± 2.5%	23.4		
010B	± 2.0%	± 4.0%	23.0		
011B	± 3.0%	± 6.0%	22.6		
100B	± 4.0%	± 8.0%	22.1		
101B	± 5.0%	± 10.0%	21.6		

4.6 DC Characteristics

4.6.1 Input/Output Level

Specification is identical to that from (A1)-Grade except

- Ta = -40 to +125°C.
- **Note 2:** Total IOH/IOL max is 20mA/-20mA for the power supply lines EVDD.
Total IOH/IOL max is 3mA/-3mA for the power supply line AVREF0.
AVREF0 IOH/IOL current is excluding ADC0 current IAREF0.
If ADC0 is not used total IOH/IOL max is 10mA/-10mA for the power supply line AVREF0.

4.6.2 PIN leakage current

(Ta = -40 to +125°C, C=4.7uF, VDD = EVDD = 3.3 to 5.5V, AVREF0 = 3.3 to 5.5V, VSS = EVSS = AVSS = 0V)

Parameter	Symbol	Conditions	MIN.	TYP.	MAX.	Unit
High level input leakage current	ILIH1	VI=VDD	Analog pins		0.5	uA
			Other pins ^{Note1}		1.0	
Low level input leakage current	ILIL1	VI=0V	Analog pins		-0.5	
			Other pins ^{Note1}		-1.0	
High level output leakage current	ILOH1	VO=VDD	Analog pins		0.5	
			Other pins		1.0	
Low level output leakage current	ILOL1	VO=0V	Analog pins		-0.5	
			Other pins		-1.0	

- Notes: 1.** The input leakage current of FLMD0 is as follows:
High level input leakage current: 5.0uA
Low level input leakage current: -5.0uA

4.6.3 Power supply current (A2-grade)

4.6.3.1 FE3 128KB μ PD70F3370A, FE3 256KB μ PD70F3371

(a) Absolute values

(Ta = -40 to +125°C, C=4.7 μ F,

VDD = EVDD = 3.3 to 5.5V, AVREF0 = 3.3 to 5.5V, VSS = EVSS = AVSS = 0V^{Note1)})

Mode	Symbol	Condition			TYP.	MAX.	Unit		
Operating mode Note2,8	IDD1	All peripherals running	Peripheral: f _{xx} PRSI option: 0	PLL: ON 12MHz ≤ f _{xx} ≤ 24MHz	f _{xx} =20MHz f _x =5MHz	27	37	mA	
				PLL: OFF 4MHz ≤ f _{xx} ≤ 16MHz	f _{xx} =8MHz 8MHz Internal-OSC ^{Note3}	13	20	mA	
					f _{xx} =16MHz f _x =16MHz	21	30	mA	
		All peripherals stopped	Peripheral: f _{xx} PRSI option: 0	PLL: ON 12MHz ≤ f _{xx} ≤ 24MHz	f _{xx} =20MHz f _x =5MHz	22		mA	
				PLL: OFF 4MHz ≤ f _{xx} ≤ 16MHz	f _{xx} =8MHz 8MHz Internal-OSC ^{Note3}	12		mA	
					f _{xx} =16MHz f _x =16MHz	19		mA	
HALT mode Note8	IDD2	All peripherals running	Peripheral: f _{xx} PRSI option: 0	PLL: ON 12MHz ≤ f _{xx} ≤ 24MHz	f _{xx} =20MHz f _x =5MHz	16	23	mA	
				PLL: OFF 4MHz ≤ f _{xx} ≤ 16MHz	f _{xx} =8MHz 8MHz Internal-OSC ^{Note3}	8	12	mA	
					f _{xx} =16MHz f _x =16MHz	13	20	mA	
		All peripherals stopped	Peripheral: f _{xx} PRSI option: 0	PLL: ON 12MHz ≤ f _{xx} ≤ 24MHz	f _{xx} =20MHz f _x =5MHz	12		mA	
				PLL: OFF 4MHz ≤ f _{xx} ≤ 16MHz	f _{xx} =8MHz 8MHz Internal-OSC ^{Note3}	5		mA	
					f _{xx} =16MHz f _x =16MHz	9		mA	
IDLE1 mode	IDD3	Peripheral (TAA, UARTD) running		PLL: OFF 4MHz ≤ f _{xx} ≤ 16MHz Note7	f _{xx} =5MHz f _x =5MHz	1.4	2.8	mA	
					f _{xx} =12MHz f _x =12MHz	2.0	3.7	mA	
					f _{xx} =16MHz f _x =16MHz	2.4	4.2	mA	
				f _{xx} =8MHz, 8MHz Internal-OSC ^{Note3}	1.5	2.9	mA		
		All peripherals stopped		PLL: OFF 4MHz ≤ f _{xx} ≤ 16MHz Note7		f _{xx} =5MHz f _x =5MHz	1.2		mA
						f _{xx} =12MHz f _x =12MHz	1.4		mA
						f _{xx} =16MHz f _x =16MHz	1.6		mA
						f _{xx} =8MHz, 8MHz Internal-OSC ^{Note3}	1.1		mA

Mode	Symbol	Condition	TYP.	MAX.	Unit	
IDLE2 mode	IDD4	PLL: OFF 4MHz≤f _{xx} ≤16MHz Note7	f _{xx} =5MHz f _x =5MHz	0.4	1.1	mA
			f _{xx} =12MHz f _x =12MHz	0.7	1.5	mA
			f _{xx} =16MHz f _x =16MHz	0.8	1.7	mA
		f _{xx} =8MHz, 8MHz Internal-OSC Note3	0.2	1.0	mA	
SUB operating mode Note5	IDD5	RC resonator (fxt=20kHz) Note6	80	850	μA	
		240 kHz Internal-OSC (SubOSC stopped)	220	1450	μA	
SubIDLE mode Note3,5	IDD6	RC resonator (fxt=20kHz) Note6	40	670	μA	
		240kHz Internal-OSC (SubOSC stopped)	25	630	μA	
STOP mode Note3,4	IDD7	POC stop	240kHz Internal-OSC stop	7.5	530	μA
			240kHz Internal-OSC working	15.5	545	μA
		POC work	240kHz Internal-OSC stop	10.5	535	μA
			240kHz Internal-OSC working	18.5	550	μA

(b) Calculation formulas

(Ta = -40 to +125°C, C=4.7uF,

VDD = EVDD = 3.3 to 5.5V, AVREF0 = 3.3 to 5.5V, VSS = EVSS = AVSS = 0V^{Note1)})

Mode	Symbol	Condition		TYP. ^{Note9}	MAX. ^{Note9}	Unit	
Operating mode Note2,8	IDD1	All peripherals running	Peripheral: f _{xx} PRSI option: 0	PLL: ON 12MHz ≤ f _{xx} ≤ 24MHz	0.98·f _{xx} +7.1	1.18·f _{xx} +13.6	mA
			Peripheral: f _{xx} /2 PRSI option: 1	PLL: OFF 4MHz ≤ f _{xx} ≤ 16MHz	0.98·f _{xx} +5.5	1.18·f _{xx} +10.6	mA
				PLL: ON 12MHz ≤ f _{xx} ≤ 24MHz	0.90·f _{xx} +6.0	1.08·f _{xx} +12.2	mA
		All peripherals stopped	Peripheral: f _{xx} PRSI option: 0	PLL: ON 12MHz ≤ f _{xx} ≤ 24MHz	0.81·f _{xx} +6.2		mA
				PLL: OFF 4MHz ≤ f _{xx} ≤ 16MHz	0.83·f _{xx} +5.7		mA
			Peripheral: f _{xx} /2 PRSI option: 1	PLL: ON 12MHz ≤ f _{xx} ≤ 24MHz	0.79·f _{xx} +6.2		mA
HALT mode Note8	IDD2	All peripherals running	Peripheral: f _{xx} PRSI option: 0	PLL: ON 16MHz ≤ f _{xx} ≤ 24MHz	0.67·f _{xx} +3.0	0.90·f _{xx} +5.4	mA
				PLL: OFF 4MHz ≤ f _{xx} ≤ 16MHz	0.70·f _{xx} +1.9	1.00·f _{xx} +4.0	mA
			Peripheral: f _{xx} /2 PRSI option: 1	PLL: ON 16MHz ≤ f _{xx} ≤ 24MHz	0.55·f _{xx} +2.8	0.64·f _{xx} +7.0	mA
		All peripherals stopped	Peripheral: f _{xx} PRSI option: 0	PLL: ON 16MHz ≤ f _{xx} ≤ 24MHz	0.46·f _{xx} +2.8		mA
				PLL: OFF 4MHz ≤ f _{xx} ≤ 16MHz	0.44·f _{xx} +1.6		mA
			Peripheral: f _{xx} /2 PRSI option: 1	PLL: ON 16MHz ≤ f _{xx} ≤ 24MHz	0.46·f _{xx} +1.8		mA
IDLE1 mode	IDD3	Peripheral (TAA, UARTD) running	PLL: OFF 4MHz ≤ f _{xx} ≤ 16MHz	0.092·f _{xx} +0.90	0.128·f _{xx} + 2.12	mA	
		All peripherals stopped	Note7	0.035·f _{xx} +1.01		mA	
IDLE2 mode	IDD4	PLL: OFF 4MHz ≤ f _{xx} ≤ 16MHz ^{Note7}		0.037·f _{xx} +0.21	0.049·f _{xx} + 0.88	mA	

- Notes:**
- VDD and EVDD total current. (Ports are stopped).
AVREF0 current, port buffer current (including a current flowing in the on-chip pull-up/pull-down resistor) are not included.
 - The code flash and the data flash are in read mode.
When the device is in programming mode (Self-programming mode or data flash programming mode), the current value (MAX. value) adds by the following value:
 - Self-programming mode:
 - + In case of PLL OFF: 7-(0.33·f_{xx}+0.1) [mA]
 - + In case of PLL ON: 7-(0.18·f_{xx}+3.0) [mA]
 - Data flash programming mode:
 - + 7-(0.18·f_{xx}/4+3.0) [mA]
 - Main OSC is stopped.
 - Do not use SubOSC.
 - POC is working. 240kHz Internal-OSC is working. 8MHz Internal-OSC is stopped.
 - RC Oscillation frequency is typ.40kHz. This clock is divided by 2 internally.
 - 8MHz Internal-OSC is stopped
 - When the SSCG is running, the current value adds typ +2.5mA, max +4mA.
 - The formulas are for reference only. Not all possible values for f_{xx} are tested in the outgoing device inspection.

4.7 AC Characteristics

AC test Input measurement points (VDD, AVREF0, EVDD)

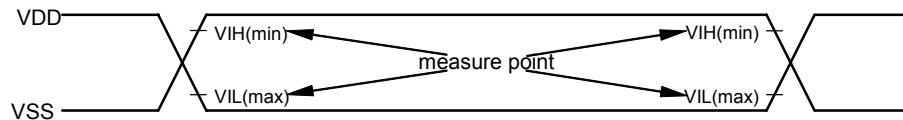

AC test output measurement points

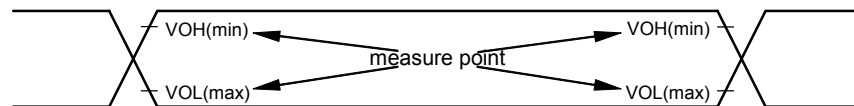

Load conditions

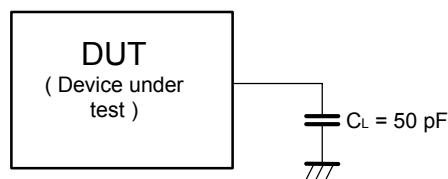

Caution: If the load capacitance exceeds 50pF due to the circuit configuration, reduce the load capacitance of the device to 50pF or less by inserting a buffer or by some other means.

4.7.1 CLKOUT Output Timing

Specification is identical to that from (A)-Grade except $T_a = -40$ to $+125^\circ\text{C}$.

4.7.2 RESET, Interrupt, ADTRG Timing

Specification is identical to that from (A)-Grade except $T_a = -40$ to $+125^\circ\text{C}$.

4.7.3 Key Return Timing

Specification is identical to that from (A)-Grade except $T_a = -40$ to $+125^\circ\text{C}$.

4.7.4 Timer Timing

Specification is identical to that from (A)-Grade except $T_a = -40$ to $+125^\circ\text{C}$.

4.7.5 CSI Timing

Specification is identical to that from (A)-Grade except $T_a = -40$ to $+125^\circ\text{C}$.

4.7.6 UART Timing

Specification is identical to that from (A)-Grade except $T_a = -40$ to $+125^\circ\text{C}$.

4.7.7 IIC Timing

Specification is identical to that from (A)-Grade except $T_a = -40$ to $+125^\circ\text{C}$.

4.7.8 CAN Timing

Specification is identical to that from (A)-Grade except $T_a = -40$ to $+125^\circ\text{C}$.

4.8 A/D Converter

(Ta = -40 to +125°C, C=4.7uF, VDD = EVDD = 3.5 to 5.5V, AVREF0 = 4.0 to 5.5V, VSS = EVSS = AVSS = 0V)

Parameter	Symbol	Conditions	MIN.	TYP.	MAX.	Unit
Resolution					10	bit
Overall error ^{Note1}		4.0V≤AVREF0<5.5V		±0.15	±0.35	%FSR
Conversion time	tCONV		3.10		16	μs
Stabilization time	tSTA	After ADA0PS bit = 0 -> 1	2			μs
Recovery time for power down mode	tDPU		1			μs
Zero-scale error ^{Note1}	ZSE				±0.35	%FSR
Full-scale error ^{Note1}	FSE				±0.35	%FSR
Integral non-linearity error ^{Note2}	INL				±2.5	LSB
Differential non-linearity error ^{Note2}	DNL				±1.5	LSB
Analog input voltage	VIAN		AVSS		AVREF0	V
Analog input equivalent circuit capacitance ^{Note3,4}	CINA				6.19	pF
Analog input equivalent circuit resistance ^{Note3}	RINA				2.55	kΩ
AVREF0 current	IAREF0	A/D operating		4	7	mA
		A/D operation stop		1	10	uA
Conversion result when using Diagnostic function		AVREF0 conversion	3FC		3FF	HEX
		AVSS conversion	000		003	HEX

- Notes:**
1. Overall error excluding quantization error (±0.05%FSE). It is indicated as a ratio to the full-scale value.
 2. Excluding quantization error (±1/2 LSB)
 3. Not tested in production.
 4. Does not include input/output capacitance CIO

4.9 POC

Specification is identical to that from (A)-Grade except Ta=-40 to +125°C.

4.10 LVI

Specification is identical to that from (A)-Grade except Ta=-40 to +125°C.

4.11 RAM Retention Flag

Specification is identical to that from (A)-Grade except Ta=-40 to +125°C.

4.12 Data Retention Characteristics

Specification is identical to that from (A)-Grade except Ta=-40 to +125°C.

4.13 Flash Memory Programming Characteristics

(a) Basic Characteristics

(C=4.7 μ F, VDD = EVDD, AVREF0 = 3.5 to 5.5V, VSS = EVSS = AVSS = 0V)

Parameter	Symbol	Conditions	MIN.	TYP.	MAX.	Unit
Operation frequency	fCPU		4		32	MHz
Supply voltage	VDD		3.3		5.5	V
Number of rewrites	CWRT1	Code Flash	1000			count
	CWRT2	Data Flash		10000		
High level input voltage	VIH	FLMD0	0.8EVDD		EVDD	V
Low level input voltage	VIL	FLMD0	EVSS		0.2EVDD	V
Programming temperature	tPRG		-40		+125	°C
Data retention		Code Flash			15 ^{Not1}	year
		Data Flash			5 ^{Note2}	

- Notes:** 1. Under the condition of CWRT1
2. Under the condition of CWRT2

Remark: The initial write when the product is shipped, any erase → write set of operations, or any programming operation is counted as one rewrite.

Example: P: Program(write) E: Erase

Product is shipped → P → E → P → E → P : Rewrite count: 3

Product is shipped → E → P → E → P → E → P : Rewrite count: 3

(b) Serial Writing Operation Characteristics

Specification is identical to that from (A)-Grade except Ta=-40 to +125°C.

5. Package

5.1 Package Dimension

64-PIN PLASTIC LQFP(FINE PITCH)(10x10)

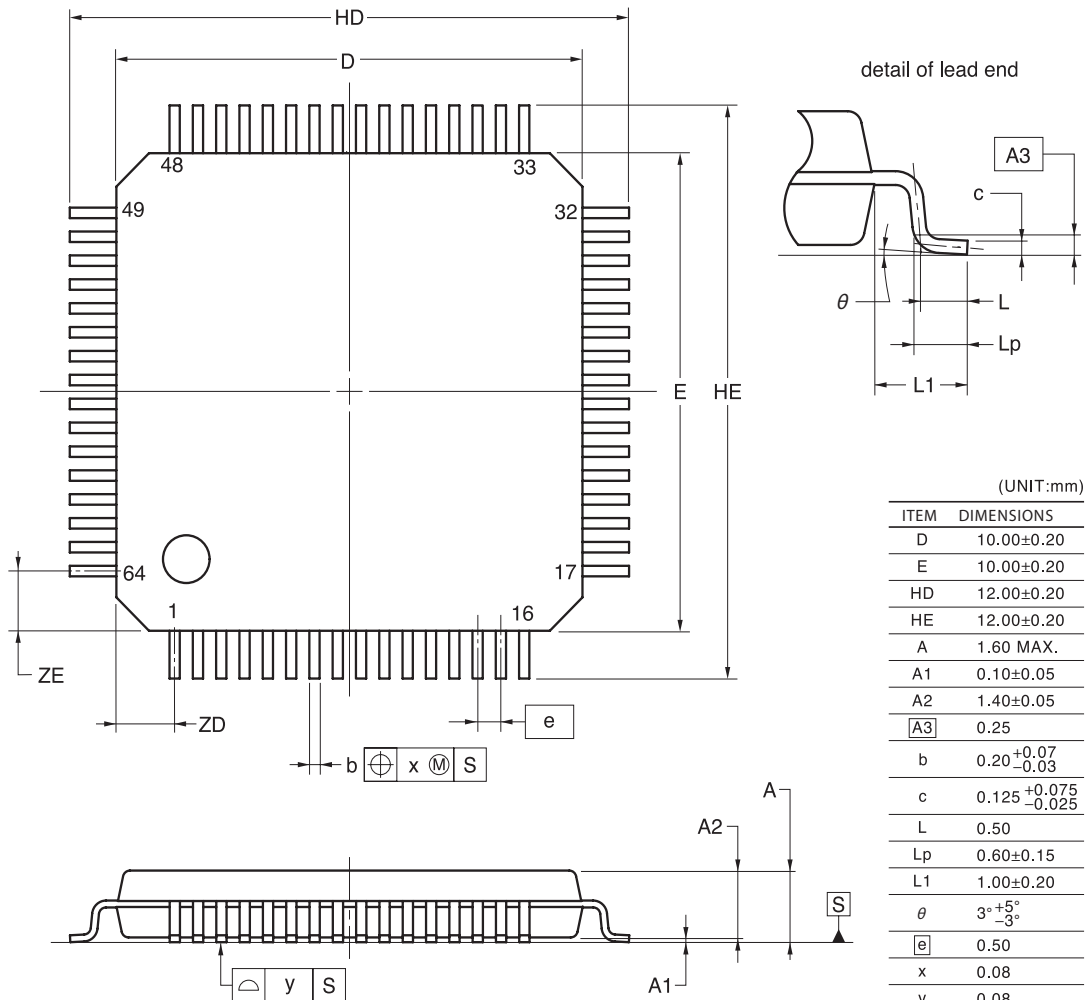

NOTE
Each lead centerline is located within 0.08 mm of its true position at maximum material condition.

5.2 Product Marking

5.2.1 Marking of pin 1 at a QFP (Quad Flat Package)

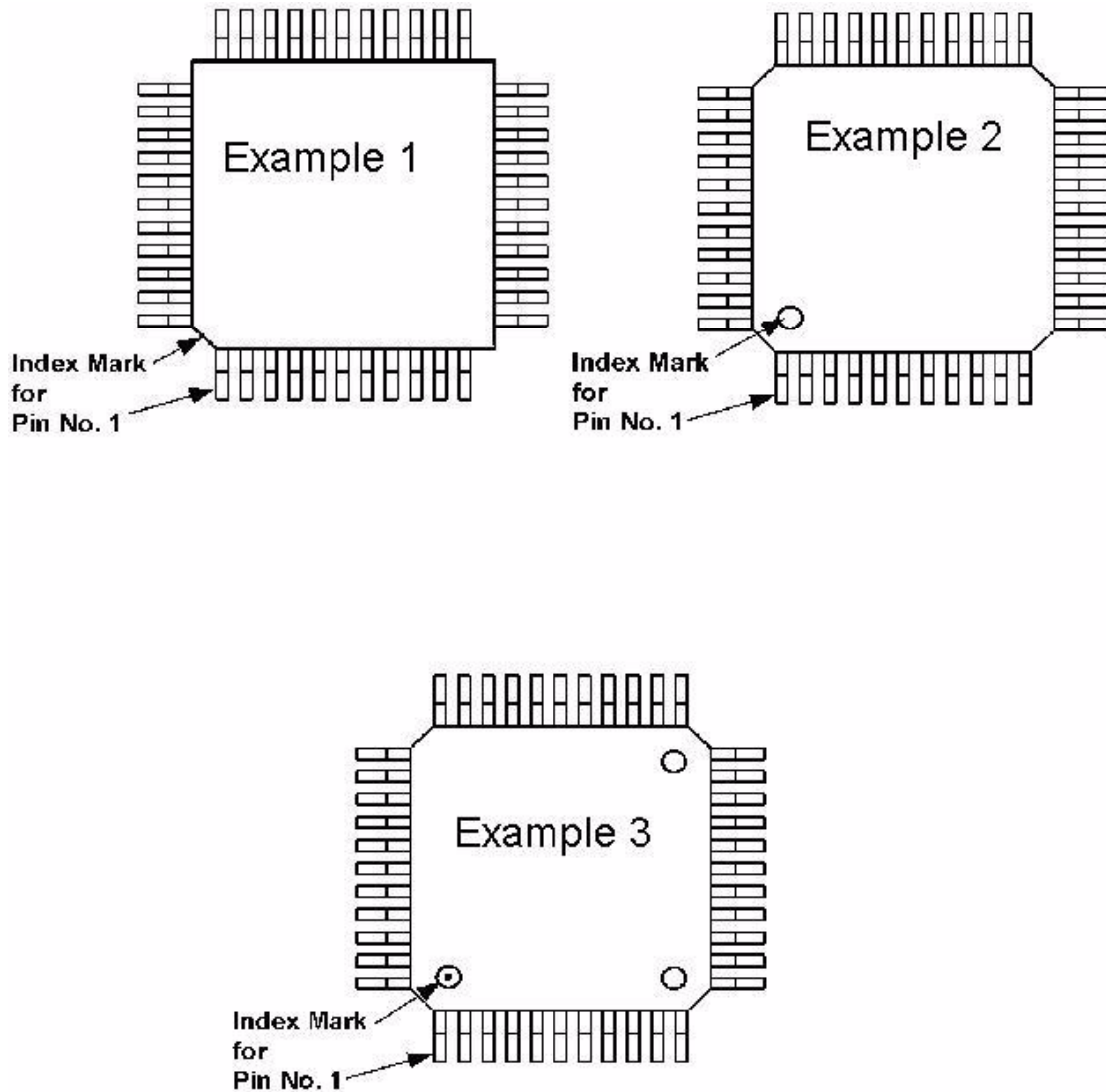

Example 1: The index mark for pin 1 is the beveled edge of the package

Example 2: The index mark for pin 1 is a round notch at one of the 4 edges. In this case, the shape of all edges is identical (usually beveled).

Example 3: For production reasons, two or more similar notches may be located at the top of the package. In such a case the index marker for pin 1 is a round notch with an additional mark in it.

Note: RoHS compliant devices have an additional dot at the top side. Do not mix it up with the marking for pin 1. For details see 5.2.2 "Identification of Lead-Free Products" on page 53.

5.2.2 Identification of Lead-Free Products

Lead-Free products are marked with a dot "•". The marking methods are the paint or the laser (It doesn't sink in). The shape of lead-free marks is a circle.

Example:

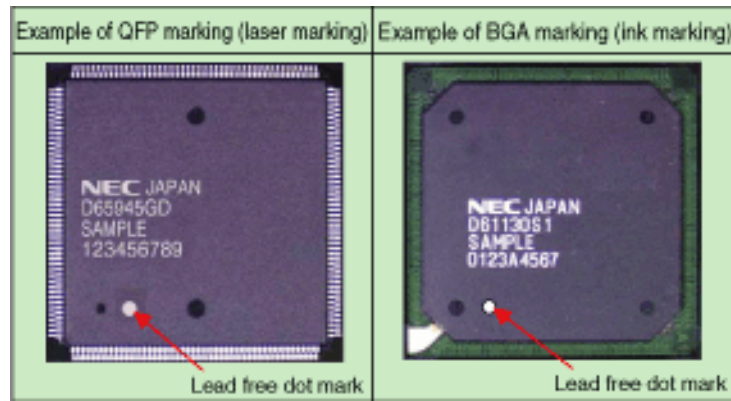

6. Change History

The following revision list shows all major changes of the different datasheet versions.

Version	Chapter	Comment
V1.0		Initial release
V1.1	2.13	Removed 'Target Specification' for (A)- and (A1)-Grade Devices in the Flash Programming specifications.
	3.13	
	2.8 4.8	Remove Caution (Described in User's Manual)
V1.2		Changed document status from 'Preliminary Datasheet' to 'Datasheet'.
	4.12	Removed 'Target Specification' for (A2)-Grade Devices in the Flash Programming specifications.

Facsimile Message

From:

Name

Company

Tel.

FAX

Address

Although NEC has taken all possible steps to ensure that the documentation supplied to our customers is complete, bug free and up-to-date, we readily accept that errors may occur. Despite all the care and precautions we've taken, you may encounter problems in the documentation. Please complete this form whenever you'd like to report errors or suggest improvements to us.

Thank you for your kind support.

North America

NEC Electronics America Inc.
Corporate Communications Dept.
Fax: 1-800-729-9288
1-408-588-6130

Hong Kong, Philippines, Oceania

NEC Electronics Hong Kong Ltd.
Fax: +852-2886-9022/9044

Asian Nations except Philippines

NEC Electronics Singapore Pte. Ltd.
Fax: +65-6250-3583

Europe

NEC Electronics (Europe) GmbH
Market Communication Dept.
Fax: +49(0)-211-6503-1344

Korea

NEC Electronics Hong Kong Ltd.
Seoul Branch
Fax: 02-528-4411

Japan

NEC Semiconductor Technical Hotline
Fax: +81- 44-435-9608

Taiwan

NEC Electronics Taiwan Ltd.
Fax: 02-2719-5951

I would like to report the following error/make the following suggestion:

Document title: _____

Document number: _____ Page number: _____



If possible, please fax the referenced page or drawing.

Document Rating	Excellent	Good	Acceptable	Poor
Clarity	<input type="checkbox"/>	<input type="checkbox"/>	<input type="checkbox"/>	<input type="checkbox"/>
Technical Accuracy	<input type="checkbox"/>	<input type="checkbox"/>	<input type="checkbox"/>	<input type="checkbox"/>
Organization	<input type="checkbox"/>	<input type="checkbox"/>	<input type="checkbox"/>	<input type="checkbox"/>



[MEMO]

Looking for pricing, stock, or lifecycle information?

Click below to explore more details on WIN SOURCE:

-  [View UPD70F3378M2GJA-GAE-AX on WIN SOURCE](#)
-  [Renesas Electronics America Information](#)

Optimize Your Supply Chain with WIN SOURCE Solutions

-  Global Sourcing Solution
-  Obsolete Management
-  Cost Control Management
-  Shortage Management
-  Alternative Solution
-  Excess Inventory Management