

Description

ZSC31050 is a CMOS integrated circuit for highly accurate amplification and sensor-specific correction of bridge sensor and temperature sensor signals. The device provides digital compensation of sensor offset, sensitivity, temperature drift, and non-linearity via a 16-bit RISC microcontroller running a polynomial correction algorithm.

The ZSC31050 accommodates virtually any bridge sensor type (e.g., piezo-resistive, ceramic thick-film, or steel membrane based). In addition, it can interface to a separate temperature sensor. The bi-directional digital interfaces (I²C, SPI, and ZACwire™) can be used for a simple PC-controlled one-pass calibration procedure to program a set of calibration coefficients into an on-chip EEPROM. A specific sensor and a ZSC31050 can be mated digitally: fast, precise, and without the cost overhead associated with trimming by external devices or laser. The ZACwire™ interface enables an end-of-line calibration of the sensor module.

Typical applications for the ZSC31050 include industrial, medical, and consumer products. It is specifically engineered for most resistive bridge sensors; e.g., sensors for measuring pressure, force, torque, acceleration, angle, position, and revolution.

Benefits

- No external trimming components required
- PC-controlled configuration and calibration via digital bus interface – simple, low cost
- High accuracy ($\pm 0.1\%$ FSO @ -25 to 85°C ; $\pm 0.25\%$ FSO @ -40 to 125°C)*

Available Support

- Evaluation kit available
- Support for industrial mass calibration available
- Quick circuit customization possible for large production volumes

Features

- Digital compensation of sensor offset, sensitivity, temperature drift, and nonlinearity
- Accommodates nearly all resistive bridge sensor types (signal spans from 1mV/V up to 275mV/V)
- Digital one-pass calibration: quick and precise
- Selectable compensation temperature source: bridge, thermistor, or internal or external diode
- Output options: voltage (0 to 5V), current (4 to 20mA), PWM, I²C, SPI, ZACwire™ (one-wire interface), alarm
- Adjustable output resolution (up to 15 bits) versus sampling rate (up to 3.9kHz)
- Current consumption: 2.5mA (typical)
- Selectable bridge excitation: ratiometric voltage, constant voltage, or constant current
- Input channel for separate temperature sensor
- Sensor connection and common mode check (sensor aging detection)
- AEC-Q100 qualification (temperature grade 0)

Physical Characteristics

- Operation temperature -40°C to $+125^\circ\text{C}$ (-40°C to $+150^\circ\text{C}$ de-rated, depending on product version)
- Supply voltage: 2.7V to 5.5V; with external JFET: 5V to 48 V
- Available in 16-SSOP package or as die

Basic Circuit Diagram

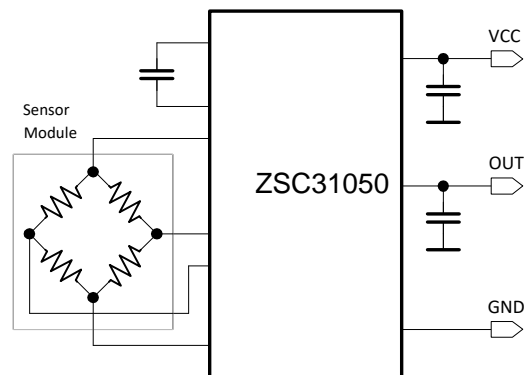

* Digital output signal.

Block Diagram

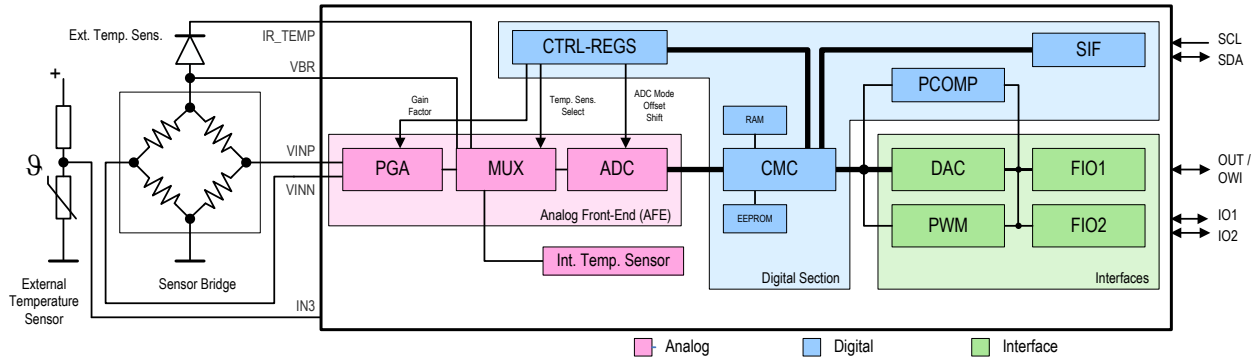

Typical Applications:

Consumer Goods

- Weight scales
- Flow meters
- Strain gauges
- Load meters
- HVAC

Industrial Applications

- 4-20mA transmitters
- Intelligent sensor networks
- Process automation
- Factory automation

Portable Devices

- Altimeters
- Blood pressure monitors

Automotive Sensors *

- Oil pressure
- Temperature sensing
- Strain gauges

* AEC-Q100 qualified

Contents

1.	Electrical Characteristics	5
1.1	Absolute Maximum Ratings	5
1.2	Operating Conditions	5
1.3	Inherent Characteristics	7
1.3.1	Cycle Rate versus ADC Resolution	8
1.3.2	PWM Frequency	8
1.4	Electrical Parameters	9
1.4.1	Supply/Regulation	9
1.4.2	Analog Front End	9
1.4.3	DAC and Analog Output (OUT Pin)	9
1.4.4	PWM Output (OUT Pin, IO1 Pin)	9
1.4.5	Temperature Sensors (IR_TEMP Pin)	9
1.4.6	Digital Outputs (IO1, IO2, OUT Pins in Digital Mode)	10
1.4.7	System Response	10
1.5	Interface Characteristics	11
1.5.1	Multiprotocol Serial Interfaces (I ² C, SPI)	11
1.5.2	One-Wire Serial Interface (ZACwire™)	11
2.	Circuit Description	12
2.1	Signal Flow	12
2.2	Application Modes	13
2.3	Analog Front-End (AFE)	14
2.3.1	Programmable Gain Amplifier (PGA)	14
2.3.2	Extended Zero Point Compensation (XZC)	14
2.3.3	Measurement Cycle Performed by Multiplexer	16
2.3.4	Analog-to-Digital Converter	16
2.4	System Control	18
2.5	Output Stage	18
2.5.1	Analog Output	20
2.5.2	Comparator Module (ALARM Output)	20
2.5.3	Serial Digital Interface	20
2.6	Voltage Regulator	21
2.7	Watchdog and Error Detection	21
3.	Application Circuit Examples	22
4.	ESD/Latch-Up-Protection	23
5.	Pin Configuration and Package	24
6.	Reliability	25
7.	Customization	25
8.	Ordering Information	26
9.	Related Documents	26

10. Glossary	27
11. Revision History.....	28

List of Figures

Figure 1. Block Diagram of the ZSC31050	12
Figure 2. Measurement Cycle ZSC31050.....	16
Figure 3. Application Example 1	22
Figure 4. Application Example 2.....	22
Figure 5. Application Example 3.....	22
Figure 6. Application Example 4.....	22
Figure 7. Application Example 5.....	23
Figure 8. Pin Configuration	25

List of Tables

Table 1. Adjustable Gains, Resulting Sensor Signal Spans, and Common Mode Ranges	14
Table 2. Extended Zero Point Compensation (XZC) Range.....	15
Table 3. Output Resolution versus Sample Rate.....	17
Table 4. Output Configurations Overview.....	18
Table 5. Analog Output Configuration	20
Table 6. Pin Configuration	24

1. Electrical Characteristics

1.1 Absolute Maximum Ratings

The absolute maximum ratings are stress ratings only. The ZSC31050 might not function or be operable above the recommended operating conditions. Stresses exceeding the absolute maximum ratings might also damage the device. In addition, extended exposure to stresses above the recommended operating conditions might affect device reliability. Renesas does not recommend designing to the “Absolute Maximum Ratings.”

No.	Parameter	Symbol	Conditions	Min	Max	Unit
1.1.1	Digital supply voltage	VDD _{MAX}	To VSS	-0.3	6.5	V DC
1.1.2	Analog supply voltage	VDDA _{MAX}	To VSS	-0.3	6.5	V DC
1.1.3	Voltage at all analog and digital I/O pins except FBP, SDA, SCL (see 1.1.4, 1.1.5, and 1.1.6)	V _{A_I/O} , V _{D_I/O}		-0.3	VDDA+0.3	V DC
1.1.4	Voltage at FBP pin	V _{FBP_MAX}	4mA to 20mA – Interface	-1.2	VDDA+0.3	V DC
1.1.5	Voltage at SDA pin	V _{SDA_MAX}	I ² C mode only	-0.3	5.5	V DC
1.1.6	Voltage at SCL pin	V _{SCL_MAX}	I ² C mode only	-0.3	5.5	V DC
1.1.7	Storage temperature	T _{STG}		-45	150	°C

1.2 Operating Conditions

Unless otherwise noted, voltages are relative to VSS and analog-to-digital conversion = 2nd order, resolution = 13 bits, gain ≥ 210, f_{clk} ≤ 2.25MHz.

For specifications marked with an asterisk (*), there is no measurement in mass production—the parameter is guaranteed by design and/or quality observations.

Note: See important notes at the end of the table.

No.	Parameter	Symbol	Conditions	Min	Typical	Max	Unit
1.2.1	1.2.1.1 TQE ambient temperature range for part numbers ZSC31050xExx	T _{AMB_TQE}	Operation life time < 1000h @ 125°C to 150°C	-40		150	°C
	1.2.1.2 TQA ambient temperature range for part numbers ZSC31050xAxx	T _{AMB_TQA}		-40		125	°C
	1.2.1.3 TQI ambient temperature range for part numbers ZSC31050xIxx	T _{AMB_TQI}		-25		85	°C
1.2.2	Ambient temperature EEPROM programming	T _{AMB_EEP}		-25		85	°C
1.2.3	EEPROM programming cycles					100	
1.2.4	Data retention (EEPROM)		Average temp. < 85°C	15			years

No.	Parameter	Symbol	Conditions	Min	Typical	Max	Unit
1.2.5	Analog supply voltage	VDDA	Ratiometric mode	2.7		5.5	V DC
1.2.6	Analog supply voltage advanced performance	VDDA _{ADV}	Ratiometric mode	4.5		5.5	V DC
1.2.7	Digital supply voltage	VDD	Externally powered			1.05	VDDA
				2.7			V DC
1.2.8	External supply voltage	V _{SUPP}	Voltage Regulator Mode with external JFET ^[a]	VDDA + 2V			V DC
1.2.9	Common mode input range ^[b]	V _{IN_CM}	Depends on gain adjust; refer to section 2.3.1	0.21		0.76	V _{ADC_REF}
1.2.10	Input voltage FBP pin	V _{IN_FBP}		-1		VDDA	V DC
1.2.11	Sensor bridge resistance ^[c] (over full temperature range)	R _{BR}		3.0		25.0	kΩ
		R _{BR_CL}	Current loop interface, 4 to 20mA	5.0		25.0	kΩ
1.2.12	Reference resistor for bridge current source *	R _{BR_REF}	Bridge current $I_{BR} = VDDA / (16 \cdot R_{BR_REF})$	0.07			R _{BR}
1.2.13	Stabilization capacitor *	C _{VDDA}	External capacitor between VDDA and VSS	50	100	470	nF
1.2.14	VDD stabilization capacitor*. ^[d]	C _{VDD}	Between VDD and VSS, external	0	100	470	nF
1.2.15	Maximum load capacitance allowed at OUT ^[e]	C _{L_OUT}	Output Voltage Mode			50	nF
1.2.16	Minimum load resistance allowed	R _{L_OUT}	Output Voltage Mode	2			kΩ
1.2.17	Maximum load capacitance allowed at VGATE	C _{L_VGATE}	Total capacitance relative to all potentials			10	nF

[a] Maximum depends on the breakdown voltage of the external JFET; refer to the application recommendations in the *ZSC31050 Application Note—0-10V Output*.

[b] V_{ADC_REF}: reference voltage of the analog-to-digital converter (VBR or VDDA).

[c] No minimum limitation with an external connection between VDDA and VBR.

[d] Lower stabilization capacitors can increase noise level at the output.

[e] If the maximum is used, take into consideration the special requirements of the ZACwire™ interface stated in the *ZSC31050 Functional Description*, section 4.3.

1.3 Inherent Characteristics

For specifications marked with an asterisk (*), there is no measurement in mass production—the parameter is guaranteed by design and/or quality observations.

No.	Parameter	Symbol	Conditions	Min	Typ	Max	Unit
1.3.1	Selectable input span, bridge sensor measurement	V_{IN_SP}	Refer to section 2.3.1.	2		280	mV/V
1.3.2	Analog offset comp range (6 bit setting)			-20		20	Counts
			Maximum bias current [a]	-25		25	Counts
1.3.3	Analog-to-digital conversion (ADC) resolution	r_{ADC}	3-bit setting [b]	9		15	Bits
1.3.4	ADC input range	Range		10		90	%VDDA
1.3.5	Digital-to-analog conversion (DAC) resolution	r_{DAC}	At analog output		11		Bits
1.3.6	PWM resolution	r_{PWM}		9		12	Bits
1.3.7	Bias current for external temperature diodes	I_{TS}		8	18	40	μA
1.3.8	Sensitivity internal temperature diode [c]	ST_{T_SI}	Raw values without conditioning	2800	3200	3600	ppm FS/K
1.3.9	Clock frequency*	f_{CLK}	Guaranteed adjustment range	1	2	4	MHz

[a] Set configuration word ADJREF:BCUR (bits 4-6) to 111 (for details, see the ZSC31050 Functional Description).

[b] 15-bit resolution is not applicable for 1st order ADC and not recommended for sensors with high nonlinearity behavior.

[c] FS = Full scale.

1.3.1 Cycle Rate versus ADC Resolution

The following specifications are guaranteed by design and/or quality observations.

Important note: Combining first-order configuration of the ADC with 15-bit resolution is not allowed.

ADC Order (O _{ADC})	Resolution	Conversion Cycle f _{CYC}
	r _{ADC}	f _{CLK} =2MHz
	[Bit]	[Hz]
1	9	1302
	10	781
	11	434
	12	230
	13	115
	14	59
2	11	3906
	12	3906
	13	1953
	14	1953
	15	977

1.3.2 PWM Frequency

The following specifications are not measured in mass production; they are guaranteed by design and/or quality observations.

PWM Resolution r _{PWM} [Bit]	PWM Frequency in Hz at 2MHz Clock [a]			
	Clock Divider			
	1	0.5	0.25	0.125
9	3906	1953	977	488
10	1953	977	488	244
11	977	488	244	122
12	488	244	122	61

[a] Internal RC oscillator: coarse adjustment to 1MHz, 2MHz, and 4MHz, fine-tuning (-20 to +15)%; external clock is also possible.

1.4 Electrical Parameters

Unless otherwise noted, voltages are relative to VSS and analog-to-digital conversion = 2nd order, resolution = 13 bits, gain ≥210, f_{clk} ≤ 2.25MHz.

Note: See important notes at the end of the table.

No.	Parameter	Symbol	Conditions	Min	Typ	Max	Unit
1.4.1 Supply/Regulation							
1.4.1.1	Supply current	I _{SUPP}	Without bridge and load current, bias adjustment ≤ 4, f _{CLK} ≤ 2.4MHz		2.5	4	mA
1.4.1.2	Supply current for current loop	I _{SUPP_CL}	Without bridge current, f _{CLK} ≤ 1.2MHz, bias [a] adjustment ≤ 1		2.0	2.75	mA
1.4.1.3	Temperature coefficient voltage reference *	T _{CREF}		-200	±50	200	ppm/K
1.4.2 Analog Front End							
1.4.2.1	Parasitic differential input offset current *	I _{IN_OFF}	Temperature range = T _{AMB_TQI} (-40 to 85°C)	-2 to -10		2 to 10	nA
1.4.3 DAC and Analog Output (OUT Pin)							
1.4.3.1	Output signal range [b]	V _{OUT_SR}	Voltage Mode, R _{LOAD} > 2KΩ V _{DDA_ADV} Temperature range = T _{AMB_TQI}	0.025		0.975	V _{DDA}
1.4.3.2	Output DNL	DNL _{OUT}	V _{DDA_ADV} Temperature range = T _{AMB_TQI}			0.95	LSB
1.4.3.3	Output INL [c]	INL _{OUT}				4	LSB
1.4.3.4	Output slew rate *	SR _{OUT}	Voltage Mode Load capacitance < 20nF Using conditions of 1.4.3.1	0.1			V/μs
1.4.3.5	Short circuit current *	I _{OUT_max}		5	10	20	mA
1.4.3.6	Addressable output signal range *	V _{OUT_ADR}	2048 steps	0		1	V _{DDA}
1.4.4 PWM Output (OUT Pin, IO1 Pin)							
1.4.4.1	PWM high voltage	V _{PWM_H}	Load resistance > 10kΩ	0.9			V _{DDA}
1.4.4.2	PWM low voltage	V _{PWM_L}	Load resistance > 10kΩ			0.1	V _{DDA}
1.4.4.3	PWM output slew rate *	SR _{PWM}	Load capacitance < 1nF	15			V/μs
1.4.5 Temperature Sensors (IR_TEMP Pin)							
1.4.5.1	Sensitivity external diode / resistor measurement	ST _{TS_E}	At r _{ADC} = 13 bits	75		210	μV/LSB

No.	Parameter	Symbol	Conditions	Min	Typ	Max	Unit
1.4.6 Digital Outputs (IO1, IO2, OUT Pins in Digital Mode)							
1.4.6.1	Output high level	V _{DOUT_H}	Load resistance > 1 kΩ	0.9			VDDA
1.4.6.2	Output low level	V _{DOUT_L}	Load resistance > 1 kΩ			0.1	VDDA
1.4.6.3	Output current *	I _{DOUT}		4			mA
1.4.7 System Response							
1.4.7.1	Startup time [d]	t _{STA}	Power-on to 1 st measurement result at output	2		5	ms
1.4.7.2	Response time *	t _{RESP}	66% change in input signal; refer to Table 3 for f _{CON}	1.66	2.66	3.66	1/f _{CON}
1.4.7.3	Overall accuracy (deviation from ideal line including INL, gain, and offset errors) *, [e]	A _{COUT}	T _{AMB_TQI} (-25 to 85 °C) & VDDA _{ADV}			0.10	%
			T _{AMB_TQA} (-40 to 125 °C) & VDDA _{ADV}			0.25	%
			T _{AMB_TQE} (-40 to 150 °C) & VDDA _{ADV}			0.50	%
1.4.7.4	Analog output noise: peak-to-peak *	V _{NOISE_PP}	Shorted inputs, gain ≤ 210 bandwidth ≤ 10kHz			10	mV
1.4.7.5	Analog output noise: RMS *	V _{NOISE_RMS}	Shorted inputs, gain ≤ 210 bandwidth ≤ 10kHz			3	mV
1.4.7.6	Ratiometricity error	RE _{OUT_5V}	±5% respectively 1000ppm ±10% (5V)			500	ppm
		RE _{OUT_3V}	±5% respectively 200ppm ±10% (3V)			1000	ppm
<p>[a] Recommended bias adjustment ≤ 4; note the application recommendations and power consumption adjustment constraints given in the ZSC31050 Application Note—Current Loop.</p> <p>[b] De-rated performance in lower part of supply voltage range (2.7 to 3.3V): 2.5 to 5 %VDDA and 95 to 97.5%VDDA.</p> <p>[c] Output linearity and accuracy can be enhanced by an additional analog output stage calibration.</p> <p>[d] OWI, start window disabled (depending on resolution and configuration, start routine begins approximately 0.8ms after power-on).</p> <p>[e] Accuracy better than 0.5% requires offset and gain calibration for the analog output stage; parameter only for ratiometric output. The current loop application is verified and validated for 5V operation only and external supply > 7V (upper limit is dependent on the external components used). Accuracy and temperature range should be validated based on the schematic design used. Refer to the ZSC31050 Application Note—Current Loop for more information.</p> <p>* For specifications marked with an asterisk (*), there is no measurement in mass production—the parameter is guaranteed by design and/or quality observations.</p>							

1.5 Interface Characteristics

No.	Parameter	Symbol	Conditions	Min	Typ	Max	Unit
1.5.1 Multiport Serial Interfaces (I²C, SPI)							
1.5.1.1	Input high level [a]	V _{I2C_IN_H}		0.7		1	V _{DDA}
				-		5.5	V _{DC}
1.5.1.2	Input low level	V _{I2C_IN_L}		0		0.3	V _{DDA}
1.5.1.3	Output low level	V _{I2C_OUT_L}				0.1	V _{DDA}
1.5.1.4	Load capacitance at the SDA pin	C _{SDA}				400	pF
1.5.1.5	Clock frequency at the SCL pin [b]	f _{SCL}	f _{CLK} ≥ 2MHz			400	kHz
1.5.1.6	Pull-up resistor	R _{I2C_PU}		500			Ω
1.5.1.7	Input capacitance (each pin)	C _{I2C_IN}	Also valid for SPI.			10	pF
1.5.2 One-Wire Serial Interface (ZACwire™)							
1.5.2.1	OWI start window	t _{OWI_start}			20		ms
1.5.2.2	Pull-up resistance master	R _{OWI_PU}		330			Ω
1.5.2.3	OWI load capacitance	C _{OWI_LOAD}	20μs < t _{OWI_BIT} < 100μs			0.08	t _{OWI_BIT} / R _{OWI_PU}
1.5.2.4	Voltage level low	V _{OWI_L}				0.2	V _{DDA}
1.5.2.5	Voltage level high	V _{OWI_H}		0.75			V _{DDA}
[a] The maximum value in V _{DC} is independent from V _{DDA} in I ² C Mode. [b] Internal clock frequency f _{CLK} must be at least 5 times higher than the communication clock frequency.							

2. Circuit Description

Note: This data sheet provides specifications and a general overview of ZSC31050 operation. For details of operation, including configuration settings and related EEPROM registers, refer to the *ZSC31050 Functional Description*.

2.1 Signal Flow

The ZSC31050's signal path includes both analog (shown in pink in Figure 1) and digital (blue) sections. The analog path is differential; i.e., the differential bridge sensor signal is handled internally via two signal lines that are symmetrical around a common mode potential (analog ground = $VDDA/2$), which improves noise rejection.

Therefore it is possible to amplify positive and negative input signals, which are located in the common mode range of the signal input.

Figure 1. Block Diagram of the ZSC31050

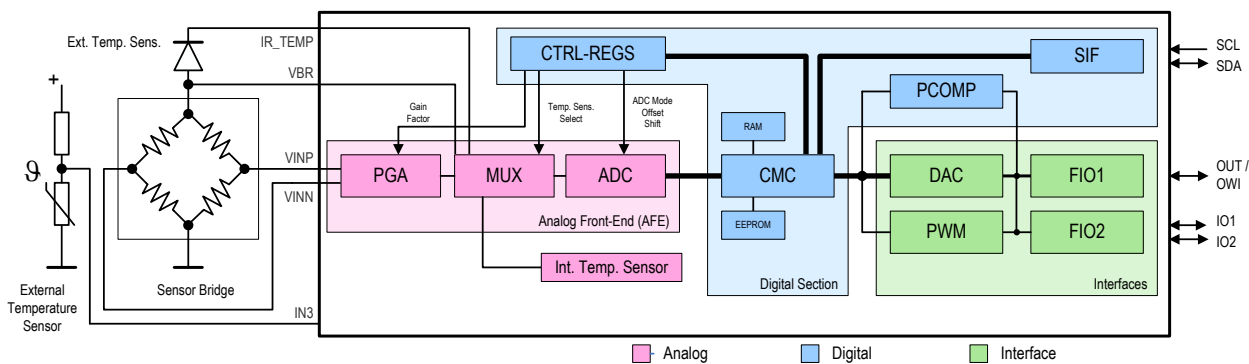

PGA	Programmable Gain Amplifier
MUX	Multiplexer
ADC	Analog-to-Digital Converter
CMC	Calibration Microcontroller
DAC	Digital-to-Analog Converter
FIO1	Flexible I/O 1: Analog Out (voltage/current), PWM2, ZACwire™ (one-wire-interface)
FIO2	Flexible I/O 2: PWM1, SPI Data Out, SPI Slave Select, Alarm1, Alarm2
SIF	Serial interface: I ² C Data I/O, SPI Data In, Clock
PCOMP	Programmable Comparator
EEPROM	Nonvolatile Memory for Calibration Parameters and Configuration
TS	On-Chip Temperature Sensor (pn-junction)
ROM	Memory for Correction Formula and Algorithm
PWM	PWM Module

The differential signal from the bridge sensor is pre-amplified by the programmable gain amplifier (PGA). The multiplexer (MUX) transmits the signals from the bridge sensor, external diode, or separate temperature sensor to the ADC in a specific sequence (the internal pn-junction (TS) can be used instead of the external temperature diode). Next, the ADC converts these signals into digital values.

The digital signal correction takes place in the calibration microcontroller (CMC). It is based on a special correction formula located in the ROM and sensor-specific coefficients (stored in the EEPROM during calibration). Depending on the programmed output configuration, the corrected sensor signal is output as an analog value, a PWM signal, or a digital value in the format of SPI, I²C, or ZACwire™. The output signal is provided at two flexible I/O modules (FIO) and at the serial interface (SIF). The configuration data and the correction parameters can be programmed into the EEPROM via the digital interfaces.

The modular circuit concept used in the design of the ZSC31050 allows fast customization of the IC for high-volume applications if needed. Circuit blocks and functions can be added or removed, which can reduce the die size (see section 7 for more details).

2.2 Application Modes

For each application, a configuration set must be established (generally prior to calibration) by programming the on-chip EEPROM regarding to the following modes:

- **Sensor channel**
 - Sensor mode: ratiometric voltage or current supply mode.
 - Input range: the gain of the analog front end must be chosen with respect to the maximum sensor signal span, which also requires adjusting the zero point of the ADC.
 - Additional offset compensation, the Extended Zero-Point Compensation (XZC), must be enabled if required; e.g., if the sensor offset voltage is close to or larger than the sensor span.
 - Resolution/response time: The ADC must be configured for resolution and conversion settings (1st or 2nd order). These settings influence the sampling rate, signal integration time, and, as a result, the noise immunity.
 - Polarity of the sensor bridge inputs: this allows inverting the sensor bridge inputs
- **Analog output**
 - Choice of output type (voltage value, current loop, or PWM) for output register 1.
 - Optional additional output register 2: PWM via IO1 pin or alarm out module via IO1 or IO2 pin.
- **Digital communication:** The protocol and its parameters must be selected.
- **Temperature**
 - The temperature sensor type for the temperature correction must be chosen (only main channel (T1) is usable for correction).
 - Optional: a secondary temperature sensor (T2) can be chosen as a second sensor output.
- **Supply voltage:** For non-ratiometric output, the voltage regulation must be configured.

Note: Not all possible combinations of settings are allowed (see section 2.5).

The calibration procedure must include establishing the coefficients for calibration calculation and the following steps depending on configuration:

- Adjustment of the extended offset compensation
- Zero compensation of temperature measurement
- Adjustment of the bridge current
- Settings for the reference voltage if using the reference voltage
- Settings for the thresholds and delays for the alarms if using the alarms

2.3 Analog Front-End (AFE)

The analog front-end consists of the programmable gain amplifier (PGA), the multiplexer (MUX), and the analog-to-digital converter (ADC).

2.3.1 Programmable Gain Amplifier (PGA)

The following tables show the adjustable gains, the sensor signal spans that can be processed, and the common mode range allowed.

Table 1. Adjustable Gains, Resulting Sensor Signal Spans, and Common Mode Ranges

No.	PGA Gain a_{IN}	Gain Amp1	Gain Amp2	Gain Amp3	Max. Span V_{IN_SP} in mV/V	Input Range V_{IN_CM} in % V_{DDA}^{\ddagger}
1	420	30	7	2	2	43 to 57
2	280	30	4.66	2	3	40 to 59
3	210	15	7	2	4	43 to 57
4	140	15	4.66	2	6	40 to 59
5	105	15	3.5	2	8	38 to 62
6	70	7.5	4.66	2	12	40 to 59
7	52.5	7.5	3.5	2	16	38 to 62
8	35	3.75	4.66	2	24	40 to 59
9	26.3	3.75	3.5	2	32	38 to 62
10	14	1	7	2	50	43 to 57
11	9.3	1	4.66	2	80	40 to 59
12	7	1	3.5	2	100	38 to 62
13	2.8	1	1.4	2	280	21 to 76

2.3.2 Extended Zero Point Compensation (XZC)

The ZSC31050 supports two methods of sensor offset cancellation (zero shift):

- Digital offset correction
- XZC – an analog cancellation for large offset values (up to approximately 300% of span)

The digital sensor offset correction is processed at the digital signal correction/conditioning by the CMC. The XZC analog sensor offset pre-compensation is needed for compensation of large offset values, which would overdrive the analog signal path due to uncompensated amplification. For analog sensor offset pre-compensation, a compensation voltage is added in the analog pre-gaining signal path (coarse offset removal). The analog offset compensation in the AFE can be adjusted by six EEPROM bits as described in the *ZSC31050 Functional Description*. It allows an analog zero-point shift of up to 300% of the segment of the signal span that can be processed.

[‡] Bridge in voltage mode; refer to the *ZSC31050 Functional Description* for the usable input signal / common mode range at the bridge in current mode.

The zero-point shift Z_{XZC} is calculated by equation (1):

$$\frac{V_{XZC}}{VDD_{BR}} = \frac{k \cdot Z_{XZC}}{20 \cdot a_{IN}} \quad (1)$$

Where

- V_{XZC} = Extended zero compensation voltage
- VDD_{BR} = Bridge voltage
- k = Calculation factor
- a_{IN} = Input gain

Table 2. Extended Zero Point Compensation (XZC) Range

PGA Gain a_{IN}	Max. Span V_{IN_SP} (mV/V)	Calculation Factor k	Offset Shift per Step (% Full Span)	Approx. Maximum Offset Shift (mV/V)	Approx. Maximum Shift (% V_{IN_SP}) (@ ± 20 Steps)
420	2	3.0	15%	+/- 7	330
280	3	1.833	9%	+/- 6	200
210	4	3.0	15%	+/- 14	330
140	6	1.833	9%	+/- 12	200
105	8	1.25	6%	+/- 12	140
70	12	1.833	9%	+/- 24	200
52.5	16	1.25	6%	+/- 22	140
35	24	1.833	9%	+/-48	200
26.3	32	1.25	6%	+/- 45	140
14	50	3.0	15%	+/- 180	330
9.3	80	1.833	9%	+/- 160	200
7	100	1.25	6%	+/- 140	140
2.8	280	0.2	1%	+/- 60	22

Note: Z_{XZC} can be adjusted in the range of -31 to 31 ; however, parameters are guaranteed only for -20 to 20 .

2.3.3 Measurement Cycle Performed by Multiplexer

Depending on EEPROM settings, the multiplexer selects the following inputs in a set sequence as shown in Figure 2.

Refer to the *ZSC31050 Functional Description* for EEPROM details.

- Internal offset of the input channel (auto-zero) measured by short circuiting the input
- Bridge temperature signal measured by external and internal diode (pn-junction)
- Bridge temperature signal measured by bridge resistors
- Temperature measured by external thermistor
- Pre-amplified bridge sensor signal

The complete measurement cycle is controlled by the CMC. The cycle diagram at the right shows its principle structure.

The EEPROM adjustable parameters are

- Measurement count n (bits 9:7 in configuration word CFGCYC):
n = <1, 2, 4, 8, 16, 32, 64, 128>
- Temperature 2 measurement enable, T2E = <0, 1>

After power-on, the start routine is called. It includes the bridge sensor and auto-zero measurement. It also measures the main temperature channel and its auto-zero if enabled.

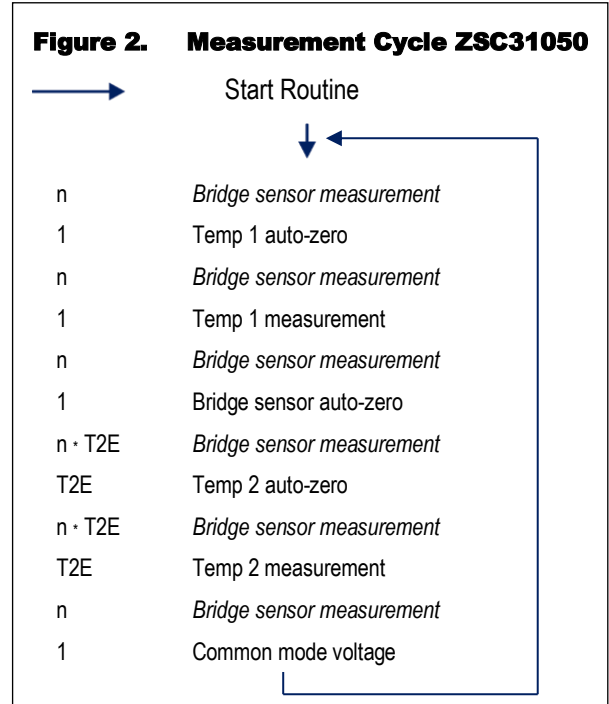

2.3.4 Analog-to-Digital Converter

The ADC is a charge-balancing converter using full differential switched capacitor technique. It can be used as a first or second order converter:

In the **first order** mode, the ADC is inherently monotone and insensitive against short and long term instability of the clock frequency. The conversion cycle time depends on the desired resolution and can be roughly calculated by equation (2):

$$t_{Cyc_1} = 2^{r_{ADC}} [\mu s] \tag{2}$$

The available ADC resolutions are $r_{ADC} = <9, 10, 11, 12, 13, 14>$.

In the **second order** mode, two conversions are stacked with the advantage of a much shorter conversion cycle time but with the drawback of a lower noise immunity caused by the shorter signal integration period. The conversion cycle time in this mode is roughly calculated by equation (3):

$$t_{Cyc_2} = 2^{\left(\frac{r_{ADC} + 3}{2}\right)} [\mu s] \tag{3}$$

The available ADC resolutions are $r_{ADC} = <11, 12, 13, 14, 15>$.

The result of the AD conversion is a relative counter result corresponding to equation (4):

$$Z_{ADC} = 2^{r_{ADC}} \cdot \left(\frac{V_{ADC_DIFF} + V_{ADC_OFF}}{V_{ADC_REF}} + 1 - RS_{ADC} \right) \tag{4}$$

- Z_{ADC} Number of counts; i.e., the result of the conversion)
- V_{ADC_DIFF} Differential input voltage of ADC: (a_{IN} * V_{IN_DIFF})
- V_{ADC_REF} Reference voltage of ADC: (VBR or VDDA)
- V_{ADC_OFF} Residual offset voltage of analog front-end to ADC
- RS_{ADC} Digital ADC range shift (RS_{ADC} = 1/2, 3/4, 7/8, 15/16, controlled by EEPROM setting)

A sensor input signal can be shifted via the RS_{ADC} value into the optimal input range of the ADC.

The potential at the VBR pin is used as the ADC’s reference voltage V_{ADC_REF} in “V_{ADC_REF} = VBR” mode. The mode is determined by the CFGAPP:ADCREF configuration register in EPPROM as described in the *ZSC31050 Functional Description*. Sensor bridges with no ratiometric behavior (e.g., temperature-compensated bridges) that are supplied by a constant current, require the VDDA potential as V_{ADC_REF} and this can be adjusted in the configuration. If this mode is enabled, XZC cannot be used (adjustment=0), but it must be enabled (refer to the calculation spreadsheet *ZSC31050_Bridge_Current_Excitation_Rev*.xls* for details).

Note: The AD conversion time (sample rate) is only part of the complete signal conditioning cycle.

Table 3. Output Resolution versus Sample Rate

ADC Order (O _{ADC})	Maximum Output Resolution				Sample Rate f _{CON}
	r _{ADC} §	Digital OUT	Analog OUT	r _{PWM}	f _{CLK} =2MHz
	(Bit)	(Bit)	(Bit)	(Bit)	(Hz)
1	9	9	9	9	1302
	10	10	10	10	781
	11	11	11	11	434
	12	12	11	12	230
	13	13	11	12	115
	14	14	11	12	59
2	10	10	10	10	3906
	11	11	11	11	3906
	12	12	11	12	3906
	13	13	11	12	1953
	14	14	11	12	1953
	15	15	11	12	977

§ ADC resolution should be 1 to 2 bits higher than applied output resolution

2.4 System Control

The system control is started by the internal power-on reset (POR) using the internal clock generator or an external clock. It has the following features:

- Control of the I/O functions and the measurement cycle using the EEPROM-stored configuration settings.
- 16-bit correction calculation for each measurement signal using the EEPROM-stored calibration coefficients and ROM-based algorithms.
- Error checking: To increase safety, the EEPROM data are verified via an EEPROM signature during the initialization procedure and the registers of the CMC are continuously observed with a parity check. If an error is detected, the error flag of the CMC is set and the outputs are driven to a diagnostic value. See section 2.7.

Note: Conditioning options include up to third-order sensor input correction (de-rated). The available adjustment ranges depend on the specific calibration parameters; basically, offset compensation and linear correction are only limited by the loss of resolution the compensation will cause. The second-order correction is possible up to approximately 20% of the full-scale difference from a straight line; third-order is possible up to approximately 10% (ADC resolution = 13 bits). The temperature calibration includes first and second order correction, which should be sufficient in almost all applications. ADC resolution also affects calibration options – each additional bit of resolution reduces the calibration range by approximately 50%.

2.5 Output Stage

The ZSC31050 provides the following I/O pins: OUT, IO1, IO2, and SDA. The signal formats listed in Table 4 can be output via these pins: analog (voltage or current), PWM, data (SPI/I²C), alarm. The following values can be provided at the I/O pins: bridge sensor signal, temperature signal 1, temperature signal 2, and alarms.

Note: The alarm signals (Alarm 1 and Alarm 2) only apply to the bridge sensor signal; they cannot be used as an alarm for the temperature signal.

Because some pins are dual-purpose, there are restrictions on the possible combinations for outputs and interface connections. Table 4 gives an overview of valid combinations. For some combinations in the SPI Mode, pin assignments depend on whether the ZSC31050 is in the Command Mode (CM) or the Normal Operation Mode (NOM) as indicated in the “Mode” column (refer to the ZSC31050 Functional Description for more details).

Note: In the SPI Mode, the IO2 pin is used as the Slave Select, so no Alarm 2 can be output in this mode.

Table 4. Output Configurations Overview

Configuration Number	SIF		I/O Pins Used				Mode
	I ² C	SPI	OUT	IO1	IO2	SDA	
1	✓					Data I/O	
2	✓			ALARM1		Data I/O	
3	✓				ALARM2	Data I/O	
4	✓			ALARM1	ALARM2	Data I/O	
5	✓			PWM1		Data I/O	
6	✓			PWM1	ALARM2	Data I/O	
7	✓		Analog			Data I/O	
8	✓		Analog	ALARM1		Data I/O	
9	✓		Analog		ALARM2	Data I/O	
10	✓		Analog	ALARM1	ALARM2	Data I/O	
11	✓		Analog	PWM1		Data I/O	

Configuration Number	SIF		I/O Pins Used				Mode
	I2C	SPI	OUT	IO1	IO2	SDA	
12	✓		Analog	PWM1	ALARM2	Data I/O	
13	✓		PWM2			Data I/O	
14	✓		PWM2	ALARM1		Data I/O	
15	✓		PWM2		ALARM2	Data I/O	
16	✓		PWM2	ALARM1	ALARM2	Data I/O	
17	✓		PWM2	PWM1		Data I/O	
18	✓		PWM2	PWM1	ALARM2	Data I/O	
19		✓		Data out (SDO)	Slave select	Data in	
20		✓		Data out (SDO)	Slave select	Data in	CM
	ALARM1			-	-	NOM	
21		✓		Data out	Slave select	Data in	CM
	PWM1			-	-	NOM	
22		✓	Analog	Data out	Slave select	Data in	
23		✓	Analog	Data out	Slave select	Data in	CM
	ALARM1			-	-	NOM	
24		✓	Analog	Data out	Slave select	Data in	CM
	PWM1			-	-	NOM	
25		✓	PWM2	Data out	Slave select	Data in	
26		✓	PWM2	Data out	Slave select	Data in	CM
	ALARM1			-	-	NOM	
27		✓	PWM2	Data out	Slave select	Data in	CM
	PWM1			-	-	NOM	

2.5.1 Analog Output

For analog output, three 15-bit registers store the compensated measurement results for the bridge sensor signal and temperature measurements 1 and 2. Each register can be independently switched to either the digital-to-analog converter module (DAC) or the PWM module (see Figure 1) and then output via the FIO1 or FIO2 output module connected to the OUT or IO1 pin respectively according to Table 5. Refer to the *ZSC31050 Functional Description* for details.

Table 5. Analog Output Configuration

Output Module	OUT	IO1
Voltage (DAC)	✓	
PWM	✓	✓

The voltage output module consists of an 11-bit resistor string DAC with a buffered output and a subsequent inverting amplifier with a class AB rail-to-rail operational amplifier. The two internal feedback networks are connected to the FBN and FBP pins. This structure offers wide flexibility for the output configuration; for example, voltage output, and 4mA to 20mA current loop output. Accidentally short-circuiting the analog output to VSS or VDPA does not damage the ZSC31050.

The PWM module outputs the analog measurement value via a stream of pulses with a duty cycle that is determined by the analog value. The PWM frequency depends on the resolution and clock divider settings. The maximum analog output resolution is 12 bits; however the maximum PWM frequency is 4kHz (9 bits). If both PWM2 and SPI protocol are activated (configuration numbers 25, 26, and 27 in Table 4), the output IO1 pin is shared between the PWM output and the SPI SDO output of the serial interface, and SPI interface communication (Command Mode) interrupts the PWM output.

2.5.2 Comparator Module (ALARM Output)

The comparator module consists of two comparator channels that can be connected to IO1 and IO2. Each can be independently programmed for threshold, hysteresis, switching direction, and on/off delay. A window comparator mode is also available.

2.5.3 Serial Digital Interface

The ZSC31050 includes a serial digital interface that is able to communicate in three different communication protocols: I²C, SPI, and ZACwire™ (one-wire communication). In SPI mode, the IO2 pin operates as the slave-select input, and the IO1 pin is the data output (SDO).

Initializing Communication

After power-on for approximately 20ms (the start window), the ZSC31050 interface is in the ZACwire™ mode, which allows communication via the one-wire interface (the OUT pin).

If a proper communication request is detected during the start window, the interface stays in the ZACwire™ mode (the Command Mode). This state can be left by set commands or a new power-on.

If no request is received during the start window, then the serial interface switches to communication via either I²C or SPI mode depending on EEPROM settings. The OUT pin can be used as an analog output or as a PWM output depending on EEPROM settings. The start window can be disabled (or enabled) by a special EEPROM setting.

For a detailed description of the serial interfaces, see the *ZSC31050 Functional Description*.

2.6 Voltage Regulator

For 3V to 5V ($\pm 10\%$) ratiometric output applications, the external supply voltage can be used for sensor element biasing. If an absolute analog output is required, then the internal voltage regulator with an external power regulation element (JFET) can be used. The regulation is bandgap-reference-based and designed for an external supply voltage V_{SUPP} in the range of 7V to 48V DC. The internal supply and sensor bridge voltage can be varied between 3V and 5.5V in four steps with the voltage regulator as determined by a configuration word in EEPROM.

2.7 Watchdog and Error Detection

The ZSC31050 detects various possible errors. A detected error is signaled by changing to a diagnostic mode. In this case, the analog output is set to the high or low level (maximum or minimum possible output value) depending on the error and the output registers of the digital serial interface are set to a correlated error code.

A watchdog continuously monitors the operation of the CMC and the progress of the measurement loop.

A continuous check of the sensor bridge for broken wires is done by two comparators monitoring the input voltage of each input [(VSSA + 0.5V) to (VDDA – 0.5V)]. The common mode voltage of the sensor is continuously monitored to detect sensor aging.

Different functions and blocks in the digital section are continuously monitored, including the RAM, ROM, EEPROM, and register contents.

See section 1.3.4 in the *ZSC31050 Functional Description* for a detailed description of all monitored blocks and methods of indicating errors.

3. Application Circuit Examples

Figure 3. Application Example 1

Typical ratiometric measurement with voltage output, temperature compensation via external diode, internal VDD regulator, and active sensor connection check (bridge must not be at VDDA)

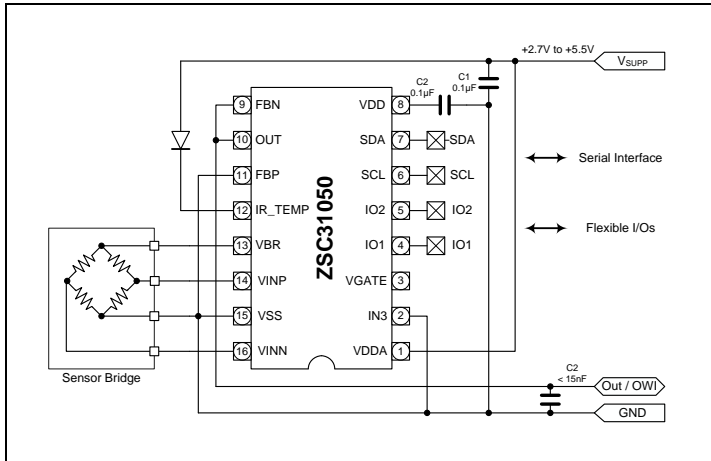

Figure 4. Application Example 2

0V to 10V output configuration with supply regulator (external JFET), temperature compensation via internal diode, and bridge in voltage mode

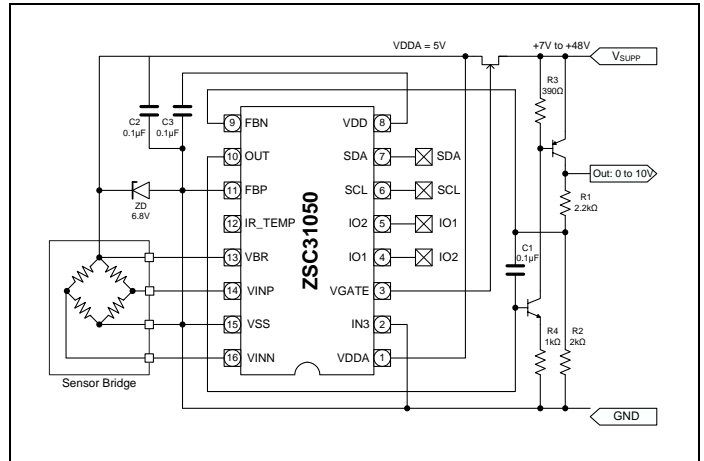

Figure 5. Application Example 3

Absolute voltage output, supply regulator (external JFET), constant current excitation of the sensor bridge, temperature compensation by bridge voltage drop measurement, internal VDD regulator without external capacitor

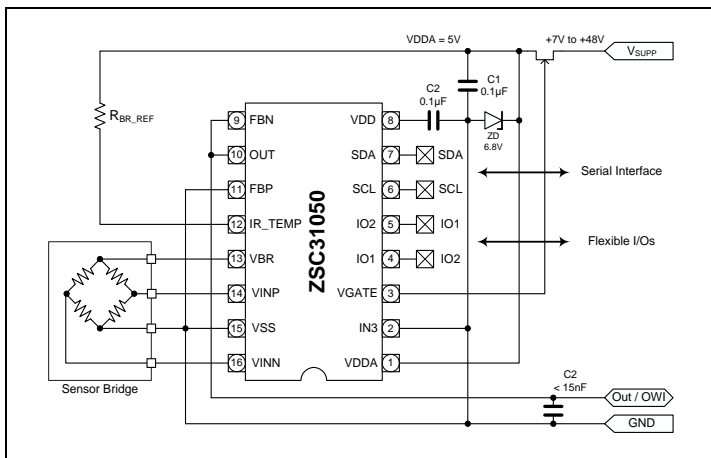

Figure 6. Application Example 4

Ratiometric bridge differential signal measurement, 3-wire connection for end-of-line calibration at OUT pin (ZACwire™), additional temperature measurement with external thermistor, and PWM output at IO1 pin

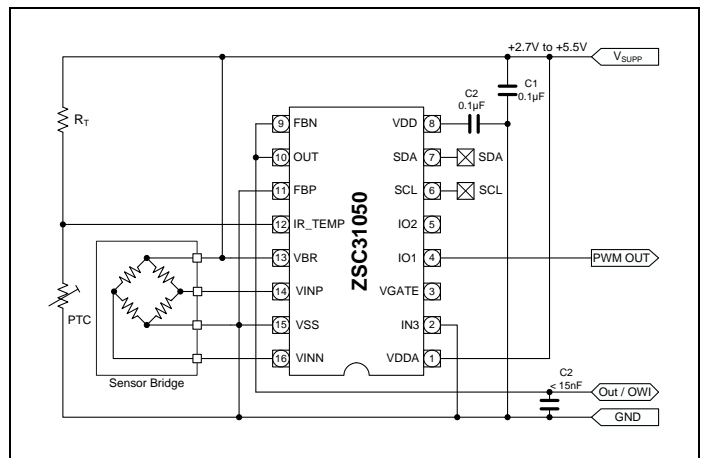
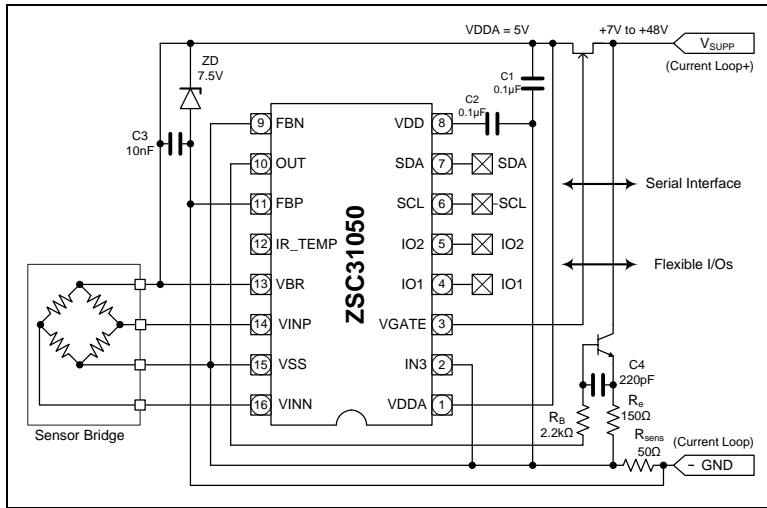

Figure 7. Application Example 5

Two-wire 4mA to 20mA configuration (7 to 48 V), temperature compensation via internal diode



Note: It is possible to combine or separate connectivity of different application examples. For VDD generation, Renesas recommends using the internal supply voltage regulator with an external capacitor. Refer the *ZSC31050 Application Note—Current Loop* for use of supply voltage regulation features (non-ratiometric mode) and current loop output mode.

4. ESD/Latch-Up-Protection

All pins have an ESD protection of >2000V, except the VINN, VINP, and FBP pins, which have an ESD protection >1200V. All pins have a latch-up protection of ±100mA or +8V/−4V (relative to VSS/VSSA). Refer to section 5 for details and restrictions. ESD protection referenced to the Human Body Model is tested with devices in 16-SSOP packages during product qualification. The ESD test follows the Human Body Model with 1.5kOhm/100pF based on MIL 883, method 3015.7.

5. Pin Configuration and Package

Table 6. Pin Configuration

Pin	Name	Description	Remarks	Latch-up Related Application Circuit Restrictions and/or Remarks
1	VDDA	Positive analog supply voltage	Supply	
2	IN3	Resistive temperature sensor IN and external clock IN	Analog IN	Freely accessible by application (vulnerable to latch-up if specifications in section 4 are exceeded)
3	VGATE	Gate voltage for external regulator FET	Analog OUT	Only connection to external JFET
4	IO1	SPI data out or ALARM1 or PWM1 Output	Digital IO	Freely accessible by application
5	IO2	SPI slave select or ALARM2	Digital IO	Freely accessible by application
6	SCL	I ² C clock or SPI clock	Digital IN, pull-up	Freely accessible by application
7	SDA	Data I/O for I ² C or data IN for SPI	Digital I/O, pull-up	Freely accessible by application
8	VDD	Positive digital supply voltage	Supply	Only capacitor to VSS is allowed; otherwise no application access
9	FBN	Negative feedback connection output stage	Analog I/O	Freely accessible by application
10	OUT	Analog output or PWM2 output or one-wire interface I/O	Analog OUT or Digital I/O	Freely accessible by application
11	FBP	Positive feedback connection output stage	Analog I/O	Freely accessible by application
12	IR_TEMP	Current source resistor I/O and temperature diode in	Analog I/O	Circuitry secures potential is within VSS-VDDA range; otherwise no application access
13	VBR	Bridge top sensing in bridge current out	Analog I/O	Only short to VDDA or connection to sensor bridge; otherwise no application access
14	VINP	Positive input from sensor bridge	Analog IN	Freely accessible by application
15	VSS	Negative supply voltage	Ground	
16	VINN	Negative input from sensor bridge	Analog IN	Freely accessible by application

The standard package for the ZSC31050 is a 16-SSOP (5.3mm body width) with lead-pitch 0.65mm:

Figure 8. Pin Configuration

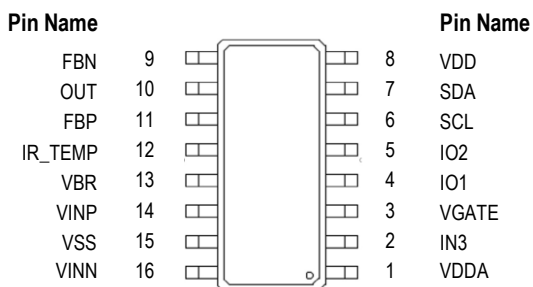

6. Reliability

The ZSC31050 is qualified according to the AEC-Q100 standard, operating temperature grade 0. A fit rate < 5fit (temp=55°C, S=60%) is guaranteed. A typical fit rate of the C7A technology that is used for the ZSC31050 is 2.5fit.

7. Customization

For high-volume applications that require an upgraded or downgraded functionality compared to the ZSC31050, Renesas can customize the circuit design by adding or removing certain functional blocks.

Renesas has a considerable library of sensor-dedicated circuitry blocks that enables Renesas to provide a custom solution quickly. Please contact Renesas for further information.

8. Ordering Information

Product Code	Description	Package
ZSC31050FEB	ZSC31050 Die — Temperature range: -40°C to +150°C	Unsawn on Wafer
ZSC31050FEC	ZSC31050 Die — Temperature range: -40°C to +150°C	Sawn on Wafer Frame
ZSC31050FEG1	ZSC31050 16-SSOP — Temperature range: -40°C to +150°C	Tube: add “-T” to sales code Reel: add “-R”
ZSC31050FAB	ZSC31050 Die — Temperature range: -40°C to +125°C	Unsawn on Wafer
ZSC31050FAC	ZSC31050 Die — Temperature range: -40°C to +125°C	Sawn on Wafer Frame
ZSC31050FAG1	ZSC31050 16-SSOP — Temperature range: -40°C to +125°C	Tube: add “-T” to sales code Reel: add “-R”
ZSC31050FIB	ZSC31050 Die — Temperature range: -25°C to +85°C	Unsawn on Wafer
ZSC31050FIC	ZSC31050 Die — Temperature range: -25°C to +85°C	Sawn on Wafer Frame
ZSC31050FIG1	ZSC31050 16-SSOP — Temperature range: -25°C to +85°C	Tube: add “-T” to sales code Reel: add “-R”
ZSC31050KITV3P1	ZSC31050 SSC Evaluation Kit V3.1: ZSC31050 Evaluation Board, SSC Communication Board, SSC Sensor Replacement Board, five ZSC31050 16-SSOP samples. Software is downloadable.	
ZSC31050MCSV1P1	Modular Mass Calibration System (MSC) V1.1 for ZSC31050: Four Mass Calibration Boards; SSC Communication Board; four ZSC31050 Mass Calibration Reference Boards, each with a ZSC31050 sample mounted; 30m 10-wire flat cable; 100 connectors. Software is downloadable.	

9. Related Documents

Visit the ZSC31050 product page (www.IDT.com/ZSC31050) or contact your nearest sales office for the latest version of this document and related documents.

10. Glossary

Term	Description
ADC	Analog-to-Digital Converter
AFE	Analog Front-End
CMC	Calibration Microcontroller
CMOS	Complementary Metal Oxide Semiconductor
DNL	Differential Nonlinearity
ESD	Electrostatic Device
FIO	Flexible Input/Output
FSO	Full Scale Output
IC	Integrated Circuit
INL	Integral Nonlinearity
MUX	Multiplexer
PGA	Programmable Gain Amplifier
POC	Power On Control
PWM	Pulse Width Modulation
PTC	Positive Temperature Coefficient
SIF	Serial Interface
T2E	Temperature 2 Measurement
TS	Temperature Sensor
XZC	Extended Zero-Point Compensation

11. Revision History

Date	Description
January 14, 2022	<ul style="list-style-type: none"> ▪ Updated PWM Frequency table in section 1.3.2.
March 18, 2020	<ul style="list-style-type: none"> ▪ Updated the paragraph before formula 1 in section 2.3.2.
February 13, 2017	<ul style="list-style-type: none"> ▪ Revision of maximum voltage supply range with external JFET from original 40V to revised specification 48V. ▪ Updates for part codes. ▪ Minor edits and formatting changes.
January 20, 2016	<p>Changed to IDT branding.</p>
July 27, 2015 (Rev. 1.21)	<ul style="list-style-type: none"> ▪ Update for order codes for ZSC31050 SSC Evaluation Kit. ▪ Update for contact information.
May 11, 2014 (Rev. 1.20)	<ul style="list-style-type: none"> ▪ Product has passed AEC-Q100 at temperature grade 0 (-40°C to 150°C). Related updates to page 2 and section 6. ▪ Update for contact information.
April 7, 2014 (Rev. 1.15)	<p>Related documents updated.</p>
December 11, 2013 (Rev. 1.14)	<p>Update for part ordering tables: Mass Calibration Kit no longer includes DVD of software. Software is now downloaded from website to ensure user has the latest version of the software.</p>
October 14, 2013 (Rev. 1.13)	<ul style="list-style-type: none"> ▪ Specification 1.2.4 for data retention for EEPROM changed to <i>minimum</i> 15 years. ▪ Specification 1.3.4 added for ADC input range. ▪ Added note to section 1.3.1 that first-order configuration of the ADC cannot be used with 15-bit resolution. ▪ Specification 1.4.7.3 updated to remove condition of current-loop output, etc. ▪ Minor edits for clarity.
July 7, 2013 (Rev. 1.12)	<ul style="list-style-type: none"> ▪ Addition of RB and C4 in to the current loop application circuit (Figure 7). ▪ Changed absolute maximum ratings for I²C interface. ▪ Updated contact information and imagery for cover and headers. ▪ Correction of equation (4). ▪ Removal of ZSC31050FCxx part numbers. ▪ Minor edits.
July 29, 2010 (Rev. 1.11)	<ul style="list-style-type: none"> ▪ Changed “Application Circuit Examples” in Figure 3 and Figure 7. ▪ Addition of current consumption in feature sheet area. ▪ New style for equation in section 2.3.2 and 2.3.4. ▪ Correction of calculation formula for Z_{ADC} in section 2.3.4. ▪ Minor edits to RS_{ADC} formula in section 2.3.4. ▪ Update of product name from ZMD31050 to ZSC31050.
February 18, 2010 (Rev. 1.10)	<ul style="list-style-type: none"> ▪ Changed CD to DVD in ordering code. ▪ Removed die/package option “F.” ▪ Minor edits.

Date	Description
February 16, 2010 (Rev. 1.08-1.09)	<ul style="list-style-type: none"> ▪ Addition of units for 1.4.1.2 and change in symbol for 1.5.2.1. ▪ Addition of new design for block diagram and all application schematics. ▪ Update for glossary. Addition of CM/nom information's in Table 4. ▪ Update for phone number for ZMD Far East, Ltd. ▪ Update for ordering codes description. ▪ Minor edits.
November 30, 2009 (Rev. 1.07)	<ul style="list-style-type: none"> ▪ Reformatted for new ZMDI template. ▪ Addition of "ZSC31050 Feature Sheet" section on pages 2 and 3. ▪ Addition of ordering codes for ZSC31050 and Evaluation Kits.
October 2009 (Rev. 1.05-1.06)	<ul style="list-style-type: none"> ▪ Update to "Related Documents" and "Document Revision History." ▪ Update of company references for ZMDI. ▪ New format for revision numbering in footer.
September 2009 (Rev. 1.04)	Reformatted with new ZMDI template.
1.03	<ul style="list-style-type: none"> ▪ Note 4 "Default Configuration" added in 5.4. ▪ Overall accuracy / values and conditions for current loop output added in 5.4.7.3. ▪ Reliability / fit rate values added in section 6.
1.01-1.02	<ul style="list-style-type: none"> ▪ Headlines and footnotes at all pages updated. ▪ Input capacitance of digital interface pins added in 5.5.1.7.
1.00	First release of document.

Notice

1. Descriptions of circuits, software and other related information in this document are provided only to illustrate the operation of semiconductor products and application examples. You are fully responsible for the incorporation or any other use of the circuits, software, and information in the design of your product or system. Renesas Electronics disclaims any and all liability for any losses and damages incurred by you or third parties arising from the use of these circuits, software, or information.
 2. Renesas Electronics hereby expressly disclaims any warranties against and liability for infringement or any other claims involving patents, copyrights, or other intellectual property rights of third parties, by or arising from the use of Renesas Electronics products or technical information described in this document, including but not limited to, the product data, drawings, charts, programs, algorithms, and application examples.
 3. No license, express, implied or otherwise, is granted hereby under any patents, copyrights or other intellectual property rights of Renesas Electronics or others.
 4. You shall be responsible for determining what licenses are required from any third parties, and obtaining such licenses for the lawful import, export, manufacture, sales, utilization, distribution or other disposal of any products incorporating Renesas Electronics products, if required.
 5. You shall not alter, modify, copy, or reverse engineer any Renesas Electronics product, whether in whole or in part. Renesas Electronics disclaims any and all liability for any losses or damages incurred by you or third parties arising from such alteration, modification, copying or reverse engineering.
 6. Renesas Electronics products are classified according to the following two quality grades: "Standard" and "High Quality". The intended applications for each Renesas Electronics product depends on the product's quality grade, as indicated below.
 - "Standard": Computers; office equipment; communications equipment; test and measurement equipment; audio and visual equipment; home electronic appliances; machine tools; personal electronic equipment; industrial robots; etc.
 - "High Quality": Transportation equipment (automobiles, trains, ships, etc.); traffic control (traffic lights); large-scale communication equipment; key financial terminal systems; safety control equipment; etc.
- Unless expressly designated as a high reliability product or a product for harsh environments in a Renesas Electronics data sheet or other Renesas Electronics document, Renesas Electronics products are not intended or authorized for use in products or systems that may pose a direct threat to human life or bodily injury (artificial life support devices or systems; surgical implantations; etc.), or may cause serious property damage (space system; undersea repeaters; nuclear power control systems; aircraft control systems; key plant systems; military equipment; etc.). Renesas Electronics disclaims any and all liability for any damages or losses incurred by you or any third parties arising from the use of any Renesas Electronics product that is inconsistent with any Renesas Electronics data sheet, user's manual or other Renesas Electronics document.
7. No semiconductor product is absolutely secure. Notwithstanding any security measures or features that may be implemented in Renesas Electronics hardware or software products, Renesas Electronics shall have absolutely no liability arising out of any vulnerability or security breach, including but not limited to any unauthorized access to or use of a Renesas Electronics product or a system that uses a Renesas Electronics product. RENESAS ELECTRONICS DOES NOT WARRANT OR GUARANTEE THAT RENESAS ELECTRONICS PRODUCTS, OR ANY SYSTEMS CREATED USING RENESAS ELECTRONICS PRODUCTS WILL BE INVULNERABLE OR FREE FROM CORRUPTION, ATTACK, VIRUSES, INTERFERENCE, HACKING, DATA LOSS OR THEFT, OR OTHER SECURITY INTRUSION ("Vulnerability Issues"). RENESAS ELECTRONICS DISCLAIMS ANY AND ALL RESPONSIBILITY OR LIABILITY ARISING FROM OR RELATED TO ANY VULNERABILITY ISSUES. FURTHERMORE, TO THE EXTENT PERMITTED BY APPLICABLE LAW, RENESAS ELECTRONICS DISCLAIMS ANY AND ALL WARRANTIES, EXPRESS OR IMPLIED, WITH RESPECT TO THIS DOCUMENT AND ANY RELATED OR ACCOMPANYING SOFTWARE OR HARDWARE, INCLUDING BUT NOT LIMITED TO THE IMPLIED WARRANTIES OF MERCHANTABILITY, OR FITNESS FOR A PARTICULAR PURPOSE.
 8. When using Renesas Electronics products, refer to the latest product information (data sheets, user's manuals, application notes, "General Notes for Handling and Using Semiconductor Devices" in the reliability handbook, etc.), and ensure that usage conditions are within the ranges specified by Renesas Electronics with respect to maximum ratings, operating power supply voltage range, heat dissipation characteristics, installation, etc. Renesas Electronics disclaims any and all liability for any malfunctions, failure or accident arising out of the use of Renesas Electronics products outside of such specified ranges.
 9. Although Renesas Electronics endeavors to improve the quality and reliability of Renesas Electronics products, semiconductor products have specific characteristics, such as the occurrence of failure at a certain rate and malfunctions under certain use conditions. Unless designated as a high reliability product or a product for harsh environments in a Renesas Electronics data sheet or other Renesas Electronics document, Renesas Electronics products are not subject to radiation resistance design. You are responsible for implementing safety measures to guard against the possibility of bodily injury, injury or damage caused by fire, and/or danger to the public in the event of a failure or malfunction of Renesas Electronics products, such as safety design for hardware and software, including but not limited to redundancy, fire control and malfunction prevention, appropriate treatment for aging degradation or any other appropriate measures. Because the evaluation of microcomputer software alone is very difficult and impractical, you are responsible for evaluating the safety of the final products or systems manufactured by you.
 10. Please contact a Renesas Electronics sales office for details as to environmental matters such as the environmental compatibility of each Renesas Electronics product. You are responsible for carefully and sufficiently investigating applicable laws and regulations that regulate the inclusion or use of controlled substances, including without limitation, the EU RoHS Directive, and using Renesas Electronics products in compliance with all these applicable laws and regulations. Renesas Electronics disclaims any and all liability for damages or losses occurring as a result of your noncompliance with applicable laws and regulations.
 11. Renesas Electronics products and technologies shall not be used for or incorporated into any products or systems whose manufacture, use, or sale is prohibited under any applicable domestic or foreign laws or regulations. You shall comply with any applicable export control laws and regulations promulgated and administered by the governments of any countries asserting jurisdiction over the parties or transactions.
 12. It is the responsibility of the buyer or distributor of Renesas Electronics products, or any other party who distributes, disposes of, or otherwise sells or transfers the product to a third party, to notify such third party in advance of the contents and conditions set forth in this document.
 13. This document shall not be reprinted, reproduced or duplicated in any form, in whole or in part, without prior written consent of Renesas Electronics.
 14. Please contact a Renesas Electronics sales office if you have any questions regarding the information contained in this document or Renesas Electronics products.

(Note1) "Renesas Electronics" as used in this document means Renesas Electronics Corporation and also includes its directly or indirectly controlled subsidiaries.

(Note2) "Renesas Electronics product(s)" means any product developed or manufactured by or for Renesas Electronics.

(Disclaimer Rev.5.0-1 October 2020)

Corporate Headquarters

TOYOSU FORESIA, 3-2-24 Toyosu,
Koto-ku, Tokyo 135-0061, Japan
www.renesas.com

Trademarks

Renesas and the Renesas logo are trademarks of Renesas Electronics Corporation. All trademarks and registered trademarks are the property of their respective owners.

Contact Information

For further information on a product, technology, the most up-to-date version of a document, or your nearest sales office, please visit:
www.renesas.com/contact/

Looking for pricing, stock, or lifecycle information?

Click below to explore more details on WIN SOURCE:

 [View STM32F446VET7 on WIN SOURCE](#)

 [STMicroelectronics Information](#)

Optimize Your Supply Chain with WIN SOURCE Solutions

-  Global Sourcing Solution
-  Obsolete Management
-  Cost Control Management
-  Shortage Management
-  Alternative Solution
-  Excess Inventory Management