



**THE DATASHEET OF
CY8C4014LQS-422**



PSoC™ 4000 Automotive MCU

Based on Arm® Cortex®-M0 CPU

General description

PSoC™ 4 is a scalable and reconfigurable platform architecture for a family of programmable embedded system controllers with an Arm® Cortex®-M0 CPU, while being AEC-Q100-compliant. It combines programmable and reconfigurable analog and digital blocks with flexible automatic routing. The PSoC™ 4000 product family is the smallest member of the PSoC™ 4 platform architecture. It is a combination of a microcontroller with standard communication and timing peripherals, a capacitive touch-sensing system (CAPSENSE™) with best-in-class performance, and general-purpose analog. PSoC™ 4000 products will be fully upward compatible with members of the PSoC™ 4 platform for new applications and design needs.

Features

- 32-bit MCU subsystem
 - 16-MHz Arm® Cortex®-M0 CPU
 - Up to 16 KB of flash with Read Accelerator
 - Up to 2 KB of SRAM
- Programmable Analog
 - Two current DACs (IDACs) for general-purpose or capacitive sensing applications
 - One low-power comparator with internal reference
- Low power 1.71-V to 5.5-V operation
 - Deep Sleep mode with wake-up on interrupt and I²C address detect
- Capacitive sensing
 - Capacitive sigma-delta provides best-in-class signal-to-noise ratio (SNR) and water tolerance
 - Infineon-supplied software component makes capacitive sensing design easy
 - Automatic hardware tuning (SmartSense)
- Serial communication
 - Multi-master I²C block with the ability to do address matching during Deep Sleep and generate a wake-up on match
- Timing and pulse-width modulation
 - One 16-bit timer/counter/pulse-width modulator (TCPWM) block
 - Center-aligned, Edge, and Pseudo-Random modes
 - Comparator-based triggering of Kill signals for motor drive and other high-reliability digital logic applications
- Up to 20 programmable GPIO pins
 - 24-pin QFN and 16-pin SOIC packages
 - GPIO pins on Ports 0, 1, and 2 can be CAPSENSE™ or have other functions
 - Drive modes, strengths, and slew rates are programmable
- Temperature ranges
 - A-Grade: -40°C to +85°C
 - S-Grade: -40°C to +105°C
 - E-Grade: -40°C to +125°C
 - Automotive Electronics Council (AEC) Q100 qualified
- PSoC™ Creator Design Environment
 - Integrated Development Environment (IDE) provides schematic design entry and build (with analog and digital automatic routing)
 - Applications Programming Interface (API) component for all fixed-function and programmable peripherals
- Industry-Standard Tool Compatibility
 - After schematic entry, development can be done with Arm®-based industry-standard development tools

Block diagram

Block diagram

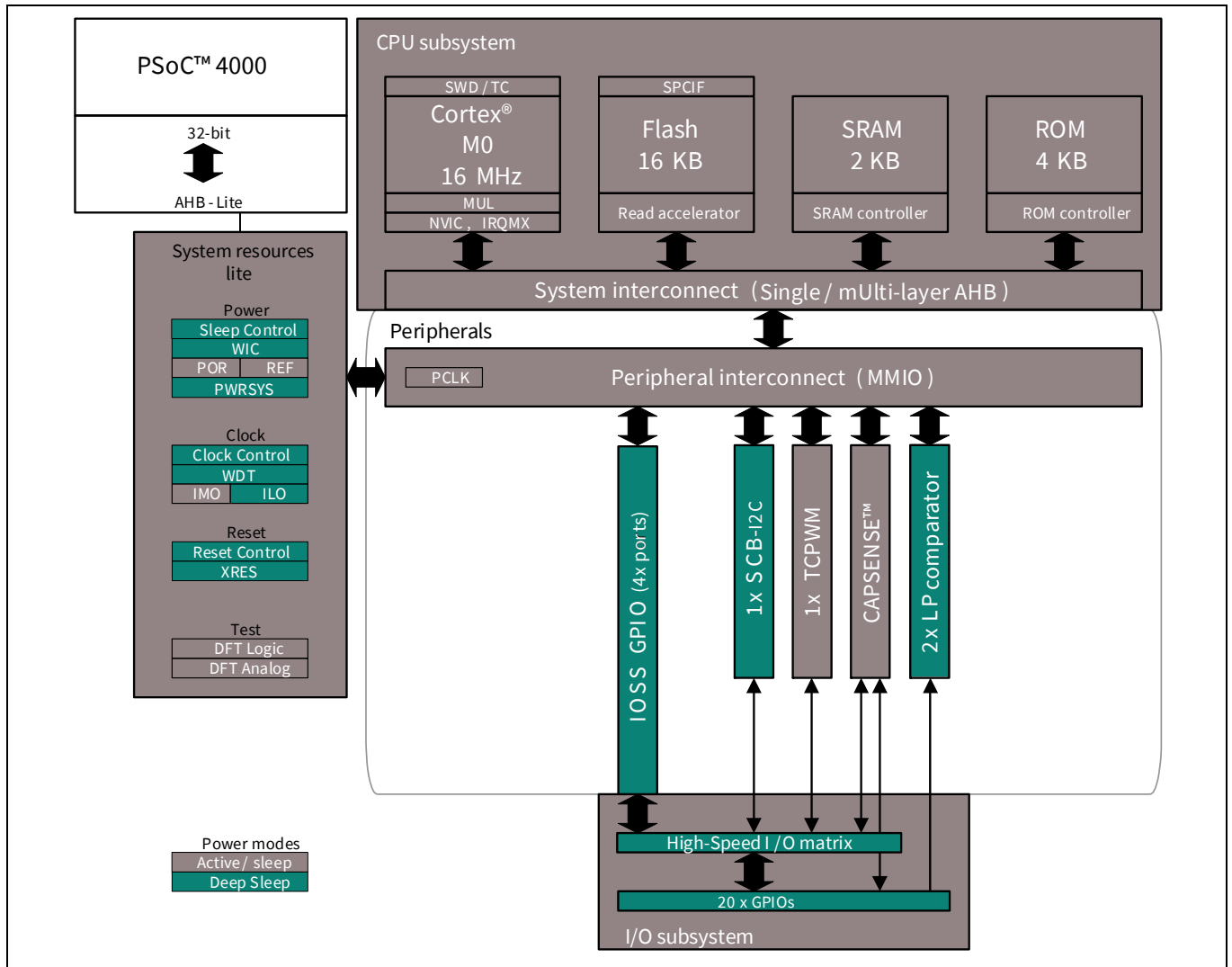

Table of contents

General description	1
Features	1
Block diagram	2
Table of contents	3
1 Functional description	4
2 Functional overview	4
2.1 CPU and memory subsystem	4
2.2 System resources	5
2.3 Analog blocks	6
2.4 Fixed function digital	6
2.5 GPIO	7
2.6 Special function peripherals	7
3 Pinouts	8
4 Power	10
4.1 Unregulated external supply	10
4.2 Regulated external supply	11
5 Development support	12
5.1 Documentation	12
5.2 Online	12
5.3 Tools	12
6 Electrical Specifications	13
6.1 Absolute Maximum Ratings	13
6.2 Device Level Specifications	13
6.3 Analog peripherals	18
6.4 Digital peripherals	20
6.5 Memory	21
6.6 System resources	21
7 Ordering information	24
7.1 Part numbering conventions	24
8 Packaging	26
8.1 Package outline drawings	27
9 Acronyms	29
10 Document conventions	33
10.1 Units of measure	33
Revision history	34

1 Functional description

PSoC™ 4000 devices include extensive support for programming, testing, debugging, and tracing both hardware and firmware.

The Arm® Serial-Wire Debug (SWD) interface supports all programming and debug features of the device.

Complete debug-on-chip functionality enables full-device debugging in the final system using the standard production device. It does not require special interfaces, debugging pods, simulators, or emulators. Only the standard programming connections are required to fully support debug.

The PSoC™ Creator IDE provides fully integrated programming and debug support for the PSoC™ 4000 devices. The SWD interface is fully compatible with industry-standard third-party tools. The PSoC™ 4000 family provides a level of security not possible with multi-chip application solutions or with microcontrollers.

It has the following advantages:

- Allows disabling of debug features
- Robust flash protection
- Allows customer-proprietary functionality to be implemented in on-chip programmable blocks

The debug circuits are enabled by default and can only be disabled in firmware. If they are not enabled, the only way to re-enable them is to erase the entire device, clear flash protection, and reprogram the device with new firmware that enables debugging.

Additionally, all device interfaces can be permanently disabled (device security) for applications concerned about phishing attacks due to a maliciously reprogrammed device or attempts to defeat security by starting and interrupting flash programming sequences. All programming, debug, and test interfaces are disabled when maximum device security is enabled. Therefore, PSoC™ 4000, with device security enabled, will have only limited capability for failure analysis. This is a trade-off the PSoC™ 4000 allows the customer to make.

2 Functional overview

2.1 CPU and memory subsystem

2.1.1 CPU

The Cortex®-M0 CPU in the PSoC™ 4000 is part of the 32-bit MCU subsystem, which is optimized for low-power operation with extensive clock gating. Most instructions are 16 bits in length and the CPU executes a subset of the Thumb-2 instruction set. This enables fully compatible, binary, upward migration of the code to higher performance processors, such as the Cortex-M3 and M4. It includes a Nested Vectored Interrupt Controller (NVIC) block with eight interrupt inputs and also includes a Wakeup Interrupt Controller (WIC). The WIC can wake the processor from the Deep Sleep mode, allowing power to be switched OFF to the main processor when the chip is in the Deep Sleep mode.

The CPU also includes a debug interface, the SWD interface, which is a 2-wire form of JTAG. The debug configuration used for PSoC™ 4000 has four breakpoint (address) comparators and two watchpoint (data) comparators.

2.1.2 Flash

The PSoC™ 4000 device has a flash module with a flash accelerator, tightly coupled to the CPU to improve average access times from the flash block. The low-power flash block is designed to deliver zero wait-state (WS) access time at 16 MHz. The flash accelerator delivers 85% of the single-cycle SRAM access performance on average.

2.1.3 SRAM

Two KB of SRAM are provided with zero wait-state access at 16 MHz.

2.1.4 SROM

A supervisory ROM that contains boot and configuration routines is provided.

2.2 System resources

2.2.1 Power system

The power system is described in detail in the section on “**Power**” on page 10. It provides an assurance that voltage levels are as required for each respective mode and either delays mode entry (for example, on power-on reset (POR)) until voltage levels are as required for proper functionality, or generates resets (for example, on brown-out detection). The PSoC™ 4000 operates with a single external supply over the range of either 1.8 V \pm 5% (externally regulated) or 1.8 V to 5.5 V (internally regulated) and has three different power modes, transitions between which are managed by the power system. The PSoC™ 4000 provides Active, Sleep, and Deep Sleep low-power modes.

All subsystems are operational in Active mode. The CPU subsystem (CPU, flash, and SRAM) is clock-gated OFF in the Sleep mode, while all peripherals and interrupts are active with instantaneous wake-up on a wake-up event. In Deep Sleep mode, the high-speed clock and associated circuitry is switched OFF; wake-up from this mode takes 35 μ s.

2.2.2 Clock system

The PSoC™ 4000 clock system is responsible for providing clocks to all subsystems that require clocks and for switching between different clock sources without glitching. In addition, the clock system ensures that there are no metastable conditions.

The clock system for the PSoC™ 4000 consists of the internal main oscillator (IMO) and the internal low-frequency oscillator (ILO) and provision for an external clock.

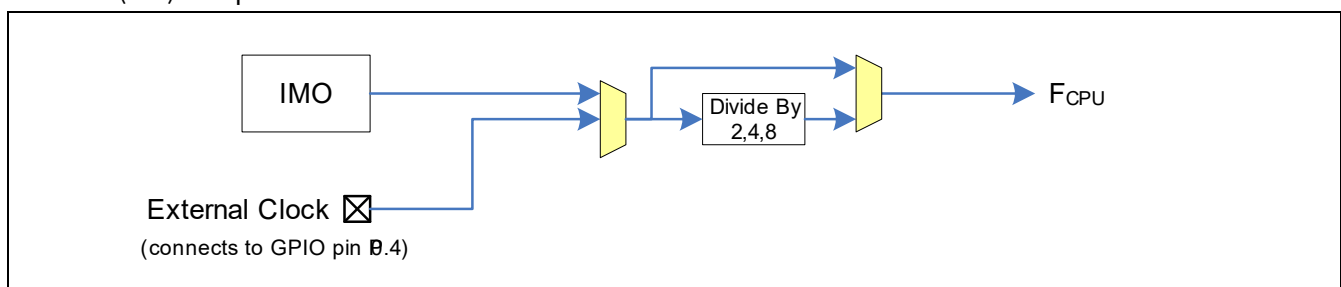

Figure 1 PSoC™ 4000 MCU clocking architecture

The F_{CPU} signal can be divided down to generate synchronous clocks for the analog and digital peripherals. There are four clock dividers for the PSoC™ 4000, each with 16-bit divide capability. The 16-bit capability allows flexible generation of fine-grained frequency values and is fully supported in PSoC™ Creator.

2.2.3 IMO clock source

The IMO is the primary source of internal clocking in the PSoC™ 4000. It is trimmed during testing to achieve the specified accuracy. The IMO default frequency is 24 MHz and it can be adjusted from 24 to 48 MHz in steps of 4 MHz. The IMO tolerance with Infineon-provided calibration settings is \pm 2% (24 and 32 MHz).

2.2.4 ILO clock source

The ILO is a very low power, 40-kHz oscillator, which is primarily used to generate clocks for the watchdog timer (WDT) and peripheral operation in Deep Sleep mode. ILO-driven counters can be calibrated to the IMO to improve accuracy. Infineon provides a software component, which does the calibration.

2.2.5 Watchdog timer (WDT)

The WDT is implemented in the clock block running from the ILO; this allows watchdog operation during Deep Sleep and generates a watchdog reset, if not serviced before the set timeout occurs. The watchdog reset is recorded in a Reset Cause register, which is firmware readable.

2.2.6 Reset

The PSoC™ 4000 can be reset from a variety of sources including a software reset. Reset events are asynchronous and guarantee reversion to a known state. The reset cause is recorded in a register, which is sticky through reset and allows software to determine the cause of the reset. An XRES pin is reserved for external reset on the 24-pin package. An internal POR is provided on the 16-pin package. The XRES pin has an internal pull-up resistor that is always enabled.

2.2.7 Voltage reference

The PSoC™ 4000 reference system generates all internally required references. A 1.2-V voltage reference is provided for the comparator. The IDACs are based on a $\pm 5\%$ reference.

2.3 Analog blocks

2.3.1 Low-power comparators

The PSoC™ 4000 has a low-power comparator, which uses the built-in voltage reference. Any one of up to 16 pins can be used as a comparator input and the output of the comparator can be brought out to a pin. The selected comparator input is connected to the minus input of the comparator with the plus input always connected to the 1.2-V voltage reference.

2.3.2 Current DACs

The PSoC™ 4000 has two IDACs, which can drive any of up to 16 pins on the chip. These IDACs have programmable current ranges.

2.3.3 Analog multiplexed buses

The PSoC™ 4000 has two concentric independent buses that go around the periphery of the chip. These buses (called amux buses) are connected to firmware-programmable analog switches that allow the chip's internal resources (IDACs, comparator) to connect to any pin on Ports 0, 1, and 2.

2.4 Fixed function digital

2.4.1 Timer/Counter/PWM (TCPWM) block

The TCPWM block consists of a 16-bit counter with user-programmable period length. There is a capture register to record the count value at the time of an event (which may be an I/O event), a period register that is used to either stop or auto-reload the counter when its count is equal to the period register, and compare registers to generate compare value signals that are used as PWM duty cycle outputs. The block also provides true and complementary outputs with programmable offset between them to allow use as dead-band programmable complementary PWM outputs. It also has a Kill input to force outputs to a predetermined state; for example, this is used in motor drive systems when an over-current state is indicated and the PWM driving the FETs needs to be shut off immediately with no time for software intervention.

2.4.2 Serial communication block (SCB)

The PSoC™ 4000 has a serial communication block, which implements a multi-master I²C interface.

I²C mode: The hardware I²C block implements a full multi-master and slave interface (it is capable of multi-master arbitration). This block is capable of operating at speeds of up to 400 kbps (Fast Mode) and has flexible buffering options to reduce interrupt overhead and latency for the CPU. It also supports EZI²C that creates a mailbox address range in the memory of the PSoC™ 4000 and effectively reduces I²C communication to reading from and writing to an array in memory. In addition, the block supports an 8-deep FIFO for receive and

transmit which, by increasing the time given for the CPU to read data, greatly reduces the need for clock stretching caused by the CPU not having read data on time.

The I²C peripheral is compatible with the I²C Standard-mode and Fast-mode devices as defined in the NXP I²C-bus specification and user manual (UM10204). The I²C bus I/O is implemented with GPIO in open-drain modes.

The PSoC™ 4000 is not completely compliant with the I²C spec in the following respect:

- GPIO cells are not overvoltage tolerant and, therefore, cannot be hot-swapped or powered up independently of the rest of the I²C system.

2.5 GPIO

The PSoC™ 4000 has up to 20 GPIOs. The GPIO block implements the following:

- Eight drive modes:
 - Analog input mode (input and output buffers disabled)
 - Input only
 - Weak pull-up with strong pull-down
 - Strong pull-up with weak pull-down
 - Open drain with strong pull-down
 - Open drain with strong pull-up
 - Strong pull-up with strong pull-down
 - Weak pull-up with weak pull-down
- Input threshold select (CMOS or LVTTTL).
- Individual control of input and output buffer enabling/disabling in addition to the drive strength modes
- Selectable slew rates for dV/dt related noise control to improve EMI

The pins are organized in logical entities called ports, which are 8-bit in width (less for Ports 2 and 3). During power-on and reset, the blocks are forced to the disable state so as not to crowbar any inputs and/or cause excess turn-on current. A multiplexing network known as a high-speed I/O matrix is used to multiplex between various signals that may connect to an I/O pin.

Data output and pin state registers store, respectively, the values to be driven on the pins and the states of the pins themselves.

Every I/O pin can generate an interrupt if so enabled and each I/O port has an interrupt request (IRQ) and interrupt service routine (ISR) vector associated with it (4 for PSoC™ 4000).

2.6 Special function peripherals

2.6.1 CAPSENSE™

CAPSENSE™ is supported in the PSoC™ 4000 through a CSD block that can be connected to up to 16 pins through an analog mux bus via an analog switch (pins on Port 3 are not available for CAPSENSE™ purposes). CAPSENSE™ function can thus be provided on any available pin or group of pins in a system under software control. A PSoC™ Creator component is provided for the CAPSENSE™ block to make it easy for the user.

Shield voltage can be driven on another mux bus to provide water-tolerance capability. Water tolerance is provided by driving the shield electrode in phase with the sense electrode to keep the shield capacitance from attenuating the sensed input. Proximity sensing can also be implemented.

The CAPSENSE™ block has two IDACs, which can be used for general purposes if CAPSENSE™ is not being used (both IDACs are available in that case) or if CAPSENSE™ is used without water tolerance (one IDAC is available).

3 Pinouts

The following is the pin list for PSoC™ 4000. All Port pins support GPIO. Ports 0, 1, and 2 support CSD CAPSENSE™ and analog mux bus connections.

Table 1 PSoC™ 4000 pin descriptions

24-pin QFN		16-pin SOIC		TCPWM signals	Alternate functions
Pin	Name	Pin	Name		
1	P0.0/TRIN0	–	–	TRIN0: Trigger Input 0	–
2	P0.1/TRIN1/ CMPO_0	3	P0.1/TRIN1/CMPO_0	TRIN1: Trigger Input 1	CMPO_0: Sense Comp Out
3	P0.2/TRIN2	4	P0.2/TRIN2	TRIN2: Trigger Input 2	–
4	P0.3/TRIN3	–	–	TRIN3: Trigger Input 3	–
5	P0.4/TRIN4/ CMPO_0/EXT_CLK	5	P0.4/TRIN4/CMPO_0/ EXT_CLK	TRIN4: Trigger Input 4	CMPO_0: Sense Comp Out, External Clock, CMOD Cap
6	VCCD	6	VCCD	–	–
7	VDD	7	VDD	–	–
8	VSS	8	VSS	–	–
9	P0.5	9	P0.5	–	–
10	P0.6	10	P0.6	–	–
11	P0.7	–	–	–	–
12	P1.0	–	–	–	–
13	P1.1/OUT0	11	P1.1/OUT0	OUT0: PWM OUT 0	–
14	P1.2/SCL	12	P1.2/SCL	–	I2C Clock
15	P1.3/SDA	13	P1.3/SDA	–	I2C Data
16	P1.4/UNDO	–	–	UNDO: Underflow Out	–
17	P1.5/OVF0	–	–	OVF0: Overflow Out	–
18	P1.6/OVF0/UNDO/ nOUT0/CMPO_0	14	P1.6/OVF0/UNDO/ nOUT0/CMPO_0	nOUT0: Complement of OUT0 (not OUT)	CMPO_0: Sense Comp Out, Internal Reset function during POR (must not have load to ground during POR).
19	P1.7/MATCH/EXT _CLK	15	P1.7/MATCH/EXT_CLK	MATCH: Match Out	External Clock
20	P2.0	16	P2.0	–	–
21	P3.0/SDA/ SWD_IO	1	P3.0/SDA/ SWD_IO	–	I2C Data, SWD IO
22	P3.1/SCL/ SWD_CLK	2	P3.1/SCL/ SWD_CLK	–	I2C Clock, SWD Clock
23	P3.2	–	–	OUT0: PWM OUT 0	–
24	XRES	–	–	–	XRES: External Reset

Pinouts

Descriptions of the pin functions are as follows:

VDD: Power supply for both analog and digital sections.

VSS: Ground pin.

VCCD: Regulated digital supply (1.8 V ±5%).

Pins belonging to Ports 0, 1, and 2 can all be used as CSD sense and shield pins can be connected to AMUXBUS A or B or can all be used as GPIO pins that can be driven by the firmware.

Pins on Port 3 can be used as GPIO, in addition to their alternate functions listed above.

The following packages are provided: 24-pin QFN and 16-pin SOIC.

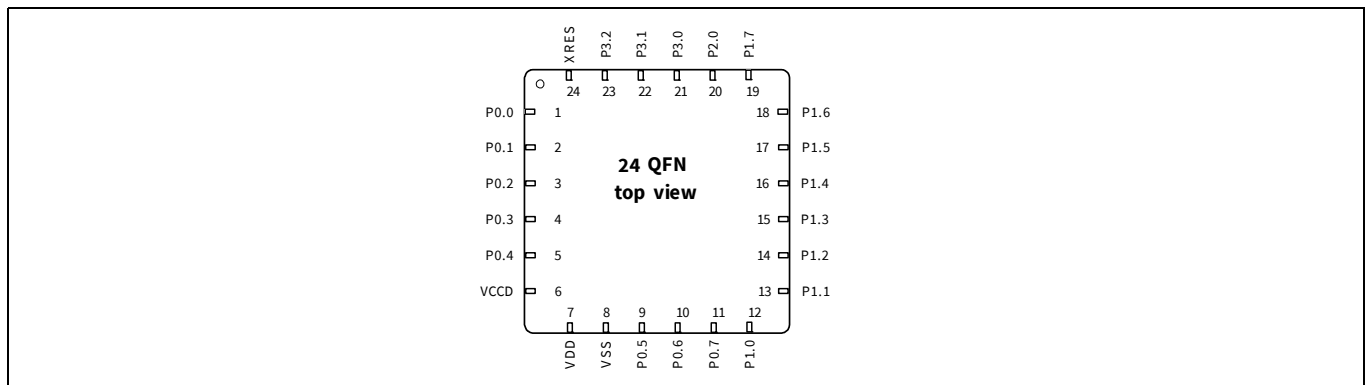

Figure 2 24-pin QFN pinout

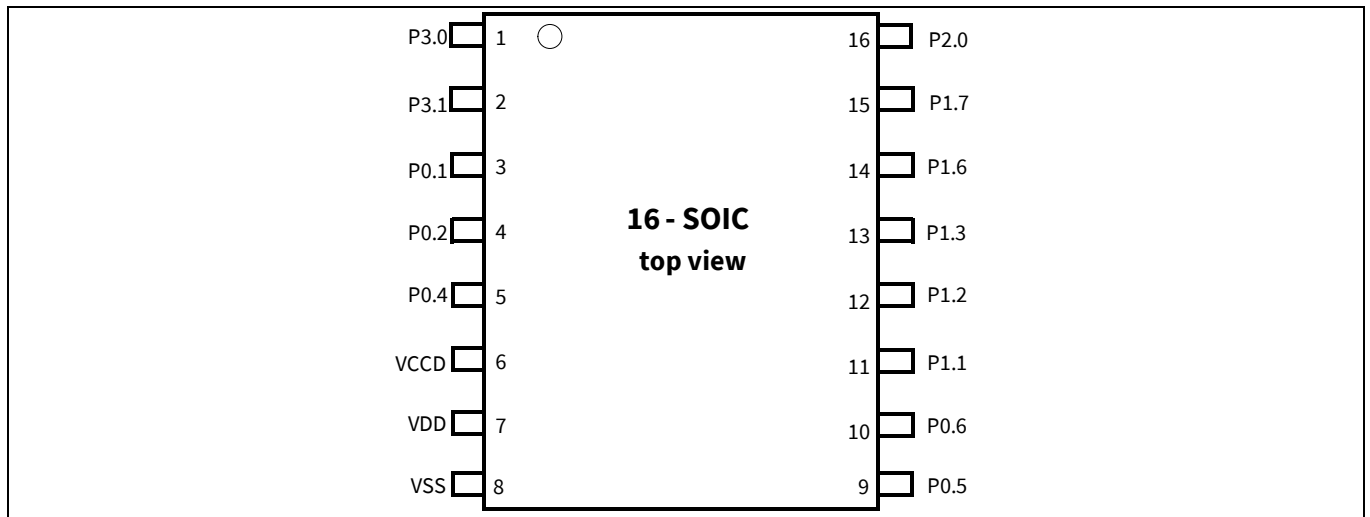

Figure 3 16-pin SOIC pinout

4 Power

Figure 4 through **Figure 5** show the set of power supply pins as implemented for the PSoC™ 4000. The system has one regulator in Active mode for the digital circuitry. There is no analog regulator; the analog circuits run directly from the V_{DD} input. There is a separate regulator for the Deep Sleep mode. The supply voltage range is either $1.8\text{ V} \pm 5\%$ (externally regulated) or 1.8 V to 5.5 V (unregulated externally; regulated internally) with all functions and circuits operating over that range.

The PSoC™ 4000 family allows two distinct modes of power supply operation: Unregulated external supply and regulated external supply.

4.1 Unregulated external supply

In this mode, the PSoC™ 4000 is powered by an external power supply that can be anywhere in the range of 1.8 to 5.5 V . This range is also designed for battery-powered operation. For example, the chip can be powered from a battery system that starts at 3.5 V and works down to 1.8 V . In this mode, the internal regulator of the PSoC™ 4000 supplies the internal logic and the V_{CCD} output of the PSoC™ 4000 must be bypassed to ground via an external capacitor ($0.1\text{ }\mu\text{F}$; X5R ceramic or better).

Bypass capacitors must be used from V_{DD} to ground. The typical practice for systems in this frequency range is to use a capacitor in the $1\text{-}\mu\text{F}$ range, in parallel with a smaller capacitor (for example, $0.1\text{ }\mu\text{F}$). Note that these are simply rules of thumb and that, for critical applications, the PCB layout, lead inductance, and the bypass capacitor parasitic should be simulated to design and obtain optimal bypassing.

Figure 4 shows the bypass scheme (V_{DDIO} is available on the 16-QFN package).

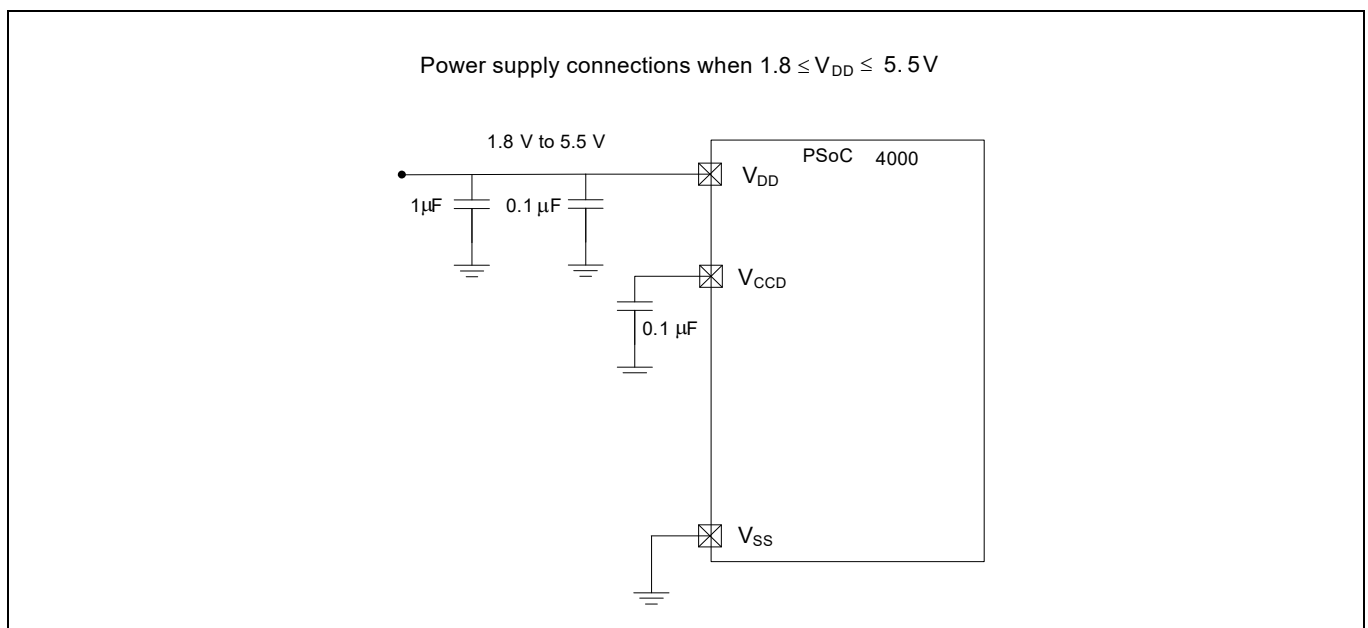

Figure 4 24-pin QFN bypass scheme example - Unregulated external supply

4.2 Regulated external supply

In this mode, the PSoC™ 4000 is powered by an external power supply that must be within the range of 1.71^[1] to 1.89 V; note that this range needs to include the power supply ripple too. In this mode, the V_{DD} and V_{CCD} pins are shorted together and bypassed. The internal regulator is disabled in the firmware.

Figure 5 shows the example for bypass scheme.

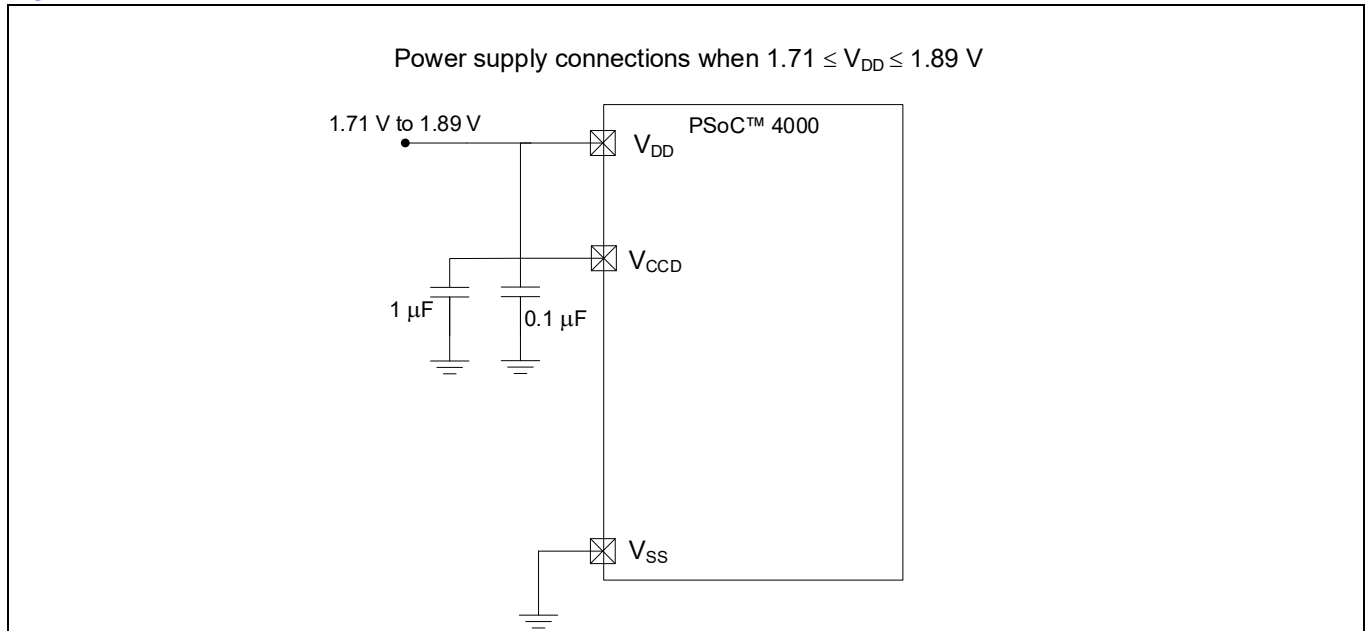

Figure 5 24-pin QFN bypass scheme example - Regulated external supply

Note

1. 1.75 V for E-grade devices.

5 Development support

The PSoC™ 4000 family has a rich set of documentation, development tools, and online resources to assist you during your development process. Visit www.infineon.com/psoc4 to find out more.

5.1 Documentation

A suite of documentation supports the PSoC™ 4000 family to ensure that you can find answers to your questions quickly. This section contains a list of some of the key documents.

Software user guide: A step-by-step guide for using PSoC™ Creator. The software user guide shows you how the PSoC™ Creator build process works in detail, how to use source control with PSoC™ Creator, and much more.

Component datasheets: The flexibility of PSoC™ allows the creation of new peripherals (components) long after the device has gone into production. Component data sheets provide all of the information needed to select and use a particular component, including a functional description, API documentation, example code, and AC/DC specifications.

Application notes: PSoC™ application notes discuss a particular application of PSoC™ in depth; examples include brushless DC motor control and on-chip filtering. Application notes often include example projects in addition to the application note document.

Reference manual: The Reference Manual (RM) contains all the technical detail you need to use a PSoC™ device, including a complete description of all PSoC™ registers. The RM is available in the Documentation section at www.infineon.com/psoc4.

5.2 Online

In addition to print documentation, the PSoC™ forums connect you with fellow PSoC™ users and experts in PSoC™ from around the world, 24 hours a day, 7 days a week.

5.3 Tools

With industry standard cores, programming, and debugging interfaces, the PSoC™ 4000 family is part of a development tool ecosystem. Visit us at www.infineon.com/psoccreator for the latest information on the revolutionary, easy to use PSoC™ Creator IDE, supported third party compilers, programmers, debuggers, and development kits.

6 Electrical Specifications

6.1 Absolute Maximum Ratings

Table 2 Absolute Maximum Ratings^[2]

Spec ID#	Parameter	Description	Min	Typ	Max	Unit	Details/conditions
SID1	V _{DDD_ABS}	Digital supply relative to V _{SS}	-0.5	-	6	V	-
SID2	V _{CCD_ABS}	Direct digital core voltage input relative to V _{SS}	-0.5	-	1.95	V	-
SID3	V _{GPI0_ABS}	GPIO voltage	-0.5	-	V _{DD} + 0.5	V	-
SID4	I _{GPI0_ABS}	Maximum current per GPIO	-25	-	25	mA	-
SID5	I _{GPI0_injection}	GPIO injection current, Max for V _{IH} > V _{DDD} , and Min for V _{IL} < V _{SS}	-0.5	-	0.5	mA	Current injected per pin
BID44	ESD_HBM	Electrostatic discharge human body model	2000	-	-	V	-
BID45	ESD_CDM	Electrostatic discharge charged device model	500	-	-	V	-
BID46	LU	Pin current for latch-up	-140	-	140	mA	-

6.2 Device Level Specifications

All specifications are valid for $-40^{\circ}\text{C} \leq T_A \leq 85^{\circ}\text{C}$ for A grade devices and $-40^{\circ}\text{C} \leq T_A \leq 105^{\circ}\text{C}$ for S grade devices and $-40^{\circ}\text{C} \leq T_A \leq 125^{\circ}\text{C}$ for Grade-E devices, except where noted. Specifications are valid for 1.71 V to 5.5 V, except where noted.

Table 3 DC Specifications

Typical values measured at V_{DD} = 3.3 V and 25°C

Spec ID#	Parameter	Description	Min	Typ	Max	Unit	Details/conditions
SID53	V _{DD}	Power supply input voltage	1.8	-	5.5	V	With regulator enabled
SID255	V _{DD}	Power supply input voltage (V _{CCD} = V _{DD})	1.71	-	1.89	V	Internally unregulated supply
			1.75	-	1.89	V	-40°C ≤ TA ≤ 125°C
SID54	V _{DDIO}	V _{DDIO} domain supply	1.71	-	V _{DD}	V	-
			1.75	-	V _{DD}	V	-40°C ≤ TA ≤ 125°C
SID55	C _{EFC}	External regulator voltage bypass	-	0.1	-	μF	X5R ceramic or better
SID56	C _{EXC}	Power supply bypass capacitor	-	1	-	μF	X5R ceramic or better

Note

- Usage above the absolute maximum conditions listed in [Table 1](#) may cause permanent damage to the device. Exposure to absolute maximum conditions for extended periods of time may affect device reliability. The maximum storage temperature is 150°C in compliance with JEDEC Standard JESD22-A103, high temperature Storage Life. When used below absolute maximum conditions but above normal operating conditions, the device may not operate to specification.

Electrical Specifications

Table 3 DC Specifications (continued)

Typical values measured at $V_{DD} = 3.3\text{ V}$ and 25°C

Spec ID#	Parameter	Description	Min	Typ	Max	Unit	Details/conditions
Active mode, $V_{DD} = 1.8$ to 5.5 V							
SID9	I_{DD5}	Execute from flash; CPU at 6 MHz	–	2.0	2.85	mA	–
SID12	I_{DD8}	Execute from flash; CPU at 12 MHz	–	3.2	3.75	mA	–
SID16	I_{DD11}	Execute from flash; CPU at 16 MHz	–	4.0	4.5	mA	–
Sleep mode, $V_{DD} = 1.71$ to 5.5 V							
SID25	I_{DD20}	I ² C wakeup, WDT on. 6 MHz	–	1.1	–	mA	–
SID25A	I_{DD20A}	I ² C wakeup, WDT on. 12 MHz	–	1.4	–	mA	–
Deep Sleep mode, $V_{DD} = 1.8$ to 3.6 V (Regulator ON)							
SID31	I_{DD26}	I ² C wakeup and WDT ON	–	2.5	8.2	μA	–
Deep Sleep mode, $V_{DD} = 3.6$ to 5.5 V (Regulator ON)							
SID34	I_{DD29}	I ² C wakeup and WDT ON	–	2.5	12	μA	–
Deep Sleep mode, $V_{DD} = V_{CCD} = 1.71$ to 1.89 V (Regulator bypassed)							
SID37	I_{DD32}	I ² C wakeup and WDT ON	–	2.5	9.2	μA	–
XRES current							
SID307	I_{DD_XR}	Supply current while XRES asserted	–	2	5	mA	–

Table 4 AC Specifications

Spec ID#	Parameter	Description	Min	Typ	Max	Unit	Details/conditions
SID48	F_{CPU}	CPU frequency	DC	–	16	MHz	$1.71 \leq V_{DD} \leq 5.5$
SID49 ^[3]	T_{SLEEP}	Wakeup from Sleep mode	–	0	–	μs	–
SID50 ^[3]	$T_{DEEPSLEEP}$	Wakeup from Deep Sleep mode	–	35	–	μs	–

Note

3. Guaranteed by characterization.

6.2.1 GPIO

Table 5 GPIO DC Specifications

Spec ID#	Parameter	Description	Min	Typ	Max	Unit	Details/conditions
SID57	$V_{IH}^{[4]}$	Input voltage high threshold	$0.7 \times V_{DD}$	-	-	V	CMOS Input
SID58	V_{IL}	Input voltage low threshold	-	-	$0.3 \times V_{DD}$	V	CMOS Input
SID241	$V_{IH}^{[4]}$	LVTTL input, $V_{DD} < 2.7$ V	$0.7 \times V_{DD}$	-	-	V	-
SID242	V_{IL}	LVTTL input, $V_{DD} < 2.7$ V	-	-	$0.3 \times V_{DD}$	V	-
SID243	$V_{IH}^{[4]}$	LVTTL input, $V_{DD} \geq 2.7$ V	2.0	-	-	V	-
SID244	V_{IL}	LVTTL input, $V_{DD} \geq 2.7$ V	-	-	0.8	V	-
SID59	V_{OH}	Output voltage high level	$V_{DD} - 0.6$	-	-	V	$I_{OH} = 4$ mA at $3 V_{DD}$
SID60	V_{OH}	Output voltage high level	$V_{DD} - 0.5$	-	-	V	$I_{OH} = 1$ mA at $1.8 V_{DD}$
SID61	V_{OL}	Output voltage low level	-	-	0.6	V	$I_{OL} = 4$ mA at $1.8 V_{DD}$
SID62	V_{OL}	Output voltage low level	-	-	0.6	V	$I_{OL} = 10$ mA at $3 V_{DD}$
SID62A	V_{OL}	Output voltage low level	-	-	0.4	V	$I_{OL} = 3$ mA at $3 V_{DD}$
SID63	R_{PULLUP}	Pull-up resistor	3.5	5.6	8.5	k Ω	-
SID64	$R_{PULLDOWN}$	Pull-down resistor	3.5	5.6	8.5	k Ω	-
SID65	I_{IL}	Input leakage current (absolute value)	-	-	2	nA	25°C, $V_{DD} = 3.0$ V
SID66	C_{IN}	Input capacitance	-	3	7	pF	-
SID67 ^[5]	V_{HYSTTL}	Input hysteresis LVTTL	15	40	-	mV	$V_{DD} \geq 2.7$ V
SID68 ^[5]	$V_{HYSCMOS}$	Input hysteresis CMOS	$0.05 \times V_{DD}$	-	-	mV	$V_{DD} < 4.5$ V
SID68A ^[5]	$V_{HYSCMOS5V5}$	Input hysteresis CMOS	200	-	-	mV	$V_{DD} > 4.5$ V
SID69 ^[5]	I_{DIODE}	Current through protection diode to V_{DD}/V_{SS}	-	-	100	μ A	-
SID69A ^[5]	I_{TOT_GPIO}	Maximum total source or sink chip current	-	-	85	mA	-

Notes

- 4. V_{IH} must not exceed $V_{DD} + 0.2$ V.
- 5. Guaranteed by characterization.

Table 6 GPIO AC specifications

(Guaranteed by Characterization)

Spec ID#	Parameter	Description	Min	Typ	Max	Unit	Details/conditions
SID70	T _{RISEF}	Rise time in Fast Strong mode	2	–	12	ns	3.3 V V _{DDD} , Load = 25 pF
SID71	T _{FALLF}	Fall time in Fast Strong mode	2	–	12	ns	3.3 V V _{DDD} , Load = 25 pF
SID72	T _{RISES}	Rise time in Slow Strong mode	10	–	60	–	3.3 V V _{DDD} , Load = 25 pF
SID73	T _{FALLS}	Fall time in Slow Strong mode	10	–	60	–	3.3 V V _{DDD} , Load = 25 pF
SID74	F _{GPIOUT1}	GPIO F _{OUT} ; 3.3 V ≤ V _{DDD} ≤ 5.5 V. Fast Strong mode.	–	–	16	MHz	90/10%, 25 pF load, 60/40 duty cycle
SID75	F _{GPIOUT2}	GPIO F _{OUT} ; 1.71 V ≤ V _{DDD} ≤ 3.3 V. Fast Strong mode.	–	–	16	MHz	90/10%, 25 pF load, 60/40 duty cycle
SID76	F _{GPIOUT3}	GPIO F _{OUT} ; 3.3 V ≤ V _{DDD} ≤ 5.5 V. Slow Strong mode.	–	–	7	MHz	90/10%, 25 pF load, 60/40 duty cycle
SID245	F _{GPIOUT4}	GPIO F _{OUT} ; 1.71 V ≤ V _{DDD} ≤ 3.3 V. Slow Strong mode.	–	–	3.5	MHz	90/10%, 25 pF load, 60/40 duty cycle
SID246	F _{GPIOIN}	GPIO input operating frequency; 1.71 V ≤ V _{DDD} ≤ 5.5 V	–	–	16	MHz	90/10% V _{IO}

6.2.2 XRES

Table 7 XRES DC specifications

Spec ID#	Parameter	Description	Min	Typ	Max	Unit	Details/conditions
SID77	V _{IH}	Input voltage HIGH threshold	0.7 × V _{DDD}	–	–	V	CMOS Input
SID78	V _{IL}	Input voltage LOW threshold	–	–	0.3 × V _{DDD}	V	CMOS Input
SID79	R _{PULLUP}	Pull-up resistor	3.5	5.6	8.5	kΩ	–
SID80	C _{IN}	Input capacitance	–	3	7	pF	–
SID81 ^[6]	V _{HYSXRES}	Input voltage hysteresis	–	05 × V _{DD}	–	mV	Typical hysteresis is 200 mV for V _{DD} > 4.5V

Table 8 XRES AC Specifications

Spec ID#	Parameter	Description	Min	Typ	Max	Unit	Details/conditions
SID83 ^[6]	T _{RESETWIDTH}	Reset pulse width	5	–	–	μs	–
BID#194 ^[6]	T _{RESETWAKE}	Wake-up time from reset release	–	–	3	ms	–

Note

6. Guaranteed by characterization.

6.3 Analog peripherals

6.3.1 Comparator

Table 9 Comparator DC specifications

Spec ID#	Parameter	Description	Min	Typ	Max	Unit	Details/conditions
SID330 ^[7]	I _{CMP1}	Block current, High Bandwidth mode	–	–	110	μA	–
SID331 ^[7]	I _{CMP2}	Block current, Low-power mode	–	–	85	μA	–
SID332 ^[7]	V _{OFFSET1}	Offset voltage, High Bandwidth mode	–	10	30	mV	–
SID333 ^[7]	V _{OFFSET2}	Offset voltage, Low-power mode	–	10	30	V	–
SID334 ^[7]	Z _{CMP}	DC input impedance of comparator	35	–	–	MΩ	–
SID338 ^[7]	VINP_COMP	Comparator input range	0	–	3.6	V	Max input voltage is lower of 3.6 V or V _{DD}

Table 10 Comparator AC specifications (Guaranteed by characterization)

Spec ID#	Parameter	Description	Min	Typ	Max	Unit	Details/conditions
SID336 ^[7]	T _{COMP1}	Response time High Bandwidth mode, 50-mV overdrive	–	–	90	ns	–
SID337 ^[7]	T _{COMP2}	Response time Low -power mode, 50-mV overdrive	–	–	110	ns	–

Note

7. Guaranteed by characterization.

Electrical Specifications

6.3.2 CSD

Table 11 CSD and IDAC Block Specifications

Spec ID#	Parameter	Description	Min	Typ	Max	Unit	Details/conditions
CSD and IDAC specifications							
SYS.PER#3	VDD_RIPPLE	Max allowed ripple on power supply, DC to 10 MHz	-	-	±50	mV	$V_{DD} > 2\text{ V}$ (with ripple), 25°C T_A , Sensitivity = 0.1 pF
SYS.PER#16	VDD_RIPPLE_1.8	Max allowed ripple on power supply, DC to 10 MHz	-	-	±25	mV	$V_{DD} > 1.75\text{ V}$ (with ripple), 25°C T_A , Parasitic capacitance (C_P) < 20 pF, Sensitivity ≥ 0.4 pF
SID.CSD#15	VREF	Voltage reference for CSD and Comparator	1.1	1.2	1.3	V	-
SID.CSD#16	IDAC1IDD	IDAC1 (8-bits) block current	-	-	1125	µA	-
SID.CSD#17	IDAC2IDD	IDAC2 (7-bits) block current	-	-	1125	µA	-
SID308	V_{CSD}	Voltage range of operation	1.71	-	5.5	V	1.8 V ±5% or 1.8 V to 5.5 V
			1.75	-	5.5	V	-40°C ≤ T_A ≤ 125°C
SID308A	VCOMPIDAC	Voltage compliance range of IDAC	0.8	-	$V_{DD} - 0.8$	V	-
SID309	IDAC1 _{DNL}	DNL for 8-bit resolution	-1	-	1	LSB	-
SID310	IDAC1 _{INL}	INL for 8-bit resolution	-3	-	3	LSB	-
SID311	IDAC2 _{DNL}	DNL for 7-bit resolution	-1	-	1	LSB	-
SID312	IDAC2 _{INL}	INL for 7-bit resolution	-3	-	3	LSB	-
SID313	SNR	Ratio of counts of finger to noise. Guaranteed by characterization	5	-	-	Ratio	Capacitance range of 9 to 35 pF, 0.1 pF sensitivity
SID314	IDAC1 _{CRT1}	Output current of IDAC1 (8 bits) in high range	-	612	-	µA	-
SID314A	IDAC1 _{CRT2}	Output current of IDAC1(8 bits) in low range	-	306	-	µA	-
SID315	IDAC2 _{CRT1}	Output current of IDAC2 (7 bits) in high range	-	304.8	-	µA	-
SID315A	IDAC2 _{CRT2}	Output current of IDAC2 (7 bits) in low range	-	152.4	-	µA	-
SID320	IDAC _{OFFSET}	All zeroes input	-	-	±1	LSB	-
SID321	IDAC _{GAIN}	Full-scale error less offset	-	-	±10	%	-
SID322	IDAC _{MISMATCH}	Mismatch between IDACs	-	-	7	LSB	-
SID323	IDAC _{SET8}	Settling time to 0.5 LSB for 8-bit IDAC	-	-	10	µs	Full-scale transition. No external load.
SID324	IDAC _{SET7}	Settling time to 0.5 LSB for 7-bit IDAC	-	-	10	µs	Full-scale transition. No external load.
SID325	CMOD	External modulator capacitor	-	2.2	-	nF	5-V rating, X7R or NP0 cap.

6.4 Digital peripherals

6.4.1 Timer counter pulse-width modulator (TCPWM)

Table 12 TCPWM specifications

Spec ID	Parameter	Description	Min	Typ	Max	Unit	Details/conditions
SID.TCPWM.1	ITCPWM1	Block current consumption at 3 MHz	-	-	45	μA	All modes (TCPWM)
SID.TCPWM.2	ITCPWM2	Block current consumption at 8 MHz	-	-	145	μA	All modes (TCPWM)
SID.TCPWM.2A	ITCPWM3	Block current consumption at 16 MHz	-	-	160	μA	All modes (TCPWM)
SID.TCPWM.3	TCPWM _{FREQ}	Operating frequency	-	-	F _c	MHz	F _c max = CLK_SYS. Maximum = 16 MHz
SID.TCPWM.4	TPWM _{ENEXT}	Input trigger pulse width	2/F _c	-	-	ns	For all trigger events ^[8]
SID.TCPWM.5	TPWM _{EXT}	Output trigger pulse widths	2/F _c	-	-	ns	Minimum possible width of Overflow, Underflow, and CC (Counter equals compare value) outputs
SID.TCPWM.5A	TC _{RES}	Resolution of counter	1/F _c	-	-	ns	Minimum time between successive counts
SID.TCPWM.5B	PWM _{RES}	PWM resolution	1/F _c	-	-	ns	Minimum pulse width of PWM Output
SID.TCPWM.5C	Q _{RES}	Quadrature inputs resolution	1/F _c	-	-	ns	Minimum pulse width between Quadrature phase inputs.

6.4.2 I²C

Table 13 Fixed I²C DC specifications^[8]

Spec ID	Parameter	Description	Min	Typ	Max	Unit	Details/conditions
SID149	I _{I2C1}	Block current consumption at 100 kHz	-	-	25	μA	-
SID150	I _{I2C2}	Block current consumption at 400 kHz	-	-	135	μA	-
SID152	I _{I2C4}	I ² C enabled in Deep Sleep mode	-	-	2.5	μA	-

Table 14 Fixed I²C AC specifications^[8]

Spec ID	Parameter	Description	Min	Typ	Max	Unit	Details/conditions
SID153	F _{I2C1}	Bit Rate	-	-	400	Kbps	-

Note

8. Guaranteed by characterization.

6.5 Memory

Table 15 Flash DC specifications

Spec ID	Parameter	Description	Min	Typ	Max	Unit	Details/conditions
SID173	V _{PE}	Erase and program voltage	1.71	–	5.5	V	–
			1.75	–	5.5	V	–40°C ≤ TA ≤ 125°C

Table 16 Flash AC specifications

Spec ID	Parameter	Description	Min	Typ	Max	Unit	Details/conditions
SID174	T _{ROWWRITE} ^[9]	Row (block) write time (erase and program)	–	–	20	ms	Row (block) = 128 bytes
SID175	T _{ROWERASE} ^[9]	Row erase time	–	–	13	ms	–
SID176	T _{ROWPROGRAM} ^[9]	Row program time after erase	–	–	7	ms	–
SID178	T _{BULKERASE} ^[9]	Bulk erase time (16 KB)	–	–	15	ms	–
SID180 ^[10]	T _{DEVPROG} ^[9]	Total device program time	–	–	7.5	seconds	–
SID181 ^[10]	F _{END}	Flash endurance	100 K	–	–	cycles	–
SID182 ^[10]	F _{RET}	Flash retention. T _A ≤ 55°C, 100 K P/E cycles	20 ^[11]	–	–	years	–
SID182A ^[10]	–	Flash retention. T _A ≤ 85°C, 10 K P/E cycles	10 ^[12]	–	–	years	–

6.6 System resources

6.6.1 Power-on reset (POR)

Table 17 Power-on reset (PRES)

Spec ID	Parameter	Description	Min	Typ	Max	Unit	Details/conditions
SID.CLK#6	SR_POWER	Power supply slew rate	1	–	67	V/ms	On power-up and power-down
SID185 ^[10]	V _{RISEIPOR}	Rising trip voltage	0.80	–	1.5	V	–
SID186 ^[10]	V _{FALLIPOR}	Falling trip voltage	0.70	–	1.4	V	–

Table 18 Brown-out detect (BOD) for V_{CCD}

Spec ID	Parameter	Description	Min	Typ	Max	Unit	Details/conditions
SID190 ^[10]	V _{FALLPPOR}	BOD trip voltage in active and sleep modes	1.48	–	1.62	V	–
SID192 ^[10]	V _{FALLDPSLP}	BOD trip voltage in Deep Sleep	1.11	–	1.5	V	–

Notes

9. It can take as much as 20 milliseconds to write to flash. During this time the device should not be Reset, or Flash operations will be interrupted and cannot be relied on to have completed. Reset sources include the XRES pin, software resets, CPU lockup states and privilege violations, improper power supply levels, and watchdogs. Make certain that these are not inadvertently activated.

10. Guaranteed by characterization.

11. Infineon provides a retention calculator to calculate the retention lifetime based on customers' individual temperature profiles for operation over the –40°C to +125°C ambient temperature range. Contact

<https://www.infineon.com/support>.

6.6.2 SWD interface

Table 19 SWD interface specifications

Spec ID	Parameter	Description	Min	Typ	Max	Unit	Details/conditions
SID213	F_SWDCLK1	$3.3\text{ V} \leq V_{DD} \leq 5.5\text{ V}$	-	-	14	MHz	SWDCLK \leq 1/3 CPU clock frequency
SID214	F_SWDCLK2	$1.71\text{ V} \leq V_{DD} \leq 3.3\text{ V}$	-	-	7	MHz	SWDCLK \leq 1/3 CPU clock frequency
SID215 ^[13]	T_SWDI_SETUP	$T = 1/f\text{ SWDCLK}$	$0.25 \times T$	-	-	ns	-
SID216 ^[13]	T_SWDI_HOLD	$T = 1/f\text{ SWDCLK}$	$0.25 \times T$	-	-	ns	-
SID217 ^[13]	T_SWDO_VALID	$T = 1/f\text{ SWDCLK}$	-	-	$0.5 \times T$	ns	-
SID217A ^[13]	T_SWDO_HOLD	$T = 1/f\text{ SWDCLK}$	1	-	-	ns	-

6.6.3 Internal main oscillator

Table 20 IMO DC specifications

(Guaranteed by Design)

Spec ID	Parameter	Description	Min	Typ	Max	Unit	Details/conditions
SID218	I _{IMO1}	IMO operating current at 48 MHz	-	-	250	μA	$-40^\circ\text{C} \leq T_A \leq 85^\circ\text{C}$
SID219	I _{IMO2}	IMO operating current at 24 MHz	-	-	180	μA	$-40^\circ\text{C} \leq T_A \leq 85^\circ\text{C}$

Table 21 IMO AC specifications

Spec ID	Parameter	Description	Min	Typ	Max	Unit	Details/conditions
SID223	F _{IMOTOL1}	Frequency variation at 24 and 32 MHz (trimmed)	-	-	±2	%	$2\text{ V} \leq V_{DD} \leq 5.5\text{ V}$, and $-25^\circ\text{C} \leq T_A \leq 85^\circ\text{C}$
SID223A	F _{IMOTOLVCCD}	Frequency variation (trimmed)	-	-	±4	%	All
SID226	T _{STARTIMO}	IMO startup time	-	-	7	μs	-
SID228	T _{JITRMSIMO2}	RMS jitter at 24 MHz	-	145	-	ps	-

Note

13. Guaranteed by characterization.

Electrical Specifications

6.6.4 Internal low-speed oscillator

Table 22 ILO DC specifications

(Guaranteed by Design)

Spec ID	Parameter	Description	Min	Typ	Max	Unit	Details/conditions
SID231 ^[14]	I _{ILO1}	ILO operating current	–	0.3	1.05	µA	-40°C ≤ TA ≤ 85°C
SID233 ^[14]	I _{ILOLEAK}	ILO leakage current	–	2	15	nA	-40°C ≤ TA ≤ 85°C

Table 23 ILO AC Specifications

Spec ID	Parameter	Description	Min	Typ	Max	Unit	Details/conditions
SID234 ^[14]	T _{STARTILO1}	ILO startup time	–	–	2	ms	-40°C ≤ TA ≤ 85°C
SID236 ^[14]	T _{ILODUTY}	ILO duty cycle	40	50	60	%	-40°C ≤ TA ≤ 85°C
SID237	F _{ILOTRIM1}	ILO frequency range	20	40	80	kHz	-40°C ≤ TA ≤ 85°C

6.6.5 External clock

Table 24 External clock specifications

Spec ID	Parameter	Description	Min	Typ	Max	Unit	Details/conditions
SID305 ^[14]	ExtClkFreq	External clock input frequency	0	–	16	MHz	–
SID306 ^[14]	ExtClkDuty	Duty cycle; measured at V _{DD/2}	45	–	55	%	–

6.6.6 Block

Table 25 Block specs

Spec ID	Parameter	Description	Min	Typ	Max	Unit	Details/conditions
SID262 ^[14]	T _{CLKSWITCH}	System clock source switching time	3	–	4	Periods	–

Note

14. Guaranteed by characterization.

7 Ordering information

The PSoC™ 4000 part numbers and features are listed in the following table.

MPN	Features									Package		Operating temperature		
	Max CPU speed (MHz)	Flash (KB)	SRAM (KB)	CAPSENSE™	7-bit IDAC	8-bit IDAC	Comparators	TCPWM Blocks	SCB (I2C)	16-SOIC	24-QFN	-40 to +85°C	-40 to +105°C	-40 to +125°C
CY8C4014SXA-421Z	16	16	2	4	1	1	1	1	1	4	-	4	-	-
CY8C4014LQA-422Z	16	16	2	4	1	1	1	1	1	-	4	4	-	-
CY8C4014SXS-421Z	16	16	2	4	1	1	1	1	1	4	-	-	4	-
CY8C4014LQS-422Z	16	16	2	4	1	1	1	1	1	-	4	-	4	-
CY8C4014SXE-421Z ^[15]	16	16	2	4	1	1	1	1	1	4	-	-	-	4
CY8C4014LQE-422Z	16	16	2	4	1	1	1	1	1	-	4	-	-	4
CY8C4014LQA-422	16	16	2	4	1	1	1	1	1	-	4	-	4	-
CY8C4014LQS-422	16	16	2	4	1	1	1	1	1	-	4	-	4	-

7.1 Part numbering conventions

PSoC™ 4 devices follow the part numbering convention described in the following table. All fields are single-character alphanumeric (0, 1, 2, ..., 9, A,B, ..., Z) unless stated otherwise.

The part numbers are of the form CY8C4ABCDEF-XYZ where the fields are defined as follows.

Examples

4 : PSoC™ 4

0 : 4000 family

1 : 16 MHz

4 : 16 KB

LQ : QFN
 SX : SOIC

A: AEC-Q100, -40°C to +85°C

S: AEC-Q100, -40°C to +105°C

E: AEC-Q100, -40°C to +125°C

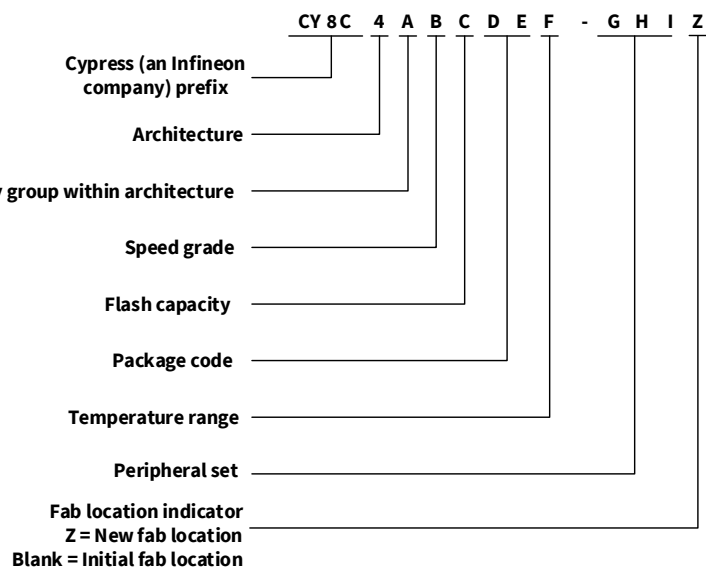

Ordering information

The field values are listed in the following table:

Field	Description	Values	Meaning
CY8C	Cypress (an Infineon company) prefix	-	-
4	Architecture	4	PSoC™ 4
A	Family	0	4000 family
B	CPU speed	1	16 MHz
		4	48 MHz
C	Flash capacity	3	8 KB
		4	16 KB
		5	32 KB
		6	64 KB
		7	128 KB
DE	Package code	SX	SOIC
		LQ	QFN
F	Temperature range	A/S	Automotive
GHI	Attributes code	000-999	Code of feature set in specific family
Z	Fab location change	-	-

Note

15.Contact Infineon for availability of this device.

Packaging

8 Packaging

Table 26 Package list

Spec ID#	Package	Description
BID#26	24-pin QFN	24-pin 4 × 4 × 0.6 mm QFN with 0.5-mm pitch
BID#40	16-pin SOIC	16-pin SOIC (150 Mil)

Table 27 Package characteristics

Parameter	Description	Conditions	Min	Typ	Max	Unit
T _A	Operating ambient temperature	For A grade devices	-40	25.00	85	°C
T _A	Operating ambient temperature	For S grade devices	-40	25.00	105	°C
T _A	Operating ambient temperature	For E grade devices	-40	25.00	125	°C
T _J	Operating junction temperature	For A grade devices	-40	-	100	°C
T _J	Operating junction temperature	For S grade devices	-40	-	120	°C
T _J	Operating junction temperature	For E grade devices	-40	-	140	°C
T _{JA}	Package θ _{JA} (24-pin QFN)	-	-	38.01	-	°C/W
T _{JA}	Package θ _{JA} (16-pin SOIC)	-	-	142.14	-	°C/W

Table 28 Solder reflow peak temperature

Package	Maximum peak temperature	Maximum time at peak temperature
All	260°C	30 seconds

Table 29 Package moisture sensitivity level (MSL), IPC/JEDEC J-STD-020

Package	MSL
All	MSL 3

8.1 Package outline drawings

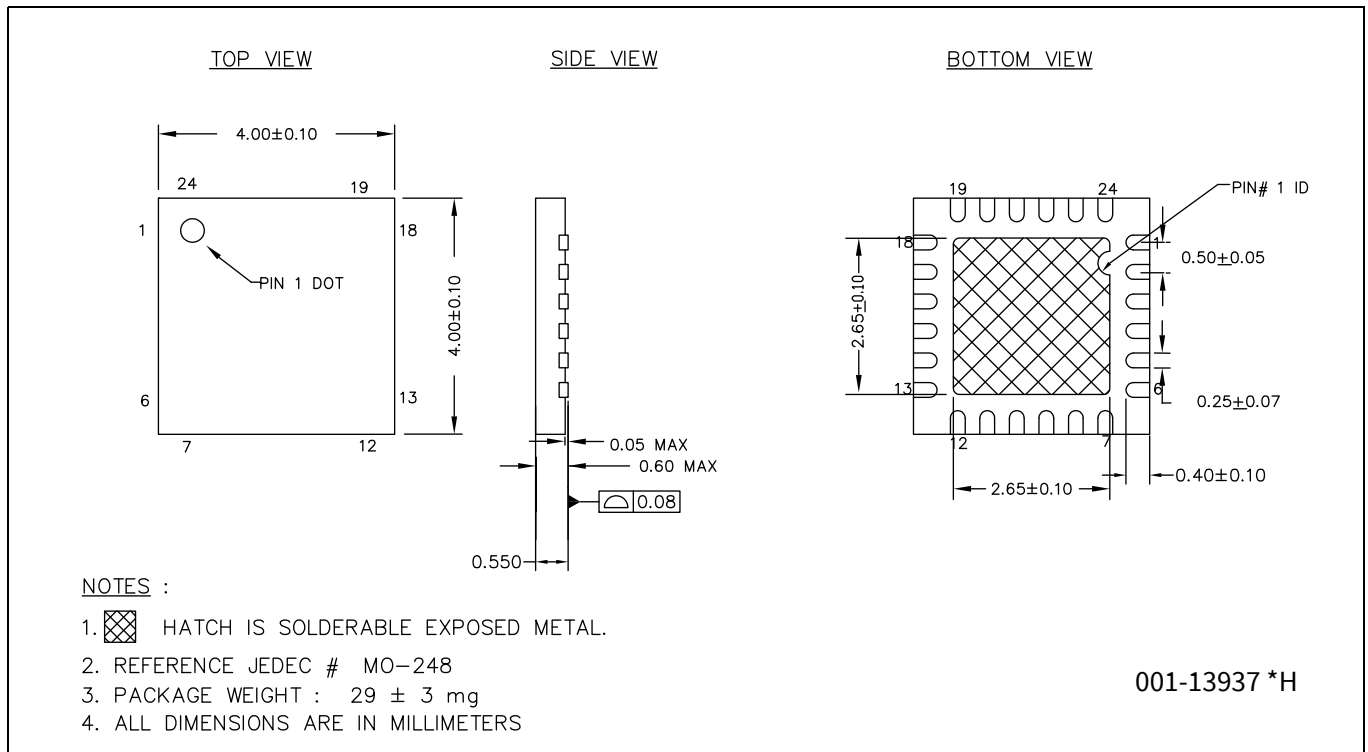

Figure 6 24-pin QFN ((4 × 4 × 0.55 mm) 2.65 × 2.65 E-Pad (Sawn)) package outline (PG-V QFN-24-800)

The center pad on the QFN package should be connected to ground (VSS) for best mechanical, thermal, and electrical performance. If not connected to ground, it should be electrically floating and not connected to any other signal.

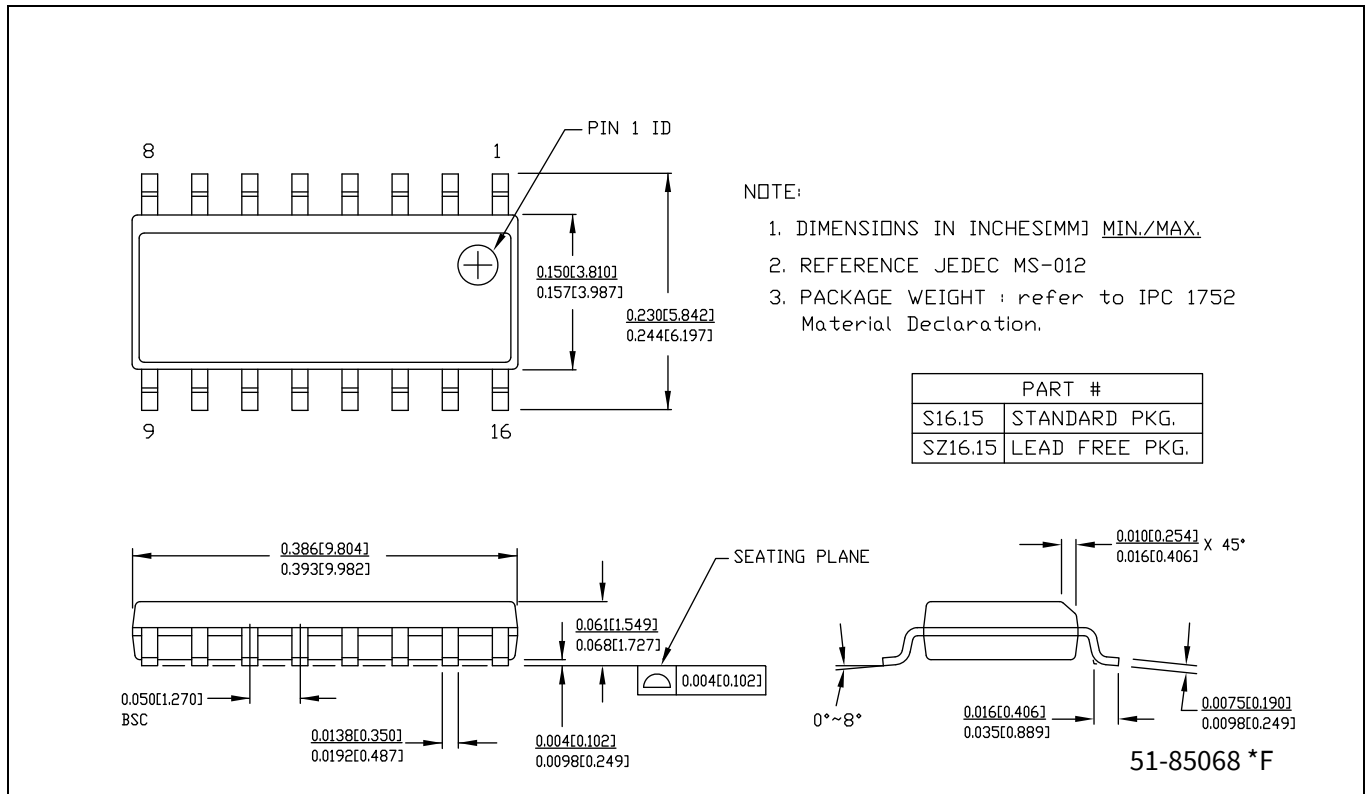

Figure 7 16-pin SOIC (150 Mils) package outline (PG-DSO-16-800)

9 Acronyms

Table 30 Acronyms used in this document

Acronym	Description
abus	analog local bus
ADC	analog-to-digital converter
AG	analog global
AHB	AMBA (advanced microcontroller bus architecture) high-performance bus, an Arm® data transfer bus
ALU	arithmetic logic unit
AMUXBUS	analog multiplexer bus
API	application programming interface
APSR	application program status register
Arm®	advanced RISC machine, a CPU architecture
ATM	automatic thump mode
BW	bandwidth
CAN	Controller Area Network, a communications protocol
CMRR	common-mode rejection ratio
CPU	central processing unit
CRC	cyclic redundancy check, an error-checking protocol
DAC	digital-to-analog converter, see also IDAC, VDAC
DFB	digital filter block
DIO	digital input/output, GPIO with only digital capabilities, no analog. See GPIO.
DMIPS	Dhrystone million instructions per second
DMA	direct memory access, see also TD
DNL	differential nonlinearity, see also INL
DNU	do not use
DR	port write data registers
DSI	digital system interconnect
DWT	data watchpoint and trace
ECC	error correcting code
ECO	external crystal oscillator
EEPROM	electrically erasable programmable read-only memory
EMI	electromagnetic interference
EMIF	external memory interface
EOC	end of conversion
EOF	end of frame
EPSR	Execution Program Status register
ESD	electrostatic discharge
ETM	embedded trace macrocell
FIR	finite impulse response, see also IIR

Table 30 Acronyms used in this document (continued)

Acronym	Description
FPB	flash patch and breakpoint
FS	full-speed
GPIO	General-purpose Input/Output, applies to a PSoC™ pin
HVI	high-voltage interrupt, see also LVI, LVD
IC	integrated circuit
IDAC	current DAC, see also DAC, VDAC
IDE	integrated development environment
I ² C, or IIC	Inter-Integrated Circuit, a communications protocol
IIR	infinite impulse response, see also FIR
ILO	internal low-speed oscillator, see also IMO
IMO	internal main oscillator, see also ILO
INL	integral nonlinearity, see also DNL
I/O	input/output, see also GPIO, DIO, SIO, USBIO
IPOR	initial power-on reset
IPSR	interrupt program status register
IRQ	interrupt request
ITM	instrumentation trace macrocell
LCD	liquid crystal display
LIN	Local Interconnect Network, a communications protocol.
LR	link register
LUT	lookup table
LVD	low-voltage detect, see also LVI
LVI	low-voltage interrupt, see also HVI
LVTTL	low-voltage transistor-transistor logic
MAC	multiply-accumulate
MCU	microcontroller unit
MISO	master-in slave-out
NC	no connect
NMI	nonmaskable interrupt
NRZ	non-return-to-zero
NVIC	nested vectored interrupt controller
NVL	nonvolatile latch, see also WOL
opamp	operational amplifier
PAL	programmable array logic, see also PLD
PC	program counter
PCB	printed circuit board
PGA	programmable gain amplifier
PHUB	peripheral hub

Acronyms

Table 30 Acronyms used in this document (continued)

Acronym	Description
PHY	Physical Layer
PICU	port interrupt control unit
PLA	programmable logic array
PLD	programmable logic device, see also PAL
PLL	phase-locked loop
PMDD	package material declaration data sheet
POR	power-on reset
PRES	precise power-on reset
PRS	pseudo random sequence
PS	Port Read Data register
PSoC™	Programmable System-on-Chip
PSRR	power supply rejection ratio
PWM	pulse-width modulator
RAM	random-access memory
RISC	reduced-instruction-set computing
RMS	root-mean-square
RTC	real-time clock
RTL	register transfer language
RTR	remote transmission request
RX	receive
SAR	successive approximation register
SC/CT	switched capacitor/continuous time
SCL	I ² C serial clock
SDA	I ² C serial data
S/H	sample and hold
SINAD	signal to noise and distortion ratio
SIO	special input/output, GPIO with advanced features. See GPIO.
SOC	start of conversion
SOF	start of frame
SPI	Serial Peripheral Interface, a communications protocol
SR	slew rate
SRAM	static random access memory
SRES	software reset
SWD	serial wire debug, a test protocol
SWV	single-wire viewer
TD	transaction descriptor, see also DMA
THD	total harmonic distortion
TIA	transimpedance amplifier

Table 30 **Acronyms used in this document** *(continued)*

Acronym	Description
RM	reference manual
TTL	transistor-transistor logic
TX	transmit
UART	Universal Asynchronous Transmitter Receiver, a communications protocol
UDB	universal digital block
USB	Universal Serial Bus
USBIO	USB input/output, PSoC™ pins used to connect to a USB port
VDAC	voltage DAC, see also DAC, IDAC
WDT	watchdog timer
WOL	write once latch, see also NVL
WRES	watchdog timer reset
XRES	external reset I/O pin
XTAL	crystal

10 Document conventions

10.1 Units of measure

Table 31 Units of measure

Symbol	Unit of measure
°C	degrees celsius
dB	decibel
fF	femto farad
Hz	hertz
KB	1024 bytes
kbps	kilobits per second
Khr	kilohour
kHz	kilohertz
kΩ	kilo ohm
ksps	kilosamples per second
LSB	least significant bit
Mbps	megabits per second
MHz	megahertz
MΩ	mega-ohm
Msp	megasamples per second
μA	microampere
μF	microfarad
μH	microhenry
μs	microsecond
μV	microvolt
μW	microwatt
mA	milliampere
ms	millisecond
mV	millivolt
nA	nanoampere
ns	nanosecond
nV	nanovolt
W	ohm
pF	picofarad
ppm	parts per million
ps	picosecond
s	second
sps	samples per second
sqrtHz	square root of hertz
V	volt
W	watt

Revision history

Document revision	Date	Description of changes
*M	2023-08-08	Added part numbers: CY8C4014LQA-422 and CY8C4014LQS-422 in the “ Ordering information ” on page 24. Updated “ Block diagram ” on page 2. Added the IFX Package name for the Figure 6 and Figure 7 .

Trademarks

All referenced product or service names and trademarks are the property of their respective owners.

Edition 2023-08-08

Published by

**Infineon Technologies AG
81726 Munich, Germany**

**© 2023 Infineon Technologies AG.
All Rights Reserved.**

Do you have a question about this document?

Email:

erratum@infineon.com

Document reference

001-92145 Rev. *M

IMPORTANT NOTICE

The information given in this document shall in no event be regarded as a guarantee of conditions or characteristics ("Beschaffenheitsgarantie").

With respect to any examples, hints or any typical values stated herein and/or any information regarding the application of the product, Infineon Technologies hereby disclaims any and all warranties and liabilities of any kind, including without limitation warranties of non-infringement of intellectual property rights of any third party.

In addition, any information given in this document is subject to customer's compliance with its obligations stated in this document and any applicable legal requirements, norms and standards concerning customer's products and any use of the product of Infineon Technologies in customer's applications.

The data contained in this document is exclusively intended for technically trained staff. It is the responsibility of customer's technical departments to evaluate the suitability of the product for the intended application and the completeness of the product information given in this document with respect to such application.

WARNINGS

Due to technical requirements products may contain dangerous substances. For information on the types in question please contact your nearest Infineon Technologies office.

Except as otherwise explicitly approved by Infineon Technologies in a written document signed by authorized representatives of Infineon Technologies, Infineon Technologies' products may not be used in any applications where a failure of the product or any consequences of the use thereof can reasonably be expected to result in personal injury.

Looking for pricing, stock, or lifecycle information?

Click below to explore more details on WIN SOURCE:

- [View CY8C4014LQS-422 on WIN SOURCE](#)
- [Cypress Semiconductor Corp Information](#)

Optimize Your Supply Chain with WIN SOURCE Solutions

- ✓ Global Sourcing Solution
- ✓ Obsolete Management
- ✓ Cost Control Management
- ✓ Shortage Management
- ✓ Alternative Solution
- ✓ Excess Inventory Management