

ABSOLUTE MAXIMUM RATINGS⁽¹⁾

AV _{DD} to GND	-0.3V to +6V
Digital Input Voltage to GND	-0.3V to +AV _{DD} + 0.3V
V _{OUTA} to V _{OUTD} to GND	-0.3V to + AV _{DD} + 0.3V
Operating Temperature Range	-40°C to +105°C
Storage Temperature Range	-65°C to +150°C
Junction Temperature Range (T _J max)	+150°C
Power Dissipation	(T _J max - T _A)/θ _{JA}
θ _{JA} Thermal Impedance	118°C/W
θ _{JC} Thermal Impedance	29°C/W
Lead Temperature, Soldering:	
Vapor Phase (60s)	+215°C
Infrared (15s)	+220°C

NOTE: (1) Stresses above those listed under "Absolute Maximum Ratings" may cause permanent damage to the device. Exposure to absolute maximum conditions for extended periods may affect device reliability.



ELECTROSTATIC DISCHARGE SENSITIVITY

This integrated circuit can be damaged by ESD. Texas Instruments recommends that all integrated circuits be handled with appropriate precautions. Failure to observe proper handling and installation procedures can cause damage.

ESD damage can range from subtle performance degradation to complete device failure. Precision integrated circuits may be more susceptible to damage because very small parametric changes could cause the device not to meet its published specifications.

PACKAGE/ORDERING INFORMATION

PRODUCT	PACKAGE-LEAD	PACKAGE DESIGNATOR ⁽¹⁾	SPECIFICATION TEMPERATURE RANGE	PACKAGE MARKING	ORDERING NUMBER	TRANSPORT MEDIA, QUANTITY
DAC8534 "	TSSOP-16 "	PW "	-40°C to +105°C "	D8534I "	DAC8534IPW DAC8534IPWR	Tube, 90 Tape and Reel, 2000

NOTE: (1) For the most current specifications and package information, refer to our web site at www.ti.com.

ELECTRICAL CHARACTERISTICS

AV_{DD} = +2.7V to +5.5V, -40°C to +105°C, unless otherwise specified.

PARAMETER	CONDITIONS	DAC8534			UNITS	
		MIN	TYP	MAX		
STATIC PERFORMANCE⁽¹⁾						
Resolution	16-Bit Monotonic	16			Bits	
Relative Accuracy				±0.0987	% of FSR	
Differential Nonlinearity			0.25	±1	LSB	
Zero-Scale Error			+5	+20	mV	
Zero-Scale Error Drift			±7		μV/°C	
Full-Scale Error			-0.15	-1.0	% of FSR	
Gain Error				±1.0	% of FSR	
Gain Temperature Coefficient	R _L = 2kΩ, C _L = 200pF		±3		ppm of FSR/°C	
Channel-to-Channel Matching			8		mV	
PSRR			0.75		mV/V	
OUTPUT CHARACTERISTICS⁽²⁾						
Output Voltage Range	To ±0.003% FSR 0200 _H to FD00 _H R _L = 2kΩ; 0pF < C _L < 200pF R _L = 2kΩ; C _L = 500pF	0		V _{REFH}	V	
Output Voltage Settling Time				8	10	μs
Slew Rate	R _L = ∞ R _L = 2kΩ		12		μs	
Capacitive Load Stability			1		V/μs	
			470		pF	
Code Change Glitch Impulse	1LSB Change Around Major Carry		1000		pF	
Digital Feedthrough			20		nV-s	
DC Crosstalk	1kHz sine Wave		0.5		nV-s	
AC Crosstalk			0.25		LSB	
DC Output Impedance			-100	-96		dB
Short-Circuit Current			1			Ω
Power-Up Time	AV _{DD} = +5V		50		mA	
	AV _{DD} = +3V		20		mA	
	Coming Out of Power-Down Mode AV _{DD} = +5V		2.5		μs	
	Coming Out of Power-Down Mode AV _{DD} = +3V		5		μs	
AC PERFORMANCE	BW = 20kHz, AV _{DD} = 5V F _{OUT} = 1kHz					
SNR (1st 19 Harmonics Removed)			94		dB	
THD			67		dB	
SFDR			69		dB	
SINAD			65		dB	

NOTES: (1) Linearity calculated using a reduced code range of 485 to 64714; output unloaded. (2) Ensured by design and characterization, not production tested.

ELECTRICAL CHARACTERISTICS (Cont.)

$AV_{DD} = +2.7V$ to $+5.5V$, $-40^{\circ}C$ to $+105^{\circ}C$, unless otherwise specified.

PARAMETER	CONDITIONS	DAC8534			UNITS
		MIN	TYP	MAX	
REFERENCE INPUT					
Reference Current	$V_{REF} = AV_{DD} = +5V$		135	180	μA
	$V_{REF} = AV_{DD} = +3V$		80	120	μA
Reference Input Range		0		AV_{DD}	V
Reference Input Impedance			37		$k\Omega$
LOGIC INPUTS (2)					
Input Current	$IOV_{DD} = +5V$			± 1	μA
V_{INL} , Input LOW Voltage	$IOV_{DD} = +3V$			0.8	V
V_{INL} , Input LOW Voltage	$IOV_{DD} = +3V$			0.6	V
V_{INH} , Input HIGH Voltage	$IOV_{DD} = +5V$	2.4			V
V_{INH} , Input HIGH Voltage	$IOV_{DD} = +3V$	2.1			V
Pin Capacitance				3	pF
POWER REQUIREMENTS					
AV_{DD}		2.7		5.5	V
IOV_{DD}		2.7		5.5	V
AI_{DD} (normal mode)	DAC Active and Excluding Load Current				
IOI_{DD}			10	20	μA
$AI_{DD} = +3.6V$ to $+5.5V$	$V_{IH} = IOV_{DD}$ and $V_{IL} = GND$		0.95	1.6	mA
$AI_{DD} = +2.7V$ to $+3.6V$	$V_{IH} = IOV_{DD}$ and $V_{IL} = GND$		0.9	1.5	mA
AI_{DD} (all power-down modes)					
$AI_{DD} = +3.6V$ to $+5.5V$	$V_{IH} = IOV_{DD}$ and $V_{IL} = GND$		0.8	1	μA
$AI_{DD} = +2.7V$ to $+3.6V$	$V_{IH} = IOV_{DD}$ and $V_{IL} = GND$		0.05	1	μA
POWER EFFICIENCY					
I_{OUT}/I_{DD}	$I_{LOAD} = 2mA$, $AV_{DD} = +5V$		89		%
TEMPERATURE RANGE					
Specified Performance		-40		+105	$^{\circ}C$

NOTES: (1) Linearity calculated using a reduced code range of 485 to 64714; output unloaded. (2) Ensured by design and characterization, not production tested.

PIN CONFIGURATION

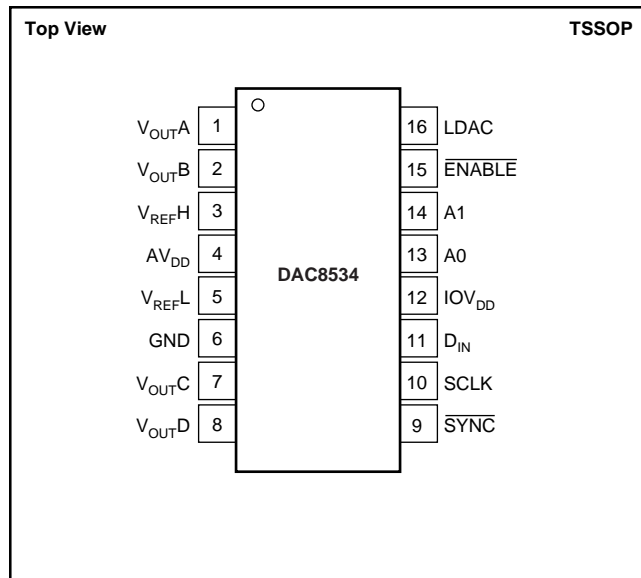

PIN DESCRIPTIONS

PIN	NAME	DESCRIPTION
1	V_{OUTA}	Analog output voltage from DAC A.
2	V_{OUTB}	Analog output voltage from DAC B.
2	V_{REFH}	Positive reference voltage input.
4	AV_{DD}	Power supply input, $+2.7V$ to $+5.5V$.
5	V_{REFL}	Negative reference voltage input.
6	GND	Ground reference point for all circuitry on the part.
7	V_{OUTC}	Analog output voltage from DAC C.
8	V_{OUTD}	Analog output voltage from DAC D.
9	SYNC	Level-triggered control input (active LOW). This is the frame synchronization signal for the input data. When SYNC goes LOW, it enables the input shift register and data is transferred in on the falling edges of the following clocks. The DAC is updated following the 24th clock (unless SYNC is taken HIGH before this edge in which case the rising edge of SYNC acts as an interrupt and the write sequence is ignored by the DAC8534).
10	SCLK	Serial Clock Input. Data can be transferred at rates up to 30MHz.
11	D_{IN}	Serial Data Input. Data is clocked into the 24-bit input shift register on each falling edge of the serial clock input.
12	IOV_{DD}	Digital Input-Output Power Supply
13	A0	Address 0 — sets device address, see Table II.
14	A1	Address 1 — sets device address, see Table II.
15	ENABLE	Active LOW, ENABLE LOW connects the SPI interface to the serial port.
16	LDAC	Load DACs, rising edge triggered loads all DAC registers.

TIMING CHARACTERISTICS(1, 2)

AV_{DD} = +2.7V to +5.5V; all specifications -40°C to +105°C unless otherwise noted.

PARAMETER	DESCRIPTION	CONDITIONS	DAC8534			UNITS
			MIN	TYP	MAX	
t ₁ ⁽³⁾	SCLK Cycle Time	IOV _{DD} = AV _{DD} = 2.7V to 3.6V	50			ns
		IOV _{DD} = AV _{DD} = 3.6V to 5.5V	33			ns
t ₂	SCLK HIGH Time	IOV _{DD} = AV _{DD} = 2.7V to 3.6V	26			ns
		IOV _{DD} = AV _{DD} = 3.6V to 5.5V	15			ns
t ₃	SCLK LOW Time	IOV _{DD} = AV _{DD} = 2.7V to 3.6V	22.5			ns
		IOV _{DD} = AV _{DD} = 3.6V to 5.5V	13			ns
t ₄	SYNC Falling Edge to SCLK Rising Edge Setup Time	IOV _{DD} = AV _{DD} = 2.7V to 3.6V	0			ns
		IOV _{DD} = AV _{DD} = 3.6V to 5.5V	0			ns
t ₅	Data Setup Time	IOV _{DD} = AV _{DD} = 2.7V to 3.6V	5			ns
		IOV _{DD} = AV _{DD} = 3.6V to 5.5V	5			ns
t ₆	Data Hold Time	IOV _{DD} = AV _{DD} = 2.7V to 3.6V	4.5			ns
		IOV _{DD} = AV _{DD} = 3.6V to 5.5V	4.5			ns
t ₇	24th SCLK Falling Edge to SYNC Rising Edge	IOV _{DD} = AV _{DD} = 2.7V to 3.6V	0			ns
		IOV _{DD} = AV _{DD} = 3.6V to 5.5V	0			ns
t ₈	Minimum SYNC HIGH Time	IOV _{DD} = AV _{DD} = 2.7V to 3.6V	50			ns
		IOV _{DD} = AV _{DD} = 3.6V to 5.5V	33			ns
t ₉	24th SCLK Falling Edge to SYNC Falling Edge	IOV _{DD} = AV _{DD} = 2.7V to 5.5V	130			ns

NOTES: (1) All input signals are specified with t_R = t_F = 3ns (10% to 90% of AV_{DD}) and timed from a voltage level of (V_{IL} + V_{IH})/2. (2) See Serial Write Operation timing diagram, below. (3) Maximum SCLK frequency is 30MHz at IOV_{DD} = AV_{DD} = +3.6V to +5.5V and 20MHz at IOV_{DD} = AV_{DD} = +2.7V to +3.6V.

SERIAL WRITE OPERATION

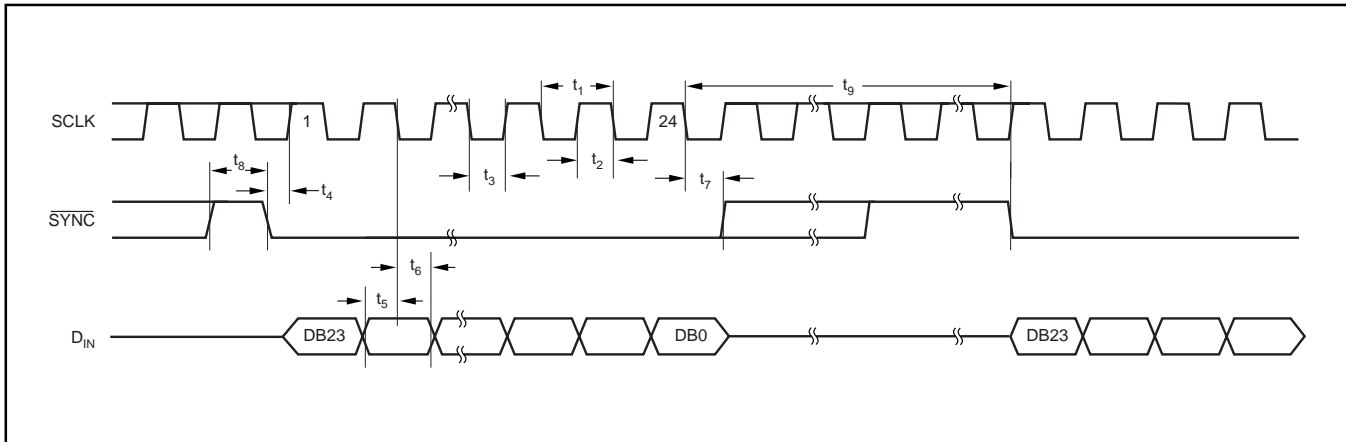

TYPICAL CHARACTERISTICS

At $T_A = +25^\circ\text{C}$, unless otherwise noted.

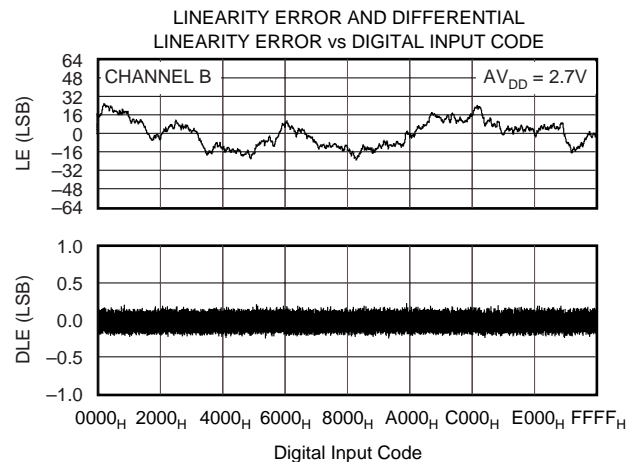
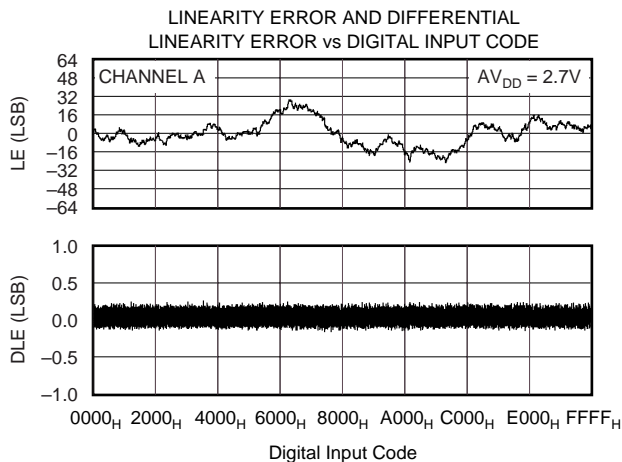
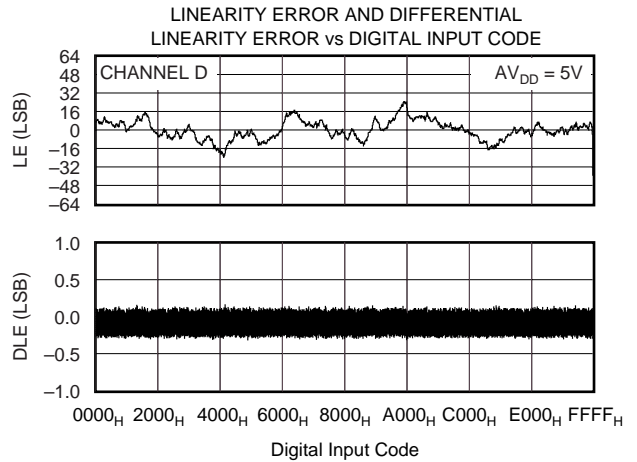
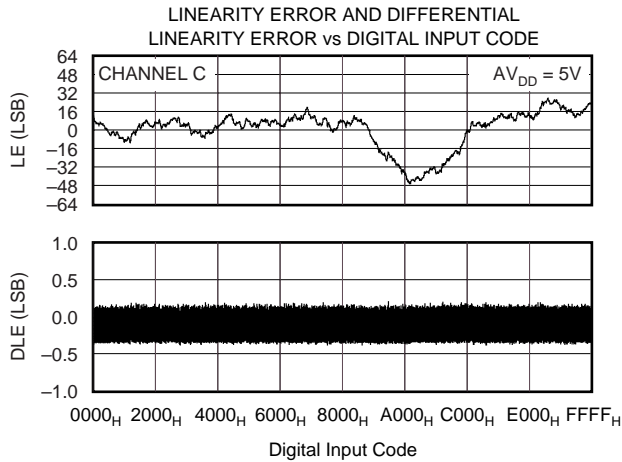
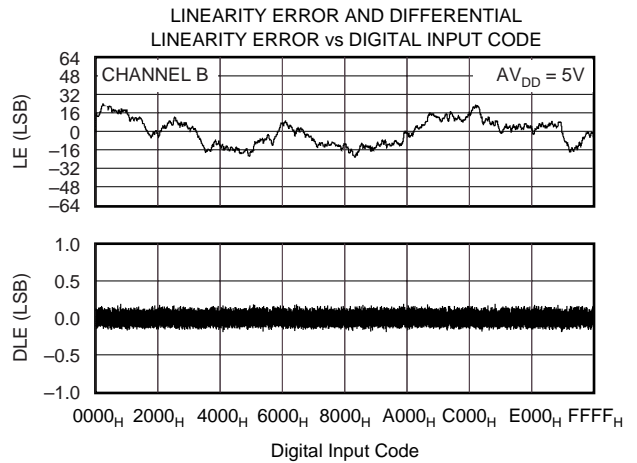
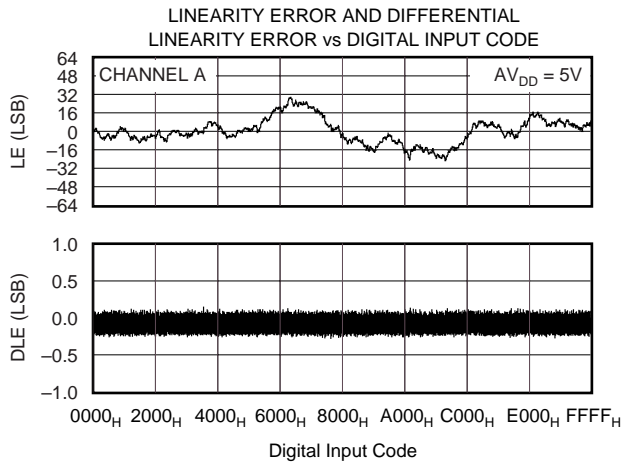

TYPICAL CHARACTERISTICS (Cont.)

At $T_A = +25^\circ\text{C}$, unless otherwise noted.

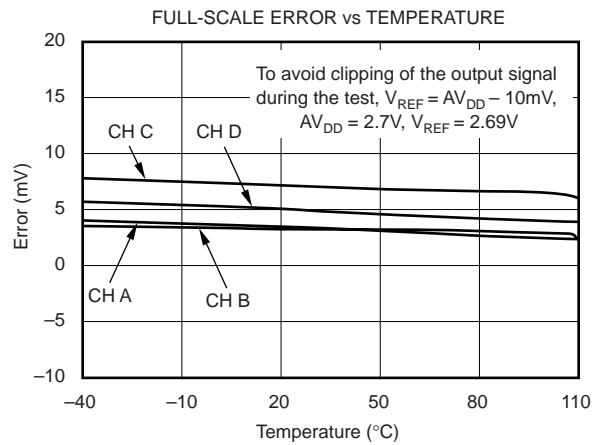
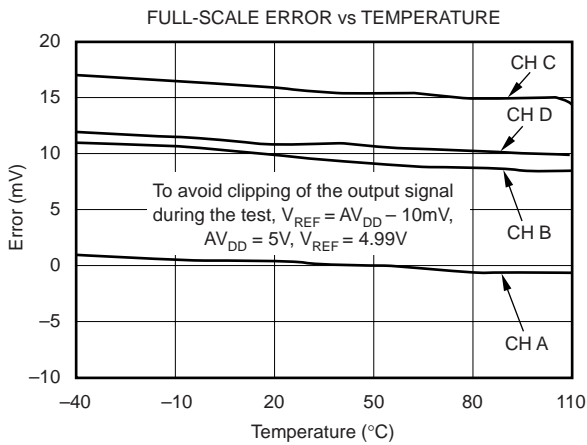
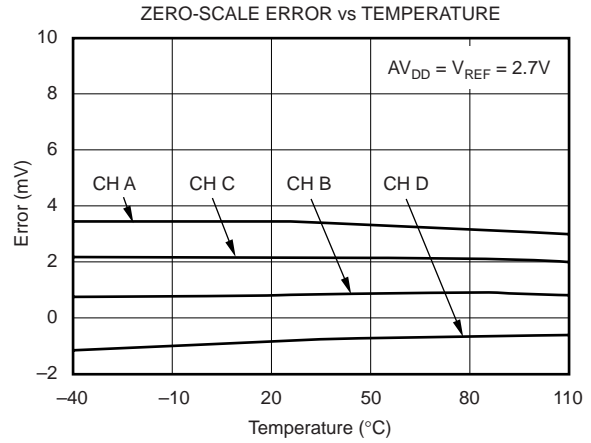
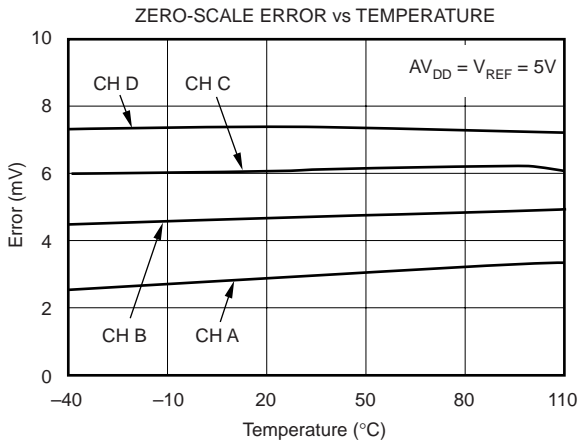
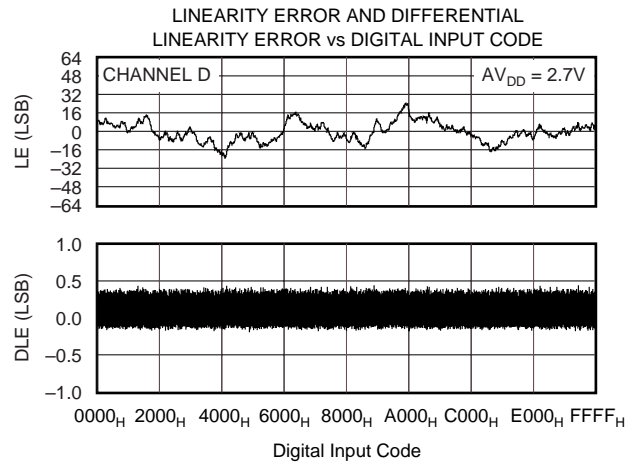
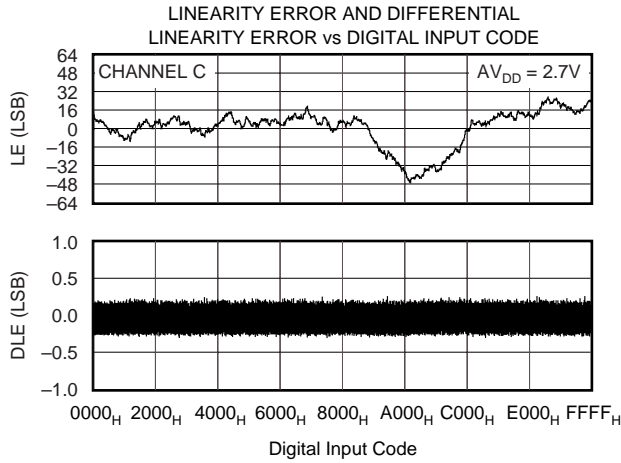

TYPICAL CHARACTERISTICS (Cont.)

At $T_A = +25^\circ\text{C}$, unless otherwise noted.

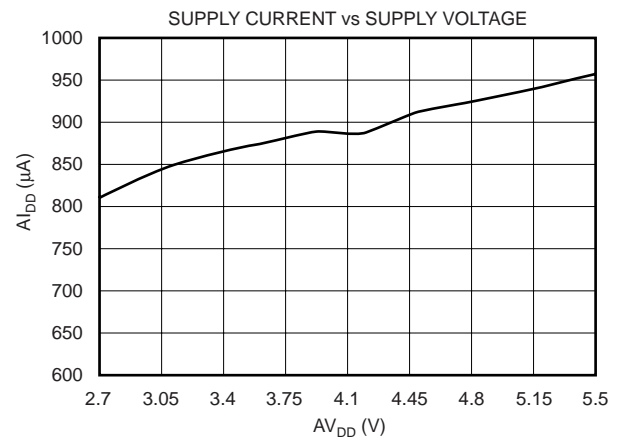
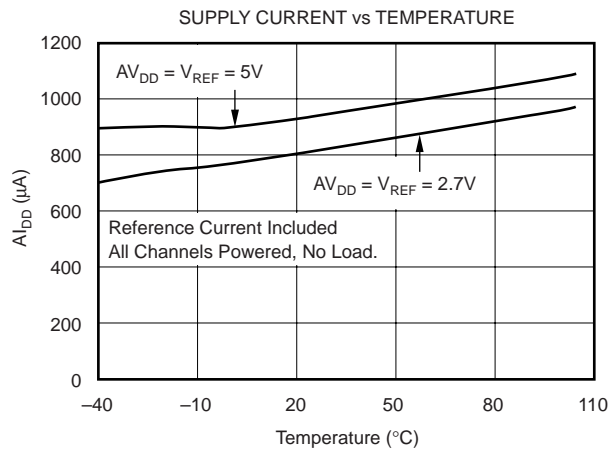
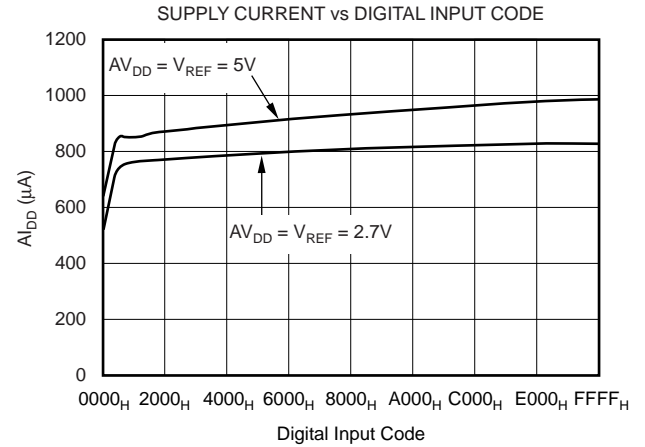
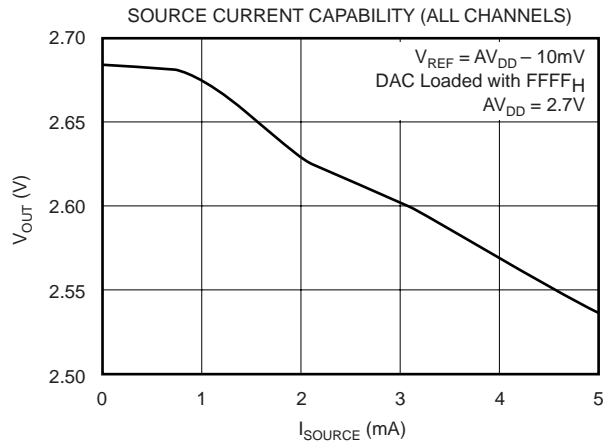
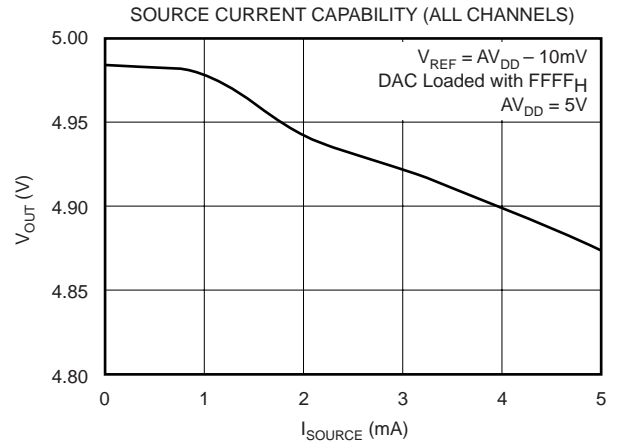
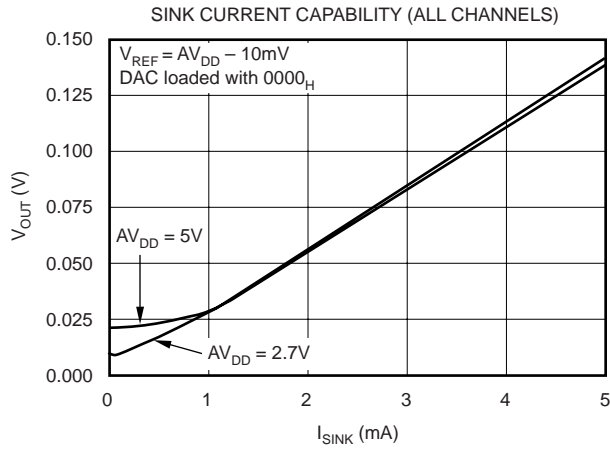

TYPICAL CHARACTERISTICS (Cont.)

At $T_A = +25^\circ\text{C}$, unless otherwise noted.

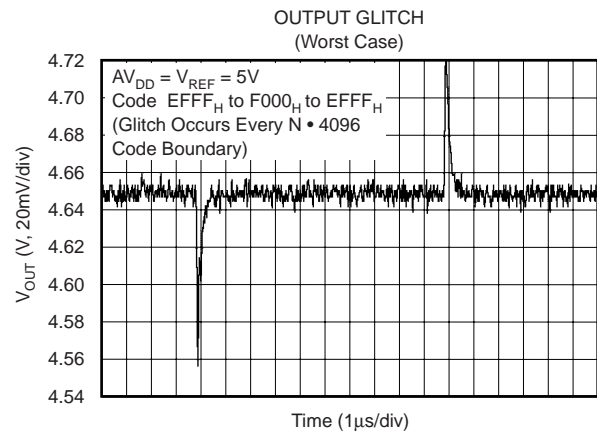
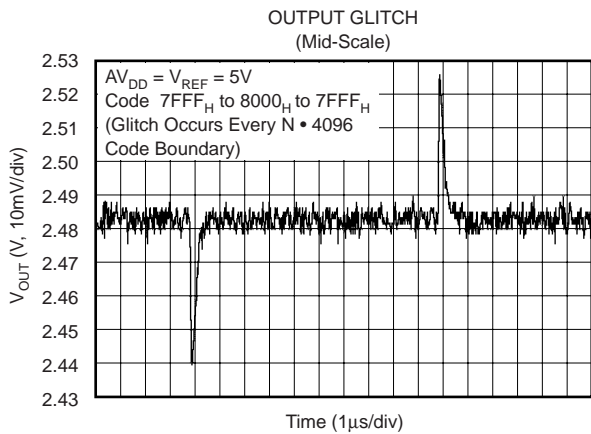
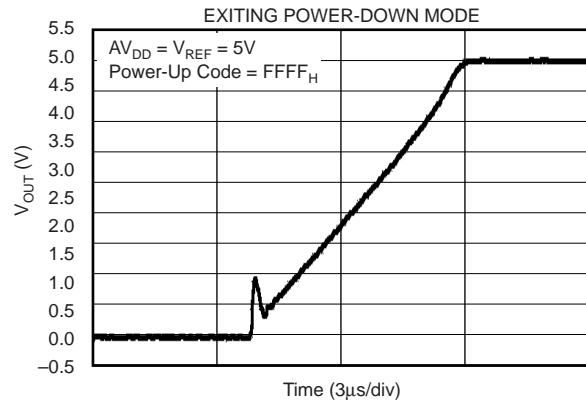
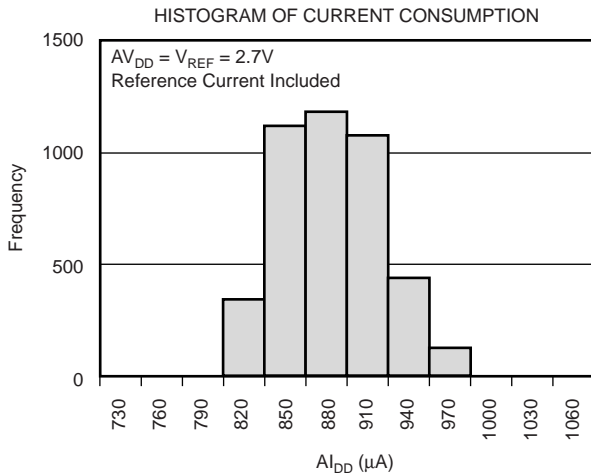
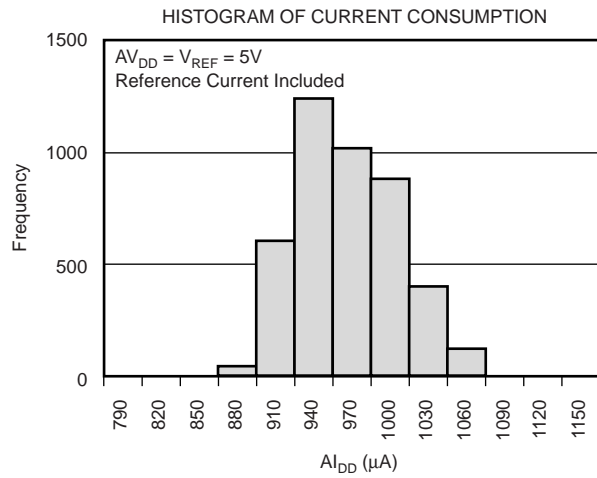
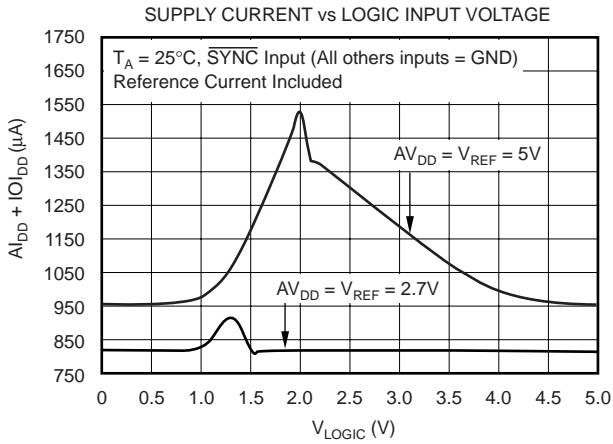

TYPICAL CHARACTERISTICS (Cont.)

At $T_A = +25^\circ\text{C}$, unless otherwise noted.

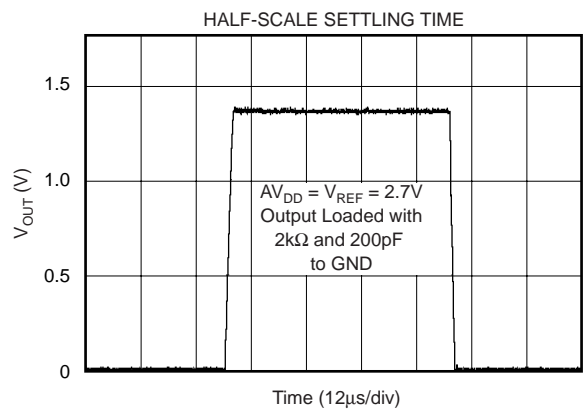
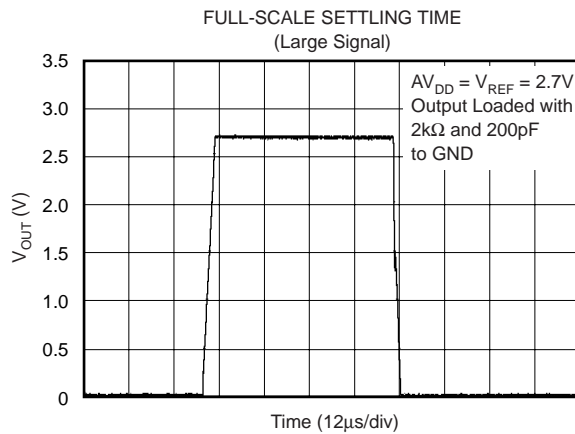
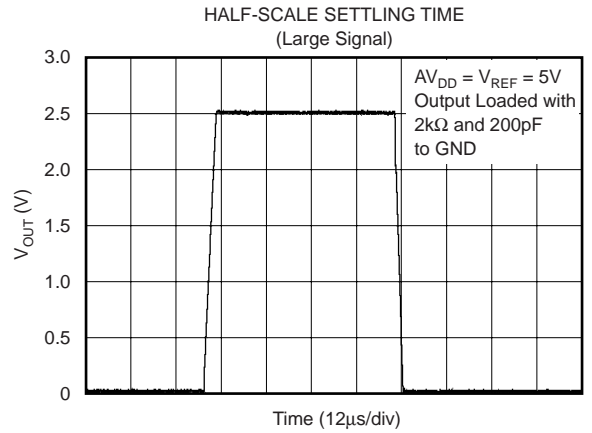
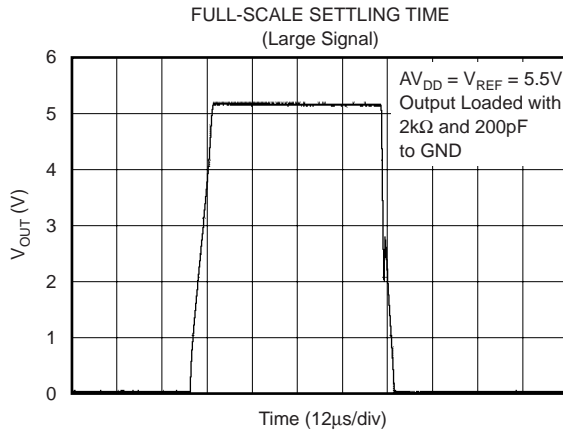
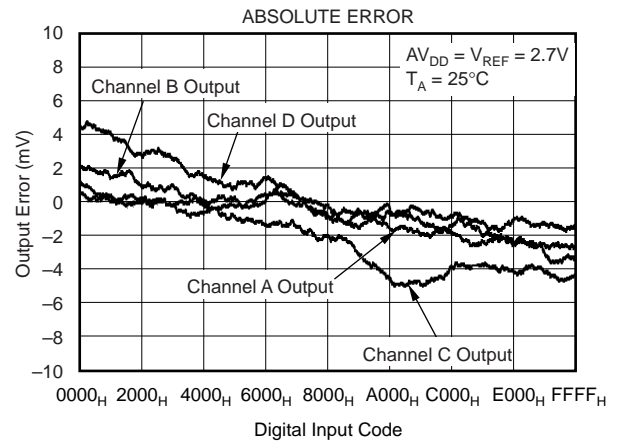
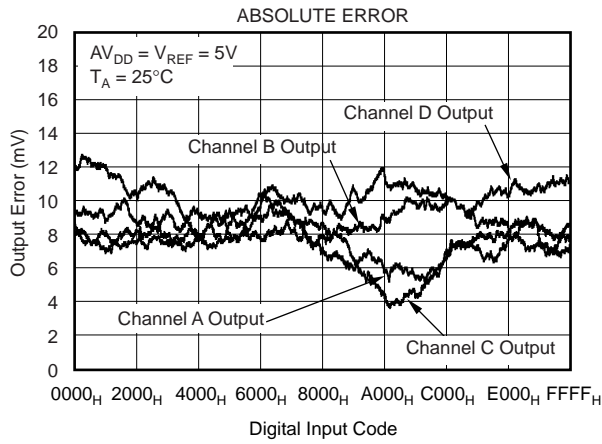

TYPICAL CHARACTERISTICS (Cont.)

At $T_A = +25^\circ\text{C}$, unless otherwise noted.

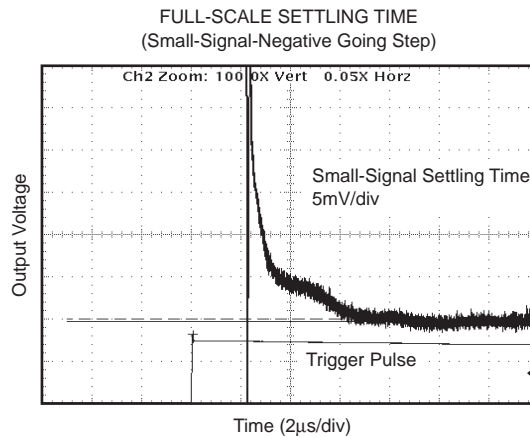
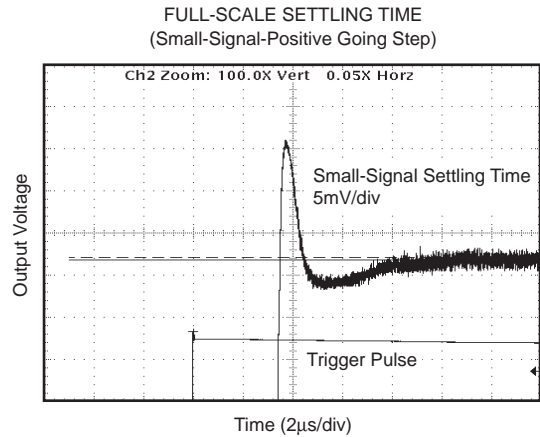
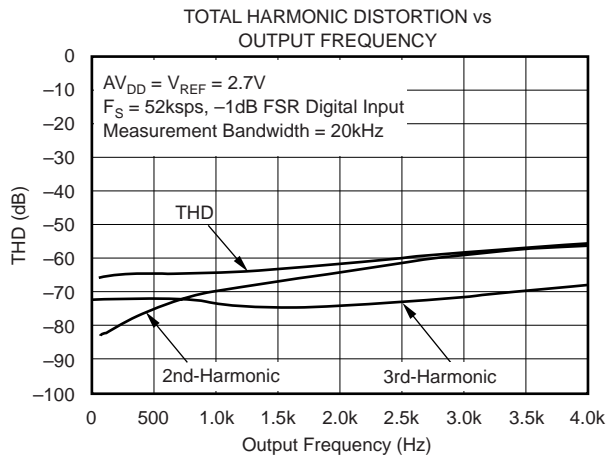
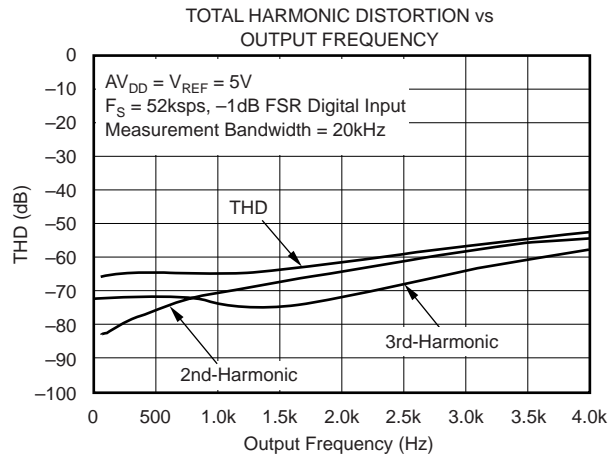
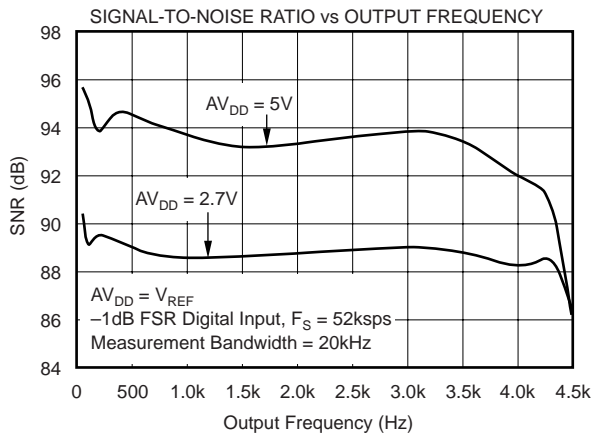

THEORY OF OPERATION

DAC SECTION

The architecture of each channel of the DAC8534 consists of a resistor-string DAC followed by an output buffer amplifier. Figure 1 shows a simplified block diagram of the DAC architecture.

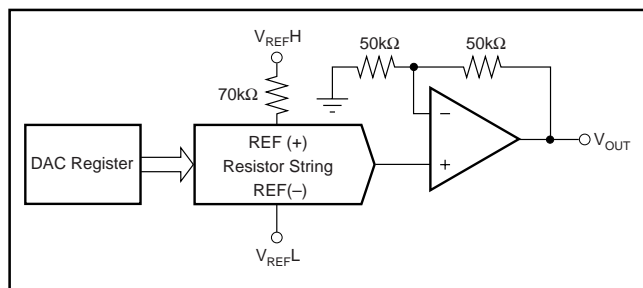

FIGURE 1. DAC8534 Architecture.

The input coding for each device is unipolar straight binary, so the ideal output voltage is given by:

$$V_{OUTX} = 2 \cdot V_{REFL} + (V_{REFH} - V_{REFL}) \cdot \frac{D_{IN}}{65536}$$

where D = decimal equivalent of the binary code that is loaded to the DAC register; it can range from 0 to 65535. V_{OUTX} refers to channel A or through D.

RESISTOR STRING

The resistor string section is shown in Figure 2. It is simply a divide-by-2 resistor followed by a string of resistors. The code loaded into the DAC register determines at which node on the string the voltage is tapped off. This voltage is then applied to the output amplifier by closing one of the switches connecting the string to the amplifier.

OUTPUT AMPLIFIER

Each output buffer amplifier is capable of generating rail-to-rail voltages on its output which approaches an output range of 0V to AV_{DD} (gain and offset errors must be taken into account). Each buffer is capable of driving a load of 2kΩ in parallel with 1000pF to GND. The source and sink capabilities of the output amplifier can be seen in the typical characteristics.

SERIAL INTERFACE

The DAC8534 uses a 3-wire serial interface (\overline{SYNC} , SCLK, and D_{IN}), which is compatible with SPI™, QSPI™, and Microwire™ interface standards, as well as most DSPs. See the Serial Write Operation timing diagram for an example of a typical write sequence.

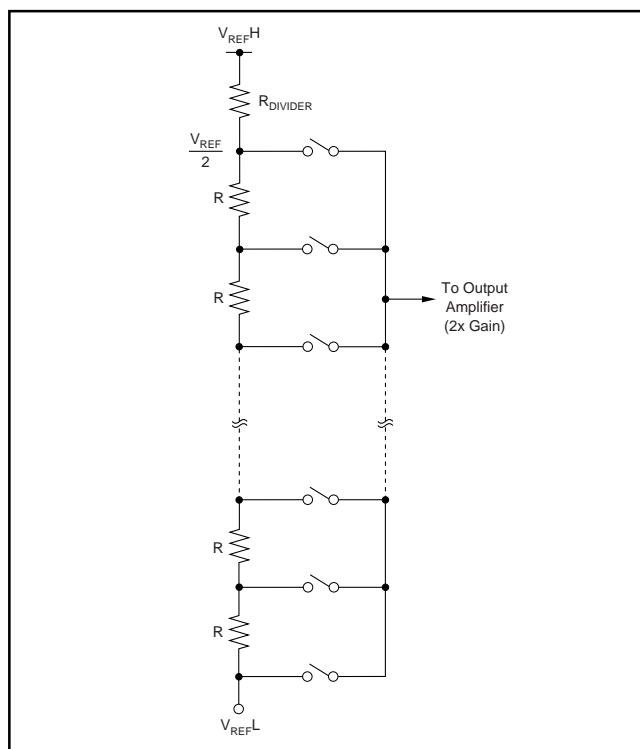

FIGURE 2. Resistor String.

The write sequence begins by bringing the \overline{SYNC} line LOW. Data from the D_{IN} line is clocked into the 24-bit shift register on each falling edge of SCLK. The serial clock frequency can be as high as 30MHz, making the DAC8534 compatible with high-speed DSPs. On the 24th falling edge of the serial clock, the last data bit is clocked into the shift register and the shift register gets locked. Further clocking does not change the shift register data. Once 24 bits are locked into the shift register, the 8MSBs are used as control bits and the 16LSBs are used as data. After receiving the 24th falling clock edge, DAC8534 decodes the 8 control bits and 16 data bits to perform the required function, without waiting for a \overline{SYNC} rising edge. A new SPI sequence starts at the next falling edge of \overline{SYNC} . A rising edge of \overline{SYNC} before the 24-bit sequence is complete resets the SPI interface; no data transfer occurs.

At this point, the \overline{SYNC} line may be kept LOW or brought HIGH. In either case, the minimum delay time from the 24th falling SCLK edge to the next falling \overline{SYNC} edge must be met in order to properly begin the next cycle. To assure the lowest power consumption of the device, care should be taken that the digital input levels are as close to each rail as possible. (Please refer to the "Typical Characteristics" section for the "Supply Current vs Logic Input Voltage" transfer characteristic curve.)

IOV_{DD} AND VOLTAGE TRANSLATORS

The IOV_{DD} pin powers the digital input structures of the DAC8534. For single-supply operation, it could be tied to AV_{DD} . For dual-supply operation, the IOV_{DD} pin provides interface flexibility with various CMOS logic families and it should be connected to the logic supply of the system. Analog circuits and internal logic of the DAC8534 use AV_{DD} as the supply voltage. The external logic high inputs get translated to AV_{DD} by level shifters. These level shifters use the IOV_{DD} voltage as a

reference to shift the incoming logic HIGH levels to AV_{DD} . IOV_{DD} is ensured to operate from 2.7V to 5.5V regardless of the AV_{DD} voltage, which ensures compatibility with various logic families. Although specified down to 2.7V, IOV_{DD} will operate at as low as 1.8V with degraded timing and temperature performance. For lowest power consumption, logic V_{IH} levels should be as close as possible to IOV_{DD} , and logic V_{IL} levels should be as close as possible to GND voltages.

INPUT SHIFT REGISTER

The input shift register (SR) of the DAC8534 is 24 bits wide, as shown in Figure 3, and is made up of 8 control bits (DB16-DB23) and 16 data bits (DB0-DB15). The first two control bits (DB22 and DB23) are the address match bits. The DAC8534 offers additional hardware-enabled addressing capability allowing a single host to talk to up to four DAC8534s through a single SPI bus without any glue logic, enabling up to 16-channel operation. The state of DB23 should match the state of pin A1; similarly, the state of DB22 should match the state of pin A0. If there is no match, the control command and the data (DB21...DB0) are ignored by the DAC8534. That is, if there is no match, the DAC8534 is not addressed. Address matching can be overridden by the broadcast update, as will be explained.

LD 1 (DB20) and LD 0 (DB21) control the updating of each analog output with the specified 16-bit data value or power-down command. Bit DB19 is a "Don't Care" bit which does not affect the operation of the DAC8534 and can be 1 or 0. The DAC Channel Select Bits (DB17, DB18) control the destination of the data (or power-down command) from DAC A through DAC D. The final control bit, PD0 (DB16), selects the power-down mode of the DAC8534 channels.

The DAC8534 also supports a number of different load commands. The load commands include broadcast commands to address all the DAC8534s on an SPI bus. The load commands can be summarized as follows:

DB21 = 0 and DB20 = 0: Single-channel store. The temporary register (data buffer) corresponding to a DAC selected by DB18 and DB17 is updated with the contents of SR data (or power-down).

DB21 = 0 and DB20 = 1: Single-channel update. The temporary register and DAC register corresponding to a DAC selected by DB18 and DB17 are updated with the contents of SR data (or power-down).

DB21 = 1 and DB20 = 0: Simultaneous update. A channel selected by DB18 and DB17 gets updated with the SR data, and simultaneously, all the other channels get updated with previous stored data (or power-down).

DB21 = 1 and DB20 = 1: Broadcast update. All the DAC8534s on the SPI bus respond, regardless of address matching. If DB18 = 0, then SR data gets ignored, all channels from all

DAC8534s get updated with previously stored data (or power-down). If DB18 = 1, then SR data (or power-down) updates all channels of all DAC8534s in the system. This broadcast update feature allows the simultaneous update of up to 16 channels.

Power-down/data selection is as follows:

DB16 is a power-down flag. If this flag is set, then DB15 and DB14 select one of the four power-down modes of the device as described in Table I. If DB16 = 1, DB15 and DB14 no longer represent the two MSBs of data, they represent a power-down condition described in Table I. Similar to data, power-down conditions can be stored at the temporary registers of each DAC. It is possible to update DACs simultaneously either with data, power-down, or a combination of both.

Please refer to Table II for more information.

PD0 (DB16)	PD1 (DB15)	PD2 (DB14)	OPERATING MODE
1	0	0	Output High Impedance
1	0	1	Output Typically 1kΩ to GND
1	1	0	Output Typically 100kΩ to GND
1	1	1	Output High Impedance

TABLE I. DAC8534 Power-Down Modes.

SYNC INTERRUPT

In a normal write sequence, the $\overline{\text{SYNC}}$ line is kept LOW for at least 24 falling edges of SCLK and the addressed DAC register is updated on the 24th falling edge. However, if $\overline{\text{SYNC}}$ is brought HIGH before the 24th falling edge, it acts as an interrupt to the write sequence; the shift register is reset and the write sequence is discarded. Neither an update of the data buffer contents, DAC register contents, nor a change in the operating mode occurs (see Figure 4).

POWER-ON RESET

The DAC8534 contains a power-on reset circuit that controls the output voltage during power-up. On power-up, the DAC registers are filled with zeros and the output voltages are set to zero-scale; they remain there until a valid write sequence and load command is made to the respective DAC channel. This is useful in applications where it is important to know the state of the output of each DAC output while the device is in the process of powering up. No device pin should be brought high before power is applied to the device.

POWER-DOWN MODES

The DAC8534 utilizes four modes of operation. These modes are accessed by setting three bits (PD2, PD1, and PD0) in the shift register and performing a "Load" action to the DACs. The DAC8534 offers a very flexible power-down interface based on channel register operation. A channel consists of a

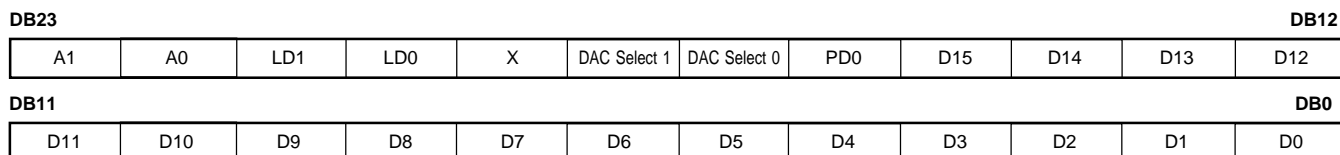

FIGURE 3. DAC8534 Data Input Register Format.

D23	D22	D21	D20	D19	D18	D17	D16	D15	D14	D13-D0	DESCRIPTION
A1	A0	Load 1	Load 0	Don't Care	DAC Sel 1	DAC Sel 0	PD0	MSB	MSB-1	MSB-2...LSB	
(Address Select)											
0/1	0/1	See Below									This address selects 1 of 4 possible devices on a single SPI data bus based on each device's address pin(s) state.
(A0 and A1 should correspond to the package address set via pins 13 and 14.)		0	0	X	0	0	0	Data		Write To Buffer A w/Data	
		0	0	X	0	1	0	Data		Write To Buffer B w/Data	
		0	0	X	1	0	0	Data		Write To Buffer C w/Data	
		0	0	X	1	1	0	Data		Write To Buffer D w/Data	
		0	0	X	(00, 01, 10, or 11)		1	(see Table I)	0	Write To Buffer (selected by DB17 and DB18) w/Power-Down Command	
		0	1	X	(00, 01, 10, or 11)		0	Data		Write To Buffer w/Data and Load DAC (selected by DB17 and DB18)	
		0	1	X	(00, 01, 10, or 11)		1	(see Table I)	0	Write To Buffer w/Power-Down Command and Load DAC (selected by DB17 and DB18)	
		1	0	X	(00, 01, 10, or 11)		0	Data		Write To Buffer w/Data (selected by DB17 and DB18) and Load All DACs	
		1	0	X	(00, 01, 10, or 11)		1	(see Table I)	0	Write To Buffer w/Power-Down Command (selected by DB17 and DB18) and Load All DACs	
Broadcast Modes											
X	X	1	1	X	0	X	X	X		Load All DACs, All Device, and All Buffers with Stored Data	
X	X	1	1	X	1	X	0	Data		Write To All Devices and Load All Dacs, with SR Data	
X	X	1	1	X	1	X	1	(see Table I)	0	Write To All Devices w/Power-Down Command in SR	

TABLE II. Control Matrix.

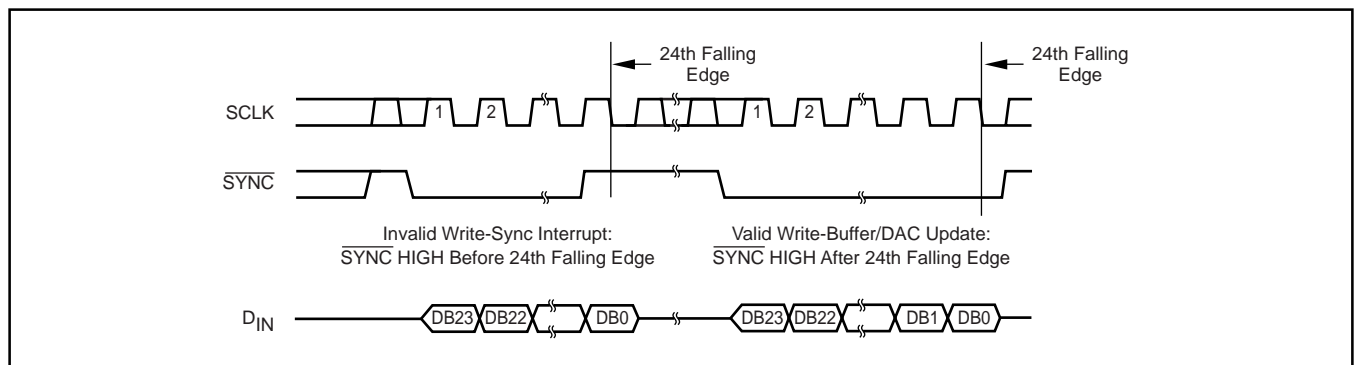

FIGURE 4. Interrupt and Valid $\overline{\text{SYNC}}$ Timing.

single 16-bit DAC with power-down circuitry, a temporary storage register (TR), and a DAC register (DR). TR and DR are both 18-bit wide. Two MSBs represent power-down condition and 16LSBs represent data for TR and DR. By adding bits 17 and 18 to TR and DR, a power-down condition can be temporarily stored and used just like data. Internal circuits ensure that DB15 and DB14 get transferred to TR17 and TR16 (DR17 and DR16), when DB16 = 1.

The DAC8534 treats the power-down condition like data and all the operational modes are still valid for power-down. It is possible to broadcast a power-down condition to all the DAC8534s in a system, or it is possible to simultaneously power-down a channel while updating data on other channels.

DB16, DB15, and DB14 = 100 represent a power-down condition with Hi-Z output impedance for a selected channel. Same is true for 111. 101 represents a power-down condition with 1k output impedance and 110 represents a power-down condition with 100k output impedance.

When both bits are set to 0 or 1, the device enters a high-impedance state with a typical power consumption of 3pA at 5V. For the two low impedance output modes, however, the supply current falls to 100nA at 5V (50nA at 3V). Not only does the supply current fall, but the output stage is also internally switched from the output of the amplifier to a resistor network of known values. This has the advantage that the output impedance of the device is known while it is in power-down mode. There are three different options for power-down: the output is connected internally to GND through a 1kΩ resistor, a 100kΩ resistor, or it is left open-circuited (High-Impedance). The output stage is illustrated in Figure 5.

All analog circuitry is shut down when the power-down mode is activated. Each DAC will exit power-down when PD0 is set to 0, new data is written to the Data Buffer, and the DAC channel receives a "Load" command. The time to exit power-down is typically 2.5μs for $V_{DD} = 5V$ and 5μs for $V_{DD} = 3V$ (see the Typical Characteristics).

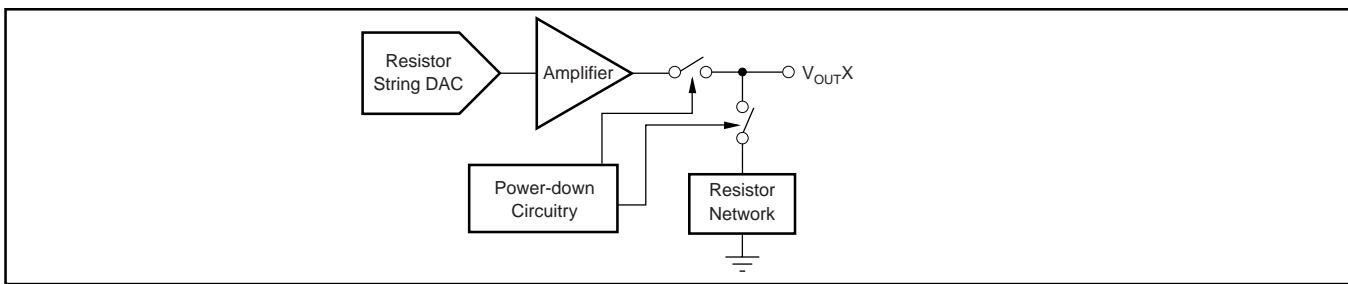

FIGURE 5. Output Stage During Power-Down (High-Impedance).

OPERATION EXAMPLES

Example 1: Write to Data Buffer A; Through Buffer D; Load DAC A Through DAC D Simultaneously

- 1st—Write to Data Buffer A:

A1	A0	LD1	LD0	DC	DAC Sel 1	DAC Sel 0	PD0	DB15	DB1	DB0
0	0	0	0	X	0	0	0	D15	D1	D0

- 2nd—Write to Data Buffer B:

A1	A0	LD1	LD0	DC	DAC Sel 1	DAC Sel 0	PD0	DB15	DB1	DB0
0	0	0	0	X	0	1	0	D15	D1	D0

- 3rd—Write to Data Buffer C:

A1	A0	LD1	LD0	DC	DAC Sel 1	DAC Sel 0	PD0	DB15	DB1	DB0
0	0	0	0	X	1	0	0	D15	D1	D0

- 4th—Write to Data Buffer D and simultaneously update all DACs:

A1	A0	LD1	LD0	DC	DAC Sel 1	DAC Sel 0	PD0	DB15	DB1	DB0
0	0	1	0	X	1	1	0	D15	D1	D0

The DAC A, DAC B, DAC C, and DAC D analog outputs simultaneously settle to the specified values upon completion of the 4th write sequence. (The “Load” command moves the digital data from the data buffer to the DAC register at which time the conversion takes place and the analog output is updated. “Completion” occurs on the 24th falling SCLK edge after $\overline{\text{SYNC}} \text{ LOW}$.)

Example 2: Load New Data to DAC A Through DAC D Sequentially

- 1st—Write to Data Buffer A and Load DAC A: DAC A output settles to specified value upon completion:

A1	A0	LD1	LD0	DC	DAC Sel 1	DAC Sel 0	PD0	DB15	DB1	DB0
0	0	0	1	X	0	0	0	D15	D1	D0

- 2nd—Write to Data Buffer B and Load DAC B: DAC B output settles to specified value upon completion:

A1	A0	LD1	LD0	DC	DAC Sel 1	DAC Sel 0	PD0	DB15	DB1	DB0
0	0	0	1	X	0	1	0	D15	D1	D0

- 3rd—Write to Data Buffer C and Load DAC C: DAC C output settles to specified value upon completion:

A1	A0	LD1	LD0	DC	DAC Sel 1	DAC Sel 0	PD0	DB15	DB1	DB0
0	0	0	1	X	1	0	0	D15	D1	D0

- 4th—Write to Data Buffer D and Load DAC D: DAC D output settles to specified value upon completion:

A1	A0	LD1	LD0	DC	DAC Sel 1	DAC Sel 0	PD0	DB15	DB1	DB0
0	0	0	1	X	1	1	0	D15	D1	D0

After completion of each write cycle, DAC analog output settles to the voltage specified.

Example 3: Power-Down DAC A and DAC B to 1k Ω and Power-Down DAC C and DAC D to 100k Ω Simultaneously

- Write power-down command to Data Buffer A: DAC A to 1k Ω .

A1	A0	LD1	LD0	DC	DAC Sel 1	DAC Sel 0	PD0	DB15	DB14	DB13
0	0	0	0	X	0	0	1	0	1	X

- Write power-down command to Data Buffer B: DAC B to 1kΩ.

A1	A0	LD1	LD0	DC	DAC Sel 1	DAC Sel 0	PD0	DB15	DB14	DB13
0	0	0	0	X	0	1	1	0	1	X

- Write power-down command to Data Buffer C: DAC C to 100kΩ.

A1	A0	LD1	LD0	DC	DAC Sel 1	DAC Sel 0	PD0	DB15	DB14	DB13
0	0	0	0	X	1	0	1	1	0	X

- Write power-down command to Data Buffer D: DAC D to 100kΩ and Simultaneously Update all DACs.

A1	A0	LD1	LD0	DC	DAC Sel 1	DAC Sel 0	PD0	DB15	DB14	DB13
0	0	1	0	X	1	1	1	1	0	X

The DAC A, DAC B, DAC C, and DAC D analog outputs simultaneously power-down to each respective specified mode upon completion of the 4th write sequence.

Example 4: Power-Down DAC A Through DAC D to High-Impedance Sequentially:

- Write power-down command to Data Buffer A and Load DAC A: DAC A output = High-Z:

A1	A0	LD1	LD0	DC	DAC Sel 1	DAC Sel 0	PD0	DB15	DB14	DB13
0	0	0	1	X	0	0	1	1	1	X

- Write power-down command to Data Buffer B and Load DAC B: DAC B output = High-Z:

A1	A0	LD1	LD0	DC	DAC Sel 1	DAC Sel 0	PD0	DB15	DB14	DB13
0	0	0	1	X	0	1	1	1	1	X

- Write power-down command to Data Buffer C and Load DAC C: DAC C output = High-Z:

A1	A0	LD1	LD0	DC	DAC Sel 1	DAC Sel 0	PD0	DB15	DB14	DB13
0	0	0	1	X	1	0	1	1	1	X

- Write power-down command to Data Buffer D and Load DAC D: DAC D output = High-Z:

A1	A0	LD1	LD0	DC	DAC Sel 1	DAC Sel 0	PD0	DB15	DB14	DB13
0	0	0	1	X	1	1	1	1	1	X

The DAC A, DAC B, DAC C, and DAC D analog outputs sequentially power-down to high-impedance upon completion of the 1st, 2nd, 3rd, and 4th write sequences, respectively.

LDAC FUNCTIONALITY

The DAC8534 offers both a software and hardware simultaneous update function. The DAC8534 double-buffered architecture has been designed so that new data can be entered for each DAC without disturbing the analog outputs. The software simultaneous update capability is controlled by the Load 1 (LD1) and Load 0 (LD0) control bits. By setting Load 1 equal to "1" all of the DAC registers will be updated on the falling edge of the 24th clock signal. When the new data has been entered into the device, all of the DAC outputs can be updated simultaneously and synchronously with the clock.

The internal DAC register is edge triggered and not level triggered, therefore, when the LDAC pin signal is transitioned from LOW to HIGH, the digital word currently in the DAC input register is latched. Additionally, it allows the DAC input registers to be written to at any point; then, the DAC output voltages can be asynchronously changed via the LDAC pin. The LDAC trigger should only be used after the buffers are properly updated through software. If DAC outputs are desired to be updated through software only, the LDAC pin must be tied low permanently.

MICROPROCESSOR INTERFACING

DAC8534 to 8051 INTERFACE

See Figure 6 for a serial interface between the DAC8534 and a typical 8051-type microcontroller. The setup for the interface is as follows: TXD of the 8051 drives SCLK of the DAC8534, while RXD drives the serial data line of the device. The $\overline{\text{SYNC}}$ signal is derived from a bit-programmable pin on the port of the 8051. In this case, port line P3.3 is used. When data is to be transmitted to the DAC8534, P3.3 is taken LOW. The 8051 transmits data in 8-bit bytes; thus only eight falling clock edges occur in the transmit cycle. To load data to the DAC, P3.3 is left LOW after the first eight bits are transmitted, then a second and third write cycle is initiated to transmit the remaining data. P3.3 is taken HIGH following the completion of the third write cycle. The 8051 outputs the serial data in a format which presents the LSB first, while the DAC8534 requires its data with the MSB as the first bit received. The 8051 transmit routine must therefore take this into account, and "mirror" the data as needed.

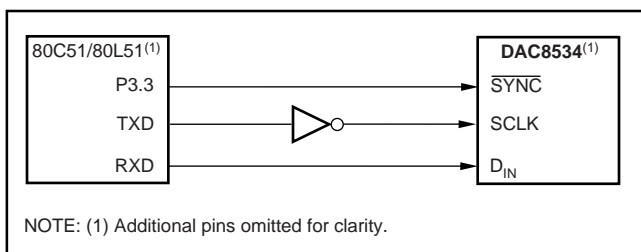

FIGURE 6. DAC8534 to 80C51/80L51 Interface.

DAC8534 to Microwire INTERFACE

Figure 7 shows an interface between the DAC8534 and any Microwire compatible device. Serial data is shifted out on the falling edge of the serial clock and is clocked into the DAC8534 on the rising edge of the CK signal.

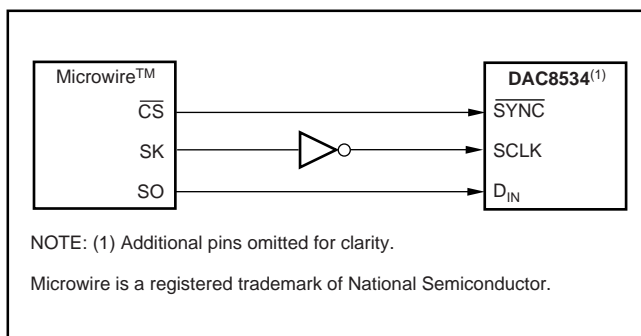

FIGURE 7. DAC8534 to Microwire Interface.

DAC8534 to 68HC11 INTERFACE

Figure 8 shows a serial interface between the DAC8534 and the 68HC11 microcontroller. SCK of the 68HC11 drives the SCLK of the DAC8534, while the MOSI output drives the serial data line of the DAC. The SYNC signal is derived from a port line (PC7), similar to the 8051 diagram.

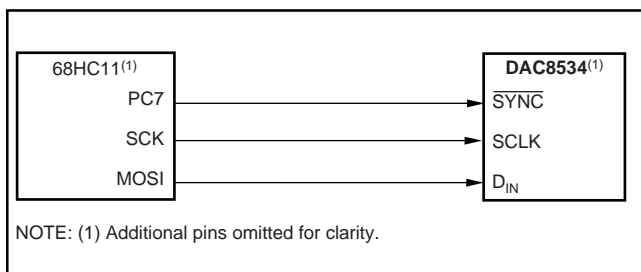

FIGURE 8. DAC8534 to 68HC11 Interface.

The 68HC11 should be configured so that its CPOL bit is 0 and its CPHA bit is 1. This configuration causes data appearing on the MOSI output to be valid on the falling edge of SCLK. When data is being transmitted to the DAC, the SYNC line is held LOW (PC7). Serial data from the 68HC11 is transmitted in 8-bit bytes with only eight falling clock edges occurring in the transmit cycle. (Data is transmitted MSB first.) In order to load data to the DAC8534, PC7 is left LOW after the first eight bits are transferred, then a second and third serial write operation is performed to the DAC. PC7 is taken HIGH at the end of this procedure.

DAC8534 to TMS320 DSP INTERFACE

Figure 9 shows the connections between the DAC8534 and a TMS320 Digital Signal Processor (DSP). A Single DSP can control up to four DAC8534s without any interface logic.

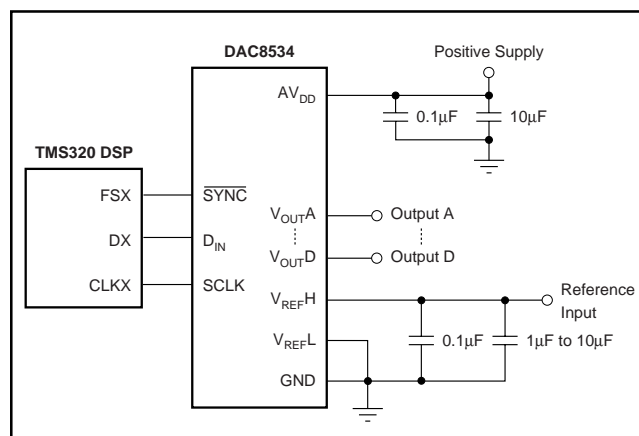

FIGURE 9. DAC8534 to TMS320 DSP.

APPLICATIONS

CURRENT CONSUMPTION

The DAC8534 typically consumes 250µA at $AV_{DD} = 5V$ and 225µA at $AV_{DD} = 3V$ for each active channel, including reference current consumption. Additional current consumption can occur at the digital inputs if $V_{IH} \ll IOV_{DD}$. For most efficient power operation, CMOS logic levels are recommended at the digital inputs to the DAC.

In power-down mode, typical current consumption is 200nA per channel. A delay time of 10ms to 20ms after a power-down command is issued to the DAC is typically sufficient for the power-down current to drop below 10µA.

DRIVING RESISTIVE AND CAPACITIVE LOADS

The DAC8534 output stage is capable of driving loads of up to 1000pF while remaining stable. Within the offset and gain error margins, the DAC8534 can operate rail-to-rail when driving a capacitive load. Resistive loads of 2kΩ can be driven by the DAC8534 while achieving a typical load regulation of 1%. As the load resistance drops below 2kΩ, the load regulation error increases. When the outputs of the DAC are driven to the positive rail under resistive loading, the PMOS transistor of each Class-AB output stage can enter into the linear region. When this occurs, the added IR voltage drop deteriorates the linearity performance of the DAC. This only occurs within approximately the top 20mV of the DAC's output voltage characteristic. The reference voltage applied to the DAC8534 may be reduced below the supply voltage applied to AV_{DD} in order to eliminate this condition if good linearity is a requirement at full-scale (under resistive loading conditions).

CROSSTALK AND AC PERFORMANCE

The DAC8534 architecture uses separate resistor strings for each DAC channel in order to achieve ultra-low crosstalk performance. DC crosstalk seen at one channel during a full-

scale change on the neighboring channel is typically less than 0.5LSBs. The AC crosstalk measured (for a full-scale, 1kHz sine wave output generated at one channel, and measured at the remaining output channel) is typically under -100dB . In addition, the DAC8534 can achieve typical AC performance of 96dB SNR (Signal-to-Noise Ratio) and 65dB THD (Total Harmonic Distortion), making the DAC8534 a solid choice for applications requiring high SNR at output frequencies at or below 4kHz.

OUTPUT VOLTAGE STABILITY

The DAC8534 exhibits excellent temperature stability of 5ppm/ $^{\circ}\text{C}$ typical output voltage drift over the specified temperature range of the device. This enables the output voltage of each channel to stay within a $\pm 25\mu\text{V}$ window for a $\pm 1^{\circ}\text{C}$ ambient temperature change.

Good Power-Supply Rejection Ratio (PSRR) performance reduces supply noise present on AV_{DD} from appearing at the outputs to well below $10\mu\text{V}$ -s. Combined with good DC noise performance and true 16-bit differential linearity, the DAC8534 becomes a perfect choice for closed-loop control applications.

SETTLING TIME AND OUTPUT GLITCH PERFORMANCE

Settling time to within the 16-bit accurate range of the DAC8534 is achievable within $10\mu\text{s}$ for a full-scale code change at the input. Worst-case settling times between consecutive code changes is typically less than $2\mu\text{s}$, enabling update rates up to 500ksps for digital input signals changing code-to-code. The high-speed serial interface of the DAC8534 is designed in order to support these high update rates.

For full-scale output swings, the output stage of each DAC8534 channel typically exhibits less than 100mV of overshoot and undershoot when driving a 200pF capacitive load. Code-to-code change glitches are extremely low given that the code-to-code transition does not cross an $\text{N} \times 4096$ code boundary. Due to internal segmentation of the DAC8534, code-to-code glitches occur at each crossing of an $\text{N} \times 4096$ code boundary. These glitches can approach 100nVs for $\text{N} = 15$, but settle out within $\sim 2\mu\text{s}$.

USING THE REF02 AS A POWER SUPPLY FOR THE DAC8534

Due to the extremely low supply current required by the DAC8534, a possible configuration is to use a REF02 +5V precision voltage reference to supply the required voltage to the DAC8534's supply input as well as the reference input, as shown in Figure 10. This is especially useful if the power supply is quite noisy or if the system supply voltages are at some value other than 5V. The REF02 will output a steady supply voltage for the DAC8534. If the REF02 is used, the current it needs to supply to the DAC8534 is 1.085mA typical and 1.78mA max for $\text{AV}_{\text{DD}} = 5\text{V}$. When a DAC output is loaded, the REF02 also needs to supply the current to the load. The total typical current required (with a $5\text{k}\Omega$ load on a given DAC output) is:

$$1.085\text{mA} + (5\text{V}/5\text{k}\Omega) = 2.085\text{mA}$$

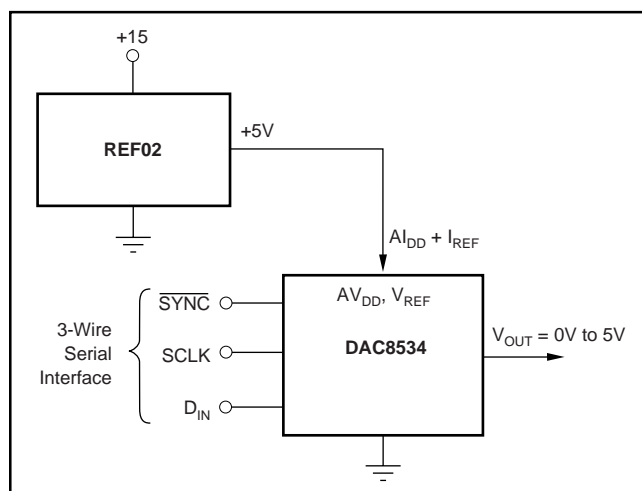

FIGURE 10. REF02 as a Power Supply to the DAC8534.

BIPOLAR OPERATION USING THE DAC8534

The DAC8534 has been designed for single-supply operation, but a bipolar output range is also possible using the circuit in Figure 11. The circuit shown will give an output voltage range of $\pm V_{\text{REF}}$. Rail-to-rail operation at the amplifier output is achievable using an amplifier such as the OPA703, as shown in Figure 11.

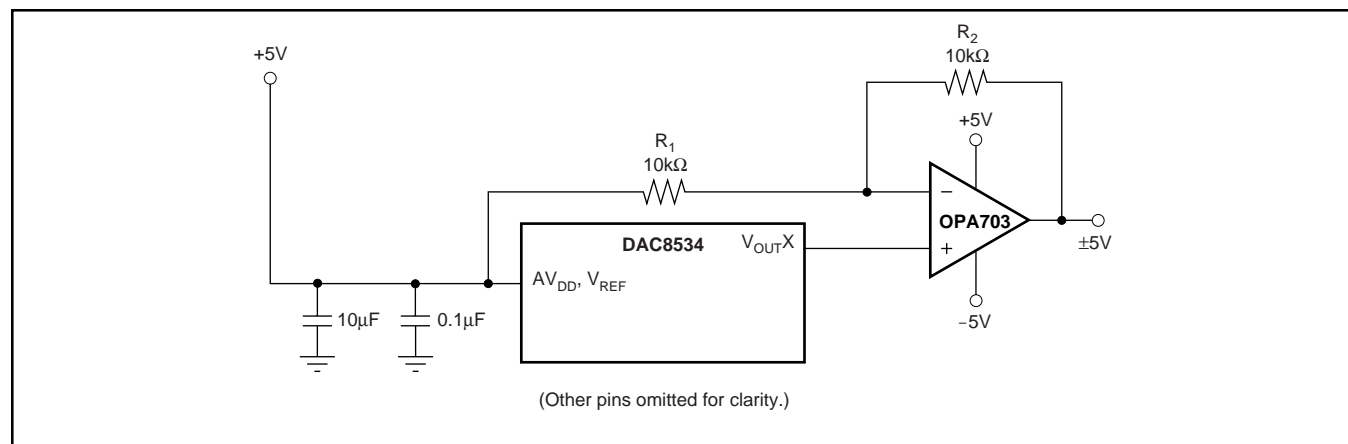

FIGURE 11. Bipolar Operation with the DAC8534.

The output voltage for any input code can be calculated as follows:

$$V_{\text{OUT}X} = \left[V_{\text{REF}} \cdot \left(\frac{D}{65536} \right) \cdot \left(\frac{R_1 + R_2}{R_1} \right) - V_{\text{REF}} \cdot \left(\frac{R_2}{R_1} \right) \right]$$

where D represents the input code in decimal (0–65535).

With $V_{\text{REF}} = 5\text{V}$, $R_1 = R_2 = 10\text{k}\Omega$:

$$V_{\text{OUT}X} = \left(\frac{10 \cdot D}{65536} \right) - 5\text{V}$$

This is an output voltage range of $\pm 5\text{V}$ with 0000_{H} corresponding to a -5V output and FFFF_{H} corresponding to a $+5\text{V}$ output. Similarly, using $V_{\text{REF}} = 2.5\text{V}$, a $\pm 2.5\text{V}$ output voltage range can be achieved.

LAYOUT

A precision analog component requires careful layout, adequate bypassing, and clean, well-regulated power supplies.

The DAC8534 offers single-supply operation, and it will often be used in close proximity with digital logic, microcontrollers, microprocessors, and digital signal processors. The more digital logic present in the design and the higher the switching speed, the more difficult it will be to keep digital noise from appearing at the output.

Due to the single ground pin of the DAC8534, all return currents, including digital and analog return currents for the DAC, must flow through a single point. Ideally, GND would be connected directly to an analog ground plane. This plane would be separate from the ground connection for the digital components until they were connected at the power-entry point of the system.

The power applied to AV_{DD} should be well regulated and low noise. Switching power supplies and DC/DC converters will often have high-frequency glitches or spikes riding on the output voltage. In addition, digital components can create similar high-frequency spikes as their internal logic switches states. This noise can easily couple into the DAC output voltage through various paths between the power connections and analog output.

As with the GND connection, AV_{DD} should be connected to a positive power-supply plane or trace that is separate from the connection for digital logic until they are connected at the power-entry point. In addition, a $1\mu\text{F}$ to $10\mu\text{F}$ capacitor in parallel with a $0.1\mu\text{F}$ bypass capacitor is strongly recommended. In some situations, additional bypassing may be required, such as a $100\mu\text{F}$ electrolytic capacitor or even a “Pi” filter made up of inductors and capacitors—all designed to essentially low-pass filter the supply, removing the high-frequency noise.

Up to four DAC8534 devices can be used on a single SPI bus without any glue logic to create a high channel count solution. Special attention is required to avoid digital signal integrity problems when using multiple DAC8534s on the same SPI bus. Signal integrity of $\overline{\text{SYNC}}$, SCLK, and D_{IN} lines will not be an issue as long as the rise times of these digital signals are longer than six times the propagation delay between any two DAC8534 devices. Propagation speed is approximately six inches/ns on standard PCBs. Therefore, if the digital signal risetime is 1ns, the distance between any two DAC8534 devices is recommended not to exceed 1 inch. If the DAC8534s have to be further apart on the PCB, the signal rise times should be reduced by placing series resistors at the drivers for $\overline{\text{SYNC}}$, SCLK, and D_{IN} lines. If the largest distance between any two DAC8534s has to be six inches, the risetime should be reduced to 6ns with an RC network formed by the series resistor at the digital driver and the total trace and input capacitance on the PCB.

PACKAGING INFORMATION

Orderable Device	Status (1)	Package Type	Package Drawing	Pins	Package Qty	Eco Plan (2)	Lead/Ball Finish	MSL Peak Temp (3)	Op Temp (°C)	Top-Side Markings (4)	Samples
DAC8534IPW	ACTIVE	TSSOP	PW	16	90	Green (RoHS & no Sb/Br)	CU NIPDAU	Level-1-260C-UNLIM	-40 to 105	D8534I	Samples
DAC8534IPWG4	ACTIVE	TSSOP	PW	16	90	Green (RoHS & no Sb/Br)	CU NIPDAU	Level-1-260C-UNLIM	-40 to 105	D8534I	Samples
DAC8534IPWR	ACTIVE	TSSOP	PW	16	2000	Green (RoHS & no Sb/Br)	CU NIPDAU	Level-1-260C-UNLIM	-40 to 105	D8534I	Samples
DAC8534IPWRG4	ACTIVE	TSSOP	PW	16	2000	Green (RoHS & no Sb/Br)	CU NIPDAU	Level-1-260C-UNLIM	-40 to 105	D8534I	Samples

(1) The marketing status values are defined as follows:

ACTIVE: Product device recommended for new designs.

LIFEBUY: TI has announced that the device will be discontinued, and a lifetime-buy period is in effect.

NRND: Not recommended for new designs. Device is in production to support existing customers, but TI does not recommend using this part in a new design.

PREVIEW: Device has been announced but is not in production. Samples may or may not be available.

OBSOLETE: TI has discontinued the production of the device.

(2) Eco Plan - The planned eco-friendly classification: Pb-Free (RoHS), Pb-Free (RoHS Exempt), or Green (RoHS & no Sb/Br) - please check <http://www.ti.com/productcontent> for the latest availability information and additional product content details.

TBD: The Pb-Free/Green conversion plan has not been defined.

Pb-Free (RoHS): TI's terms "Lead-Free" or "Pb-Free" mean semiconductor products that are compatible with the current RoHS requirements for all 6 substances, including the requirement that lead not exceed 0.1% by weight in homogeneous materials. Where designed to be soldered at high temperatures, TI Pb-Free products are suitable for use in specified lead-free processes.

Pb-Free (RoHS Exempt): This component has a RoHS exemption for either 1) lead-based flip-chip solder bumps used between the die and package, or 2) lead-based die adhesive used between the die and leadframe. The component is otherwise considered Pb-Free (RoHS compatible) as defined above.

Green (RoHS & no Sb/Br): TI defines "Green" to mean Pb-Free (RoHS compatible), and free of Bromine (Br) and Antimony (Sb) based flame retardants (Br or Sb do not exceed 0.1% by weight in homogeneous material)

(3) MSL, Peak Temp. -- The Moisture Sensitivity Level rating according to the JEDEC industry standard classifications, and peak solder temperature.

(4) Multiple Top-Side Markings will be inside parentheses. Only one Top-Side Marking contained in parentheses and separated by a "~" will appear on a device. If a line is indented then it is a continuation of the previous line and the two combined represent the entire Top-Side Marking for that device.

Important Information and Disclaimer: The information provided on this page represents TI's knowledge and belief as of the date that it is provided. TI bases its knowledge and belief on information provided by third parties, and makes no representation or warranty as to the accuracy of such information. Efforts are underway to better integrate information from third parties. TI has taken and continues to take reasonable steps to provide representative and accurate information but may not have conducted destructive testing or chemical analysis on incoming materials and chemicals. TI and TI suppliers consider certain information to be proprietary, and thus CAS numbers and other limited information may not be available for release.

In no event shall TI's liability arising out of such information exceed the total purchase price of the TI part(s) at issue in this document sold by TI to Customer on an annual basis.

TAPE AND REEL INFORMATION



QUADRANT ASSIGNMENTS FOR PIN 1 ORIENTATION IN TAPE



*All dimensions are nominal

Device	Package Type	Package Drawing	Pins	SPQ	Reel Diameter (mm)	Reel Width W1 (mm)	A0 (mm)	B0 (mm)	K0 (mm)	P1 (mm)	W (mm)	Pin1 Quadrant
DAC8534IPWR	TSSOP	PW	16	2000	330.0	12.4	6.9	5.6	1.6	8.0	12.0	Q1

TAPE AND REEL BOX DIMENSIONS



*All dimensions are nominal

Device	Package Type	Package Drawing	Pins	SPQ	Length (mm)	Width (mm)	Height (mm)
DAC8534IPWR	TSSOP	PW	16	2000	350.0	350.0	43.0



4220204/A 02/2017

NOTES:

1. All linear dimensions are in millimeters. Any dimensions in parenthesis are for reference only. Dimensioning and tolerancing per ASME Y14.5M.
2. This drawing is subject to change without notice.
3. This dimension does not include mold flash, protrusions, or gate burrs. Mold flash, protrusions, or gate burrs shall not exceed 0.15 mm per side.
4. This dimension does not include interlead flash. Interlead flash shall not exceed 0.25 mm per side.
5. Reference JEDEC registration MO-153.

EXAMPLE BOARD LAYOUT

PW0016A

TSSOP - 1.2 mm max height

SMALL OUTLINE PACKAGE



LAND PATTERN EXAMPLE
EXPOSED METAL SHOWN
SCALE: 10X



4220204/A 02/2017

NOTES: (continued)

- 6. Publication IPC-7351 may have alternate designs.
- 7. Solder mask tolerances between and around signal pads can vary based on board fabrication site.

EXAMPLE STENCIL DESIGN

PW0016A

TSSOP - 1.2 mm max height

SMALL OUTLINE PACKAGE



SOLDER PASTE EXAMPLE
BASED ON 0.125 mm THICK STENCIL
SCALE: 10X

4220204/A 02/2017

NOTES: (continued)

8. Laser cutting apertures with trapezoidal walls and rounded corners may offer better paste release. IPC-7525 may have alternate design recommendations.
9. Board assembly site may have different recommendations for stencil design.

IMPORTANT NOTICE AND DISCLAIMER

TI PROVIDES TECHNICAL AND RELIABILITY DATA (INCLUDING DATASHEETS), DESIGN RESOURCES (INCLUDING REFERENCE DESIGNS), APPLICATION OR OTHER DESIGN ADVICE, WEB TOOLS, SAFETY INFORMATION, AND OTHER RESOURCES "AS IS" AND WITH ALL FAULTS, AND DISCLAIMS ALL WARRANTIES, EXPRESS AND IMPLIED, INCLUDING WITHOUT LIMITATION ANY IMPLIED WARRANTIES OF MERCHANTABILITY, FITNESS FOR A PARTICULAR PURPOSE OR NON-INFRINGEMENT OF THIRD PARTY INTELLECTUAL PROPERTY RIGHTS.

These resources are intended for skilled developers designing with TI products. You are solely responsible for (1) selecting the appropriate TI products for your application, (2) designing, validating and testing your application, and (3) ensuring your application meets applicable standards, and any other safety, security, or other requirements. These resources are subject to change without notice. TI grants you permission to use these resources only for development of an application that uses the TI products described in the resource. Other reproduction and display of these resources is prohibited. No license is granted to any other TI intellectual property right or to any third party intellectual property right. TI disclaims responsibility for, and you will fully indemnify TI and its representatives against, any claims, damages, costs, losses, and liabilities arising out of your use of these resources.

TI's products are provided subject to TI's Terms of Sale (www.ti.com/legal/termsofsale.html) or other applicable terms available either on ti.com or provided in conjunction with such TI products. TI's provision of these resources does not expand or otherwise alter TI's applicable warranties or warranty disclaimers for TI products.

Mailing Address: Texas Instruments, Post Office Box 655303, Dallas, Texas 75265
Copyright © 2019, Texas Instruments Incorporated

Looking for pricing, stock, or lifecycle information?

Click below to explore more details on WIN SOURCE:

 [View DAC8534IPWR on WIN SOURCE](#)

 [Texas Instruments](#) Information

Optimize Your Supply Chain with WIN SOURCE Solutions

-  Global Sourcing Solution
-  Obsolete Management
-  Cost Control Management
-  Shortage Management
-  Alternative Solution
-  Excess Inventory Management