



**THE DATASHEET OF
AD5762RCSUZ-REEL7**



FEATURES

- Complete dual, 16-bit, digital-to-analog converter (DAC)
- Programmable output range: ± 10 V, ± 10.2564 V, or ± 10.5263 V
- ± 1 LSB maximum INL error, ± 1 LSB maximum DNL error
- Low noise: 60 nV/ $\sqrt{\text{Hz}}$
- Settling time: 10 μs maximum
- Integrated reference buffers
- Internal reference: 10 ppm/ $^{\circ}\text{C}$ maximum
- On-chip die temperature sensor
- Output control during power-up/brownout
- Programmable short-circuit protection
- Simultaneous updating via LDAC
- Asynchronous CLR to zero code
- Digital offset and gain adjust
- Logic output control pins
- DSP-/microcontroller-compatible serial interface
- Temperature range: -40°C to $+85^{\circ}\text{C}$
- Industrial complementary metal-oxide semiconductor (iCMOS) process technology

APPLICATIONS

- Industrial automation
- Open-loop/closed-loop servo control
- Process control
- Data acquisition systems
- Automatic test equipment
- Automotive test and measurement
- High accuracy instrumentation

GENERAL DESCRIPTION

The AD5762R is a dual, 16-bit, serial input, bipolar voltage output DAC that operates from supply voltages of ± 11.4 V to ± 16.5 V. Nominal full-scale output range is ± 10 V. The AD5762R provides integrated output amplifiers, reference buffers, and proprietary power-up/power-down control circuitry. The device also features a digital input/output port, programmed via the serial interface, and an analog temperature sensor. The device incorporates digital offset and gain adjust registers per channel.

The AD5762R is a high performance converter that provides guaranteed monotonicity, an integral nonlinearity (INL) of ± 1 LSB, low noise, and a 10 μs settling time. The AD5762R includes an on-chip 5 V reference with a reference temperature coefficient of 10 ppm/ $^{\circ}\text{C}$ maximum. During power-up when the supply voltages are changing, VOUTx is clamped to 0 V via a low impedance path.

The AD5762R is based on the iCMOS[®] technology platform, which is designed for analog systems designers within industrial/instrumentation equipment original equipment manufacturers (OEMs) who need high performance ICs at higher voltage levels. iCMOS enables the development of analog ICs capable of 30 V and operation at ± 15 V supplies, while allowing reductions in power consumption and package size coupled with increased ac and dc performance.

The AD5762R uses a serial interface that operates at clock rates of up to 30 MHz and is compatible with DSP and microcontroller interface standards. Double buffering allows the simultaneous updating of all DACs. The input coding is programmable to either twos complement or offset binary formats. The asynchronous clear function clears all DAC registers to either bipolar zero or zero scale, depending on the coding used. The AD5762R is ideal for both closed-loop servo control and open-loop control applications. The AD5762R is available in a 32-lead TQFP and offers guaranteed specifications over the -40°C to $+85^{\circ}\text{C}$ industrial temperature range (see Figure 1 for the functional block diagram).

TABLE OF CONTENTS

Features	1	Function Register	24
Applications	1	Data Register	25
General Description	1	Coarse Gain Register	25
Revision History	2	Fine Gain Register	25
Functional Block Diagram	3	Offset Register	26
Specifications	4	Offset and Gain Adjustment Worked Example	26
AC Performance Characteristics	6	Design Features	27
Timing Characteristics	7	Analog Output Control	27
Absolute Maximum Ratings	10	Digital Offset and Gain Control	27
Thermal Resistance	10	Programmable Short-Circuit Protection	27
ESD Caution	10	Digital I/O Port	27
Pin Configuration and Function Descriptions	11	Die Temperature Sensor	27
Typical Performance Characteristics	13	Local Ground Offset Adjust	27
Terminology	19	Applications Information	28
Theory of Operation	21	Typical Operating Circuit	28
DAC Architecture	21	Layout Guidelines	30
Reference Buffers	21	Galvanically Isolated Interface	30
Serial Interface	21	Microprocessor Interfacing	30
Simultaneous Updating via $\overline{\text{LDAC}}$	22	Evaluation Board	31
Transfer Function	23	Outline Dimensions	32
Asynchronous Clear ($\overline{\text{CLR}}$)	23	Ordering Guide	32
Registers	24		

REVISION HISTORY

6/2016—Rev. C to Rev. D

Changes to Table 7 and Table 8	23
--------------------------------------	----

9/2011—Rev. B to Rev. C

Changed 50 MHz to 30 MHz Throughout	1
Changes to t_1 , t_2 , and t_3 Parameters, Table 3	7

7/2011—Rev. A to Rev. B

Changed 30 MHz to 50 MHz Throughout	1
Changes to t_1 , t_2 , and t_3 Parameters, Table 3	7

8/2009—Rev. 0 to Rev. A

Deleted Endnote 1, Table 1	4
Deleted Endnote 1, Table 2	6
Deleted Endnote 1, Table 3	7
Changes to t_6 Parameter, Table 3	7

12/2008—Revision 0: Initial Version

FUNCTIONAL BLOCK DIAGRAM

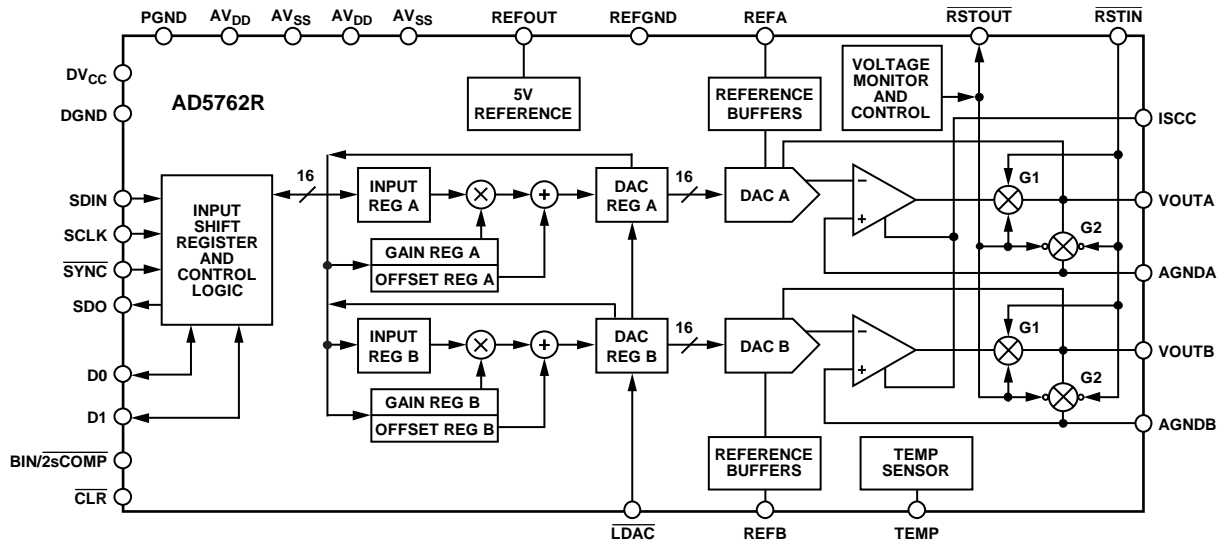

Figure 1.

07248-001

SPECIFICATIONS

$AV_{DD} = 11.4\text{ V to }16.5\text{ V}$, $AV_{SS} = -11.4\text{ V to }-16.5\text{ V}$, $AGND = DGND = REFGND = PGND = 0\text{ V}$; $REFA = REFB = 5\text{ V}$ external;
 $DV_{CC} = 2.7\text{ V to }5.25\text{ V}$, $R_{LOAD} = 10\text{ k}\Omega$, $C_L = 200\text{ pF}$. All specifications T_{MIN} to T_{MAX} , unless otherwise noted.

Table 1.

Parameter	Min	Typ	Max	Unit	Test Conditions/Comments ¹
ACCURACY					
Resolution	16			Bits	Outputs unloaded
Relative Accuracy (INL)	-1		+1	LSB	
Differential Nonlinearity (DNL)	-1		+1	LSB	Guaranteed monotonic
Bipolar Zero Error	-2		+2	mV	25°C; error at other temperatures obtained using bipolar zero tempco
Bipolar Zero Tempco ²	-3		+3	mV	
Zero-Scale Error	-2		+2	ppm FSR/°C	25°C; error at other temperatures obtained using zero-scale tempco
Zero-Scale Tempco ²	-2.5		+2.5	mV	
Gain Error	-2		+2	ppm FSR/°C	
Gain Tempco ²	-0.02		+0.02	% FSR	
DC Crosstalk ²	-2		+2	ppm FSR/°C	
DC Crosstalk ²			0.5	LSB	
REFERENCE INPUT/OUTPUT					
Reference Input ²					
Reference Input Voltage		5		V	±1% for specified performance
DC Input Impedance	1	100		MΩ	
Input Current	-10	±0.03	+10	μA	
Reference Range	1		7	V	
Reference Output					
Output Voltage	4.995	5	5.005	V	25°C, $AV_{DD}/AV_{SS} = \pm 13.5\text{ V}$
Reference Tempco ²	-10	±1.7	+10	ppm/°C	
R_{LOAD} ²	1			MΩ	
Power Supply Sensitivity ²		300		μV/V	
Output Noise ²		18		μV p-p	0.1 Hz to 10 Hz
Noise Spectral Density ²		75		nV/√Hz	10 kHz
Output Voltage Drift vs. Time ²		±40		ppm/500 hr	
		±50		ppm/1000 hr	
Thermal Hysteresis ²		70		ppm	First temperature cycle
		30		ppm	Subsequent temperature cycles
OUTPUT CHARACTERISTICS²					
Output Voltage Range ³	-10.5263		+10.5263	V	$AV_{DD}/AV_{SS} = \pm 11.4\text{ V}$, $REFA = REFB = 5\text{ V}$
	-14.7368		+14.7368	V	$AV_{DD}/AV_{SS} = \pm 16.5\text{ V}$, $REFA = REFB = 7\text{ V}$
Output Voltage Drift vs. Time		±13		ppm FSR/ 500 hr	
		±15		ppm FSR/ 1000 hr	
Short-Circuit Current		10		mA	$R_{ISCC} = 6\text{ k}\Omega$, see Figure 31
Load Current	-1		+1	mA	For specified performance
Capacitive Load Stability					
$R_{LOAD} = \infty$			200	pF	
$R_{LOAD} = 10\text{ k}\Omega$			1000	pF	
DC Output Impedance			0.3	Ω	

Parameter	Min	Typ	Max	Unit	Test Conditions/Comments ¹
DIGITAL INPUTS²					
Input High Voltage, V_{IH}	2.4			V	$DV_{CC} = 2.7\text{ V to } 5.25\text{ V}$
Input Low Voltage, V_{IL}			0.8	V	
Input Current	-1.2		+1.2	μA	Per pin
Pin Capacitance			10	pF	Per pin
DIGITAL OUTPUTS (D0, D1, SDO)²					
Output Low Voltage			0.4	V	$DV_{CC} = 5\text{ V} \pm 5\%$, sinking 200 μA
Output High Voltage	$DV_{CC} - 1$			V	$DV_{CC} = 5\text{ V} \pm 5\%$, sourcing 200 μA
Output Low Voltage			0.4	V	$DV_{CC} = 2.7\text{ V to } 3.6\text{ V}$, sinking 200 μA
Output High Voltage	$DV_{CC} - 0.5$			V	$DV_{CC} = 2.7\text{ V to } 3.6\text{ V}$, sourcing 200 μA
High Impedance Leakage Current	-1		+1	μA	SDO only
High Impedance Output Capacitance		5		pF	SDO only
DIE TEMPERATURE SENSOR²					
Output Voltage at 25°C		1.47		V	Die temperature
Output Voltage Scale Factor		5		mV/°C	
Output Voltage Range	1.175		1.9	V	-40°C to +105°C
Output Load Current			200	μA	Current source only
Power-On Time		80		ms	
POWER REQUIREMENTS					
AV_{DD}	+11.4		+16.5	V	
AV_{SS}	-16.5		-11.4	V	
DV_{CC}	2.7		5.25	V	
Power Supply Sensitivity ²					
$\Delta V_{OUT}/\Delta AV_{DD}$		-85		dB	
AI_{DD}			4.25	mA/channel	Outputs unloaded
AI_{SS}			3.9	mA/channel	Outputs unloaded
DI_{CC}			1.2	mA	$V_{IH} = DV_{CC}$, $V_{IL} = DGND$, 750 μA typ
Power Dissipation		180		mW	$\pm 12\text{ V}$ operation output unloaded

¹ Temperature range: -40°C to +85°C; typical at +25°C. Device functionality is guaranteed to +105°C with degraded performance.

² Guaranteed by design and characterization; not production tested.

³ Output amplifier headroom requirement is 1.4 V minimum.

AC PERFORMANCE CHARACTERISTICS

$AV_{DD} = 11.4\text{ V to }16.5\text{ V}$, $AV_{SS} = -11.4\text{ V to }-16.5\text{ V}$, $AGND = DGND = REFGND = PGND = 0\text{ V}$; REFA, REFB= 5 V external;
 $DV_{CC} = 2.7\text{ V to }5.25\text{ V}$, $R_{LOAD} = 10\text{ k}\Omega$, $C_L = 200\text{ pF}$. All specifications T_{MIN} to T_{MAX} , unless otherwise noted.

Table 2.

Parameter	Min	Typ	Max	Unit	Test Conditions/Comments
DYNAMIC PERFORMANCE¹					
Output Voltage Settling Time		8	10	μs	Full-scale step to $\pm 1\text{ LSB}$
		2		μs	512 LSB step settling
Slew Rate		5		$\text{V}/\mu\text{s}$	
Digital-to-Analog Glitch Energy		8		$\text{nV}\cdot\text{sec}$	
Glitch Impulse Peak Amplitude			25	mV	
Channel-to-Channel Isolation		80		dB	
DAC-to-DAC Crosstalk		8		$\text{nV}\cdot\text{sec}$	
Digital Crosstalk		2		$\text{nV}\cdot\text{sec}$	
Digital Feedthrough		2		$\text{nV}\cdot\text{sec}$	Effect of input bus activity on DAC outputs
Output Noise (0.1 Hz to 10 Hz)		0.1		LSB p-p	
Output Noise (0.1 Hz to 100 kHz)			45	$\mu\text{V rms}$	
1/f Corner Frequency		1		kHz	
Output Noise Spectral Density		60		$\text{nV}/\sqrt{\text{Hz}}$	Measured at 10 kHz
Complete System Output Noise Spectral Density ²		80		$\text{nV}/\sqrt{\text{Hz}}$	Measured at 10 kHz

¹ Guaranteed by design and characterization; not production tested.

² Includes noise contributions from integrated reference buffers, 16-bit DAC, and output amplifier.

TIMING CHARACTERISTICS

$AV_{DD} = 11.4\text{ V to }16.5\text{ V}$, $AV_{SS} = -11.4\text{ V to }-16.5\text{ V}$, $AGND = DGND = REFGND = PGND = 0\text{ V}$; $REFA = REFB = 5\text{ V external}$;
 $DV_{CC} = 2.7\text{ V to }5.25\text{ V}$, $R_{LOAD} = 10\text{ k}\Omega$, $C_L = 200\text{ pF}$. All specifications T_{MIN} to T_{MAX} , unless otherwise noted.

Table 3.

Parameter ^{1, 2, 3}	Limit at T_{MIN}, T_{MAX}	Unit	Description
t_1	33	ns min	SCLK cycle time
t_2	13	ns min	SCLK high time
t_3	13	ns min	SCLK low time
t_4	13	ns min	\overline{SYNC} falling edge to SCLK falling edge setup time
t_5^4	13	ns min	24 th SCLK falling edge to \overline{SYNC} rising edge
t_6	90	ns min	Minimum \overline{SYNC} high time
t_7	2	ns min	Data setup time
t_8	5	ns min	Data hold time
t_9	1.7	$\mu\text{s min}$	\overline{SYNC} rising edge to \overline{LDAC} falling edge (all DACs updated)
	480	ns min	\overline{SYNC} rising edge to \overline{LDAC} falling edge (single DAC updated)
t_{10}	10	ns min	\overline{LDAC} pulse width low
t_{11}	500	ns max	\overline{LDAC} falling edge to DAC output response time
t_{12}	10	$\mu\text{s max}$	DAC output settling time
t_{13}	10	ns min	\overline{CLR} pulse width low
t_{14}	2	$\mu\text{s max}$	\overline{CLR} pulse activation time
$t_{15}^{5, 6}$	25	ns max	SCLK rising edge to SDO valid
t_{16}	13	ns min	\overline{SYNC} rising edge to SCLK falling edge
t_{17}	2	$\mu\text{s max}$	\overline{SYNC} rising edge to DAC output response time ($\overline{LDAC} = 0$)
t_{18}	170	ns min	\overline{LDAC} falling edge to \overline{SYNC} rising edge

¹ Guaranteed by design and characterization; not production tested.

² All input signals are specified with $t_r = t_f = 5\text{ ns}$ (10% to 90% of DV_{CC}) and timed from a voltage level of 1.2 V.

³ See Figure 2, Figure 3, and Figure 4.

⁴ Standalone mode only.

⁵ Measured with the load circuit of Figure 5.

⁶ Daisy-chain mode only.

Timing Diagrams

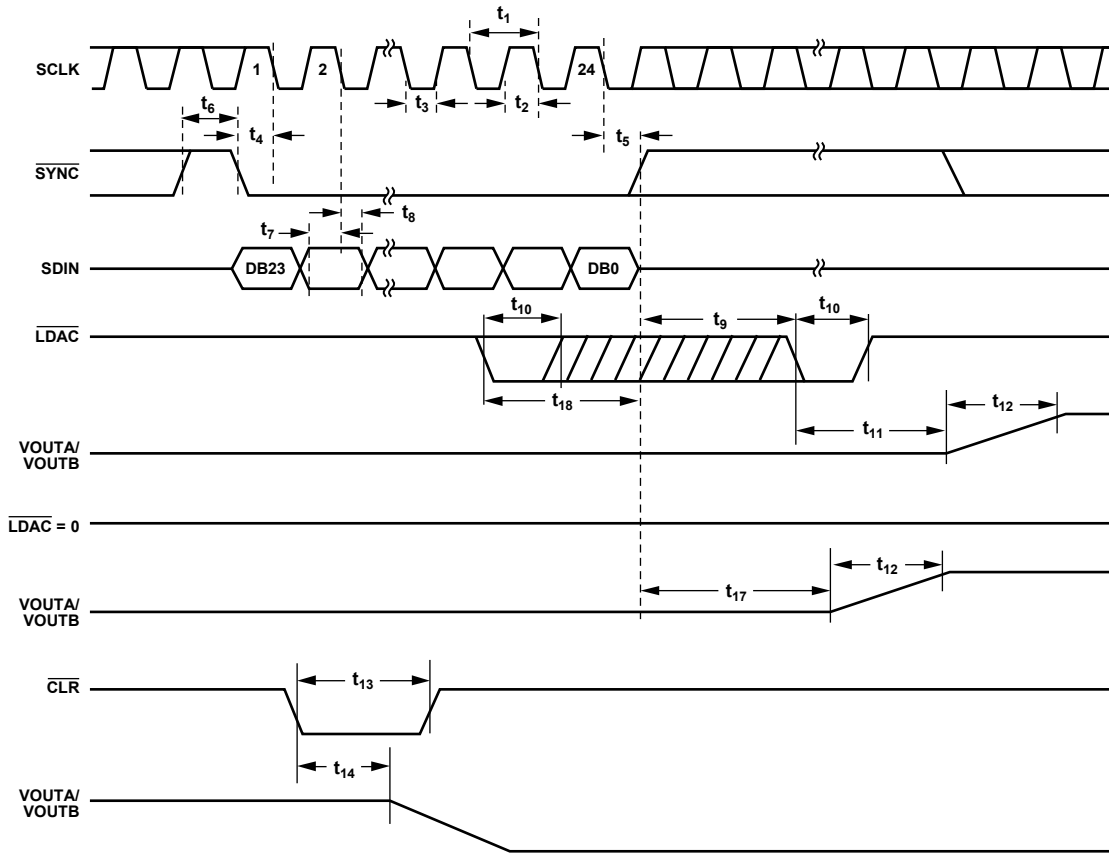

07248-002

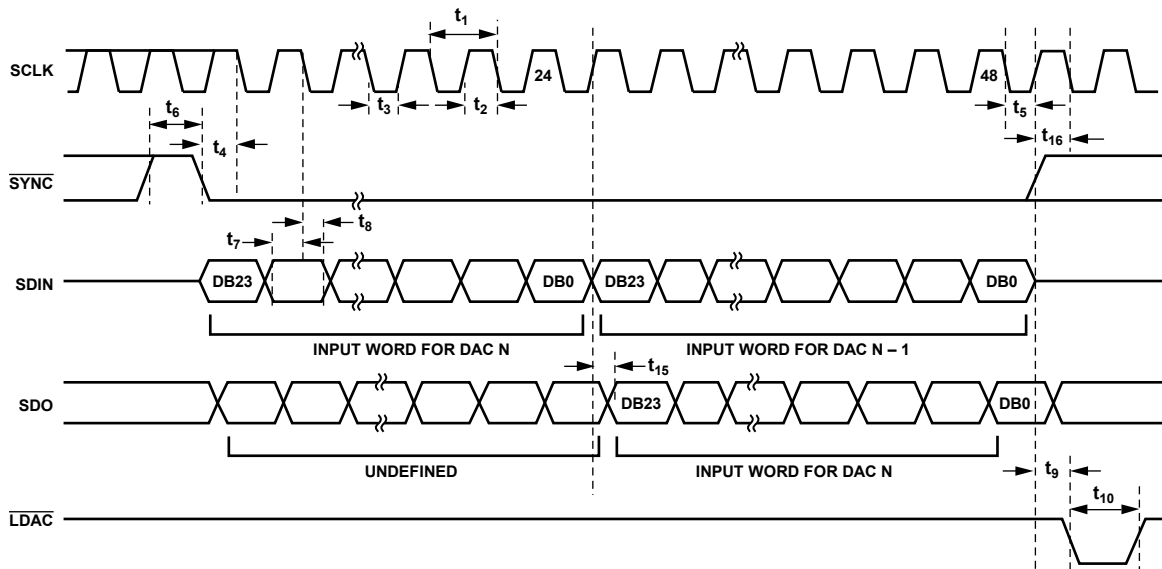

07248-003

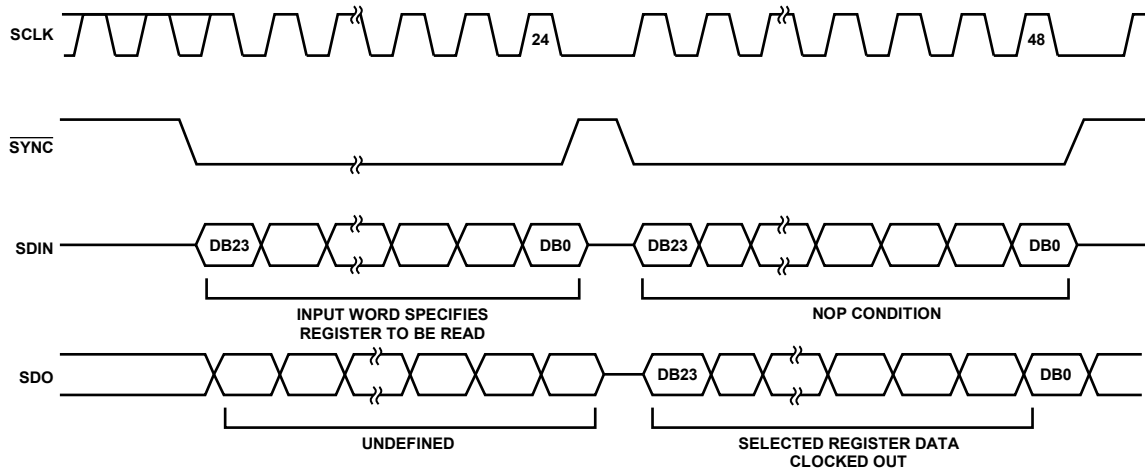

07248-004

Figure 4. Readback Timing Diagram

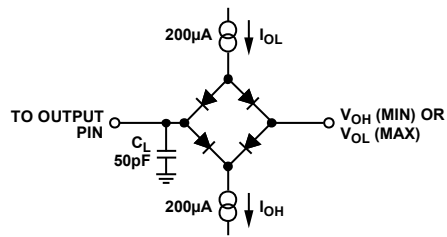

07248-005

Figure 5. Load Circuit for SDO Timing Diagram

ABSOLUTE MAXIMUM RATINGS

$T_A = 25^\circ\text{C}$ unless, otherwise noted. Transient currents of up to 100 mA do not cause SCR latch-up.

Table 4.

Parameter	Rating
AV_{DD} to AGND, DGND	-0.3 V to +17 V
AV_{SS} to AGND, DGND	+0.3 V to -17 V
DV_{CC} to DGND	-0.3 V to +7 V
Digital Inputs to DGND	-0.3 V to ($DV_{CC} + 0.3$ V) or +7 V, whichever is less
Digital Outputs to DGND	-0.3 V to $DV_{CC} + 0.3$ V
REFx to AGND, PGND	-0.3 V to $AV_{DD} + 0.3$ V
REFOUT to AGND	AV_{SS} to AV_{DD}
TEMP	AV_{SS} to AV_{DD}
VOUtx to AGND	AV_{SS} to AV_{DD}
AGND to DGND	-0.3 V to +0.3 V
Operating Temperature Range Industrial	-40°C to +85°C
Storage Temperature Range	-65°C to +150°C
Junction Temperature (T_J max)	150°C
Lead Temperature (Soldering)	JEDEC Industry Standard J-STD-020

Stresses at or above those listed under Absolute Maximum Ratings may cause permanent damage to the product. This is a stress rating only; functional operation of the product at these or any other conditions above those indicated in the operational section of this specification is not implied. Operation beyond the maximum operating conditions for extended periods may affect product reliability.

THERMAL RESISTANCE

θ_{JA} is specified for the worst-case conditions, that is, a device soldered in a circuit board for surface-mount packages.

Table 5. Thermal Resistance

Package Type	θ_{JA}	θ_{JC}	Unit
32-Lead TQFP	65	12	$^\circ\text{C}/\text{W}$

ESD CAUTION



ESD (electrostatic discharge) sensitive device. Charged devices and circuit boards can discharge without detection. Although this product features patented or proprietary protection circuitry, damage may occur on devices subjected to high energy ESD. Therefore, proper ESD precautions should be taken to avoid performance degradation or loss of functionality.

PIN CONFIGURATION AND FUNCTION DESCRIPTIONS

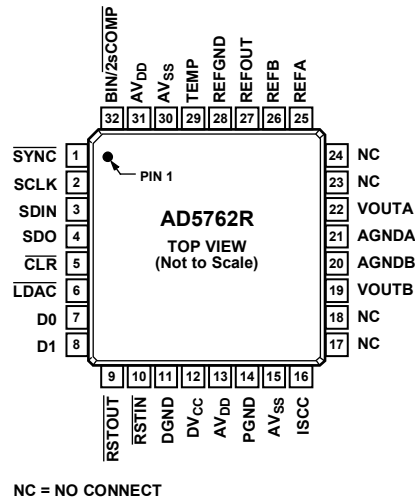

Figure 6. Pin Configuration

Table 6. Pin Function Descriptions

Pin No.	Mnemonic	Description
1	SYNC	Active Low Input. This is the frame synchronization signal for the serial interface. While SYNC is low, data is transferred in on the falling edge of SCLK.
2	SCLK	Serial Clock Input. Data is clocked into the shift register on the falling edge of SCLK. This operates at clock speeds of up to 30 MHz.
3	SDIN	Serial Data Input. Data must be valid on the falling edge of SCLK.
4	SDO	Serial Data Output. Used to clock data from the serial register in daisy-chain or readback mode.
5	CLR	Negative Edge Triggered Input. ¹ Asserting this pin sets the DAC registers to 0x0000.
6	LDAC	Load DAC. This logic input is used to update the DAC registers and, consequently, the analog outputs. When tied permanently low, the addressed DAC register is updated on the rising edge of SYNC. If LDAC is held high during the write cycle, the DAC input register is updated, but the output update is held off until the falling edge of LDAC. In this mode, all analog outputs can be updated simultaneously on the falling edge of LDAC. The LDAC pin must not be left unconnected.
7, 8	D0, D1	Digital I/O Port. D0 and D1 form a digital I/O port. The user can set up these pins as inputs or outputs that are configurable and readable over the serial interface. When configured as inputs, these pins have weak internal pull-ups to DV _{CC} . When programmed as outputs, D0 and D1 are referenced by DV _{CC} and DGND.
9	RSTOUT	Reset Logic Output. This is the output from the on-chip voltage monitor used in the reset circuit. If desired, it can be used to control other system components.
10	RSTIN	Reset Logic Input. This input allows external access to the internal reset logic. Applying a Logic 0 to this input clamps the DAC outputs to 0 V. In normal operation, RSTIN should be tied to Logic 1. Register values remain unchanged.
11	DGND	Digital Ground Pin.
12	DV _{CC}	Digital Supply Pin. Voltage ranges from 2.7 V to 5.25 V.
13, 31	AV _{DD}	Positive Analog Supply Pins. Voltage ranges from 11.4 V to 16.5 V.
14	PGND	Ground Reference Point for Analog Circuitry.
15, 30	AV _{SS}	Negative Analog Supply Pins. Voltage ranges from -11.4 V to -16.5 V.
16	ISCC	This pin is used in association with an optional external resistor to AGND to program the short-circuit current of the output amplifiers. Refer to the Design Features section for more information.
17	NC	Do not connect to this pin.
18	NC	Do not connect to this pin.
19	VOUTB	Analog Output Voltage of DAC B. Buffered output with a nominal full-scale output range of ±10 V. The output amplifier is capable of directly driving a 10 kΩ, 200 pF load.
20	AGNDB	Ground Reference Pin for DAC B Output Amplifier.
21	AGNDA	Ground Reference Pin for DAC A Output Amplifier.

Pin No.	Mnemonic	Description
22	VOUTA	Analog Output Voltage of DAC A. Buffered output with a nominal full-scale output range of ± 10 V. The output amplifier is capable of directly driving a 10 k Ω , 200 pF load.
23	NC	Do not connect to this pin.
24	NC	Do not connect to this pin.
25	REFA	External Reference Voltage. The reference input range is 1 V to 7 V, and it programs the full-scale output voltage. REFA = 5 V for specified performance.
26	REFB	External Reference Voltage. The reference input range is 1 V to 7 V, and it programs the full-scale output voltage. REFB = 5 V for specified performance.
27	REFOUT	Reference Output. This is the reference output from the internal voltage reference. The internal reference is 5 V \pm 3 mV at 25°C, with a reference temperature coefficient of 10 ppm/°C.
28	REFGND	Reference Ground Return for the Reference Generator and Buffers.
29	TEMP	This pin provides an output voltage proportional to temperature. The output voltage is 1.47 V typical at 25°C die temperature; variation with temperature is 5 mV/°C.
32	BIN/ $\overline{2sCOMP}$	This pin determines the DAC coding. This pin should be hardwired to either DV _{CC} or DGND. When hardwired to DV _{CC} , input coding is offset binary (see Table 7). When hardwired to DGND, input coding is twos complement (see Table 8).

¹ Internal pull-up device on this logic input. Therefore, it can be left floating and defaults to a logic high condition.

TYPICAL PERFORMANCE CHARACTERISTICS

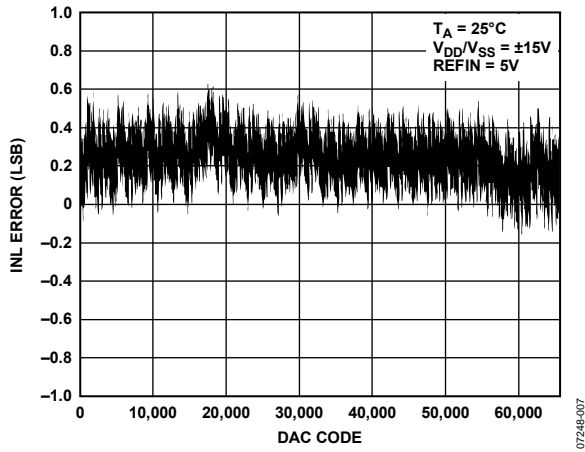

Figure 7. Integral Nonlinearity Error vs. DAC Code, $V_{DD}/V_{SS} = \pm 15 V$

07248-007

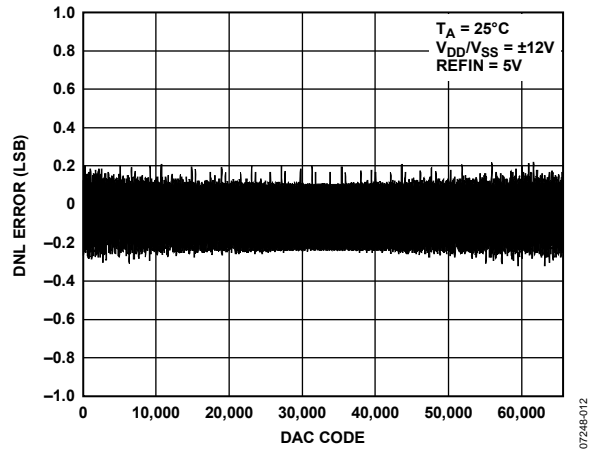

Figure 10. Differential Nonlinearity Error vs. DAC Code, $V_{DD}/V_{SS} = \pm 12 V$

07248-012

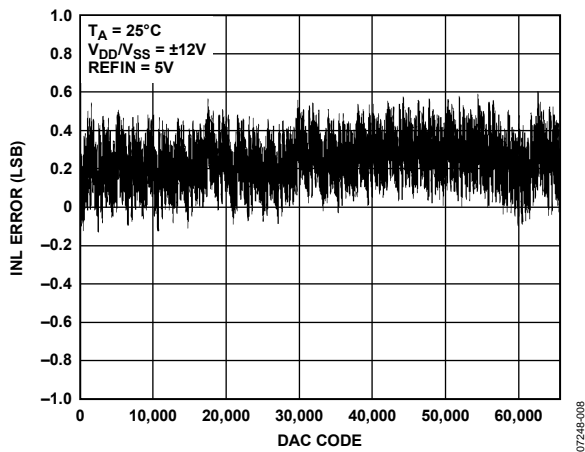

Figure 8. Integral Nonlinearity Error vs. DAC Code, $V_{DD}/V_{SS} = \pm 12 V$

07248-008

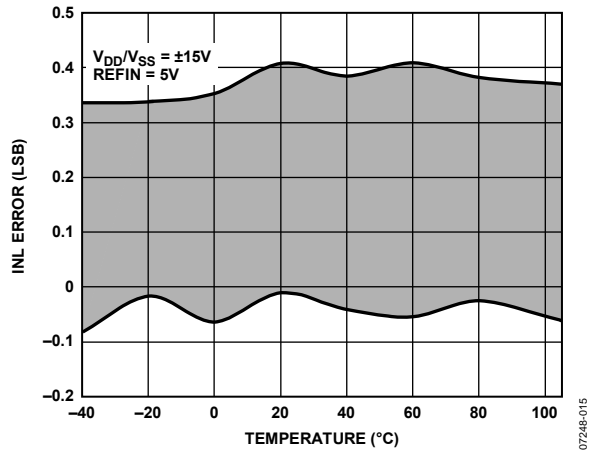

Figure 11. Integral Nonlinearity Error vs. Temperature, $V_{DD}/V_{SS} = \pm 15 V$

07248-015

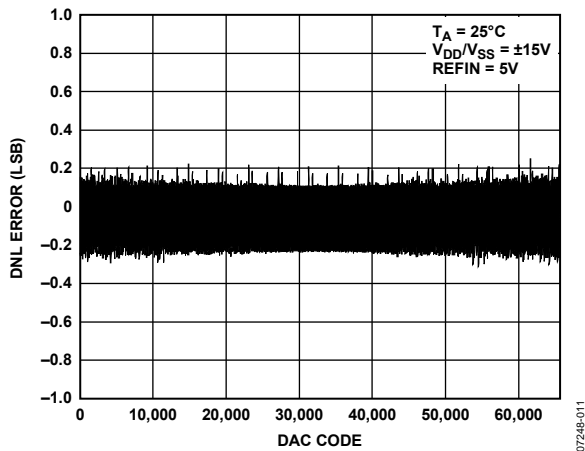

Figure 9. Differential Nonlinearity Error vs. DAC Code, $V_{DD}/V_{SS} = \pm 15 V$

07248-011

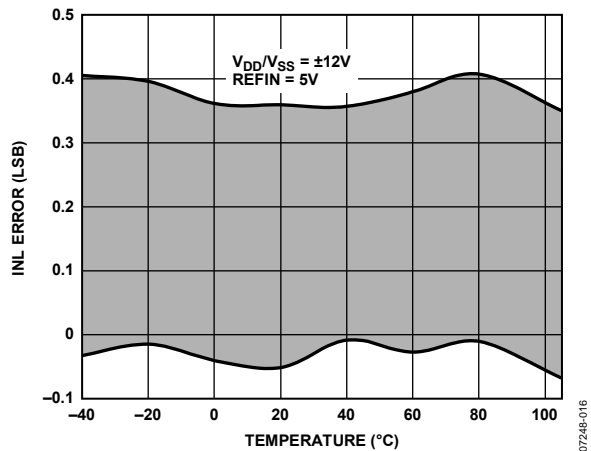

Figure 12. Integral Nonlinearity Error vs. Temperature, $V_{DD}/V_{SS} = \pm 12 V$

07248-016

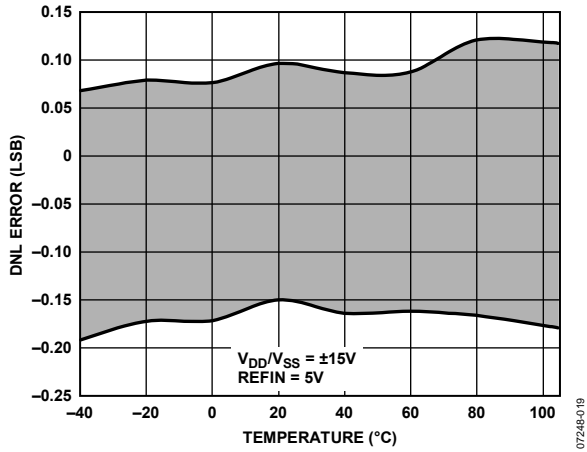

Figure 13. Differential Nonlinearity Error vs. Temperature, $V_{DD}/V_{SS} = \pm 15 V$

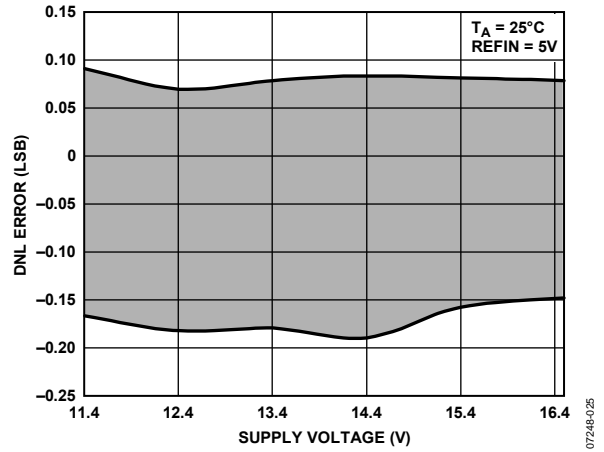

Figure 16. Differential Nonlinearity Error vs. Supply Voltage

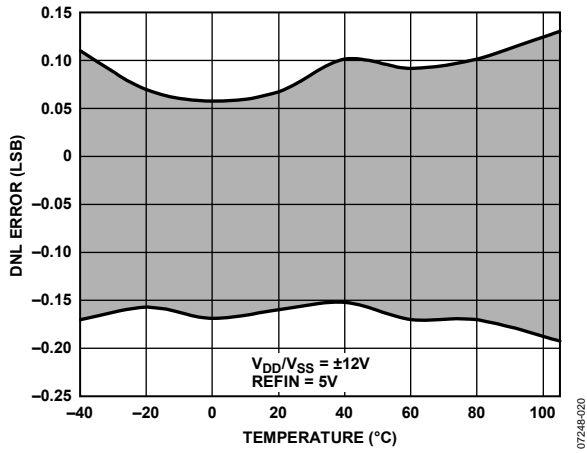

Figure 14. Differential Nonlinearity Error vs. Temperature, $V_{DD}/V_{SS} = \pm 12 V$

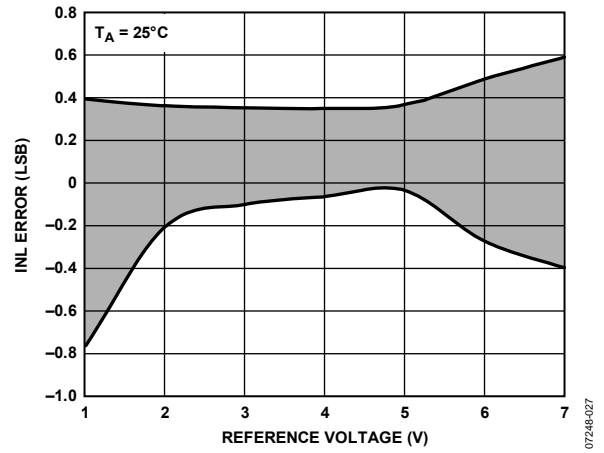

Figure 17. Integral Nonlinearity Error vs. Reference Voltage, $V_{DD}/V_{SS} = \pm 16.5 V$

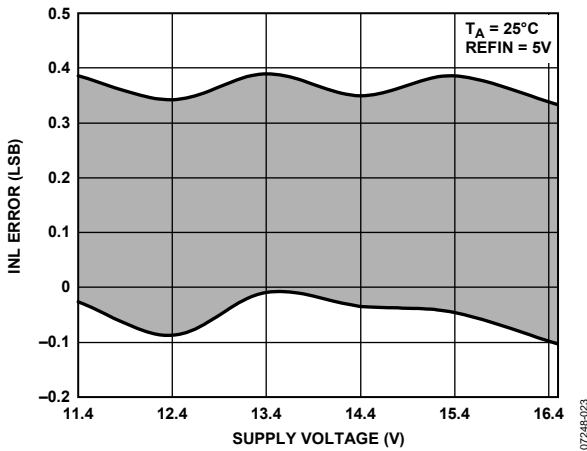

Figure 15. Integral Nonlinearity Error vs. Supply Voltage

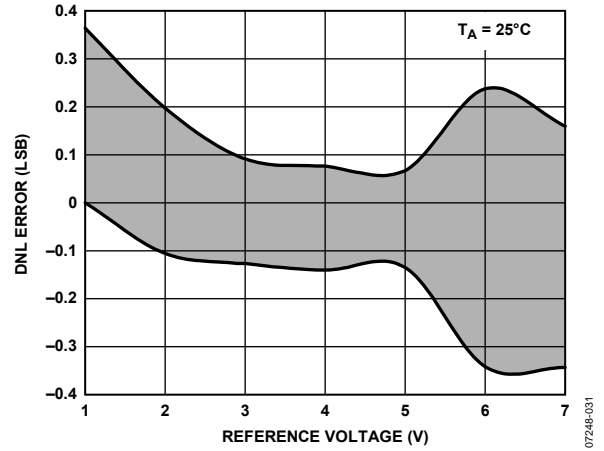

Figure 18. Differential Nonlinearity Error vs. Reference Voltage, $V_{DD}/V_{SS} = \pm 16.5 V$

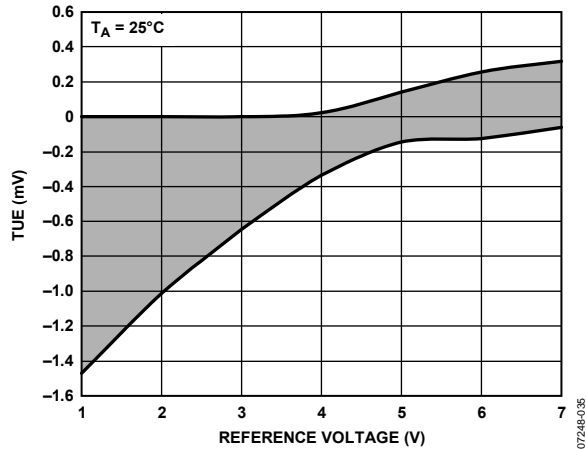

Figure 19. Total Unadjusted Error vs. Reference Voltage, $V_{DD}/V_{SS} = \pm 16.5 V$

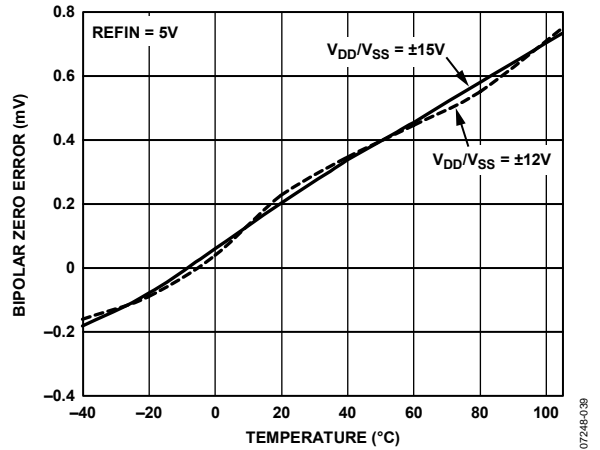

Figure 22. Bipolar Zero Error vs. Temperature

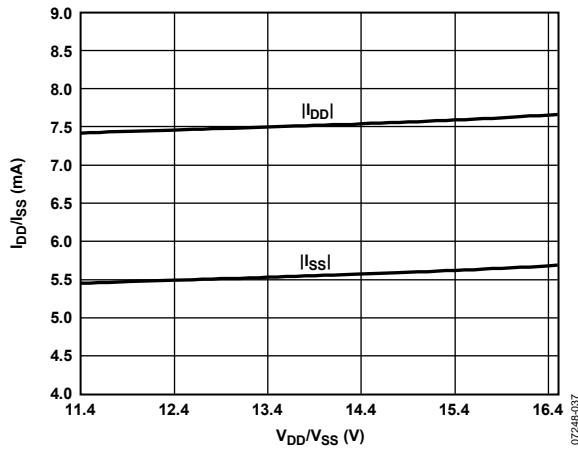

Figure 20. I_{DD}/I_{SS} vs. V_{DD}/V_{SS}

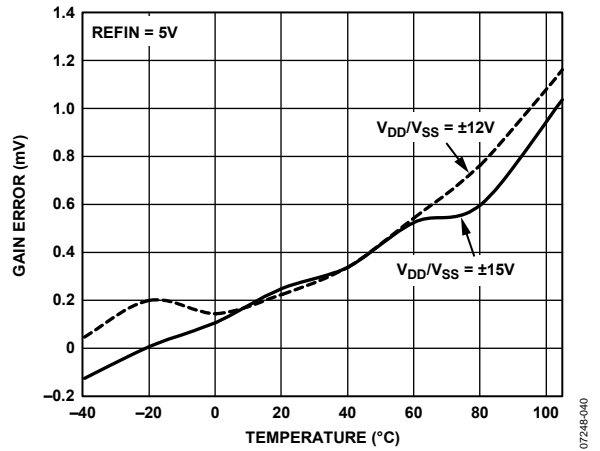

Figure 23. Gain Error vs. Temperature

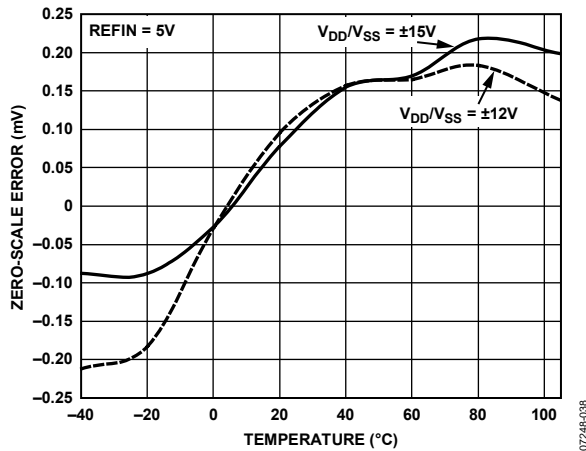

Figure 21. Zero-Scale Error vs. Temperature

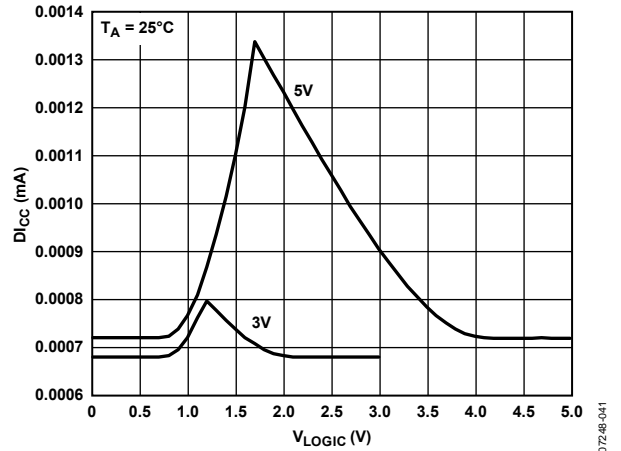

Figure 24. D_{Icc} vs. Logic Input Voltage

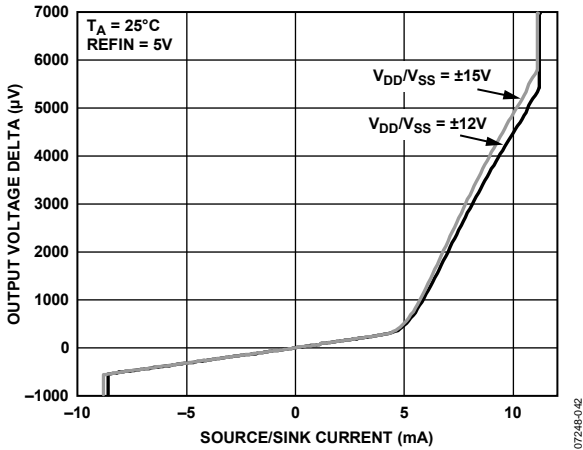

Figure 25. Source and Sink Capability of Output Amplifier with Positive Full Scale Loaded

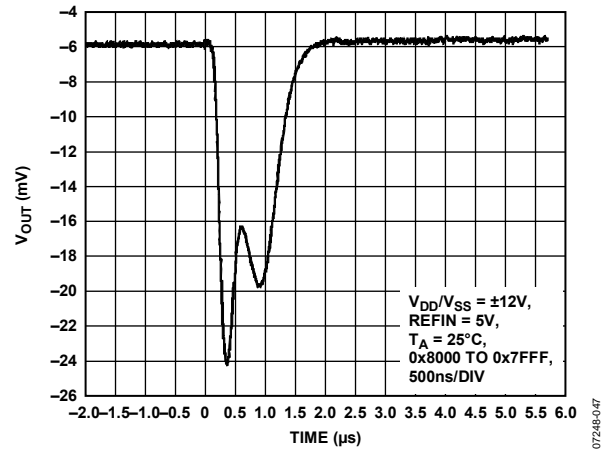

Figure 28. Major Code Transition Glitch Energy, $V_{DD}/V_{SS} = \pm 12 V$

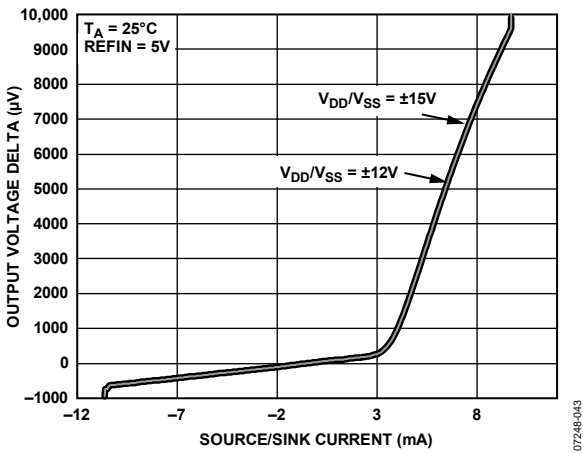

Figure 26. Source and Sink Capability of Output Amplifier with Negative Full Scale Loaded

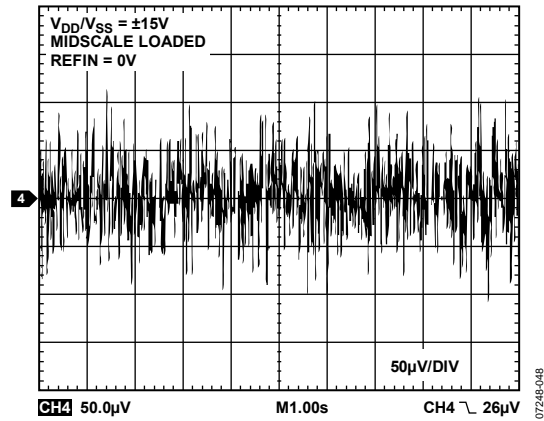

Figure 29. Peak-to-Peak Noise (100 kHz Bandwidth)

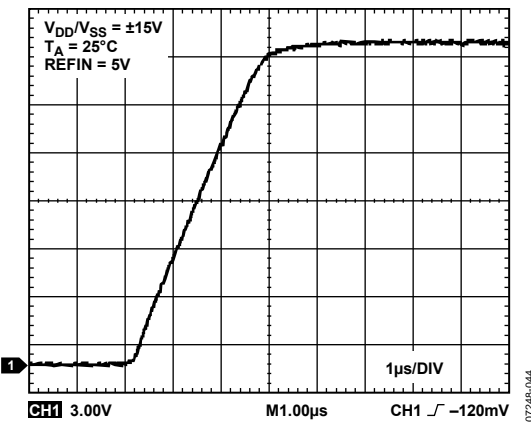

Figure 27. Full-Scale Settling Time

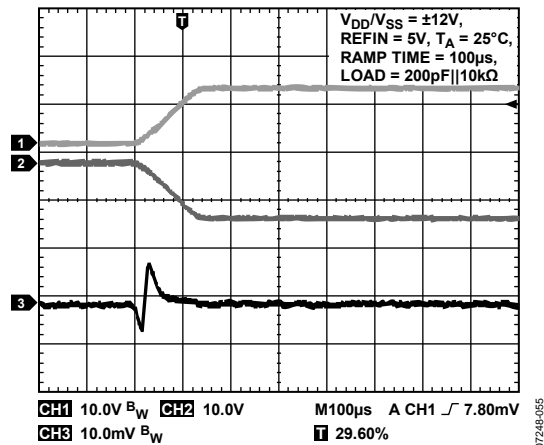

Figure 30. V_{OUTx} vs. V_{DD}/V_{SS} on Power-Up

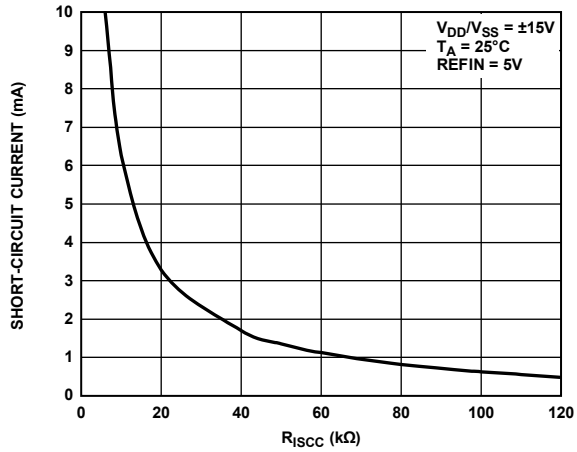

Figure 31. Short-Circuit Current vs. R_{isc}

0724E-050

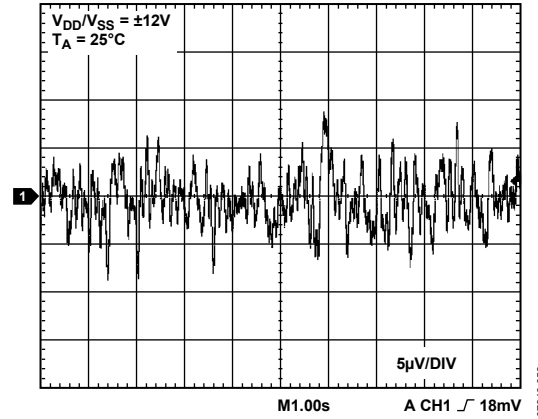

Figure 34. REFOUT Output Noise, 0.1 Hz to 10 Hz

0724E-053

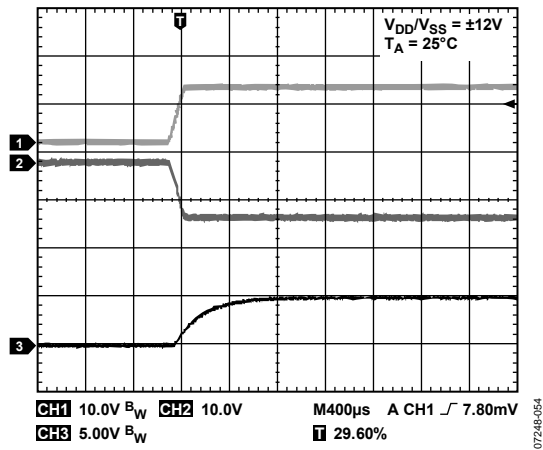

Figure 32. REFOUT Turn-On Transient

0724E-054

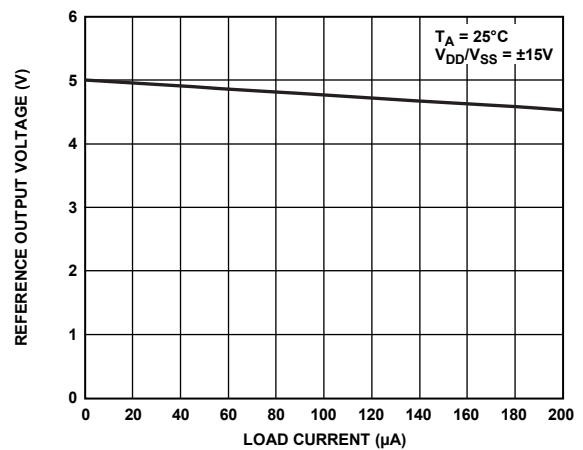

Figure 35. REFOUT Load Regulation

0724E-052

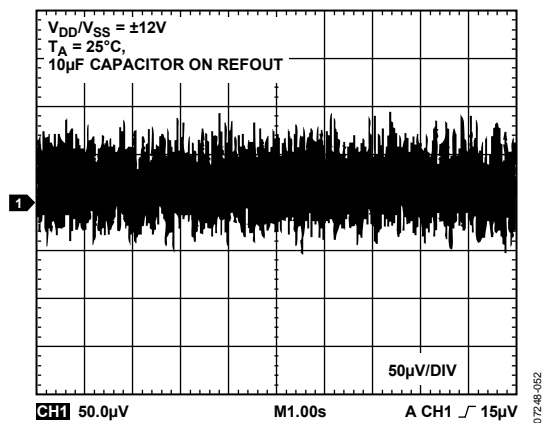

Figure 33. REFOUT Output Noise, 100 kHz Bandwidth

0724E-052

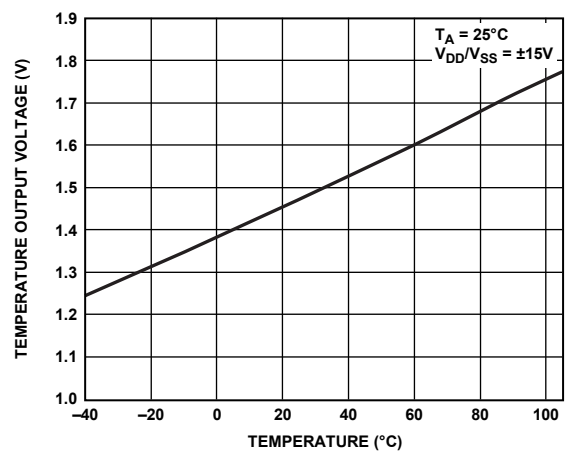

Figure 36. Temperature Output Voltage vs. Temperature

0724E-033

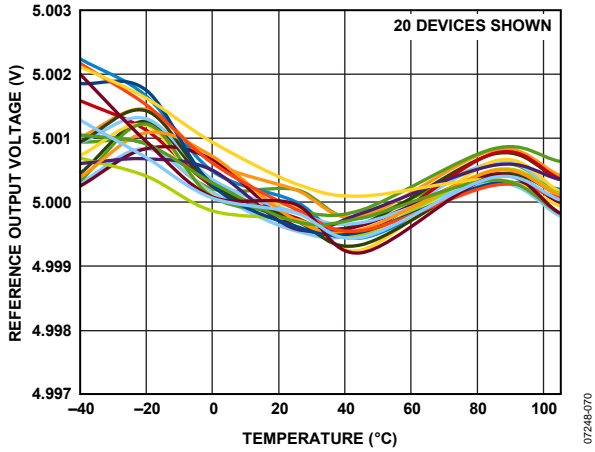

Figure 37. Reference Output Voltage vs. Temperature

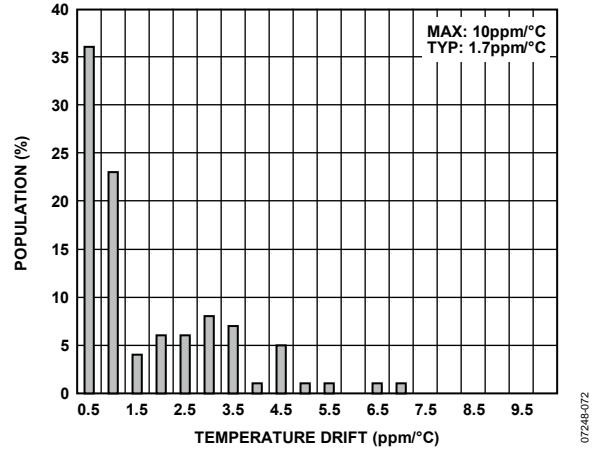

Figure 38. Reference Output Temperature Drift (-40°C to +85°C)

TERMINOLOGY

Relative Accuracy or Integral Nonlinearity (INL)

For the DAC, a measure of the maximum deviation, in LSBs, from a straight line passing through the endpoints of the DAC transfer function.

Differential Nonlinearity (DNL)

The difference between the measured change and the ideal 1 LSB change between any two adjacent codes. A specified differential nonlinearity of ± 1 LSB maximum ensures monotonicity. This DAC is guaranteed monotonic.

Monotonicity

A DAC is monotonic if the output either increases or remains constant for increasing digital input code. The AD5762R is monotonic over its full operating temperature range.

Bipolar Zero Error

The deviation of the analog output from the ideal half-scale output of 0 V when the DAC register is loaded with 0x8000 (offset binary coding) or 0x0000 (twos complement coding). Figure 22 shows a plot of bipolar zero error vs. temperature.

Bipolar Zero Temperature Coefficient

The measure of the change in the bipolar zero error with a change in temperature. It is expressed as parts per million of full-scale range per degree Celsius (ppm FSR/ $^{\circ}$ C).

Full-Scale Error

The measure of the output error when full-scale code is loaded to the DAC register. Ideally, the output voltage should be $2 \times V_{REFIN} - 1$ LSB. Full-scale error is expressed as a percentage of full-scale range (% FSR).

Negative Full-Scale Error/Zero-Scale Error

The error in the DAC output voltage when 0x0000 (offset binary coding) or 0x8000 (twos complement coding) is loaded to the DAC register. Ideally, the output voltage should be $-2 \times V_{REFIN}$. Figure 21 shows a plot of zero-scale error vs. temperature.

Output Voltage Settling Time

The amount of time it takes for the output to settle to a specified level for a full-scale input change.

Slew Rate

A limitation in the rate of change of the output voltage. The output slewing speed of a voltage-output DAC is usually limited by the slew rate of the amplifier used at its output. Slew rate is measured from 10% to 90% of the output signal and is given in volts per microsecond (V/ μ s).

Gain Error

A measure of the span error of the DAC. It is the deviation in slope of the DAC transfer characteristic from the ideal, expressed as a percentage of the full-scale range (% FSR). Figure 23 shows a plot of gain error vs. temperature.

Total Unadjusted Error (TUE)

A measure of the output error, considering all the various errors. Figure 19 shows a plot of total unadjusted error vs. reference voltage.

Zero-Scale Error Temperature Coefficient

A measure of the change in zero-scale error with a change in temperature. It is expressed as parts per million of full-scale range per degree Celsius (ppm FSR/ $^{\circ}$ C).

Gain Error Temperature Coefficient

A measure of the change in gain error with changes in temperature. It is expressed as parts per million of full-scale range per degree Celsius (ppm FSR/ $^{\circ}$ C).

Digital-to-Analog Glitch Energy

The impulse injected into the analog output when the input code in the DAC register changes state. It is normally specified as the area of the glitch in nanovolt-seconds (nV-sec) and is measured when the digital input code is changed by 1 LSB at the major carry transition (0x7FFF to 0x8000), as seen in Figure 28.

Digital Feedthrough

A measure of the impulse injected into the analog output of the DAC from the digital inputs of the DAC but is measured when the DAC output is not updated. It is specified in nanovolt-seconds (nV-sec) and measured with a full-scale code change on the data bus, that is, from all 0s to all 1s, and vice versa.

Power Supply Sensitivity

Indicates how the output of the DAC is affected by changes in the power supply voltage.

DC Crosstalk

The dc change in the output level of one DAC in response to a change in the output of another DAC. It is measured with a full-scale output change on one DAC while monitoring another DAC, and is expressed in least significant bits (LSBs).

DAC-to-DAC Crosstalk

The glitch impulse transferred to the output of one DAC due to a digital code change and subsequent output change of another DAC. This includes both digital and analog crosstalk. It is measured by loading one of the DACs with a full-scale code change (from all 0s to all 1s, and vice versa) with \overline{LDAC} low and monitoring the output of another DAC. The energy of the glitch is expressed in nanovolt-seconds (nV-sec).

Channel-to-Channel Isolation

The ratio of the amplitude of the signal at the output of one DAC to a sine wave on the reference input of another DAC. It is measured in decibels (dB).

Reference Temperature Coefficient

A measure of the change in the reference output voltage with a change in temperature. It is expressed in parts per million per degree Celsius (ppm/ $^{\circ}$ C).

Digital Crosstalk

A measure of the impulse injected into the analog output of one DAC from the digital inputs of another DAC but is measured when the DAC output is not updated. It is specified in nanovolt-seconds (nV-sec) and measured with a full-scale code change on the data bus, that is, from all 0s to all 1s, and vice versa.

Thermal Hysteresis

The change of reference output voltage after the device is cycled through temperatures from -40°C to $+85^{\circ}\text{C}$ and back to -40°C . This is a typical value from a sample of devices put through such a cycle.

THEORY OF OPERATION

The AD5762R is a dual, 16-bit, serial input, bipolar voltage output DAC that operates from supply voltages of $\pm 11.4\text{ V}$ to $\pm 16.5\text{ V}$ and has a buffered output voltage of up to $\pm 10.5263\text{ V}$. Data is written to the AD5762R in a 24-bit word format via a 3-wire serial interface. The AD5762R also offers an SDO pin that is available for daisy chaining or readback.

The AD5762R incorporates a power-on reset circuit that ensures that the DAC registers are loaded with 0x0000 on power-up. The AD5762R features a digital input/output port that can be programmed via the serial interface, an analog die temperature sensor, on-chip 10 ppm/ $^{\circ}\text{C}$ voltage reference, on-chip reference buffers, and per channel digital gain and offset registers.

DAC ARCHITECTURE

The DAC architecture of the AD5762R consists of a 16-bit current mode segmented R-2R DAC. The simplified circuit diagram for the DAC section is shown in Figure 39.

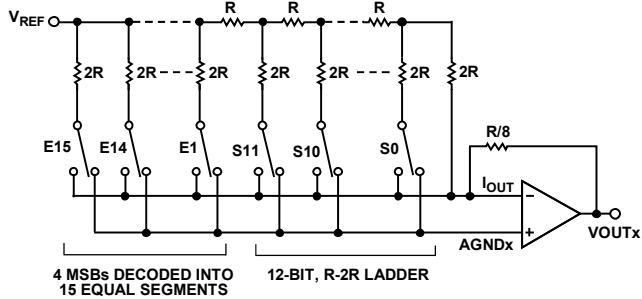

Figure 39. DAC Ladder Structure

The four MSBs of the 16-bit data-word are decoded to drive 15 switches, E1 to E15. Each of these switches connects one of the 15 matched resistors to either AGNDx or IOUT. The remaining 12 bits of the data-word drive Switch S0 to Switch S11 of the 12-bit R-2R ladder network.

REFERENCE BUFFERS

The AD5762R can operate with either an external or an internal reference. The reference inputs (REFA and REFB) have an input range up to 7 V. This input voltage is then used to provide a buffered positive and negative reference for the DAC cores. The positive reference is given by

$$+V_{REF} = 2 \times V_{REFIN}$$

The negative reference to the DAC cores is given by

$$-V_{REF} = -2 \times V_{REFIN}$$

These positive and negative reference voltages (along with the gain register values) define the output ranges of the DACs.

SERIAL INTERFACE

The AD5762R is controlled over a versatile 3-wire serial interface that operates at clock rates of up to 30 MHz and is compatible with SPI, QSPI™, MICROWIRE, and DSP standards.

Input Shift Register

The input shift register is 24 bits wide. Data is loaded into the device, MSB first, as a 24-bit word under the control of a serial clock input, SCLK. The input register consists of a read/write bit, a reserved bit that must be set to 0, three register select bits, three DAC address bits, and 16 data bits, as shown in Table 9. The timing diagram for this operation is shown in Figure 2.

Upon power-up, the DAC registers are loaded with zero code (0x0000), and the outputs are clamped to 0 V via a low impedance path. The outputs can be updated with the zero code value by asserting either LDAC or CLR. The corresponding output voltage depends on the state of the BIN/2sCOMP pin. If the BIN/2sCOMP pin is tied to DGND, the data coding is twos complement and the outputs update to 0 V. If the BIN/2sCOMP pin is tied to DVCC, the data coding is offset binary and the outputs update to negative full scale. To have the outputs power-up with zero code loaded to the outputs, the CLR pin should be held low during power-up.

Standalone Operation

The serial interface works with both a continuous and noncontinuous serial clock. A continuous SCLK source can be used only if SYNC is held low for the correct number of clock cycles. In gated clock mode, a burst clock containing the exact number of clock cycles must be used and SYNC must be taken high after the final clock to latch the data. The first falling edge of SYNC starts the write cycle. Exactly 24 falling clock edges must be applied to SCLK before SYNC is brought high again. If SYNC is brought high before the 24th falling SCLK edge, the data written is invalid. If more than 24 falling SCLK edges are applied before SYNC is brought high, the input data is also invalid. The input register addressed is updated on the rising edge of SYNC. For another serial transfer to take place, SYNC must be brought low again. After the end of the serial data transfer, data is automatically transferred from the input shift register to the addressed register.

When the data has been transferred into the chosen register of the addressed DAC, all DAC registers and outputs can be updated by taking LDAC low.

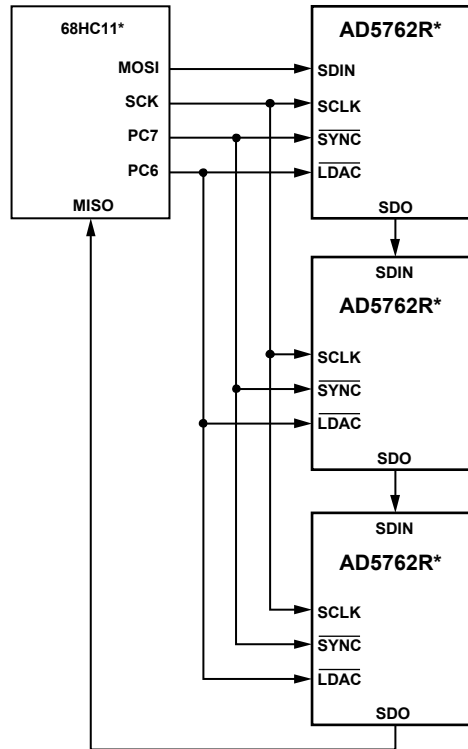

*ADDITIONAL PINS OMITTED FOR CLARITY.

Figure 40. Daisy-Chaining the AD5762R

Daisy-Chain Operation

For systems that contain several devices, the SDO pin can be used to daisy-chain several devices together. This daisy-chain mode can be useful in system diagnostics and in reducing the number of serial interface lines. The first falling edge of $\overline{\text{SYNC}}$ starts the write cycle. The SCLK is continuously applied to the input shift register when $\overline{\text{SYNC}}$ is low. If more than 24 clock pulses are applied, the data ripples out of the shift register and appears on the SDO line. This data is clocked out on the rising edge of SCLK and is valid on the falling edge. By connecting the SDO of the first device to the SDIN input of the next device in the chain, a multidevice interface is constructed. Each device in the system requires 24 clock pulses. Therefore, the total number of clock cycles must equal $24n$, where n is the total number of AD5762R devices in the chain. When the serial transfer to all devices is complete, $\overline{\text{SYNC}}$ is taken high. This latches the input data in each device in the daisy chain and prevents any further data from being clocked into the input shift register. The serial clock can be a continuous or a gated clock.

A continuous SCLK source can be used only if $\overline{\text{SYNC}}$ is held low for the correct number of clock cycles. In gated clock mode, a burst clock containing the exact number of clock cycles must be used, and $\overline{\text{SYNC}}$ must be taken high after the final clock to latch the data.

Readback Operation

Before a readback operation is initiated, the SDO pin must be enabled by writing to the function register and clearing the SDO disable bit; this bit is cleared by default. Readback mode is invoked by setting the R/W bit = 1 in the serial input register write. With R/W = 1, Bit A2 to Bit A0, in association with Bit REG2, Bit REG1, and Bit REG0, select the register to be read. The remaining data bits in the write sequence are don't care. During the next SPI write, the data appearing on the SDO output contains the data from the previously addressed register. For a read of a single register, the NOP command can be used in clocking out the data from the selected register on SDO. The readback diagram in Figure 4 shows the readback sequence. For example, to read back the fine gain register of Channel A on the AD5762R, implement the following sequence:

1. Write 0xA0XXXX to the input register. This write configures the AD5762R for read mode with the fine gain register of Channel A selected. Note that all of the data bits, DB15 to DB0, are don't care.
2. Follow with a second write: an NOP condition, 0x00XXXX. During this write, the data from the fine gain register is clocked out on the SDO line; that is, data clocked out contains the data from the fine gain register in Bit DB5 to Bit DB0.

SIMULTANEOUS UPDATING VIA $\overline{\text{LDAC}}$

Depending on the status of both $\overline{\text{SYNC}}$ and $\overline{\text{LDAC}}$, and after data has been transferred into the input register of the DACs, there are two ways to update the DAC registers and DAC outputs.

Individual DAC Updating

In this mode, $\overline{\text{LDAC}}$ is held low while data is being clocked into the input shift register. The addressed DAC output is updated on the rising edge of $\overline{\text{SYNC}}$.

Simultaneous Updating of All DACs

In this mode, $\overline{\text{LDAC}}$ is held high while data is being clocked into the input shift register. All DAC outputs are updated by taking $\overline{\text{LDAC}}$ low any time after $\overline{\text{SYNC}}$ has been taken high. The update then occurs on the falling edge of $\overline{\text{LDAC}}$.

See Figure 41 for a simplified block diagram of the DAC load circuitry.

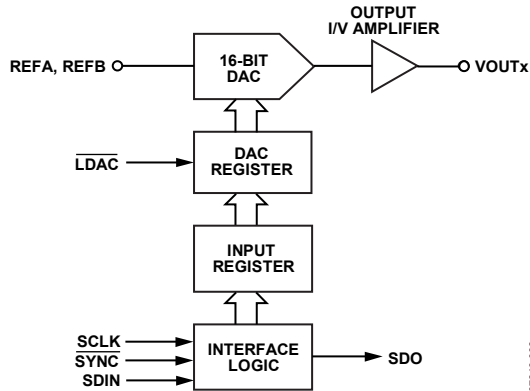

Figure 41. Simplified Serial Interface of Input Loading Circuitry for One DAC Channel

TRANSFER FUNCTION

Table 7 and Table 8 show the ideal input code to output voltage relationship for both offset binary data coding and twos complement data coding, respectively.

Table 7. Ideal Output Voltage to Input Code Relationship—Offset Binary Data Coding

Digital Input				Analog Output
MSB			LSB	V _{OUT}
1111	1111	1111	1111	+2 V _{REFIN} × (32,767/32,768)
1000	0000	0000	0001	+2 V _{REFIN} × (1/32,768)
1000	0000	0000	0000	0 V
0111	1111	1111	1111	-2 V _{REFIN} × (1/32,768)
0000	0000	0000	0000	-2 V _{REFIN} × (32,768/32,768)

Table 8. Ideal Output Voltage to Input Code Relationship—Twos Complement Data Coding

Digital Input				Analog Output
MSB			LSB	V _{OUT}
0111	1111	1111	1111	+2 V _{REFIN} × (32,767/32,768)
0000	0000	0000	0001	+2 V _{REFIN} × (1/32,768)
0000	0000	0000	0000	0 V
1111	1111	1111	1111	-2 V _{REFIN} × (1/32,768)
1000	0000	0000	0000	-2 V _{REFIN} × (32,768/32,768)

The output voltage expression for the AD5762R is given by

$$V_{OUT} = -2 \times V_{REFIN} + 4 \times V_{REFIN} \left(\frac{D}{65,536} \right)$$

where:

D is the decimal equivalent of the code loaded to the DAC.
 V_{REFIN} is the reference voltage applied at the REFA, REFB pins.

ASYNCHRONOUS CLEAR (CLR)

CLR is a negative edge triggered clear that allows the outputs to be cleared to either 0 V (twos complement coding) or negative full scale (offset binary coding). It is necessary to maintain CLR low for a minimum amount of time (see Figure 2) for the operation to complete. When the CLR signal is returned high, the output remains at the cleared value until a new value is programmed. If CLR is at 0 V at power-on, all DAC outputs are updated with the clear value. A clear can also be initiated through software by writing the command of 0x04XXXX to the AD5762R.

REGISTERS

Table 9. Input Shift Register Format

MSB								LSB
DB23	DB22	DB21	DB20	DB19	DB18	DB17	DB16	DB15 to DB0
R/W	0	REG2	REG1	REG0	A2	A1	A0	Data

Table 10. Input Shift Register Bit Function Descriptions

Register Bit	Descriptions			
R/W	Indicates a read from or a write to the addressed register			
REG2, REG1, REG0	Used in association with the address bits, determines if a read or write operation is to the data register, offset register, gain register, or function register			
	REG2	REG1	REG0	Function
	0	0	0	Function register
	0	1	0	Data register
	0	1	1	Coarse gain register
	1	0	0	Fine gain register
	1	0	1	Offset register
A2, A1, A0	Decodes the DAC channels			
	A2	A1	A0	Channel Address
	0	0	0	DAC A
	0	0	1	DAC B
	1	0	0	Both DACs
Data	Data bits			

FUNCTION REGISTER

The function register is addressed by setting the three REG bits to 000. The values written to the address bits and the data bits determine the function addressed. The functions available via the function register are outlined in Table 11 and Table 12.

Table 11. Function Register Options

REG2	REG1	REG0	A2	A1	A0	DB15 to DB6	DB5	DB4	DB3	DB2	DB1	DB0
0	0	0	0	0	0	NOP, data = don't care						
0	0	0	0	0	1	Don't care	Local ground offset adjust	D1 direction	D1 value	D0 direction	D0 value	SDO disable
0	0	0	1	0	0	Clear, data = don't care						
0	0	0	1	0	1	Load, data = don't care						

Table 12. Explanation of Function Register Options

Option	Description
NOP	No operation instruction used in readback operations.
Local Ground Offset Adjust	Set by the user to enable the local ground offset adjust function. Cleared by the user to disable the local ground offset adjust function (default). See the Design Features section for more information.
D0, D1 Direction	Set by the user to enable the D0 and D1 pins as outputs. Cleared by the user to enable the D0 and D1 pins as inputs (default). See the Design Features section for more information.
D0, D1 Value	Input/output port status bits. Logic values written to these locations determine the logic outputs on the D0 and D1 pins when configured as outputs. These bits indicate the status of the D0 and D1 pins when the input/output port is active as an input. When enabled as inputs, these bits are don't cares during a write operation.
SDO Disable	Set by the user to disable the SDO output. Cleared by the user to enable the SDO output (default).
Clear	Addressing this function resets the DAC outputs to 0V in twos complement mode and negative full scale in binary mode.
Load	Addressing this function updates the DAC registers and, consequently, the analog outputs.

DATA REGISTER

The data register is addressed by setting the three REG bits to 010. The DAC address bits select the DAC channel with which the data transfer takes place (see Table 10). The data bits are positioned in DB15 to DB0, as shown in Table 13.

Table 13. Programming the Data Register

REG2	REG1	REG0	A2	A1	A0	DB15 to DB0
0	1	0	DAC address			16-bit DAC data

COARSE GAIN REGISTER

The coarse gain register is addressed by setting the three REG bits to 011. The DAC address bits select the DAC channel with which the data transfer takes place (see Table 10). The coarse gain register is a 2-bit register that allows the user to select the output range of each DAC, as shown in Table 15.

Table 14. Programming the Coarse Gain Register

REG2	REG1	REG0	A2	A1	A0	DB15 to DB2	DB1	DB0
0	1	1	DAC address			Don't care	CG1	CG0

Table 15. Output Range Selection

Output Range	CG1	CG0
±10 V (Default)	0	0
±10.2564 V	0	1
±10.5263 V	1	0

FINE GAIN REGISTER

The fine gain register is addressed by setting the three REG bits to 100. The DAC address bits select the DAC channel with which the data transfer takes place (see Table 10). The [AD5762R](#) fine gain register is a 6-bit register that allows the user to adjust the gain of each DAC channel by –32 LSBs to +31 LSBs in 1 LSB steps, as shown in Table 16 and Table 17. The adjustment is made to both the positive full-scale points and the negative full-scale points simultaneously, with each point adjusted by one-half of one step. The fine gain register coding is twos complement.

Table 16. Programming the Fine Gain Register

REG2	REG1	REG0	A2	A1	A0	DB15 to DB6	DB5	DB4	DB3	DB2	DB1	DB0
1	0	0	DAC address			Don't care	FG5	FG4	FG3	FG2	FG1	FG0

Table 17. Fine Gain Register Options

Gain Adjustment	FG5	FG4	FG3	FG2	FG1	FG0
+31 LSBs	0	1	1	1	1	1
+30 LSBs	0	1	1	1	1	0
No Adjustment (Default)	0	0	0	0	0	0
–31 LSBs	1	0	0	0	0	1
–32 LSBs	1	0	0	0	0	0

OFFSET REGISTER

The offset register is addressed by setting the three REG bits to 101. The DAC address bits select the DAC channel with which the data transfer is to take place (see Table 10). The AD5762R offset register is an 8-bit register and allows the user to adjust the offset of each channel by -16 LSBs to $+15.875$ LSBs in steps of $\frac{1}{8}$ LSB, as shown in Table 18 and Table 19. The offset register coding is twos complement.

Table 18. Programming the Offset Register

REG2	REG1	REG0	A2	A1	A0	DB15:DB8	DB7	DB6	DB5	DB4	DB3	DB2	DB1	DB0
1	0	1	DAC address			Don't care	OF7	OF6	OF5	OF4	OF3	OF2	OF1	OF0

Table 19. Offset Register Options

Offset Adjustment	OF7	OF6	OF5	OF4	OF3	OF2	OF1	OF0
+15.875 LSBs	0	1	1	1	1	1	1	1
+15.75 LSBs	0	1	1	1	1	1	1	0
No Adjustment (Default)	0	0	0	0	0	0	0	0
-15.875 LSBs	1	0	0	0	0	0	0	1
-16 LSBs	1	0	0	0	0	0	0	0

OFFSET AND GAIN ADJUSTMENT WORKED EXAMPLE

Using the information provided in the previous section, the following worked example demonstrates how the AD5762R functions can be used to eliminate both offset and gain errors. As the AD5762R is factory calibrated, offset and gain errors should be negligible. However, errors can be introduced by the system that the AD5762R is operating within, for example, a voltage reference value that is not equal to $+5$ V introduces a gain error. An output range of ± 10 V and twos complement data coding is assumed.

Removing Offset Error

The AD5762R can eliminate an offset error in the range of -4.88 mV to $+4.84$ mV with a step size of $\frac{1}{8}$ of a 16-bit LSB.

1. Calculate the step size of the offset adjustment

$$\text{Offset Adjust Step Size} = \frac{20}{2^{16} \times 8} = 38.14 \mu\text{V}$$

2. Measure the offset error by programming 0x0000 to the data register and measuring the resulting output voltage. For this example, the measured value is $+614 \mu\text{V}$.
3. Determine the number of offset adjustment steps this value represents, using the following equation:

$$\text{Number Steps} = \frac{\text{Measured Offset Value}}{\text{Offset Step Size}} = \frac{614 \mu\text{V}}{38.14 \mu\text{V}} = 16 \text{ Steps}$$

The offset error measured is positive; therefore, a negative adjustment of 16 steps is required. The offset register is 8 bits wide, and the coding is twos complement.

The required offset register value can be calculated as follows:

1. Convert the adjustment value to binary: 00010000.
2. Convert this value to a negative twos complement number by inverting all bits and adding 1: 11110000.
3. Program 11110000 to the offset register.

Note that this twos complement conversion is not necessary in the case of a positive offset adjustment. The value to be programmed to the offset register is simply the binary representation of the adjustment value.

Removing Gain Error

The AD5762R can eliminate a gain error at a negative full-scale output in the range of -9.77 mV to $+9.46$ mV with a step size of $\frac{1}{2}$ of a 16-bit LSB.

1. Calculate the step size of the gain adjustment using the following equation:

$$\text{Gain Adjust Step Size} = \frac{20}{2^{16} \times 2} = 152.59 \mu\text{V}$$

2. Measure the gain error by programming 0x8000 to the data register and measuring the resulting output voltage. The gain error is the difference between this value and -10 V. For this example, the gain error is -1.2 mV.
3. Determine how many gain adjustment steps this value represents by using the following equation:

$$\text{Number of Steps} = \frac{\text{Measured Gain Value}}{\text{Gain Step Size}} = \frac{1.2 \text{ mV}}{152.59 \mu\text{V}} = 8 \text{ Steps}$$

The gain error measured is negative (in terms of magnitude); therefore, a positive adjustment of eight steps is required. The gain register is 6 bits wide, and the coding is twos complement. The required gain register value can be determined as follows:

1. Convert the adjustment value to binary: 001000.
2. 001000 is the value to be programmed to the gain register.

DESIGN FEATURES

ANALOG OUTPUT CONTROL

In many industrial process control applications, it is vital that the output voltage be controlled during power-up and during brownout conditions. When the supply voltages are changing, the VOUTx pins are clamped to 0 V via a low impedance path. To prevent the output amp from being shorted to 0 V during this time, Transmission Gate G1 is also opened (see Figure 42).

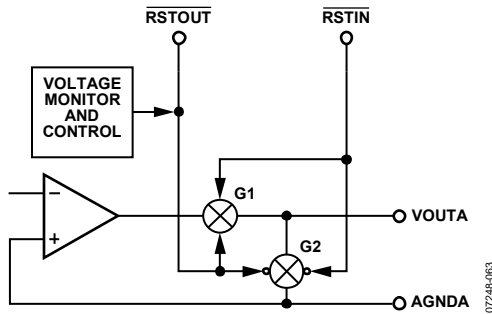

Figure 42. Analog Output Control Circuitry

These conditions are maintained until the power supplies stabilize and a valid word is written to the DAC register. G2 then opens, and G1 closes. Both transmission gates are also externally controllable via the reset in ($\overline{\text{RSTIN}}$) control input. For example, if $\overline{\text{RSTIN}}$ is driven from a battery supervisor chip, the $\overline{\text{RSTIN}}$ input is driven low to open G1 and close G2 on power-off or during a brownout. Conversely, the on-chip voltage detector output ($\overline{\text{RSTOUT}}$) is also available to the user to control other parts of the system. The basic transmission gate functionality is shown in Figure 42.

DIGITAL OFFSET AND GAIN CONTROL

The AD5762R incorporates a digital offset adjust function with a ± 16 LSB adjust range and 0.125 LSB resolution. The gain register allows the user to adjust the AD5762R full-scale output range. The full-scale output can be programmed to achieve full-scale ranges of ± 10 V, ± 10.25 V, and ± 10.5 V. A fine gain trim is also available.

PROGRAMMABLE SHORT-CIRCUIT PROTECTION

The short-circuit current (I_{SC}) of the output amplifiers can be programmed by inserting an external resistor between the ISCC pin and PGND. The programmable range for the current is 500 μA to 10 mA, corresponding to a resistor range of 120 k Ω to 6 k Ω . The resistor value is calculated as follows:

$$R \approx \frac{60}{I_{SC}}$$

If the ISCC pin is left unconnected, the short-circuit current limit defaults to 5 mA. It should be noted that limiting the short-circuit current to a small value can affect the slew rate of the output when driving into a capacitive load. Therefore, the value of the short-circuit current that is programmed should take into account the size of the capacitive load being driven.

DIGITAL INPUT/OUTPUT PORT

The AD5762R contains a 2-bit digital input/output port (D1 and D0). These bits can be configured independently as inputs or outputs and can be driven or have their values read back via the serial interface. The input/output port signals are referenced to DV_{CC} and DGND . When configured as outputs, they can be used as control signals to multiplexers or can be used to control calibration circuitry elsewhere in the system. When configured as inputs, the logic signals from limit switches, for example, can be applied to D0 and D1 and can be read back using the digital interface.

DIE TEMPERATURE SENSOR

The on-chip die temperature sensor provides a voltage output that is linearly proportional to the Celsius temperature scale. Its nominal output voltage is 1.47 V at 25°C die temperature, varying at 5 mV/°C, giving a typical output range of 1.175 V to 1.9 V over the full temperature range. Its low output impedance and linear output simplify interfacing to temperature control circuitry and analog-to-digital converters (ADCs). The temperature sensor is provided as more of a convenience than as a precise feature; it is intended for indicating a die temperature change for recalibration purposes.

LOCAL GROUND OFFSET ADJUST

The AD5762R incorporates a local ground offset adjust feature that, when enabled in the function register, adjusts the DAC outputs for voltage differences between the individual DAC ground pins and the REFGND pin, ensuring that the DAC output voltages are always referenced to the local DAC ground pin. For example, if the AGNDA pin is at +5 mV with respect to the REFGND pin and VOUTA is measured with respect to AGNDA, a -5 mV error results, enabling the local ground offset adjust feature to adjust VOUTA by +5 mV, thereby eliminating the error.

APPLICATIONS INFORMATION

TYPICAL OPERATING CIRCUIT

Figure 43 shows the typical operating circuit for the [AD5762R](#). The only external components needed for this precision 16-bit DAC are decoupling capacitors on the supply pins and reference inputs, and an optional short-circuit current setting resistor. Because the [AD5762R](#) incorporates a voltage reference and reference buffers, it eliminates the need for an external bipolar reference and associated buffers, resulting in an overall savings in both cost and board space.

In Figure 43, AV_{DD} and AV_{SS} are both connected to ± 15 V, but AV_{DD} and AV_{SS} can operate with supplies from ± 11.4 V to ± 16.5 V. In Figure 43, $AGNDA$ and $AGNDB$ are connected to $REFGND$.

Precision Voltage Reference Selection

To achieve the optimum performance from the [AD5762R](#) over its full operating temperature range, an external voltage reference must be used. Care must be taken in the selection of a precision voltage reference. The voltage applied to the reference input is used to provide a buffered positive and negative reference for the DAC cores. Therefore, any error in the voltage reference is reflected in the outputs of the device.

There are four possible sources of error to consider when choosing a voltage reference for high accuracy applications: initial accuracy, temperature coefficient of the output voltage, long-term drift, and output voltage noise.

Table 20. Some Precision References Recommended for Use with the [AD5762R](#)

Device No.	Initial Accuracy (mV Maximum)	Long-Term Drift (ppm Typical)	Temperature Drift (ppm/°C Maximum)	0.1 Hz to 10 Hz Noise (μ V p-p Typical)
ADR435	± 6	30	3	3.5
ADR425	± 6	50	3	3.4
ADRO2	± 5	50	3	10
ADR395	± 6	50	25	5
AD586	± 2.5	15	10	4

Initial accuracy error on the output voltage of an external reference can lead to a full-scale error in the DAC. Therefore, to minimize these errors, a reference with low initial accuracy error specification is preferred. Choosing a reference with an output trim adjustment, such as the [ADR425](#), allows a system designer to trim system errors out by setting the reference voltage to a voltage other than the nominal. The trim adjustment can also be used at temperature to trim out any error.

Long-term drift is a measure of how much the reference output voltage drifts over time. A reference with a tight long-term drift specification ensures that the overall solution remains relatively stable over its entire lifetime.

The temperature coefficient of a reference output voltage affects INL, DNL, and TUE. A reference with a tight temperature coefficient specification should be chosen to reduce the dependence of the DAC output voltage on ambient conditions.

In high accuracy applications, which have a relatively low noise budget, reference output voltage noise must be considered. It is important to choose a reference with as low an output noise voltage as practical for the system resolution that is required. Precision voltage references such as the [ADR435](#) (XFET® design) produce low output noise in the 0.1 Hz to 10 Hz region. However, as the circuit bandwidth increases, filtering the output of the reference may be required to minimize the output noise.

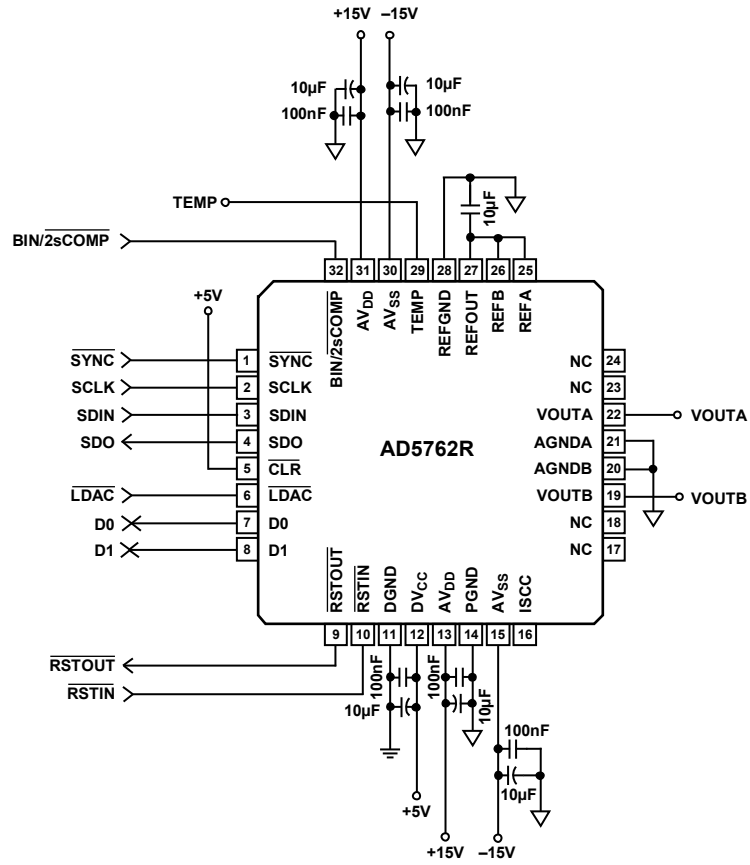

Figure 43. Typical Operating Circuit

07248-064

LAYOUT GUIDELINES

In any circuit where accuracy is important, careful consideration of the power supply and ground return layout helps to ensure the rated performance. Design the printed circuit board (PCB) on which the AD5762R is mounted such that the analog and digital sections are separated and confined to certain areas of the board. If the AD5762R is in a system where multiple devices require an AGNDx-to-DGND connection, establish the connection at one point only. Establish the star ground point as close as possible to the device. The AD5762R should have ample supply bypassing of 10 μF in parallel with 0.1 μF on each supply located as close to the package as possible, ideally right up against the device. The 10 μF capacitors are of the tantalum bead type. The 0.1 μF capacitor should have low effective series resistance (ESR) and low effective series inductance (ESI), such as the common ceramic types that provide a low impedance path to ground at high frequencies to handle transient currents due to internal logic switching.

The power supply lines of the AD5762R should use as large a trace as possible to provide low impedance paths and reduce the effects of glitches on the power supply line. Shield fast-switching signals, such as clocks, with digital ground to avoid radiating noise to other parts of the board; they should never be run near the reference inputs. A ground line routed between the SDIN and SCLK lines helps reduce cross talk between them. (A ground line is not required on a multilayer board because it has a separate ground plane; however, it is helpful to separate the lines.) It is essential to minimize noise on the reference inputs because it couples through to the DAC output. Avoid crossover of digital and analog signals. Run traces on opposite sides of the board at right angles

to each other to reduce the effects of feedthrough on the board. A microstrip technique is recommended, but not always possible, with a double-sided board. In this technique, the component side of the board is dedicated to the ground plane, and signal traces are placed on the solder side.

GALVANICALLY ISOLATED INTERFACE

In many process control applications, it is necessary to provide an isolation barrier between the controller and the unit being controlled to protect and isolate the controlling circuitry from any hazardous common-mode voltages that may occur. Isocouplers provide voltage isolation in excess of 2.5 kV. The serial loading structure of the AD5762R makes it ideal for isolated interfaces because the number of interface lines is kept to a minimum. Figure 44 shows a 4-channel isolated interface to the AD5762R using an ADuM1400 iCoupler® product. For more information on iCoupler products, go to www.analog.com.

MICROPROCESSOR INTERFACING

Microprocessor interfacing to the AD5762R is accomplished using a serial bus that uses standard protocol that is compatible with microcontrollers and DSP processors. The communication channel is a 3-wire (minimum) interface consisting of a clock signal, a data signal, and a synchronization signal. The AD5762R requires a 24-bit data-word with data valid on the falling edge of SCLK.

For all the interfaces, a DAC output update can be performed automatically when all the data is clocked in, or it can be done under the control of $\overline{\text{LDAC}}$. The contents of the DAC register can be read using the readback function.

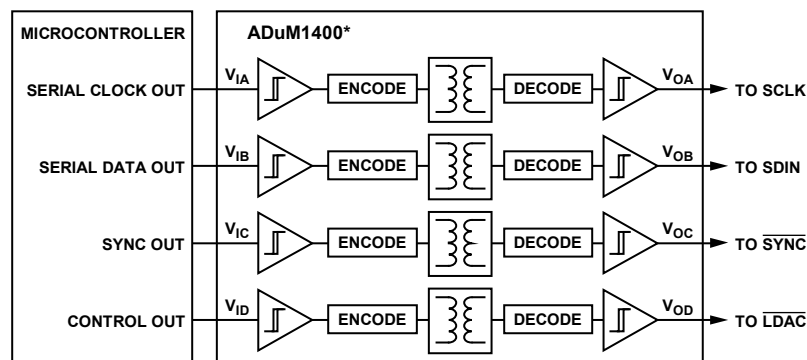

*ADDITIONAL PINS OMITTED FOR CLARITY.

Figure 44. Isolated Interface

07248-065

EVALUATION BOARD

The performance of the [AD5762R](#) can be evaluated using the [AD5764R](#) evaluation board.

The evaluation board aids designers in evaluating the high performance of the device with a minimum of effort. All that is required with the evaluation board is a power supply and a PC. The [AD5764R](#) evaluation kit includes a populated, tested

[AD5764R](#) PCB. The evaluation board interfaces to the USB interface of the PC. Software is available with the evaluation board that allows the user to easily program the [AD5764R](#). The software runs on any PC that has Microsoft Windows® 2000/XP installed.

An application note is available that gives full details on operating the evaluation board.

OUTLINE DIMENSIONS

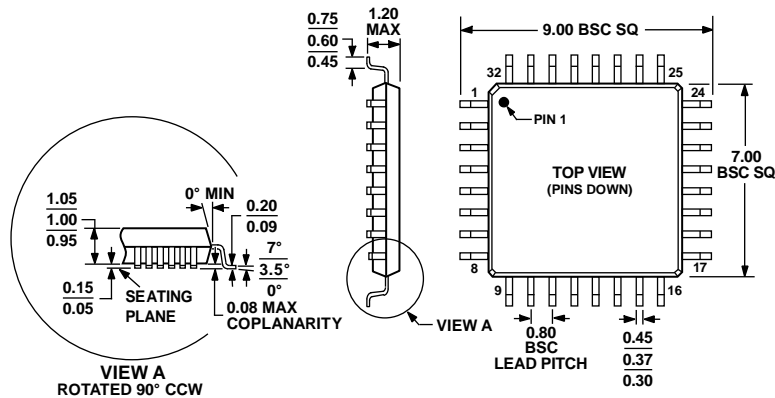

COMPLIANT TO JEDEC STANDARDS MS-026-ABA

Figure 45. 32-Lead Thin Plastic Dual Flat Package [TQFP] (SU-32-2)

Dimensions shown in millimeters

ORDERING GUIDE

Model ¹	Function	INL	Temperature Range	Internal Reference	Package Description	Package Option
AD5762RCSUZ	Dual 16-Bit DAC	±1 LSB Max	-40°C to +85°C	+5 V	32-Lead TQFP	SU-32-2
AD5762RCSUZ-REEL7	Dual 16-Bit DAC	±1 LSB Max	-40°C to +85°C	+5 V	32-Lead TQFP	SU-32-2

¹ Z = RoHS Compliant Part.

Looking for pricing, stock, or lifecycle information?

Click below to explore more details on WIN SOURCE:

 [View AD5762RCSUZ-REEL7 on WIN SOURCE](#)

 [Analog Devices Inc. Information](#)

Optimize Your Supply Chain with WIN SOURCE Solutions

-  Global Sourcing Solution
-  Obsolete Management
-  Cost Control Management
-  Shortage Management
-  Alternative Solution
-  Excess Inventory Management