



**THE DATASHEET OF
LTC1456CN8#PBF**



12-Bit Rail-to-Rail Micropower DAC with Clear Input

FEATURES

- SO-8 Package
- 12-Bit Resolution
- Buffered True Rail-to-Rail Voltage Output
- Asynchronous Clear Input
- Built-In Reference
- Schmitt Trigger On Clock Input Allows Direct Optocoupler Interface
- Power-On Reset Clears DAC to 0V
- 3-Wire Cascadable Serial Interface
- **Maximum DNL Error: 0.5LSB**
- Low Cost

APPLICATIONS

- Digital Calibration
- Industrial Process Control
- Automatic Test Equipment
- Cellular Telephones

DESCRIPTION

The LTC[®]1456 is a complete single supply, rail-to-rail voltage output, 12-bit digital-to-analog converter (DAC) in an SO-8 package. It includes a rail-to-rail output buffer amplifier and an easy-to-use 3-wire cascadable serial interface. The LTC1456 includes a CLR pin that asynchronously clears the DAC to zero scale.

The LTC1456 has an internal 2.048V reference and a full-scale output of 4.095V. It operates on a 4.5V to 5.5V supply, dissipating 2.2mW.

The low power supply current and the space saving SO-8 package make the LTC1456 ideal for battery-powered applications.

LT, LTC and LT are registered trademarks of Linear Technology Corporation.

TYPICAL APPLICATION

Functional Block Diagram: 12-Bit Rail-to-Rail DAC with Clear Input

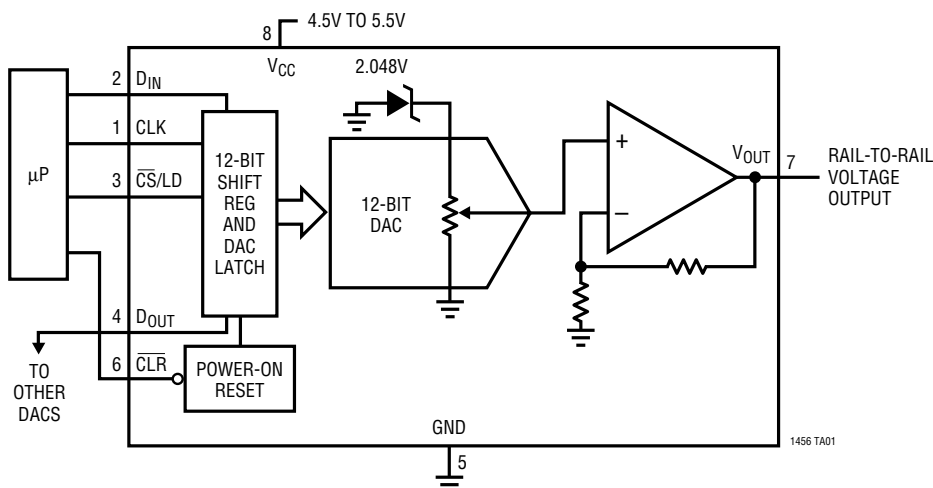

Differential Nonlinearity vs Input Code

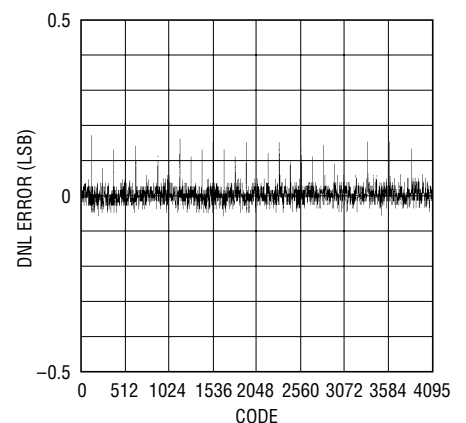

1456 TA02

ABSOLUTE MAXIMUM RATINGS

V_{CC} to GND	-0.5V to 7.5V
Logic Inputs to GND	-0.5V to 7.5V
V_{OUT}	-0.5V to $V_{CC} + 0.5V$
Maximum Junction Temperature	-65°C to 125°C
Operating Temperature Range	
LTC1456C	0°C to 70°C
LTC1456I	-40°C to 85°C
Storage Temperature Range	-65°C to 150°C
Lead Temperature (Soldering, 10 sec)	300°C

PACKAGE/ORDER INFORMATION

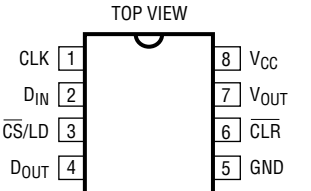
 <p>N8 PACKAGE 8-LEAD PDIP</p> <p>S8 PACKAGE 8-LEAD PLASTIC SO</p> <p>$T_{JMAX} = 125^{\circ}C, \theta_{JA} = 100^{\circ}C/W$ (N8) $T_{JMAX} = 125^{\circ}C, \theta_{JA} = 150^{\circ}C/W$ (S8)</p>	ORDER PART NUMBER
	LTC1456CN8 LTC1456IN8 LTC1456CS8 LTC1456IS8
	S8 PART MARKING
	1456 1456I

Consult factory for Military grade parts.

ELECTRICAL CHARACTERISTICS

$V_{CC} = 4.5V$ to $5.5V$, V_{OUT} unloaded, $T_A = T_{MIN}$ to T_{MAX} , unless otherwise noted.

SYMBOL	PARAMETER	CONDITIONS	MIN	TYP	MAX	UNITS	
DAC							
	Resolution		●	12		Bits	
DNL	Differential Nonlinearity	Guaranteed Monotonic (Note 1)	●		±0.5	LSB	
INL	Integral Nonlinearity	$T_A = 25^{\circ}C$ (Note 1)	●		±3.5	LSB	
			●		±4	LSB	
V_{OS}	Offset Error	$T_A = 25^{\circ}C$	●		±12	mV	
			●		±18	mV	
V_{OSTC}	Offset Error Temperature Coefficient			±15		$\mu V/^{\circ}C$	
V_{FS}	Full-Scale Voltage	$T_A = 25^{\circ}C$	●	4.065	4.095	4.125	V
			●	4.045	4.095	4.145	V
V_{FSTC}	Full-Scale Voltage Temperature Coefficient			±24		ppm/ $^{\circ}C$	
Power Supply							
V_{CC}	Positive Supply Voltage	For Specified Performance	●	4.5	5.5	V	
I_{CC}	Supply Current	(Note 4)	●	430	650	μA	
Op Amp DC Performance							
	Short-Circuit Current Low	V_{OUT} Shorted to GND	●		120	mA	
	Short-Circuit Current High	V_{OUT} Shorted to V_{CC}	●		120	mA	
	Output Impedance to GND	Input Code = 0	●	40	120	Ω	
AC Performance							
	Voltage Output Slew Rate	(Note 2)	●	0.4	1.0	V/ μs	
	Voltage Output Settling Time	(Notes 2, 3) to ±0.5LSB		14		μs	
	Digital Feedthrough			0.3		nV•s	

ELECTRICAL CHARACTERISTICS

$V_{CC} = 4.5V$ to $5.5V$, V_{OUT} unloaded, $T_A = T_{MIN}$ to T_{MAX} , unless otherwise noted.

SYMBOL	PARAMETER	CONDITIONS	MIN	TYP	MAX	UNITS
Digital I/O						
V_{IH}	Digital Input High Voltage		●	2.4		V
V_{IL}	Digital Input Low Voltage		●		0.8	V
V_{OH}	Digital Output High Voltage	$I_{OUT} = -1mA$, D_{OUT} Only	●	$V_{CC} - 1.0$		V
V_{OL}	Digital Output Low Voltage	$I_{OUT} = 1mA$, D_{OUT} Only	●		0.4	V
I_{LEAK}	Digital Input Leakage	$V_{CC} = 5V$, $V_{IN} = GND$ to V_{CC}	●		± 10	μA
C_{IN}	Digital Input Capacitance	Guaranteed by Design. Not Subject to Test.	●		10	pF
Switching						
t_1	D_{IN} Valid to CLK Setup		●	40		ns
t_2	D_{IN} Valid to CLK Hold		●	0		ns
t_3	CLK High Time		●	40		ns
t_4	CLK Low Time		●	40		ns
t_5	\overline{CS}/LD Pulse Width		●	50		ns
t_6	LSB CLK to \overline{CS}/LD		●	40		ns
t_7	\overline{CS}/LD Low to CLK		●	20		ns
t_8	D_{OUT} Output Delay	$C_{LOAD} = 15pF$, $V_{CC} = 5V$	●		150	ns
t_9	CLK Low to \overline{CS}/LD Low		●	20		ns
t_{10}	\overline{CLR} Pulse Width		●	65		ns

The ● denotes specifications which apply over the full operating temperature range.

Note 1: Nonlinearity is defined from the first code that is greater than or equal to the maximum offset specification to code 4095 (full scale).

Note 2: Load is $5k\Omega$ in parallel with $100pF$.

Note 3: DAC switched between all 1s and the code corresponding to V_{OS} for the part.

Note 4: Digital inputs at $0V$ or V_{CC} .

TYPICAL PERFORMANCE CHARACTERISTICS

Differential Nonlinearity (DNL)

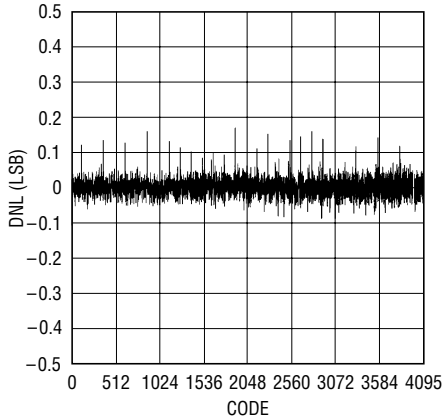

1456 G01

Integral Nonlinearity (INL)

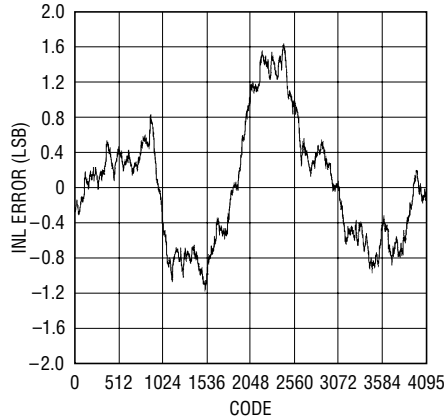

1456 G02

Minimum Supply Headroom for Full Output Swing vs Load Current

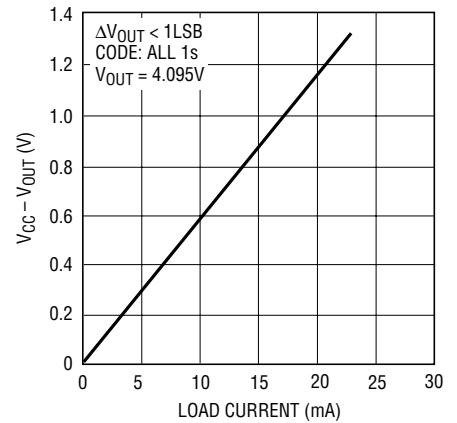

1456 G03

Minimum Output Voltage vs Output Sink Current

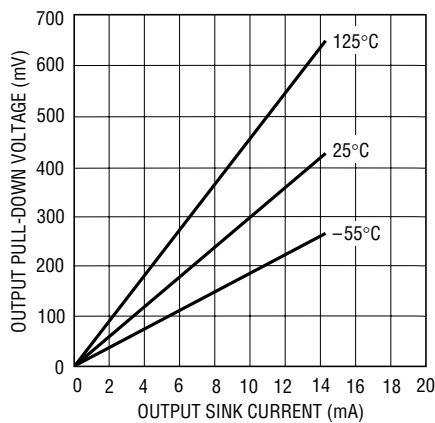

1456 G04

Supply Current vs Logic Input Voltage

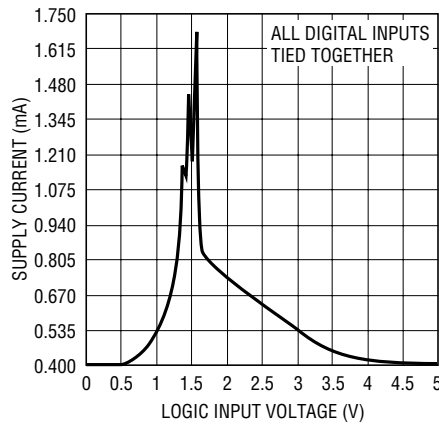

1456 G05

Output Swing vs Load Resistance

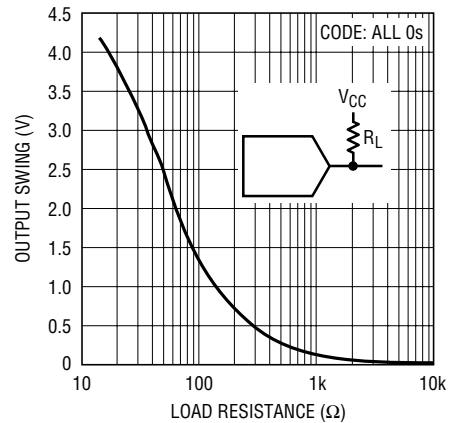

1456 G06

Output Swing vs Load Resistance

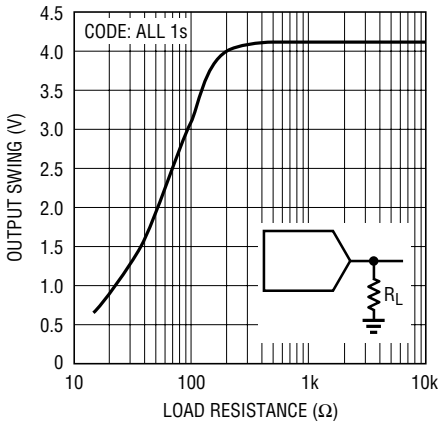

1456 G07

Offset Voltage vs Temperature

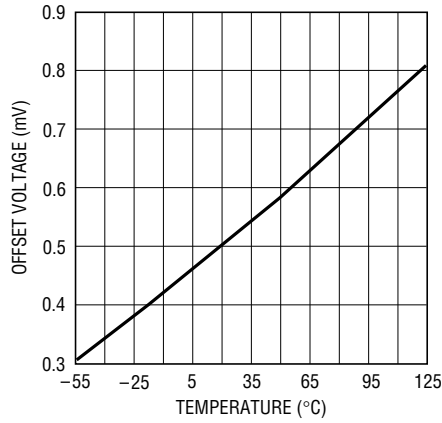

1456 G08

Supply Current vs Temperature

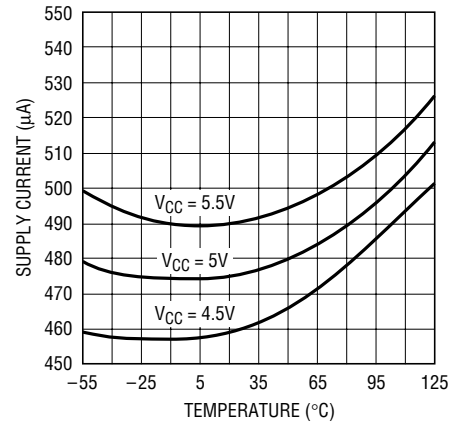

1456 G09

PIN FUNCTIONS

CLK (Pin 1): The Serial Interface Clock. Internal Schmitt trigger on this input allows direct optocoupler interface.

D_{IN} (Pin 2): The Serial Interface Data. Data on the D_{IN} pin is latched into the shift register on the rising edge of the serial clock.

$\overline{\text{CS/LD}}$ (Pin 3): The Serial Interface Enable and Load Control. When $\overline{\text{CS/LD}}$ is low the CLK signal is enabled, so the data can be clocked in. When $\overline{\text{CS/LD}}$ is pulled high, data is loaded from the shift register into the DAC register, updating the DAC output. When CS/LD is high the CLK is disabled internally.

D_{OUT} (Pin 4): The Output of the Shift Register Which Becomes Valid on the Rising Edge of the Serial Clock.

GND (Pin 5): Ground.

$\overline{\text{CLR}}$ (Pin 6): The Clear Input. When pulled low, this pin asynchronously clears the internal shift and DAC registers to zero scale. Should be tied high for normal operation.

V_{OUT} (Pin 7): The Buffered DAC Output.

V_{CC} (Pin 8): The Positive Supply Input. $4.5\text{V} \leq V_{\text{CC}} \leq 5.5\text{V}$. Requires a bypass capacitor to ground.

BLOCK DIAGRAM

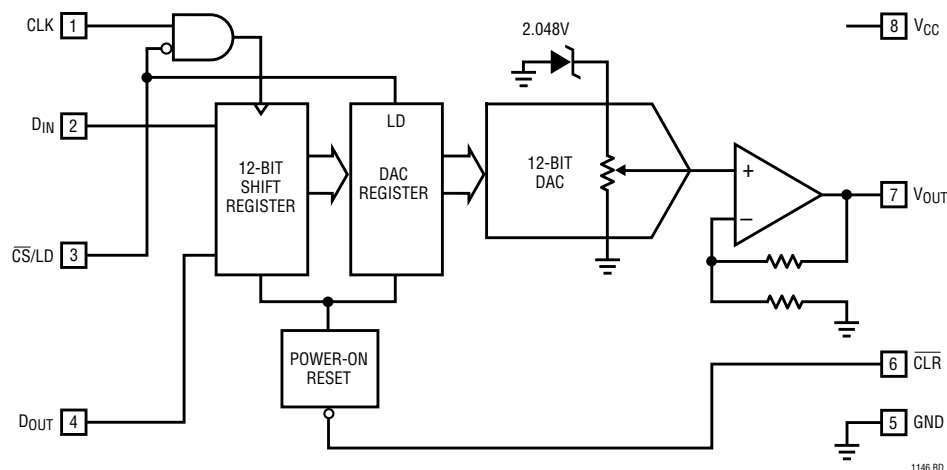

TIMING DIAGRAM

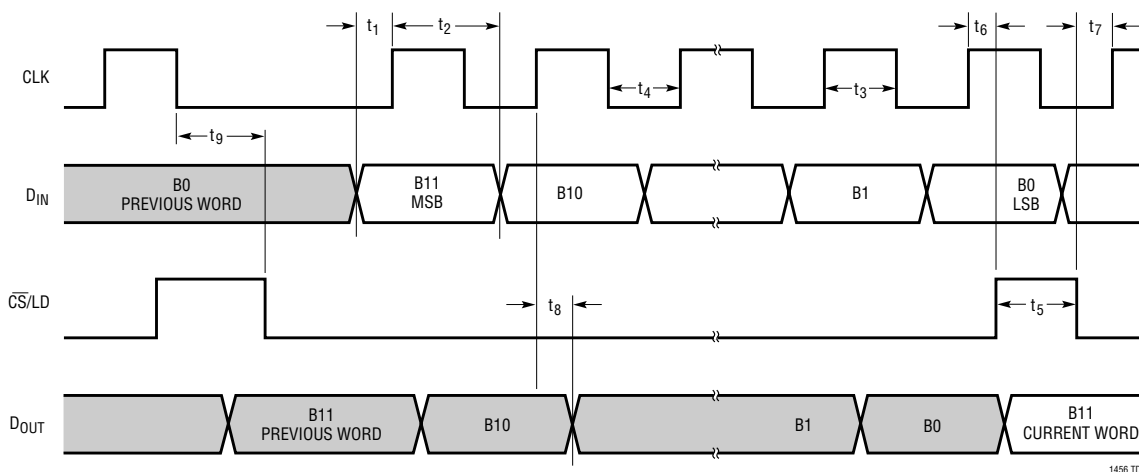

DEFINITIONS

Resolution (n): Resolution is defined as the number of digital input bits, n. It defines the number of DAC output states (2^n) that divide the full-scale range. The resolution does not imply linearity.

Full-Scale Voltage (V_{FS}): This is the output of the DAC when all bits are set to 1.

Voltage Offset Error (V_{OS}): The theoretical voltage at the output when the DAC is loaded with all zeros. The output amplifier can have a true negative offset, but because the part is operated from a single supply, the output cannot go below zero. If the offset is negative, the output will remain near 0V resulting in the transfer curve shown in Figure 1.

The offset of the part is measured at the code that corresponds to the maximum offset specification:

$$V_{OS} = V_{OUT} - [(Code \cdot V_{FS}) / (2^n - 1)]$$

Least Significant Bit (LSB): One LSB is the ideal voltage difference between two successive codes.

$$LSB = (V_{FS} - V_{OS}) / (2^n - 1) = (V_{FS} - V_{OS}) / 4095$$

$$LSB = 4.095 / 4095 = 1\text{mV}$$

Integral Nonlinearity (INL): End-point INL is the maximum deviation from a straight line passing through the end-points of the DAC transfer curve. Because the part operates from a single supply and the output cannot go below zero, the linearity is measured between full scale and the code corresponding to the maximum offset specification. The INL error at a given input code is calculated as follows:

$$INL = [V_{OUT} - V_{OS} - (V_{FS} - V_{OS})(code/4095)] / LSB$$

V_{OUT} = The output voltage of the DAC measured at the given input code

Differential Nonlinearity (DNL): DNL is the difference between the measured change and the ideal 1LSB change between any two adjacent codes. The DNL error between any two codes is calculated as follows:

$$DNL = (\Delta V_{OUT} - LSB) / LSB$$

ΔV_{OUT} = The measured voltage difference between two adjacent codes

Digital Feedthrough: The glitch that appears at the analog output caused by AC coupling from the digital inputs when they change state. The area of the glitch is specified in (nV)(sec).

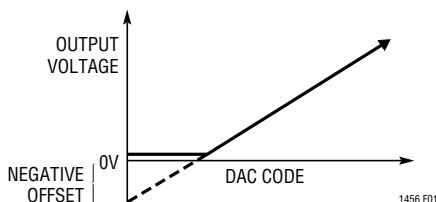

Figure 1. Effect of Negative Offset

OPERATION

Serial Interface

The data on the D_{IN} input is loaded into the shift register on the rising edge of the clock. The MSB is loaded first. The DAC register loads the data from the shift register when $\overline{CS/LD}$ is pulled high. The CLK is disabled internally when $\overline{CS/LD}$ is high. Note: CLK must be low before $\overline{CS/LD}$ is pulled low to avoid an extra internal clock pulse.

When \overline{CLR} is pulled low it asynchronously resets the shift and DAC registers to all zeros.

The buffered output of the 12-bit shift register is available on the D_{OUT} pin which swings from GND to V_{CC} . Multiple LTC1456s may be daisy-chained together by connecting the D_{OUT} pin to the D_{IN} pin of the next chip, while the CLK

and $\overline{CS/LD}$ signals remain common to all chips in the daisy chain. The serial data is clocked to all of the chips, then the $\overline{CS/LD}$ signal is pulled high to update all of them simultaneously.

Voltage Output

The LTC1456's rail-to-rail buffered output can source or sink 5mA over the entire operating temperature range while pulling to within 300mV of the positive supply voltage or ground. The output swings to within a few millivolts of either supply rail when unloaded and has an equivalent output resistance of 40 Ω when driving a load to the rails. The output can drive 1000pF without going into oscillation.

TYPICAL APPLICATION

The circuit below shows a digitally programmable current source from an external voltage source using an external op amp, an LT[®]1077 and an NPN transistor (2N3440). Any digital word from 0 to 4095 is loaded into the LTC1456 and its output correspondingly swings from 0V to 4.095V. In the configuration shown, this voltage will be forced across the resistor R_A . If R_A is chosen to be 410 Ω the output current will range from 0mA at zero scale to 10mA at full scale. The minimum voltage for V_S is determined by the load resistor R_L and Q1's V_{CESAT} voltage. With a load resistor of 50 Ω , the voltage source can be as low as 5V.

12-Bit 5V Single Supply Voltage Output DAC

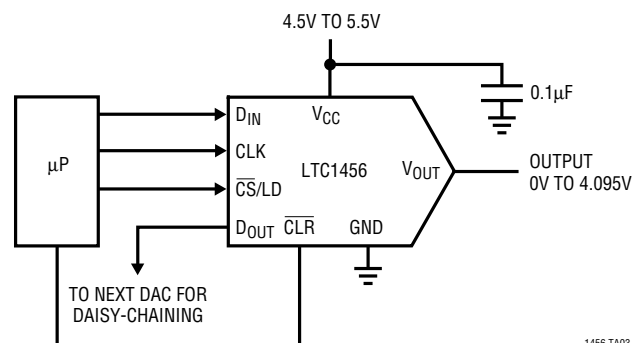

1456 TA03

Digitally Programmable Current Source

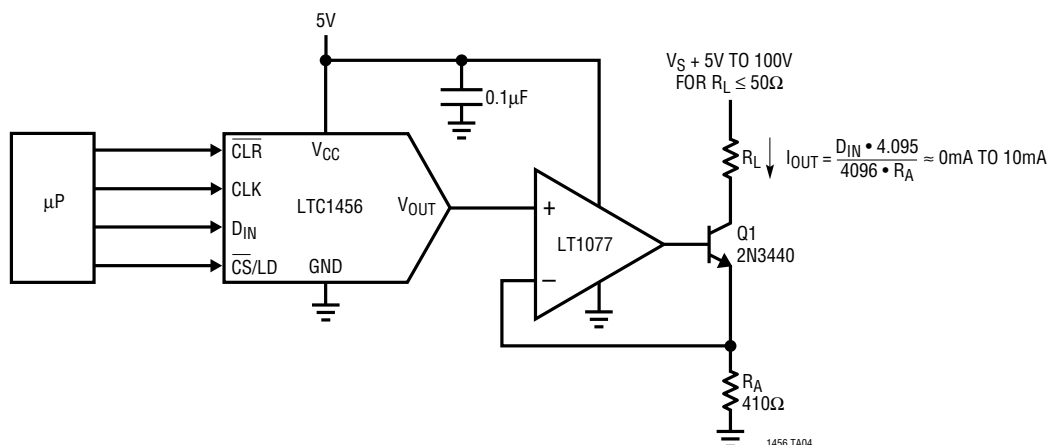

1456 TA04

PACKAGE DESCRIPTION Dimensions in inches (millimeters) unless otherwise noted.

N8 Package
8-Lead PDIP (Narrow 0.300)
 (LTC DWG # 05-08-1510)

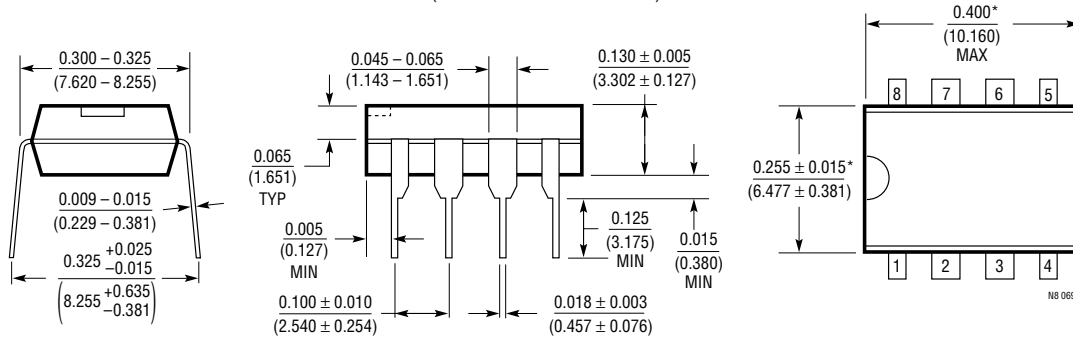

*THESE DIMENSIONS DO NOT INCLUDE MOLD FLASH OR PROTRUSIONS.
 MOLD FLASH OR PROTRUSIONS SHALL NOT EXCEED 0.010 INCH (0.254mm)

S8 Package
8-Lead Plastic Small Outline (Narrow 0.150)
 (LTC DWG # 05-08-1610)

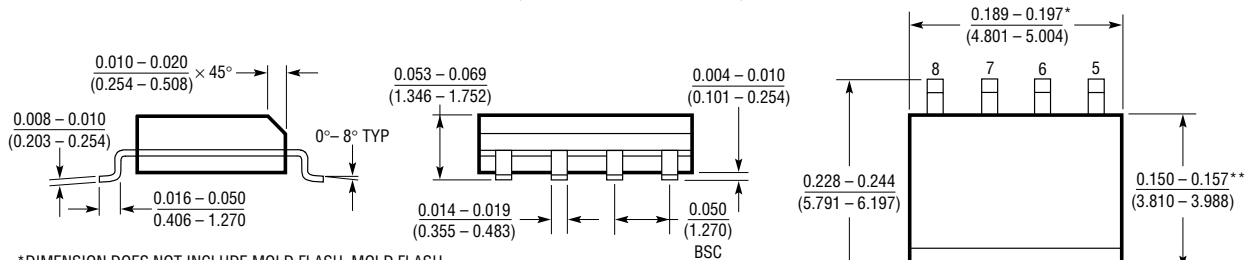



*DIMENSION DOES NOT INCLUDE MOLD FLASH. MOLD FLASH SHALL NOT EXCEED 0.006" (0.152mm) PER SIDE
 **DIMENSION DOES NOT INCLUDE INTERLEAD FLASH. INTERLEAD FLASH SHALL NOT EXCEED 0.010" (0.254mm) PER SIDE

RELATED PARTS

PART NUMBER	DESCRIPTION	COMMENTS
LTC1257	Single 12-Bit V_{OUT} DAC, Full Scale: 2.048V, V_{CC} : 4.75V to 15.75V, Reference Can Be Overdriven Up to 12V, i.e., $FS_{MAX} = 12V$	5V to 15V Single Supply, Complete V_{OUT} DAC in SO-8 Package
LTC1446/LTC1446L	Dual 12-Bit V_{OUT} DACs in SO-8 Package	LTC1446: $V_{CC} = 4.5V$ to $5.5V$, $V_{OUT} = 0V$ to $4.095V$ LTC1446L: $V_{CC} = 2.7V$ to $5.5V$, $V_{OUT} = 0V$ to $2.5V$
LTC1450/LTC1450L	Single 12-Bit V_{OUT} DACs with Parallel Interface	LTC1450: $V_{CC} = 4.5V$ to $5.5V$, $V_{OUT} = 0V$ to $4.095V$ LTC1450L: $V_{CC} = 2.7V$ to $5.5V$, $V_{OUT} = 0V$ to $2.5V$
LTC1451	Single Rail-to-Rail 12-Bit DAC, Full Scale: 4.095V, V_{CC} : 4.5V to 5.5V, Internal 2.048V Reference Brought Out to Pin	Same as LTC1456 Except REF Out Pin Replaces CLR Pin
LTC1452	Single Rail-to-Rail 12-Bit V_{OUT} Multiplying DAC, V_{CC} : 2.7V to 5.5V	Low Power, Multiplying V_{OUT} DAC with Rail-to-Rail Buffer Amplifier in SO-8 Package
LTC1453	Single Rail-to-Rail 12-Bit V_{OUT} DAC, Full Scale: 2.5V, V_{CC} : 2.7V to 5.5V	3V, Low Power, Complete V_{OUT} DAC in SO-8 Package
LTC1454/LTC1454L	Dual 12-Bit V_{OUT} DACs in SO-16 Package with Added Functionality	LTC1454: $V_{CC} = 4.5V$ to $5.5V$, $V_{OUT} = 0V$ to $4.095V$ LTC1454L: $V_{CC} = 2.7V$ to $5.5V$, $V_{OUT} = 0V$ to $2.5V$
LTC1458/LTC1458L	Quad 12 Bit Rail-to-Rail Output DACs with Added Functionality	LTC1458: $V_{CC} = 4.5V$ to $5.5V$, $V_{OUT} = 0V$ to $4.095V$ LTC1458L: $V_{CC} = 2.7V$ to $5.5V$, $V_{OUT} = 0V$ to $2.5V$

Looking for pricing, stock, or lifecycle information?

Click below to explore more details on WIN SOURCE:

-  [View LTC1456CN8#PBF on WIN SOURCE](#)
-  [Analog Devices Inc. Information](#)

Optimize Your Supply Chain with WIN SOURCE Solutions

-  Global Sourcing Solution
-  Obsolete Management
-  Cost Control Management
-  Shortage Management
-  Alternative Solution
-  Excess Inventory Management