



**THE DATASHEET OF
AUIRS2012STR**



Features

- High and low side gate driver
- Fully operational up to 200V
- Floating channel designed for bootstrap operation
- 2A source and sink currents
- Extended supply voltage range: 10V to 20V
- CMOS compatible inputs
- CMOS Schmitt-triggered inputs
- Outputs in phase with inputs
- Under Voltage Lock Out function
- Matched propagation delay times
- Automotive Qualified[†]
- Leadfree, RoHS compliant

Product Summary

Topology	High & Low Side Driver
V_{S-MAX}	200V
V_{OUT}	10V – 20V
I_{o+} & I_{o-}	2 A
t_{ON} & t_{OFF}	60ns (typ)
Delay matching	20ns (max)

Typical Applications

- Mid to low voltage DC-DC Converter for Micro and Mild Hybrid Vehicle
- Multiphase buck boost converters
- Direct Fuel Injection

Package

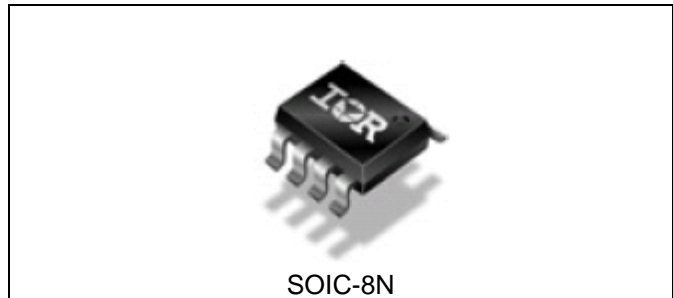

Typical Connection Diagram

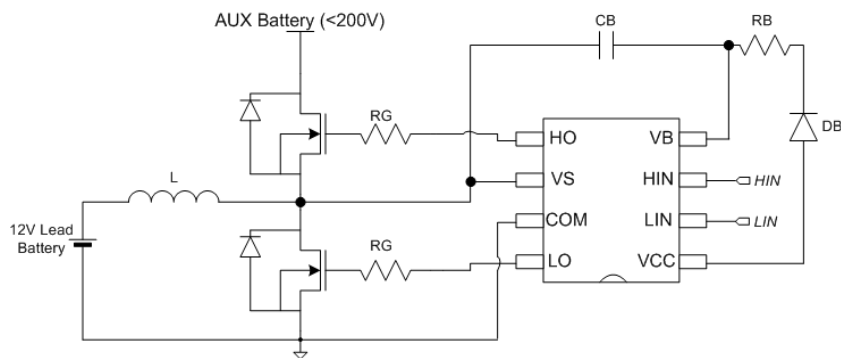

Orderable Part Number	Package Type	Standard Pack		Note
		Form	Quantity	
AUIRS2012STR	SOIC8-N	Tape & Reel	2500	

Absolute Maximum Ratings

Absolute Maximum Ratings indicate sustained limits beyond which damage to the device may occur. All voltage parameters are absolute voltages referenced to COM lead. Stresses beyond those listed under "Absolute Maximum Ratings" may cause permanent damage to the device. These are stress ratings only; and functional operation of the device at these or any other condition beyond those indicated in the "Recommended Operating Conditions" is not implied. Exposure to absolute-maximum-rated conditions for extended periods may affect device reliability. The thermal resistance and power dissipation ratings are measured under board mounted and still air conditions. Ambient temperature (T_A) is 25°C, unless otherwise specified.

Symbol	Definition	Min.	Max.	Units
V_{CC}	Fixed supply voltage	-0.3	20	V
V_{LO}	Low Side output voltage	-0.3	$V_{CC}+0.3$	
V_{IN}	Logic input voltage (HIN & LIN)	-0.3	5.0	
V_B	High side floating supply voltage	-0.3	V_S+20	
V_S	High side floating offset voltage	V_B-20	200	
V_{HO}	High Side floating output voltage	$V_S-0.3$	$V_B+0.3$	
dV_S/dt	Allowable offset transient	-	50	V/ns
R_{thJA}	Thermal resistance, junction to ambient	—	100	°C/W
T_J	Junction temperature	—	150	°C
T_S	Storage temperature	-55	150	
T_L	Lead temperature (soldering, 10 seconds)	—	300	

Recommended Operating Conditions

For proper operation the device should be used within the recommended conditions. All voltage parameters are absolute voltage referenced to COM.

Symbol	Definition	Min.	Max.	Units
V_{CC}	Fixed supply voltage	10	20	V
V_{LO}	Low Side output voltage	0	V_{CC}	
V_{IN}	Logic input voltage (HIN & LIN)	COM	5.0	
V_B	High side floating supply voltage	V_S+10	V_S+20	
V_S	High side floating offset voltage	Note 1	200	
V_{HO}	High Side floating output voltage	V_S	V_B	
F_{sw}	Switching frequency**		400	kHz
R_{in}	Input resistance*	100	5k	Ω
T_A	Ambient Temperature	-40	125	°C

Note 1: Logic operational for V_S of -5V to 200V. Logic state held of -5V to $-V_{BS}$.

* input resistance value to be calculated based on the desired rise time and switching frequency.

** thermal balance to be verified accordingly

Static Electrical Characteristics

Unless otherwise specified, these specifications apply for an operating junction temperature range of $-40^{\circ}\text{C} \leq T_a \leq 125^{\circ}\text{C}$ and power supplies V_{BIAS} (i.e. V_{CC} & V_{BS}) = 15V. The V_{IN} , V_{TH} and I_{IN} parameters are referenced to COM and are applicable to all logic input leads: HIN and LIN. The V_{O} and I_{O} parameters are referenced to GND and are applicable to the output leads: OUTA and OUTB.

Symbol	Definition	Min	Typ	Max	Units	Test Conditions
V_{IL}	Logic "0" input voltage			0.7	V	VCC=10V-20V
V_{IH}	Logic "1" input voltage	2.5				
V_{OL}	Low Level output voltage			0.1		$I_{\text{O}}=20\text{mA}$
V_{OH}	High Level output voltage, $V_{\text{BIAS}} - V_{\text{O}}$			2.45		$I_{\text{O}}=-20\text{mA}$
$I_{\text{IN+}}$	Logic "1" input bias current		40	60	μA	VIN=3.3V
$I_{\text{IN-}}$	Logic "0" input bias current			2		VIN=0V
C_{IN}	Equivalent input capacitance ^(†)		7		pF	
I_{QBS}	Quiescent VBS supply current		100	250	μA	VIN=0V or 3.3V
I_{QCC}	Quiescent VCC supply current		100	250		
I_{LK}	Offset supply leakage current			20		VB=VS=200V
V_{CCUVHYS}	Vcc supply undervoltage hysteresis		1		V	
$V_{\text{CCUV+}}$	Vcc supply undervoltage turn on threshold	6	7	8		
$V_{\text{CCUV-}}$	Vcc supply undervoltage turn off threshold	5	6	7		
V_{BSUVHYS}	Vcc supply undervoltage hysteresis		1			
$V_{\text{BSUV+}}$	Vcc supply undervoltage turn on threshold	6	7	8		
$V_{\text{BSUV-}}$	Vcc supply undervoltage turn off threshold	5	6	7		
$I_{\text{O+}}$	Output high short circuit pulsed current ^(†)		2		A	VO=0V, PW=10us, Ta=25C
$I_{\text{O-}}$	Output high short circuit pulsed current ^(†)		2			VO=15V, PW=10us, Ta=25C

(†) Guaranteed by design

Dynamic Electrical Characteristics

Unless otherwise specified, these specifications apply for an operating junction temperature range of $-40^{\circ}\text{C} \leq T_a \leq 125^{\circ}\text{C}$ and power supplies V_{BIAS} (i.e. V_{CC} & V_{BS}) = 15V, $C_L = 1000\text{pF}$. Refer to Figure 1 for switching time definition.

Symbol	Definition	Min	Typ	Max	Units	Test Conditions
Propagation delay characteristics						
t_{ON}	Turn-on propagation delay	—	60	120	ns	$V_S=0\text{V}$ and 200V
t_{OFF}	Turn-off propagation delay	—	60	120		$V_S=0\text{V}$ and 200V
t_r	Turn-on rise time	—	22	46		
t_f	Turn-off fall time	—	15	35		
DM1	Channel to channel turn on delay matching			20		
DM2	Channel to channel turn off delay matching			20		

Input/Output table

HIN	LIN	HO	LO
L	L	L	L
H	L	H	L
L	H	L	H
H	H	H	H

This table is held true in the voltages ranges defined in the recommended operating conditions section.

Lead Definitions

PIN	Symbol	Description
1	VCC	Supply voltage
2	LIN	Logic input for low side gate driver – in phase with LO
3	HIN	Logic input for high side gate driver – in phase with HO
4	VB	High side floating supply
5	HO	High side gate drive output
6	VS	High side floating supply reference
7	COM	Low side reference
8	LO	Low side gate drive output

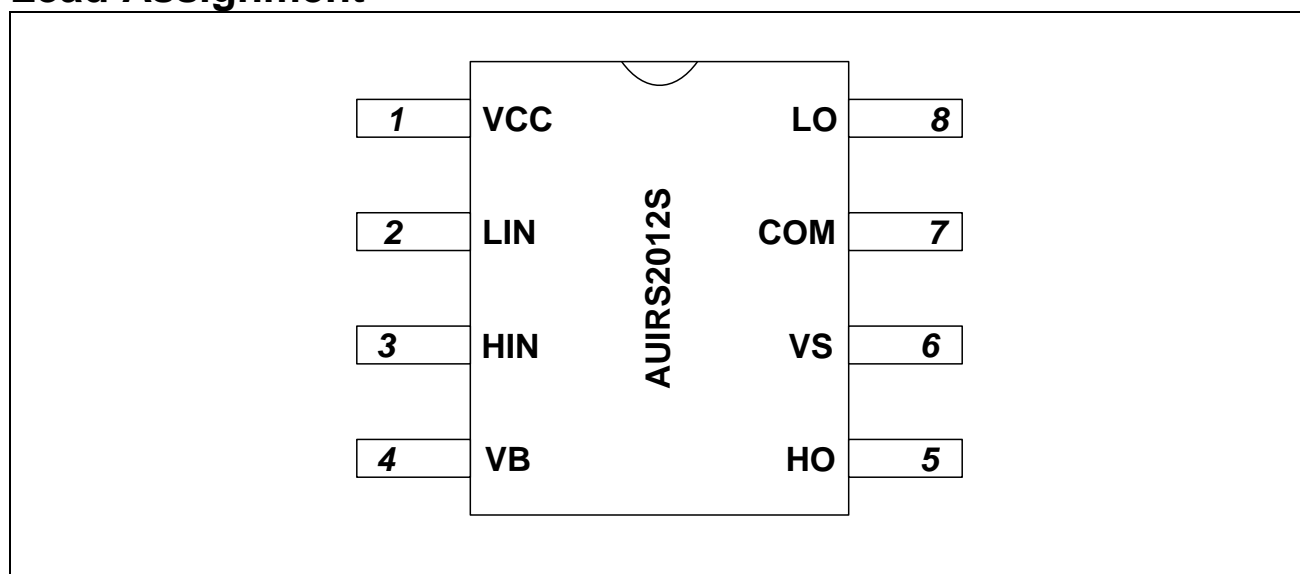
Lead Assignment

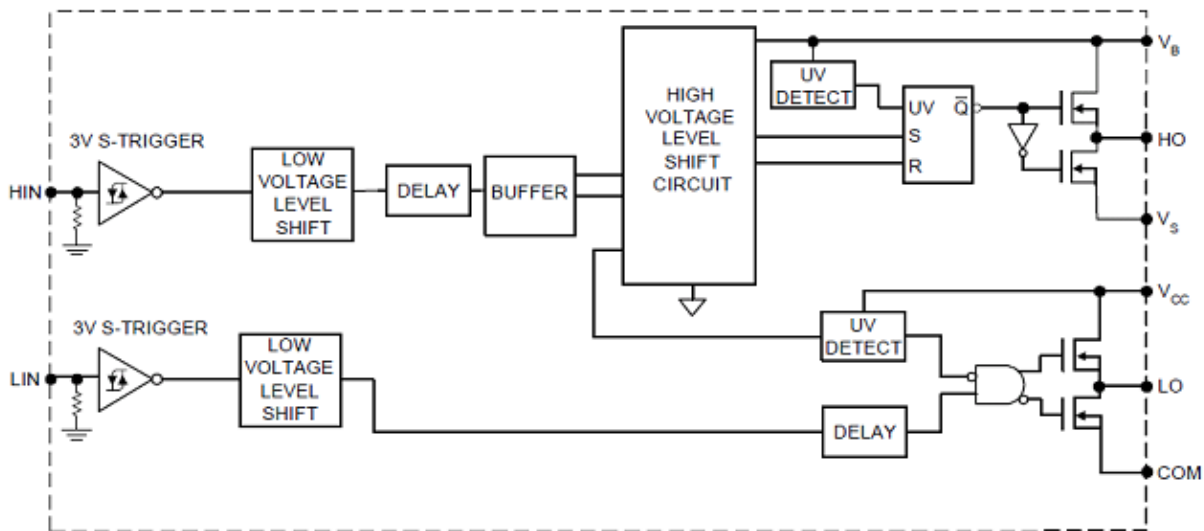
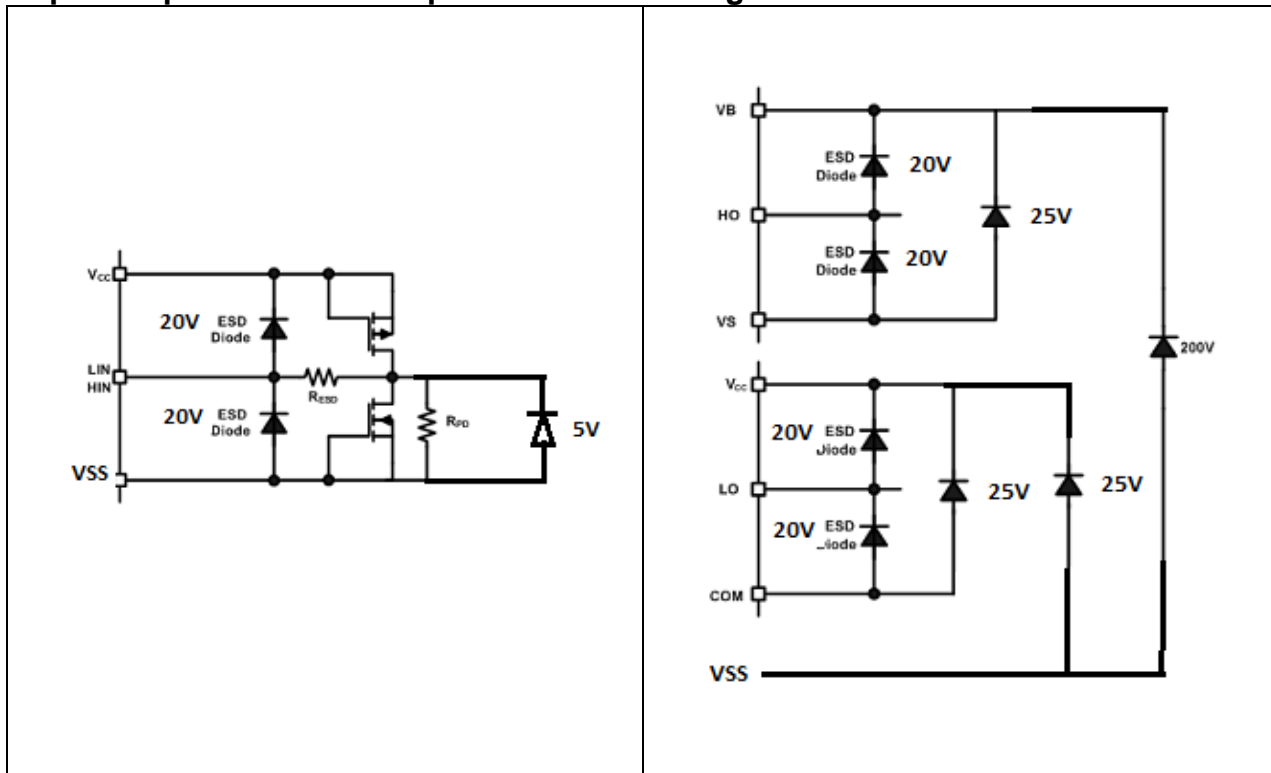
Functional Block Diagram:

Input/Output/Enable Pin Equivalent Circuit Diagrams

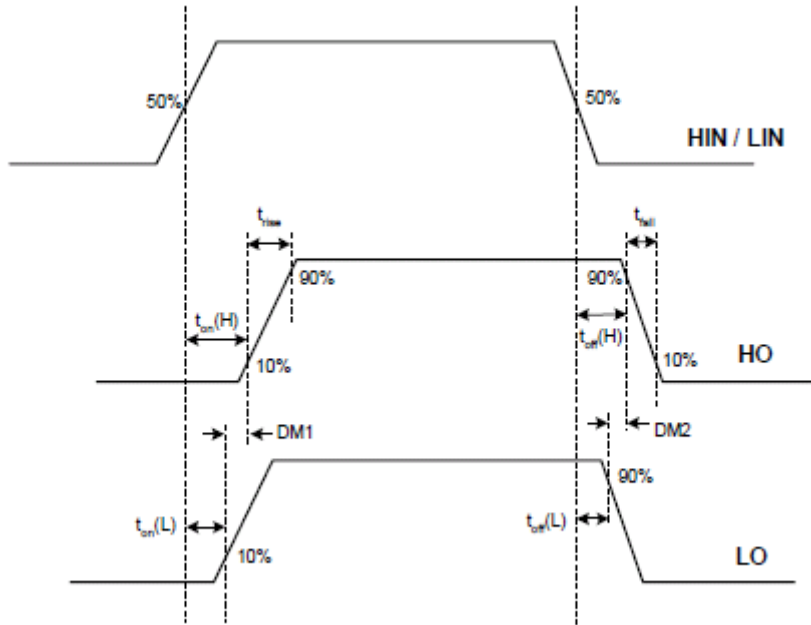
Timing waveforms

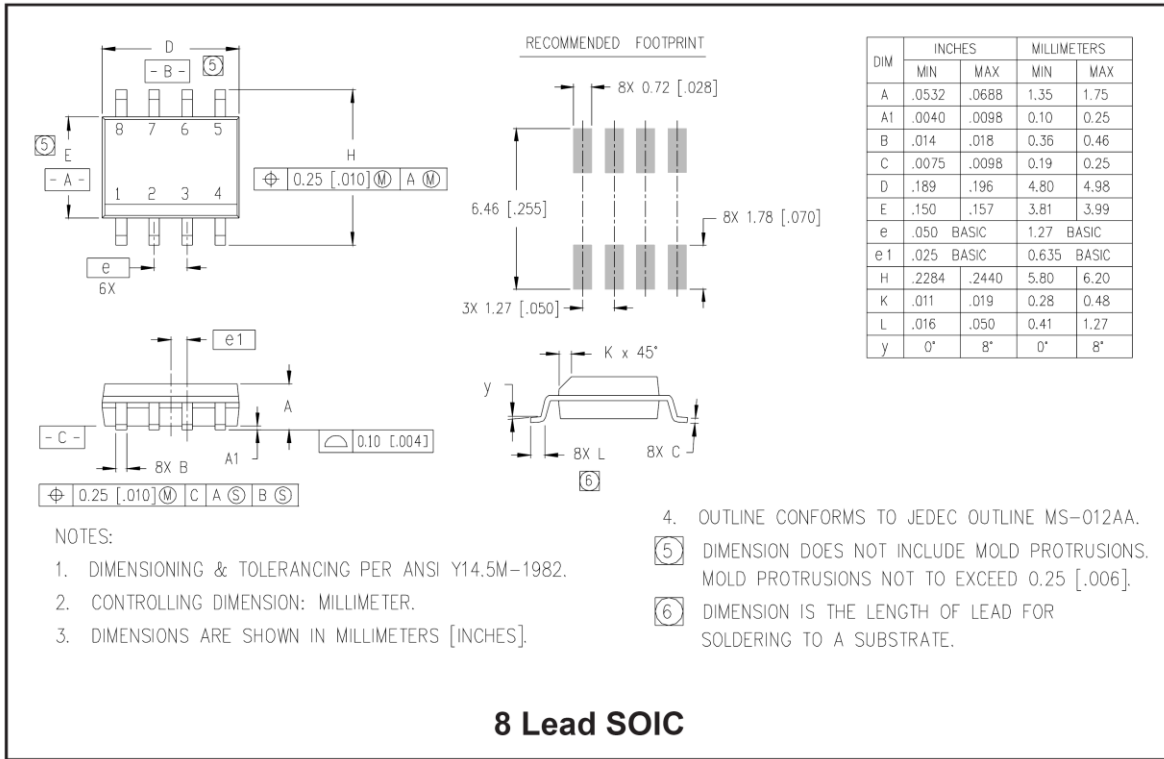

Package Information

Application Information

When using the AUIRS2012S, some precautions have to be taken when very short Hin/Lin pulses are applied. In the following figures, the typical output pulse versus input pulse width distortion is shown, for both HO and LO and for three different input pulse widths.

As an example, applying a 60nsec Lin results in a 60nsec LO only at very low temperatures. As far as Tj increases LO width decreases to a bit more than 40nsec when Tj = Tjmax.

Different is the case when Hin short pulse is applied. Because of the effect of the internal level shifter, the HO pulse width is more stable with temperature.

Output pulse widtht [ns]

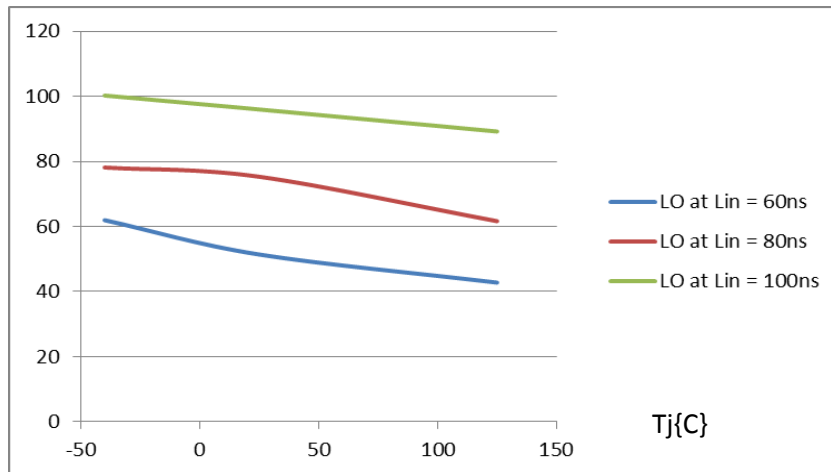

LO Output pulse width vs Input pulse width and Tj

Output pulse widtht [ns]

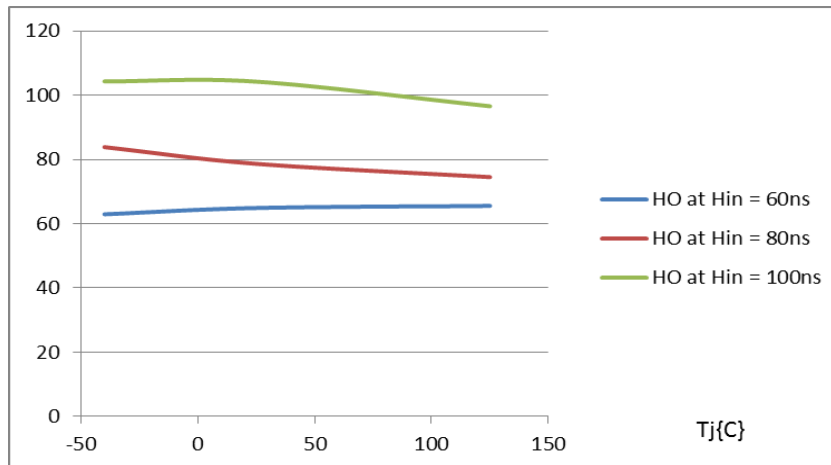

HO Output pulse width vs Input pulse width and Tj

Qualification Information

Qualification Level		Automotive (per AEC-Q100)	
		Comments: This part number passed Automotive qualification. IR's Industrial and Consumer qualification level is granted by extension of the higher Automotive level.	
Moisture Sensitivity Level		SOIC8-N	MSL3,260C (per IPC/JEDEC J-STD-020)
ESD	Machine Model	Class M2 (150V) (per AEC-Q100-003)	
	Human Body Model	Class H2 (2500V) (AEC-Q100-002)	
	Charged Device Model	Class C4 (875V) (per AEC-Q100-011) AEC-Q101-005	
IC Latch-UP Test		Class II, Level A (per AEC-Q100-004)	
RoHS Compliant		Yes	

† Qualification standards can be found at International Rectifier web site: <http://www.irf.com>

IMPORTANT NOTICE

Unless specifically designated for the automotive market, International Rectifier Corporation and its subsidiaries (IR) reserve the right to make corrections, modifications, enhancements, improvements, and other changes to its products and services at any time and to discontinue any product or services without notice. Part numbers designated with the “AU” prefix follow automotive industry and / or customer specific requirements with regards to product discontinuance and process change notification. All products are sold subject to IR’s terms and conditions of sale supplied at the time of order acknowledgment.

IR warrants performance of its hardware products to the specifications applicable at the time of sale in accordance with IR’s standard warranty. Testing and other quality control techniques are used to the extent IR deems necessary to support this warranty. Except where mandated by government requirements, testing of all parameters of each product is not necessarily performed.

IR assumes no liability for applications assistance or customer product design. Customers are responsible for their products and applications using IR components. To minimize the risks with customer products and applications, customers should provide adequate design and operating safeguards.

Reproduction of IR information in IR data books or data sheets is permissible only if reproduction is without alteration and is accompanied by all associated warranties, conditions, limitations, and notices. Reproduction of this information with alterations is an unfair and deceptive business practice. IR is not responsible or liable for such altered documentation. Information of third parties may be subject to additional restrictions.

Resale of IR products or serviced with statements different from or beyond the parameters stated by IR for that product or service voids all express and any implied warranties for the associated IR product or service and is an unfair and deceptive business practice. IR is not responsible or liable for any such statements.

IR products are not designed, intended, or authorized for use as components in systems intended for surgical implant into the body, or in other applications intended to support or sustain life, or in any other application in which the failure of the IR product could create a situation where personal injury or death may occur. Should Buyer purchase or use IR products for any such unintended or unauthorized application, Buyer shall indemnify and hold International Rectifier and its officers, employees, subsidiaries, affiliates, and distributors harmless against all claims, costs, damages, and expenses, and reasonable attorney fees arising out of, directly or indirectly, any claim of personal injury or death associated with such unintended or unauthorized use, even if such claim alleges that IR was negligent regarding the design or manufacture of the product.

Only products certified as military grade by the Defense Logistics Agency (DLA) of the US Department of Defense, are designed and manufactured to meet DLA military specifications required by certain military, aerospace or other applications. Buyers acknowledge and agree that any use of IR products not certified by DLA as military-grade, in applications requiring military grade products, is solely at the Buyer’s own risk and that they are solely responsible for compliance with all legal and regulatory requirements in connection with such use.

IR products are neither designed nor intended for use in automotive applications or environments unless the specific IR products are designated by IR as compliant with ISO/TS 16949 requirements and bear a part number including the designation “AU”. Buyers acknowledge and agree that, if they use any non-designated products in automotive applications, IR will not be responsible for any failure to meet such requirements.

For technical support, please contact IR’s Technical Assistance Center
<http://www.irf.com/technical-info/>

WORLD HEADQUARTERS:

101 N. Sepulveda Blvd., El Segundo, California 90245
 Tel: (310) 252-7105

Looking for pricing, stock, or lifecycle information?

Click below to explore more details on WIN SOURCE:

-  [View AUIRS2012STR](#) on WIN SOURCE
-  [Infineon Technologies](#) Information

Optimize Your Supply Chain with WIN SOURCE Solutions

-  Global Sourcing Solution
-  Obsolete Management
-  Cost Control Management
-  Shortage Management
-  Alternative Solution
-  Excess Inventory Management