



**THE DATASHEET OF  
RAJ240100A20GFP#HC2**



## 1. INTRODUCTION

### 1.1 Features

- **Fully integrated battery management solution with battery capacity measurement and programmable protection capability.**
- **Supports up to 10 Li-ion or Li-Polymer battery cells in series. RAJ240090 supports 3 to 8 series cells, RAJ240100 supports 3 to 10 series cells.**
- **Integrated with Renesas Ultra Low Power RL78 CPU core for multi-function process.**
- **Memory**
  - Code flash memory: 128 kB
  - Data flash memory (up to 100,000 erase/write cycles): 4 kB
  - SRAM: 7 kB
- **Clock generator**
  - High speed on-chip oscillator: up to 32 MHz
  - Low speed on-chip oscillator: 32 kHz
  - AFE high speed on-chip oscillator: 4.194 MHz
  - AFE low speed on-chip oscillator: 131.072 kHz
- **General Purpose I/O Ports**
  - Total: 31 pins
  - CMOS input/output: 20
  - CMOS input: 4
  - N-ch open drain input/output [6V tolerance]: 4
  - High voltage input/output [VCC tolerance]: 3
- **Serial interface**
  - CSI (SPI): 2 channels
  - I2C: 1 channel
  - UART: 2 channels
  - Simplified I2C: 2 channels
  - CAN interface (RS-CAN lite): 1 channel
- **Timer**
  - MCU 16-bit timer: 6 channels
  - MCU 12-bit interval timer: 1 channel
  - MCU Real time clock: 1 channel
  - AFE timer: 2 channels
    - AFE timer A: setting range: 125 ms to 64 s
    - AFE timer B: setting range : 30.52 us to 125 ms
- **Embedded A/D converter**
  - AFE 15-bit resolution sigma-delta A/D converter
  - MCU 8/10-bit resolution A/D converter
- **Battery cell voltage and temperature (AN port voltage) detection circuit**
  - Monitoring over/under voltage and temperature by Sigma-delta AD converter (AFE) without controlling from MCU
- **Current integration circuit**
  - 18-bit resolution sigma-delta A/D converter
- **Impedance measurement circuit**
  - Simultaneous measurement of battery voltage and current
- **Over current detection circuit**
  - Short circuit current detection
  - Charge overcurrent detection
  - Discharge overcurrent detection
  - Charge wakeup current detection
  - Discharge wakeup current detection
- **Series regulator**
  - 3.3 V or 5.0 V CREG2
  - Over 100 mA output current by external Nch MOSFET
- **Charge and Discharge MOSFET control**
  - High side Nch MOSFET drive circuit embedded
  - Programmable MOSFET control by 8-bit PWM
- **Support RTC function**
  - To connect External crystal resonator (32.768 kHz) and generate internal clock.
- **Voltage and temperature condition**
  - Power supply voltage: VCC = 4.0 to 50 V
  - Operating ambient temperature
    - $T_A = -20$  to  $85^\circ\text{C}$  (REG2T6 bit = 0)
    - $T_A = -40$  to  $85^\circ\text{C}$  (REG2T6 bit = 1)
  - Operating ambient temperature is configurable by REG2T6 bit of REG2T register setting.
- **Package Information**
  - 64 pin plastic mold LQFP
  - ([Body] 10.0 mm x 10.0 mm, 0.5 mm pitch)

### 1.2 Applications

- E-Bike, E-Scooter, Pedal-Assist Bicycle
- Power Tool, Vacuum Cleaner, Drone
- Battery Backup System, Energy Storage System (ESS)

### 1.3 Description

RAJ240090 / RAJ240100 are Renesas Li-ion battery fuel gauge IC (FGIC) which consist of a MCU device and an AFE device in a single package. Pack with a variety of battery management features and Renesas RL78 CPU core which has multiple low power modes and capable of achieving high performance in ultra-low power operation. RAJ240090 / RAJ240100 fuel gauge IC have control firmware stored in embedded flash memory to control attached embedded analog and digital circuits to execute battery voltage / current / temperature measurement, remaining capacity estimation, over current / voltage / temperature protection and other battery management operations.

## Table of Contents

1.	INTRODUCTION .....	1
1.1	Features.....	1
1.2	Applications.....	1
1.3	Description .....	1
2.	OUTLINE .....	3
2.1	Outline of Functions .....	3
2.2	RAJ240090 Pin Configuration.....	5
2.3	RAJ240100 Pin Configuration.....	6
3.	PIN FUNCTIONS.....	7
3.1	Pin identification.....	7
3.2	Pin Functions .....	9
3.3	Pin Block Diagram .....	12
4.	ELECTRICAL SPECIFICATIONS.....	24
4.1	Absolute Maximum Ratings .....	24
4.2	Power supply voltage condition.....	26
4.3	Supply current characteristics .....	26
4.4	Oscillator Characteristics .....	27
4.5	Pin characteristics.....	28
4.6	AC Characteristics .....	33
4.7	MCU peripheral circuit characteristics.....	37
4.8	AFE peripheral circuit characteristics.....	53
4.9	RAM Data Retention Characteristics .....	60
4.10	Flash Memory Programming Characteristics.....	60
4.11	Dedicated Flash Memory Programmer Communication (UART).....	60
4.12	Timing of Entry to Flash Memory Programming Modes.....	61
5.	DETAILED DESCRIPTION.....	62
5.1	Overview .....	62
5.2	System block diagram.....	62
5.3	MCU block diagram .....	63
5.4	AFE block diagram.....	64
6.	APPLICATION GUIDELINE.....	65
6.1	Typical Application Specification.....	65
6.2	Typical Application Circuit.....	66
6.3	Circuit Design Guideline.....	67
6.4	Layout Guidelines .....	78
7.	PACKAGE DRAWINGS.....	84
	REVISION HISTORY .....	86

## 2. OUTLINE

### 2.1 Outline of Functions

Caution This outline describes the functions at the time when Peripheral I/O redirection register 0 (PIOR0) is set to "00H".

(1/2)

Item		Description
Code flash memory		128 kB
Data Flash memory		4 kB
RAM		7 kB
Address size		1 MB
Main system clock	High speed on-chip Oscillator clock(fIH)	HS (high-speed main) mode: 1 to 32 MHz LS (low-speed main) mode: 1 to 8 MHz
Subsystem clock		XT1 (crystal) oscillation, external subsystem clock input (EXCLKS) 32.768 kHz
Low speed on-chip oscillator clock		15 kHz (TYP.)
General purpose register		8 bits × 32 registers (8 bits × 8 registers × 4 banks)
Minimum instruction execution time		0.03125 us (Internal high speed oscillation clock: fIH = 32 MHz) 30.5 us (Subsystem clock: f <sub>SUB</sub> = 32.768 kHz operation)
Instruction set		<ul style="list-style-type: none"> <li>• Data transmission (8/16 bits)</li> <li>• Addition and subtraction/logical operations (8/16 bits)</li> <li>• Multiplication (8×8 bits, 16×16 bits), Division (16÷16 bits, 32÷32 bits)</li> <li>• Multiplication and Accumulation (16 bits × 16 bits + 32 bits)</li> <li>• Rotate, barrel shift, bit manipulation (set, reset, test, Boolean operation) etc.</li> </ul>
I/O Port	CMOS I/O	20
	CMOS input	4
	N-ch open-drain I/O [6V tolerance)	4
	High voltage I/O	3
Timer	16-bit timer	6 channels (TAU : 4 channels, Timer RD : 2 channels)
	Watchdog timer	1 channel
	Real time clock	1 channel
	12-bit interval timer	1 channel
	Timer output	Timer outputs: 6 channels PWM outputs: 3 channels
	RTC output	1 channel
8/10-bit resolution A/D converter		4 channels
Serial interface		<ul style="list-style-type: none"> <li>• CSI: 1 channel/UART: 1 channel/simplified I2C: 1 channel</li> <li>• CSI: 1 channel/UART: 1 channel/simplified I2C: 1 channel</li> </ul>
	I <sup>2</sup> C bus	1 channel
	Can interface (RS-CAN lite)	1 channel
Vector interrupt source	Internal	22
	External	15 (6 sources is connected to AFE in the chip)
Reset		<ul style="list-style-type: none"> <li>• Reset by RESET pin (reset circuit output of AFE connected to RESETOUT)</li> <li>• Internal reset by watchdog timer</li> <li>• Internal reset by illegal instruction execution <sup>Note</sup></li> <li>• internal reset by RAM parity error</li> <li>• internal reset by illegal memory access</li> </ul>
On-chip debug function		Support

**Note** The illegal instruction execution is generated when instruction code FFH is executed. Reset by the illegal instruction execution is not issued by emulation with the in-circuit emulator or on-chip debug emulator.

(2/2)

Item	Description
PWM	8 bits or 10 bits x1 for FET control
Sigma-delta A/D converter	15-bit resolution (sigma-delta method) <ul style="list-style-type: none"> <li>• Battery Cell voltage (Cell 1 to 8 in RAJ240090, Cell 1 to 10 in RAJ240100)</li> <li>• Battery Cell total voltage (VIN8 pin in RAJ240090, VIN10 pin in RAJ240100)</li> <li>• Charge voltage (PACK pin)</li> <li>• PON pin input voltage</li> <li>• Thermistor sensor port with on-chip pull-up 10 kΩ resistor: 3 channels</li> <li>• On-chip simple temperature sensor (temperature range: -40 to 85°C)</li> <li>• Internal reference and supply voltage (MCU and AFE)</li> </ul>
Battery cell voltage and temperature (AN port voltage) detection circuit	Battery Cell voltage detection <ul style="list-style-type: none"> <li>• Over voltage (Overcharge voltage)</li> <li>• Under voltage (Overdischarge voltage)</li> </ul> Temperature (AN port voltage) detection <ul style="list-style-type: none"> <li>• Over temperature</li> <li>• Under temperature</li> </ul>
Current integrating circuit	1 channel:18-bit resolution
Current integrating circuit for impedance measurement	1 channel:15-bit resolution
Overcurrent detection circuit and wake up current detection circuit	<ul style="list-style-type: none"> <li>• Discharge short-circuit current detection</li> <li>• Discharge overcurrent detection</li> <li>• Charge overcurrent detection,</li> <li>• Wake up current detection (discharge and charge)</li> </ul>
Simple temperature sensor	1 channel
Charge/Discharge FET control circuit	NchFET driver for charge control NchFET driver for discharge control
Power on reset circuit	Return from power down mode by detecting voltage and connecting charger
Series regulator	VREG2 : power supply for MCU (3.3 V or 5.0 V)
Reset circuit	Series regulator output monitoring (VREG2)
Cell balancing circuit	8 series cells support in RAJ240090 10 series cells support in RAJ240100 (On-resistor: 200 Ω TYP)
MCU runaway detection circuit	20 bitsx1(2 / 4 / 8 / 16 / 32 / 64 [s] to be selected)
AFE On-chip oscillator	4.194 MHz (TYP)
AFE low speed On-chip oscillator	131.972 kHz (TYP)
AFE timer	2 channels <ul style="list-style-type: none"> <li>• AFE timer A (setting range : 125 ms to 64 s)</li> <li>• AFE timer B (setting range : 30.52 us to 125 ms)</li> </ul>
MCU-AFE communication interface(C2C)	AFE ~ MCU communication (Chip to Chip Interface)
Power supply voltage	VCC = 4.0 to 50 V
Operation ambient temperature	-20 to 85°C (REG2T6 bit (bit6 of REG2T) = 0) -40 to 85°C (REG2T6 bit (bit6 of REG2T) = 1)
Package	64 pin plastic mold LQFP([Body] 10.0 mm x 10.0 mm, 0.5 mm pitch, 1.4 mm thickness)





### 3. PIN FUNCTIONS

#### 3.1 Pin identification

(1/2)

No.	Name	Type	Description
1	RESETOUT	AO	Reset Output
2	AN2	AIN	Analog Input
3	AN1	AIN	Analog Input
4	AN0	AIN	Analog Input
5	GND1	P	Ground
6	CREG2S	P	Regulator Sense
7	CREG2F	P	Regulator Force
8	NC	NC	No connect
9	VCC	P	Power supply
10	PON	HVIN	High voltage Port for power on
11	PACK	HVIN	Charger voltage input
12	DFOUT	HVO	Discharge MOSFET control
13	CFOUT	HVO	Charge MOSFET control
14	VBAT	AIN	Battery voltage input
15	VIN10 for RAJ240100, VIN8 for RAJ240090	AIN	Battery voltage input
16	VIN9 for RAJ240100, NC for RAJ240090	AIN / NC	Battery voltage input (NC for RAJ240090)
17	VIN8 for RAJ240100, NC for RAJ240090	AIN / NC	Battery voltage input (NC for RAJ240090)
18	VIN7	AIN	Battery voltage input
19	VIN6	AIN	Battery voltage input
20	VIN5	AIN	Battery voltage input
21	VIN4	AIN	Battery voltage input
22	VIN3	AIN	Battery voltage input
23	VIN2	AIN	Battery voltage input
24	VIN1	AIN	Battery voltage input
25	VIN0	AIN	Battery voltage input
26	GND0	P	Ground
27	ISENS0	AIN	Analog input for current integration circuit
28	ISENS1	AIN	Analog input for current integration circuit
29	NC	NC	No connect
30	HVP2	HVIO	High Voltage Port
31	HVP1	HVIO	High Voltage Port
32	HVP0	HVIO	High Voltage Port
33	P23 / ANI0 / AVREFP	DIO/AIN	Port2 / Analog Input / Analog Reference Voltage Plus
34	P22 / ANI1 / AVREFM	DIO/AIN	Port2 / Analog Input / Analog Reference Voltage Minus
35	P21 / ANI2	DIO/AIN	Port2 / Analog Input
36	P20 / ANI3	DIO/AIN	Port2 / Analog Input
37	P07 / TI00 / TO00	DIO	Port0 / Timer Input / Timer Output
38	P06 / TI01 / TO01	DIO	Port0 / Timer Input / Timer Output

(2/2)

No.	Name	Type	Description
39	P05 / TI02 / TO02	DIO	Port0 / Timer Input / Timer Output
40	P04 / CRXD0	DIO	Port0 / CAN Receive Data
41	P03 / CTXD0	DIO	Port0 / CAN Transmit Data
42	P02 / TRDIOD0	DIO	Port0 / Timer Output
43	P01 / TRDIOC0	DIO	Port0 / Timer Output
44	P00 / TRDIOB0	DIO	Port0 / Timer Output
45	P63 / INTP4 / (SI10) / (SDA10) / (RXD1)	DIO	Port6 / External Interrupt Input / Serial Data Input / Serial Data Input/Output / Receive Data
46	P62 / INTP5 / (SI00) / (SDA00) / (RXD0)	DIO	Port6 / External Interrupt Input / Serial Data Input / Serial Data Input/Output / Receive Data
47	P61 / INTP6 / SDAA0	DIO	Port6 / External Interrupt Input / I2C Bus data I/O
48	P60 / INTP7 / SCLA0	DIO	Port6 / External Interrupt Input / I2C Bus clock I/O
49	P16 / INTP0	DIO	Port1 / External Interrupt Input
50	P15 / SO10 / TXD1	DIO	Port1 / Serial Data Output / Transmit Data
51	P14 / INTP1 / SI10 / SDA10 / RXD1	DIO	Port1 / External Interrupt Input / Serial Data Input / Serial Data Input/Output / Receive Data
52	P13 / SCK10 / SCL10	DIO	Port1 / Serial Clock Input/Output
53	P12 / SO00 / TXD0 / RTC1HZ	DIO	Port1 / Serial Data Output / Transmit Data / Real-time Clock Correction Clock (1 Hz) Output
54	P11 / INTP2 / SI00 / SDA00 / RXD0	DIO	Port1 / External Interrupt Input / Serial Data Input / Serial Data Input/Output / Receive Data
55	P10 / SCK00 / SCL00	DIO	Port1 / Serial Clock Input/Output
56	P40 / TOOL0	DIO	Port4 / Data Input/Output for Tool
57	RESET	DIN	Reset Input for MCU
58	P124 / XT2 / EXCLKS	DI	Port12 / Crystal Oscillator Input / External Clock Input
59	P123 / XT1	DI	Port12 / Crystal Oscillator Input
60	P137 / INTP3	DI	Port13 / External Interrupt Input
61	P122/EXCLK	DI	Port12 / External Clock Input
62	REGC	P	Regulator Capacitance
63	VSS	P	Ground
64	VDD	P	Power Supply

**Remark** Functions in parentheses in the above figure can be assigned via settings in the peripheral I/O redirection register 0 (PIOR0).

**HVO:** high voltage output

**HVIN:** high voltage input

**HVIO:** high voltage input/output

**P:** power

**DIO:** digital I/O

**DIN:** digital input

**AIN:** analog input

**AO:** analog output

## 3.2 Pin Functions

### 3.2.1 Pin type and alternate functions

Function name	Pin Type	I/O	After Reset Release	Alternate Function	Function
P00	7-1-7	I/O	Input port	TRDIOB0	Port 0. 8-bit I/O port. Input/output can be specified in 1-bit unit. Use of an on-chip pull-up resistor can be specified by a software setting at input port. Input of P03 and P04 can be set to TTL input buffer. Output of P03 and P04 can be set to N-ch open-drain output (VDD tolerance).
P01	7-1-7			TRDIOC0	
P02	7-1-7			TRDIOD0	
P03	8-1-4			CTXD0	
P04	8-1-4			CRXD0	
P05	7-1-3			TI02/TO02	
P06	7-1-3			TI01/TO01	
P07	7-1-3			TI00/TO00	
P10	8-1-4	I/O	Input port	SCK00/SCL00	Port 1. 7-bit I/O port. Input/output can be specified in 1-bit unit. Use of an on-chip pull-up resistor can be specified by a software setting at input port. Input of P10 to P14 can be set to TTL input buffer. Output of P10 to P16 can be set to N-ch open-drain output (VDD tolerance).
P11	8-1-4			INTP2/SI00/SDA00/RXD0	
P12	7-1-4			SO00/TXD0/RTC1HZ	
P13	8-1-4			SCK10/SCL10	
P14	8-1-4			INTP1/SI10/SDA10/RXD1	
P15	7-1-4			SO10/TXD10	
P16	7-1-4			INTP0	
P20	4-3-3			I/O	
P21	4-3-3	ANI2			
P22	4-3-3	ANI1/AVREFM			
P23	4-3-3	ANI0/AVREFP			
P30	7-1-3	I/O	Input port	INTP13	Port 3. <sup>Note 2</sup> 4-bit I/O port. Input/output can be specified in 1-bit unit. Use of an on-chip pull-up resistor can be specified by a software setting at input port.
P31	7-1-3			INTP12	
P32	7-1-3			INTP11	
P33	7-1-3			INTP10	
P40	7-1-3	I/O	Input port	TOOL0	Port 4. 1-bit I/O port. Input/output can be specified in 1-bit unit. Use of an on-chip pull-up resistor can be specified by a software setting at input port.
P60	12-1-2	I/O	Input port	INTP7/SCLA0	Port 6. 4-bit I/O port. Input/output can be specified in 1-bit unit. Output of P60 to P63 can be set to N-ch open-drain output (6.0V tolerance).
P61	12-1-2			INTP6/SDAA0	
P62	12-1-2			INTP5/(SI00)/(SDA00)/(RXD0)	
P63	12-1-2			INTP4/(SI10)/(SDA10)/(RXD1)	
P70	7-1-3	I/O	Input port	INTP9	Port 7. <sup>Note 2</sup> 8-bit I/O port. Input/output can be specified in 1-bit unit. Use of an on-chip pull-up resistor can be specified by a software setting at input port.
P71	7-1-3			INTP8	
P72	7-1-3			EXBSEL	
P73	7-1-3			EXBCK	
P74	7-1-3			EXBO0/EXBI0	
P75	7-1-3			EXBO1/EXBI1	
P76	7-1-3			EXBO2/EXBI2	
P77	7-1-3			EXBO3/EXBI3	
P122	2-2-2	input	Input port	EXCLK	Port 12. 3-bit input-only port.
P123	2-2-1			XT1	
P124	2-2-1			XT2/EXCLKS	
P137	2-1-2	input	Input port	INTP3	Port 13. 1-bit input-only port.
RESET	2-1-1	input	-	-	Input-only pin for external reset. Connect to VDD directly or via a resistor when external reset is not used.

**Note 1.** Each pin can be configured as digital or analog pin by setting the port mode in the control register x (PMCx) (Can be specified in 1-bit units).

**Note 2.** Connected to internal AFE circuit.

## 3.2.2 External Pin Functions

(1/2)

Category	Pin name	I/O	Function
Power supply	VCC	–	Power supply input Apply power supply voltage to VCC pin from a charger or battery.
	GND0, GND1	–	Device ground input. Connect the negative input terminal of lithium-ion battery 1 to the GND0 and GND1 pins
	CREG2F	–	Series regulator force port
	CREG2S	–	Series regulator sense port Connect to GND0 and GND1 via a capacitor (1 uF to 4.7 uF)
	VDD	–	Positive power supply for MCU Connect to CREG2
	VSS	–	Ground input for MCU Connect the negative input terminal of lithium-ion battery 1 to the GND0 and GND1 pins
	REGC <sup>Note 1.</sup>	–	Pin for connecting regulator output stabilization capacitance for internal operation. Connect this pin to VSS via a capacitor (0.47 to 1 uF). Also, use a capacitor with good characteristics, since it is used to stabilize internal voltage.
RESET	RESET	Input	This is the active-low system reset input pin for MCU.
	RESETOUT	output	This is the active-low system reset output pin for AFE.
TOOL0	TOOL0 <sup>Note 2</sup>	input	Data I/O for flash memory programmer/debugger. Connect to the VDD via an external pull-up resistor in the on chip debug mode
Serial interface (UART0, UART1)	RxD0, RxD1	input	Serial data input pins of serial interface UART0 to UART1
	TxD0, TxD1	output	Serial data output pins of serial interface UART0 to UART1
Serial interface (CSI00, CSI10)	SCK00, SCK10	I/O	Serial clock I/O pins of serial interface CSI00 and CSI10
	SI00, SI10	input	Serial data input pins of serial interface CSI00 and CSI10
	SO00, SO10	output	Serial data output pins of serial interface CSI00 and CSI10
Serial interface (IIC00, IIC10)	SCL00, SCL10	output	Serial clock output pins of serial interface IIC00 and IIC10
	SDA00, SDA10	I/O	Serial data I/O pins of serial interface IIC00 and IIC10
Serial interface (IICA0)	SCLA0	I/O	Serial clock I/O pins of serial interface IICA0
	SDAA0	I/O	Serial data I/O pins of serial interface IICA0,
CAN-BUS interface	CRXD0	input	CAN serial data input
	CTXD0	output	CAN serial data output
A/D converter	AN0, AN1, AN2	input	AFE A/D converter analog input
	ANI0, ANI1, ANI2, ANI3	input	MCU A/D converter analog input
	AVREFP	input	A/D converter reference voltage (+ side).
	AVREFM	input	A/D converter reference voltage (- side).
Current integration circuit and overcurrent detection circuit	ISENS0, ISENS1	input	Analog input for current integration circuit and over current detection circuit
Timer	TI00-TI02	input	The pins for inputting an external count clock/capture trigger to 16-bit timers 00 to 02
	TO00-TO02	output	Timer output pins of 16-bit timers 00 to 02
	TRDIOB0 TRDIOC0 TRDIOD0	I/O	Timer RD input/output
	RTC1HZ	output	Real-time clock supports clock (1 Hz) output

(2/2)

Category	Pin name	I/O	Function
High voltage I/O port	HVP0, HVP1, HVP2	I/O	High voltage I/O in correspondence with VCC tolerance
Subsystem clock	XT1, XT2 <sup>Note 3</sup>	—	Resonator connection for subsystem clock
External clock	EXCLK	Input	External clock input for main system clock
	EXCLKS	input	External clock input for subsystem clock
External interrupt input	INTP0 to INTP13	input	Interrupt request input pin. INTP8 to INTP13 connects interrupt request signal of AFE in the package and do not connect to any pin
Power on circuit	PON	input	Power on input for release from power down state
Charger connection detect	PACK	Input	Charger voltage input and source voltage of discharge FET drive port (DFOUT)
Battery connection detect	VBAT	input	Sense voltage input pin for most positive cell and source voltage for charge FET drive port (CFOUT)
Battery voltage detection circuit	VIN10 <sup>Note 4</sup>	input	The positive input terminal of lithium-ion battery 10.
	VIN9 <sup>Note 4</sup>	Input	The negative input terminal of lithium-ion battery 10 and the positive input terminal of lithium-ion battery 9
	VIN8	Input	The negative input terminal of lithium-ion battery 9 and the positive input terminal of lithium-ion battery 8
	VIN7	Input	The negative input terminal of lithium-ion battery 8 and the positive input terminal of lithium-ion battery 7
	VIN6	Input	The negative input terminal of lithium-ion battery 7 and the positive input terminal of lithium-ion battery 6
	VIN5	Input	The negative input terminal of lithium-ion battery 6 and the positive input terminal of lithium-ion battery 5
	VIN4	Input	The negative input terminal of lithium-ion battery 5 and the positive input terminal of lithium-ion battery 4
	VIN3	Input	The negative input terminal of lithium-ion battery 4 and the positive input terminal of lithium-ion battery 3
	VIN2	Input	The negative input terminal of lithium-ion battery 3 and the positive input terminal of lithium-ion battery 2
	VIN1	Input	The negative input terminal of lithium-ion battery 2 and the positive input terminal of lithium-ion battery 1
	VIN0	Input	The negative input terminal of lithium-ion battery 1
FET control output	DFOUT	Output	ON/OFF signal output pin for discharge FET.
	CFOUT	Output	ON/OFF signal output pin for charge FET.
Communication between AFE and MCU	P72	input	Control signal of communication between AFE and MCU with setting to output port. P72 is connected to AFE in a package and not external pin.
	EXBCK	Output	Clock signal of communication between AFE and MCU
	EXBD0-3	I/O	Data signal of communication between AFE and MCU

**Note 1.** REGC is not external power supply pin. (Do not draw current from REGC.)

**Note 2.** After reset release, the connection between P40/TOOL0 and the operating mode are as follows.

**Table 3-1 TOOL0 Pin Operation Mode after Reset Release**

P40/TOOL0	Operation Mode
VDD	Normal operation mode
0V	Flash memory programming mode

**Note 3.** Figure 3-1 shows an example of the external circuit for the XT1 oscillator.

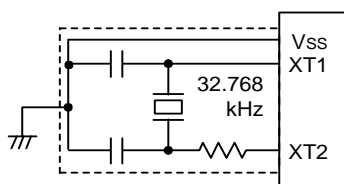

**Figure 3-1 Example of External Circuit for XT1 Oscillator**

**Note 4.** VIN10 pin and VIN9 pin are only applicable to RAJ240100.

### 3.3 Pin Block Diagram

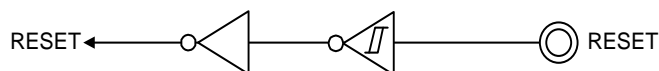
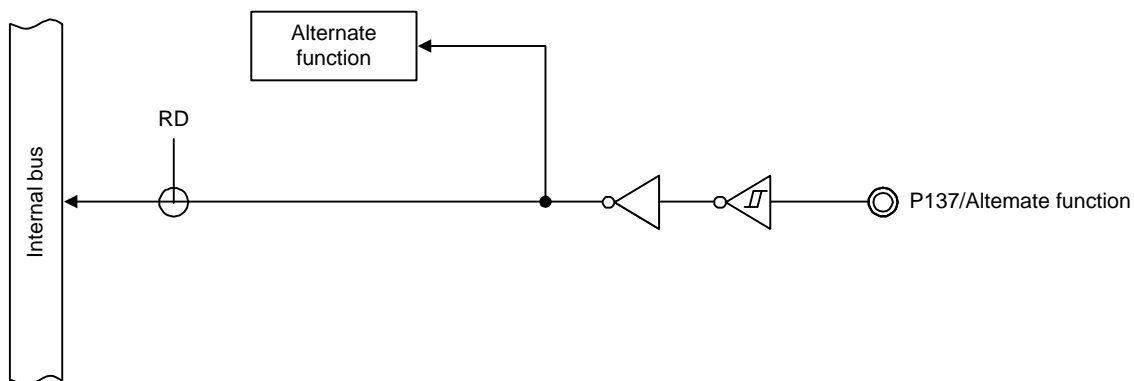
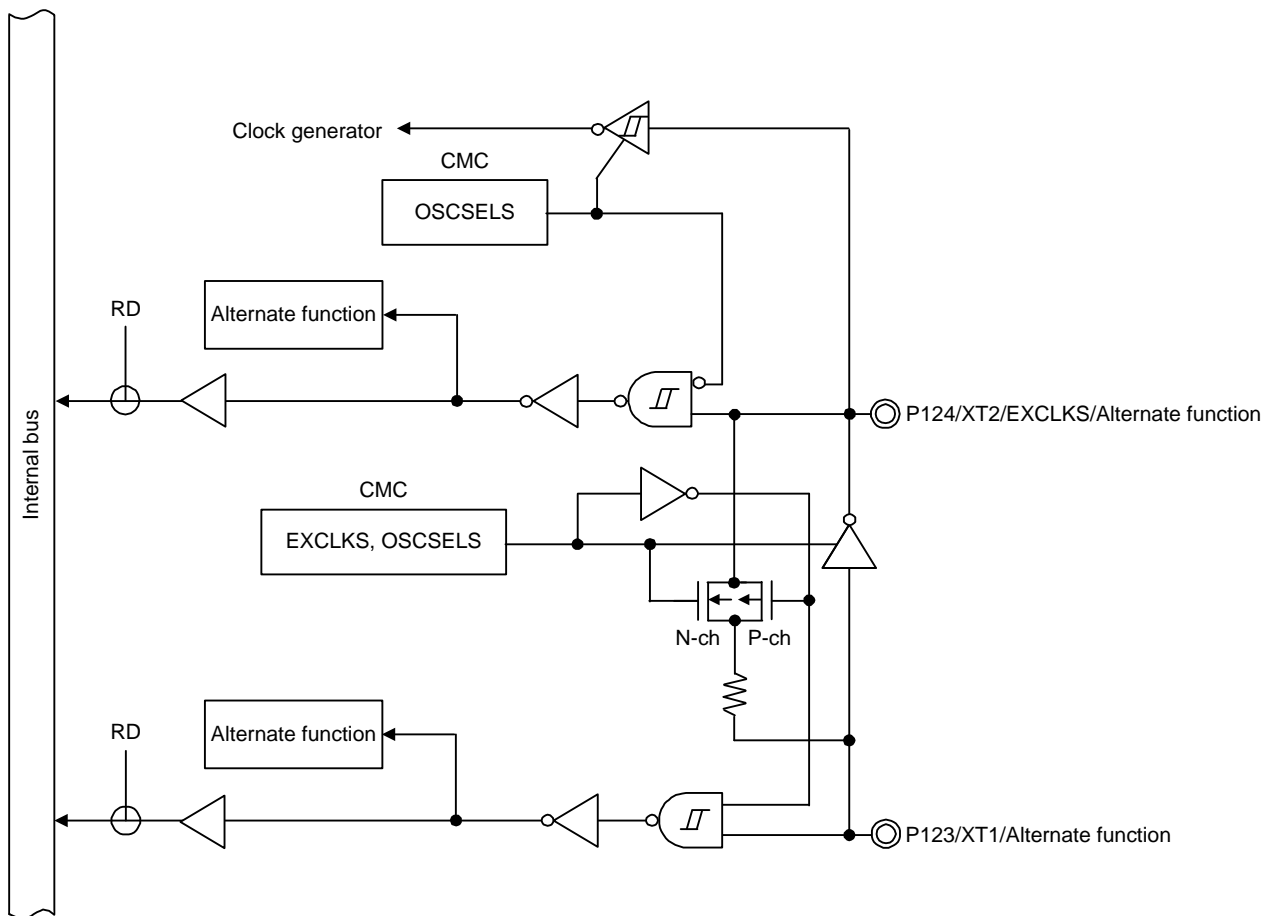

Figure 3-2 Pin Block Diagram for Pin type 2-1-1



Remark Refer to Section 3.2.1 Pin type and alternate function for alternate functions.

Figure 3-3 Pin Block Diagram for Pin type 2-1-2



Remark Refer to Section 3.2.1 Pin type and alternate function for alternate functions.

Figure 3-4 Pin Block Diagram for Pin type 2-2-1

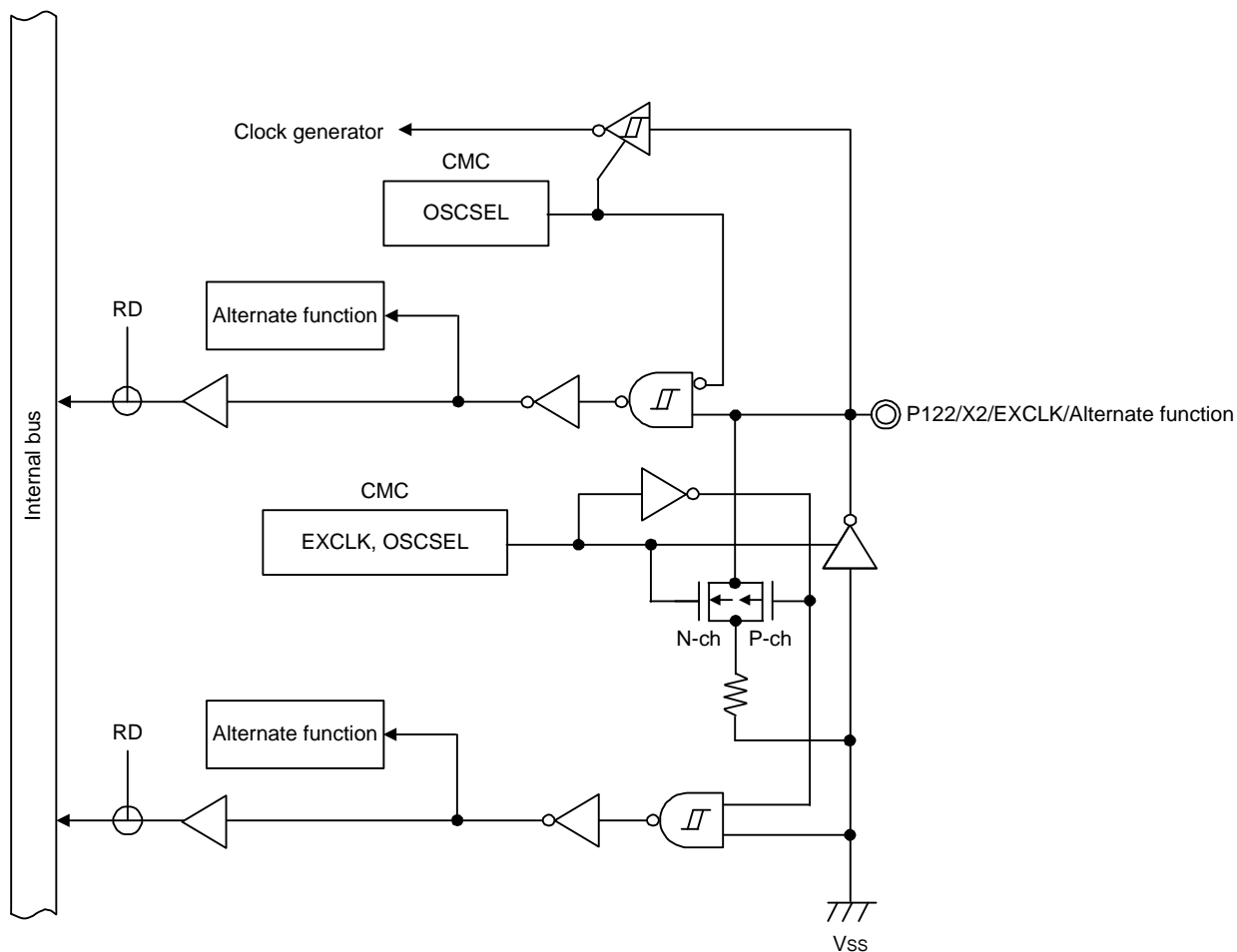

**Remark** Refer to Section 3.2.1 Pin type and alternate function for alternate functions.

**Figure 3-5 Pin Block Diagram for Pin type 2-2-2**

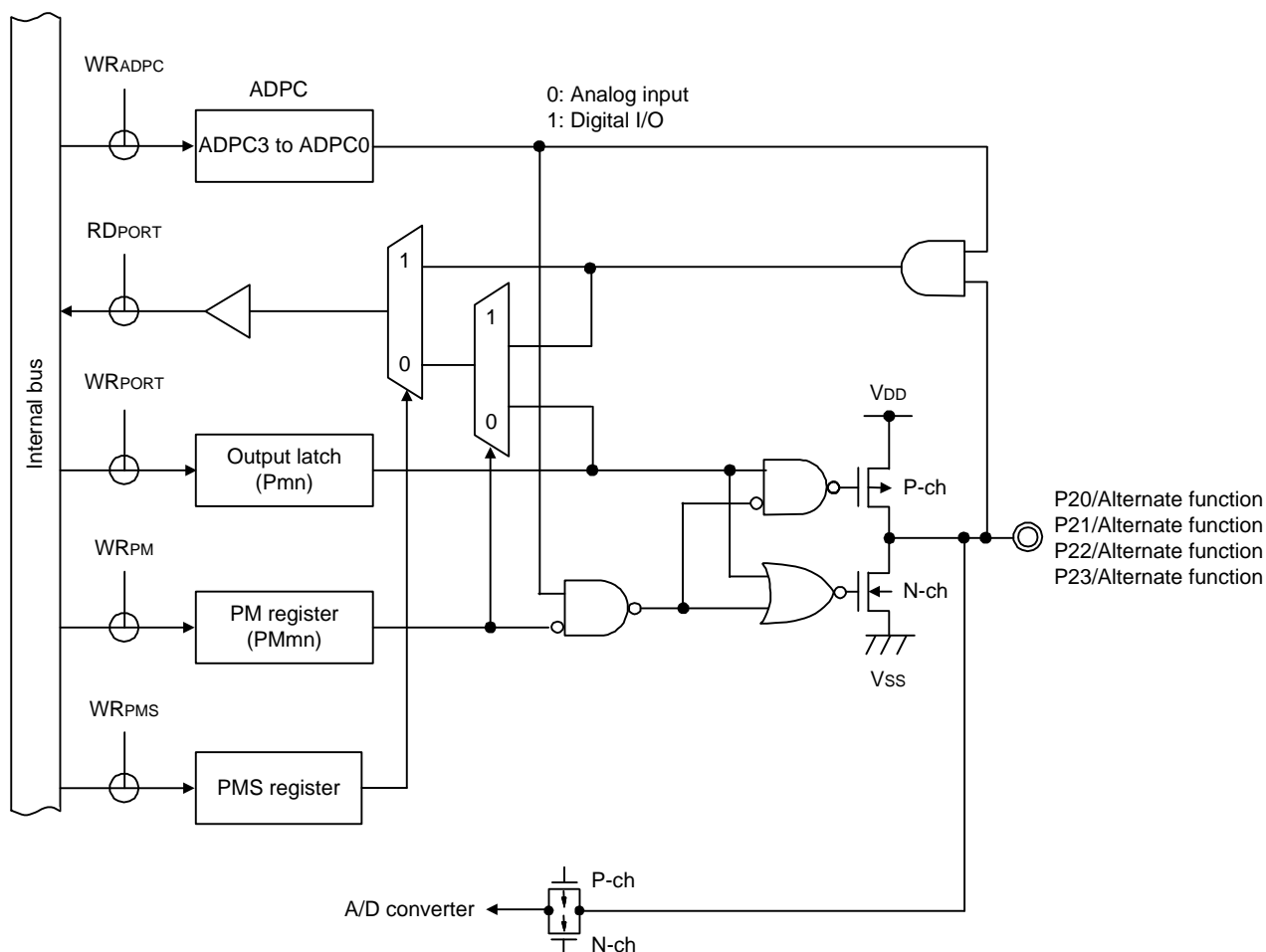

**Remark** Refer to Section 3.2.1 Pin type and alternate function for alternate functions.

**Figure 3-6 Pin Block Diagram for Pin type 4-3-3**



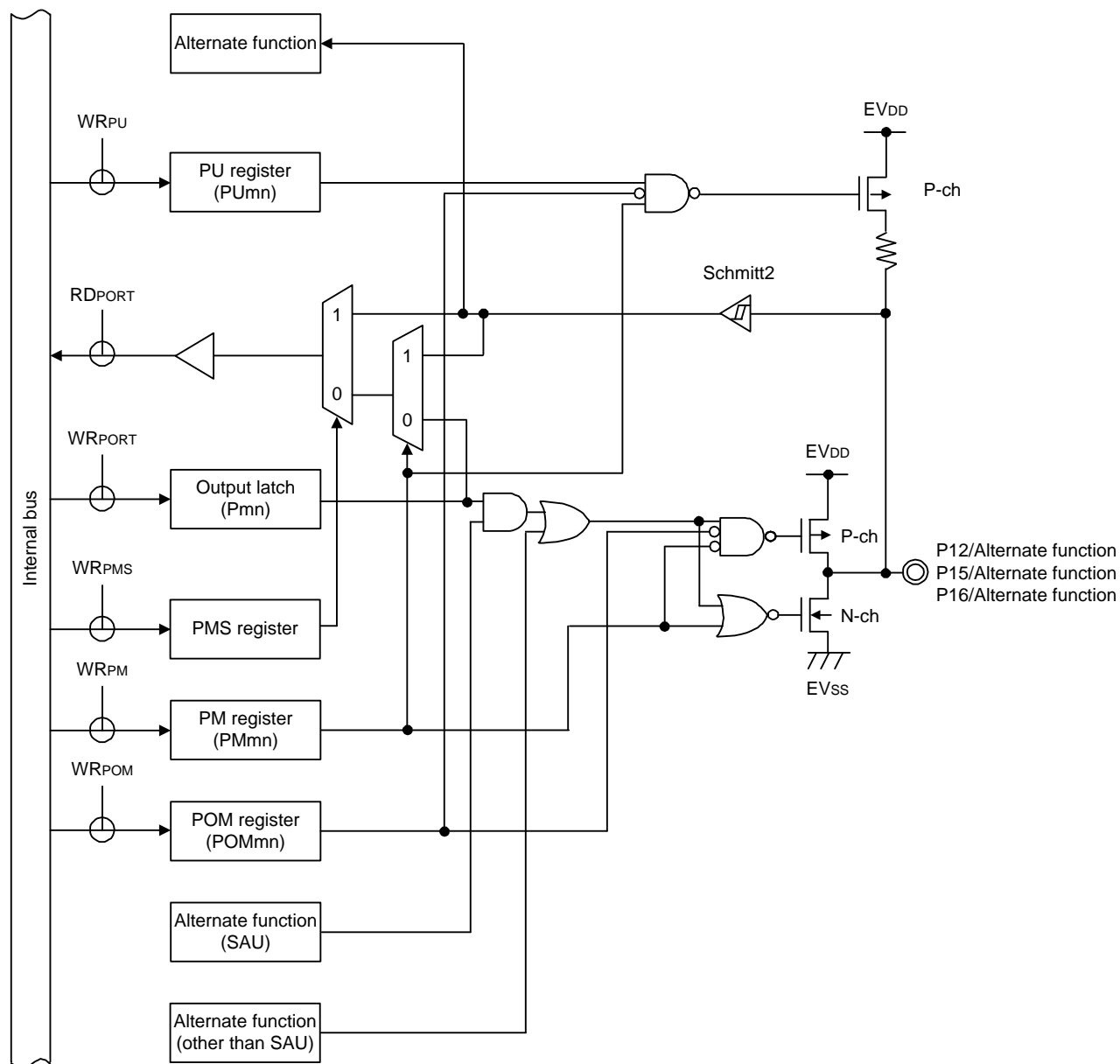

**Remark** Refer to Section 3.2.1 Pin type and alternate function for alternate functions.

**Figure 3-8 Pin Block Diagram for Pin type 7-1-4**

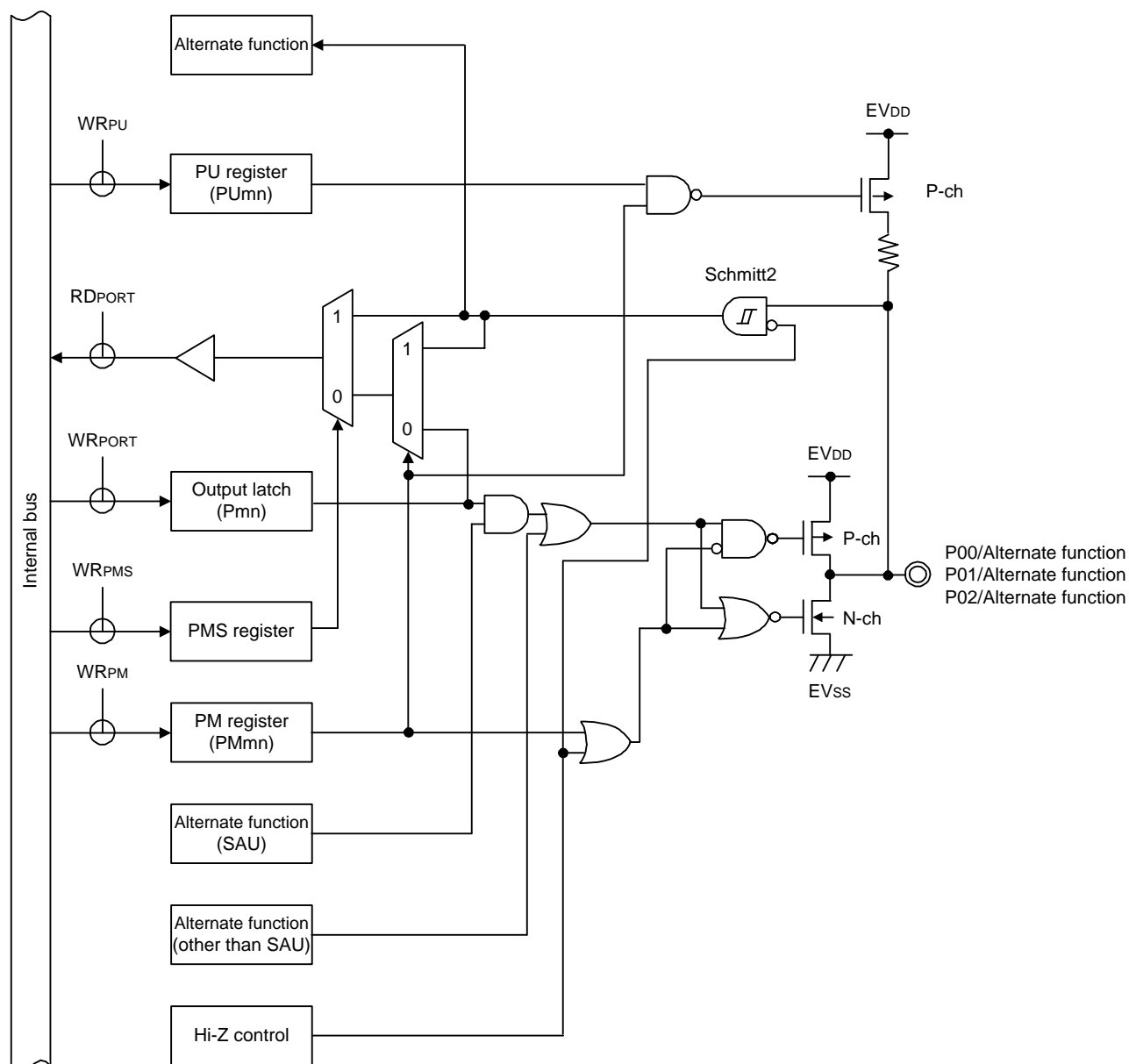

**Remark** Refer to Section 3.2.1 Pin type and alternate function for alternate functions.

**Figure 3-9 Pin Block Diagram for Pin type 7-1-7**

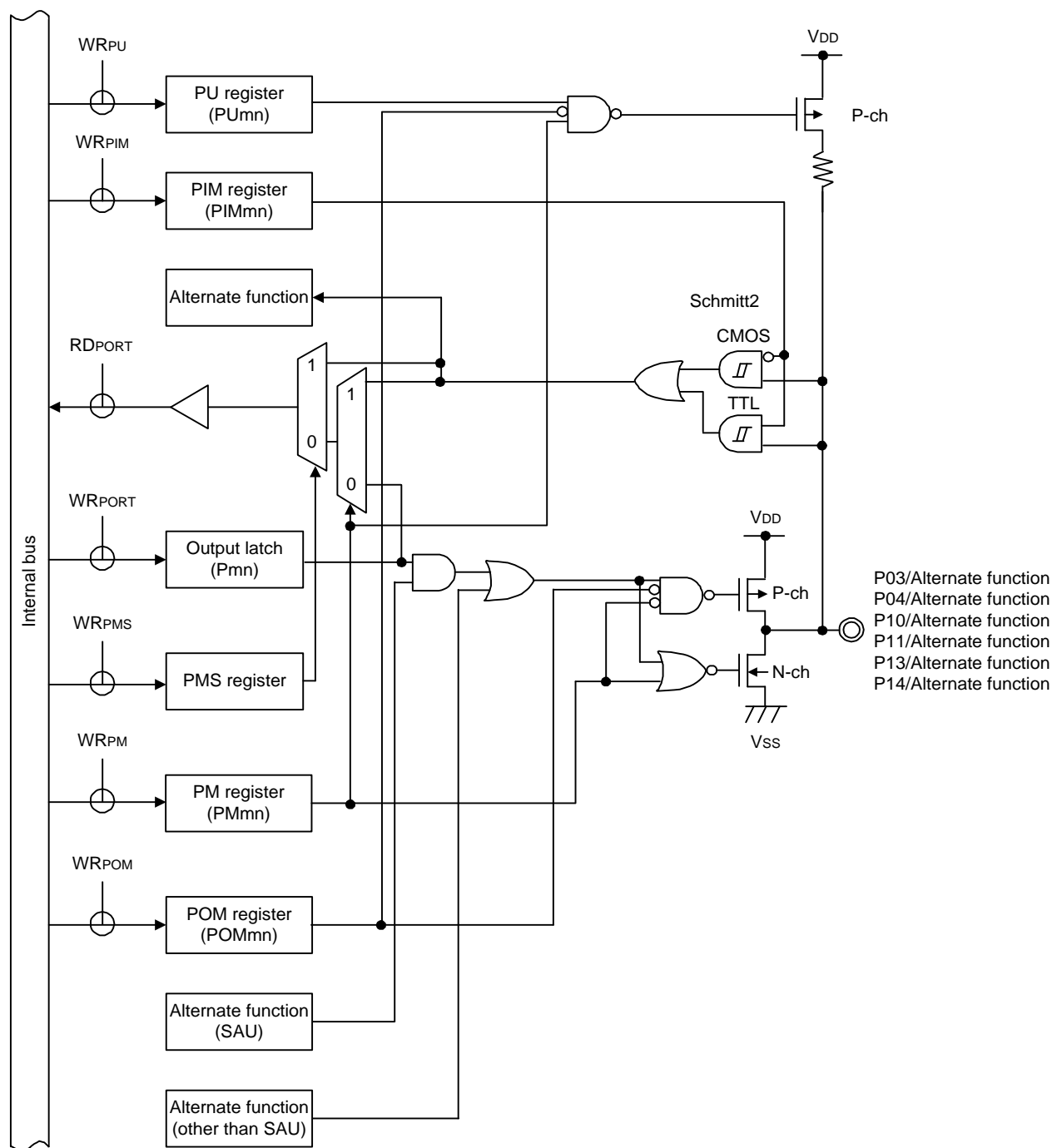

**Remark** Refer to Section 3.2.1 Pin type and alternate function for alternate functions.

**Figure 3-10 Pin Block Diagram for Pin type 8-1-4**

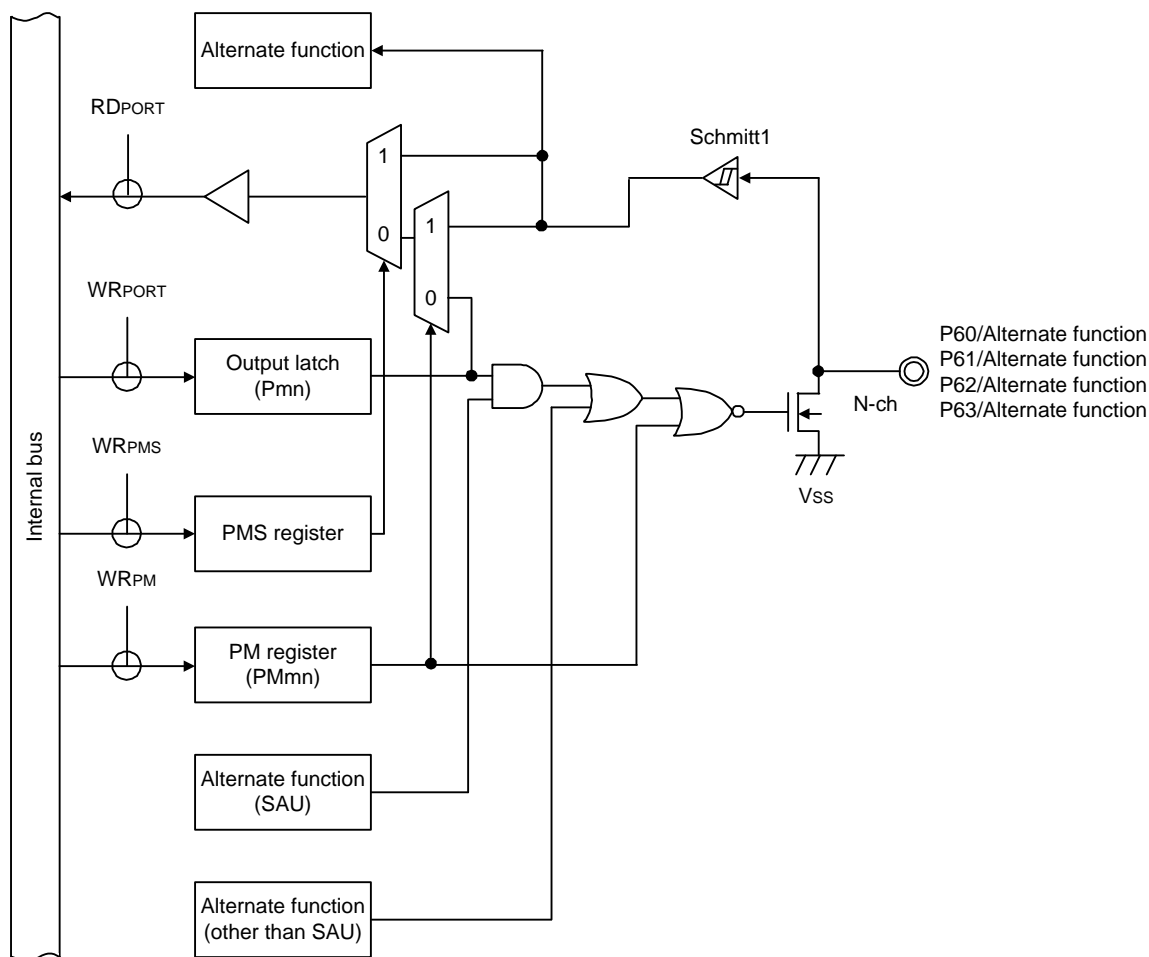

**Remark** Refer to Section 3.2.1 Pin type and alternate function for alternate functions.

**Figure 3-11 Pin Block Diagram for Pin type 12-1-2**

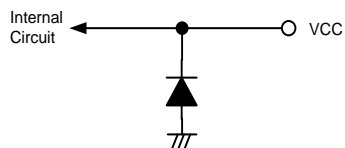

**Figure 3-12 Pin Block Diagram for VCC Pin**

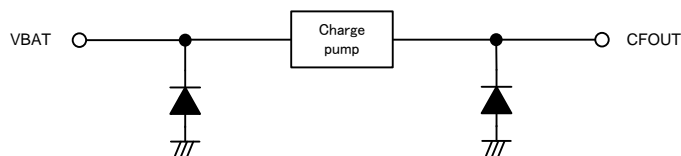

**Figure 3-13 Pin Block Diagram for VBAT and CFOUT Pin**

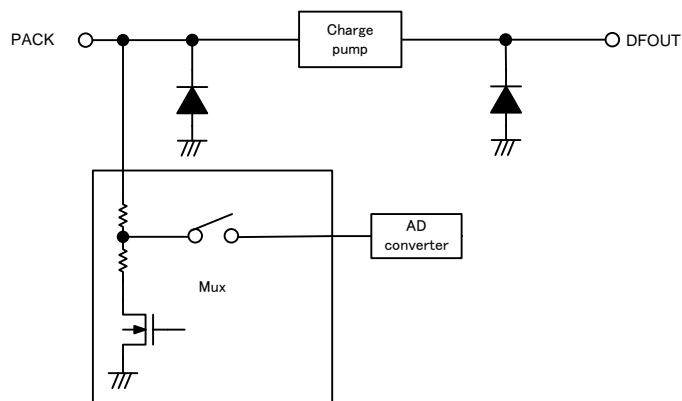

Figure 3-14 Pin Block Diagram for PACK and DFOUT Pin

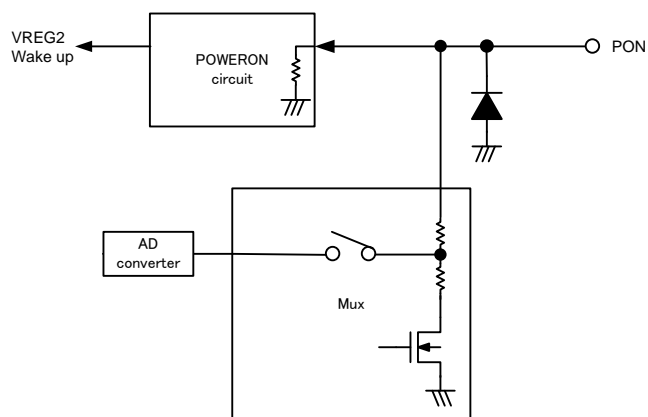
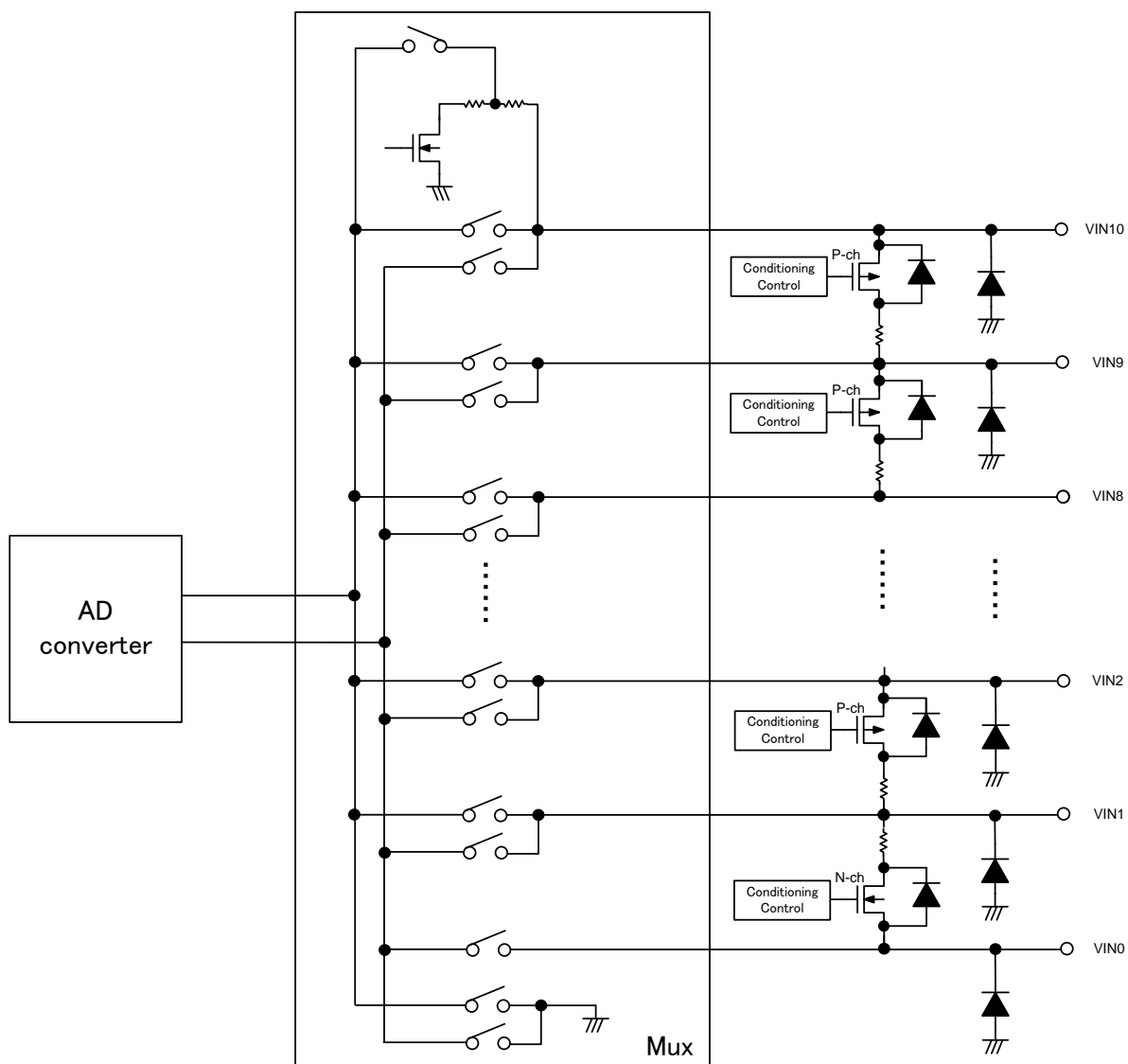

Figure 3-15 Pin Block Diagram for PON Pin



- Caution 1. VIN10 pin and VIN9 pin are only applicable to RAJ240100.
- Caution 2. For RAJ240090, VIN8 pin is connected to ladder resistors.

Figure 3-16 Pin Block Diagram for VIN10 to VIN0 Pin

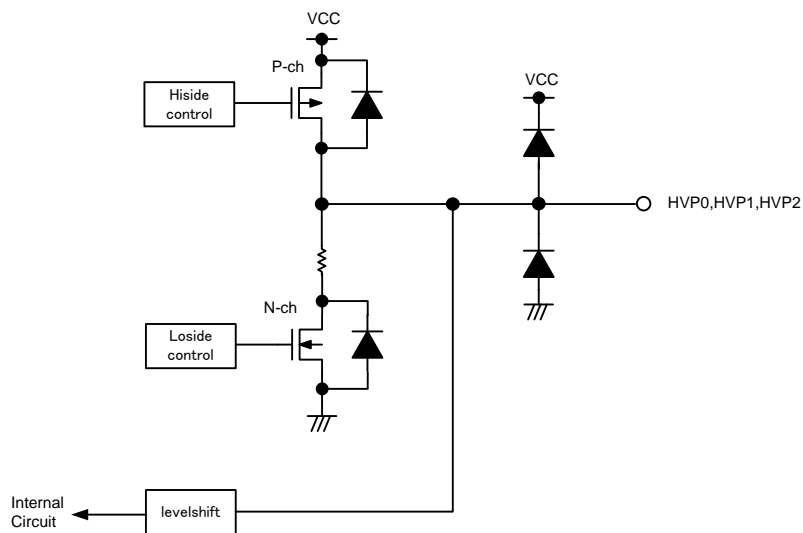

Figure 3-17 Pin Block Diagram for HVP0, HVP1 and HVP2 Pin

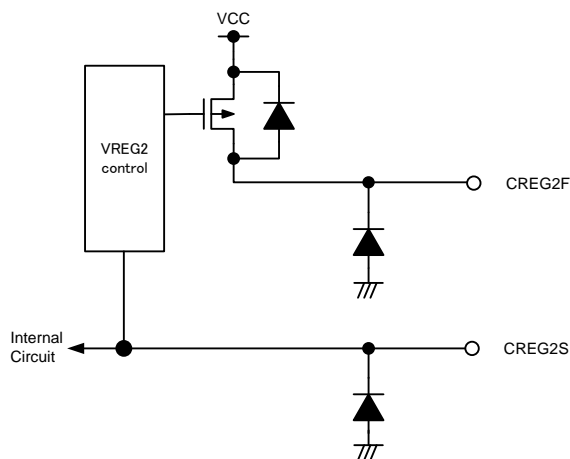

Figure 3-18 Pin Block Diagram for CREG2F and CREG2S Pin

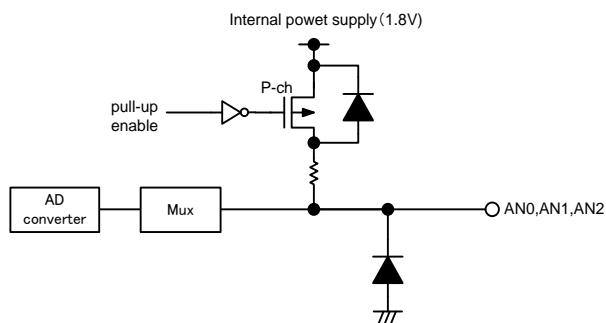

Figure 3-19 Pin Block Diagram for AN0, AN1 and AN2 Pin

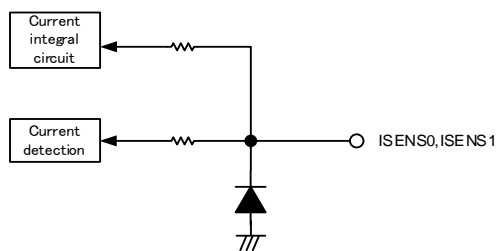

Figure 3-20 Pin Block Diagram for ISENS0 and ISENS1 Pin

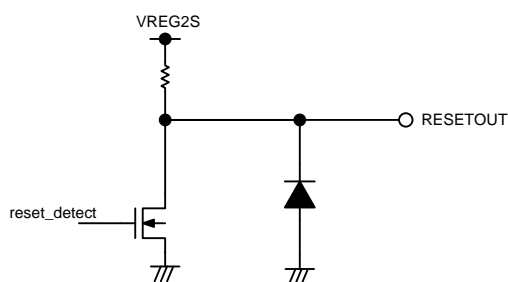

Figure 3-21 Pin Block Diagram for RESETOUT Pin

## 4. ELECTRICAL SPECIFICATIONS

**Caution** This product has an on-chip debug function, which is provided for development and evaluation. Do not use the on-chip debug function in products designated for mass production because the guaranteed number of rewritable times of the flash memory may be exceeded when this function is used, and product reliability therefore cannot be guaranteed. Renesas Electronics is not liable for problems occurring when the on-chip debug function is used.

**Remark 1.** Specifications for VIN10 pin and VIN9 pin are only applicable to RAJ240100.

**Remark 2.** Operating ambient temperature is configurable by REG2T6 bit of REG2T register setting.

In case of setting REG2T6 bit of REG2T register to "0", this device is available in range of TA= -20 to 85°C.

In case of setting REG2T6 bit of REG2T register to "1", this device is available in range of TA= -40 to 85°C.

However, even if REG2T6 bit of REG2T register set to "1", the electrical characteristics which is guaranteed in range of TA = -20 to 85°C is not changed.

### 4.1 Absolute Maximum Ratings

Parameter	Symbols	Conditions	Ratings	Unit	
Supply voltage	V <sub>CC</sub>	V <sub>CC</sub>	-0.5 to +60.0	V	
	V <sub>DD</sub>	V <sub>DD</sub>	-0.5 to +6.5	V	
	GND	GND0, GND1, V <sub>SS</sub>	-0.5 to 0.3	V	
CREG2 pin input voltage	V <sub>CREG2</sub>	CREG2F	-0.5 to +60.0	V	
		CREG2S	-0.3 to 6.5 <sup>Note 2</sup>	V	
REGC pin input voltage	V <sub>IREGC</sub>	REGC	-0.3 to 2.8 and -0.3 to (V <sub>DD</sub> +0.3) <sup>Note 1</sup>	V	
Input voltage	V <sub>I1</sub>	P00 to P07, P10 to P16, P20 to 23, P40 (TOOL0), P122 to P124, P137, RESET	-0.3 to (V <sub>DD</sub> +0.3) <sup>Note 3</sup>	V	
	V <sub>I2</sub>	P60 to P63(N-ch open-drain)	-0.3 to +6.5	V	
	V <sub>IN-H1</sub>	VIN10, VIN9, VIN8, VIN7, VIN6, VIN5, VIN4, VIN3, VIN2, VIN1, VBAT, PACK, PON,	-0.5 to +60.0	V	
	V <sub>IN-H2</sub>	HVP0, HVP1, HVP2	-0.5 to (V <sub>CC</sub> +0.3) <sup>Note 5</sup>	V	
	V <sub>IN-B</sub>	VIN10 to VIN9, VIN9 to VIN8, VIN8 to VIN7, VIN7 to VIN6, VIN6 to VIN5, VIN5 to VIN4, VIN4 to VIN3, VIN3 to VIN2, VIN2 to VIN1, VIN1 to VIN0	-0.5 to +6.5	V	
	V <sub>IN-M</sub>	VIN0	-0.5 to +5.0	V	
	V <sub>IN-L</sub>	AN0, AN1, AN2, ISENS0, ISENS1	-0.5 to +2.0	V	
	V <sub>AI</sub>	ANI00 to ANI03	-0.3 to V <sub>DD</sub> +0.3 and -0.3 to AVREF(+) +0.3 <sup>Notes 3, 4</sup>	V	
Output voltage	V <sub>O1</sub>	P00 to P07, P10 to P16, P20 to 23, P40 (TOOL0), P123, P124, RESETOUT	-0.3 to (V <sub>DD</sub> +0.3) <sup>Note 3</sup>	V	
	V <sub>O-H</sub>	CFOUT, DFOUT, HVP0, HVP1, HVP2	-0.5 to +60.0	V	
High-level output current	I <sub>OH1</sub>	Per pin	P00 to P07, P10 to P16, P40 (TOOL0)	-40	mA
		Total of all pins	P00 to P07, P10 to P16, P40 (TOOL0)	-70	mA
	I <sub>OH2</sub>	Per pin	P20 to P23	-0.5	mA
		Total of all pins	P20 to P23	-2.0	mA
Low-level output current	I <sub>OL1</sub>	Per pin	P00 to P07, P10 to P16, P40 (TOOL0)	+40	mA
		Total of all pins	P00 to P07, P10 to P16, P40 (TOOL0), P60 to P63	+70	mA
Power consumption	P <sub>d</sub>	T <sub>opr</sub> = 25°C	300	mW	
Operating ambient Temperature	T <sub>A</sub>	REG2T6 bit = 0	-20 to +85	°C	
	T <sub>AL</sub>	REG2T6 bit = 1	-40 to +85	°C	
Storage temperature	T <sub>stg</sub>	-	-65 to +150	°C	

(Note, Caution and Remark are listed on next page.)

- Note 1.** Connect the REGC pin to VSS via a capacitor (0.47 to 1 uF). This value regulates the absolute maximum rating of the REGC pin. Do not use this pin with voltage applied to it.
- Note 2.** Connect the CREG2 pin to GND0 or GND1 via a capacitor (1 to 4.7 uF). This value regulates the absolute maximum rating of the CREG2 pin.
- Note 3.** Must be 6.5 V or lower.
- Note 4.** Do not exceed AVREF (+) + 0.3 V in case of A/D conversion target pin.
- Note 5.** Must be 60 V or lower.
- Caution** **Product quality may degrade if the absolute maximum rating has been exceeded. The absolute maximum ratings are rated values where the product is on the verge of suffering physical damage, therefore the product must be used within conditions that ensure the absolute maximum ratings are not exceeded.**

**Remark 1.** Unless specified otherwise, the characteristics of alternate-function pins are the same as those of the port pins.

**Remark 2.** AVREF (+): + side reference voltage of the A/D converter.

**Remark 3.** GND (GND0, GND1 and VSS): Reference voltage.

## 4.2 Power supply voltage condition

Parameter	Symbol	Conditions	MIN.	TYP.	MAX.	Unit
Power supply	VCC, VBAT		4.0	-	50.0	V
	VDD		2.7	-	5.5	V
	GND	GND0, GND1, VSS	-	0.0	-	V

## 4.3 Supply current characteristics

( $T_A = -40/-20$  to  $+85^\circ\text{C}$ ,  $4.0\text{ V} \leq V_{CC} \leq 50\text{ V}$ ,  $V_{DD} = \text{CREG2}$ ,  $\text{GND0} = \text{GND1} = 0\text{ V}$ )

Parameter	Symbol	Conditions	MIN.	TYP.	MAX.	Unit
Power down mode current 1	IPD	VCC = 35 V			2.0	uA
Power down mode current 2 (Low voltage)	IPDL	VCC = 4.0 V			1.0	uA
Sleep mode current 1	ISLP1	$-20^\circ\text{C} \leq T_A \leq 85^\circ\text{C}$ , REG2T6 bit = 0, MCU operation mode: STOP mode ALOCO = ON, AOCO = OFF CD = ALL ON, AFE Timer = ON, AFE WDT = ON, CFOUT = L, DFOUT = L, AD(AFE) = OFF, CC = OFF		25.0	50.0	uA
	ISLP1L	$-40^\circ\text{C} \leq T_A \leq 85^\circ\text{C}$ , REG2T6 bit = 1, MCU operation mode: STOP mode ALOCO = ON, AOCO = OFF CD = ALL ON, AFE Timer = ON, AFE WDT = ON, CFOUT = L, DFOUT = L, AD(AFE) = OFF, CC = OFF		35	70.0	uA
Sleep mode current 2	ISLP2	$-20^\circ\text{C} \leq T_A \leq 85^\circ\text{C}$ , REG2T6 bit = 0, MCU operation mode: STOP mode ALOCO = ON, AOCO = OFF CD = ALL ON, AFE timer = ON, AFE WDT = ON, CFOUT = H, DFOUT = H, AD(AFE) = OFF, CC = OFF		50.0	100.0	uA
	ISLP2L	$-40^\circ\text{C} \leq T_A \leq 85^\circ\text{C}$ , REG2T6 bit = 1, MCU operation mode: STOP mode ALOCO = ON, AOCO = OFF CD = ALL ON, AFE timer = ON, AFE WDT = ON, CFOUT = H, DFOUT = H, AD(AFE) = OFF, CC = OFF		60	120.0	uA
Normal mode current	INOM	MCU operation mode: LS (Low-Speed main) mode, fHOCO=8MHz ALOCO = ON, AOCO = ON CD = ALL ON, AFE Timer = ON, AFE WDT = ON, CFOUT = H, DFOUT = H, AD(AFE) = ON, CC = ON		2.0	3.0	mA

**Note.** "Sleep mode current 1" is the current consumption when PCON register value is set to "63H".

"Sleep mode current 2" is the current consumption when PCON register value is set to "43H".

For details, see 17.18 Power Control function in RAJ240090 / RAJ240100 User's Manual.

**Caution** After trimming.

## 4.4 Oscillator Characteristics

### 4.4.1 XT1 Characteristics

( $T_A = -40/-20$  to  $+85^\circ\text{C}$ ,  $2.7\text{ V} \leq \text{VDD} \leq 5.5\text{ V}$ ,  $\text{GND0} = \text{GND1} = \text{VSS} = 0\text{ V}$ )

Parameter	Resonator	Conditions	MIN.	TYP.	MAX.	Unit
XT1 clock oscillation frequency ( $f_{XT}$ ) <sup>Note</sup>	Crystal resonator		32	32.768	35	kHz

**Note** Indicates only permissible oscillator frequency ranges. Refer to AC Characteristics for instruction execution time. Request evaluation by the manufacturer of the oscillator circuit mounted on a board to check the oscillator characteristics.

### 4.4.2 MCU On-chip oscillator characteristics

( $T_A = -40/-20$  to  $+85^\circ\text{C}$ ,  $2.7\text{ V} \leq \text{VDD} \leq 5.5\text{ V}$ ,  $\text{GND0} = \text{GND1} = \text{VSS} = 0\text{ V}$ )

Parameter	Symbol	Conditions	MIN.	TYP.	MAX.	Unit
High-speed on-chip oscillator clock frequency <sup>Note 1, 2</sup>	$f_{IH}$		1		32	MHz
High-speed on-chip oscillator clock frequency accuracy		$-20^\circ\text{C} \leq T_A \leq 85^\circ\text{C}$	-1.0		+1.0	%
		$-40^\circ\text{C} \leq T_A \leq 85^\circ\text{C}$	-1.5		+1.5	%
Low-speed on-chip oscillator clock frequency	$f_{IL}$			15		kHz
Low-speed on-chip oscillator clock frequency accuracy			-15		+15	%

**Note 1.** High-speed on-chip oscillator frequency is selected with bits 0 to 4 of the option byte (000C2H) and bits 0 to 2 of the HOCODIV register.

**Note 2.** This only indicates the oscillator characteristics. Refer to AC Characteristics for instruction execution time.

### 4.4.3 AFE On-chip oscillator characteristics

( $T_A = -40/-20$  to  $+85^\circ\text{C}$ ,  $4.0\text{ V} \leq \text{VCC} \leq 50\text{ V}$ ,  $\text{GND0} = \text{GND1} = \text{VSS} = 0\text{ V}$ )

Parameter	Symbol	Conditions	MIN.	TYP.	MAX.	Unit
AFE on-chip oscillator clock frequency	$f_{AOCO}$		-	4.194	-	MHz
AFE on-chip oscillator clock frequency accuracy			-2	-	+2	%
AFE on-chip oscillator clock frequency stabilization wait time			-	-	(50)	us
AFE Low-speed on-chip oscillator clock frequency	$f_{ALOCO}$		-	131.072	-	kHz
AFE Low-speed on-chip oscillator clock frequency accuracy			-5	-	+5	%
AFE Low-speed on-chip oscillator clock frequency stabilization wait time			-	-	(50)	us

**Caution** After trimming.

**Remark** Values in brackets are design value.

## 4.5 Pin characteristics

(1/5)

( $T_A = -40/-20$  to  $+85^\circ\text{C}$ ,  $4.0\text{ V} \leq V_{CC} \leq 5.0\text{ V}$ ,  $2.7\text{ V} \leq V_{DD} \leq 5.5\text{ V}$ ,  $GND0 = GND1 = VSS = 0\text{ V}$ )

Parameter	Symbol	Conditions	MIN.	TYP.	MAX.	Unit	
Output current, high <sup>Note 1</sup>	IOH1	Per pin for P00 to P07, P10 to P16, P40			-10.0 <sup>Note 2</sup>	mA	
		Total of P00 to P07, P10 to P16, P40 (When duty $\leq 70\%$ <sup>Note 3</sup> )	$4.0\text{ V} \leq V_{DD} \leq 5.5\text{ V}$		-55.0	mA	
			$2.7\text{ V} \leq V_{DD} < 4.0\text{ V}$		-10.0	mA	
	Total of all pins (When duty $\leq 70\%$ <sup>Note 3</sup> )	$2.7\text{ V} \leq V_{DD} \leq 5.5\text{ V}$			-100.0	mA	
	IOH2	Per pin for P20 to P23	$2.7\text{ V} \leq V_{DD} \leq 5.5\text{ V}$			-0.1 <sup>Note 2</sup>	mA
		Total of all pins (When duty $\leq 70\%$ <sup>Note 3</sup> )	$2.7\text{ V} \leq V_{DD} \leq 5.5\text{ V}$			-1.5	mA

**Note 1.** Value of current at which the device operation is guaranteed even if the current flows from the VDD pins to an output pin.

**Note 2.** Do not exceed the total current value.

**Note 3.** Specification under conditions where duty factor  $\leq 70\%$ .

The output current value that has changed to the duty factor  $> 70\%$  the duty ratio can be calculated with the following expression (when changing the duty factor from  $70\%$  to  $n\%$ ).

- Total output current from pins =  $(I_{OH} \times 0.7)/(n \times 0.01)$

<Example> Where  $n = 80\%$  and  $I_{OH} = -10.0\text{ mA}$

$$\text{Total output current from pins} = (-10.0 \times 0.7)/(80 \times 0.01) \approx -8.7\text{ mA}$$

However, the allowable current flow into one pin does not change with the duty factor.

A current higher than the absolute maximum rating must not flow into any one pin.

**Caution** P03, P04, and P10 to P16 do not output high level in N-ch open-drain mode.

**Remark** Unless specified otherwise, the characteristics of alternate-function pins are the same as those of the port pins.

(T<sub>A</sub> = -40/-20 to +85°C, 4.0 V ≤ VCC ≤ 50 V, 2.7 V ≤ VDD ≤ 5.5 V, GND0 = GND1 = VSS = 0 V)

Parameter	Symbol	Conditions	MIN.	TYP.	MAX.	Unit	
Output current, low <sup>Note 1</sup>	IOL1	Per pin for P00 to P07, P10 to P16, P40			20.0 <small>Note 2</small>	mA	
		Per pin for P60-P63			15.0 <small>Note 2</small>	mA	
		Total of P00 to P07, P10 to P16, P40 (When duty ≤ 70 % <sup>Note 3</sup> )	4.0 V ≤ VDD ≤ 5.5 V			70.0	mA
			2.7 V ≤ VDD < 4.0 V			15.0	mA
	Total of all pins (When duty ≤ 70 % <sup>Note 3</sup> )				150.0	mA	
	IOL2	Per pin for P20 to P23				0.4 <small>Note 2</small>	mA
		Total of all pins (When duty ≤ 70 % <sup>Note 3</sup> )	2.7 V ≤ VDD ≤ 5.5 V			5.0	mA

**Note 1.** Value of current at which the device operation is guaranteed even if the current flows from an output pin to the VSS pins.

**Note 2.** Do not exceed the total current value.

**Note 3.** Specification under conditions where the duty factor ≤ 70 %.

The output current value that has changed to the duty factor > 70 % the duty ratio can be calculated with the following expression (when changing the duty factor from 70 % to n %).

$$\bullet \text{ Total output current of pins} = (IOL \times 0.7)/(n \times 0.01)$$

<Example> Where n = 80 % and IOL = 10.0 mA

$$\text{Total output current of pins} = (10.0 \times 0.7)/(80 \times 0.01) \approx 8.7 \text{ mA}$$

However, the allowable current flow into one pin does not change with the duty factor.

A current higher than the absolute maximum rating must not flow into any one pin.

**Remark** Unless specified otherwise, the characteristics of alternate-function pins are the same as those of the port pins.

(T<sub>A</sub> = -40/-20 to +85°C, 4.0 V ≤ VCC ≤ 50 V, 2.7 V ≤ VDD ≤ 5.5 V, GND0 = GND1 = VSS = 0 V)

Parameter	Symbol	Conditions	MIN.	TYP.	MAX.	Unit	
Input voltage, high	V <sub>IH1</sub>	P00 to P02, P05 to P07, P10 to P16, P40	Normal input buffer	0.8 VDD		VDD	V
	V <sub>IH2</sub>	P03, P04, P10, P11, P13, P14	TTL input buffer 4.0 V ≤ VDD ≤ 5.5 V	2.2		VDD	V
			TTL input buffer 3.3 V ≤ VDD < 4.0 V	2.0		VDD	V
			TTL input buffer 2.7 V ≤ VDD < 3.3 V	1.5		VDD	V
	V <sub>IH3</sub>	P20 to P23		0.7 VDD		VDD	V
	V <sub>IH4</sub>	P60 to P63		0.7 VDD		6.0	V
	V <sub>IH5</sub>	P122 to P124, P137, RESET		0.8 VDD		VDD	V
	V <sub>IH6</sub>	P03, P04		0.8 VDD		VDD	V
Input voltage, low	V <sub>IL1</sub>	P00 to P02, P05 to P07, P10 to P16, P40	Normal input buffer	0		0.2 VDD	V
	V <sub>IL2</sub>	P03, P04, P10, P11, P13, P14	TTL input buffer 4.0 V ≤ VDD ≤ 5.5 V	0		0.8	V
			TTL input buffer 3.3 V ≤ VDD < 4.0 V	0		0.5	V
			TTL input buffer 2.7 V ≤ VDD < 3.3 V	0		0.32	V
	V <sub>IL3</sub>	P20 to P23		0		0.3 VDD	V
	V <sub>IL4</sub>	P60 to P63		0		0.3 VDD	V
	V <sub>IL5</sub>	P122 to P124, P137, RESET		0		0.2 VDD	V
	V <sub>IL6</sub>	P03, P04	3.0 V ≤ VDD ≤ 5.5 V	0		0.5 VDD	V
2.7 V ≤ VDD < 3.0 V			0		0.4 VDD	V	

**Caution** The maximum value of V<sub>IH</sub> of pins P03, P04, P10 to P16 is VDD, even in the N-ch open-drain mode.**Remark** Unless specified otherwise, the characteristics of alternate-function pins are the same as those of the port pins.

(4/5)

(T<sub>A</sub> = -40/-20 to +85°C, 4.0 V ≤ VCC ≤ 5.0 V, 2.7 V ≤ VDD ≤ 5.5 V, GND0 = GND1 = VSS = 0 V)

Parameter	Symbol	Conditions	MIN.	TYP.	MAX.	Unit
Output voltage, high	V <sub>OH1</sub>	P00 to P07, P10 to P16, P40	4.0 V ≤ VDD ≤ 5.5 V, IOH1 = -10.0 mA	VDD - 1.5		V
			4.0 V ≤ VDD ≤ 5.5 V, IOH1 = -3.0 mA	VDD - 0.7		V
			2.7 V ≤ VDD ≤ 5.5 V, IOH1 = -1.5 mA	VDD - 0.5		V
	V <sub>OH2</sub>	P20 to P23	2.7 V ≤ VDD ≤ 5.5 V, IOH2 = -100 uA	VDD - 0.5		V
Output voltage, low	V <sub>OL1</sub>	P00 to P07, P10 to P16, P40	4.0 V ≤ VDD ≤ 5.5 V, IOL1 = 20.0 mA		1.3	V
			4.0 V ≤ VDD ≤ 5.5 V, IOL1 = 8.5 mA		0.7	V
			2.7 V ≤ VDD ≤ 5.5 V, IOL1 = 3.0 mA		0.6	V
			2.7 V ≤ VDD ≤ 5.5 V, IOL1 = 1.5 mA		0.4	V
			2.7 V ≤ VDD ≤ 5.5 V, IOL1 = 0.6 mA		0.4	V
			2.7 V ≤ VDD ≤ 5.5 V, IOL1 = 0.3 mA		0.4	V
			2.7 V ≤ VDD ≤ 5.5 V, IOL1 = 0.3 mA		0.4	V
	V <sub>OL2</sub>	P20 to P23	1.6 V ≤ VDD ≤ 5.5 V, IOL2 = 400 uA		0.4	V
	V <sub>OL3</sub>	P60 to P63	4.0 V ≤ VDD ≤ 5.5 V, IOL3 = 15.0 mA		2.0	V
			4.0 V ≤ VDD ≤ 5.5 V, IOL3 = 5.0 mA		0.4	V
			2.7 V ≤ VDD ≤ 5.5 V, IOL3 = 3.0 mA		0.4	V
			1.8 V ≤ VDD ≤ 5.5 V, IOL3 = 2.0 mA		0.4	V
			1.6 V ≤ VDD ≤ 5.5 V, IOL3 = 1.0 mA		0.4	V

**Caution** P03, P04, P10 to P16 do not output high level in N-ch open-drain mode.

**Remark** Unless specified otherwise, the characteristics of alternate-function pins are the same as those of the port pins.

(T<sub>A</sub> = -40/-20 to +85°C, 4.0 V ≤ VCC ≤ 50 V, 2.7 V ≤ VDD ≤ 5.5 V, GND0 = GND1 = VSS = 0 V)

Parameter	Symbol	Conditions		MIN.	TYP.	MAX.	Unit	
Input leakage current, high	ILIH1	P00 to P07, P10 to P16, P40	VI = VDD			1	uA	
	ILIH2	P20 to P23, P137, RESET	VI = VDD			1	uA	
	ILIH3	P122 to P124	VI = VDD	In input port or external clock input			1	uA
				In resonator connection			10	uA
Input leakage current, low	ILIL1	P00 to P07, P10 to P16, P40	VI = VSS			-1	uA	
	ILIL2	P20 to P23, P137, RESET	VI = VSS			-1	uA	
	ILIL3	P122 to P124	VI = VSS	In input port or external clock input			-1	uA
				In resonator connection			-10	uA
On-chip pull-up resistance	RU	P00 to P07, P10 to P16, P40	VI = VSS, In input port	10	20	100	kΩ	
	RUA	AN0, AN1, AN2		7.5	10	12.5	kΩ	
	RUAR	RESETOUT			20		kΩ	

**Remark 1.** Unless specified, the characteristics of alternate-function pins are the same as those of the port pins.

**Remark 2.** Regarding pin characteristics of CFOUT, DFOUT, refer to Section 4.8.6 Charge/discharge FET control circuit characteristics.

**Remark 3.** Regarding pin characteristics of VIN1 to VIN10 refer to Section 4.8.2 Multiplexer.

**Remark 4.** Regarding pin characteristics of HVP0 to HVP2 refer to Section 4.8.1 High-voltage port characteristics.

## 4.6 AC Characteristics

(1/2)

( $T_A = -40/-20$  to  $+85^\circ\text{C}$ ,  $2.7\text{ V} \leq V_{DD} \leq 5.5\text{ V}$ ,  $\text{GND0} = \text{GND1} = \text{VSS} = 0\text{ V}$ )

Parameter	Symbol	Conditions	MIN.	TYP.	MAX.	Unit	
Instruction cycle (minimum instruction execution time)	$T_{CY}$	Main system clock ( $f_{MAIN}$ ) operation	HS (high-speed main) mode	0.03125		1	us
			LS (low-speed main) mode	0.125		1	us
			LV (low-voltage main) mode	0.25		1	us
		Subsystem clock ( $f_{SUB}$ ) operation		28.5	30.5	31.3	us
		In the self-programming mode	HS (high-speed main) mode	0.03125		1	us
			LS (low-speed main) mode	0.125		1	us
LV (low-voltage main) mode	0.25			1	us		
External system clock frequency	$f_{EXS}$		32		35	kHz	
External system clock input high-level width, low-level width	$t_{EXHS}$ , $t_{EXLS}$		13.7			us	
Tl00 to Tl02 input high-level width, low-level width	$t_{TIH}$ , $t_{TIL}$		$1/f_{MCK} + 10$			ns	

**Remark**  $f_{MCK}$ : Timer array unit operation clock frequency

(Operation clock to be set by the CKSmn bit of timer mode register mn (TMRmn). m: Unit number (m = 0, 1),

n: Channel number (n = 0 to 3))

(2/2)

(T<sub>A</sub> = -40/-20 to +85°C, 2.7 V ≤ VDD ≤ 5.5 V, GND0 = GND1 = VSS = 0 V)

Parameter	Symbol	Conditions	MIN.	TYP.	MAX.	Unit
Timer RD input high-level width, low-level width	tTDIH, tTDIL	TRDIOB0, TRDIOC0, TRDIOD0	3/f <sub>CLK</sub>			ns
Timer RD forced cutoff signal input low-level width	tTDSIL	P16/INTP0	2 MHz < f <sub>CLK</sub> ≤ 32 MHz	1		us
			f <sub>CLK</sub> ≤ 2 MHz	1/f <sub>CLK</sub> + 1		
TO00 to TO02, TRDIOB0, TRDIOC0, TRDIOD0 output frequency	f <sub>TO</sub>	HS (high-speed main) mode	4.0 V ≤ VDD ≤ 5.5 V		16	MHz
			2.7 V ≤ VDD < 4.0 V		8	MHz
		LS (low-speed main) mode	2.7 V ≤ VDD ≤ 5.5 V		4	MHz
		LV(low-voltage main) mode	2.7 V ≤ VDD ≤ 5.5 V		2	MHz
Interrupt input high-level width, low-level width	tINTH, tINTL	INTP0 to INTP13	1.6 V ≤ VDD ≤ 5.5 V	1		us
RESET low-level width	trSL			10		us

**AC Timing Test Points**

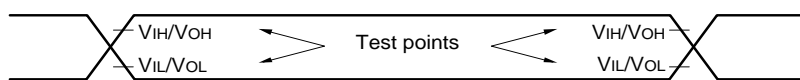

**External System Clock Timing**

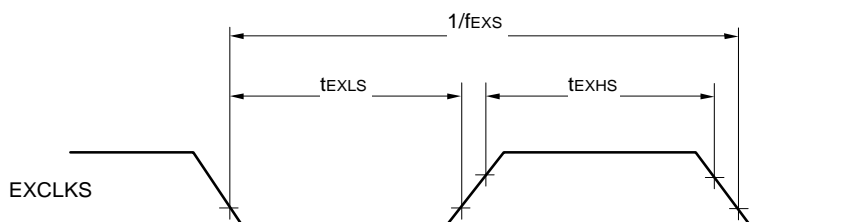

**TI/TO Timing**

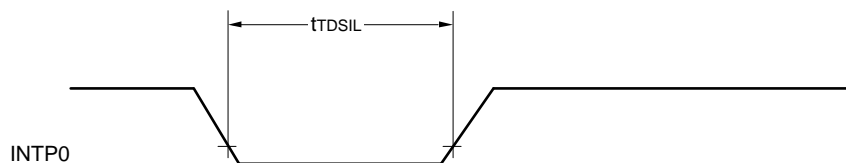
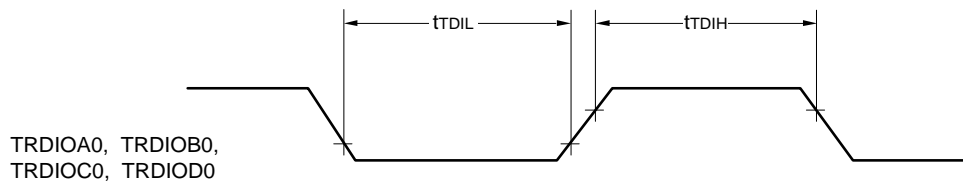
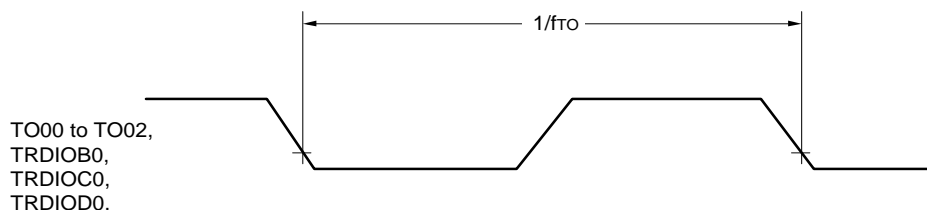
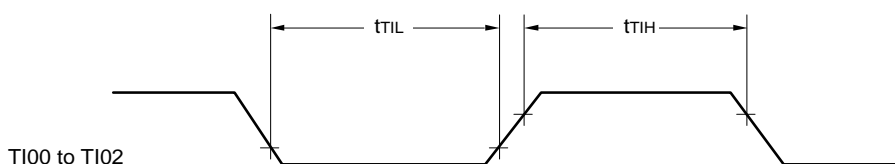

**Interrupt Request Input Timing**

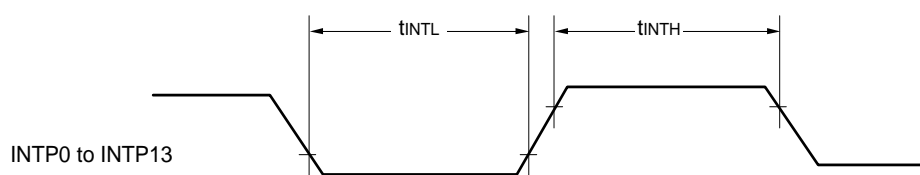

**RESET Input Timing**

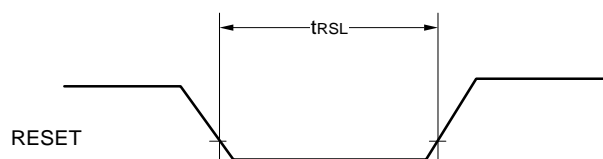

### 4.7 MCU peripheral circuit characteristics

#### AC Timing Test Points

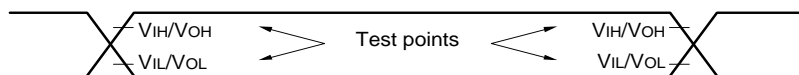

#### 4.7.1 Serial array unit

(1) During communication at same potential (UART mode)

(TA = -40/-20 to +85°C, 2.7 V ≤ VDD ≤ 5.5 V, GND0 = GND1 = VSS = 0 V)

Parameter	Symbol	Conditions	HS (high-speed main) mode		LS (low-speed main) mode		LV (low-voltage main) mode		Unit
			MIN.	MAX.	MIN.	MAX.	MIN.	MAX.	
Transfer rate <small>Note</small>				fMCK/6		fMCK/6		fMCK/6	bps
		Theoretical value of the maximum transfer rate fMCK = fCLK		5.3		1.3		0.6	Mbps

**Note** Transfer rate in the SNOOZE mode is only 4800 bps.

**Caution** Select the normal input buffer for the RxDq pin and the normal output mode for the TxDq pin by using port input mode register g (PIMg) and port output mode register g (POMg).

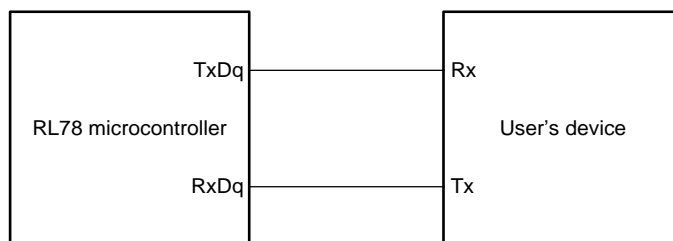

UART mode connection diagram (during communication at same potential)

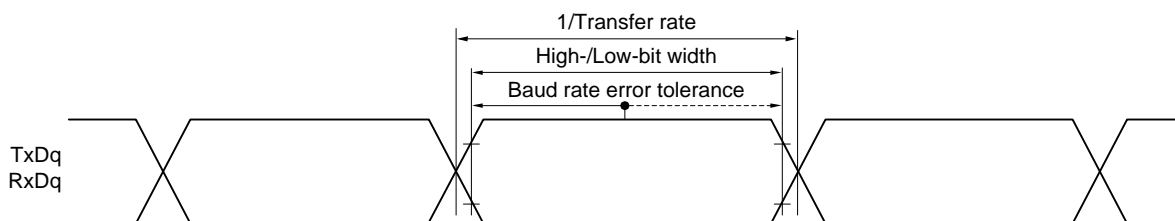

UART mode bit width (during communication at same potential) (reference)

**Remark 1.** q: UART number (q = 0 to 3), g: PIM and POM number (g = 0, 1, 5, 14)

**Remark 2.** fMCK: Serial array unit operation clock frequency

(Operation clock to be set by the CKSmn bit of serial mode register mn (SMRmn). m: Unit number, n: Channel number (mn = 00 to 03, 10 to 13))

(2) During communication at same potential (CSI mode) (master mode, SCKp... internal clock output)

( $T_A = -40/-20$  to  $+85^\circ\text{C}$ ,  $2.7\text{ V} \leq \text{VDD} \leq 5.5\text{ V}$ ,  $\text{GND0} = \text{GND1} = \text{VSS} = 0\text{ V}$ )

Parameter	Symbol	Conditions	HS (high-speed main) mode		LS (low-speed main) mode		LV (low-voltage main) mode		Unit
			MIN.	MAX.	MIN.	MAX.	MIN.	MAX.	
SCKp cycle time	t <sub>KCY1</sub>	t <sub>KCY1</sub> ≥ 4/f <sub>CLK</sub>	125		500		1000		ns
SCKp high-/low-level width	t <sub>KH1</sub> , t <sub>KL1</sub>	4.0 V ≤ VDD ≤ 5.5 V	t <sub>KCY1</sub> /2 - 12		t <sub>KCY1</sub> /2 - 50		t <sub>KCY1</sub> /2 - 50		ns
		2.7 V ≤ VDD ≤ 5.5 V	t <sub>KCY1</sub> /2 - 18		t <sub>KCY1</sub> /2 - 50		t <sub>KCY1</sub> /2 - 50		ns
Slp setup time (to SCKp↑) <sup>Note 1</sup>	t <sub>SIK1</sub>	4.0 V ≤ VDD ≤ 5.5 V	44		110		110		ns
		2.7 V ≤ VDD ≤ 5.5 V	44		110		110		ns
Slp hold time (from SCKp↓) <sup>Note 2</sup>	t <sub>SIH1</sub>		19		19		19		ns
Delay time from SCKp↓ to SOp output <sup>Note 3</sup>	t <sub>KSO1</sub>	C = 30 pF <sup>Note 4</sup>		25		25		25	ns

**Note 1.** When DAPmn = 0 and CKPmn = 0, or DAPmn = 1 and CKPmn = 1.

The Slp setup time becomes "to SCKp↓" when DAPmn = 0 and CKPmn = 1, or DAPmn = 1 and CKPmn = 0.

**Note 2.** When DAPmn = 0 and CKPmn = 0, or DAPmn = 1 and CKPmn = 1.

The Slp hold time becomes "from SCKp↓" when DAPmn = 0 and CKPmn = 1, or DAPmn = 1 and CKPmn = 0.

**Note 3.** When DAPmn = 0 and CKPmn = 0, or DAPmn = 1 and CKPmn = 1.

The delay time to SOp output becomes "from SCKp↑" when DAPmn = 0 and CKPmn = 1, or DAPmn = 1 and CKPmn = 0.

**Note 4.** C is the load capacitance of the SCKp and SOp output lines.

**Caution** Select the normal input buffer for the Slp pin and the normal output mode for the SOp pin and SCKp pin by using port input mode register g (PIMg) and port output mode register g (POMg).

**Remark 1.** p: CSI number (p = 00, 10), m: Unit number (m = 0, 1), n: Channel number (n = 0 to 3),

g: PIM number (g = 0, 1, 3 to 5, 14)

**Remark 2.** f<sub>MCK</sub>: Serial array unit operation clock frequency (Operation clock to be set by the CKSmn bit of serial mode register mn (SMRmn).

m: Unit number, n: Channel number (mn = 00, 02))

(3) During communication at same potential (CSI mode) (slave mode, SCKp... external clock input)

(T<sub>A</sub> = -40/-20 to +85°C, 2.7 V ≤ VDD ≤ 5.5 V, GND0 = GND1 = VSS = 0 V)

Parameter	Symbol	Conditions		HS (high-speed main) mode		LS (low-speed main) mode		LV (low-voltage main) mode		Unit
				MIN.	MAX.	MIN.	MAX.	MIN.	MAX.	
SCKp cycle time <small>Note 5</small>	tkCY2	4.0 V ≤ VDD ≤ 5.5 V	20 MHz < fMCK	8/fMCK		—		—		ns
			fMCK ≤ 20 MHz	6/fMCK		6/fMCK		6/fMCK	ns	
		2.7 V ≤ VDD ≤ 5.5 V	1 MHz < fMCK	8/fMCK		—		—		ns
			fMCK ≤ 16 MHz	6/fMCK		6/fMCK		6/fMCK	ns	
SCKp high-/low-level width	tkH2, tkL2	4.0 V ≤ VDD ≤ 5.5 V		tkCY2/2 - 7		tkCY2/2 - 7		tkCY2/2 - 7		ns
		2.7 V ≤ VDD ≤ 5.5 V		tkCY2/2 - 8		tkCY2/2 - 8		tkCY2/2 - 8		ns
Slp setup time (to SCKp↑) <small>Note 1</small>	tSIK2			1/fMCK + 20		1/fMCK + 30		1/fMCK + 30		ns
Slp hold time (from SCKp↑) <small>Note 2</small>	tKS2			1/fMCK + 31		1/fMCK + 31		1/fMCK + 31		ns
Delay time from SCKp↓ to SOp output <small>Note 3</small>	tkSO2	C = 30 pF <small>Note 4</small>			2/fMCK + 44		2/fMCK + 110		2/fMCK + 110	ns

- Note 1.** When DAPmn = 0 and CKPmn = 0, or DAPmn = 1 and CKPmn = 1.  
The Slp setup time becomes “to SCKp↓” when DAPmn = 0 and CKPmn = 1, or DAPmn = 1 and CKPmn = 0.
- Note 2.** When DAPmn = 0 and CKPmn = 0, or DAPmn = 1 and CKPmn = 1.  
The Slp hold time becomes “from SCKp↓” when DAPmn = 0 and CKPmn = 1, or DAPmn = 1 and CKPmn = 0.
- Note 3.** When DAPmn = 0 and CKPmn = 0, or DAPmn = 1 and CKPmn = 1.  
The delay time to SOp output becomes “from SCKp↑” when DAPmn = 0 and CKPmn = 1, or DAPmn = 1 and CKPmn = 0.
- Note 4.** C is the load capacitance of the SCKp and SOp output lines.
- Note 5.** The maximum transfer rate when using the SNOOZE mode is 1 Mbps.

**Caution** Select the normal input buffer for the Slp pin and the normal output mode for the SOp pin and SCKp pin by using port input mode register g (PIMg) and port output mode register g (POMg).

- Remark 1.** p: CSI number (p = 00, 10), m: Unit number (m = 0, 1), n: Channel number (n = 0 to 3), g: PIM number (g = 0, 1, 3 to 5, 14)
- Remark 2.** fMCK: Serial array unit operation clock frequency (Operation clock to be set by the CKSmn bit of serial mode register mn (SMRmn). m: Unit number, n: Channel number (mn = 00, 02))

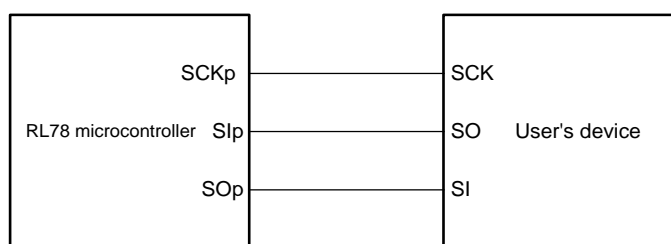

**CSI mode connection diagram (during communication at same potential)**

- Remark 1.** p: CSI number (p = 00, 10)
- Remark 2.** m: Unit number, n: Channel number (mn = 00, 02)

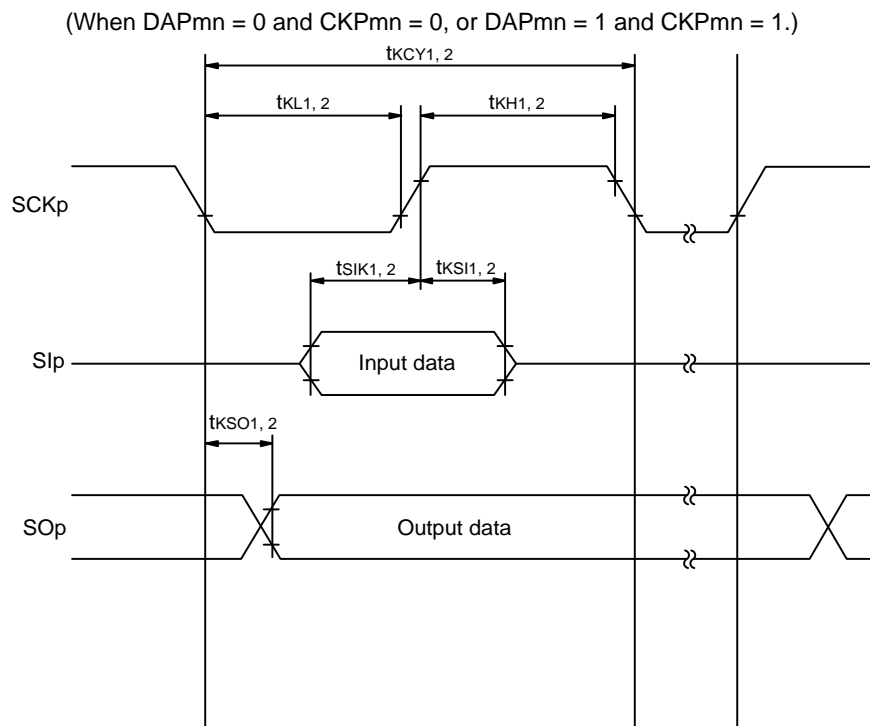

**CSI mode serial transfer timing (during communication at same potential)**

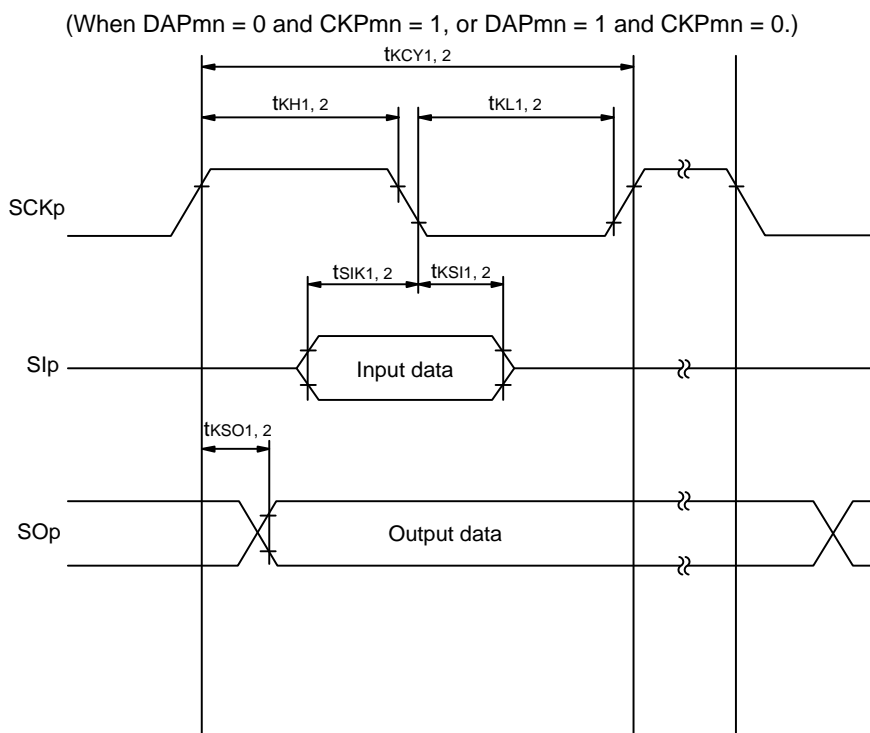

**CSI mode serial transfer timing (during communication at same potential)**

**Remark 1.** p: CSI number (p = 00, 10)

**Remark 2.** m: Unit number, n: Channel number (mn = 00, 02)

(4) During communication at same potential (simplified I<sup>2</sup>C mode)

(T<sub>A</sub> = -40/-20 to +85°C, 2.7 V ≤ VDD ≤ 5.5 V, GND0 = GND1 = VSS = 0 V)

Parameter	Symbol	Conditions	HS ( high-speed main ) mode		LS ( low-speed main ) mode		LV ( low-voltage main ) mode		Unit
			MIN.	MAX.	MIN.	MAX.	MIN.	MAX.	
SCLr clock frequency	f <sub>SCL</sub>	2.7 V ≤ VDD ≤ 5.5 V, Cb = 50 pF, Rb = 2.7 kΩ		1000 <sup>Note 1</sup>		400 <sup>Note 1</sup>		400 <sup>Note 1</sup>	kHz
Hold time when SCLr = "L"	t <sub>LOW</sub>	2.7 V ≤ VDD ≤ 5.5 V, Cb = 50 pF, Rb = 2.7 kΩ	475		1150		1150		ns
Hold time when SCLr = "H"	t <sub>HIGH</sub>	2.7 V ≤ VDD ≤ 5.5 V, Cb = 50 pF, Rb = 2.7 kΩ	475		1150		1150		ns
Data setup time (reception)	t <sub>SU: DAT</sub>	2.7 V ≤ VDD ≤ 5.5 V, Cb = 50 pF, Rb = 2.7 kΩ	1/f <sub>MCK</sub> + 85 <sup>Note 2</sup>		1/f <sub>MCK</sub> + 145 <sup>Note 2</sup>		1/f <sub>MCK</sub> + 145 <sup>Note 2</sup>		ns
Data hold time (transmission)	t <sub>HD: DAT</sub>	2.7 V ≤ VDD ≤ 5.5 V, Cb = 50 pF, Rb = 2.7 kΩ	0	305	0	305	0	305	ns

**Note 1.** The value must also be equal to or less than f<sub>MCK</sub>/4.

**Note 2.** Set the f<sub>MCK</sub> value not to over the hold time of SCLr = "L" and SCLr = "H".

**Caution** Select the normal input buffer and the N-ch open drain output (VDD tolerance) mode for the SDAr pin and the normal output mode for the SCLr pin by using port input mode register g (PIMg) and port output mode register h (POMh).

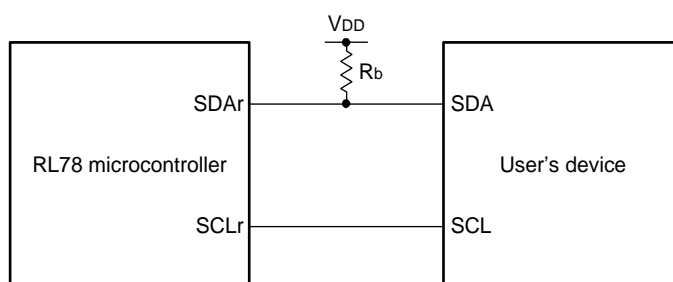

Simplified I<sup>2</sup>C mode connection diagram (during communication at same potential)

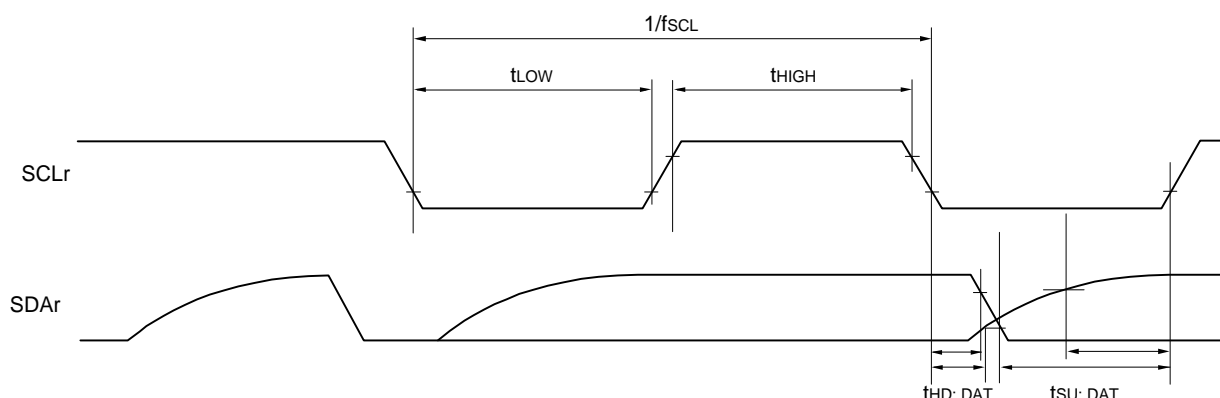

Simplified I<sup>2</sup>C mode serial transfer timing (during communication at same potential)

**Remark 1.** Rb[Ω]: Communication line (SDAr) pull-up resistance, Cb[F]: Communication line (SDAr, SCLr) load capacitance

**Remark 2.** r: IIC number (r = 00, 10), g: PIM number (g = 10, 13), h: POM number (h = 11, 14)

**Remark 3.** f<sub>MCK</sub>: Serial array unit operation clock frequency (Operation clock to be set by the CKSmn bit of serial mode register mn (SMRmn).

m: Unit number (m = 0, 1), n: Channel number (n = 0 to 3), mn = 00 to 03, 10 to 13)

## 4.7.2 Serial interface IICA

### (1) I<sup>2</sup>C standard mode

(T<sub>A</sub> = -40/-20 to +85°C, 2.7 V ≤ VDD ≤ 5.5 V, GND0 = GND1 = VSS = 0 V)

Parameter	Symbol	Conditions	HS (high-speed main) mode		LS (low-speed main) mode		LV (low-voltage main) mode		Unit
			MIN.	MAX.	MIN.	MAX.	MIN.	MAX.	
SCLA0 clock frequency	fSCL	Standard mode: fCLK ≥ 1 MHz	0	100	0	100	0	100	kHz
Setup time of restart condition	tSU: STA		4.7		4.7		4.7		us
Hold time <sup>Note 1</sup>	tHD: STA		4.0		4.0		4.0		us
Hold time when SCLA0 = "L"	tLOW		4.7		4.7		4.7		us
Hold time when SCLA0 = "H"	tHIGH		4.0		4.0		4.0		us
Data setup time (reception)	tSU: DAT		250		250		250		ns
Data hold time (transmission) <sup>Note 2</sup>	tHD: DAT		0	3.45	0	3.45	0	3.45	us
Setup time of stop condition	tSU: STO		4.0		4.0		4.0		us
Bus-free time	tBUF		4.7		4.7		4.7		us

**Note 1.** The first clock pulse is generated after this period when the start/restart condition is detected.

**Note 2.** The maximum value (MAX.) of tHD: DAT is during normal transfer and a wait state is inserted in the ACK (acknowledge) timing.

**Remark** The maximum value of C<sub>b</sub> (communication line capacitance) and the value of R<sub>b</sub> (communication line pull-up resistor) at that time in each mode are as follows.

Standard mode: C<sub>b</sub> = 400p F, R<sub>b</sub> = 2.7 kΩ

(2) I<sup>2</sup>C fast mode(T<sub>A</sub> = -40/-20 to +85°C, 2.7 V ≤ VDD ≤ 5.5 V, GND0 = GND1 = VSS = 0 V)

Parameter	Symbol	Conditions	HS (high-speed main) mode		LS (low-speed main) mode		LV (low-voltage main) mode		Unit
			MIN.	MAX.	MIN.	MAX.	MIN.	MAX.	
SCLA0 clock frequency	fSCL	Fast mode: fCLK ≥ 3.5 MHz	0	400	0	400	0	400	kHz
Setup time of restart condition	tSU: STA		0.6		0.6		0.6		us
Hold time <sup>Note1</sup>	tHD: STA		0.6		0.6		0.6		us
Hold time when SCLA0 = "L"	tLOW		1.3		1.3		1.3		us
Hold time when SCLA0 = "H"	tHIGH		0.6		0.6		0.6		us
Data setup time (reception)	tSU: DAT		100		100		100		ns
Data hold time (transmission) <sup>Note2</sup>	tHD: DAT		0	0.9	0	0.9	0	0.9	us
Setup time of stop condition	tSU: STO		0.6		0.6		0.6		us
Bus-free time	tBUF		1.3		1.3		1.3		us

**Note 1.** The first clock pulse is generated after this period when the start/restart condition is detected.

**Note 2.** The maximum value (MAX.) of tHD: DAT is during normal transfer and a wait state is inserted in the ACK (acknowledge) timing.

**Remark** The maximum value of C<sub>b</sub> (communication line capacitance) and the value of R<sub>b</sub> (communication line pull-up resistor) at that time in each mode are as follows.

Fast mode: C<sub>b</sub> = 320 pF, R<sub>b</sub> = 1.1 kΩ

(3) I<sup>2</sup>C fast mode plus

(T<sub>A</sub> = -40/-20 to +85°C, 2.7 V ≤ VDD ≤ 5.5 V, GND0 = GND1 = VSS = 0 V)

Parameter	Symbol	Conditions	HS (high-speed main) mode		LS (low-speed main) mode		LV (low-voltage main) mode		Unit
			MIN.	MAX.	MIN.	MAX.	MIN.	MAX.	
SCLA0 clock frequency	fSCL	Fast mode plus: fCLK ≥ 10 MHz	0	1000					kHz
Setup time of restart condition	tSU: STA		0.26						us
Hold time <sup>Note 1</sup>	tHD: STA		0.26						us
Hold time when SCLA0 = "L"	tLOW		0.5						us
Hold time when SCLA0 = "H"	tHIGH		0.26						us
Data setup time (reception)	tSU: DAT		50						ns
Data hold time (transmission) <sup>Note 2</sup>	tHD: DAT		0	0.45					us
Setup time of stop condition	tSU: STO		0.26						us
Bus-free time	tBUF		0.5						us

**Note 1.** The first clock pulse is generated after this period when the start/restart condition is detected.

**Note 2.** The maximum value (MAX.) of tHD: DAT is during normal transfer and a wait state is inserted in the ACK (acknowledge) timing.

**Remark** The maximum value of C<sub>b</sub> (communication line capacitance) and the value of R<sub>b</sub> (communication line pull-up resistor) at that time in each mode are as follows.

Fast mode plus: C<sub>b</sub> = 120 pF, R<sub>b</sub> = 1.1 kΩ

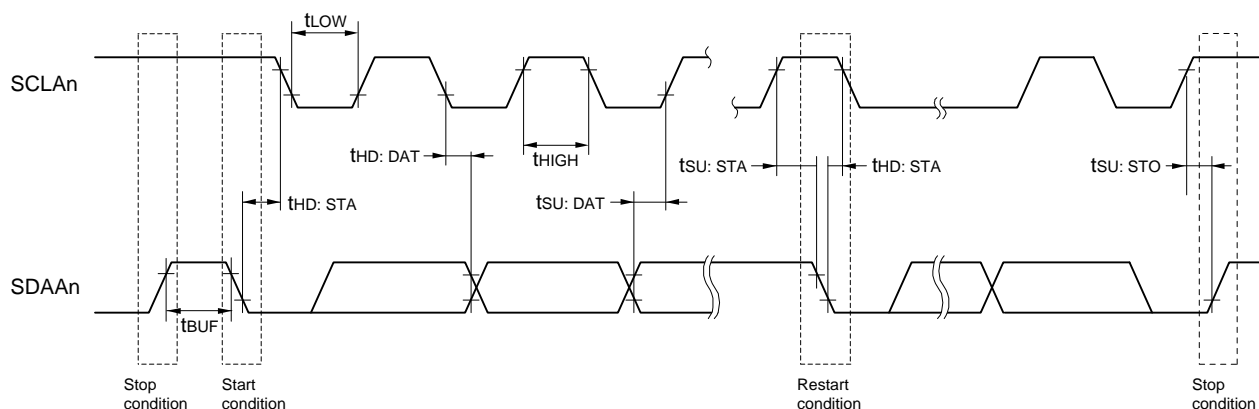

I<sup>2</sup>C serial transfer timing

**Remark** n = 0

**4.7.3 CAN interface**(T<sub>A</sub> = -40/-20 to +85°C, 2.7 V ≤ VDD ≤ 5.5 V, GND0 = GND1 = VSS = 0 V)

Parameter	Symbol	Conditions	HS ( high-speed main ) mode		Unit
			MIN.	MAX.	
Transfer rate		Theoretical value of the maximum transfer rate f <sub>CAN</sub> = fCLK/2		1	Mbps

### 4.7.4 A/D converter characteristics

(1) When reference voltage (+) =  $AV_{REFP}/ANI0$  ( $ADREFP1 = 0, ADREFP0 = 1$ ), reference voltage (-) =  $AV_{REFM}/ANI1$  ( $ADREFM = 1$ ), target pin: ANI02, ANI03, internal reference voltage, and temperature sensor output voltage

( $T_A = -40/-20$  to  $+85^{\circ}\text{C}$ ,  $2.7\text{ V} \leq AV_{REFP} = VDD \leq 5.5\text{ V}$ ,  $GND0 = GND1 = VSS = 0\text{ V}$ , Reference voltage (+) =  $AV_{REFP}$ , Reference voltage (-) =  $AV_{REFM} = 0\text{ V}$ )

Parameter	Symbol	Conditions	MIN.	TYP.	MAX.	Unit
Resolution	RES		8		10	bits
Overall error <sup>Note 1</sup>	AINL	10-bit resolution $AV_{REFP} = VDD$ <sup>Note 3</sup>	$2.7\text{ V} \leq AV_{REFP} \leq 5.5\text{ V}$	1.2	$\pm 3.5$	LSB
Conversion time	tCONV	10-bit resolution Target pin: ANI02-ANI03	$3.6\text{ V} \leq VDD \leq 5.5\text{ V}$	2.125	39	us
			$2.7\text{ V} \leq VDD \leq 5.5\text{ V}$	3.1875	39	us
		10-bit resolution Target pin: Internal reference voltage, and temperature sensor output voltage (HS (high-speed main) mode)	$3.6\text{ V} \leq VDD \leq 5.5\text{ V}$	2.375	39	us
			$2.7\text{ V} \leq VDD \leq 5.5\text{ V}$	3.5625	39	us
Zero-scale error <sup>Note 1, 2</sup>	EZS	10-bit resolution $AV_{REFP} = VDD$ <sup>Note 3</sup>	$2.7\text{ V} \leq AV_{REFP} \leq 5.5\text{ V}$		$\pm 0.25$	%FSR
Full-scale error <sup>Note 1, 2</sup>	EFS	10-bit resolution $AV_{REFP} = VDD$ <sup>Note 3</sup>	$2.7\text{ V} \leq AV_{REFP} \leq 5.5\text{ V}$		$\pm 0.25$	%FSR
Integral linearity error <sup>Note 1</sup>	ILE	10-bit resolution $AV_{REFP} = VDD$ <sup>Note 3</sup>	$2.7\text{ V} \leq AV_{REFP} \leq 5.5\text{ V}$		$\pm 2.5$	LSB
Differential linearity error <sup>Note 1</sup>	DLE	10-bit resolution $AV_{REFP} = VDD$ <sup>Note 3</sup>	$2.7\text{ V} \leq AV_{REFP} \leq 5.5\text{ V}$		$\pm 1.5$	LSB
Analog input voltage	VAIN	ANI02 to ANI03	0		$AV_{REFP}$	V
		Internal reference voltage ( $2.7\text{ V} \leq VDD \leq 5.5\text{ V}$ , HS (high-speed main) mode)	$V_{BGR}$ <sup>Note 4</sup>			V
		Temperature sensor output voltage ( $2.7\text{ V} \leq VDD \leq 5.5\text{ V}$ , HS (high-speed main) mode)	$V_{TMS25}$ <sup>Note 4</sup>			V

**Note 1.** Excludes quantization error ( $\pm 1/2$  LSB).

**Note 2.** This value is indicated as a ratio (%FSR) to the full-scale value.

**Note 3.** When  $AV_{REFP} < VDD$ , the MAX. values are as follows.

Overall error: Add  $\pm 1.0$  LSB to the MAX. value when  $AV_{REFP} = VDD$ .

Zero-scale error/Full-scale error: Add  $\pm 0.05\%$ FSR to the MAX. value when  $AV_{REFP} = VDD$ .

Integral linearity error/ Differential linearity error: Add  $\pm 0.5$  LSB to the MAX. value when  $AV_{REFP} = VDD$ .

**Note 4.** Refer to Section 4.7.5 Temperature sensor characteristics/internal reference voltage characteristic.

(2) When reference voltage (+) = VDD (ADREFP1 = 0, ADREFP0 = 0), reference voltage (-) = VSS (ADREFM = 0),

target pin: ANI00 to ANI03, internal reference voltage, and temperature sensor output voltage

( $T_A = -40/-20$  to  $+85^\circ\text{C}$ ,  $2.7\text{ V} \leq \text{VDD} \leq 5.5\text{ V}$ ,  $\text{GND0} = \text{GND1} = \text{VSS} = 0\text{ V}$ , Reference voltage (+) = VDD, Reference voltage (-) = VSS)

Parameter	Symbol	Conditions	MIN.	TYP.	MAX.	Unit
Resolution	RES		8		10	bits
Overall error <sup>Note 1</sup>	AINL	10-bit resolution		1.2	$\pm 7.0$	LSB
Conversion time	t <sub>CONV</sub>	10-bit resolution Target pin: ANI00 to ANI03	$3.6\text{ V} \leq \text{VDD} \leq 5.5\text{ V}$	2.125	39	us
			$2.7\text{ V} \leq \text{VDD} \leq 5.5\text{ V}$	3.1875	39	us
		10-bit resolution Target pin: Internal reference voltage, and temperature sensor output voltage (HS (high-speed main) mode)	$3.6\text{ V} \leq \text{VDD} \leq 5.5\text{ V}$	2.375	39	us
			$2.7\text{ V} \leq \text{VDD} \leq 5.5\text{ V}$	3.5625	39	us
Zero-scale error <sup>Note 1, 2</sup>	E <sub>zs</sub>	10-bit resolution			$\pm 0.60$	%FSR
Full-scale error <sup>Note 1, 2</sup>	E <sub>fs</sub>	10-bit resolution			$\pm 0.60$	%FSR
Integral linearity error <sup>Note 1</sup>	ILE	10-bit resolution			$\pm 4.0$	LSB
Differential linearity <sup>Note 1</sup>	DLE	10-bit resolution			$\pm 2.0$	LSB
Analog input voltage	V <sub>AIN</sub>	ANI0 to ANI3	0		V <sub>DD</sub>	V
		Internal reference voltage ( $2.7\text{ V} \leq \text{VDD} \leq 5.5\text{ V}$ , HS (high-speed main) mode)	V <sub>BGR</sub> <sup>Note 3</sup>			V
		Temperature sensor output voltage ( $2.7\text{ V} \leq \text{VDD} \leq 5.5\text{ V}$ , HS (high-speed main) mode)	V <sub>TMPS25</sub> <sup>Note 3</sup>			V

**Note 1.** Excludes quantization error ( $\pm 1/2$  LSB).

**Note 2.** This value is indicated as a ratio (% FSR) to the full-scale value.

**Note 3.** Refer to Section 4.7.5 Temperature sensor characteristics/internal reference voltage characteristic.

(3) When reference voltage (+) = Internal reference voltage (ADREFP1 = 1, ADREFP0 = 0), reference voltage (-) = AVREFM/ANI1 (ADREFM = 1), target pin: ANI00, ANI02, ANI03

(T<sub>A</sub> = -40/-20 to +85°C, 2.7 V ≤ VDD ≤ 5.5 V, GND0 = GND1 = VSS = 0 V, Reference voltage (+) = VBGR <sup>Note 3</sup>, Reference voltage (-) = AVREFM = 0V Note 4, HS (high-speed main) mode)

Parameter	Symbol	Conditions	MIN.	TYP.	MAX.	Unit
Resolution	RES		8		bits	
Conversion time	tCONV	8-bit resolution	17		39	us
Zero-scale error <sup>Note 1, 2</sup>	Ezs	8-bit resolution			±0.60	%FSR
Integral linearity error <sup>Note 1</sup>	ILE	8-bit resolution			±2.0	LSB
Differential linearity error <sup>Note 1</sup>	DLE	8-bit resolution			±1.0	LSB
Analog input voltage	VAIN		0		VBGR <sup>Note 3</sup>	V

**Note 1.** Excludes quantization error (±1/2 LSB).

**Note 2.** This value is indicated as a ratio (% FSR) to the full-scale value.

**Note 3.** Refer to 4.7.5 Temperature sensor characteristics/internal reference voltage characteristic.

**Note 4.** When reference voltage (-) = VSS, the MAX. values are as follows.

Zero-scale error: Add ±0.35%FSR to the MAX. value when reference voltage (-) = AVREFM.

Integral linearity error: Add ±0.5 LSB to the MAX. value when reference voltage (-) = AVREFM.

Differential linearity error: Add ±0.2 LSB to the MAX. value when reference voltage (-) = AVREFM.

**4.7.5 Temperature sensor characteristics/internal reference voltage characteristic**(T<sub>A</sub> = -40/-20 to +85°C, 2.7 V ≤ VDD ≤ 5.5 V, GND0 = GND1 = VSS = 0 V)

Parameter	Symbol	Conditions	MIN.	TYP.	MAX.	Unit
Temperature sensor output	VTMPS25	Setting ADS register = 80H, T <sub>A</sub> = +25°C		1.05		V
Internal reference voltage	VBGR	Setting ADS register = 81H	1.38	1.45	1.5	V
Temperature coefficient	FVTMPS	Temperature sensor that depends on the temperature		-3.6		mV/C
Operation stabilization wait time	tAMP		5			us

### 4.7.6 POR circuit characteristics (MCU)

( $T_A = -40/-20$  to  $+85^\circ\text{C}$ ,  $\text{GND0} = \text{GND1} = \text{VSS} = 0 \text{ V}$ )

Parameter	Symbol	Conditions	MIN.	TYP.	MAX.	Unit
Power on/down reset threshold	VPOR	Voltage threshold on VDD rising	1.47	1.51	1.55	V
	VPDR	Voltage threshold on VDD falling <sup>Note 1</sup>	1.46	1.50	1.54	V
Minimum pulse width <sup>Note 2</sup>	TPW		300			us

**Note 1.** However, when operating voltage drops when LVD is off, it enters STOP mode, or enable the reset status using external reset pin before the voltage drops below the operating voltage range shown in Section 4.6 AC Characteristics.

**Note 2.** Minimum time required for POR to reset when VDD is below VPDR. This is also the minimum time required for a POR reset when VDD exceeds VPOR after VDD is below 0.7 V during STOP mode or while the main system clock is stopped by setting bit 0 (HIOSTOP) and bit 7 (MSTOP) in the clock operation status control register (CSC).

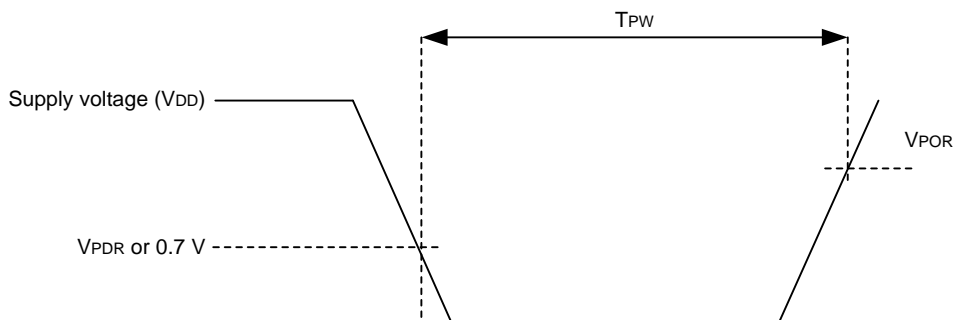

**4.7.7 LVD circuit characteristics**

(1) Reset Mode and Interrupt Mode

(T<sub>A</sub>= -40/-20 to +85°C, VPDR ≤ VDD ≤5.5 V, GND0 = GND1 = VSS= 0 V)

Parameter	Symbol	Conditions	MIN.	TYP.	MAX.	Unit
Voltage detection threshold	V <sub>LV10</sub>	Power supply rise time	3.98	4.06	4.14	V
		Power supply fall time	3.90	3.98	4.06	V
	V <sub>LV11</sub>	Power supply rise time	3.68	3.75	3.82	V
		Power supply fall time	3.60	3.67	3.74	V
	V <sub>LV12</sub>	Power supply rise time	3.07	3.13	3.19	V
		Power supply fall time	3.00	3.06	3.12	V
	V <sub>LV13</sub>	Power supply rise time	2.96	3.02	3.08	V
		Power supply fall time	2.90	2.96	3.02	V
	V <sub>LV14</sub>	Power supply rise time	2.86	2.92	2.97	V
		Power supply fall time	2.80	2.86	2.91	V
	V <sub>LV15</sub>	Power supply rise time	2.76	2.81	2.87	V
		Power supply fall time	2.70	2.75	2.81	V
	V <sub>LV16</sub>	Power supply rise time	2.66	2.71	2.76	V
		Power supply fall time	2.60	2.65	2.70	V
	V <sub>LV17</sub>	Power supply rise time	2.56	2.61	2.66	V
		Power supply fall time	2.50	2.55	2.60	V
	V <sub>LV18</sub>	Power supply rise time	2.45	2.50	2.55	V
		Power supply fall time	2.40	2.45	2.50	V
	V <sub>LV19</sub>	Power supply rise time	2.05	2.09	2.13	V
		Power supply fall time	2.00	2.04	2.08	V
	V <sub>LV110</sub>	Power supply rise time	1.94	1.98	2.02	V
		Power supply fall time	1.90	1.94	1.98	V
	V <sub>LV111</sub>	Power supply rise time	1.84	1.88	1.91	V
		Power supply fall time	1.80	1.84	1.87	V
V <sub>LV112</sub>	Power supply rise time	1.74	1.77	1.81	V	
	Power supply fall time	1.70	1.73	1.77	V	
V <sub>LV113</sub>	Power supply rise time	1.64	1.67	1.70	V	
	Power supply fall time	1.60	1.63	1.66	V	
Minimum pulse width	t <sub>LW</sub>		300			μs
Detection delay time	t <sub>LD</sub>				300	μs

(1) Interrupt & Reset Mode

(T<sub>A</sub>= -40/-20 to +85°C, VPDR ≤ VDD ≤5.5 V, GND0 = GND1 = VSS= 0 V)

Parameter	Symbol	Conditions	MIN.	TYP.	MAX.	Unit	
Voltage detection threshold	V <sub>LVDA0</sub>	VPOC2, VPOC1, VPOC0 = 0, 0, 0, falling reset voltage	1.60	1.63	1.66	V	
	V <sub>LVDA1</sub>	LVIS0, LVIS1 = 1, 0	Rising release reset voltage	1.74	1.77	1.81	V
			Falling interrupt voltage	1.70	1.73	1.77	V
	V <sub>LVDA2</sub>	LVIS0, LVIS1 = 0, 1	Rising release reset voltage	1.84	1.88	1.91	V
			Falling interrupt voltage	1.80	1.84	1.87	V
	V <sub>LVDA3</sub>	LVIS0, LVIS1 = 0, 0	Rising release reset voltage	2.86	2.92	2.97	V
			Falling interrupt voltage	2.80	2.86	2.91	V
	V <sub>LVDB0</sub>	VPOC2, VPOC1, VPOC0 = 0, 0, 1, falling reset voltage	1.80	1.84	1.87	V	
	V <sub>LVDB1</sub>	LVIS0, LVIS1 = 1, 0	Rising release reset voltage	1.94	1.98	2.02	V
			Falling interrupt voltage	1.90	1.94	1.98	V
	V <sub>LVDB2</sub>	LVIS0, LVIS1 = 0, 1	Rising release reset voltage	2.05	2.09	2.13	V
			Falling interrupt voltage	2.00	2.04	2.08	V
	V <sub>LVDB3</sub>	LVIS0, LVIS1 = 0, 0	Rising release reset voltage	3.07	3.13	3.19	V
			Falling interrupt voltage	3.00	3.06	3.12	V
	V <sub>LVDC0</sub>	VPOC2, VPOC1, VPOC0 = 0, 1, 0, falling reset voltage	2.40	2.45	2.50	V	
	V <sub>LVDC1</sub>	LVIS0, LVIS1 = 1, 0	Rising release reset voltage	2.56	2.61	2.66	V
			Falling interrupt voltage	2.50	2.55	2.60	V
	V <sub>LVDC2</sub>	LVIS0, LVIS1 = 0, 1	Rising release reset voltage	2.66	2.71	2.76	V
			Falling interrupt voltage	2.60	2.65	2.70	V
	V <sub>LVDC3</sub>	LVIS0, LVIS1 = 0, 0	Rising release reset voltage	3.68	3.75	3.82	V
			Falling interrupt voltage	3.60	3.67	3.74	V
	V <sub>LVDD0</sub>	VPOC2, VPOC1, VPOC0 = 0, 1, 1, falling reset voltage	2.70	2.75	2.81	V	
	V <sub>LVDD1</sub>	LVIS0, LVIS1 = 1, 0	Rising release reset voltage	2.86	2.92	2.97	V
			Falling interrupt voltage	2.80	2.86	2.91	V
V <sub>LVDD2</sub>	LVIS0, LVIS1 = 0, 1	Rising release reset voltage	2.96	3.02	3.08	V	
		Falling interrupt voltage	2.90	2.96	3.02	V	
V <sub>LVDD3</sub>	LVIS0, LVIS1 = 0, 0	Rising release reset voltage	3.98	4.06	4.14	V	
		Falling interrupt voltage	3.90	3.98	4.06	V	

## 4.8 AFE peripheral circuit characteristics

### 4.8.1 High-voltage port characteristics

( $T_A = -40/-20$  to  $+85^\circ\text{C}$ ,  $4.0\text{ V} \leq V_{CC} \leq 50\text{ V}$ ,  $GND0 = GND1 = VSS = 0\text{ V}$ )

Parameter	Symbol	Conditions	MIN.	TYP.	MAX.	Unit
Input voltage, high	$V_{IH}$		2.6			V
Input voltage, low	$V_{IL}$				0.7	V
Output voltage, high	$V_{OH}$	$I_{OH} = -1\text{ mA}$	$V_{CC}-0.7$		$V_{CC}$	V
Output voltage, low	$V_{OL}$	$I_{OL} = 1\text{ mA}$			0.7	V
On resistance, high level output (Pch MOS output)	$R_{ONP}$	$I_{OH} = -1\text{ mA}$			700	$\Omega$
On resistance, high level output (Nch MOS output)	$R_{ONN}$	$I_{OL} = 1\text{ mA}$			700	$\Omega$
Pin leakage current	$I_{LK}$	$V_I = V_{CC}, GND$			$\pm 1$	$\mu\text{A}$

**4.8.2 Multiplexer characteristics**

(T<sub>A</sub> = -40/-20 to +85°C, 4.0 V ≤ VCC ≤ 50 V, GND0 = GND1 = VSS = 0 V)

Parameter	Symbol	Conditions	MIN.	TYP.	MAX.	Unit
Gain VIN(n)-VIN(n-1)	GAIN1	VIN10, VIN9, VIN8, VIN7, VIN6, VIN5 > 2.0V VIN4, VIN3, VIN2, VIN1, VIN0 > 0V <sup>Note</sup>		1.0		V/V
Gain PACK, VIN10, PON	GAIN2			0.1		V/V
Gain AN0,1,2	GAIN3			1.0		V/V
Input voltage range VIN(n)-VIN(n-1)	VRA1	VIN10, VIN9, VIN8, VIN7, VIN6, VIN5 > 2.0V VIN4, VIN3, VIN2, VIN1, VIN0 > 0V <sup>Note</sup>	-0.1		5.1	V
Input voltage range PACK, VIN10, PON	VRA2		0.0		50.0	V
Input voltage range AN0, 1, 2	VRA3		0.0		1.8	V
Pin leakage current	ILKV1	VIN1 = 5 V			2	μA
		VIN2 = 10 V			2	μA
		VIN3 = 15 V			2	μA
		VIN4 = 20 V			2	μA
		VIN5 = 25 V			2	μA
		VIN6 = 30 V			2	μA
		VIN7 = 35 V			2	μA
		VIN8 = 40 V			2	μA
		VIN9 = 45 V			2	μA
		VIN10 = 50 V			2	μA

**Note** Reference voltage is GND0 and GND1

### 4.8.3 Sigma-delta A/D converter characteristics

( $T_A = -40/-20$  to  $+85^\circ\text{C}$ ,  $4.0\text{ V} \leq V_{CC} \leq 50\text{ V}$ ,  $\text{GND0} = \text{GND1} = \text{VSS} = 0\text{ V}$ )

Parameter	Symbol	Conditions	MIN.	TYP.	MAX.	Unit
Resolution <sup>Note1</sup>	RESAD	Conversion time = 8 ms			15	bits
		Conversion time = 4 ms			14	bits
		Conversion time = 2 ms			13	bits
		Conversion time = 1 ms			12	bits
		Conversion time = 0.5 ms			11	bits
		Conversion time = 0.25 ms			10	bits
Input voltage range	VINAD		-0.1		5.1	V
Integral nonlinearity	INLAD	End fit	-27		27	LSB
Conversion result in zero input	ADZERO	VIN = 0 V		3317 <sup>Note 2</sup>		LSB
Temperature dependency in zero input	dTADZERO	VIN = 0 V	-0.24		+0.24	LSB/C
Conversion result in full-scale input	ADFS	VIN = 5.1 V		24100 <sup>Note 2</sup>		LSB
Temperature dependency in full-scale input	dTADFS	VIN = 5.1 V	-0.24		+0.24	LSB/C
Input resistance	RINAD			(1.0)		MΩ
Battery cell voltage measurement error	ERRCELL1	$T_A = +25^\circ\text{C}$ After calibration			±5	mV
	ERRCELL2	$-20\text{C} \leq T_A \leq 85^\circ\text{C}$ After calibration			±10	mV
	ERRCELL2L	$-40\text{C} \leq T_A \leq 85^\circ\text{C}$ After calibration			±12	mV

**Note 1.** AD conversion result is output in 15-bit.

**Note 2.** This value is before subtracting the offset voltage.

**Caution 1.** Except for Battery cell voltage measurement error (ERRCELL), these parameters are sigma-delta converter circuit characteristics.

**Caution 2.** Calibration is needed to keep high accuracy in system.

**Remark** Values in brackets are design value.

#### 4.8.4 Current integrating circuit characteristics

( $T_A = -40/-20$  to  $+85^\circ\text{C}$ ,  $4.0\text{ V} \leq V_{CC} \leq 50\text{ V}$ ,  $\text{GND0} = \text{GND1} = V_{SS} = 0\text{ V}$ )

Parameter	Symbol	Conditions	MIN.	TYP.	MAX.	Unit
Resolution	RESCC				18	bits
Conversion time	TCC			250		ms
Input voltage range	VINCC	$\pm 50\text{ mV}$ mode ISENS1 to ISENS0	-50		+50	mV
		$\pm 100\text{ mV}$ mode ISENS1 to ISENS0	-100		+100	mV
		$\pm 200\text{ mV}$ mode ISENS1 to ISENS0	-200		+200	mV
Integral nonlinearity	INLCC	End fit			0.02	%FSR
Input resistance	RINCC	ISENS0, ISENS1		(1.0)		$\text{M}\Omega$
Current measurement error	ERRCURR	$\pm 50\text{ mV}$ mode, $-20^\circ\text{C} \leq T_A \leq 85^\circ\text{C}$ After calibration			( $\pm 25$ )	$\mu\text{V}$
		$\pm 50\text{ mV}$ mode, $-40^\circ\text{C} \leq T_A \leq 85^\circ\text{C}$ After calibration			( $\pm 30$ )	$\mu\text{V}$
		$\pm 100\text{ mV}$ mode $-20^\circ\text{C} \leq T_A \leq 85^\circ\text{C}$ After calibration			( $\pm 50$ )	$\mu\text{V}$
		$\pm 100\text{ mV}$ mode $-40^\circ\text{C} \leq T_A \leq 85^\circ\text{C}$ After calibration			( $\pm 60$ )	$\mu\text{V}$
		$\pm 200\text{ mV}$ mode $-20^\circ\text{C} \leq T_A \leq 85^\circ\text{C}$ After calibration Input voltage range: $-100\text{ mV}$ to $200\text{ mV}$			( $\pm 100$ )	$\mu\text{V}$
		$\pm 200\text{ mV}$ mode $-40^\circ\text{C} \leq T_A \leq 85^\circ\text{C}$ After calibration Input voltage range: $-100\text{ mV}$ to $200\text{ mV}$			( $\pm 120$ )	$\mu\text{V}$

**Caution 1.** Except for Current measurement error (ERRCURR), these parameters are current integration circuit characteristics.

**Caution 2.** Calibration is needed to keep high accuracy in system.

**Remark** Values in brackets are design value.

### 4.8.5 Overcurrent detection / wakeup current detection circuit characteristics

( $T_A = -40/-20$  to  $+85^\circ\text{C}$ ,  $4.0\text{ V} \leq V_{CC} \leq 50\text{ V}$ ,  $\text{GND0} = \text{GND1} = \text{VSS} = 0\text{ V}$ )

Parameter	Symbol	Conditions	MIN.	TYP.	MAX.	Unit
Discharge short-circuit current detection setting voltage step	dSVSC	25 mV to 200 mV		12.5		mV
		200 mV to 300 mV		25		mV
Discharge short-circuit current detection voltage error	dVSC	25 mV to 200 mV setting			$\pm 12.5$	mV
		225 mV to 300 mV setting			$\pm 25.0$	mV
Discharge overcurrent detection setting voltage step	dSVDOC	15 mV to 100 mV		2.5		mV
		100 mV to 200 mV		5		mV
Discharge overcurrent detection voltage error <sup>Note 1</sup>	dVDOC	15 mV to 100 mV setting			$\pm 5.0$	mV
		105 mV to 200 mV setting			$\pm 7.5$	mV
Charge overcurrent detection setting voltage step	dSVCOC	-60 mV to -2.5 mV		2.5		mV
		-100 mV to -60 mV		5		mV
Charge overcurrent detection voltage error <sup>Note 1</sup>	dVCOC	-60 mV to -2.5 mV setting			$\pm 5.0$	mV
		-100 mV to -65 mV setting			$\pm 7.5$	mV
Discharge wakeup current detection setting voltage step	dSVDWU	0 mV to 140 mV		1.25		mV
Charge wakeup current detection setting voltage step	dSVCWU	-140 mV to 0 mV		1.25		mV
DBPT current detection setting voltage step	dSVDBPT	0 mV to 140 mV		1.25		mV
Discharge wakeup current detection voltage error <sup>Note 1</sup>	dVDWU	20 times mode ISENS1 to ISENS0: 0.25 mV to 2.5 mV	-0.10	0.0	+0.25	mV
Charge wakeup current detection voltage error <sup>Note 1</sup>	dVCWU	20 times mode ISENS1 to ISENS0: -0.25 mV to -2.5 mV	-0.25	0.0	+0.10	mV
DBPT current detection voltage error <sup>Note 1</sup>	dVDBPT	20 times mode ISENS1 to ISENS0: 0.25 mV to 2.5 mV	-0.10	0.0	+0.25	mV
Discharge short-circuit current detection time error <sup>Note 2</sup>	dTSC	0 us to 916 us (61 us step)	0.0		30.5	us
Discharge overcurrent detection time error <sup>Note 2</sup>	dTDOC	0.488 ms to 32 s (0.488 ms step)	0.0		122	us
Charge overcurrent detection time error	dTCOC	0 us to 15564 us (61 us step)	0.0		30.5	us
Discharge wakeup current detection time error <sup>Note 2</sup>	dTDWU	3.91 ms to 62.56 ms (61 us step)	0		3.9	ms
Charge wakeup current detection time error <sup>Note 2</sup>	dTCWU	3.91 ms to 62.56 ms (61 us step)	0		3.9	ms
DBPT current detection time error <sup>Note 2</sup>	dTDBPT	0 us to 916 us (61 us step)	0.0		30.5	us

**Note 1.** This is the specification after zero-calibration is executed.

**Note 2.** The frequency error of On-chip oscillator (AOCO and ALOCO) is excluded from these detection time error.

### 4.8.6 Charge/discharge FET control circuit characteristics

( $T_A = -40/-20$  to  $+85^\circ\text{C}$ ,  $4.0\text{ V} \leq V_{CC} \leq 50\text{ V}$ ,  $GND0 = GND1 = V_{SS} = 0\text{ V}$ )

Parameter	Symbol	Conditions	MIN.	TYP.	MAX.	Unit
High-side Charge FET control Output voltage, CFOUT=H	CFON1	$4.0\text{ V} \leq V_{CC} < 6.0\text{ V}$ Load between CFOUT to VBAT = 50 nF/10 M $\Omega$ Based on VBAT pin	5.0	9.5	10.0	V
	CFON2	$6.0\text{ V} \leq V_{CC}$ , $-20^\circ\text{C} \leq T_A \leq 85^\circ\text{C}$ Load between CFOUT to VBAT = 50 nF/10 M $\Omega$ Based on VBAT pin	8.0	9.5	10.0	V
	CFON2L	$6.0\text{ V} \leq V_{CC}$ , $-40^\circ\text{C} \leq T_A \leq 85^\circ\text{C}$ Load between CFOUT to VBAT = 50 nF/10 M $\Omega$ Based on VBAT pin	6.5	9.5	10.0	V
High-side Charge FET control Output voltage, CFOUT=L	CFOFF	Load between CFOUT to VBAT = 50 nF/10 M $\Omega$ Based on VBAT pin	-0.2	0.0	0.2	V
High-side Charge FET control CFOUT rise Time	CFTR1	$4.0\text{ V} \leq V_{CC} < 6.0\text{ V}$ Load between CFOUT to VBAT = 50 nF/10 M $\Omega$ Lo(VBAT)→Hi(VBAT+5V)		1.5	2.5	ms
	CFTR2	$6.0\text{ V} \leq V_{CC}$ Load between CFOUT to VBAT = 50 nF/10 M $\Omega$ Lo(VBAT)→Hi(VBAT+5V)		1.0	1.5	ms
High-side Charge FET control CFOUT fall Time	CFTF1	Load between CFOUT to VBAT = 50 nF/10 M $\Omega$ Hi(VBAT+CFON1)→Lo(VBAT+1V) OFF speed acceleration = Disable		0.5	1.0	ms
	CFTF2	Load between CFOUT to VBAT = 50 nF/10 M $\Omega$ Hi(VBAT+CFON1)→Lo(VBAT+1V) OFF speed acceleration = Enable		(0.2)	(0.5)	ms
High-side Discharge FET control Output voltage, DFOUT=H	DFON1	$4.0\text{ V} \leq V_{CC} < 6.0\text{ V}$ Load between DFOUT to PACK = 50 nF/10 M $\Omega$ Based on PACK pin	5.0	9.5	10.0	V
	DFON2	$6.0\text{ V} \leq V_{CC}$ , $-20^\circ\text{C} \leq T_A \leq 85^\circ\text{C}$ Load between DFOUT to PACK = 50 nF/10 M $\Omega$ Based on PACK pin	8.0	9.5	10.0	V
	CFON2L	$6.0\text{ V} \leq V_{CC}$ , $-40^\circ\text{C} \leq T_A \leq 85^\circ\text{C}$ Load between CFOUT to VBAT = 50 nF/10 M $\Omega$ Based on VBAT pin	6.5	9.5	10.0	V
High-side Discharge FET control Output voltage, DFOUT=L	DFOFF	Load between DFOUT to PACK = 50 nF/10 M $\Omega$ Based on PACK pin	-0.2	0.0	0.2	V
High-side Discharge FET control DFOUT rise Time	DFTR1	$4.0\text{ V} \leq V_{CC} < 6.0\text{ V}$ Load between DFOUT to PACK = 50 nF/10 M $\Omega$ Lo(PACK)→Hi(PACK+5V)		1.5	2.5	ms
	DFTR2	$6.0\text{ V} \leq V_{CC}$ Load between DFOUT to PACK = 50 nF/10 M $\Omega$ Lo(PACK)→Hi(PACK+5V)		1.0	1.5	ms
High-side Discharge FET control DFOUT fall Time	DFTF1	Load between DFOUT to PACK = 50 nF/10 M $\Omega$ Hi(PACK+DFON1)→Lo(PACK+1V) OFF speed acceleration = Disable		0.5	1.0	ms
	DFTF2	Load between DFOUT to PACK = 50 nF/10 M $\Omega$ Hi(PACK+DFON1)→Lo(PACK+1V) OFF speed acceleration = Enable		(0.2)	(0.5)	ms
Low-side Charge FET control Clamp voltage	CCLPON1	Based on VBAT pin $4.0\text{ V} \leq V_{BAT} < 7.0\text{ V}$	-6.0		-3.0	V
	CCLPON2	Based on VBAT pin $7.0\text{ V} \leq V_{BAT}$	-14.0	-10.0	-6.0	V
Low-side Discharge FET control Clamp voltage	DCLPON1	Based on PACK pin $4.0\text{ V} \leq V_{PACK} < 7.0\text{ V}$	-6.0		-3.0	V
	DCLPON2	Based on PACK pin $7.0\text{ V} \leq V_{PACK}$	-14.0	-10.0	-6.0	V

**Caution** After trimming.

**Remark** Values in brackets are design value.

### 4.8.7 Power on circuit characteristics

( $T_A = -40/-20$  to  $+85^\circ\text{C}$ ,  $4.0\text{ V} \leq V_{CC} \leq 50\text{ V}$ ,  $\text{GND0} = \text{GND1} = \text{VSS} = 0\text{ V}$ )

Parameter	Symbol	Conditions	MIN.	TYP.	MAX.	Unit
Input voltage, High	$V_{IH}$		2.6		VCC	V
Input voltage, Low	$V_{IL}$		0.0		0.7	V
Pull-down resistance	Rdpon			12.4		MΩ

**Caution** To entry power down mode, it is necessary to input power down command while PON port is L.

### 4.8.8 Series regulator circuit characteristics

( $T_A = -40/-20$  to  $+85^\circ\text{C}$ ,  $4.0\text{ V} \leq V_{CC} \leq 50\text{ V}$ ,  $\text{GND0} = \text{GND1} = \text{VSS} = 0\text{ V}$ )

Parameter	Symbol	Conditions	MIN.	TYP.	MAX.	Unit
Output voltage	VR2O	3.3 V setting $I_o = 50\text{ uA}$ to $20\text{ mA}$ ,	3.20	3.30	3.40	V
	VR2O5	5.0 V setting $6.0\text{ V} \leq V_{CC} \leq 50.0\text{ V}$ , $I_o = 50\text{ uA}$ to $20\text{ mA}$	4.85	5.00	5.15	V
Load drive capability <sup>Note</sup>	IOMAX	3.3 V setting $4.0\text{ V} \leq V_{CC} < 5.0\text{ V}$	10.0			mA
			20.0			mA
	IOMAX5	5.0 V setting $6.0\text{ V} \leq V_{CC} < 7.0\text{ V}$	10.0			mA
			20.0			mA

**Note** In case of using load drive, total power consumption must be under the maximum ratings power consumption (Pd).

**Caution** After trimming.

### 4.8.9 AFE reset circuit characteristics

( $T_A = -40/-20$  to  $+85^\circ\text{C}$ ,  $4.0\text{ V} \leq V_{CC} \leq 50\text{ V}$ ,  $\text{GND0} = \text{GND1} = \text{VSS} = 0\text{ V}$ )

Parameter	Symbol	Conditions	MIN.	TYP.	MAX.	Unit
VREG2 release voltage	$V_{REL}$		2.8	2.9	3.0	V
VREG2 detection voltage	$V_{DET}$	After trimming	2.7	2.8	2.9	V

### 4.8.10 Cell balancing circuit characteristics

( $T_A = -40/-20$  to  $+85^\circ\text{C}$ ,  $4.0\text{ V} \leq V_{CC} \leq 50\text{ V}$ ,  $\text{GND0} = \text{GND1} = \text{VSS} = 0\text{ V}$ )

Parameter	Symbol	Conditions	MIN.	TYP.	MAX.	Unit
1st cell on resistance	RCOND1	$V_{IN1} - V_{IN0} = 3.5\text{ V}$	100	200	400	Ω
2nd cell on resistance	RCOND2	$V_{IN2} - V_{IN1} = 3.5\text{ V}$	100	200	400	Ω
3rd cell on resistance	RCOND3	$V_{IN3} - V_{IN2} = 3.5\text{ V}$	100	200	400	Ω
4th cell on resistance	RCOND4	$V_{IN4} - V_{IN3} = 3.5\text{ V}$	100	200	400	Ω
5th cell on resistance	RCOND5	$V_{IN5} - V_{IN4} = 3.5\text{ V}$	100	200	400	Ω
6th cell on resistance	RCOND6	$V_{IN6} - V_{IN5} = 3.5\text{ V}$	100	200	400	Ω
7th cell on resistance	RCOND7	$V_{IN7} - V_{IN6} = 3.5\text{ V}$	100	200	400	Ω
8th cell on resistance	RCOND8	$V_{IN8} - V_{IN7} = 3.5\text{ V}$	100	200	400	Ω
9th cell on resistance	RCOND9	$V_{IN9} - V_{IN8} = 3.5\text{ V}$	100	200	400	Ω
10th cell on resistance	RCOND10	$V_{IN10} - V_{IN9} = 3.5\text{ V}$	100	200	400	Ω

### 4.8.11 VREG2 Voltage Drop Detection Circuit characteristics

( $T_A = -40/-20$  to  $+85^\circ\text{C}$ ,  $4.0\text{ V} \leq V_{CC} \leq 50\text{ V}$ ,  $\text{GND0} = \text{GND1} = \text{VSS} = 0\text{ V}$ )

Parameter	Symbol	Conditions	MIN.	TYP.	MAX.	Unit
VREG2 Voltage detection threshold	VR2LVD	3.3 V setting	2.85	2.90	2.95	V
	VR2LVD5	5.0 V setting	4.55	4.60	4.65	V

### 4.9 RAM Data Retention Characteristics

( $T_A = -40/-20$  to  $+85^\circ\text{C}$ ,  $2.7\text{ V} \leq V_{DD} \leq 5.5\text{ V}$ ,  $GND0 = GND1 = VSS = 0\text{ V}$ )

Parameter	Symbol	Conditions	MIN.	TYP.	MAX.	Unit
Data retention supply voltage	VDDDR		1.46 <sup>Note</sup>		5.5	V

**Note** The value depends on the POR detection voltage. When the voltage drops, the RAM data is retained before a POR reset is effected, but RAM data is not retained when a POR reset is effected.

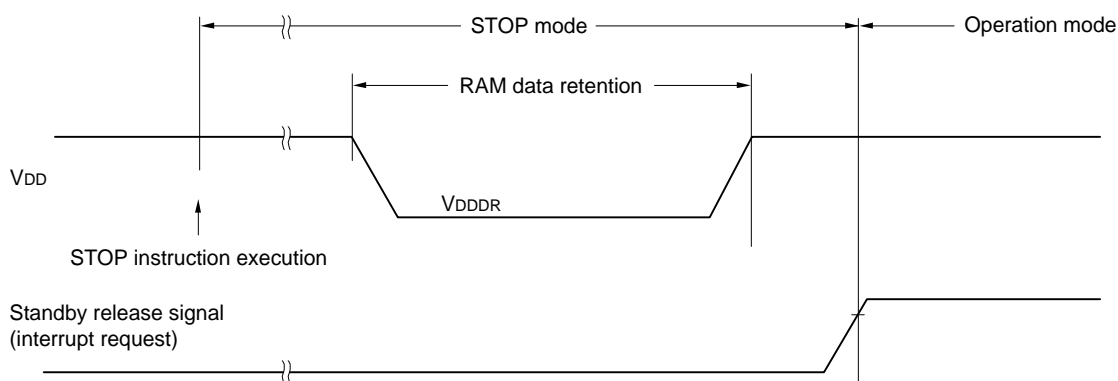

### 4.10 Flash Memory Programming Characteristics

( $T_A = -40/-20$  to  $+85^\circ\text{C}$ ,  $2.7\text{ V} \leq V_{DD} \leq 5.5\text{ V}$ ,  $GND0 = GND1 = VSS = 0\text{ V}$ )

Parameter	Symbol	Conditions	MIN.	TYP.	MAX.	Unit
System clock frequency	fCLK		1		32	MHz
Number of code flash rewrites <sup>Note 1, 2, 3</sup>	C <sub>erwr</sub>	Retained for 20 years $T_A = 85^\circ\text{C}$	1,000			Times
Number of data flash rewrites <sup>Note 1, 2, 3</sup>		Retained for 1 year $T_A = 25^\circ\text{C}$		1,000,000		
		Retained for 5 years $T_A = 85^\circ\text{C}$	100,000			
		Retained for 20 years $T_A = 85^\circ\text{C}$	10,000			

**Note 1.** 1 erase + 1 write after the erase is regarded as 1 rewrite. The retained years are until next rewrite completion.

**Note 2.** When using flash memory programmer and Renesas Electronics self-programming library

**Note 3.** These are the characteristics of the flash memory and the results obtained from reliability testing by Renesas Electronics Corporation.

### 4.11 Dedicated Flash Memory Programmer Communication (UART)

( $T_A = -40/-20$  to  $+85^\circ\text{C}$ ,  $2.7\text{ V} \leq V_{DD} \leq 5.5\text{ V}$ ,  $GND0 = GND1 = VSS = 0\text{ V}$ )

Parameter	Symbol	Conditions	MIN.	TYP.	MAX.	Unit
Transfer rate		During serial programming	115,200		1,000,000	bps

### 4.12 Timing of Entry to Flash Memory Programming Modes

( $T_A = -40/-20$  to  $+85^\circ\text{C}$ ,  $2.7\text{ V} \leq V_{DD} \leq 5.5\text{ V}$ ,  $GND0 = GND1 = VSS = 0\text{ V}$ )

Parameter	Symbol	Conditions	MIN.	TYP.	MAX.	Unit
The time needed when an external reset ends until the initial communication settings are specified	tsuINIT	POR and LVD reset must end before the external reset ends.			100	ms
The time needed from when the TOOL0 pin is placed at low level until an external reset ends	tsu	POR and LVD reset must end before the external reset ends.	10			us
The time needed for the TOOL0 pin must be kept at low level after an external reset ends (excluding the processing time of the firmware to control the flash memory)	tHD	POR and LVD reset must end before the external reset ends.	1			ms

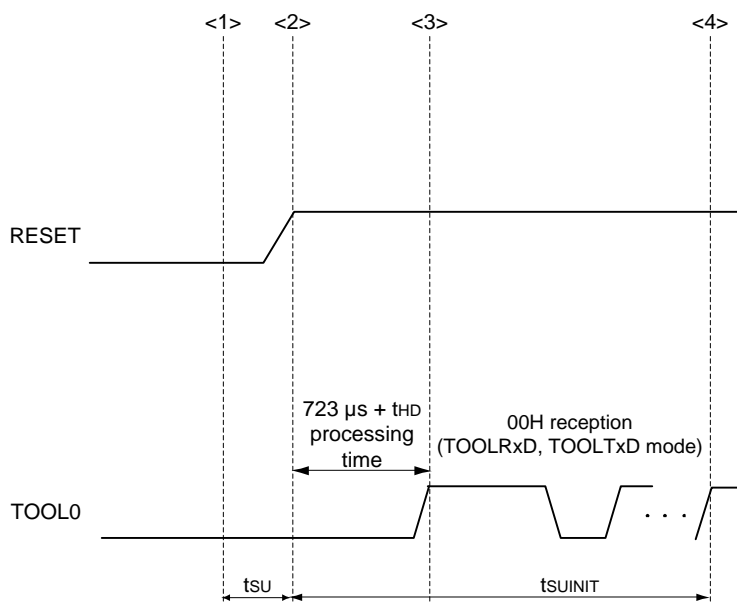

- <1> The low level is input to the TOOL0 pin.
- <2> The external reset ends (POR and LVD reset must end before the external reset ends).
- <3> The TOOL0 pin is set to the high level.
- <4> Setting of the flash memory programming mode by UART reception and complete the baud rate setting.

**Remark** tsuINIT: The segment shows that it is necessary to finish specifying the initial communication settings within 100 ms from when the external resets end.

tsu: Time needed for the TOOL0 pin is placed at low level until the pin reset ends

tHD: Time needed for the TOOL0 pin at low level from when the external resets end  
(excluding the processing time of the firmware to control the flash memory)

## 5. DETAILED DESCRIPTION

### 5.1 Overview

RAJ240090 / RAJ240100 are Renesas fuel gauge ICs which consist of a MCU block and an AFE block in a single package and accomplish various protection mechanisms. These IC's incorporates advanced battery management features such as primary and secondary protection, voltage and current measurement, current integration, host communication interface. By using the battery management controlled firmware and data are stored in the embedded flash memory to control the embedded analog and digital hardware circuits, optimum battery management operation including high accuracy remaining capacity estimation and battery safety can be achieved.

### 5.2 System block diagram

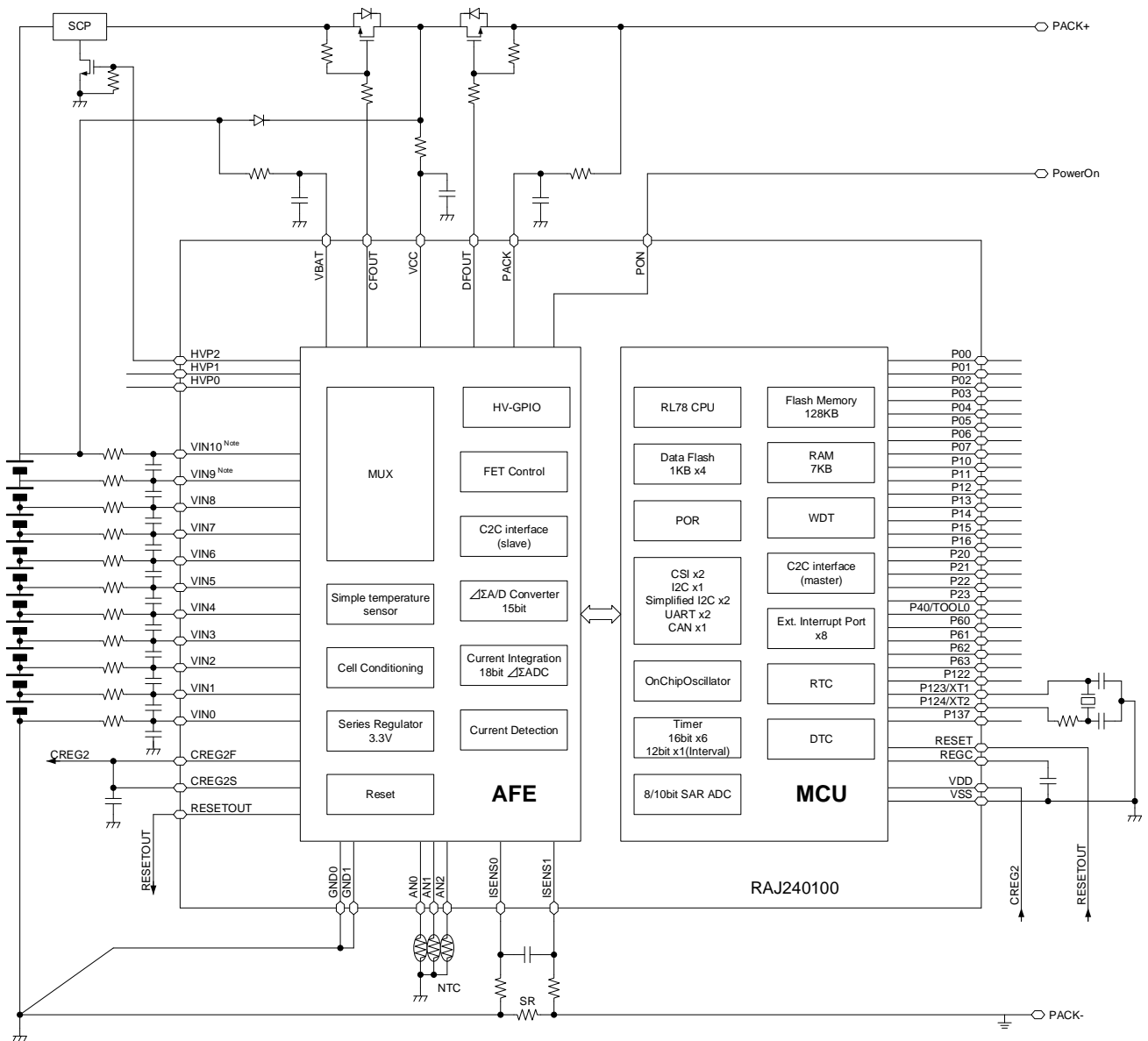

**Note** VIN10 pin and VIN9 pin are only applicable to RAJ240100.

**Caution** The example peripheral circuit does not guarantee proper operation. Please perform sufficient evaluation using the actual application to determine the circuits and peripherals.

### 5.3 MCU block diagram

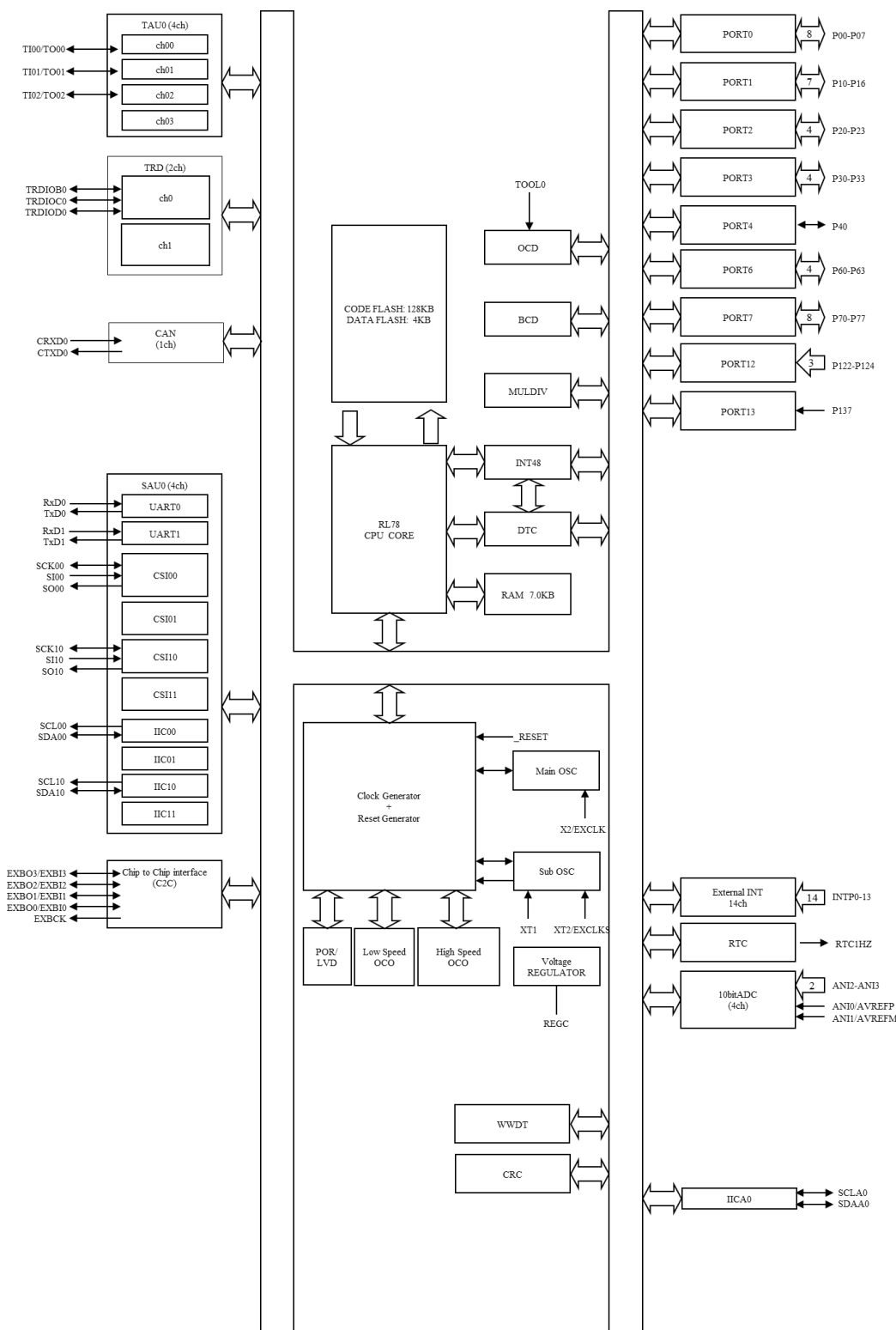

- Caution 1.** P30, P31, P32, P33, P70, P72, P73, P74, P75, P76 and P77 are connected to the internal AFE chip and not connected to the package external pins.
- Caution 2.** Each interrupt request of AFE is assigned to P30/INTP13, P31/INTP12, P32/INTP11, P33/INTP10, P70/INTP9 and P71/INTP8.



## 6. APPLICATION GUIDELINE

### 6.1 Typical Application Specification

A typical specification example of Li-ion battery management unit as shown below.

From the next page, the typical application guideline is explained for RAJ240100 (10 series cells application).

Battery cell assembly : 8S1P (8 cells in series and 1 cell in parallel) for RAJ240090

: 10S1P (10 cells in series and 1 cell in parallel) for RAJ240100

Host interface : System Management Bus (SMBus) Specification, version 1.1.

: UART

: CAN

Primary protection : charge FET and discharge FET

Secondary protection : Fuse blow by FGIC (RAJ240090 and RAJ240100) or a secondary protection device.

Connector pins:

Pack+ Positive battery pack terminal

SCL SMBus clock

SDA SMBus data

CANH CAN high

CANL CAN low

UART UART communication port

PON High voltage port for battery power on

Pack- Negative battery pack terminal

External reverse charge protection circuit

Battery and charge/discharge MOSFET temperature measurement with three thermistors



### 6.3 Circuit Design Guideline

#### 6.3.1 Cell voltage monitor circuit

- Place an input filter between FGIC's VINx port and each of the cells.
- Place resistors valued around 100 Ω and capacitors valued around 0.1 uF to VIN1 – VIN10 for surge protection. It is necessary to calculate the cut-off frequency and use correct resistance and capacitance value based on application.

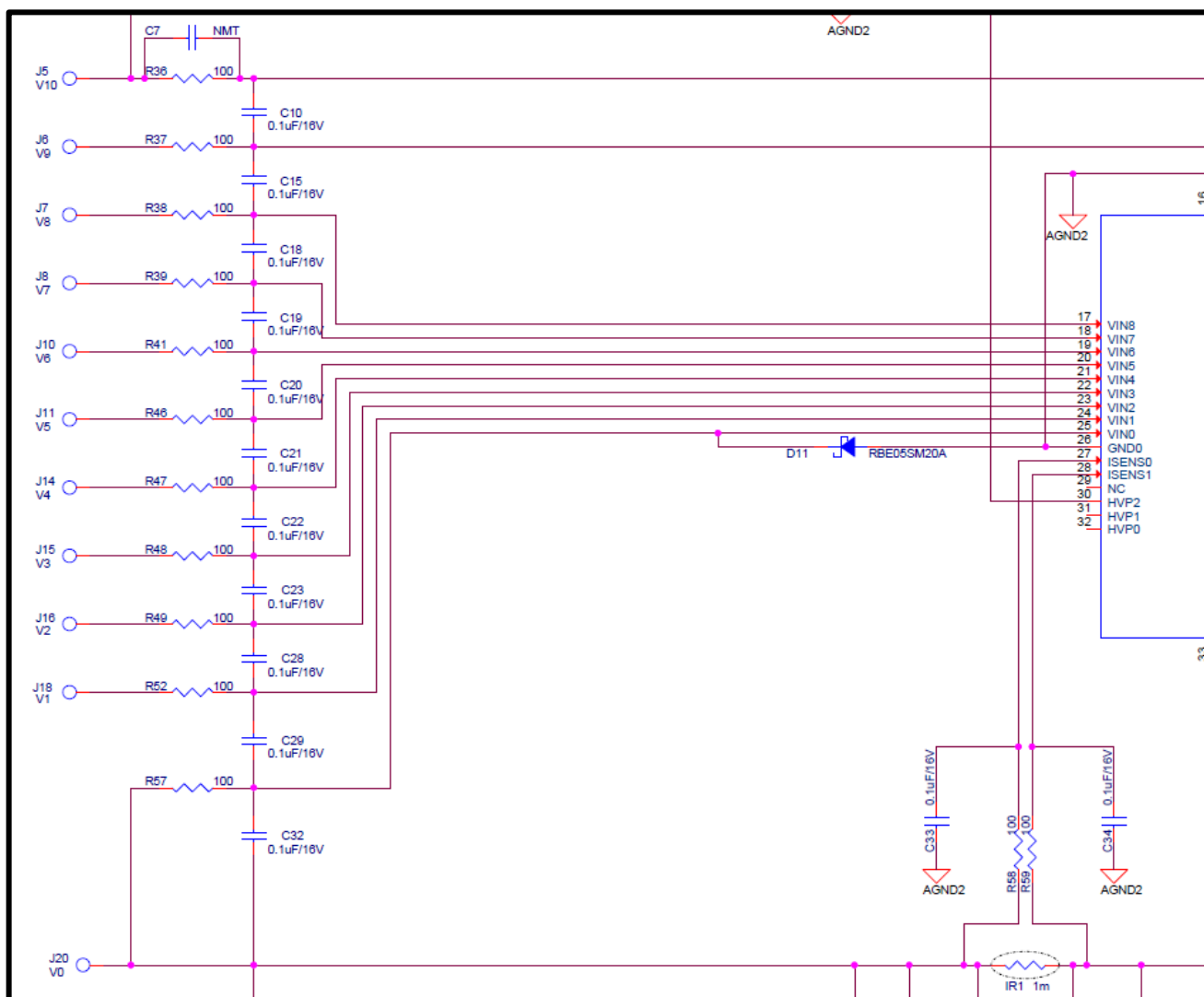

### 6.3.2 Battery power on circuit

- Place resistors value around 2 kΩ (1 kΩ+1 kΩ), capacitor 0.1 uF and zener diode to PON for surge protection. It is necessary to calculate cut-off frequency and use correct resistance and capacitance value based on application.

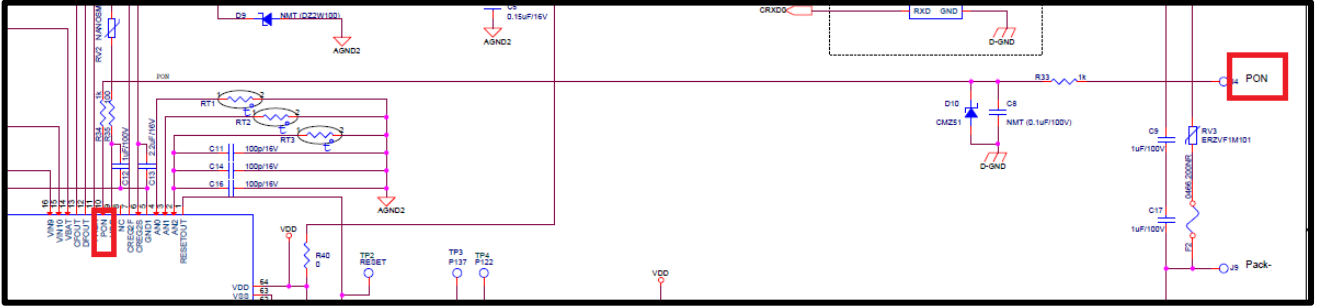

### <R> 6.3.3 PACK port

- PACK port is source voltage of DFOUT (D-FET gate control signal). R12 plays a role in limiting the current limit when charger is reverse-charged. 1 kΩ is recommended, if it is too large, the D-FET turn off speed will become too slow.
- C3 helps provide stable D-FET boost operation. 0.1 μF is recommended. If any problems occur in short circuit protection or ESD etc., adjust the value of C3.

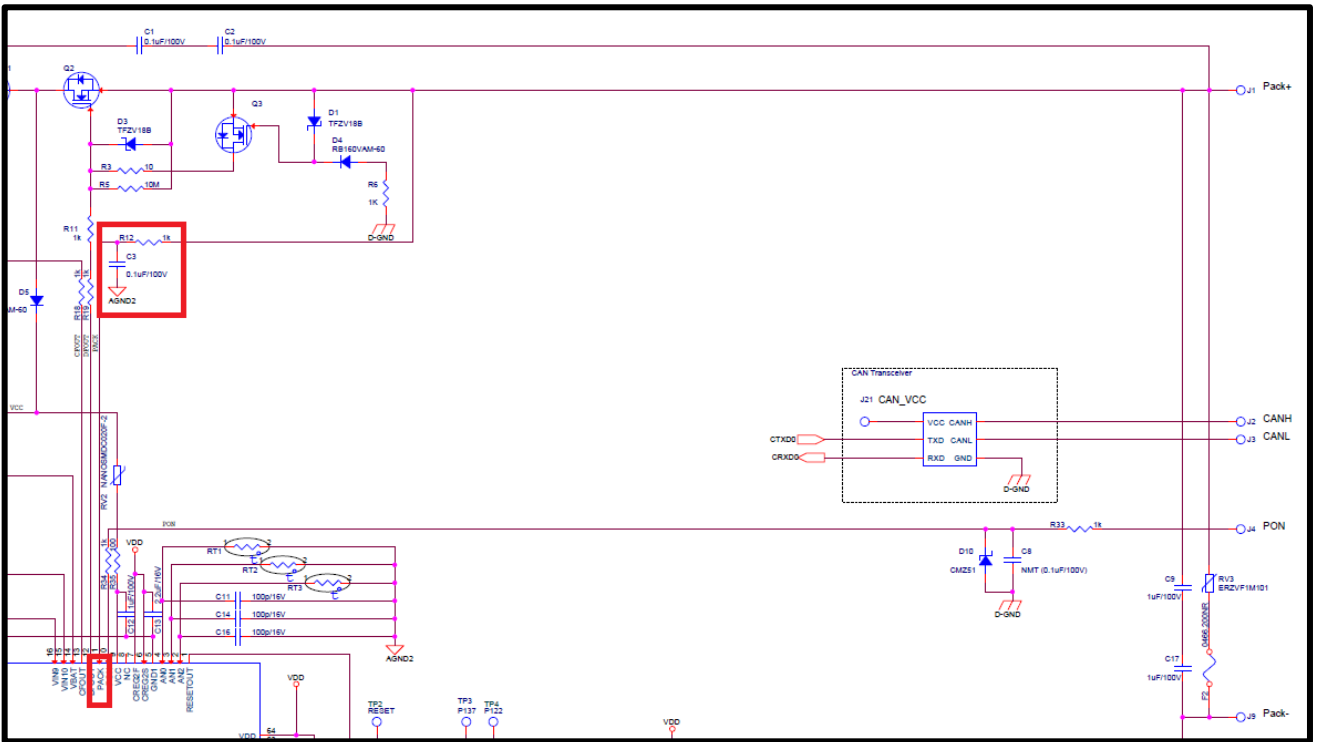

### 6.3.4 Current monitor

- Potential difference on the sense resistor is monitored by current integration circuit.
- Place a Low Pass Filter (100 Ω, 0.1 μF) at input stage.
- Sense lines should be shielded if small voltage difference is detected to ensure high accurate current sensing.

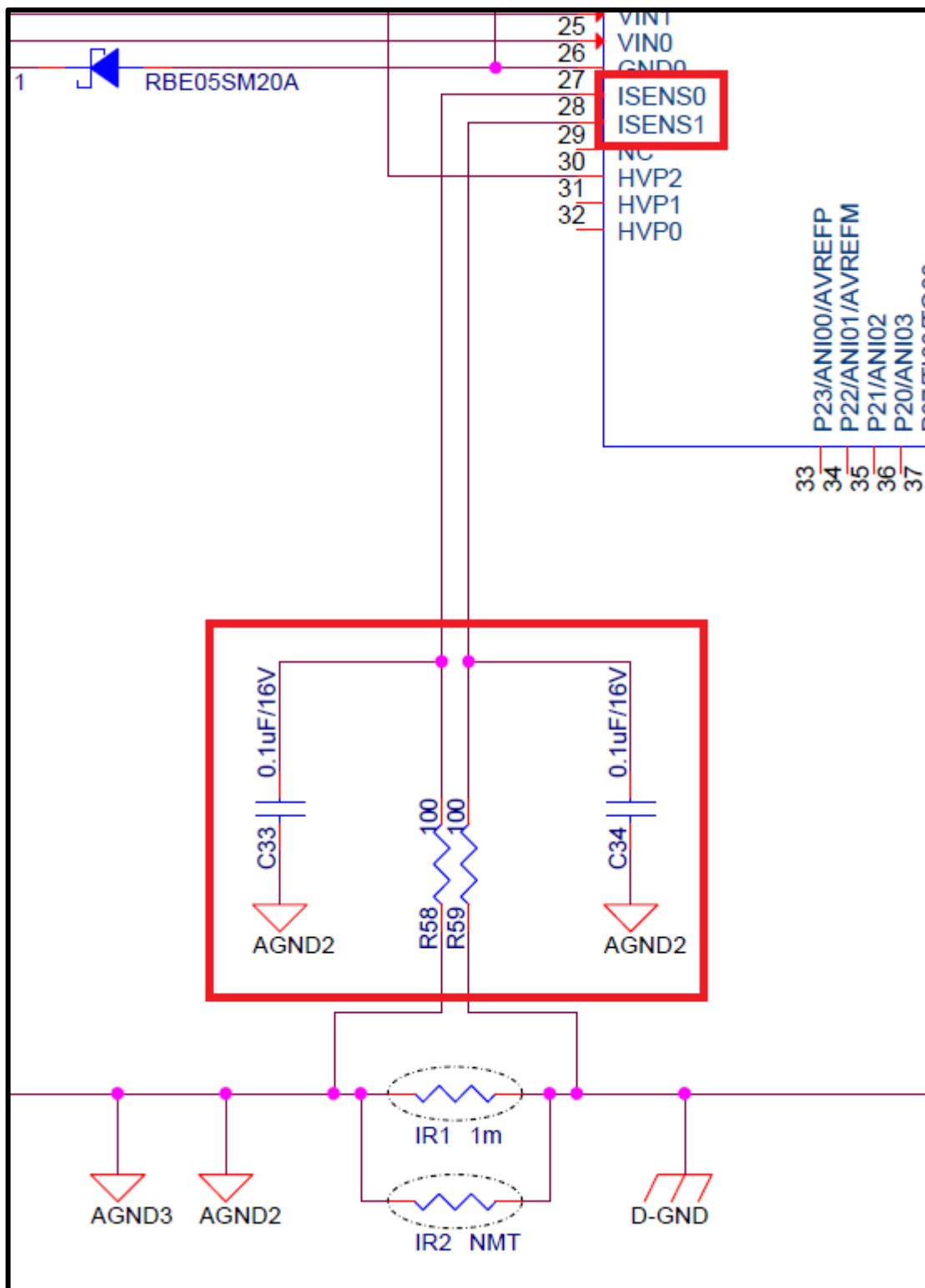

### 6.3.5 Fuse control

- Self-control protector (SCP) is used for fuse in reference circuit.
- The fuse will blow when RAJ240100 drives HVP2 (High voltage GPIO) pin high to make Q4 ON.
- The fuse will blow when overcurrent exceeds the limit of SCP.
- R1~R2 and R7~R9 are used for battery electrochemical migration short circuit countermeasures.

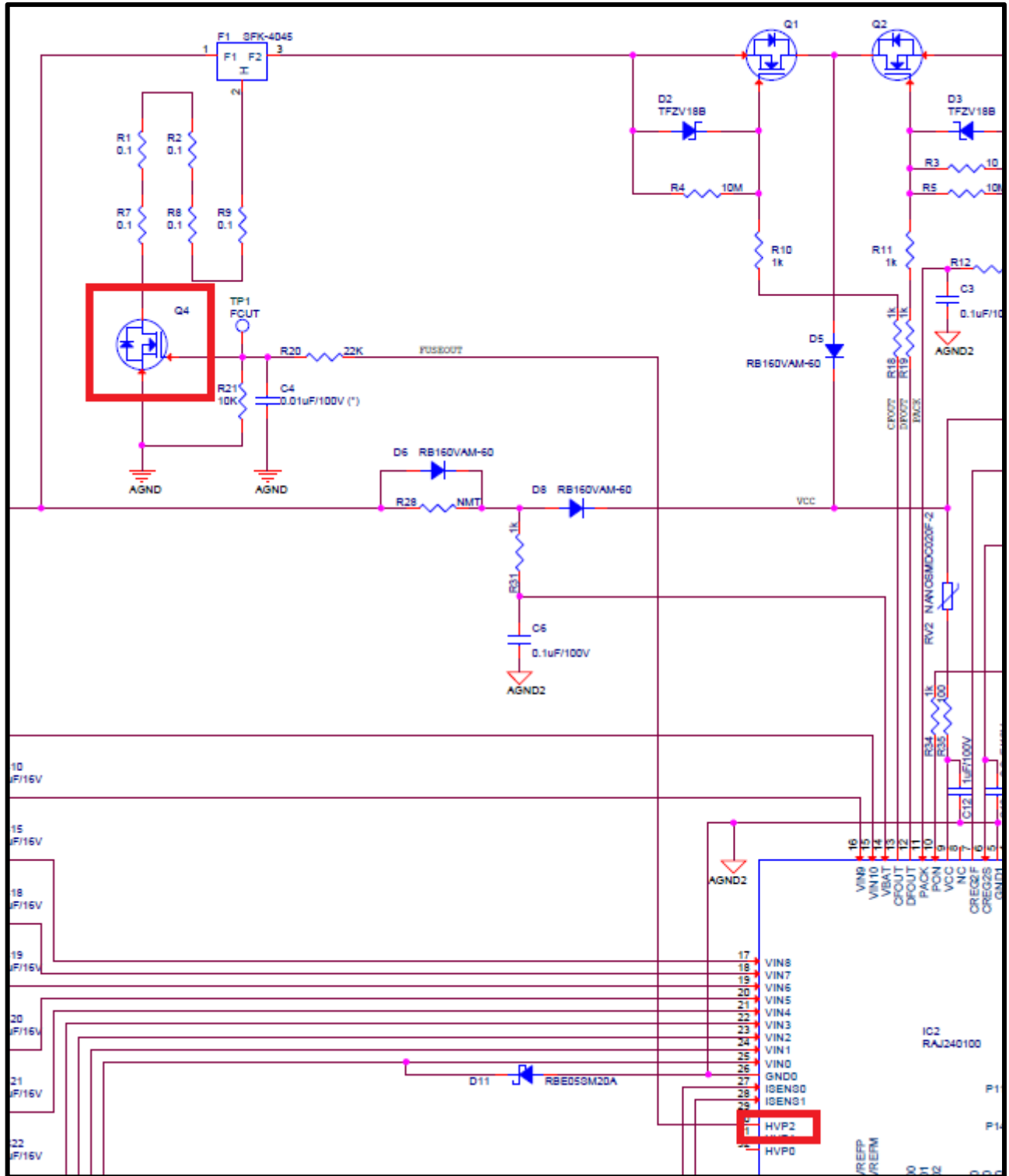

<R> **6.3.6 C-FET and D-FET control**

- Q3 is located between gate and source of Q2 to make D-FET turn off when charger is reverse connected.
- R6 is for Q3 gate protection. (1 kΩ is recommended.)
- R10, R11 and R18, R19 are use as gate protection and C-FET/D-FET noise reduction. (1 kΩ each is recommended.)
- R4 and R5 are used to fix C-FET/D-FET gate voltage in order to keep stable off state when FET is turn off. 10 MΩ is recommended to prevent voltage drop.

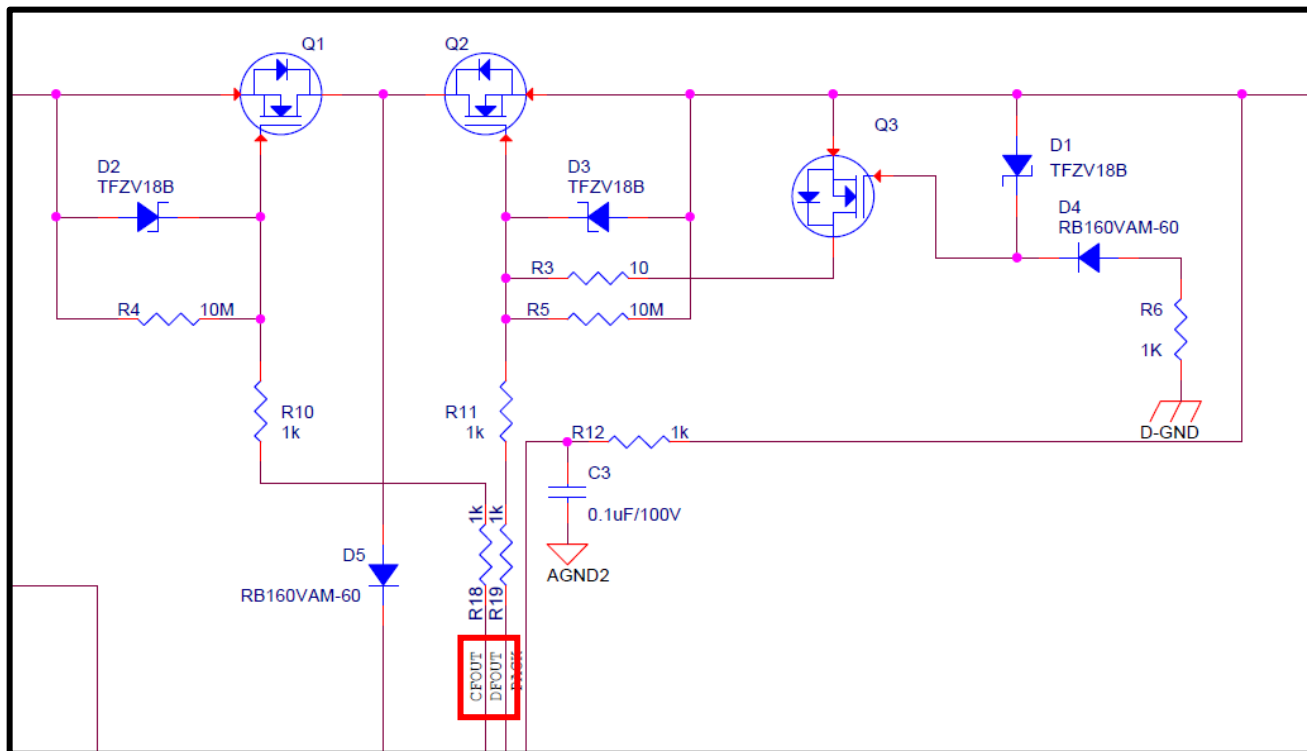

<R> **6.3.7 Thermistor**

- ADC voltage measurement pins (AN0, AN1, AN2) are assigned for thermistor. To prevent EMC noise issue, additional 100 pF capacitor is recommended.

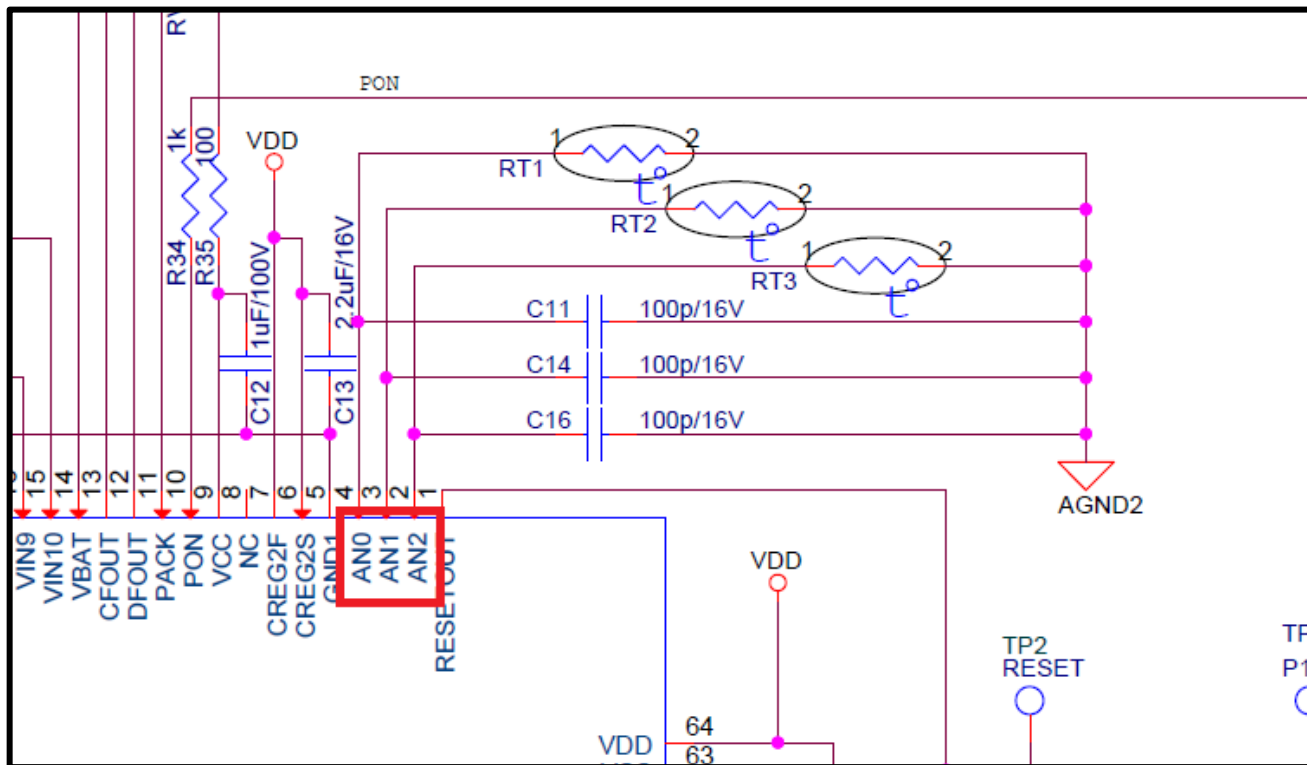

<R> **6.3.8 Communication line**

- RAJ240090 / RAJ240100 support 3 kinds of communication, SMBus, UART and CAN.
- For electrical over stress countermeasure, input 200 Ω, 330 Ω resistance, zener diode and capacitance (NMT) are recommended in SMBus communication line.
- For UART communication, it is necessary to add the circuit with appropriate protection by user's UART protocol. P11 and P12 pins have VDD output circuit, therefore RXD/TXD line pull up voltage should be the same as VDD.
- CAN communication can be used by adding CAN transceiver externally. It is necessary to adapt external power supply for CAN transceiver. The internal CREG2 supply cannot be used for CAN transceivers power supply because it is not enough for CAN transceivers current consumption, so the external power supply or the external CREG2 output option (6.3.11 External CREG2 output option) are recommended. For the external circuit of CAN transceiver, please refer to the specification sheet / manual of the CAN transceiver.

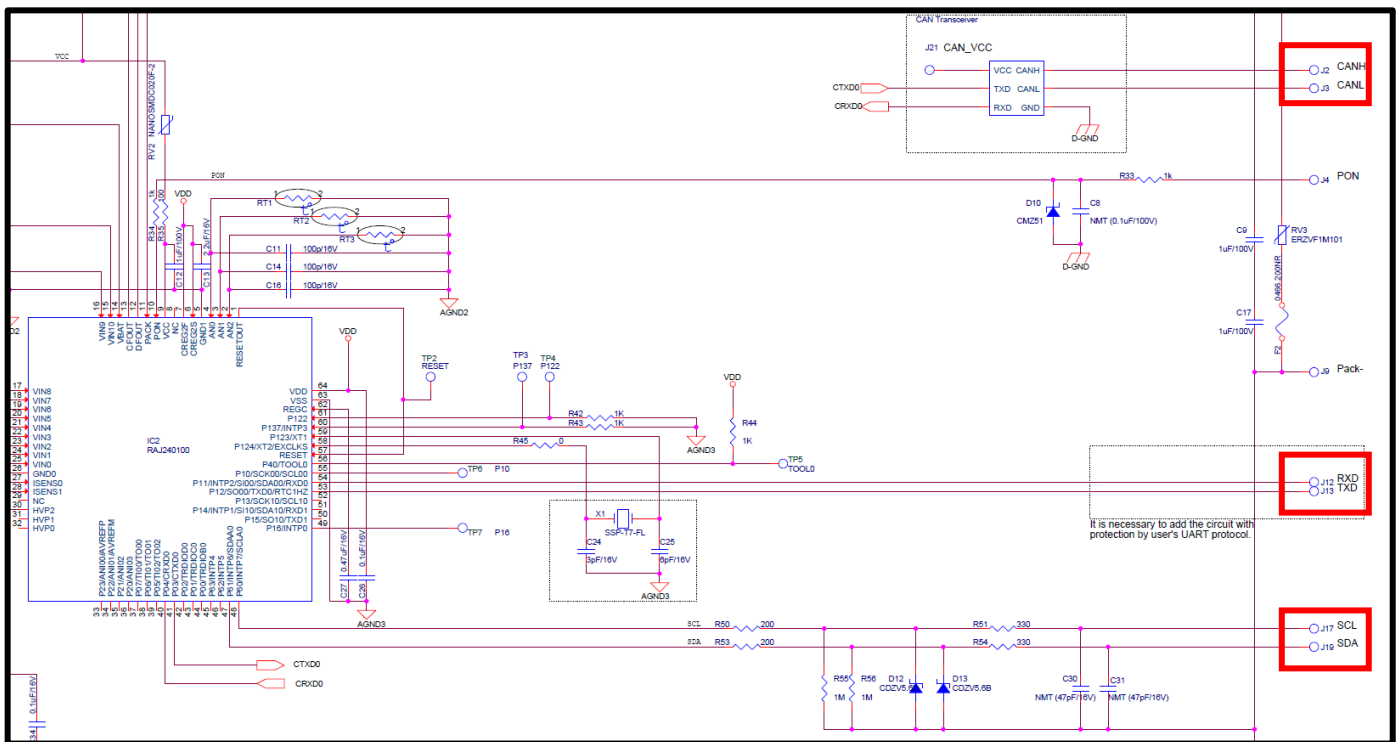

### 6.3.9 Power supply path

- Power is supplied to VCC through the following two paths depending on circumstance.
- Power is supplied from battery side when Pack+/- is not connected to a charger or the fuse is blown. See power supply line 1.
- Higher output voltage from battery and charger is used as power supply. See power supply line 2.
- For protection of the VCC pin, it is recommended to add resistor 100 Ω and PTC for current limit.

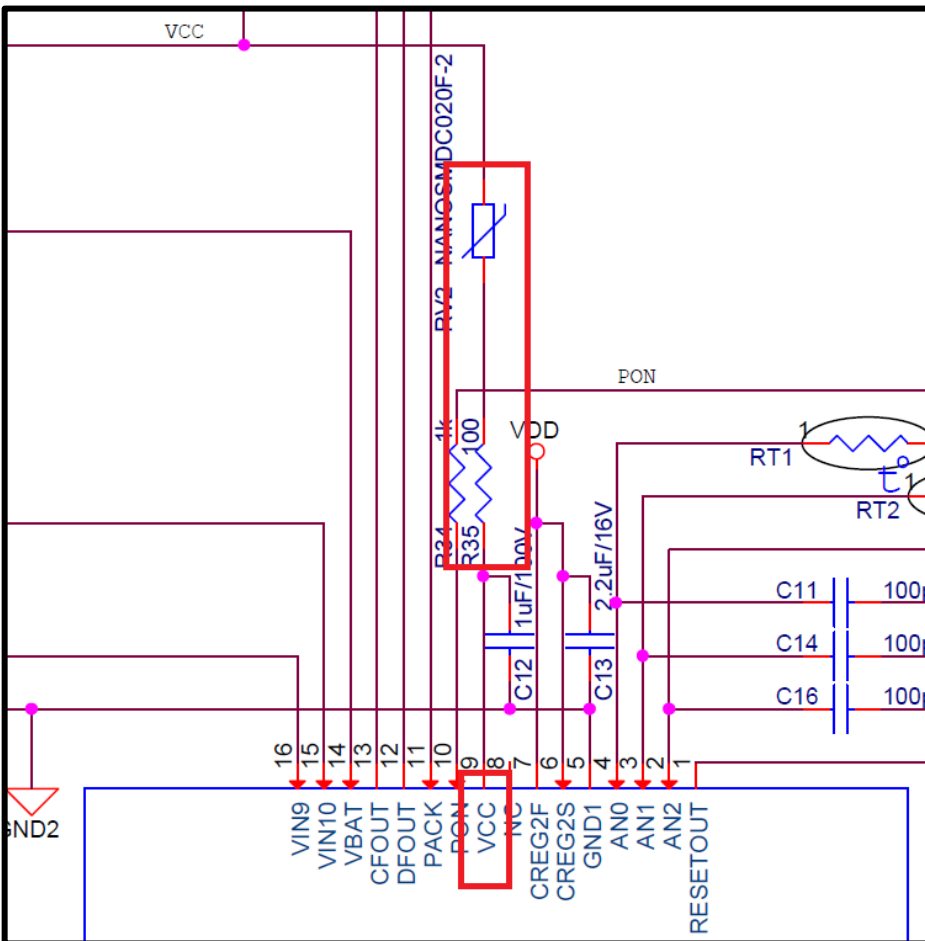
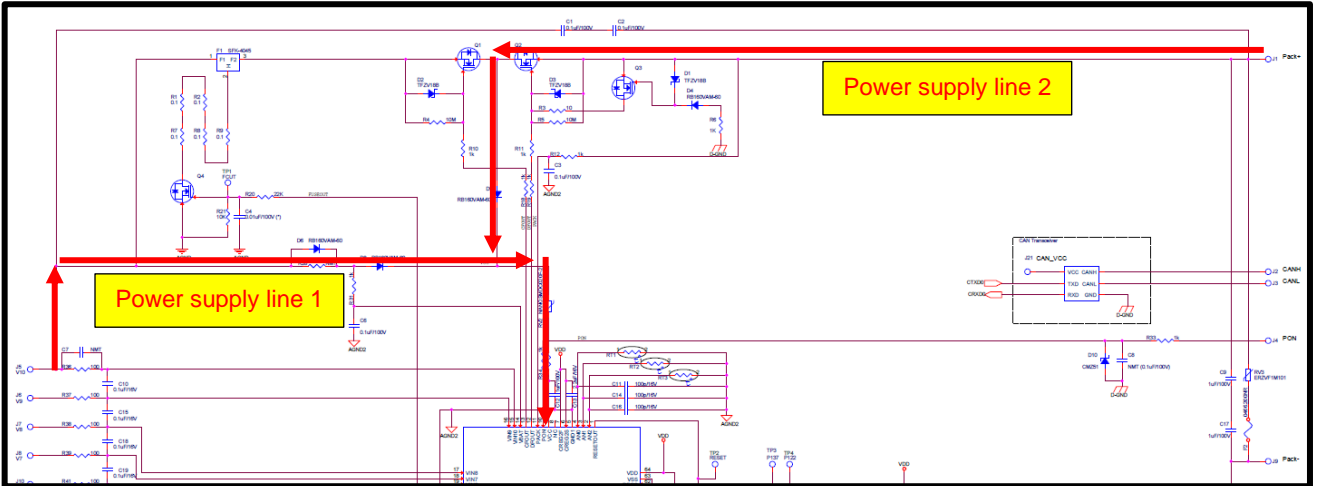

### 6.3.10 VCC, CREG2S, VDD and REGC capacitance

- The following decoupling capacitors must be located adjacent to each terminal.
- C12: VCC (1  $\mu$ F is recommended.)
- C13: CREG2 (1 to 4.7  $\mu$ F is recommended.)
- C26: VDD (0.1  $\mu$ F is recommended.)
- C27: REGC (0.47 to 1  $\mu$ F is recommended.)

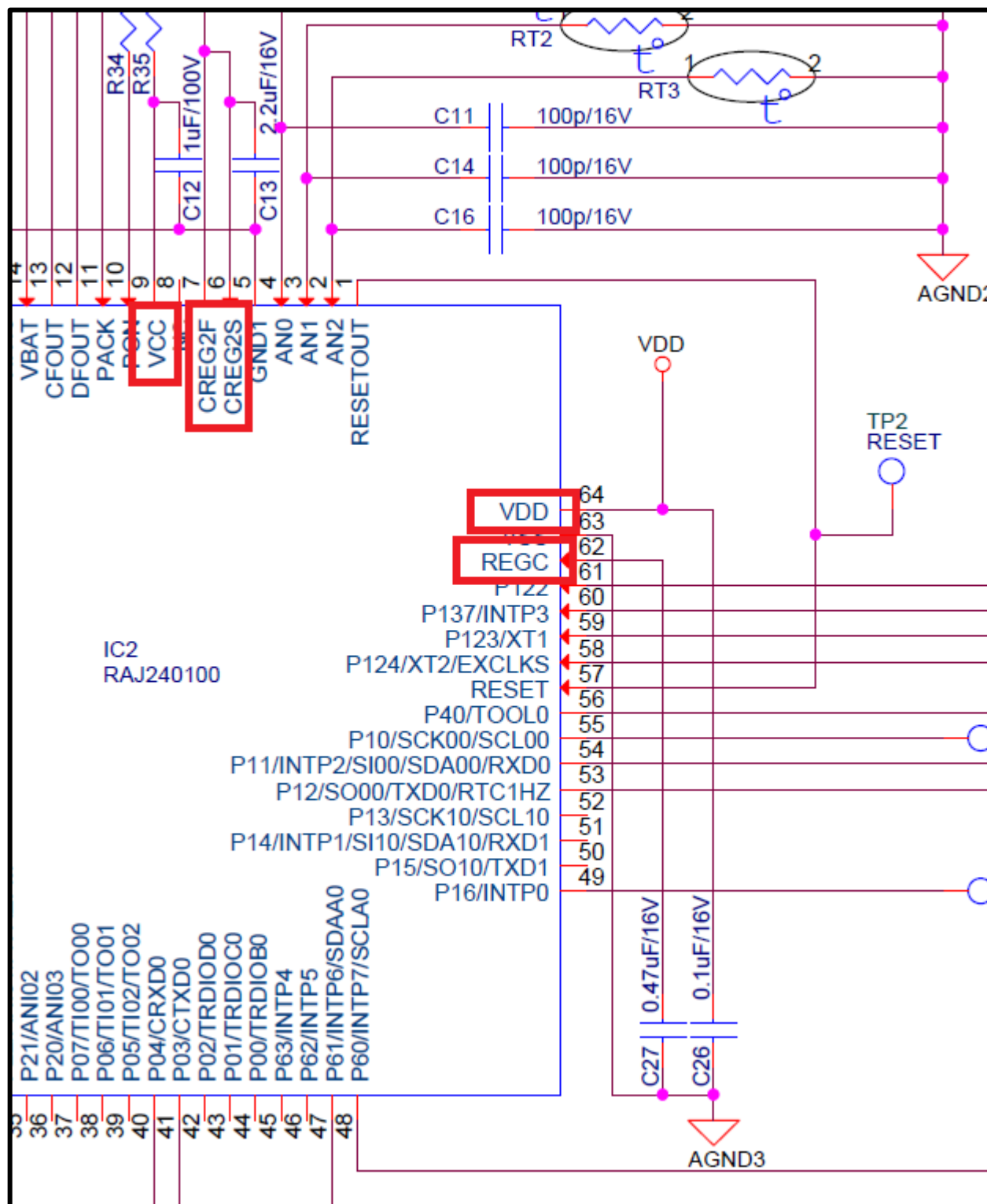

<R> **6.3.11 External CREG2 output option**

- The external CREG2 output option enables more high current output. The example of external CREFG2 drive circuit is as below. Q5 regulates from VCC (max 42 V, 4.2 V / cell x 10 cell) to 5 V, so heating issue and migration are concerned. R13~17, R22~26 and RV1 are countermeasures to migration short. And also it helps for heat dissipation to consider the layout design for the Q5. D7 is gate-source protection for Q5. R32 and C5 should be adjusted depending on Q5 specification. CREG2 output should be connected to VDD.

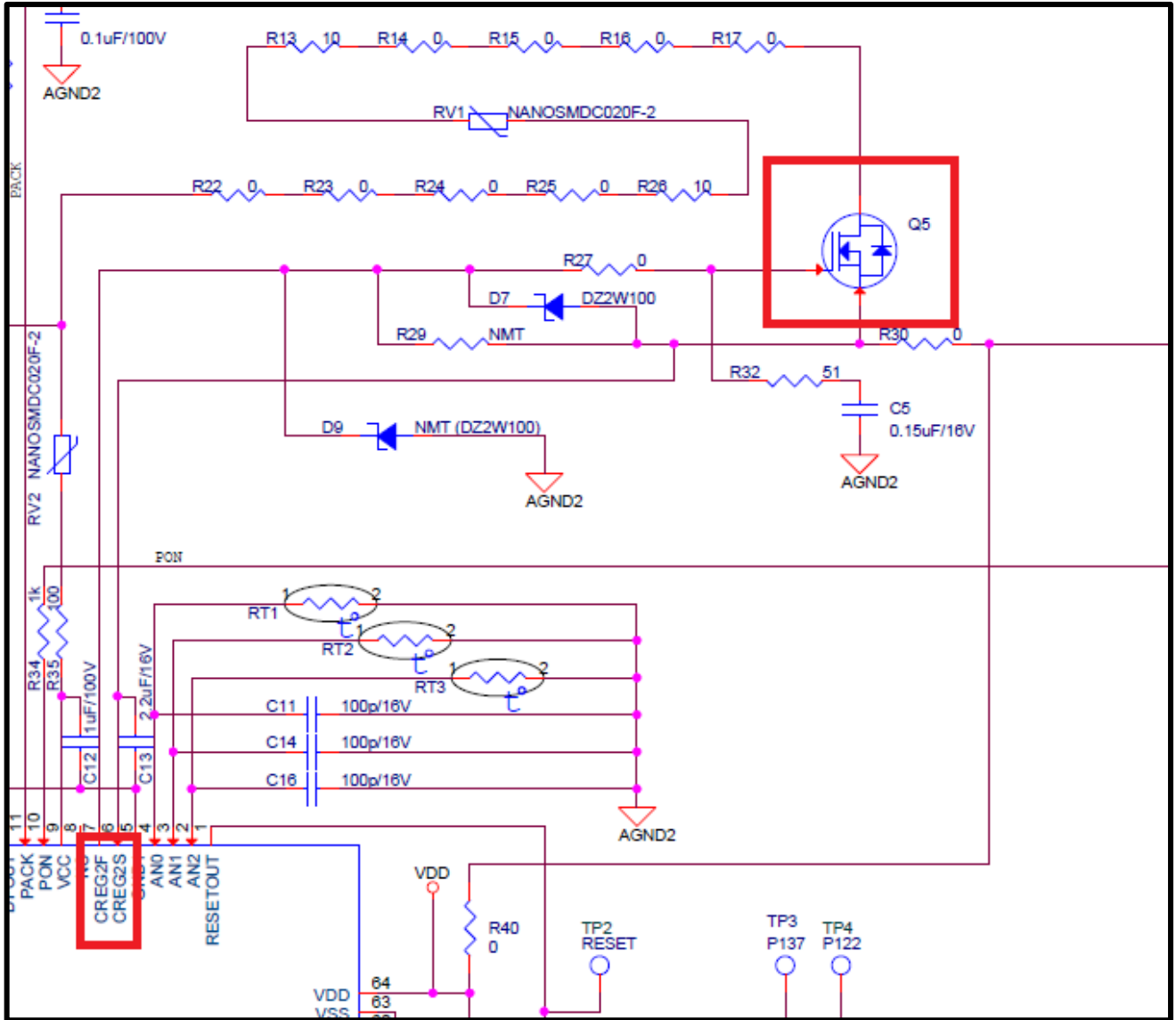

<R> **6.3.12 Crystal oscillators port XT1 and XT2 for RTC**

- RAJ240090 / RAJ240100 support RTC (Real time clock).
- XT1 and XT2 are used for an external crystal oscillator's port. It is recommended to set the XT1 and XT2 line length as short as possible.
- Shield pattern is necessary to XT1 line.

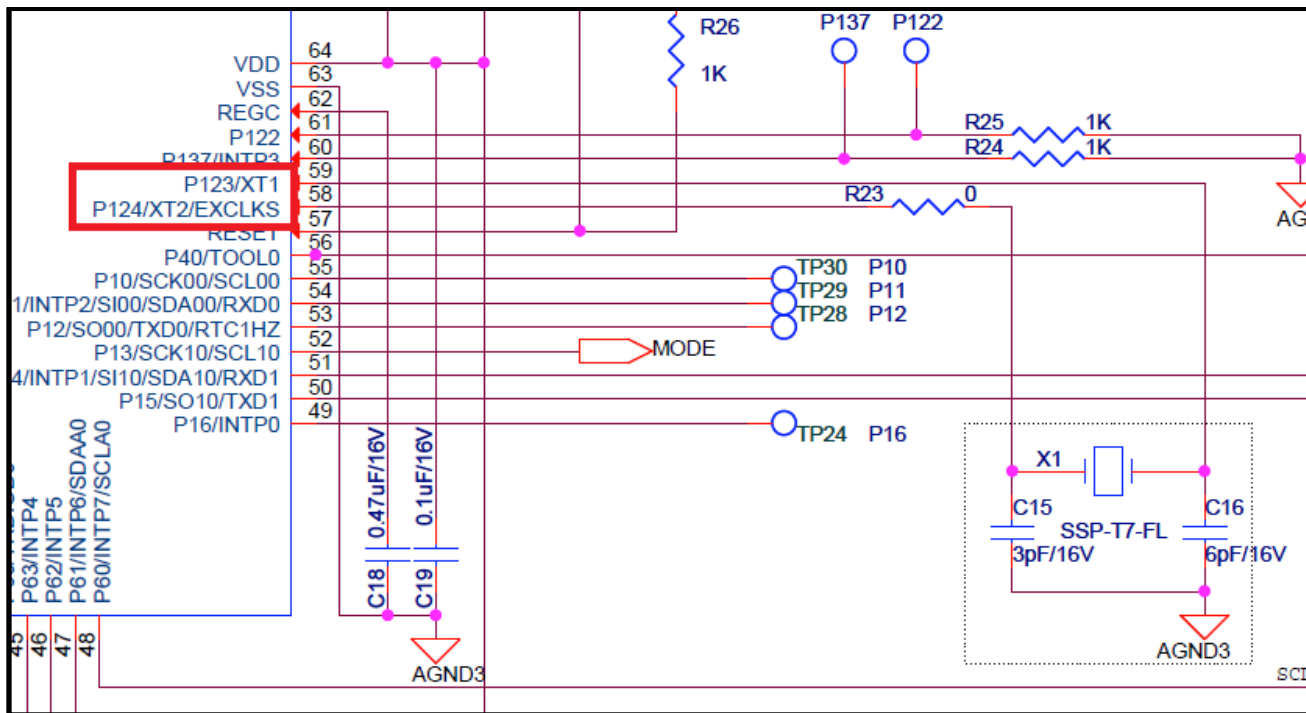

## 6.4 Layout Guidelines

### 6.4.1 Summary

- Large current patterns must be wide and short to minimize voltage drop and heat generation.
- Bypass capacitors must be mounted as close as possible to the device VCC / VBAT and GND pins to prevent erroneous operation due to noise from power supply.
- Capacitors for voltage regulators must be located close to regulator pins to ensure loop stability and ESD tolerance.
- All IC ground must be connected to the negative terminal of battery cells except ground for communication lines.
- Communication lines must be away from small signal current sense line to prevent the input signal from being disturbed by the incoming radiation noise.
- FGIC (RAJ240090 and RAJ240100) must be located away from any heat source (FET, current sense resistor and large current patterns) to minimize the influence of heat.

### 6.4.2 ESD protections on each terminal (basic policy)

- ESD on Pack+ terminal must be discharged to the top side of the cell or to Pack- terminal through a capacitor.
- ESD on Pack- terminal must be discharged to the GND side of the cell.
- ESD on communication terminals and other GPIOs must be discharged to the GND side of the cell via Pack- terminal.
- The noise from PACK+ or PACK- must be discharged to the battery cells so that it will not interfere with FGIC functions and measurements.

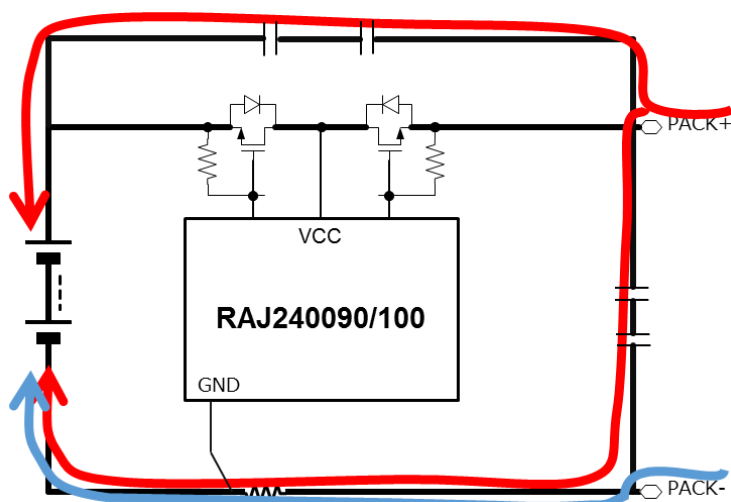

### 6.4.3 Pack+, Pack- (Noise protection element)

- A bypass capacitor must be placed between Pack+ and Pack-. (Countermeasure against ESD)
- A bypass capacitor must be located adjacent to Pack+, Pack-. (Minimize the ESD influence)
- Capacitors must be placed in series. (Countermeasure against short-circuit of capacitors)
- Don't use tantalum capacitor. (Tantalum capacitor can end up with short-circuited failure when damaged.)
- For the terminal protection against noise and overvoltage, it is recommended that it carries varistor or TVS diode.(RV3)
- It is recommended to add Fuse to prevent short circuit.(F2)
- C9, C17, RV3, F2 must be placed as short as possible between PACK + and PACK-. However, be careful not to narrow the distance between Pack + and Pack-.

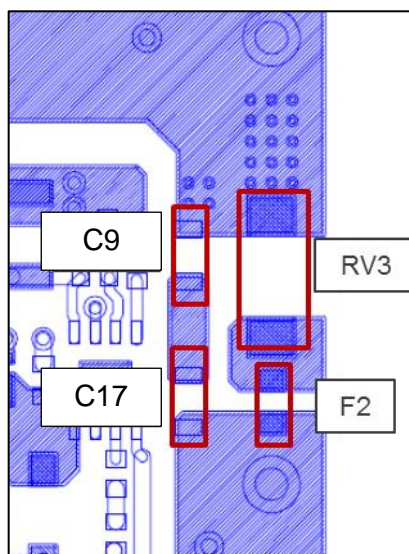
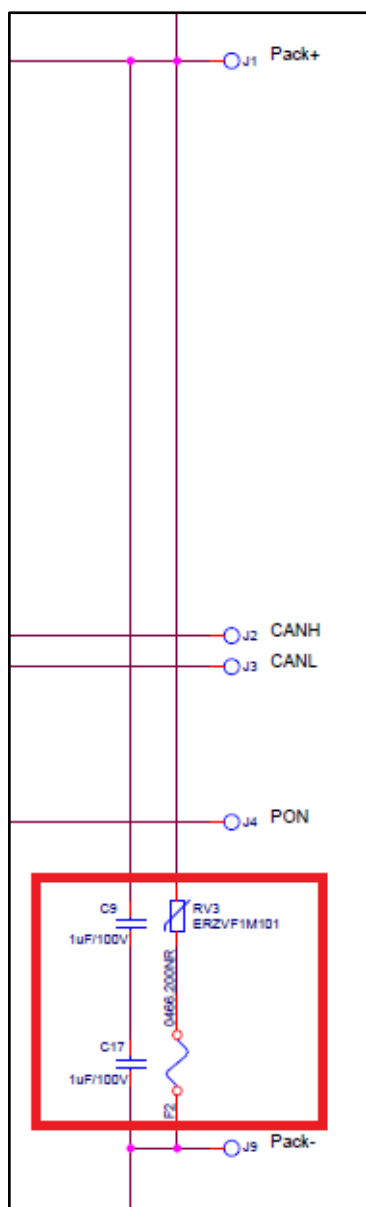

### 6.4.4 GND connection

- Each analog GND of FGIC should be connected to the point (A) of current detection resistor of the cell side by the pattern with an adequate width. (Prevent potential variation by large current.)
- VIN0 should be connected near point V0 (B).
- The patterns between AGND, AGND2 and AGND3 must not be divided. (Keeping the GND potential of MCU and AFE equal)

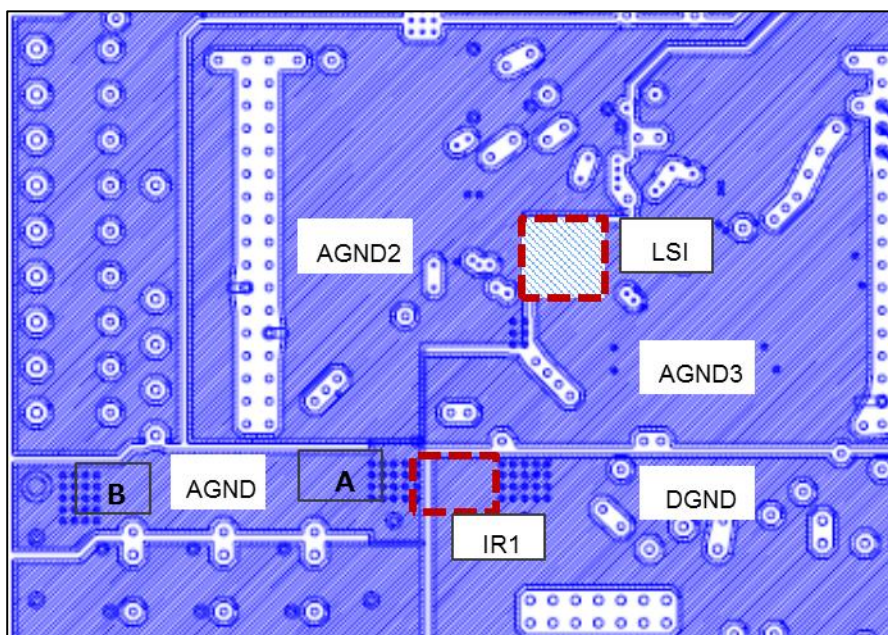
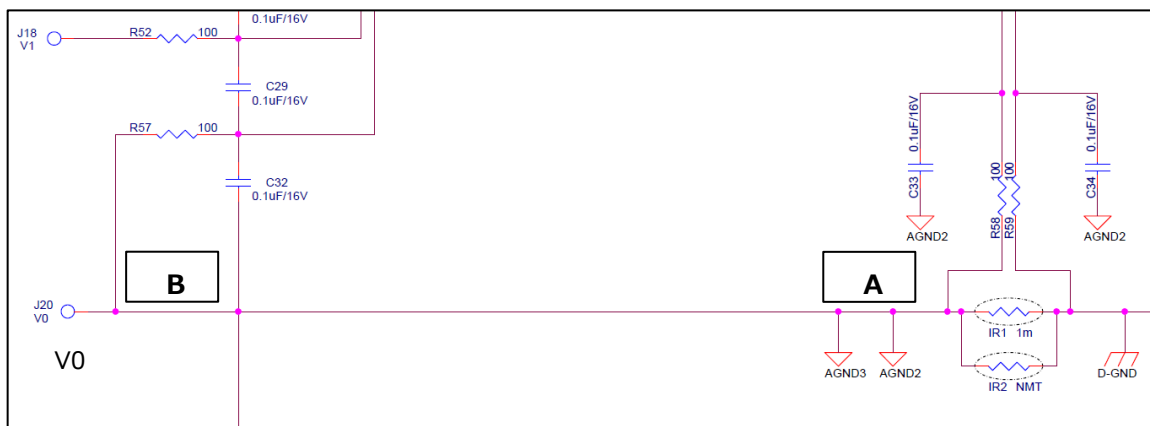

### 6.4.5 Bypass capacitor between VCC/VDD/CREG2S/REGC and GND1/VSS

- The patterns between VCC/CREG2S pin and GND1 pin, and VDD/REGC pin and VSS pin, a bypass capacitor is connected and the path must be as short as possible. (Countermeasure for ESD)

The FGIC and bypass capacitor must be placed on the same side of the PCB without through-holes and the maximum loop length must be about 20 mm.

- The lines to bypass capacitor must be wide and short. (To keep bypass capacitor effective in suppressing the potential variation.)

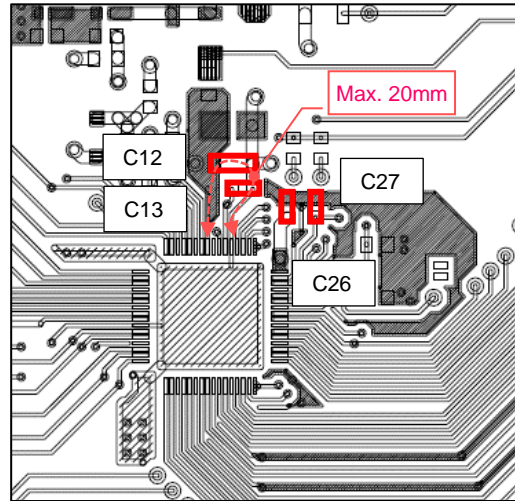
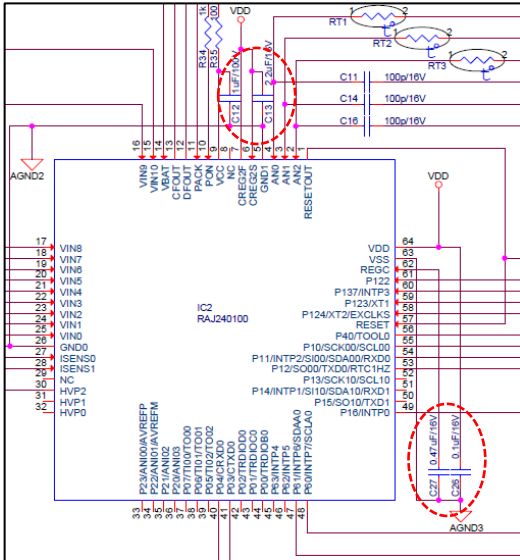

### 6.4.6 Current Monitor (ISENS0, ISENS1)

- Two lines from current sense resistor to ISENS0, ISENS1 must be the same in width and length, and in parallel with the same space between the two lines. (Prevent erroneous detections due to noise)
- LPF (100 Ω and 0.1 uF) and a shield pattern should be placed to ISENS0/1 lines. (Countermeasure against noise)
- Minimizing wire length and its number of branches between current sense resistors and ISENS0/ISENS1 pins to suppress incoming noise from unnecessary pattern.

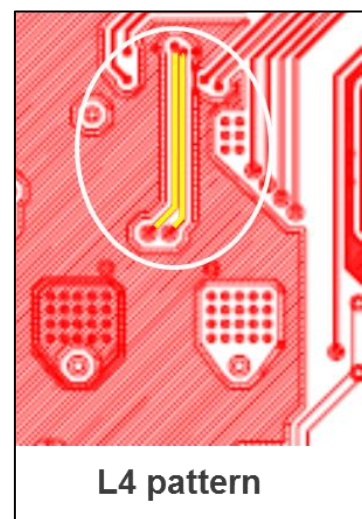
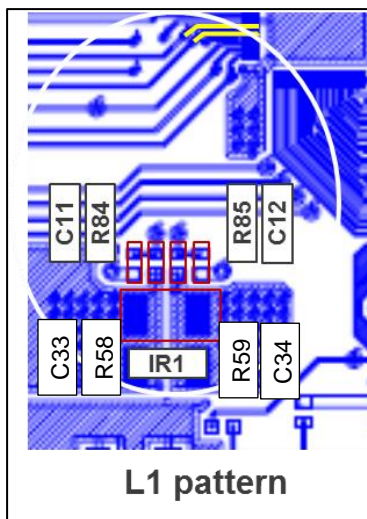
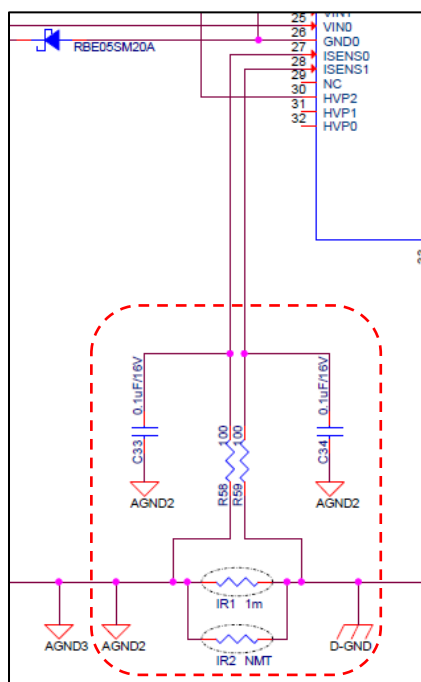

### 6.4.7 Communication line (SMBus)

- SMBus lines must be equipped with zener diodes. And it is necessary to mount resistors on the side of FGIC and pack connector. (Zener diode and the resistor on the side of connector are for surge countermeasures, the resistor on the side of FGIC for noise countermeasure.)
- The resistor on the side of the FGIC must be located as close to the FGIC as possible.

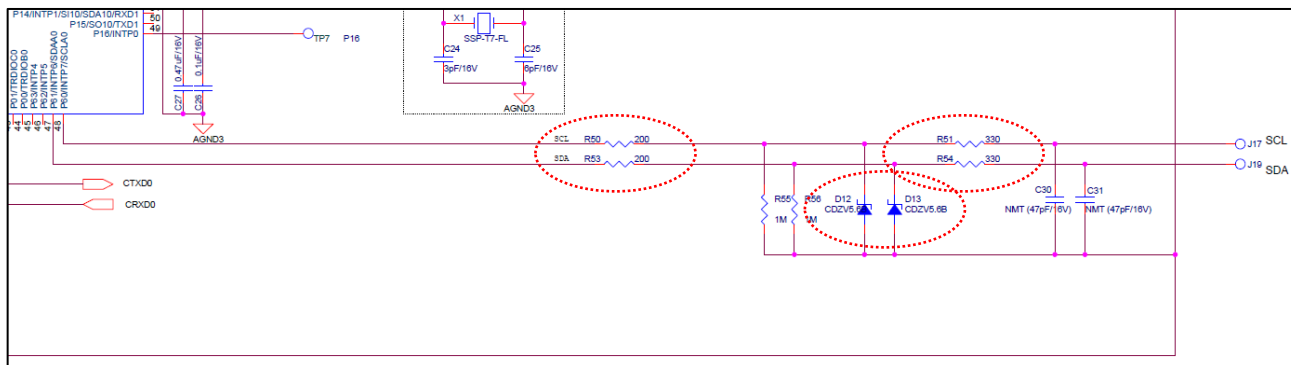

### 7. PACKAGE DRAWINGS

Caution These products have some assembly sites.

[FAB A]

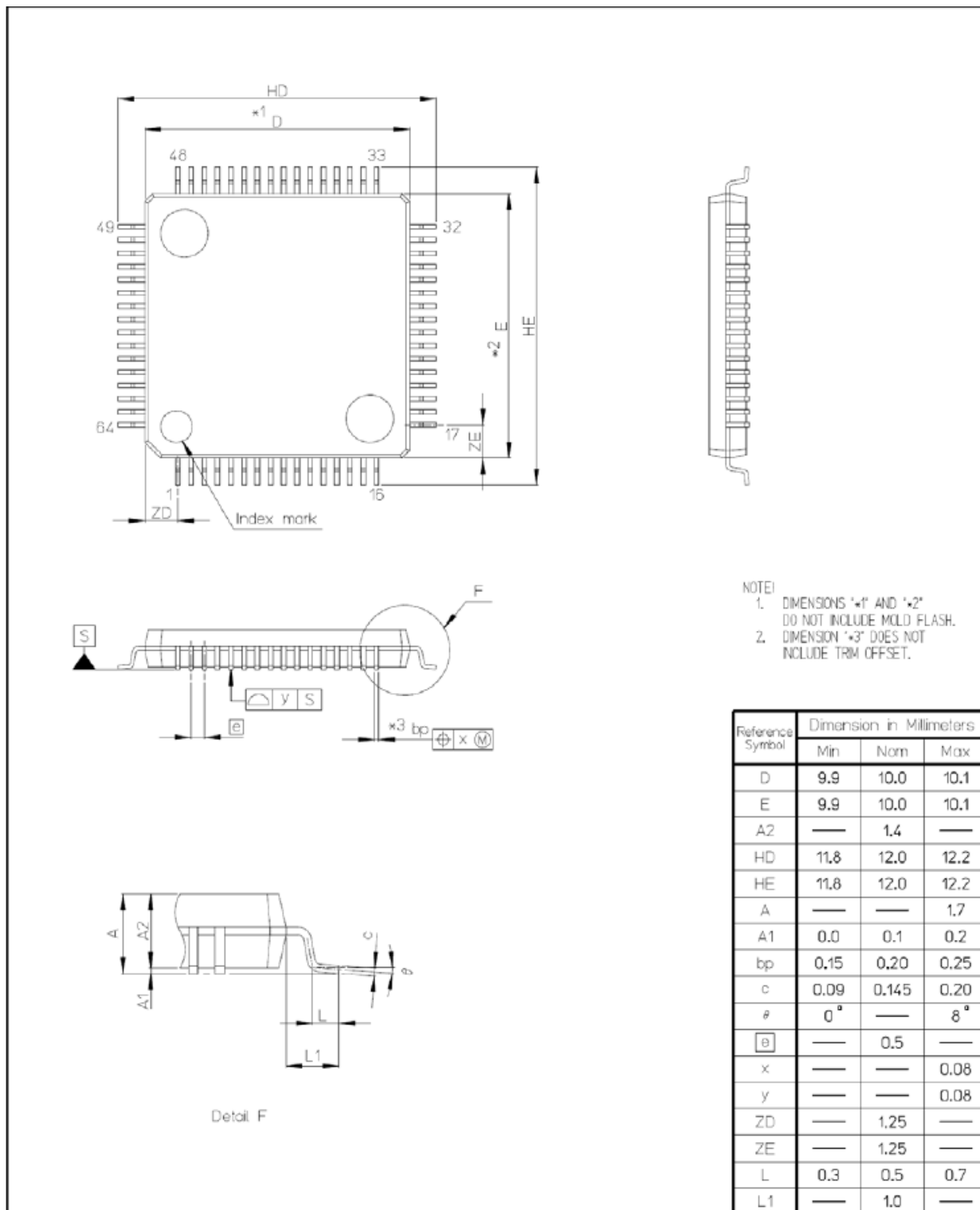

[FAB- B]

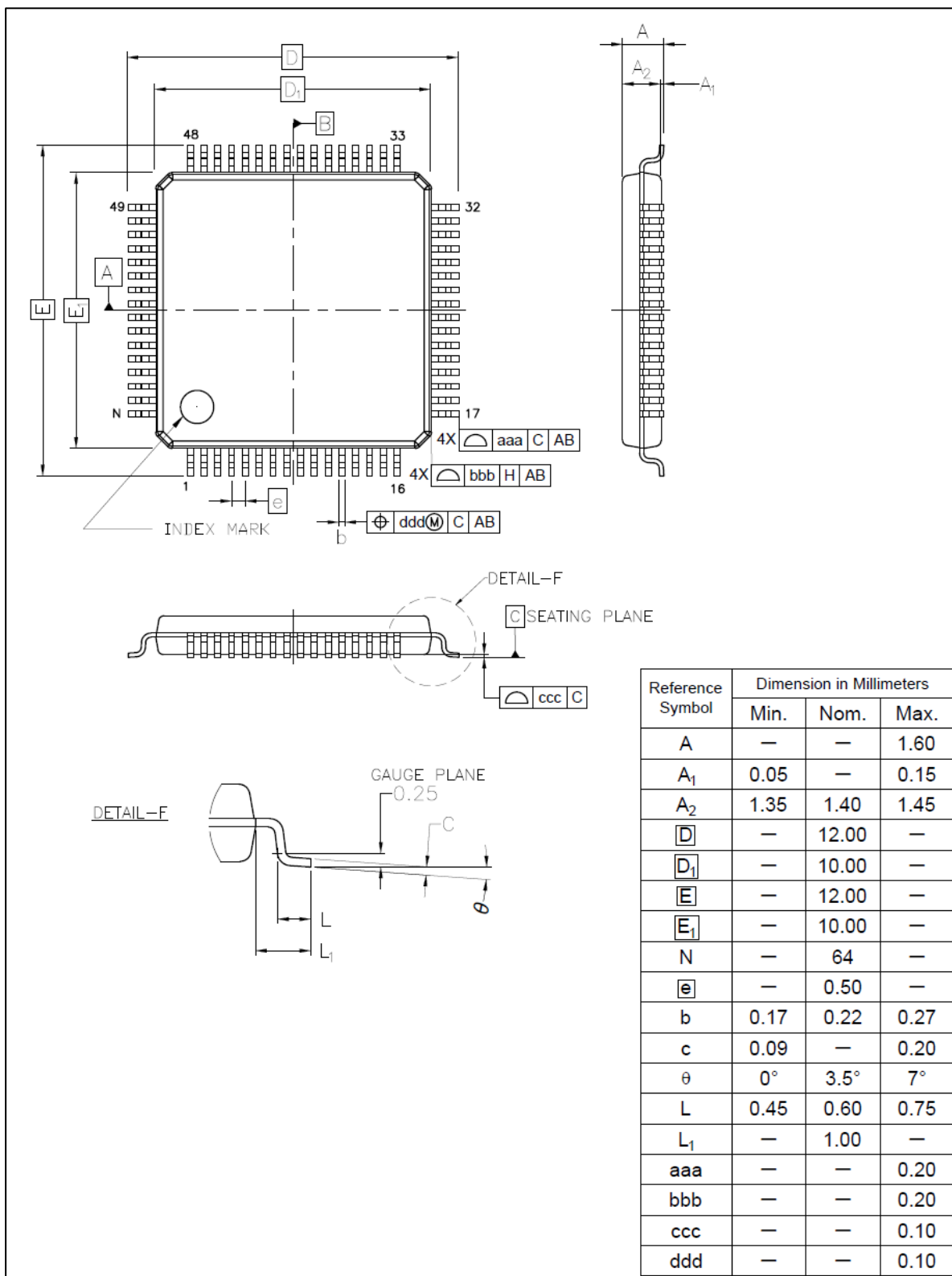

**REVISION HISTORY**

Rev.	Date	Page	Description
1.00	Nov 27, 2017		First Version()
2.00	May 10, 2018	p.1	1. Introduction Added description of Battery cell voltage and temperature (AN port voltage) detection circuit. Updated description for Operating ambient temperature (extend operating ambient temperature range). Added Note.
		p.4	2. OUTLINE Added description of Battery cell voltage and temperature (AN port voltage) detection circuit Updated description for Operating ambient temperature (extend operating ambient temperature range)
		p.22	4. ELECTRICAL SPECIFICATIONS Updated to extend operating ambient temperature range from (-20degC ~ +85degC) to (-40degC ~ +85degC) in RAJ240100.
2.01	Jun 7, 2018	p.62	5. Detailed description Updated figure of AFE block diagram
2.02	Sep 7, 2018	p.1	1. Introduction Updated description for Operating ambient temperature (extend operating ambient temperature range).
		p.4	2. OUTLINE Deleted Notes.
		p.22	4. ELECTRICAL SPECIFICATIONS Add Remark. Updated to extend operating ambient temperature range from (-20degC ~ +85degC) to (-40degC ~ +85degC) in RAJ240090.
2.03	Jan 17, 2020	P26	Added Note for 4.3 Supply current characteristics
		P80	6.4.5 Bypass capacitor between VCC/VDD/CREG2S/REGC and GND1/VSS Added description about bypass capacitor pattern
2.04	Jan 25, 2021	P68	6.3.3 Pack port Updated description of the external capacity of the Pack port. Updated figure
		P71	Updated figure
2.05	Sep 8, 2023	P83	Added the package outline

Rev.	Date	Page	Description
2.06	Mar 21, 2024	P24	4.1 Absolute Maximum Ratings Updated the ratings for HVP0, HVP1, HVP2 of Input voltage
		P66	6.2 Typical Application Circuit Updated the figure
		P72	6.3.7 Thermistor Updated the figure and description (recommend adding a capacitor to ANx port)
		P73	6.3.8 Communication line Updated the description for CAN transceivers power supply
		P75	6.3.10 VCC, CREG2S, VDD and REGC capacitance Updated recommended capacitance rage of CREG2 and REGC
		P76	6.3.11 External CREG2 output option Added this part
		P77	6.3.11 Crystal oscillators port XT1 and XT2 for RTC Added this part

# General Precautions in the Handling of Microprocessing Unit and Microcontroller Unit Products

The following usage notes are applicable to all Microprocessing unit and Microcontroller unit products from Renesas. For detailed usage notes on the products covered by this document, refer to the relevant sections of the document as well as any technical updates that have been issued for the products.

## 1. Precaution against Electrostatic Discharge (ESD)

A strong electrical field, when exposed to a CMOS device, can cause destruction of the gate oxide and ultimately degrade the device operation. Steps must be taken to stop the generation of static electricity as much as possible, and quickly dissipate it when it occurs. Environmental control must be adequate. When it is dry, a humidifier should be used. This is recommended to avoid using insulators that can easily build up static electricity. Semiconductor devices must be stored and transported in an anti-static container, static shielding bag or conductive material. All test and measurement tools including work benches and floors must be grounded. The operator must also be grounded using a wrist strap. Semiconductor devices must not be touched with bare hands. Similar precautions must be taken for printed circuit boards with mounted semiconductor devices.

## 2. Processing at power-on

The state of the product is undefined at the time when power is supplied. The states of internal circuits in the LSI are indeterminate and the states of register settings and pins are undefined at the time when power is supplied. In a finished product where the reset signal is applied to the external reset pin, the states of pins are not guaranteed from the time when power is supplied until the reset process is completed. In a similar way, the states of pins in a product that is reset by an on-chip power-on reset function are not guaranteed from the time when power is supplied until the power reaches the level at which resetting is specified.

## 3. Input of signal during power-off state

Do not input signals or an I/O pull-up power supply while the device is powered off. The current injection that results from input of such a signal or I/O pull-up power supply may cause malfunction and the abnormal current that passes in the device at this time may cause degradation of internal elements. Follow the guideline for input signal during power-off state as described in your product documentation.

## 4. Handling of unused pins

Handle unused pins in accordance with the directions given under handling of unused pins in the manual. The input pins of CMOS products are generally in the high-impedance state. In operation with an unused pin in the open-circuit state, extra electromagnetic noise is induced in the vicinity of the LSI, an associated shoot-through current flows internally, and malfunctions occur due to the false recognition of the pin state as an input signal become possible.

## 5. Clock signals

After applying a reset, only release the reset line after the operating clock signal becomes stable. When switching the clock signal during program execution, wait until the target clock signal is stabilized. When the clock signal is generated with an external resonator or from an external oscillator during a reset, ensure that the reset line is only released after full stabilization of the clock signal. Additionally, when switching to a clock signal produced with an external resonator or by an external oscillator while program execution is in progress, wait until the target clock signal is stable.

## 6. Voltage application waveform at input pin

Waveform distortion due to input noise or a reflected wave may cause malfunction. If the input of the CMOS device stays in the area between  $V_{IL}$  (Max.) and  $V_{IH}$  (Min.) due to noise, for example, the device may malfunction. Take care to prevent chattering noise from entering the device when the input level is fixed, and also in the transition period when the input level passes through the area between  $V_{IL}$  (Max.) and  $V_{IH}$  (Min.).

## 7. Prohibition of access to reserved addresses

Access to reserved addresses is prohibited. The reserved addresses are provided for possible future expansion of functions. Do not access these addresses as the correct operation of the LSI is not guaranteed.

## 8. Differences between products

Before changing from one product to another, for example to a product with a different part number, confirm that the change will not lead to problems. The characteristics of a microprocessing unit or microcontroller unit products in the same group but having a different part number might differ in terms of internal memory capacity, layout pattern, and other factors, which can affect the ranges of electrical characteristics, such as characteristic values, operating margins, immunity to noise, and amount of radiated noise. When changing to a product with a different part number, implement a system-evaluation test for the given product.

## Notice

1. Descriptions of circuits, software and other related information in this document are provided only to illustrate the operation of semiconductor products and application examples. You are fully responsible for the incorporation or any other use of the circuits, software, and information in the design of your product or system. Renesas Electronics disclaims any and all liability for any losses and damages incurred by you or third parties arising from the use of these circuits, software, or information.
2. Renesas Electronics hereby expressly disclaims any warranties against and liability for infringement or any other claims involving patents, copyrights, or other intellectual property rights of third parties, by or arising from the use of Renesas Electronics products or technical information described in this document, including but not limited to, the product data, drawings, charts, programs, algorithms, and application examples.
3. No license, express, implied or otherwise, is granted hereby under any patents, copyrights or other intellectual property rights of Renesas Electronics or others.
4. You shall be responsible for determining what licenses are required from any third parties, and obtaining such licenses for the lawful import, export, manufacture, sales, utilization, distribution or other disposal of any products incorporating Renesas Electronics products, if required.
5. You shall not alter, modify, copy, or reverse engineer any Renesas Electronics product, whether in whole or in part. Renesas Electronics disclaims any and all liability for any losses or damages incurred by you or third parties arising from such alteration, modification, copying or reverse engineering.
6. Renesas Electronics products are classified according to the following two quality grades: "Standard" and "High Quality". The intended applications for each Renesas Electronics product depends on the product's quality grade, as indicated below.

"Standard": Computers; office equipment; communications equipment; test and measurement equipment; audio and visual equipment; home electronic appliances; machine tools; personal electronic equipment; industrial robots; etc.

"High Quality": Transportation equipment (automobiles, trains, ships, etc.); traffic control (traffic lights); large-scale communication equipment; key financial terminal systems; safety control equipment; etc.

Unless expressly designated as a high reliability product or a product for harsh environments in a Renesas Electronics data sheet or other Renesas Electronics document, Renesas Electronics products are not intended or authorized for use in products or systems that may pose a direct threat to human life or bodily injury (artificial life support devices or systems; surgical implantations; etc.), or may cause serious property damage (space system; undersea repeaters; nuclear power control systems; aircraft control systems; key plant systems; military equipment; etc.). Renesas Electronics disclaims any and all liability for any damages or losses incurred by you or any third parties arising from the use of any Renesas Electronics product that is inconsistent with any Renesas Electronics data sheet, user's manual or other Renesas Electronics document.

7. No semiconductor product is absolutely secure. Notwithstanding any security measures or features that may be implemented in Renesas Electronics hardware or software products, Renesas Electronics shall have absolutely no liability arising out of any vulnerability or security breach, including but not limited to any unauthorized access to or use of a Renesas Electronics product or a system that uses a Renesas Electronics product. RENESAS ELECTRONICS DOES NOT WARRANT OR GUARANTEE THAT RENESAS ELECTRONICS PRODUCTS, OR ANY SYSTEMS CREATED USING RENESAS ELECTRONICS PRODUCTS WILL BE INVULNERABLE OR FREE FROM CORRUPTION, ATTACK, VIRUSES, INTERFERENCE, HACKING, DATA LOSS OR THEFT, OR OTHER SECURITY INTRUSION ("Vulnerability Issues"). RENESAS ELECTRONICS DISCLAIMS ANY AND ALL RESPONSIBILITY OR LIABILITY ARISING FROM OR RELATED TO ANY VULNERABILITY ISSUES. FURTHERMORE, TO THE EXTENT PERMITTED BY APPLICABLE LAW, RENESAS ELECTRONICS DISCLAIMS ANY AND ALL WARRANTIES, EXPRESS OR IMPLIED, WITH RESPECT TO THIS DOCUMENT AND ANY RELATED OR ACCOMPANYING SOFTWARE OR HARDWARE, INCLUDING BUT NOT LIMITED TO THE IMPLIED WARRANTIES OF MERCHANTABILITY, OR FITNESS FOR A PARTICULAR PURPOSE.
8. When using Renesas Electronics products, refer to the latest product information (data sheets, user's manuals, application notes, "General Notes for Handling and Using Semiconductor Devices" in the reliability handbook, etc.), and ensure that usage conditions are within the ranges specified by Renesas Electronics with respect to maximum ratings, operating power supply voltage range, heat dissipation characteristics, installation, etc. Renesas Electronics disclaims any and all liability for any malfunctions, failure or accident arising out of the use of Renesas Electronics products outside of such specified ranges.
9. Although Renesas Electronics endeavors to improve the quality and reliability of Renesas Electronics products, semiconductor products have specific characteristics, such as the occurrence of failure at a certain rate and malfunctions under certain use conditions. Unless designated as a high reliability product or a product for harsh environments in a Renesas Electronics data sheet or other Renesas Electronics document, Renesas Electronics products are not subject to radiation resistance design. You are responsible for implementing safety measures to guard against the possibility of bodily injury, injury or damage caused by fire, and/or danger to the public in the event of a failure or malfunction of Renesas Electronics products, such as safety design for hardware and software, including but not limited to redundancy, fire control and malfunction prevention, appropriate treatment for aging degradation or any other appropriate measures. Because the evaluation of microcomputer software alone is very difficult and impractical, you are responsible for evaluating the safety of the final products or systems manufactured by you.
10. Please contact a Renesas Electronics sales office for details as to environmental matters such as the environmental compatibility of each Renesas Electronics product. You are responsible for carefully and sufficiently investigating applicable laws and regulations that regulate the inclusion or use of controlled substances, including without limitation, the EU RoHS Directive, and using Renesas Electronics products in compliance with all these applicable laws and regulations. Renesas Electronics disclaims any and all liability for damages or losses occurring as a result of your noncompliance with applicable laws and regulations.
11. Renesas Electronics products and technologies shall not be used for or incorporated into any products or systems whose manufacture, use, or sale is prohibited under any applicable domestic or foreign laws or regulations. You shall comply with any applicable export control laws and regulations promulgated and administered by the governments of any countries asserting jurisdiction over the parties or transactions.
12. It is the responsibility of the buyer or distributor of Renesas Electronics products, or any other party who distributes, disposes of, or otherwise sells or transfers the product to a third party, to notify such third party in advance of the contents and conditions set forth in this document.
13. This document shall not be reprinted, reproduced or duplicated in any form, in whole or in part, without prior written consent of Renesas Electronics.
14. Please contact a Renesas Electronics sales office if you have any questions regarding the information contained in this document or Renesas Electronics products.

(Note1) "Renesas Electronics" as used in this document means Renesas Electronics Corporation and also includes its directly or indirectly controlled subsidiaries.

(Note2) "Renesas Electronics product(s)" means any product developed or manufactured by or for Renesas Electronics.

(Rev.5.0-1 October 2020)

## Corporate Headquarters

TOYOSU FORESIA, 3-2-24 Toyosu,  
Koto-ku, Tokyo 135-0061, Japan  
[www.renesas.com](http://www.renesas.com)

## Trademarks

Renesas and the Renesas logo are trademarks of Renesas Electronics Corporation. All trademarks and registered trademarks are the property of their respective owners.

## Contact information







For further information on a product, technology, the most up-to-date version of a document, or your nearest sales office, please visit:  
[www.renesas.com/contact/](http://www.renesas.com/contact/)

## Looking for pricing, stock, or lifecycle information?

Click below to explore more details on WIN SOURCE:

-  [View RAJ240100A20GFP#HC2 on WIN SOURCE](#)
-  [Renesas Electronics America Information](#)

## Optimize Your Supply Chain with WIN SOURCE Solutions

-  Global Sourcing Solution
-  Obsolete Management
-  Cost Control Management
-  Shortage Management
-  Alternative Solution
-  Excess Inventory Management