



**THE DATASHEET OF
MC33984CHFKR2**



Dual intelligent high-current self-protected silicon high-side switch (4.0 mOhm)

The 33984 is a dual self-protected 4.0 mOhm silicon switch used to replace electromechanical relays, fuses, and discrete devices in power management applications. The 33984 is designed for harsh environments, and it includes self-recovery features. The device is suitable for loads with high inrush current, as well as motors and all types of resistive and inductive loads.

Programming, control, and diagnostics are implemented via the serial peripheral interface (SPI). A dedicated parallel input is available for alternate and pulse-width modulation (PWM) control of each output. SPI-programmable fault trip thresholds allow the device to be adjusted for optimal performance in the application.

The 33984 is packaged in a power-enhanced 12 mm x 12 mm nonleaded PQFN package with exposed tabs.

Features

- Dual 4.0 mΩ max. high-side switch with parallel input or SPI control
- 6.0 V to 27 V operating voltage with standby currents < 5.0 μA
- Output current monitoring with two SPI-selectable current ratios
- SPI control of overcurrent limit, overcurrent fault blanking time, output OFF open load detection, output ON/OFF control, watchdog timeout, slew-rates, and fault status reporting
- SPI status reporting of overcurrent, open and shorted loads, overtemperature, undervoltage and overvoltage shutdown, fail-safe pin status, and program status
- Enhanced -16 V reverse polarity V_{PWR} protection

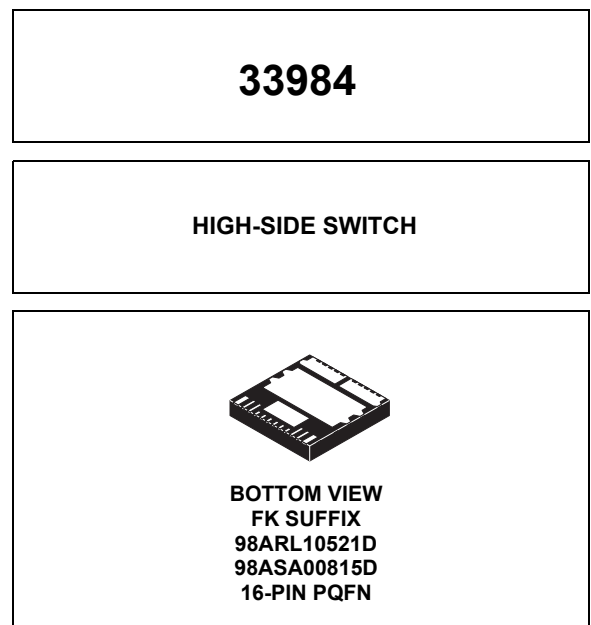

Applications

- DC motor or solenoid
- Resistive or inductive loads
- Low-voltage lighting

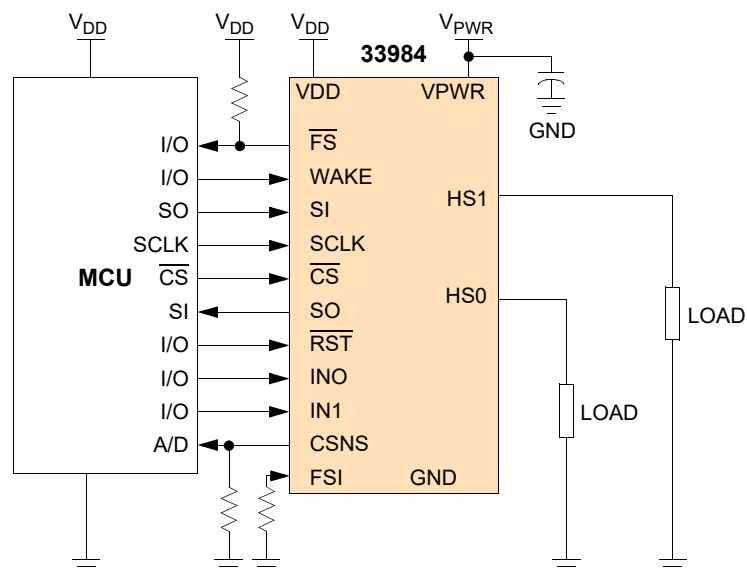

Figure 1. 33984 simplified application diagram

Orderable parts

Table 1. Orderable part variations ⁽¹⁾

| Part Number | Temperature (T _A) | Package | Output Clamp Energy | Reference Location | OD3 bit for X111 address | Reference Location |
|-------------|-------------------------------|---------|---------------------|-------------------------|--------------------------|--------------------------|
| MC33984CHFK | -40 °C to 125 °C | 16 PQFN | 0.5J | Table 3 | 1 | Table 16 |
| MC33984EHFK | -40 °C to 125 °C | 16 PQFN | 0.3J | Table 3 | 1 | Table 16 |

Notes

1. To order parts in Tape & Reel, add the R2 suffix to the part number.

Internal block diagram

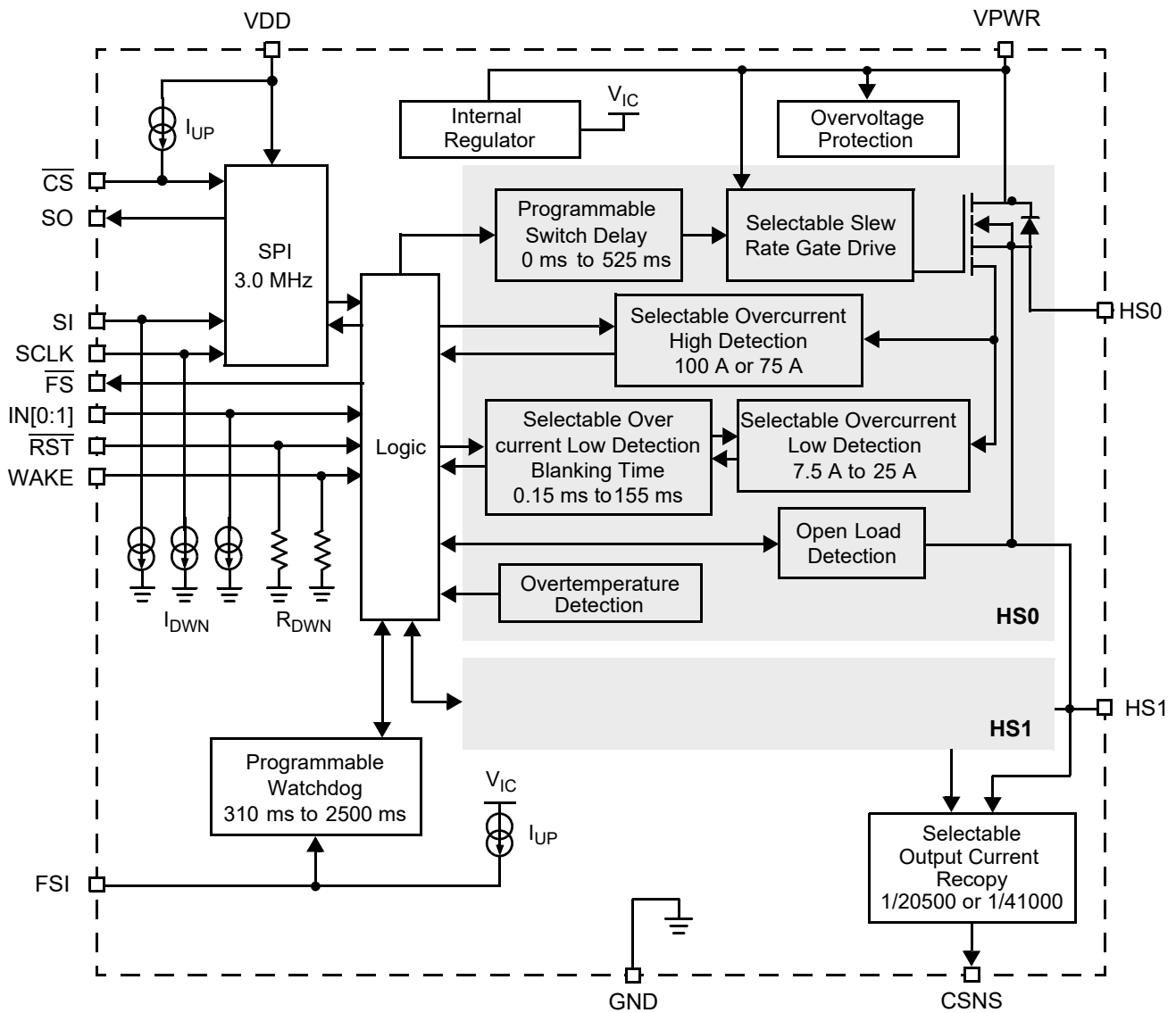

Figure 2. 33984 simplified internal block diagram

Pin connections

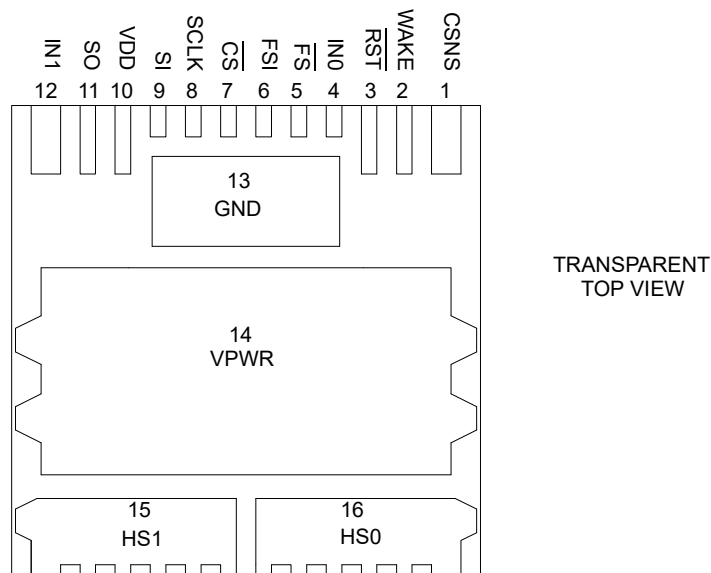

Figure 3. 33984 pin connections (transparent top view)

Functional descriptions of many of these pins can be found in the Functional Pin Description section beginning on [page 19](#).

Table 2. Pin definitions

| Pin | Pin Name | Pin Function | Formal Name | Definition |
|-----|-------------------------|--------------|-------------------------------|----------------------------------------------------------------------------------------------------------------------------------------------------------|
| 1 | CSNS | Output | Output Current Monitoring | This pin is used to output a current proportional to the designated HS0-1 output. |
| 2 | WAKE | Input | Wake | This pin is used to input a logic [1] signal so as to enable the watchdog timer function. |
| 3 | $\overline{\text{RST}}$ | Input | Reset (Active Low) | This input pin is used to initialize the device configuration and fault registers, as well as place the device in a low current Sleep mode. |
| 4 | IN0 | Input | Direct Input 0 | This input pin is used to directly control the output HS0. |
| 5 | $\overline{\text{FS}}$ | Output | Fault Status (Active Low) | This is an open drain configured output requiring an external pull-up resistor to VDD for fault reporting. |
| 6 | FSI | Input | Fail-safe Input | The value of the resistance connected between this pin and ground determines the state of the outputs after a watchdog timeout occurs. |
| 7 | $\overline{\text{CS}}$ | Input | Chip Select (Active Low) | This input pin is connected to a chip select output of a master microcontroller (MCU). |
| 8 | SCLK | Input | Serial Clock | This input pin is connected to the MCU providing the required bit shift clock for SPI communication. |
| 9 | SI | Input | Serial Input | This is a command data input pin connected to the SPI serial data output of the MCU or to the SO pin of the previous device of a daisy chain of devices. |
| 10 | VDD | Input | Digital Drain Voltage (Power) | This is an external voltage input pin used to supply power to the SPI circuit. |
| 11 | SO | Output | Serial Output | This output pin is connected to the SPI serial data input pin of the MCU or to the SI pin of the next device of a daisy chain of devices. |
| 12 | IN1 | Input | Direct Input 1 | This input pin is used to directly control the output HS1. |
| 13 | GND | Ground | Ground | This pin is the ground for the logic and analog circuitry of the device. |

Table 2. Pin definitions (continued)

| Pin | Pin Name | Pin Function | Formal Name | Definition |
|-----|----------|--------------|-----------------------|-------------------------------------------------------------------------------------------------------------|
| 14 | VPWR | Input | Positive Power Supply | This pin connects to the positive power supply and is the source input of operational power for the device. |
| 15 | HS1 | Output | High-side Output 1 | Protected 4.0 m Ω high-side power output to the load. |
| 16 | HS0 | Output | High-side Output 0 | Protected 4.0 m Ω high-side power output to the load. |

Electrical characteristics

Maximum ratings

Table 3. Maximum ratings

All voltages are with respect to ground unless otherwise noted.

| Symbol | Rating | Value | Unit | Notes |
|----------------------------------------------------------------------|-------------------------------------------------------------------------------------------------------------------------------------|--------------------------------------|------|-------|
| ELECTRICAL RATINGS | | | | |
| V_{PWR} | Operating Voltage Range Steady-state | -16 to 41 | V | |
| V_{DD} | VDD Supply Voltage | -0.3 to 5.5 | V | |
| $V_{IN[0:1]}, \overline{RST}, FSI,$ $CSNS, SI, SCLK,$ CS, FS | Input/Output Voltage | -0.3 to 7.0 | V | (1) |
| V_{SO} | SO Output Voltage | -0.3 to $V_{DD}+0.3$ | V | (1) |
| $I_{CL(WAKE)}$ | WAKE Input Clamp Current | 2.5 | mA | |
| $I_{CL(CSNS)}$ | CSNS Input Clamp Current | 10 | mA | |
| V_{HS} | Output Voltage Positive Negative | 41 -15 | V | |
| $I_{HS[0:1]}$ | Output Current | 30 | A | (2) |
| $E_{CL[0:1]}$ | Output Clamp Energy MC33984CHFK MC33984EHFK | 0.5 0.3 | J | (3) |
| V_{ESD1} V_{ESD3} | ESD Voltage Human Body Model (HBM) Charge Device Model (CDM) Corner Pins (1, 12, 15, 16) All Other Pins (2, 11, 13, 14) | ± 2000 ± 750 ± 500 | V | (4) |

Notes

- Exceeding this voltage limit may cause permanent damage to the device.
- Continuous high-side output current rating so long as maximum junction temperature is not exceeded. Calculation of maximum output current using package thermal resistance is required.
- Active clamp energy using single-pulse method ($L = 16$ mH, $R_L = 0$, $V_{PWR} = 12$ V, $T_J = 150$ °C).
- ESD1 testing is performed in accordance with the Human Body Model (HBM) ($C_{ZAP} = 100$ pF, $R_{ZAP} = 1500$ Ω); ESD3 testing is performed in accordance with the Charge Device Model (CDM), Robotic ($C_{ZAP} = 4.0$ pF).

Table 3. Maximum ratings (continued)

All voltages are with respect to ground unless otherwise noted.

| Symbol | Rating | Value | Unit | Notes |
|------------------------------------|---------------------------------------------------------------|--------------------------|------|----------|
| THERMAL RATINGS | | | | |
| T_A T_J | Operating Temperature Ambient Junction | -40 to 125 -40 to 150 | °C | |
| T_{STG} | Storage Temperature | -55 to 150 | °C | |
| $R_{\theta JC}$ $R_{\theta JA}$ | Thermal Resistance Junction-to-Case Junction-to-Ambient | <1.0 30 | °C/W | (5) |
| T_{PPRT} | Peak Package Reflow Temperature During Reflow | Note 7 | °C | (6), (7) |

Notes

5. Device mounted on a 2s2p test board according to JEDEC JESD51-2.
6. Pin soldering temperature limit is for 40 seconds maximum duration. Not designed for immersion soldering. Exceeding these limits may cause malfunction or permanent damage to the device.
7. NXP's Package Reflow capability meets Pb-free requirements for JEDEC standard J-STD-020. For Peak Package Reflow Temperature and Moisture Sensitivity Levels (MSL), Go to www.nxp.com, search by part number [e.g. remove prefixes/suffixes and enter the core ID to view all orderable parts. (i.e. MC33xxxD enter 33xxx), and review parametrics.

Static electrical characteristics**Table 4. Static electrical characteristics**

Characteristics noted under conditions $4.5\text{ V} \leq V_{DD} \leq 5.5\text{ V}$, $6.0\text{ V} \leq V_{PWR} \leq 27\text{ V}$, $-40\text{ }^\circ\text{C} \leq T_A \leq 125\text{ }^\circ\text{C}$, unless otherwise noted. Typical values noted reflect the approximate parameter mean at $T_A = 25\text{ }^\circ\text{C}$ under nominal conditions, unless otherwise noted.

| Symbol | Characteristic | Min | Typ | Max | Unit | Notes |
|--------------------|---------------------------------------------------------------------------------------------------------------------------------------------------------------------------------------------|--------|--------|------------|---------------|-------|
| POWER INPUT | | | | | | |
| V_{PWR} | Battery Supply Voltage Range Full Operational | 6.0 | – | 27 | V | |
| $I_{PWR(ON)}$ | VPWR Operating Supply Current Output ON, I_{HS0} and $I_{HS1} = 0\text{ A}$ | – | – | 20 | mA | |
| $I_{PWR(SBY)}$ | VPWR Supply Current Output OFF, Open Load Detection Disabled, $WAKE > 0.7 \times V_{DD}$, $\overline{RST} = V_{LOGIC\ HIGH}$ | – | – | 5.0 | mA | |
| $I_{PWR(SLEEP)}$ | Sleep State Supply Current ($V_{PWR} < 14\text{ V}$, $\overline{RST} < 0.5\text{ V}$, $WAKE < 0.5\text{ V}$) $T_J = 25\text{ }^\circ\text{C}$ $T_J = 85\text{ }^\circ\text{C}$ | – – | – – | 10 50 | μA | |
| $V_{DD(ON)}$ | VDD Supply Voltage | 4.5 | 5.0 | 5.5 | V | |
| $I_{DD(ON)}$ | VDD Supply Current No SPI Communication 3.0 MHz SPI Communication | – – | – – | 1.0 5.0 | mA | |
| $I_{DD(SLEEP)}$ | VDD Sleep State Current | – | – | 5.0 | μA | |
| $V_{PWR(OV)}$ | Overvoltage Shutdown Threshold | 28 | 32 | 36 | V | |
| $V_{PWR(OVHYS)}$ | Overvoltage Shutdown Hysteresis | 0.2 | 0.8 | 1.5 | V | |
| $V_{PWR(UV)}$ | Undervoltage Output Shutdown Threshold | 5.0 | 5.5 | 6.0 | V | (8) |
| $V_{PWR(UVHYS)}$ | Undervoltage Hysteresis | – | 0.25 | – | V | (9) |
| $V_{PWR(UVPOR)}$ | Undervoltage Power-ON Reset | – | – | 5.0 | V | |

POWER OUTPUT

| | | | | | | |
|--------------|--------------------------------------------------------------------------------------------------------------------------------------------------------------------------------------------|-------------|-------------|--------------------|------------------|------|
| $R_{DS(on)}$ | Output Drain-to-Source ON Resistance ($I_{HS[0:1]} = 15\text{ A}$, $T_J = 25\text{ }^\circ\text{C}$) $V_{PWR} = 6.0\text{ V}$ $V_{PWR} = 10\text{ V}$ $V_{PWR} = 13\text{ V}$ | – – – | – – – | 6.0 4.0 4.0 | $\text{m}\Omega$ | |
| $R_{DS(on)}$ | Output Drain-to-Source ON Resistance ($I_{HS[0:1]} = 15\text{ A}$, $T_J = 150\text{ }^\circ\text{C}$) $V_{PWR} = 6.0\text{ V}$ $V_{PWR} = 10\text{ V}$ $V_{PWR} = 13\text{ V}$ | – – – | – – – | 10.2 6.8 6.8 | $\text{m}\Omega$ | |
| $R_{DS(on)}$ | Output Source-to-Drain ON Resistance $I_{HS[0:1]} = 15\text{ A}$, $T_J = 25\text{ }^\circ\text{C}$ $V_{PWR} = -12\text{ V}$ | – | – | 8.0 | $\text{m}\Omega$ | (10) |

Notes

8. This applies to all internal device logic supplied by V_{PWR} and assumes the external V_{DD} supply is within specification.
9. This applies when the undervoltage fault is not latched ($IN[0:1] = 0$).
10. Source-Drain ON Resistance (Reverse Drain-to-Source ON Resistance) with negative polarity V_{PWR} .

Table 4. Static electrical characteristics (continued)

Characteristics noted under conditions $4.5\text{ V} \leq V_{DD} \leq 5.5\text{ V}$, $6.0\text{ V} \leq V_{PWR} \leq 27\text{ V}$, $-40\text{ }^{\circ}\text{C} \leq T_A \leq 125\text{ }^{\circ}\text{C}$, unless otherwise noted. Typical values noted reflect the approximate parameter mean at $T_A = 25\text{ }^{\circ}\text{C}$ under nominal conditions, unless otherwise noted.

| Symbol | Characteristic | Min | Typ | Max | Unit | Notes |
|------------------|-------------------------------------------------------------------------------------------------|-----|-----|-----|--------------------|-------|
| $V_{OLD(THRES)}$ | Output Fault Detection Threshold Output Programmed OFF | 2.0 | 3.0 | 4.0 | V | |
| V_{CL} | Output Negative Clamp Voltage $0.5\text{ A} \leq I_{HS[0:1]} \leq 2.0\text{ A}$, Output OFF | -20 | – | -15 | V | |
| T_{SD} | Overtemperature Shutdown | 160 | 175 | 190 | $^{\circ}\text{C}$ | (12) |
| $T_{SD(HYS)}$ | Overtemperature Shutdown Hysteresis | 5.0 | – | 20 | $^{\circ}\text{C}$ | (12) |

Notes

11. Output OFF Open Load Detection Current is the current required to flow through the load for the purpose of detecting the existence of an open load condition when the specific output is commanded OFF.
12. Guaranteed by process monitoring. Not production tested.

Table 4. Static electrical characteristics (continued)

Characteristics noted under conditions $4.5\text{ V} \leq V_{DD} \leq 5.5\text{ V}$, $6.0\text{ V} \leq V_{PWR} \leq 27\text{ V}$, $-40\text{ }^\circ\text{C} \leq T_A \leq 125\text{ }^\circ\text{C}$, unless otherwise noted. Typical values noted reflect the approximate parameter mean at $T_A = 25\text{ }^\circ\text{C}$ under nominal conditions, unless otherwise noted.

| Symbol | Characteristic | Min | Typ | Max | Unit | Notes |
|---------------------------------------------------------------------------------------------------|---------------------------------------------------------------------------------------------------------------------------------------------------------------------------|----------------------|----------------------------|-----------------------|------------------|-------|
| Control Interface | | | | | | |
| V_{IH} | Input Logic High-voltage | $0.7 \times V_{DD}$ | – | – | V | (13) |
| V_{IL} | Input Logic Low-voltage | – | – | $0.2 \times V_{DD}$ | V | (13) |
| $V_{IN[0:1](HYS)}$ | Input Logic Voltage Hysteresis | 100 | 600 | 1200 | mV | (14) |
| I_{DWN} | Input Logic Pull-down Current (SCLK, IN, SI) | 5.0 | – | 20 | μA | |
| $V_{\overline{RST}}$ | \overline{RST} Input Voltage Range | 4.5 | 5.0 | 5.5 | V | |
| C_{SO} | SO, \overline{FS} Tri-state Capacitance | – | – | 20 | pF | (15) |
| R_{DWN} | Input Logic Pull-down Resistor (\overline{RST}) and WAKE | 100 | 200 | 400 | $\text{k}\Omega$ | |
| C_{IN} | Input Capacitance | – | 4.0 | 12 | pF | (15) |
| $V_{CL(WAKE)}$ | WAKE Input Clamp Voltage $I_{CL(WAKE)} < 2.5\text{ mA}$ | 7.0 | – | 14 | V | (16) |
| $V_{F(WAKE)}$ | WAKE Input Forward Voltage $I_{CL(WAKE)} = -2.5\text{ mA}$ | -2.0 | – | -0.3 | V | |
| V_{SOH} | SO High-state Output Voltage $I_{OH} = 1.0\text{ mA}$ | $0.8 \times V_{DD}$ | – | – | V | |
| V_{SOL} | \overline{FS} , SO Low-state Output Voltage $I_{OL} = -1.6\text{ mA}$ | – | 0.2 | 0.4 | V | |
| $I_{SO(LEAK)}$ | SO Tri-state Leakage Current $\overline{CS} > 0.7 V_{DD}$ | -5.0 | 0.0 | 5.0 | μA | |
| I_{UP} | Input Logic Pull-up Current \overline{CS} , $V_{IN[0:1]} > 0.7 \times V_{DD}$ | 5.0 | – | 20 | μA | (17) |
| RFS RFS _{DIS} RFS _{OFFOFF} RFS _{ONOFF} RFS _{ONON} | FSI Input Pin External Pull-down Resistance FSI Disabled, HS[0:1] Indeterminate FSI Enabled, HS[0:1] OFF FSI Enabled, HS0 ON, HS1 OFF FSI Enabled, HS[0:1] ON | – 6.0 15 40 | 0 6.5 17 Infinite | 1.0 7.0 19 – | $\text{k}\Omega$ | |

Notes

- Upper and lower logic threshold voltage range applies to SI, \overline{CS} , SCLK, \overline{RST} , IN[0:1], and WAKE input signals. The WAKE and \overline{RST} signals may be supplied by a derived voltage reference to V_{PWR} .
- No hysteresis on FSI and WAKE pins. Parameter is guaranteed by processing monitoring but is not production tested.
- Input capacitance of SI, \overline{CS} , SCLK, \overline{RST} , and WAKE. This parameter is guaranteed by process monitoring but is not production tested.
- The current must be limited by a series resistance when using voltages $> 7.0\text{ V}$.
- Pull-up current is with \overline{CS} OPEN. \overline{CS} has an active internal pull-up to V_{DD} .

Dynamic electrical characteristics**Table 5. Dynamic electrical characteristics**

Characteristics noted under conditions $4.5\text{ V} \leq V_{DD} \leq 5.5\text{ V}$, $6.0\text{ V} \leq V_{PWR} \leq 27\text{ V}$, $-40\text{ }^\circ\text{C} \leq T_A \leq 125\text{ }^\circ\text{C}$, unless otherwise noted. Typical values noted reflect the approximate parameter mean at $T_A = 25\text{ }^\circ\text{C}$ under nominal conditions, unless otherwise noted.

| Symbol | Characteristic | Min | Typ | Max | Unit | Notes |
|----------------------------------------------------------------------------------|----------------------------------------------------------------------------------------------------------------|---------------------------|--------------------------|--------------------------|------|-------|
| POWER OUTPUT TIMING | | | | | | |
| SR _{RA_SLOW} | Output Rising Slow Slew Rate A (DICR D3 = 0) 9.0 V < V _{PWR} < 16 V MC33984CHFK MC33984EHFK | 0.15 0.15 | 0.5 0.5 | 1.0 1.3 | V/μs | (18) |
| SR _{RB_SLOW} | Output Rising Slow Slew Rate B (DICR D3 = 0) 9.0 V < V _{PWR} < 16 V | 0.06 | 0.2 | 0.6 | V/μs | (19) |
| SR _{RA_FAST} | Output Rising Fast Slew Rate A (DICR D3 = 1) 9.0 V < V _{PWR} < 16 V | 0.3 | 0.8 | 3.2 | V/μs | (18) |
| SR _{RB_FAST} | Output Rising Fast Slew Rate B (DICR D3 = 1) 9.0 V < V _{PWR} < 16 V | 0.06 | 0.2 | 2.4 | V/μs | (19) |
| SR _{FA_SLOW} | Output Falling Slow Slew Rate A (DICR D3 = 0) 9.0 V < V _{PWR} < 16 V MC33984CHFK MC33984EHFK | 0.15 0.15 | 0.5 0.5 | 1.0 1.3 | V/μs | (18) |
| SR _{FB_SLOW} | Output Falling Slow Slew Rate B (DICR D3 = 0) 9.0 V < V _{PWR} < 16 V | 0.06 | 0.2 | 0.6 | V/μs | (19) |
| SR _{FA_FAST} | Output Falling Fast Slew Rate A (DICR D3 = 1) 9.0 V < V _{PWR} < 16 V MC33984CHFK MC33984EHFK | 0.6 0.6 | 1.6 1.6 | 3.2 5.8 | V/μs | (18) |
| SR _{FB_FAST} | Output Falling Fast Slew Rate B (DICR D3 = 1) 9.0 V < V _{PWR} < 16 V | 0.2 | 0.7 | 2.4 | V/μs | (19) |
| t _{DLY(ON)} | Output Turn-ON Delay Time in Fast/Slow Slew Rate DICR = 0, DICR = 1 MC33984CHFK MC33984EHFK | 1.0 0.1 | 18 18 | 100 100 | μs | (20) |
| t _{DLY_SLOW(OFF)} | Output Turn-OFF Delay Time in Slow Slew Rate Mode DICR = 0 | 10 | 115 | 250 | μs | (21) |
| t _{DLY_FAST(OFF)} | Output Turn-OFF Delay Time in Fast Slew Rate Mode DICR = 1 MC33984CHFK MC33984EHFK | 5.0 0.1 | 30 30 | 100 100 | μs | (21) |
| f _{PWM} | Direct Input Switching Frequency (DICR D3 = 0) | – | 300 | – | Hz | |
| t _{OCL0} t _{OCL1} t _{OCL2} t _{OCL3} | Overcurrent Detection Blanking Time (OCLT[1:0]) MC33984CHFK 00 01 10 11 | 108 7.0 0.8 0.08 | 155 10 1.2 0.15 | 202 13 1.6 0.25 | ms | |
| t _{OCL0} t _{OCL1} t _{OCL2} t _{OCL3} | MC33984EHFK 00 01 10 11 | 108 7.0 0.8 0.08 | 155 10 1.2 0.15 | 365 13 1.6 0.36 | | |

Table 5. Dynamic electrical characteristics (continued)

Characteristics noted under conditions $4.5\text{ V} \leq V_{DD} \leq 5.5\text{ V}$, $6.0\text{ V} \leq V_{PWR} \leq 27\text{ V}$, $-40\text{ }^{\circ}\text{C} \leq T_A \leq 125\text{ }^{\circ}\text{C}$, unless otherwise noted. Typical values noted reflect the approximate parameter mean at $T_A = 25\text{ }^{\circ}\text{C}$ under nominal conditions, unless otherwise noted.

| Symbol | Characteristic | Min | Typ | Max | Unit | Notes |
|----------------|-------------------------------------------|-----|-----|-----|---------------|-------|
| t_{OCH} | Overcurrent High Detection Blanking Time | 1.0 | 10 | 20 | μs | |
| t_{CNS_VAL} | $\overline{\text{CS}}$ to CSNS Valid Time | – | – | 10 | μs | (22) |

Notes

18. Rise and Fall Slew Rates A measured across a $5.0\ \Omega$ resistive load at high-side output = 0.5 V to $V_{PWR}-3.5\text{ V}$. These parameters are guaranteed by process monitoring.
19. Rise and Fall Slew Rates B measured across a $5.0\ \Omega$ resistive load at high-side output = $V_{PWR}-3.5\text{ V}$ to $V_{PWR}-0.5\text{ V}$. These parameters are guaranteed by process monitoring.
20. Turn-ON delay time measured from rising edge of $\text{IN}[0:1]$ signal would turn the output ON to $V_{\text{HS}[0:1]} = 0.5\text{ V}$ with $R_L = 5.0\ \Omega$ resistive load.
21. Turn-OFF delay time measured from falling edge would turn the output OFF to $V_{\text{HS}[0:1]} = V_{PWR}-0.5\text{ V}$ with $R_L = 5.0\ \Omega$ resistive load.
22. Time necessary for the CSNS to be within $\pm 5.0\%$ of the targeted value.

Table 5. Dynamic electrical characteristics (continued)

Characteristics noted under conditions $4.5\text{ V} \leq V_{DD} \leq 5.5\text{ V}$, $6.0\text{ V} \leq V_{PWR} \leq 27\text{ V}$, $-40\text{ }^\circ\text{C} \leq T_A \leq 125\text{ }^\circ\text{C}$, unless otherwise noted. Typical values noted reflect the approximate parameter mean at $T_A = 25\text{ }^\circ\text{C}$ under nominal conditions, unless otherwise noted.

| Symbol | Characteristic | Min | Typ | Max | Unit | Notes |
|----------------------------------------|------------------------------------------------------------------------------------------|------|------|------|---------------|-------|
| POWER OUTPUT TIMING (CONTINUED) | | | | | | |
| t_{OSD0} | HS1 Switching Delay Time (OSD[2:0]) 000 | – | 0 | – | | |
| t_{OSD1} | 001 | 55 | 75 | 95 | | |
| t_{OSD2} | 010 | 110 | 150 | 190 | | |
| t_{OSD3} | 011 | 165 | 225 | 285 | ms | |
| t_{OSD4} | 100 | 220 | 300 | 380 | | |
| t_{OSD5} | 101 | 275 | 375 | 475 | | |
| t_{OSD6} | 110 | 330 | 450 | 570 | | |
| t_{OSD7} | 111 | 385 | 525 | 665 | | |
| t_{OSD0} | HS0 Switching Delay Time (OSD[2:0]) 000 | – | 0 | – | | |
| t_{OSD1} | 001 | – | 0 | – | | |
| t_{OSD2} | 010 | 110 | 150 | 190 | | |
| t_{OSD3} | 011 | 110 | 150 | 190 | ms | |
| t_{OSD4} | 100 | 220 | 300 | 380 | | |
| t_{OSD5} | 101 | 220 | 300 | 380 | | |
| t_{OSD6} | 110 | 330 | 450 | 570 | | |
| t_{OSD7} | 111 | 330 | 450 | 570 | | |
| t_{WDTO0} | Watchdog Timeout (WD[1:0]) MC33984CHFK 00 | 434 | 620 | 806 | | |
| t_{WDTO1} | 01 | 207 | 310 | 403 | | |
| t_{WDTO2} | 10 | 1750 | 2500 | 3250 | | |
| t_{WDTO3} | 11 | 875 | 1250 | 1625 | ms | (23) |
| t_{WDTO0} | MC33984EHFK 00 | 434 | 620 | 1344 | | |
| t_{WDTO1} | 01 | 207 | 310 | 672 | | |
| t_{WDTO2} | 10 | 1750 | 2500 | 5377 | | |
| t_{WDTO3} | 11 | 875 | 1250 | 2688 | | |
| f_{SPI} | Recommended Frequency of SPI Operation | – | – | 3.0 | MHz | |
| t_{WRST} | Required Low State Duration for \overline{RST} | – | 50 | 350 | ns | (24) |
| t_{CS} | Rising Edge of \overline{CS} to Falling Edge of \overline{CS} (Required Setup Time) | – | – | 300 | ns | (25) |
| t_{ENBL} | Rising Edge of \overline{RST} to Falling Edge of \overline{CS} (Required Setup Time) | – | – | 5.0 | μs | (25) |
| t_{LEAD} | Falling Edge of \overline{CS} to Rising Edge of SCLK (Required Setup Time) | – | 50 | 167 | ns | (25) |
| t_{WSCLKh} | Required High State Duration of SCLK (Required Setup Time) | – | – | 167 | ns | (25) |
| t_{WSCLKl} | Required Low State Duration of SCLK (Required Setup Time) | – | – | 167 | ns | (25) |
| t_{LAG} | Falling Edge of SCLK to Rising Edge of \overline{CS} (Required Setup Time) | – | 50 | 167 | ns | (25) |
| $t_{SI(SU)}$ | SI to Falling Edge of SCLK (Required Setup Time) | – | 25 | 83 | ns | (26) |
| $t_{SI(HOLD)}$ | Falling Edge of SCLK to SI (Required Setup Time) | – | 25 | 83 | ns | (27) |
| t_{RSO} | SO Rise Time $C_L = 200\text{ pF}$ | – | 25 | 50 | ns | |
| t_{FSO} | SO Fall Time $C_L = 200\text{ pF}$ | – | 25 | 50 | ns | |

Table 5. Dynamic electrical characteristics (continued)

Characteristics noted under conditions $4.5\text{ V} \leq V_{DD} \leq 5.5\text{ V}$, $6.0\text{ V} \leq V_{PWR} \leq 27\text{ V}$, $-40\text{ }^\circ\text{C} \leq T_A \leq 125\text{ }^\circ\text{C}$, unless otherwise noted. Typical values noted reflect the approximate parameter mean at $T_A = 25\text{ }^\circ\text{C}$ under nominal conditions, unless otherwise noted.

| Symbol | Characteristic | Min | Typ | Max | Unit | Notes |
|--------|----------------|-----|-----|-----|------|-------|
|--------|----------------|-----|-----|-----|------|-------|

Notes

23. Watchdog timeout delay measured from the rising edge of WAKE to $\overline{\text{RST}}$ from a sleep-state condition to output turn-ON with the output driven OFF and FSI floating. The values shown are for WDR setting of [00]. The accuracy of t_{WDTO} is consistent for all configured watchdog timeouts.
24. $\overline{\text{RST}}$ low duration measured with outputs enabled and going to OFF or disabled condition.
25. Maximum setup time required for the 33984 is the minimum guaranteed time needed from the microcontroller.
26. Rise and Fall time of incoming SI, $\overline{\text{CS}}$, and SCLK signals suggested for design consideration to prevent the occurrence of double pulsing.

Table 5. Dynamic electrical characteristics (continued)

Characteristics noted under conditions $4.5\text{ V} \leq V_{DD} \leq 5.5\text{ V}$, $6.0\text{ V} \leq V_{PWR} \leq 27\text{ V}$, $-40\text{ }^\circ\text{C} \leq T_A \leq 125\text{ }^\circ\text{C}$, unless otherwise noted. Typical values noted reflect the approximate parameter mean at $T_A = 25\text{ }^\circ\text{C}$ under nominal conditions, unless otherwise noted.

| Symbol | Characteristic | Min | Typ | Max | Unit | Notes |
|--------------------------------------|------------------------------------------------------------------------------------------------------------------------------|-----|-----|-----|------|-------|
| SPI INTERFACE CHARACTERISTICS | | | | | | |
| t_{RSI} | SI, \overline{CS} , SCLK, Incoming Signal Rise Time | – | – | 50 | ns | (27) |
| t_{RSI} | SI, \overline{CS} , SCLK, Incoming Signal Fall Time | – | – | 50 | ns | (27) |
| $t_{SO(EN)}$ | Time from Falling Edge of \overline{CS} to SO Low-impedance | – | – | 145 | ns | (28) |
| $t_{SO(DIS)}$ | Time from Rising Edge of \overline{CS} to SO High-impedance | – | 65 | 145 | ns | (29) |
| t_{VALID} | Time from Rising Edge of SCLK to SO Data Valid $0.2 \times V_{DD} \leq SO \leq 0.8 \times V_{DD}$, $C_L = 200\text{ pF}$ | – | 65 | 105 | ns | (30) |

- Notes
27. Rise and Fall time of incoming SI, \overline{CS} , and SCLK signals suggested for design consideration to prevent the occurrence of double pulsing.
 28. Time required for output status data to be available for use at SO. 1.0 k Ω on pull-up on \overline{CS} .
 29. Time required for output status data to be terminated at SO. 1.0 k Ω on pull-up on \overline{CS} .
 30. Time required to obtain valid data out from SO following the rise of SCLK.

Timing diagrams

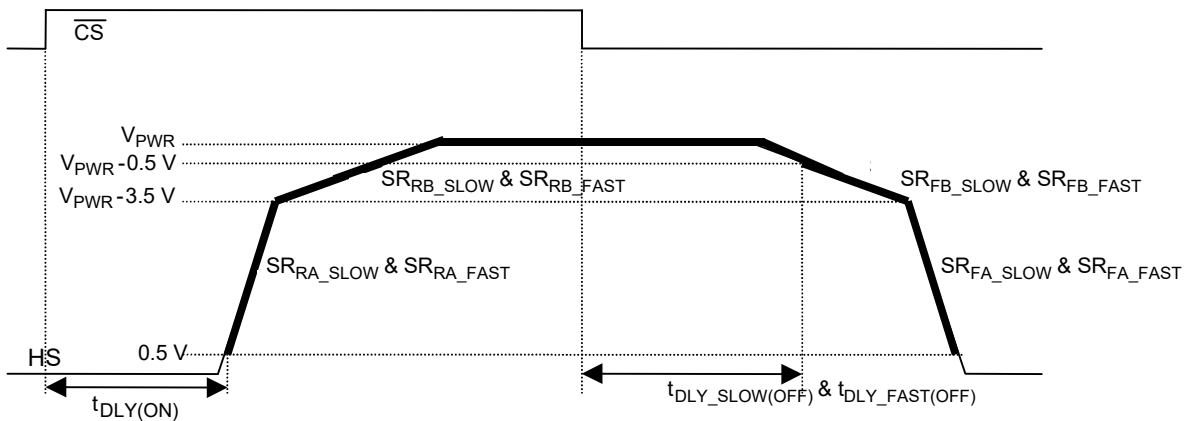

Figure 4. Output slew rate and time delays

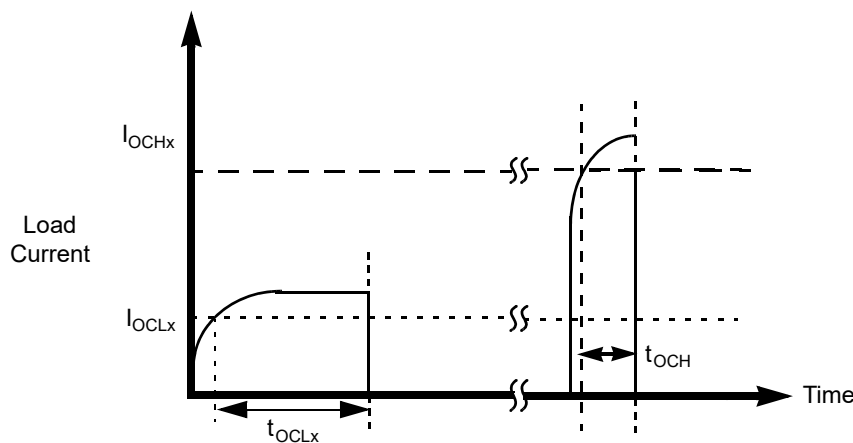

Figure 5. Overcurrent shutdown

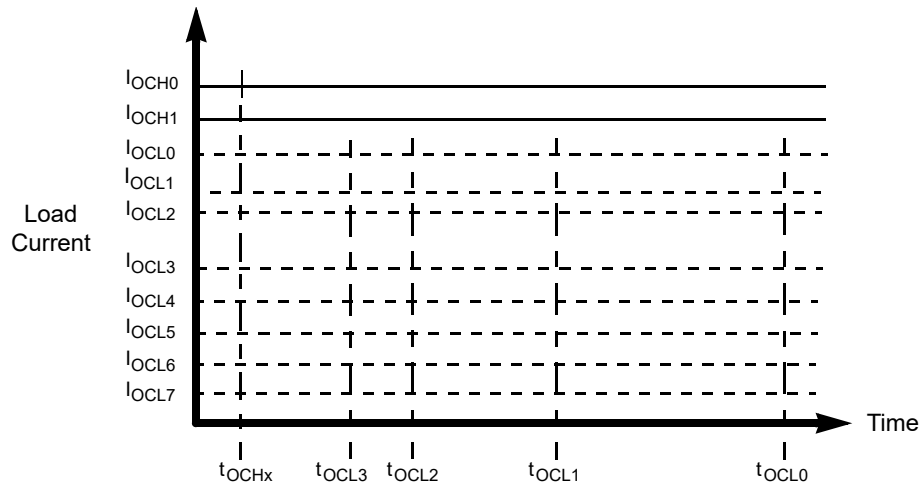

Figure 6. Overcurrent low and high detection

Figure 6 illustrates the overcurrent detection level (loclx, lochx) the device can reach for each overcurrent detection blanking time (tochx, toclx):

- During tochx, the device can reach up to loch0 overcurrent level.
- During tocl3 or tocl2 or tocl1 or tocl0, the device can be programmed to detect up to locl0.

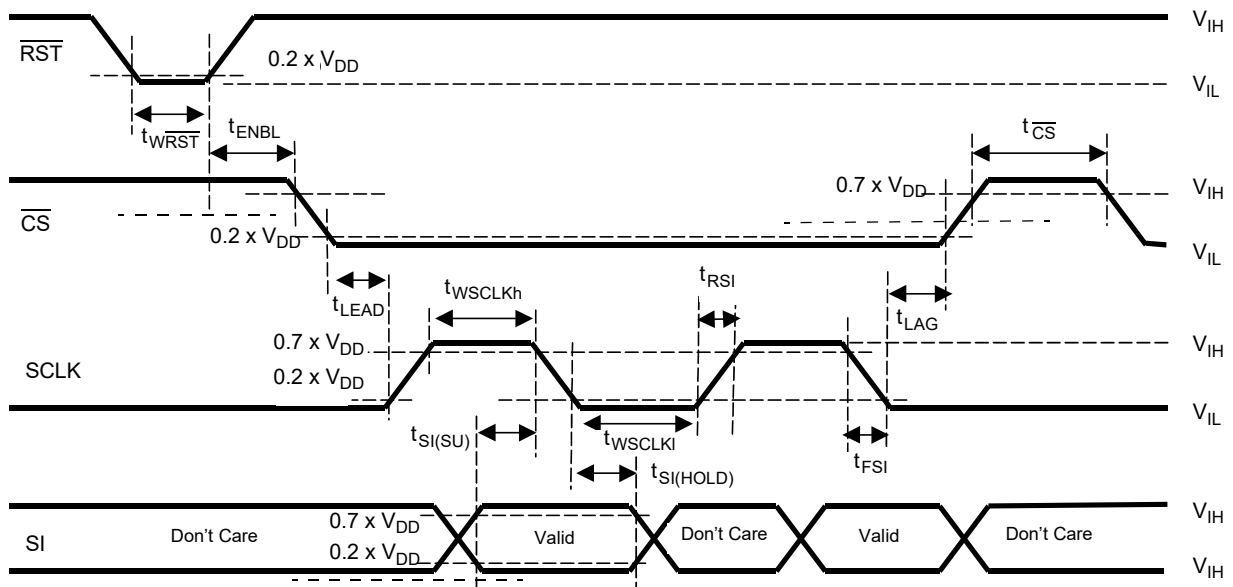

Figure 7. Input timing switching characteristics

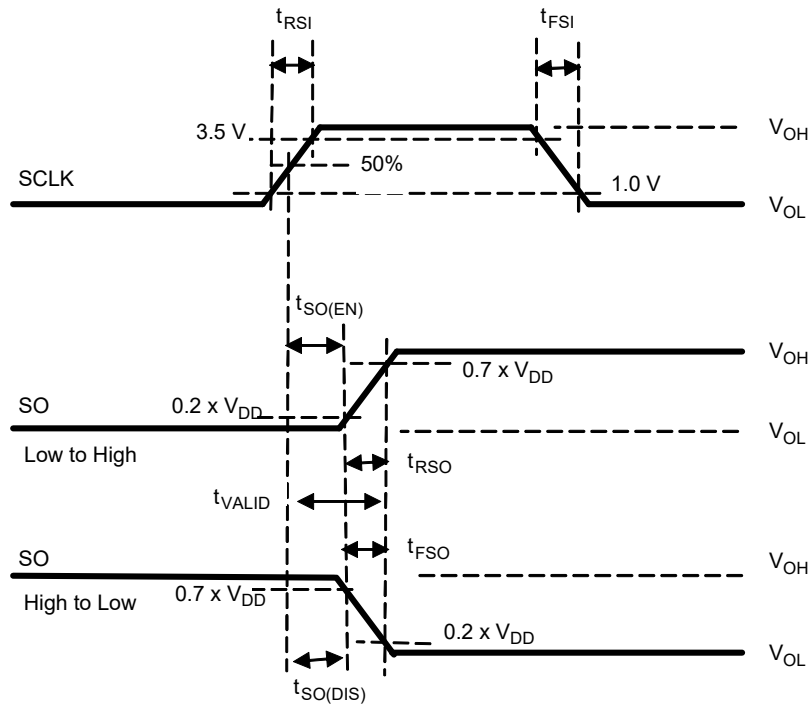

Figure 8. SCLK waveform and valid SO data delay time

Functional description

Introduction

The 33984 is a dual self-protected 4.0 mΩ silicon switch used to replace electromechanical relays, fuses, and discrete devices in power management applications. The 33984 is designed for harsh environments, and it includes self-recovery features. The device is suitable for loads with high inrush current, as well as motors and all types of resistive and inductive loads.

Programming, control, and diagnostics are implemented via the serial peripheral interface (SPI). A dedicated parallel input is available for alternate and pulse width modulation (PWM) control of each output. SPI-programmable fault trip thresholds allow the device to be adjusted for optimal performance in the application. The 33984 is packaged in a power-enhanced 12 mm x 12 mm non-leaded PQFN package with exposed tabs.

Functional pin description

OUTPUT CURRENT MONITORING (CSNS)

This pin is used to output a current proportional to the designated HS0-1 output. The current is fed into a ground-referenced resistor and its voltage is monitored by an MCU's A/D. The channel to be monitored is selected via the SPI. This pin can be tri-stated through the SPI.

WAKE (WAKE)

This pin is used to input a logic [1] signal so as to enable the watchdog timer function. An internal clamp protects this pin from high damaging voltages when the output is current limited with an external resistor. This input has a passive internal pull-down.

RESET ($\overline{\text{RST}}$)

This input pin is used to initialize the device configuration and fault registers, as well as place the device in a low-current Sleep mode. The pin also starts the watchdog timer when transitioning from logic Low to logic High. This pin should not be allowed to be logic High until V_{DD} is in regulation. This pin has a passive internal pull-down.

DIRECT IN 0 & 1 (INx)

This input pin is used to directly control the output HS0 and 1. This input has an active internal pull-down current source and requires CMOS logic levels. This input may be configured via the SPI.

FAULT STATUS ($\overline{\text{FS}}$)

This is an open drain configured output requiring an external pull-up resistor to V_{DD} for fault reporting. When a device fault condition is detected, this pin is active Low. Specific device diagnostic faults are reported via the SPI SO pin.

FAIL-SAFE INPUT (FSI)

The value of the resistance connected between this pin and ground determines the state of the outputs after a watchdog timeout occurs. Depending on the resistance value, either all outputs are OFF, ON, or the output HS0 only is ON. When the FSI pin is connected to GND, the watchdog circuit and fail-safe operation are disabled. This pin incorporates an active internal pull-up current source.

CHIP SELECT ($\overline{\text{CS}}$)

This input pin is connected to a chip select output of a master microcontroller (MCU). The MCU determines which device is addressed (selected) to receive data by pulling the $\overline{\text{CS}}$ pin of the selected device logic Low, enabling SPI communication with the device. Other unselected devices on the serial link having their CS pins pulled-up logic High disregard the SPI communication data sent. This pin incorporates an active internal pull-up current source.

SERIAL CLOCK (SCLK)

This input pin is connected to the MCU providing the required bit shift clock for SPI communication. It transitions one time per bit transferred at an operating frequency, f_{SPI} , defined by the communication interface. The 50 percent duty cycle CMOS-level serial clock signal is idle between command transfers. The signal is used to shift data into and out of the device. This input has an active internal pull-down current source.

SERIAL INPUT (SI)

This is a command data input pin connected to the SPI Serial Data Output of the MCU or to the SO pin of the previous device of a daisy chain of devices. The input requires CMOS logic-level signals and incorporates an active internal pull-down current source. Device control is facilitated by the input's receiving the MSB first of a serial 8-bit control command. The MCU ensures data is available upon the falling edge of SCLK. The logic state of SI present upon the rising edge of SCLK loads this bit command into the internal command shift register.

DIGITAL DRAIN VOLTAGE (VDD)

This is an external voltage input pin used to supply power to the SPI circuit. In the event V_{DD} is lost, an internal supply provides power to a portion of the logic, ensuring limited functionality of the device. All device configuration registers are reset.

SERIAL OUTPUT (SO)

This output pin is connected to the SPI Serial Data Input pin of the MCU or to the SI pin of the next device of a daisy chain of devices. This output remains tri-stated (high-impedance OFF condition) so long as the \overline{CS} pin of the device is logic HIGH. SO is only active when the \overline{CS} pin of the device is asserted logic Low. The generated SO output signals are CMOS logic levels. SO output data is available on the falling edge of SCLK and transitions immediately on the rising edge of SCLK.

POSITIVE POWER SUPPLY (VPWR)

This pin connects to the positive power supply and is the source input of operational power for the device. The VPWR pin is a backside surface mount tab of the package.

HIGH-SIDE OUTPUT 0 & 1 (HSx)

This pin protects 4.0 m Ω high-side power output to the load.

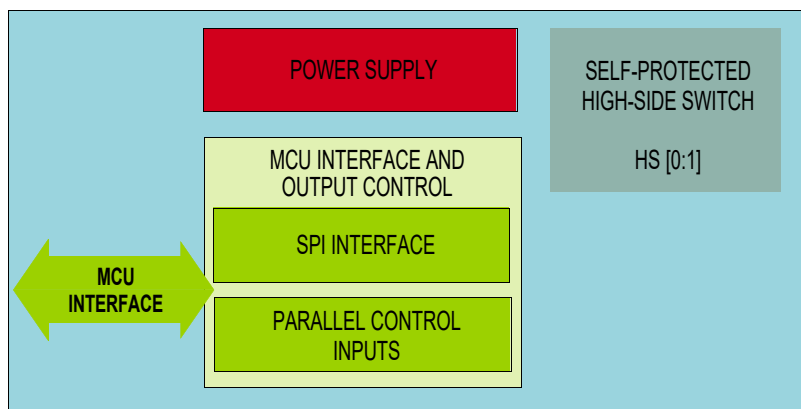
Functional internal block description**POWER SUPPLY**

The 33984 is designed to operate from 4.0 V to 28 V on the VPWR pin. Characteristics are provided from 6.0 V to 20 V for the device. The VPWR pin supplies power to internal regulator, analog, and logic circuit blocks. The V_{DD} supply is used for serial peripheral interface (SPI) communication in order to configure and diagnose the device. This IC architecture provides a low quiescent current sleep mode. Applying V_{PWR} and V_{DD} to the device places the device in the Normal mode. The device transits to Fail-safe mode in case of failures on the SPI (watchdog timeout).

HIGH-SIDE SWITCH: HS[0:1]

Those pins are the high-side outputs controlling multiple automotive loads with high inrush current, as well as motors and all types of resistive and inductive loads. This N-channel MOSFET with 4.0 m Ω RDS(ON), is self-protected and each N-channel presents extended diagnostics in order to detect load disconnections and short-circuit fault conditions. The HS[0:1] outputs are actively clamped during a turn-off of inductive loads.

MCU INTERFACE AND OUTPUT CONTROL

In Normal mode, the loads are controlled directly from the MCU through the SPI. With a dedicated SPI command, it is possible to independently turn on and off several loads are PWMed at the same frequency, and duty cycles with only one PWM signal. An analog feedback output provides a current proportional to each load current. The SPI is used to configure and to read the diagnostic status (faults) of the high-side output. The reported fault conditions are: open load, short-circuit to ground (OCLO-resistive and OCHI-severe short-circuit), thermal shutdown, and under/overvoltage.

In Fail-safe mode, the loads are controlled with dedicated parallel input pins. The device is configured in default mode.

Functional device operation

Operational modes

The 33984 has four operating modes: Sleep, Normal, Fault, and Fail-safe. [Table 6](#) summarizes details contained in succeeding paragraphs.

Table 6. Fail-safe operation and transitions to other 33984 modes

| Mode | $\overline{\text{FS}}$ | WAKE | RST | WDTO | Comments |
|-----------|------------------------|------|-----|------|--------------------------------------------------------------------------------------------------------------------------------------------------------------------------------------------------------------------------------------------------------------------------------------------------------------|
| Sleep | x | 0 | 0 | x | Device is in Sleep mode. All outputs are OFF. |
| Normal | 1 | x | 1 | No | Normal mode. Watchdog is active if enabled. |
| Fault | 0 | 1 | x | No | The device is currently in Fault mode. The faulted output(s) is (are) OFF. |
| | 0 | x | 1 | | |
| Fail-safe | 1 | 0 | 1 | Yes | Watchdog has timed out and the device is in Fail-safe mode. The outputs are as configured with the RFS resistor connected to FSI. $\overline{\text{RST}}$ and WAKE must be transitioned to logic [0] simultaneously to bring the device out of the Fail-safe mode or momentarily tied the FSI pin to ground. |
| | 1 | 1 | 1 | | |
| | 1 | 1 | 0 | | |

x = Don't care.

SLEEP MODE

The default mode of the 33984 is the Sleep mode. This is the state of the device after first applying battery voltage (V_{PWR}), prior to any I/O transitions. This is also the state of the device when the WAKE and $\overline{\text{RST}}$ are both logic [0]. In the Sleep mode, the output and all unused internal circuitry, such as the internal 5.0 V regulator, are off to minimize current draw. In addition, all SPI-configurable features of the device are as if set to logic [0]. The device transitions to the Normal or Fail-safe operating modes based on the WAKE and $\overline{\text{RST}}$ inputs as defined in [Table 6](#).

NORMAL MODE

The 33984 is in Normal mode when:

- V_{PWR} is within the normal voltage range.
- $\overline{\text{RST}}$ pin is logic [1].
- No fault has occurred.

FAIL-SAFE AND WATCHDOG

If the FSI input is not grounded, the watchdog timeout detection is active when either the WAKE or $\overline{\text{RST}}$ input pin transitions from logic [0] to logic [1]. The WAKE input is capable of being pulled up to V_{PWR} with a series of limiting resistance limits the internal clamp current according to the specification.

The watchdog timeout is a multiple of an internal oscillator and is specified in [Table 15](#). As long as the WD bit (D7) of an incoming SPI message is toggled within the minimum watchdog timeout period (WDTO), based on the programmed value of the WDR the device operates normally. If an internal watchdog timeout occurs before the WD bit, the device reverts to a Fail-safe mode until the device is reinitialized.

During the Fail-safe mode, the outputs are ON or OFF depending upon the resistor RFS connected to the FSI pin, regardless of the state of the various direct inputs and modes ([Table 7](#)). In this mode, the SPI register content is retained except for overcurrent high and low detection levels and timing, which are reset to their default value (SOCL, SOCH, and OCLT). Then the watchdog, overvoltage, overtemperature, and overcurrent circuitry (with default value) are fully operational.

Table 7. Output state during fail-safe mode

| RFS (k Ω) | High-side State |
|-------------------|-------------------------|
| 0 | Fail-safe mode Disabled |
| 6.0 | Both HS0 and HS1 OFF |
| 15 | HS0 ON, HS1 OFF |
| 30 | Both HS0 and HS1 ON |

The Fail-safe mode can be detected by monitoring the WDTO bit D2 of the WD register. This bit is logic [1] when the device is in Fail-safe mode. The device can be brought out of the Fail-safe mode by transitioning the WAKE and RST pins from logic [1] to logic [0] or forcing the FSI pin to logic [0]. [Table 6](#) summarizes the various methods for resetting the device from the latched Fail-safe mode. If the FSI pin is tied to GND, the watchdog Fail-safe operation is disabled.

LOSS OF V_{DD}

If the external 5.0 V supply is not within specification, or even disconnected, all register content is reset. The two outputs can still be driven by the direct inputs IN1:IN0. The 33984 uses the battery input to power the output MOSFET related current sense circuitry and any other internal logic providing fail-safe device operation with no V_{DD} supplied. In this state, the watchdog, overvoltage, overtemperature, and overcurrent circuitry are fully operational with default values.

FAULT MODE

The 33984 indicates the following faults as they occur by driving the $\overline{\text{FS}}$ pin to logic [0]:

- Overtemperature fault
- Open load fault
- Overcurrent fault (high and low)
- Overvoltage and undervoltage fault

The $\overline{\text{FS}}$ pin automatically returns to logic [1] when the fault condition is removed, except for overcurrent and in some cases undervoltage. Fault information is retained in the fault register and is available (and reset) via the SO pin during the first valid SPI communication (refer to [Table 17](#)).

Protection and diagnostic features

OVERTEMPERATURE FAULT (NON-LATCHING)

The 33984 incorporates overtemperature detection and shutdown circuitry in each output structure. Overtemperature detection is enabled when an output is in the ON state.

For the output, an overtemperature fault (OTF) condition results in the faulted output turning OFF until the temperature falls below the T_{SD(HYS)}. This cycle continues indefinitely until action is taken by the MCU to shut OFF the output, or until the offending load is removed. When experiencing this fault, the OTF fault bit is set in the status register and cleared after either a valid SPI read or a power reset of the device.

OVERVOLTAGE FAULT (NON-LATCHING)

The 33984 shuts down the output during an overvoltage fault (OVF) condition on the VPWR pin. The output remains in the OFF state until the overvoltage condition is removed. When experiencing this fault, the OVF fault bit is set in the bit OD1 and cleared after either a valid SPI read or a power reset of the device. The overvoltage protection and diagnostic can be disabled through the SPI (bit OV_dis).

UNDervOLTAGE SHUTDOWN (LATCHING OR NON-LATCHING)

The output(s) latches off at some battery voltage below 6.0 V. As long as the V_{DD} level stays within the normal specified range, the internal logic states within the device is sustained.

In the case where battery voltage drops below the undervoltage threshold (VPWRUV) output turns off, $\overline{\text{FS}}$ goes to logic [0], and the fault register UVF bit is set to 1.

Two cases need to be considered when the battery level recovers :

- If output(s) command is (are) low, $\overline{\text{FS}}$ goes to logic [1] but the UVF bit remains set to 1 until the next read operation.
- If the output command is ON, then $\overline{\text{FS}}$ remains at logic [0]. The output must be turned OFF and ON again to re-enable the state of output and release $\overline{\text{FS}}$. The UVF bit remains set to 1 until the next read operation.

The undervoltage protection can be disabled through the SPI (bit UV_dis = 1). In this case, the $\overline{\text{FS}}$ and UVF bits do not report any undervoltage fault condition and the output state is not changed as long as battery voltage does not drop any lower than 2.5 V.

OPEN LOAD FAULT (NON-LATCHING)

The 33984 incorporates open load detection circuitry on each output. Output open load fault (OLF) is detected and reported as a fault condition when this output is disabled (OFF). The open load fault is detected and latched into the status register after the internal gate voltage is pulled low enough to turn OFF the output. The OLF fault bit is set in the status register. If the open load fault is removed, the status register is cleared after reading the register.

The open load protection can be disabled through SPI (bit OL_dis). It is recommended to disable the open load detection circuitry (OL_dis bit sets to logic [1]) in case of permanent open load fault condition.

OVERCURRENT FAULT (LATCHING)

The device has eight programmable overcurrent low detection levels (I_{OCL}) and two programmable overcurrent high detection levels (I_{OCH}) for maximum device protection. The two selectable, simultaneously active overcurrent detection levels, defined by I_{OCH} and I_{OCL} , are illustrated in [Figure 6](#). The eight different overcurrent low detect levels (I_{OCL0} : I_{OCL7}) are likewise illustrated in [Figure 6](#).

If the load current level ever reaches the selected overcurrent low detect level and the overcurrent condition exceeds the programmed overcurrent time period (t_{OCx}), the device latches the effected output OFF. If at any time the current reaches the selected I_{OCH} level, then the device immediately latches the fault and turn OFF the output, regardless of the selected t_{OCL} driver. For both cases, the device output stays off indefinitely until the device is commanded OFF and then ON again.

REVERSE BATTERY

The output survives the application of reverse voltage as low as -16 V. Under these conditions, the output's gates are enhanced to keep the junction temperature less than 150 °C. The ON resistance of the output is fairly similar in the Normal mode. No additional passive components are required.

GROUND DISCONNECT PROTECTION

In the event the 33984 ground is disconnected from load ground, the device protects itself and safely turns OFF the output regardless the state of the output at the time of disconnection. A 10 k resistor needs to be added between the WAKE pin and the rest of the circuitry in order to ensure the device turns off in case of ground disconnect, and to prevent this pin from exceeding its maximum ratings.

Table 8. Device behavior in case of undervoltage

| High-side Switch (VPWR Battery Voltage)** | State | UV Enable IN = 0 (Falling VPWR) | UV Enable IN = 0 (Rising VPWR) | UV Enable IN*** = 1 (Falling VPWR) | UV Enable IN*** = 1 (Rising VPWR) | UV Disable IN = 0 (Falling or Rising VPWR) | UV Disable IN*** = 1 (Falling or Rising VPWR) |
|-------------------------------------------|----------------------------|---------------------------------|--------------------------------|------------------------------------|-----------------------------------|--------------------------------------------|-----------------------------------------------|
| VPWR > VPWRUV | Output State | OFF | OFF | ON | OFF | OFF | ON |
| | \overline{FS} State | 1 | 1 | 1 | 0 | 1 | 1 |
| | SPI Fault Register UVF Bit | 0 | 1 until next read | 0 | 1 | 0 | 0 |
| VPWRUV > VPWR > UVPOR | Output State | OFF | OFF | OFF | OFF | OFF | ON |
| | \overline{FS} State | 0 | 0 | 0 | 0 | 1 | 1 |
| | SPI Fault Register UVF Bit | 1 | 1 | 1 | 1 | 0 | 0 |
| UVPOR > VPWR > 2.5 V* | Output State | OFF | OFF | OFF | OFF | OFF | ON |
| | \overline{FS} State | 1 | 1 | 1 | 1 | 1 | 1 |
| | SPI Fault Register UVF Bit | 1 until next read | 1 | 1 until next read | 1 until next read | 0 | 0 |
| 2.5 V > VPWR > 0 V | Output State | OFF | OFF | OFF | OFF | OFF | OFF |
| | \overline{FS} State | 1 | 1 | 1 | 1 | 1 | 1 |
| | SPI Fault Register UVF Bit | 1 until next read | 1 until next read | 1 until next read | 1 until next read | 0 | 0 |

Table 8. Device behavior in case of undervoltage (continued)

| High-side Switch (VPWR Battery Voltage)** | State | UV Enable IN = 0 (Falling VPWR) | UV Enable IN = 0 (Rising VPWR) | UV Enable IN*** = 1 (Falling VPWR) | UV Enable IN*** = 1 (Rising VPWR) | UV Disable IN = 0 (Falling or Rising VPWR) | UV Disable IN*** = 1 (Falling or Rising VPWR) |
|-------------------------------------------|----------|---------------------------------|--------------------------------|------------------------------------|-----------------------------------|--------------------------------------------|-----------------------------------------------|
| | Comments | UV fault is not latched | UV fault is not latched | | UV fault is latched | | |

* Typical value; not guaranteed

** While VDD remains within specified range.

*** = IN is equivalent to IN direct input or IN_spi SPI input.

Logic commands and registers

SPI PROTOCOL DESCRIPTION

The SPI interface has a full duplex, three-wire synchronous data transfer with four I/O lines associated with it: Serial Clock (SCLK), Serial Input (SI), Serial Output (SO), and Chip Select (\overline{CS}). The SI/SO pins of the 33984 follow a first-in first-out (D7/D0) protocol with both input and output words transferring the most significant bit (MSB) first. All inputs are compatible with 5.0 V CMOS logic levels. The SPI lines perform the following functions:

SERIAL CLOCK (SCLK)

Serial clocks (SCLK) the internal shift registers of the 33984 device. The serial input (SI) pin accepts data into the input shift register on the falling edge of the SCLK signal while the serial output (SO) pin shifts data information out of the SO line driver on the rising edge of the SCLK signal. It is important the SCLK pin be in a logic low state whenever \overline{CS} makes any transition. For this reason, it is recommended the SCLK pin be in a logic [0] state whenever the device is not accessed (\overline{CS} logic [1] state). SCLK has an active internal pull-down, I_{DWN} . When \overline{CS} is logic [1], signals at the SCLK and SI pins are ignored and SO is tri-stated (high-impedance). See [Figure 9](#) and [Figure 10](#).

SERIAL INPUT (SI)

This is a serial interface (SI) command data input pin. SI instruction is read on the falling edge of SCLK. An 8-bit stream of serial data is required on the SI pin, starting with D7 to D0. The internal registers of the 33984 are configured and controlled using a 4-bit addressing scheme, as shown in [Table 9](#). Register addressing and configuration are described in [Table 10](#). The SI input has an active internal pull-down, I_{DWN} .

SERIAL OUTPUT (SO)

The SO data pin is a tri-stateable output from the shift register. The SO pin remains in a high-impedance state until the \overline{CS} pin is put into a logic [0] state. The SO data is capable of reporting the status of the output, the device configuration, and the state of the key inputs. The SO pin changes states on the rising edge of SCLK and reads out on the falling edge of SCLK. Fault and Input Status descriptions are provided in [Table 6](#).

CHIP SELECT (\overline{CS})

The \overline{CS} pin enables communication with the master microcontroller (MCU). When this pin is in a logic [0] state, the device is capable of transferring information to, and receiving information from, the MCU. The 33984 device latches in data from the Input shift registers to the addressed registers on the rising edge of \overline{CS} . The device transfers status information from the power output to the shift register on the falling edge of \overline{CS} . The SO output driver is enabled when \overline{CS} is logic [0]. \overline{CS} should transition from a logic [1] to a logic [0] state only when SCLK is a logic [0]. \overline{CS} has an active internal pull-up, I_{UP} .

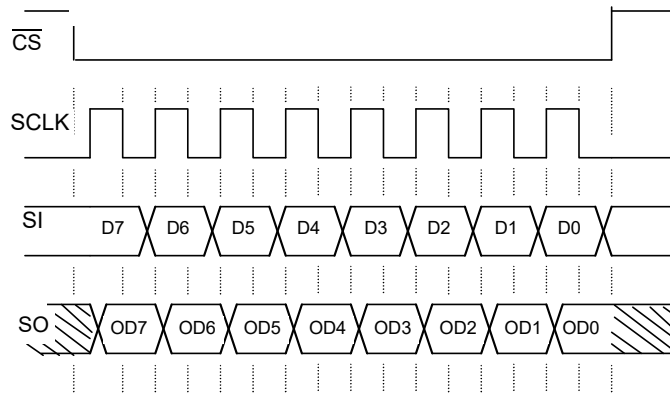

- NOTES 1. \overline{RST} is in a logic 1 state during the above operation.
- Notes 1. \overline{RST} is a logic [1] state during the above operation.
 2. D7:D0 relate to the most recent ordered entry of data into the device.
 3. OD7:OD0 relate to the first 8 bits of ordered fault and status data out of the device.

Figure 9. Single 8-Bit Word SPI Communication

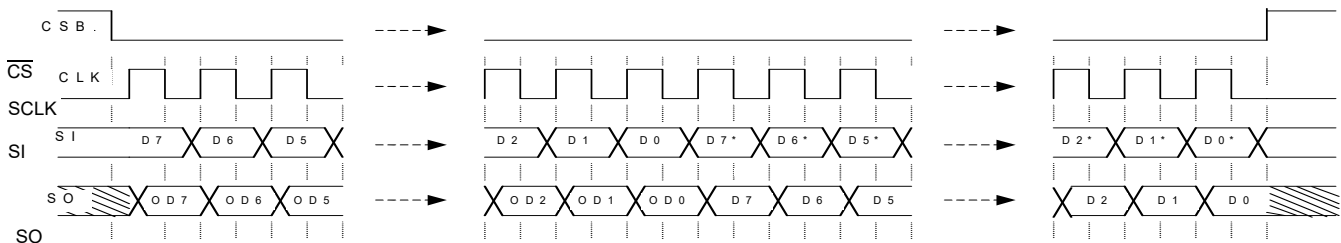

- Notes 1. \overline{RST} is a logic [1] state during the above operation.
 2. D7:D0 relate to the most recent ordered entry of data into the device.
 3. D7*:D0* relate to the previous 8 bits (last command word) of data was previously shifted into the device.
 4. OD7:OD0 relate to the first 8 bits of ordered fault and status data out of the device.

Figure 10. Multiple 8-bit word SPI communication

SERIAL INPUT COMMUNICATION

SPI communication is accomplished using 8-bit messages. A message is transmitted by the MCU starting with the MSB, D7, and ending with the LSB, D0 (Table 9). Each incoming command message on the SI pin can be interpreted using the following bit assignments: the MSB (D7) is the watchdog bit and in some cases a register address bit common to both outputs or specific to an output; the next three bits, D6:D4, are used to select the command register; and the remaining four bits, D3:D0, are used to configure and control the outputs and their protection features.

Multiple messages can be transmitted in succession to accommodate those applications where daisy chaining is desirable, or to confirm transmitted data, as long as the messages are all multiples of eight bits. Any attempt made to latch in a message is not eight bits is ignored.

The 33984 has defined registers, which are used to configure the device and to control the state of the output. Table 10, summarizes the SI registers. The registers are addressed via D6:D4 of the incoming SPI word (Table 9).

Table 9. SI message bit assignment

| Bit Sig | SI Msg Bit | Message Bit Description |
|---------|------------|--------------------------------------------------------------------------------------------------------------|
| MSB | D7 | Register address bit for output selection. Also used for watchdog: toggled to satisfy watchdog requirements. |
| | D6:D4 | Register address bits. |
| | D3:D1 | Used to configure the inputs, outputs, and the device protection features and SO status content. |
| LSB | D0 | Used to configure the inputs, outputs, and the device protection features and SO status content. |

Table 10. Serial input address and configuration bit map

| SI Register | Serial Input Data | | | | | | | |
|-------------|-------------------|----|----|----|------------------------------|-------------|------------------------------|---------|
| | D7 | D6 | D5 | D4 | D3 | D2 | D1 | D0 |
| STATR | s | 0 | 0 | 0 | 0 | SOA2 | SOA1 | SOA0 |
| OCR | x | 0 | 0 | 1 | CSNS1 $\overline{\text{EN}}$ | IN1_SPI | CSNS0 $\overline{\text{EN}}$ | IN0_SPI |
| SOCHLR | s | 0 | 1 | 0 | SOCHs | SOCL2s | SOCL1s | SOCL0s |
| CDTOLR | s | 0 | 1 | 1 | OL_DIS s | CD_DIS s | OCLT1s | OCLT0s |
| DICR | s | 1 | 0 | 0 | FAST SR s | CSNS high s | IN DIS s | A/Os |
| OSDR | 0 | 1 | 0 | 1 | 0 | OSD2 | OSD1 | OSD0 |
| WDR | 1 | 1 | 0 | 1 | 0 | 0 | WD1 | WD0 |
| NAR | 0 | 1 | 1 | 0 | 0 | 0 | 0 | 0 |
| UOVR | 1 | 1 | 1 | 0 | 0 | 0 | UV_dis | OV_dis |
| TEST | x | 1 | 1 | 1 | NXP Internal Use (Test) | | | |

x = Don't care.

s (SOA3 bit) = Selection of output: logic [0] = HS0, logic [1] = HS1.

DEVICE REGISTER ADDRESSING

The following section describes the possible register addresses and their impact on device operation.

Address x000—Status Register (STATR)

The STATR register is used to read the device status and the various configuration register contents without disrupting the device operation or the register contents. The register bits D2:D0, determine the content of the first eight bits of SO data. When register content is specific to one of the two outputs, bit D7 is used to select the desired output (SOA3). In addition to the device status, this feature provides the ability to read the content of the OCR, SOCHLR, CDTOLR, DICR, OSDR, WDR, NAR, and UOVR registers. (Refer to the section entitled [Serial Output Communication \(Device Status Return Data\)](#)).

Address x001—Output Control Register (OCR)

The OCR register allows the MCU to control the outputs through the SPI. Incoming message bit D0 reflects the desired states of the high-side output HS0 (IN0_SPI): a logic [1] enables the output switch and a logic [0] turns it OFF. A logic [1] on message bit D1 enables the Current Sense (CSNS) pin. Similarly, incoming message bit D2 reflects the desired states of the high-side output HS1 (IN1_SPI): logic [1] enables the output switch and a logic [0] turns it OFF. A logic [1] on message bit D3 enables the CSNS pin. In the event the current sense is enabled for both outputs, the current is summed. Bit D7 is used to feed the watchdog if enabled.

Address x010— Select Overcurrent High and Low Register (SOCHLR)

The SOCHLR register allows the MCU to configure the output overcurrent low and high detection levels, respectively. Each output is independently selected for configuration based on the state of the D7 bit; a write to this register when D7 is logic [0] configures the current detection levels for the HS0. Similarly, if D7 is logic [1] when this register is written, HS1 is configured. Each output can be configured to different levels. In addition to protecting the device, this slow blow fuse emulation feature can be used to optimize the load requirements matching system characteristics. Bits D2:D0 set the overcurrent low detection level to one of eight possible levels, as shown in [Table 11](#). Bit D3 sets the overcurrent high detection level to one of two levels, which is described in [Table 12](#).

Table 11. Overcurrent low detection levels

| SOCL2 (D2) | SOCL1 (D1) | SOCL0 (D0) | Overcurrent Low Detection (Amperes) |
|------------|------------|------------|-------------------------------------|
| 0 | 0 | 0 | 25 |
| 0 | 0 | 1 | 22.5 |
| 0 | 1 | 0 | 20 |
| 0 | 1 | 1 | 17.5 |
| 1 | 0 | 0 | 15 |
| 1 | 0 | 1 | 12.5 |
| 1 | 1 | 0 | 10 |
| 1 | 1 | 1 | 7.5 |

Table 12. Overcurrent high detection levels

| SOCH (D3) | Overcurrent High Detection (Amperes) |
|-----------|--------------------------------------|
| 0 | 100 |
| 1 | 75 |

Address x011—Current Detection Time and Open Load Register (CDTOLR)

The CDTOLR register is used by the MCU to determine the amount of time the device allows an overcurrent low condition before output latches OFF occurs. Each output is independently selected for configuration based on the state of the D7 bit. A write to this register when bit 7 is logic [0] configures the timeout for the HS0. Similarly, if D7 is logic [1] when this register is written, then HS1 is configured. Bits D1:D0 allow the MCU to select one of four fault blanking times defined in [Table 13](#). Note that these timeouts apply only to the overcurrent low detection levels. If the selected overcurrent high level is reached, the device latches off within 20 μ s.

Table 13. Overcurrent Low Detection Blanking Time

| OCLT[1:0] | Timing |
|-----------|-------------|
| 00 | 155 ms |
| 01 | 10 ms |
| 10 | 1.2 ms |
| 11 | 150 μ s |

A logic [1] on bit D2 disables the overcurrent low (CD_dis) detection timeout feature. A logic [1] on bit D3 disables the open load (OL) detection feature.

Address x100—Direct Input Control Register (DICR)

The DICR register is used by the MCU to enable, disable, or configure the direct IN pin control of each output. Each output is independently selected for configuration based on the state of bit D7. A write to this register when bit D7 is logic [0] configures the direct input control for the HS0. Similarly, if D7 is logic [1] when this register is written, then HS1 is configured.

A logic [0] on bit D1 enables the output for direct control by the IN pin. A logic [1] on bit D1 disables the output from direct control. While addressing this register, if the input was enabled for direct control, a logic [1] for the D0 bit results in a Boolean AND of the IN pin with its corresponding D0 message bit when addressing the OCR register. Similarly, a logic [0] on the D0 pin results in a Boolean OR of the IN pin with the corresponding message bits when addressing the OCR register.

The DICR register is useful if there is a need to independently turn on and off several loads are PWMed at the same frequency and duty cycle with only one PWM signal. This type of operation can be accomplished by connecting the pertinent direct IN pins of several devices to a PWM output port from the MCU and configuring each of the outputs to be controlled via their respective direct IN pin. The DICR is then used to Boolean AND the direct IN(s) of each of the outputs with the dedicated SPI bit also controls the output. Each configured SPI bit can now be used to enable and disable the common PWM signal from controlling its assigned output.

A logic [1] on bit D2 is used to select the high ratio (C_{SR1} , 1/41000) on the CSNS pin for the selected output. The default value [0] is used to select the low ratio (C_{SR0} , 1/20500). A logic [1] on bit D3 is used to select the high speed slew rate for the selected output. The default value [0] corresponds to the low speed slew rate.

Address 0101—Output Switching Delay Register (OSDR)

The OSDR register configures the device with a programmable time delay active during Output ON transitions initiated via the SPI (not via direct input).

A write to this register configures both outputs for different delay. Whenever the input is commanded to transition from logic [0] to logic [1], both outputs are held OFF for the time delay configured in the OSDR. The programming of the contents of this register have no effect on device Fail-safe Mode operation. The default value of the OSDR register is 000, equating to no delay. This feature allows the user a way to minimize inrush currents, or surges, thereby allowing loads to be switched ON with a single command. There are eight selectable output switching delay times ranging from 0 ms to 525 ms. Refer to [Table 14](#).

Table 14. Switching delay

| OSD[2:0] (D2:D0) | Turn ON Delay (ms) HS0 | Turn ON Delay (ms) HS1 |
|------------------|------------------------|------------------------|
| 000 | 0 | 0 |
| 001 | 0 | 75 |
| 010 | 150 | 150 |
| 011 | 150 | 225 |
| 100 | 300 | 300 |
| 101 | 300 | 375 |
| 110 | 450 | 450 |
| 111 | 450 | 525 |

Address 1101—Watchdog Register (WDR)

The WDR register is used by the MCU to configure the watchdog timeout. Watchdog timeout is configured using bits D1:D0. When D1:D0 bits are programmed for the desired watchdog timeout period, the WD bit (D7) should be toggled as well, ensuring the new timeout period is programmed at the beginning of a new count sequence. Refer to [Table 15](#).

Table 15. Watchdog Timeout

| WD[1:0] (D1:D0) | Timing (ms) |
|-----------------|-------------|
| 00 | 620 |
| 01 | 310 |
| 10 | 2500 |
| 11 | 1250 |

Address 0110—No Action Register (NAR)

The NAR register can be used to no-operation fill SPI data packets in a daisy chain SPI configuration. This allows devices to not be affected by commands being clocked over a daisy chained SPI configuration, and by toggling the WD bit (D7), the watchdog circuitry continues to be reset while no programming or data readback functions are being requested from the device.

Address 1110—Undervoltage/Overvoltage Register (UOVR)

The UOVR register can be used to disable or enable overvoltage and/or undervoltage protection. By default (logic [0]), both protections are active. When disabled, an undervoltage or overvoltage condition fault is not reported in the output fault register.

Address x111—TEST

The TEST register is reserved for test and is not accessible with SPI during normal operation.

SERIAL OUTPUT COMMUNICATION (DEVICE STATUS RETURN DATA)

When the \overline{CS} pin is pulled low, the output status register is loaded. Meanwhile, the data is clocked out \overline{MSB} - (OD7-) first as the new message data is clocked into the SI pin. The first eight bits of data clocking out of the SO, and following a \overline{CS} transition, are dependant upon the previously written SPI word.

Any bits clocked out of the SO pin after the first eight is representative of the initial message bits clocked into the SI pin since the \overline{CS} pin first transitioned to a logic [0]. This feature is useful for daisy chaining devices as well as message verification.

A valid message length is determined following a \overline{CS} transition of logic [0] to logic [1]. If there is a valid message length, the data is latched into the appropriate registers. A valid message length is a multiple of eight bits. At this time, the SO pin is tri-stated and the fault status register is now able to accept new fault status information.

The output status register correctly reflects the status of the STATR-selected register data at the time the \overline{CS} is pulled to a logic [0] during SPI communication and/or for the period of time since the last valid SPI communication, with the following exceptions:

- The previous SPI communication was determined to be invalid. In this case, the status is reported as though the invalid SPI communication never occurred.
- Battery transients below 6.0 V resulting in an undervoltage shutdown of the outputs may result in incorrect data loaded into the status register. The SO data transmitted to the MCU during the first SPI communication following an undervoltage V_{PWR} condition should be ignored.
- The \overline{RST} pin transition from a logic [0] to logic [1] while the WAKE pin is at logic [0] may result in incorrect data loaded into the status register. The SO data transmitted to the MCU during the first SPI communication following this condition should be ignored.

SERIAL OUTPUT BIT ASSIGNMENT

The 8 bits of serial output data depend on the previous serial input message, as explained in the following paragraphs. [Table 16](#) summarizes the SO register content.

Bit OD7 reflects the state of the watchdog bit (D7) addressed during the prior communication. The value of the previous D7 determines which output the status information applies to for the Fault (FLTR), SOCHLR, CDTOLR, and DICR registers. SO data represents information ranging from fault status to register contents, user selected by writing to the STATR bits D2:D0. Note that the SO data continues to reflect the information for each output (depending on the previous D7 state) was selected during the most recent STATR write until changed with an updated STATR write.

Previous Address SOA[2:0]=000

If the previous three MSBs are 000, bits OD6:OD0 reflects the current state of the Fault register (FLTR) corresponding to the output previously selected with the bit OD7 ([Table 17](#)).

Previous Address SOA[2:0]=001

Data in bits OD1:OD0 contain CSNS0 \overline{EN} and IN0_SPI programmed bits, respectively. Data in bits OD3:OD2 contain CSNS0 \overline{EN} and IN0_SPI programmed bits, respectively.

Previous Address SOA[2:0]=010

The data in bit OD3 contain the programmed overcurrent high detection level (refer to [Table 12](#)), and the data in bits OD2:OD0 contain the programmed overcurrent low detection levels (refer to [Table 13](#)).

Table 16. Serial output bit map description

| Previous STATR D7, D2, D1, D0 | | | | Serial Output Returned Data | | | | | | | |
|----------------------------------|------|------|------|-----------------------------|------|-------------------|-------------------|-----------------------------|--------------------|-----------------------|--------------------|
| SOA3 | SOA2 | SOA1 | SOA0 | OD7 | OD6 | OD5 | OD4 | OD3 | OD2 | OD1 | OD0 |
| s | 0 | 0 | 0 | s | OTFs | OCHF _s | OCLF _s | OLF _s | UVF | OVF | FAULT |
| x | 0 | 0 | 1 | x | 0 | 0 | 1 | CSNS1 \overline{EN} | IN1_SPI | CSNS0 \overline{EN} | IN0_SPI |
| s | 0 | 1 | 0 | s | 0 | 1 | 0 | SOCH _s | SOCL2 _s | SOCL1 _s | SOCL0 _s |
| s | 0 | 1 | 1 | s | 0 | 1 | 1 | OL_DIS s | CD_DIS s | OCLT1 _s | OCLT0 _s |
| s | 1 | 0 | 0 | s | 1 | 0 | 0 | FAST SR s | CSNS High s | IN DIS s | A/O _s |
| 0 | 1 | 0 | 1 | 0 | 1 | 0 | 1 | FSM_HS0 | OSD2 | OSD1 | OSD0 |
| 1 | 1 | 0 | 1 | 1 | 1 | 0 | 1 | FSM_HS1 | WDTO | WD1 | WD0 |
| 0 | 1 | 1 | 0 | 0 | 1 | 1 | 0 | IN1 Pin | IN0 Pin | FSI Pin | WAKE Pin |
| 1 | 1 | 1 | 0 | 1 | 1 | 1 | 0 | – | – | UV_dis | OV_dis |
| x | 1 | 1 | 1 | – | – | – | – | See Table 2 | – | – | – |

s = Selection of output: Logic [0] = HS0, Logic [1] = HS1.

x = Don't care.

Table 17. Fault register

| OD7 | OD6 | OD5 | OD4 | OD3 | OD2 | OD1 | OD0 |
|-----|-----|-------------------|-------------------|------------------|-----|-----|-------|
| s | OTF | OCHF _s | OCLF _s | OLF _s | UVF | OVF | FAULT |

OD7 (s) = Selection of Output: Logic [0] = HS0, Logic [1] = HS1.

OD6 (OTF) = Overtemperature Flag.

OD5 (OCHF_s) = Overcurrent High Flag. (This fault is latched.)

OD4 (OCLF_s) = Overcurrent Low Flag. (This fault is latched.)

OD3 (OLF_s) = Open Load Flag.

OD2 (UVF) = Undervoltage Flag. (This fault is latched or not latched.)

OD1 (OVF) = Overvoltage Flag.

OD0 (FAULT) = This flag reports a fault and is reset by a read operation.

FAULT report of any fault on HS0 or HS1

Note The \overline{FS} pin reports a fault. For latched faults, this pin is reset by a new Switch ON command (via SPI or direct input IN).

Previous Address SOA[2:0]=011

Data returned in bits OD1 and OD0 are current values for the overcurrent fault blanking time, illustrated in [Table 13](#). Bit OD2 reports if the overcurrent detection timeout feature is active. OD3 reports if the open load circuitry is active.

Previous Address SOA[2:0]=100

The returned data contain the programmed values in the DICR.

Previous Address SOA[2:0]=101

- SOA3 = 0. The returned data contain the programmed values in the OSDR. Bit OD3 (FSM_HS0) reflects the state of the output HS0 in the Fail-safe mode after a watchdog timeout occurs.
- SOA3 = 1. The returned data contain the programmed values in the WDR. Bit OD2 (WDTO) reflects the status of the watchdog circuitry. If WDTO bit is logic [1], the watchdog has timed out and the device is in Fail-safe mode. If WDTO is logic [0], the device is in Normal mode (assuming the device is powered and not in Sleep mode), with the watchdog either enabled or disabled. Bit OD3 (FSM_HS1) reflects the state of the output HS1 in the Fail-safe mode after a watchdog timeout occurs.

Previous Address SOA[2:0]=110

- SOA3 = 0. OD3:OD0 return the state of the IN1, IN0, FSI, and WAKE pins, respectively ([Table 18](#)).

Table 18. Pin Register

| OD3 | OD2 | OD1 | OD0 |
|---------|---------|---------|----------|
| IN1 Pin | IN0 Pin | FSI Pin | WAKE Pin |

- SOA3 = 1. The returned data contain the programmed values in the UOVR. Bit OD1 reflects the state of the undervoltage protection and bit OD0 reflects the state of the overvoltage protection. Refer to [Table 16](#).

Previous Address SOA[2:0]=111

Null Data. No previous register Read Back command received, so bits OD2:OD0 are null, or 000.

Output current monitoring

This section relates to the output current monitoring for 33984, Dual 4.0 mΩ High-side Switch. This device is a self-protected silicon switch used to replace electromechanical relays, fuses, and discrete circuits in power management applications. The MC33984 features a current recopy which is proportional to the load current. It can be configured between two ratios via the SPI (CSR0 and CSR1).

This section presents the current recopy tolerance of the device and the improvement of this feature with the calibration practice.

CURRENT RECOPY TOLERANCE

The Current Sense Ratio Accuracies described in [Current Sense Ratio \(CSR₀\) Accuracy](#) (CSR0_ACC and CSR1_ACC) take into account:

- part to part deviation due to manufacturing,
- ambient temperature derating (from -40 °C to 125 °C),
- battery voltage range (from 9.0 V to 16 V).

Thanks to statistical data analysis performed on 3 production lots (initial testing only), the effect of each contributor has been demonstrated. [Figure 12](#) shows the CSR0 tolerance in function to three previous listed contributors in comparison to the minimum and maximum specified values.

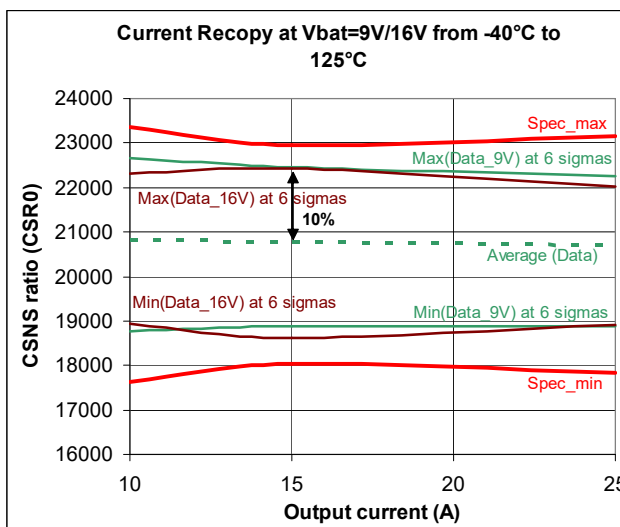

Figure 12. CSR0 ratio deviation in function all contributors

Lower VPWR Voltage causes more error. 9.0 V corresponding to the worst case. [Figure 13](#) shows the CSR0 tolerance without battery variation effect.

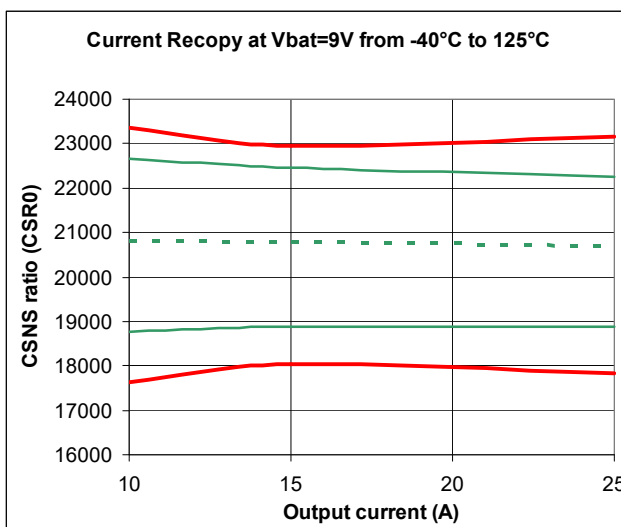

Figure 13. CSR0 ratio deviation in function manufacturing and temperature

The main contributor is the manufacturing deviation, as described in [Figure 14](#). At 15 A of output current, the tolerance is about 8.5% versus 10% when all contributors are considered.

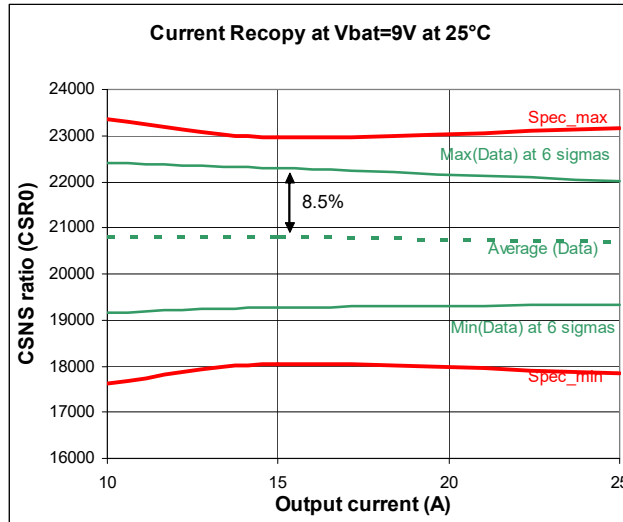

Figure 14. CSRO ratio deviation in function manufacturing

PART CALIBRATION

With a calibration strategy, the part to part contribution can be removed. An experiment was done on low output current values (below 5.0 A). The relative CSRO deviation based on only one calibration point per output (5.0 A, VPWR =16 V at 25°C) has been performed on three production lots. Those parts have tested at initial and after high temperature operating Life test in order to take into account the ageing of devices. [Table 19](#) summaries test results covering 99.74% of parts.

Table 19. CSRO precision for several output current values with one calibration point at 5.0 A

| CSRO ratio | Min | Max |
|------------|-------|------|
| 0.5 A | -25% | 25% |
| 1.0 A | -12% | 12% |
| 2.5 A | -8.0% | 8.0% |
| 5.0 A | -5.0% | 5.0% |

Packaging

Soldering information

SOLDERING INFORMATION

The 33984 is packaged in a surface mount power package (PQFN), intended to be soldered directly on the printed circuit board. The AN2467 provides guidelines for Printed Circuit Board design and assembly.

Package dimensions

For the most current revision of the package, visit www.nxp.com and perform a keyword search on 98ARL10521D and 98ASA00815D. Dimensions shown are provided for reference ONLY.

Table 20. Part keywords

| Suffix | Package outline drawing number |
|---------------|---------------------------------------|
| CHFK | 98ARL10521D |
| EHFK | 98ASA00815D |

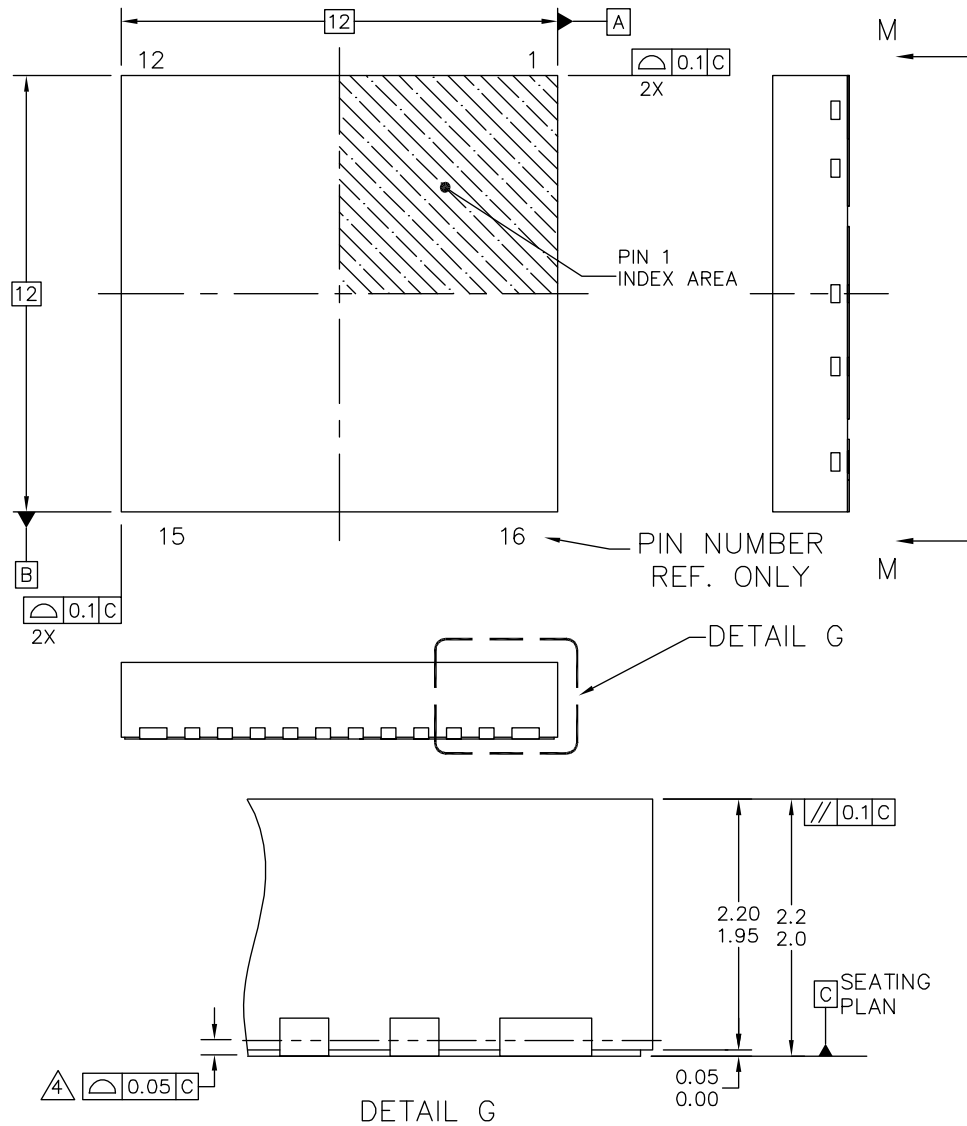

| | | |
|---------------------------------------------------------------------------------------------|---------------------------|----------------------------|
| © FREESCALE SEMICONDUCTOR, INC. ALL RIGHTS RESERVED. | MECHANICAL OUTLINE | PRINT VERSION NOT TO SCALE |
| TITLE: POWER QUAD FLAT NON-LEADED PACKAGE (PWR QFN) 16 TERMINAL, 0.9 PITCH(12X12X2.1) | DOCUMENT NO: 98ARL10521D | REV: D |
| | CASE NUMBER: 1402-03 | 21 SEP 2011 |
| STANDARD: NON-JEDEC | | |

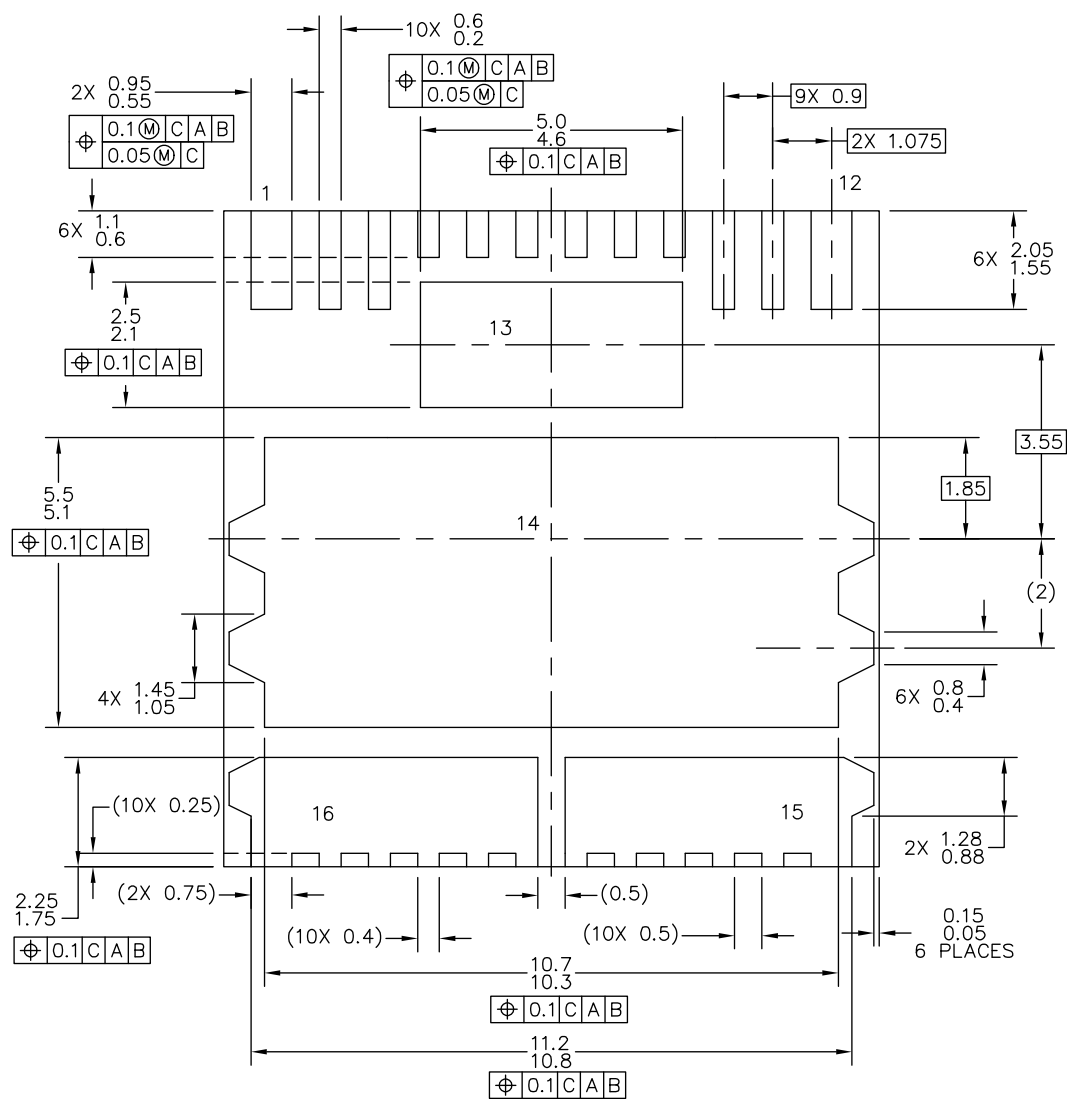

VIEW M-M

| | | | |
|---------------------------------------------------------------------------------------------|---------------------------|----------------------------|--|
| © FREESCALE SEMICONDUCTOR, INC. ALL RIGHTS RESERVED. | MECHANICAL OUTLINE | PRINT VERSION NOT TO SCALE | |
| TITLE: POWER QUAD FLAT NON-LEADED PACKAGE (PWR QFN) 16 TERMINAL, 0.9 PITCH(12X12X2.1) | DOCUMENT NO: 98ARL10521D | REV: D | |
| | CASE NUMBER: 1402-03 | 21 SEP 2011 | |
| | STANDARD: NON-JEDEC | | |

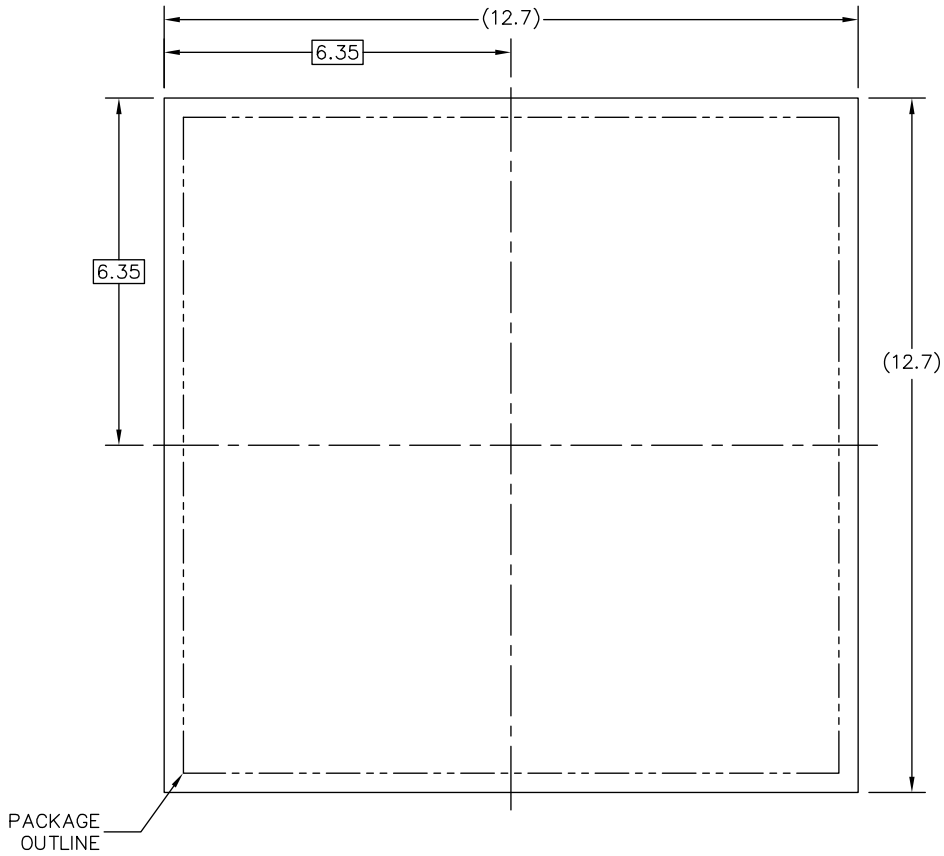

PCB DESIGN GUIDELINES – SOLDER MASK OPENING PATTERN 1

THIS SHEET SERVES ONLY AS A GUIDELINE TO HELP DEVELOP A USER SPECIFIC SOLUTION. DEVELOPMENT EFFORT WILL STILL BE REQUIRED BY END USERS TO OPTIMIZE PCB MOUNTING PROCESSES AND BOARD DESIGN IN ORDER TO MEET INDIVIDUAL / SPECIFIC REQUIREMENTS.

| | | | |
|---------------------------------------------------------------------------------------------|---------------------------|----------------------------|-------------|
| © FREESCALE SEMICONDUCTOR, INC. ALL RIGHTS RESERVED. | MECHANICAL OUTLINE | PRINT VERSION NOT TO SCALE | |
| TITLE: POWER QUAD FLAT NON-LEADED PACKAGE (PWR QFN) 16 TERMINAL, 0.9 PITCH(12X12X2.1) | | DOCUMENT NO: 98ARL10521D | REV: D |
| | | CASE NUMBER: 1402-03 | 21 SEP 2011 |
| | | STANDARD: NON-JEDEC | |

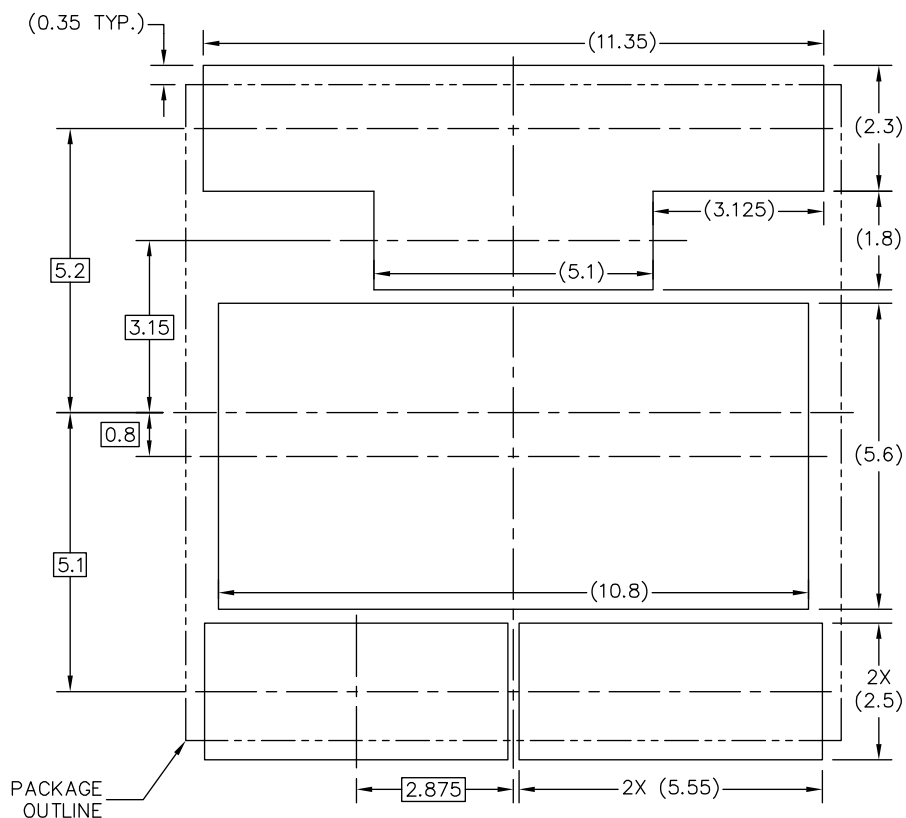

PCB DESIGN GUIDELINES – SOLDER MASK OPENING PATTERN 2

THIS SHEET SERVES ONLY AS A GUIDELINE TO HELP DEVELOP A USER SPECIFIC SOLUTION. DEVELOPMENT EFFORT WILL STILL BE REQUIRED BY END USERS TO OPTIMIZE PCB MOUNTING PROCESSES AND BOARD DESIGN IN ORDER TO MEET INDIVIDUAL / SPECIFIC REQUIREMENTS.

| | | | |
|---------------------------------------------------------------------------------------------|---------------------------|----------------------------|--|
| © FREESCALE SEMICONDUCTOR, INC. ALL RIGHTS RESERVED. | MECHANICAL OUTLINE | PRINT VERSION NOT TO SCALE | |
| TITLE: POWER QUAD FLAT NON-LEADED PACKAGE (PWR QFN) 16 TERMINAL, 0.9 PITCH(12X12X2.1) | DOCUMENT NO: 98ARL10521D | REV: D | |
| | CASE NUMBER: 1402-03 | 21 SEP 2011 | |
| | STANDARD: NON-JEDEC | | |

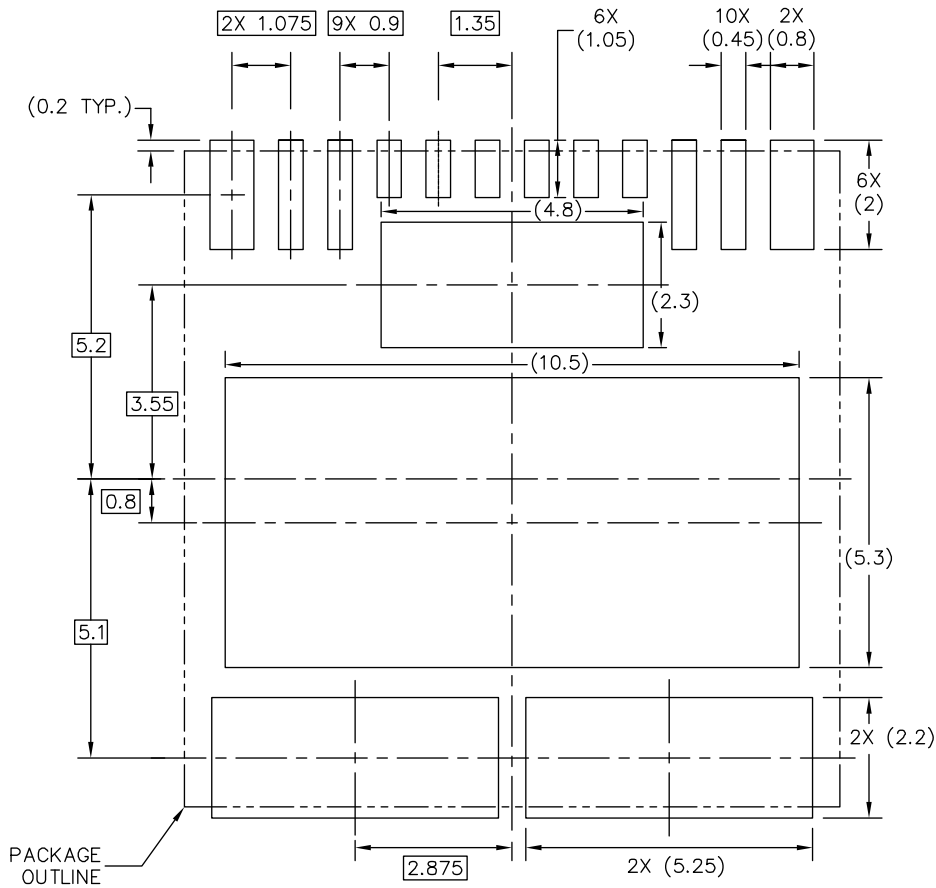

PCB CU GUIDELINES – I/O PADS & SOLDERABLE AREAS

THIS SHEET SERVES ONLY AS A GUIDELINE TO HELP DEVELOP A USER SPECIFIC SOLUTION. DEVELOPMENT EFFORT WILL STILL BE REQUIRED BY END USERS TO OPTIMIZE PCB MOUNTING PROCESSES AND BOARD DESIGN IN ORDER TO MEET INDIVIDUAL / SPECIFIC REQUIREMENTS.

| | | | |
|---------------------------------------------------------------------------------------------|---------------------------|----------------------------|--|
| © FREESCALE SEMICONDUCTOR, INC. ALL RIGHTS RESERVED. | MECHANICAL OUTLINE | PRINT VERSION NOT TO SCALE | |
| TITLE: POWER QUAD FLAT NON-LEADED PACKAGE (PWR QFN) 16 TERMINAL, 0.9 PITCH(12X12X2.1) | DOCUMENT NO: 98ARL10521D | REV: D | |
| | CASE NUMBER: 1402-03 | 21 SEP 2011 | |
| | STANDARD: NON-JEDEC | | |

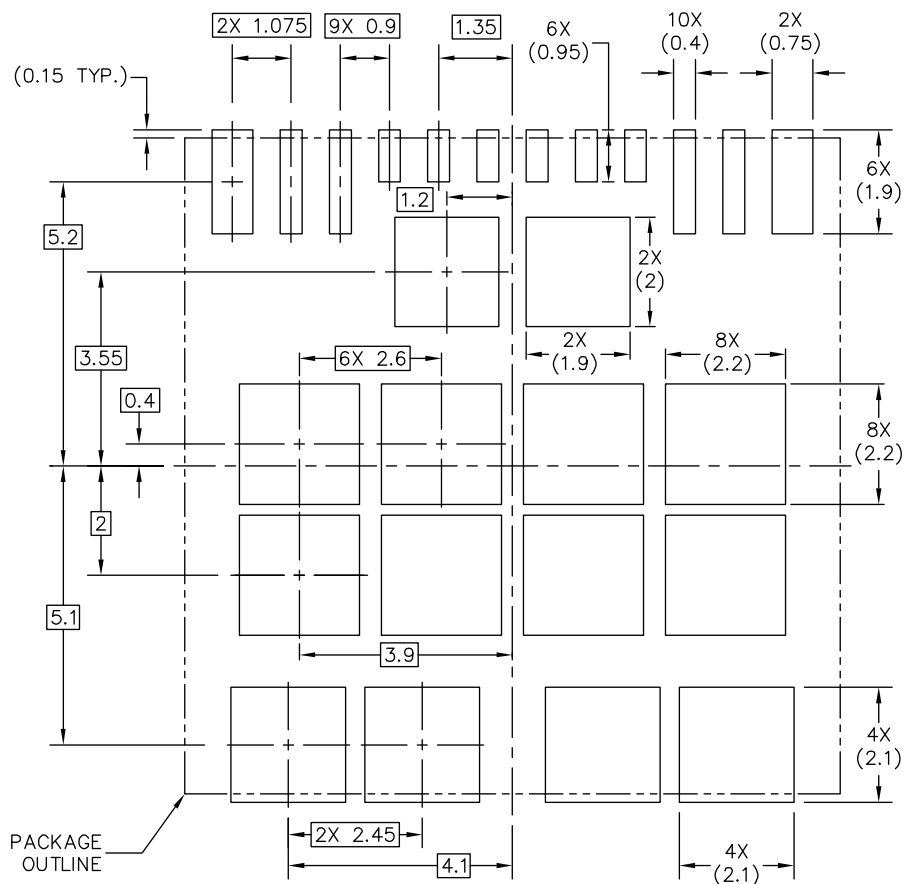

SOLDER PASTE STENCIL GUIDELINES

THIS SHEET SERVES ONLY AS A GUIDELINE TO HELP DEVELOP A USER SPECIFIC SOLUTION. DEVELOPMENT EFFORT WILL STILL BE REQUIRED BY END USERS TO OPTIMIZE PCB MOUNTING PROCESSES AND BOARD DESIGN IN ORDER TO MEET INDIVIDUAL / SPECIFIC REQUIREMENTS.

| | | | |
|---------------------------------------------------------------------------------------------|---------------------------|----------------------------|--|
| © FREESCALE SEMICONDUCTOR, INC. ALL RIGHTS RESERVED. | MECHANICAL OUTLINE | PRINT VERSION NOT TO SCALE | |
| TITLE: POWER QUAD FLAT NON-LEADED PACKAGE (PWR QFN) 16 TERMINAL, 0.9 PITCH(12X12X2.1) | DOCUMENT NO: 98ARL10521D | REV: D | |
| | CASE NUMBER: 1402-03 | 21 SEP 2011 | |
| | STANDARD: NON-JEDEC | | |



NOTES:

1. ALL DIMENSIONS ARE IN MILLIMETERS.
2. DIMENSIONING AND TOLERANCING PER ASME Y14.5M-1994.
3. THE COMPLETE JEDEC DESIGNATOR FOR THIS PACKAGE IS: HF-PQFP-N.
4.  COPLANARITY APPLIES TO LEADS AND CORNER LEADS.
5. MINIMUM METAL GAP SHOULD BE 0.25MM.

| | | | |
|---------------------------------------------------------------------------------------------|---------------------------|----------------------------|--|
| © FREESCALE SEMICONDUCTOR, INC. ALL RIGHTS RESERVED. | MECHANICAL OUTLINE | PRINT VERSION NOT TO SCALE | |
| TITLE: POWER QUAD FLAT NON-LEADED PACKAGE (PWR QFN) 16 TERMINAL, 0.9 PITCH(12X12X2.1) | DOCUMENT NO: 98ARL10521D | REV: D | |
| | CASE NUMBER: 1402-03 | 21 SEP 2011 | |
| | STANDARD: NON-JEDEC | | |

Figure 15.

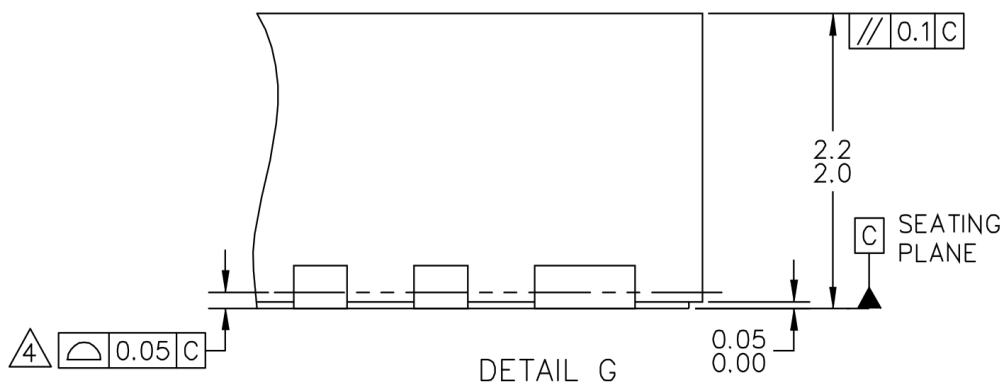
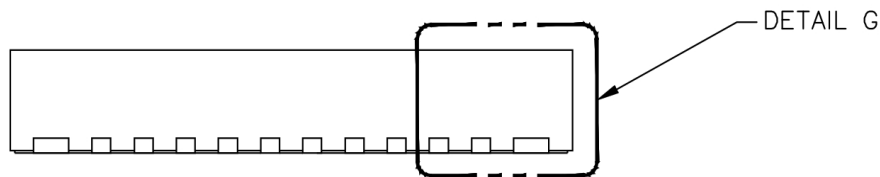
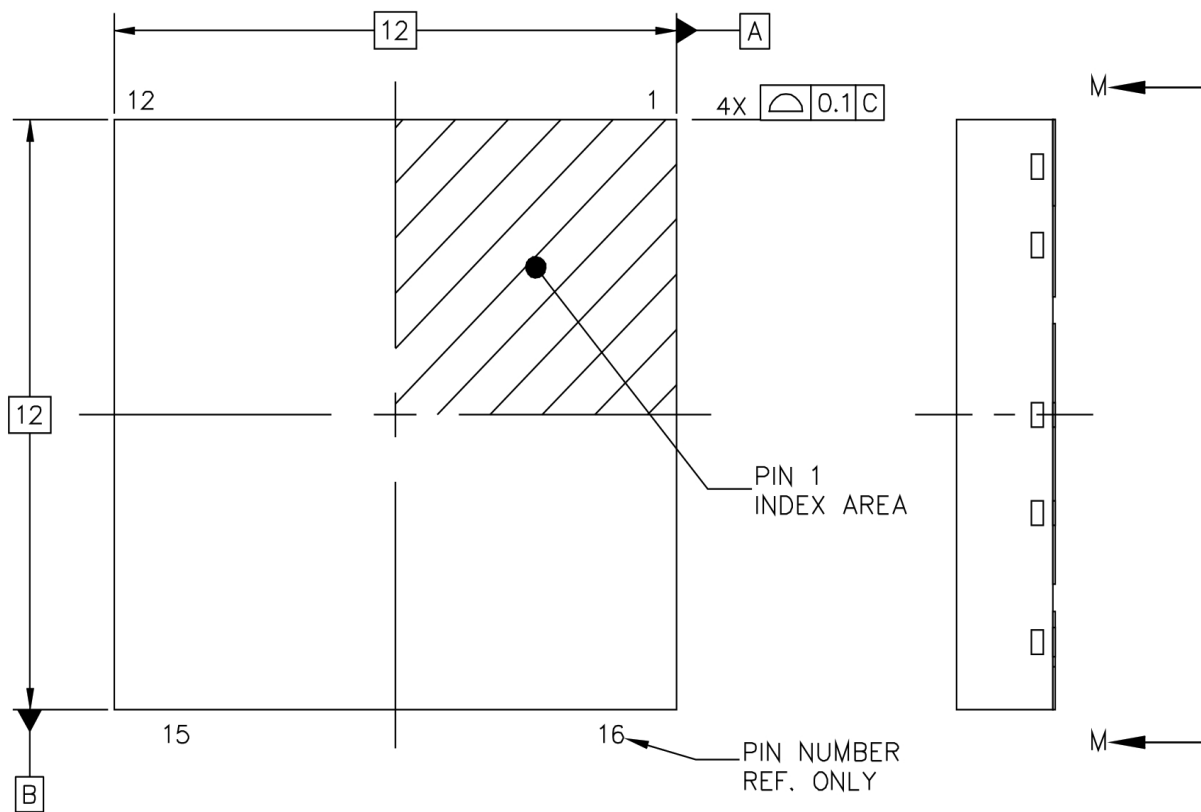

| | | |
|--------------------------------------------------------------|--------------------------|----------------------------|
| © NXP SEMICONDUCTORS N.V. ALL RIGHTS RESERVED | MECHANICAL OUTLINE | PRINT VERSION NOT TO SCALE |
| TITLE: PQFN, 12 X 12 X 2.1 PKG, 0.9 PITCH, 16 TERMINAL | DOCUMENT NO: 98ASA00815D | REV: B |
| | STANDARD: NON-JEDEC | |
| | SOT1630-2 | 22 MAY 2018 |

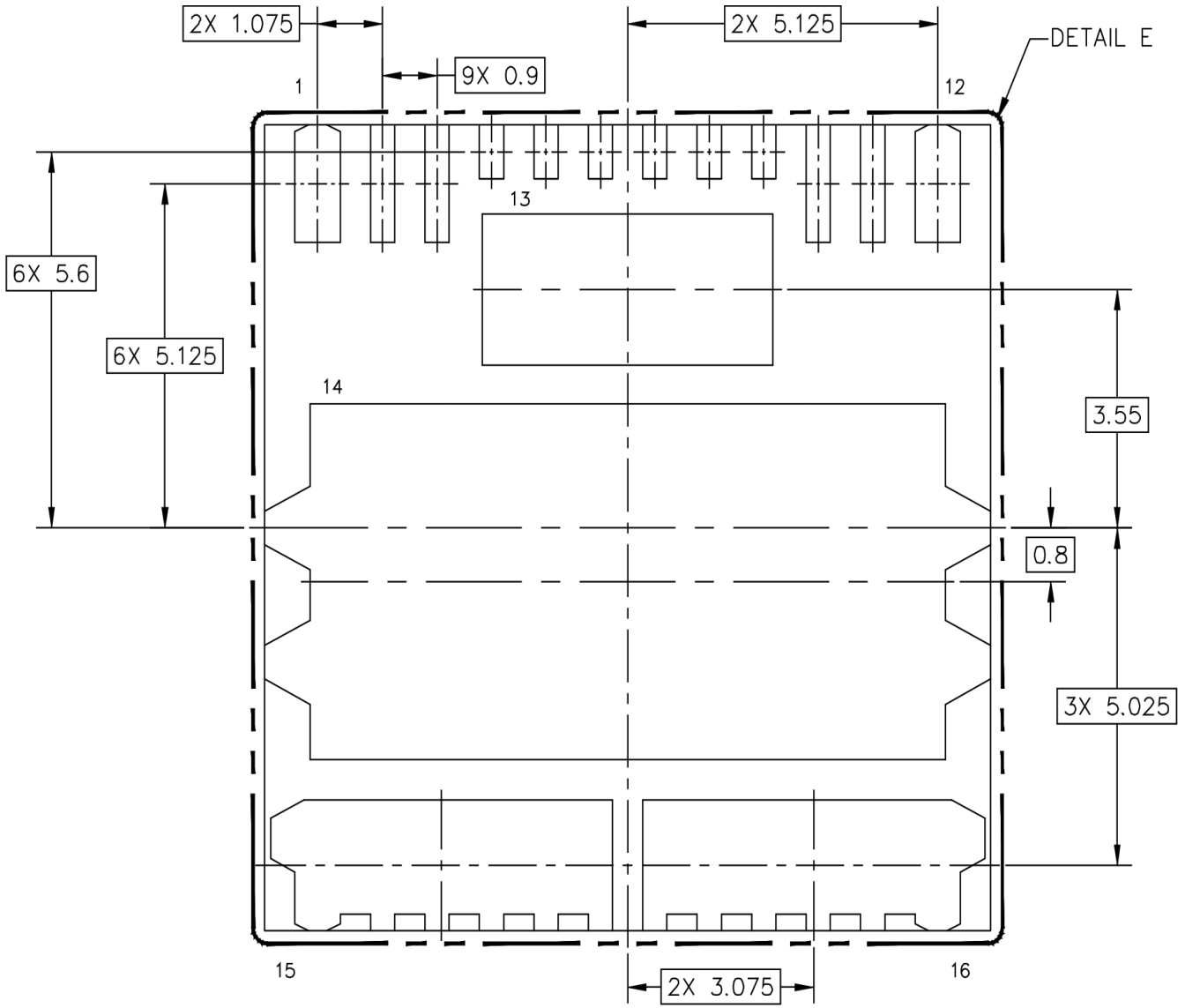

VIEW M-M

| | | | |
|--------------------------------------------------------------|--------------------|----------------------------|-------------|
| © NXP SEMICONDUCTORS N.V. ALL RIGHTS RESERVED | MECHANICAL OUTLINE | PRINT VERSION NOT TO SCALE | |
| TITLE: PQFN, 12 X 12 X 2.1 PKG, 0.9 PITCH, 16 TERMINAL | | DOCUMENT NO: 98ASA00815D | REV: B |
| | | STANDARD: NON-JEDEC | |
| | | SOT1630-2 | 22 MAY 2018 |

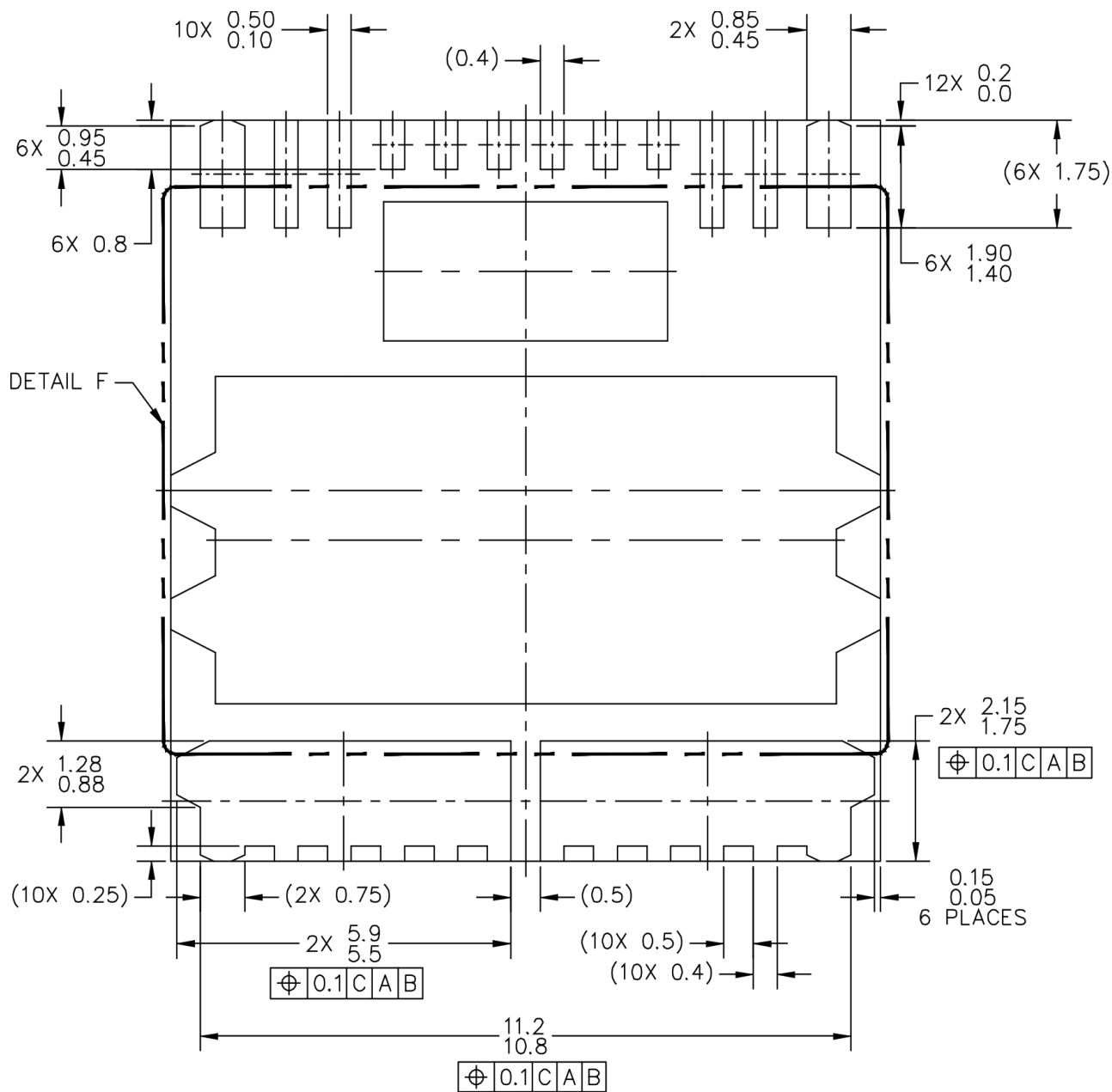

UNLESS OTHERWISE SPECIFIED
POSITIONAL TOLERANCE FOR
ALL LEADS SHALL BE AS FOLLOWS

| | | | | | |
|---|------|---|---|---|---|
| Φ | 0.1 | M | C | A | B |
| | 0.05 | M | C | | |

DETAIL E

| | | |
|--------------------------------------------------------------|--------------------------|----------------------------|
| © NXP SEMICONDUCTORS N.V. ALL RIGHTS RESERVED | MECHANICAL OUTLINE | PRINT VERSION NOT TO SCALE |
| TITLE: PQFN, 12 X 12 X 2.1 PKG, 0.9 PITCH, 16 TERMINAL | DOCUMENT NO: 98ASA00815D | REV: B |
| | STANDARD: NON-JEDEC | |
| | SOT1630-2 | 22 MAY 2018 |

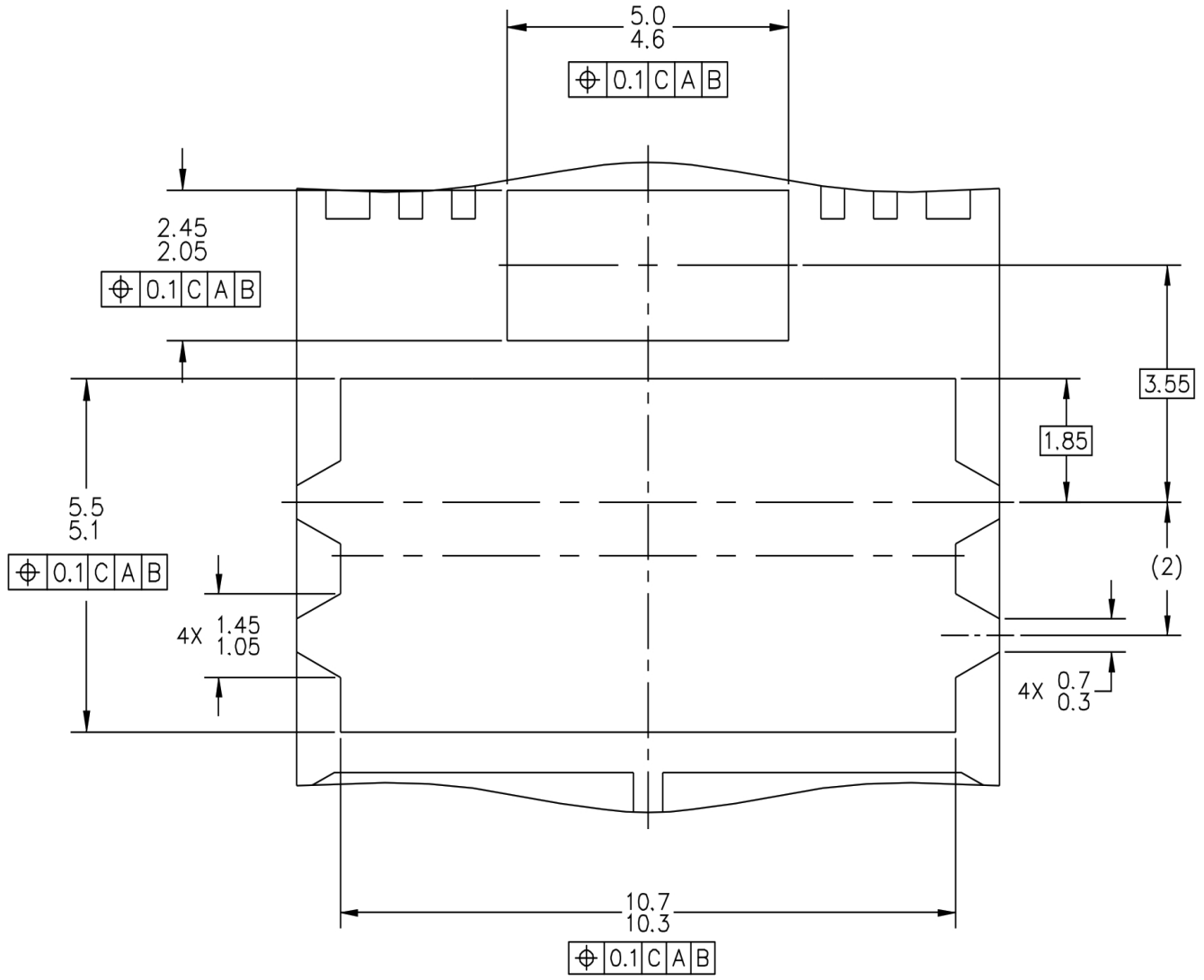

DETAIL F

| | | | |
|--------------------------------------------------------------|--------------------|----------------------------|-------------|
| © NXP SEMICONDUCTORS N.V. ALL RIGHTS RESERVED | MECHANICAL OUTLINE | PRINT VERSION NOT TO SCALE | |
| TITLE: PQFN, 12 X 12 X 2.1 PKG, 0.9 PITCH, 16 TERMINAL | | DOCUMENT NO: 98ASA00815D | REV: B |
| | | STANDARD: NON-JEDEC | |
| | | SOT1630-2 | 22 MAY 2018 |

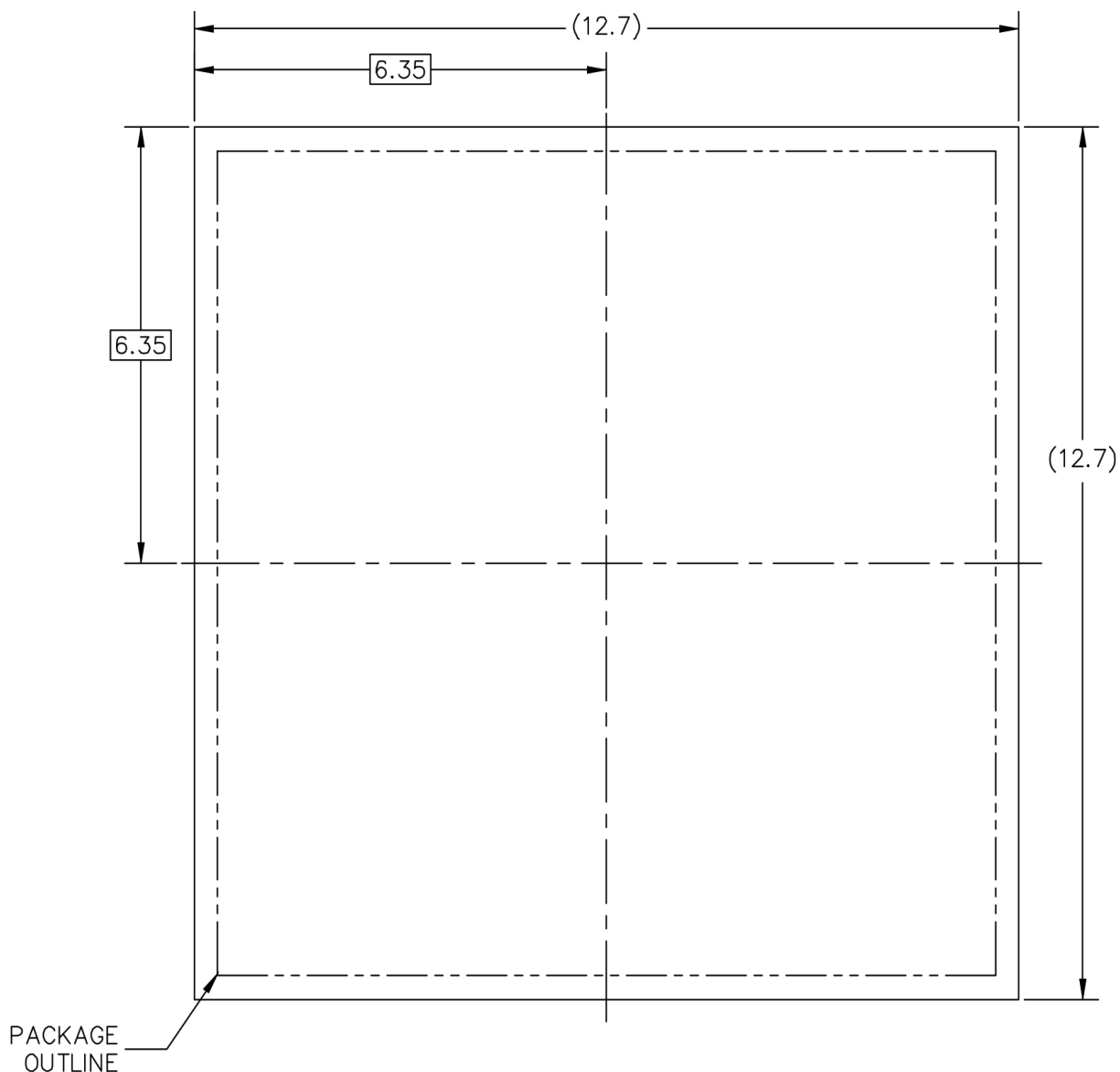

PCB DESIGN GUIDELINES – SOLDER MASK OPENING PATTERN 1

THIS SHEET SERVES ONLY AS A GUIDELINE TO HELP DEVELOP A USER SPECIFIC SOLUTION. DEVELOPMENT EFFORT WILL STILL BE REQUIRED BY END USERS TO OPTIMIZE PCB MOUNTING PROCESSES AND BOARD DESIGN IN ORDER TO MEET INDIVIDUAL / SPECIFIC REQUIREMENTS.

| | | | |
|--------------------------------------------------------------|--------------------|----------------------------|-------------|
| © NXP SEMICONDUCTORS N.V. ALL RIGHTS RESERVED | MECHANICAL OUTLINE | PRINT VERSION NOT TO SCALE | |
| TITLE: PQFN, 12 X 12 X 2.1 PKG, 0.9 PITCH, 16 TERMINAL | | DOCUMENT NO: 98ASA00815D | REV: B |
| | | STANDARD: NON-JEDEC | |
| | | SOT1630-2 | 22 MAY 2018 |

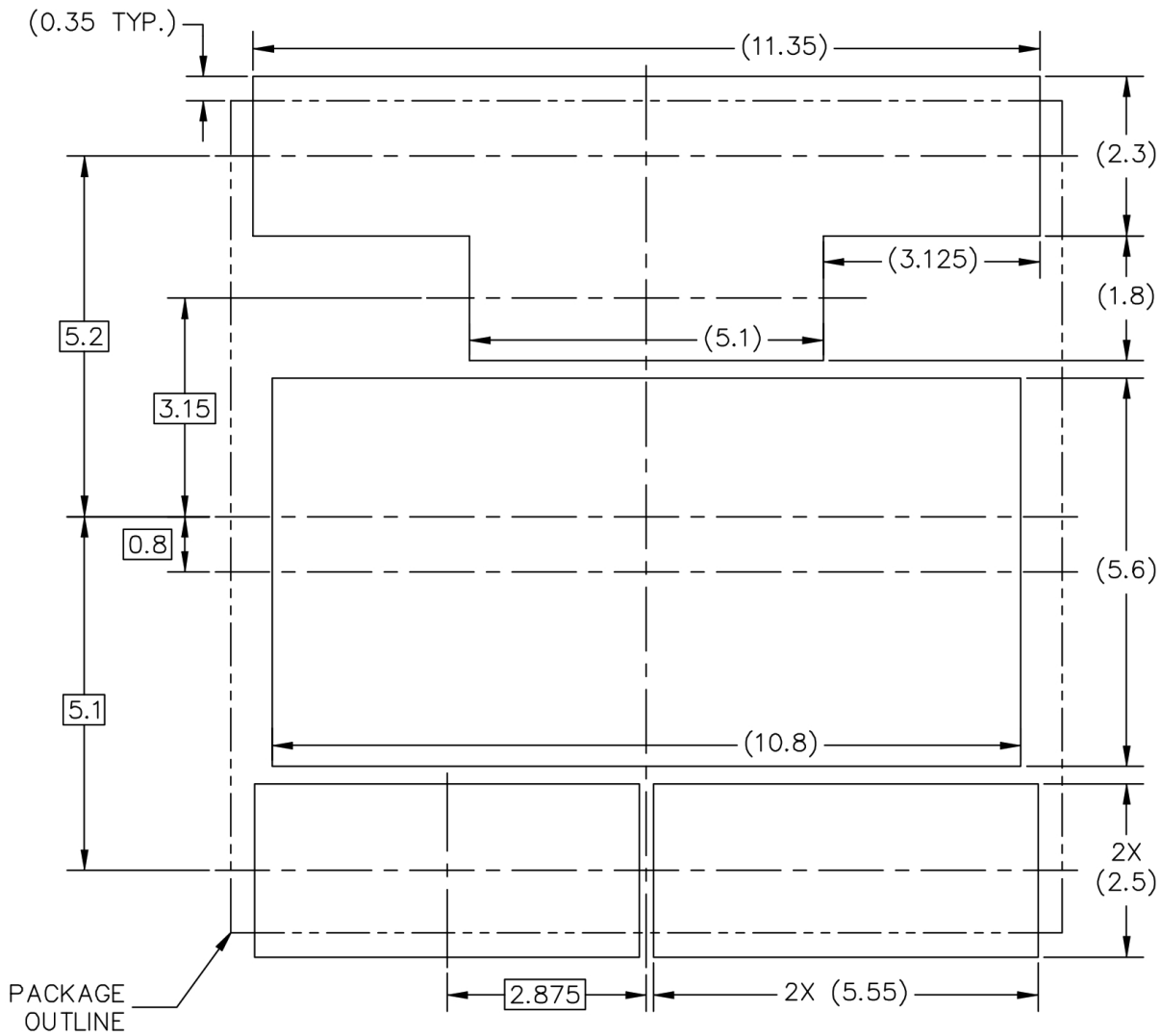

PCB DESIGN GUIDELINES – SOLDER MASK OPENING PATTERN 2

THIS SHEET SERVES ONLY AS A GUIDELINE TO HELP DEVELOP A USER SPECIFIC SOLUTION. DEVELOPMENT EFFORT WILL STILL BE REQUIRED BY END USERS TO OPTIMIZE PCB MOUNTING PROCESSES AND BOARD DESIGN IN ORDER TO MEET INDIVIDUAL / SPECIFIC REQUIREMENTS.

| | | | |
|--------------------------------------------------------------|--------------------|----------------------------|-------------|
| © NXP SEMICONDUCTORS N.V. ALL RIGHTS RESERVED | MECHANICAL OUTLINE | PRINT VERSION NOT TO SCALE | |
| TITLE: PQFN, 12 X 12 X 2.1 PKG, 0.9 PITCH, 16 TERMINAL | | DOCUMENT NO: 98ASA00815D | REV: B |
| | | STANDARD: NON-JEDEC | |
| | | SOT1630-2 | 22 MAY 2018 |

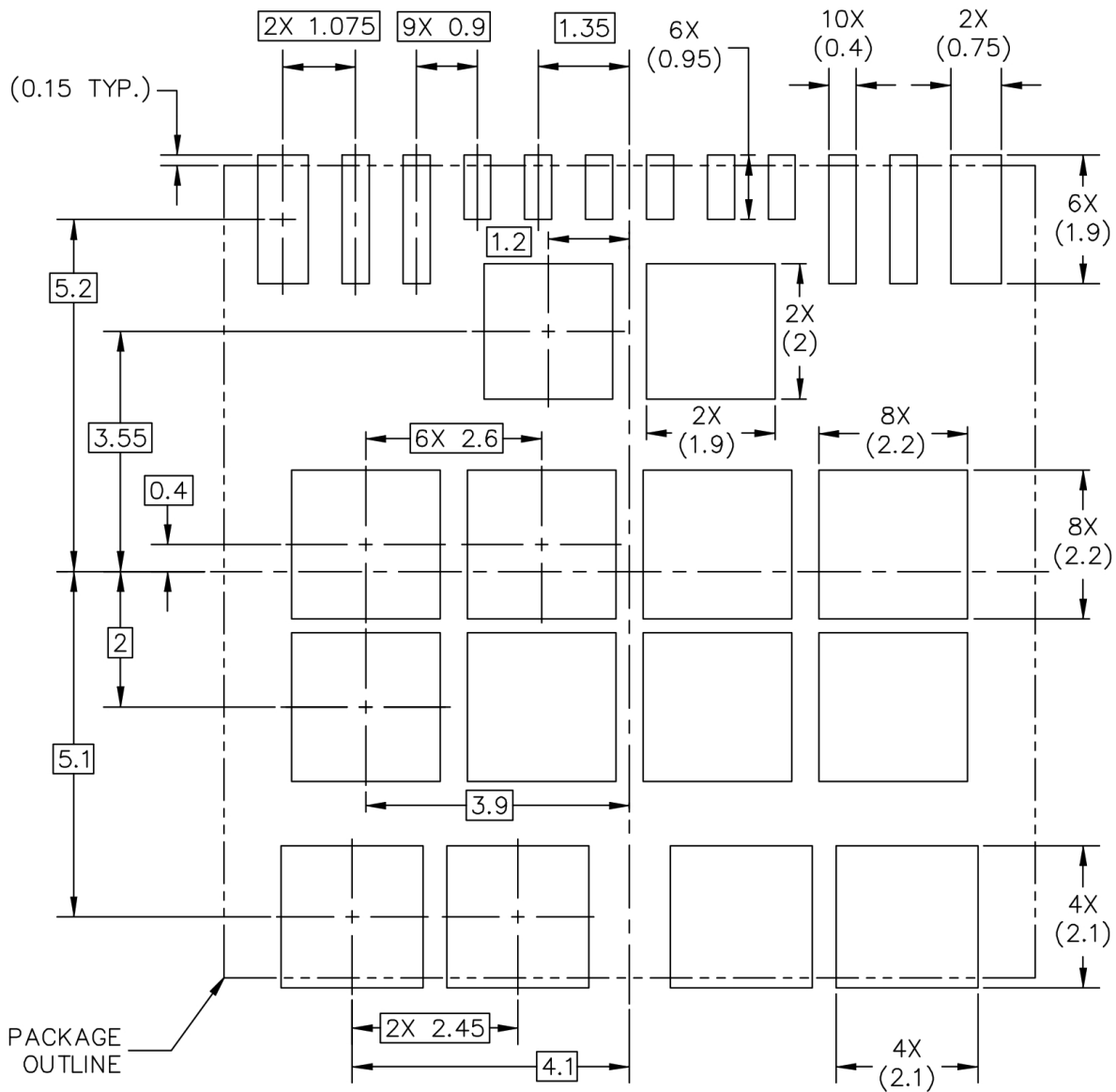

SOLDER PASTE STENCIL GUIDELINES

THIS SHEET SERVES ONLY AS A GUIDELINE TO HELP DEVELOP A USER SPECIFIC SOLUTION. DEVELOPMENT EFFORT WILL STILL BE REQUIRED BY END USERS TO OPTIMIZE PCB MOUNTING PROCESSES AND BOARD DESIGN IN ORDER TO MEET INDIVIDUAL / SPECIFIC REQUIREMENTS.

| | | | |
|--------------------------------------------------------------|--------------------|----------------------------|-------------|
| © NXP SEMICONDUCTORS N.V. ALL RIGHTS RESERVED | MECHANICAL OUTLINE | PRINT VERSION NOT TO SCALE | |
| TITLE: PQFN, 12 X 12 X 2.1 PKG, 0.9 PITCH, 16 TERMINAL | | DOCUMENT NO: 98ASA00815D | REV: B |
| | | STANDARD: NON-JEDEC | |
| | | SOT1630-2 | 22 MAY 2018 |

NOTES:

1. ALL DIMENSIONS ARE IN MILLIMETERS.
2. DIMENSIONING AND TOLERANCING PER ASME Y14.5M-1994.
3. THIS IS NON-JEDEC REGISTERED PACKAGE.

△ 4. COPLANARITY APPLIES TO LEADS AND CORNER LEADS.

5. MINIMUM METAL GAP IS GUARANTEED TO BE 0.25 MM.

| | | |
|--------------------------------------------------------------|--------------------------|----------------------------|
| © NXP SEMICONDUCTORS N.V. ALL RIGHTS RESERVED | MECHANICAL OUTLINE | PRINT VERSION NOT TO SCALE |
| TITLE: PQFN, 12 X 12 X 2.1 PKG, 0.9 PITCH, 16 TERMINAL | DOCUMENT NO: 98ASA00815D | REV: B |
| | STANDARD: NON-JEDEC | |
| | SOT1630-2 | 22 MAY 2018 |

Additional documentation

Thermal Addendum (rev 3.0)

Introduction

This thermal addendum is provided as a supplement to the 33984 technical datasheet. The addendum provides thermal performance information which may be critical in the design and development of system applications. All electrical, application, and packaging information is provided in the datasheet.

Packaging and Thermal Considerations

This package is a dual die package. There are two heat sources in the package independently heating with P_1 and P_2 . This results in two junction temperatures, T_{J1} and T_{J2} , and a thermal resistance matrix with $R_{\theta JA mn}$.

For $m, n = 1$, $R_{\theta JA 11}$ is the thermal resistance from Junction 1 to the reference temperature while only heat source 1 is heating with P_1 .

For $m = 1, n = 2$, $R_{\theta JA 12}$ is the thermal resistance from Junction 1 to the reference temperature while heat source 2 is heating with P_2 . This applies to $R_{\theta J21}$ and $R_{\theta J22}$, respectively.

$$\begin{Bmatrix} T_{J1} \\ T_{J2} \end{Bmatrix} = \begin{bmatrix} R_{\theta JA 11} & R_{\theta JA 12} \\ R_{\theta JA 21} & R_{\theta JA 22} \end{bmatrix} \cdot \begin{Bmatrix} P_1 \\ P_2 \end{Bmatrix}$$

The stated values are solely for a thermal performance comparison of one package to another in a standardized environment. This methodology is not meant to and does not predict the performance of a package in an application-specific environment. Stated values were obtained by measurement and simulation according to the standards listed below.

Standards

Table 21. Thermal performance comparison

| Thermal Resistance | 1 = Power Chip, 2 = Logic Chip [°C/W] | | |
|---------------------------------------|---------------------------------------|----------------------------------|----------------|
| | $m = 1, n = 1$ | $m = 1, n = 2$ $m = 2, n = 1$ | $m = 2, n = 2$ |
| $R_{\theta JA mn}$ ^{(1) (2)} | 20 | 16 | 39 |
| $R_{\theta JB mn}$ ^{(2) (3)} | 6.0 | 2.0 | 26 |
| $R_{\theta JA mn}$ ^{(1) (4)} | 53 | 40 | 72 |
| $R_{\theta JC mn}$ ⁽⁵⁾ | <0.5 | 0.0 | 1.0 |

Notes:

1. Per JEDEC JESD51-2 at natural convection, still air condition.
2. 2s2p thermal test board per JEDEC JESD51-7 and JESD51-5.
3. Per JEDEC JESD51-8, with the board temperature on the center trace near the power outputs.
4. Single layer thermal test board per JEDEC JESD51-3 and JESD51-5.
5. Thermal resistance between the die junction and the exposed pad; "infinite" heat sink attached to exposed pad.

33984

HIGH-SIDE SWITCH

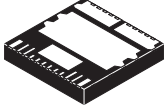

98ARL10521D
98ASA00815D
16-PIN PQFN
12 mm x 12 mm

Note For package dimensions, refer to 98ARL10521D and 98ASA00815D.

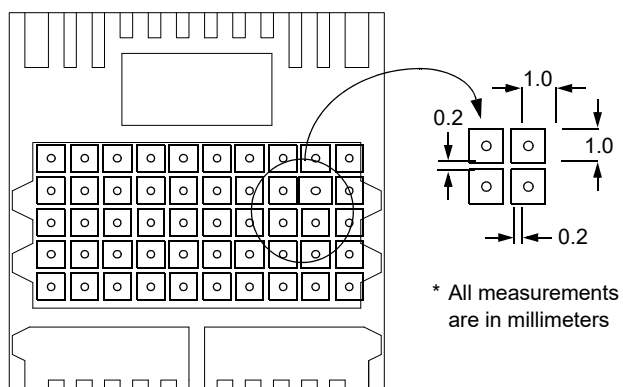

Note: Recommended via diameter is 0.5 mm. PTH (plated through hole) via must be plugged / filled with epoxy or solder mask in order to minimize void formation and to avoid any solder wicking into the via.

Figure 16. Surface mount for power PQFN with exposed pads

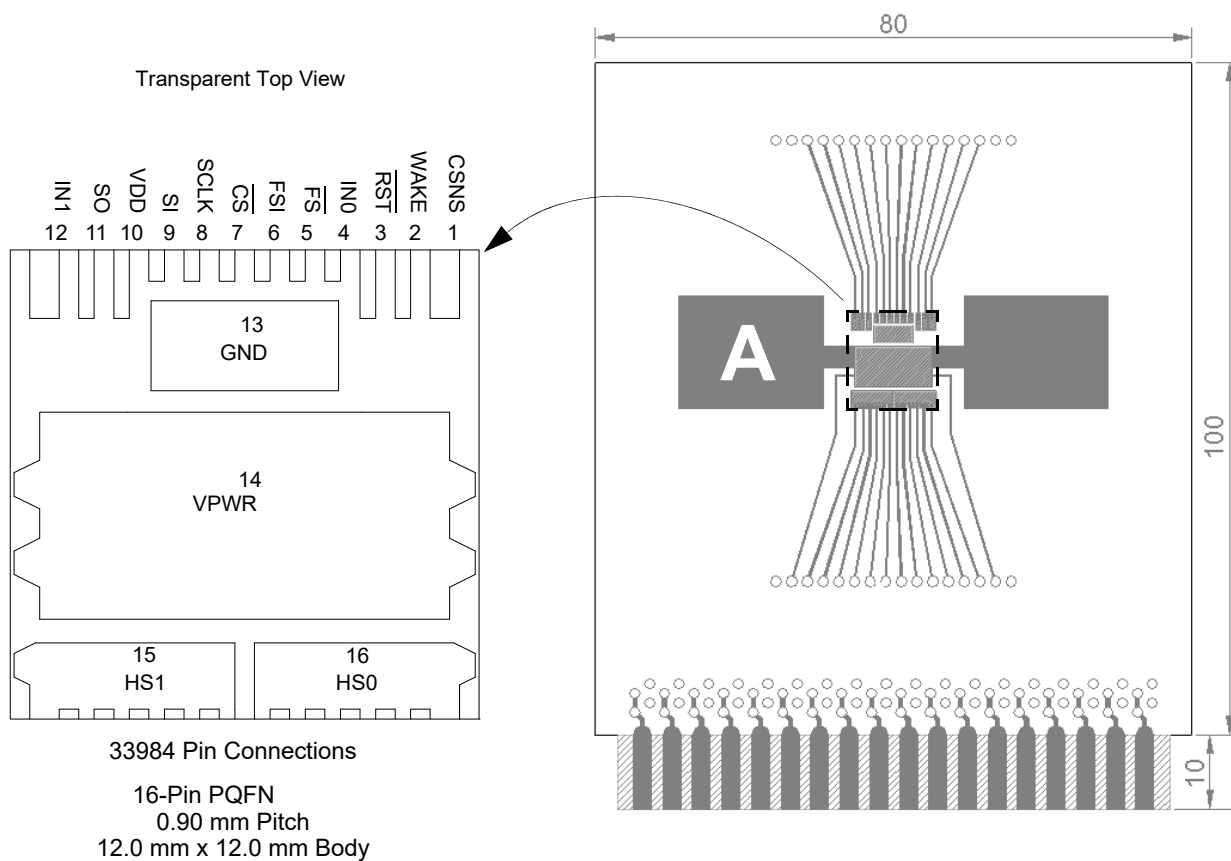

Figure 17. Thermal test board

Table 22. Device on thermal test board

Material: Single layer printed circuit board
 FR4, 1.6 mm thickness
 Cu traces, 0.07 mm thickness

Outline: 80 mm x 100 mm board area, including edge connector
 for thermal testing

Area A: Cu heat-spreading areas on board surface

Ambient Conditions: Natural convection, still air

Table 23. Thermal resistance performance

| Thermal Resistance | Area A (mm ²) | 1 = Power Chip, 2 = Logic Chip (°C/W) | | |
|--------------------|---------------------------|---------------------------------------|----------------------------------------------------------|----------------------------|
| | | <i>m</i> = 1, <i>n</i> = 1 | <i>m</i> = 1, <i>n</i> = 2 <i>m</i> = 2, <i>n</i> = 1 | <i>m</i> = 2, <i>n</i> = 2 |
| $R_{\theta JA mn}$ | 0 | 55 | 42 | 74 |
| | 300 | 41 | 31 | 66 |
| | 600 | 38 | 29 | 64 |

$R_{\theta JA}$ is the thermal resistance between die junction and ambient air. This device is a dual die package. Index *m* indicates the die which is heated. Index *n* refers to the number of the die where the junction temperature is sensed.

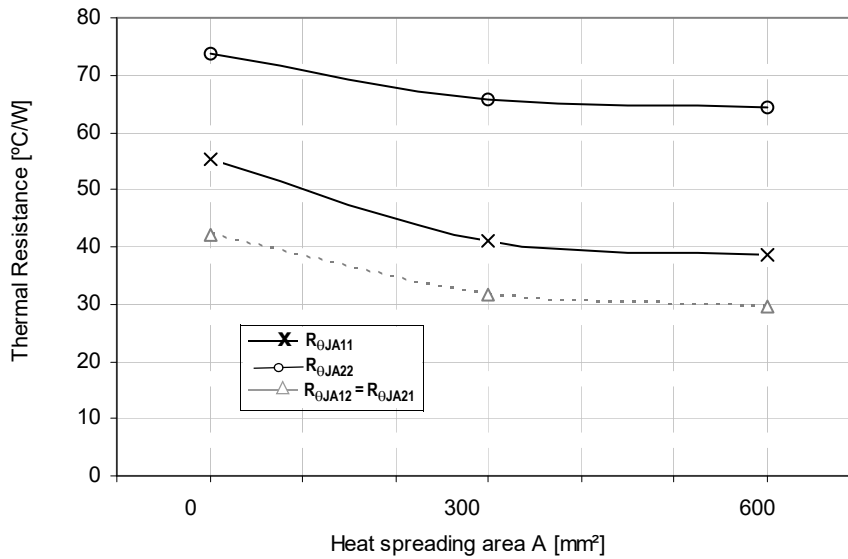

Figure 18. Device on thermal test board $R_{\theta JA}$

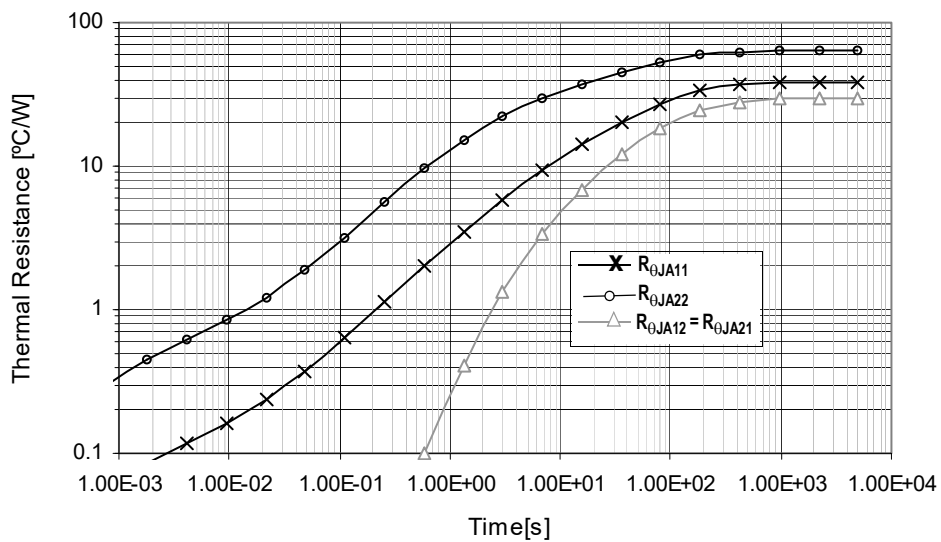

Figure 19. Transient thermal resistance $R_{\theta JA}$ (1.0 W step response) device on thermal test board area $A = 600(\text{mm}^2)$

Revision history

| Revision | Date | Description of Changes |
|----------|---------|--------------------------------------------------------------------------------------------------------------------------------------------------------------------------------------------------------------------------------------------------------------------------------------------------------------------------------------------------------------------------------------------------------------------------------------------------------------------------------------------------------------------------------------------------------------------------------------------------------------------------------------------------------------------------------------------------------------------------------------------------------------------------------------------------------------------------------------------------------------------------------------------------------------------------------------------------------------------------------------------------------------------------------------------------------------------------------------------------------------------------------------|
| 6.0 | 2/2006 | <ul style="list-style-type: none"> Implemented Revision History page Deletion of MC33984 part number, replaced with MC33984B. |
| 7.0 | 5/2006 | <ul style="list-style-type: none"> Corrected Pin connections to the proper case outline Added final sentence to Open Load Fault (Non-Latching) Corrected heading labels on Input timing switching characteristics Changed labels in the Typical applications drawing Corrected Package dimensions to Revision C Added Thermal Addendum (rev 3.0). |
| 8.0 | 1/2007 | <ul style="list-style-type: none"> Added RoHS logo |
| 9.0 | 1/2007 | <ul style="list-style-type: none"> Changed several names on the Typical applications on page 32 Added section Output current monitoring on page 33 |
| 10.0 | 8/2007 | <ul style="list-style-type: none"> Updated Freescale format and style Updated Thermal Rating ($R_{\theta JA}$) Junction-to-Ambient (from 20 to 30°C/W) Changes label for HS1 Switching Delay Time (OSD[2:0]) and HS0 Switching Delay Time (OSD[2:0]) Added Functional internal block description Updated Device behavior in case of undervoltage |
| 11.0 | 10/2009 | <ul style="list-style-type: none"> Added MC33984C to the ordering information Added a Device Variation table |
| 12.0 | 4/2010 | <ul style="list-style-type: none"> Corrected link from Device Variation Table to Table 3. No technical changes. |
| 13.0 | 6/2010 | <ul style="list-style-type: none"> Corrected typo in Tables 16 and 17 (Faults to Fault) and added "FAULT report of any fault on HS0 or HS1" to Table 17. |
| 14.0 | 5/2012 | <ul style="list-style-type: none"> Removed MC33984BPNA Updated orderable part number from MC33984CPNA to MC33984CHFK Updated ⁽⁶⁾ Updated Soldering information Updated Freescale form and style |
| 15.0 | 8/2012 | <ul style="list-style-type: none"> Updated values in Table 14. Documented with PB15287. |
| 16.0 | 10/2012 | <ul style="list-style-type: none"> Made limit changes to Dynamic electrical characteristics min, typ, and max. |
| | 9/2014 | <ul style="list-style-type: none"> Corrected Orderable Part number information. Updated Freescale form and style Updated back page |
| | 10/2016 | <ul style="list-style-type: none"> Updated document to NXP form and style |
| 17.0 | 07/2023 | <ul style="list-style-type: none"> Updated under CIN 202306024I Updated copyright from 2016 to 2023 on Page 45. Added package outline drawing number 98ASA00815D to page 1. Added row for MC33984EHFK to Table 1. Added rows for MC33984EHFK/MC33984CHFK under Characteristic for I_{OCL0}. Parameters added for MC33984CHFK in Table 4. Added rows for MC33984EHFK/MC33984CHFK under Characteristic for C_{SR0} ... and associated parameters in Table 4. Added rows for MC33984EHFK/MC33984CHFK under Characteristic for SR_{RA_SLOW}, SR_{FA_SLOW}, SR_{FA_FAST}, $t_{DLY(ON)}$, $t_{DLY_SLOW(OFF)}$, $t_{DLY_FAST(OFF)}$, t_{OCL0} ..., and t_{WDT00} ... in Table 5. Updated text on page 35 to include "and 98ASA00815D", added Table 20. Added package outline drawing number 98ASA00815D and "and 98ASA00815D" to Note on page 53. Added figures for 98ASA00815D package dimensions. |

How to Reach Us:**Home Page:**[NXP.com](http://www.nxp.com)**Web Support:**<http://www.nxp.com/support>

Information in this document is provided solely to enable system and software implementers to use NXP products.

There are no expressed or implied copyright licenses granted hereunder to design or fabricate any integrated circuits based on the information in this document. NXP reserves the right to make changes without further notice to any products herein.

NXP makes no warranty, representation, or guarantee regarding the suitability of its products for any particular purpose, nor does NXP assume any liability arising out of the application or use of any product or circuit, and specifically disclaims any and all liability, including without limitation, consequential or incidental damages. "Typical" parameters that may be provided in NXP data sheets and/or specifications can and do vary in different applications, and actual performance may vary over time. All operating parameters, including "typicals," must be validated for each customer application by the customer's technical experts. NXP does not convey any license under its patent rights nor the rights of others. NXP sells products pursuant to standard terms and conditions of sale, which can be found at the following address:

<http://www.nxp.com/terms-of-use.html>.

NXP, the NXP logo, Freescale, the Freescale logo and SMARTMOS are trademarks of NXP B.V. All other product or service names are the property of their respective owners. All rights reserved.

© 2023 NXP B.V.

Document Number: MC33984
Rev. 17.0
07/2023



Looking for pricing, stock, or lifecycle information?

Click below to explore more details on WIN SOURCE:

 [View MC33984CHFQR2 on WIN SOURCE](#)

 [NXP / Nexperia Information](#)

Optimize Your Supply Chain with WIN SOURCE Solutions

-  Global Sourcing Solution
-  Obsolete Management
-  Cost Control Management
-  Shortage Management
-  Alternative Solution
-  Excess Inventory Management