



**THE DATASHEET OF
TC377TX96F300SABKXUMA1**



32-Bit

Microcontroller

TC37xEXT

32-Bit Single-Chip Microcontroller
AB-Step

32-Bit Single-Chip Microcontroller

Data Sheet

V 1.0, 2019-10

Microcontroller

Edition 2019-10

**Published by
Infineon Technologies AG
81726 Munich, Germany**

**© 2019 Infineon Technologies AG
All Rights Reserved.**

Legal Disclaimer

The information given in this document shall in no event be regarded as a guarantee of conditions or characteristics. With respect to any examples or hints given herein, any typical values stated herein and/or any information regarding the application of the device, Infineon Technologies hereby disclaims any and all warranties and liabilities of any kind, including without limitation, warranties of non-infringement of intellectual property rights of any third party.

Information

For further information on technology, delivery terms and conditions and prices, please contact the nearest Infineon Technologies Office (www.infineon.com)

Warnings

Due to technical requirements, components may contain dangerous substances. For information on the types in question, please contact the nearest Infineon Technologies Office.

Infineon Technologies components may be used in life-support devices or systems only with the express written approval of Infineon Technologies, if a failure of such components can reasonably be expected to cause the failure of that life-support device or system or to affect the safety or effectiveness of that device or system. Life support devices or systems are intended to be implanted in the human body or to support and/or maintain and sustain and/or protect human life. If they fail, it is reasonable to assume that the health of the user or other persons may be endangered.

Revision History

Page or Item	Subjects (major changes since previous revision)
V 0.6, 2018-10	
	The history is documented in the last chapter
V 0.6.1, 2019-01	
	The history is documented in the last chapter
V 0.7, 2019-05	
	The history is documented in the last chapter
V 1.0, 2019-10	
	The history is documented in the last chapter

Trademarks of Infineon Technologies AG

AURIX™, C166™, CanPAK™, CIPOS™, CIPURSE™, EconoPACK™, CoolMOS™, CoolSET™, CORECONTROL™, CROSSAVE™, DAVE™, DI-POL™, EasyPIM™, EconoBRIDGE™, EconoDUAL™, EconoPIM™, EconoPACK™, EiceDRIVER™, eupec™, FCOS™, HITFET™, HybridPACK™, I²RF™, ISOFACE™, IsoPACK™, MIPAQ™, ModSTACK™, my-d™, NovalithIC™, OptiMOS™, ORIGA™, POWERCODE™; PRIMARION™, PrimePACK™, PrimeSTACK™, PRO-SIL™, PROFET™, RASIC™, ReverSave™, SatRIC™, SIEGET™, SINDRION™, SIPMOS™, SmartLEWIS™, SOLID FLASH™, TEMPFET™, thinQ!™, TRENCHSTOP™, TriCore™.

Other Trademarks

Advance Design System™ (ADS) of Agilent Technologies, AMBA™, ARM™, MULTI-ICE™, KEIL™, PRIMECELL™, REALVIEW™, THUMB™, μ Vision™ of ARM Limited, UK. AUTOSAR™ is licensed by AUTOSAR development partnership. Bluetooth™ of Bluetooth SIG Inc. CAT-iq™ of DECT Forum. COLOSSUS™, FirstGPS™ of Trimble Navigation Ltd. EMV™ of EMVCo, LLC (Visa Holdings Inc.). EPCOS™ of Epcos AG. FLEXGO™ of Microsoft Corporation. FlexRay™ is licensed by FlexRay Consortium. HYPERTERMINAL™ of Hilgraeve Incorporated. IEC™ of Commission Electrotechnique Internationale. IrDA™ of Infrared Data Association Corporation. ISO™ of INTERNATIONAL ORGANIZATION FOR STANDARDIZATION. MATLAB™ of MathWorks, Inc. MAXIM™ of Maxim Integrated Products, Inc. MICROTEC™, NUCLEUS™ of Mentor Graphics Corporation. MIPI™ of MIPI Alliance, Inc. MIPS™ of MIPS Technologies, Inc., USA. muRata™ of MURATA MANUFACTURING CO., MICROWAVE OFFICE™ (MWO) of Applied Wave Research Inc., OmniVision™ of OmniVision Technologies, Inc. Openwave™ Openwave Systems Inc. RED HAT™ Red Hat, Inc. RFMD™ RF Micro Devices, Inc. SIRIUS™ of Sirius Satellite Radio Inc. SOLARIS™ of Sun Microsystems, Inc. SPANSION™ of Spansion LLC Ltd. Symbian™ of Symbian Software Limited. TAIYO YUDEN™ of Taiyo Yuden Co. TEAKLITE™ of CEVA, Inc. TEKTRONIX™ of Tektronix Inc. TOKO™ of TOKO KABUSHIKI KAISHA TA. UNIX™ of X/Open Company Limited. VERILOG™, PALLADIUM™ of Cadence Design Systems, Inc. VLYNQ™ of Texas Instruments Incorporated. VXWORKS™, WIND RIVER™ of WIND RIVER SYSTEMS, INC. ZETEX™ of Diodes Zetex Limited.

Last Trademarks Update 2011-11-11

Table of Contents

1	Summary of Features	7
2	TC37xEXT Pin Definition and Functions	12
2.1	LFBGA-292 Package Pinning of TC37xEXT TE	13
2.2	LFBGA-292 Package Pinning of TC37xEXT TX	116
2.3	LQFP-176 Package Pinning of TC37xEXT	219
2.4	LQFP-144 Package Pinning of TC37xEXT	301
2.5	Pad Position Configuration of TC37xEXT	368
2.6	Legend	386
3	Electrical Specification	388
3.1	Parameter Interpretation	388
3.2	Absolute Maximum Ratings	389
3.3	Pin Reliability in Overload	390
3.4	Operating Conditions	393
3.5	5 V / 3.3 V switchable Pads	397
3.6	High performance LVDS Pads	417
3.7	VADC Parameters	420
3.8	DSADC Parameters	424
3.9	MHz Oscillator	427
3.10	Back-up Clock	429
3.11	Temperature Sensor	430
3.12	Power Supply Current	431
3.12.1	Calculating the 1.25 V Current Consumption	437
3.13	Power Supply Infrastructure and Supply Start-up	438
3.13.1	Supply Ramp-up and Ramp-down Behavior	438
3.13.1.1	Single Supply mode (a)	438
3.13.1.2	Single Supply mode (e)	441
3.13.1.3	External Supply mode (d)	443
3.13.1.4	External Supply mode (h)	445
3.14	Reset Timing	447
3.15	PMS	450
3.16	System Phase Locked Loop (SYS_PLL)	460
3.17	Peripheral Phase Locked Loop (PER_PLL)	461
3.18	AC Specifications	462
3.19	JTAG Parameters	463
3.20	DAP Parameters	465
3.21	ASCLIN SPI Master Timing	467
3.22	QSPI Timings, Master and Slave Mode	469
3.23	MSC Timing 5 V Operation	473
3.24	Ethernet Interface (ETH) Characteristics	475
3.24.1	ETH Measurement Reference Points	475
3.24.2	ETH Management Signal Parameters (ETH_MDC, ETH_MDIO)	476
3.24.3	ETH MII Parameters	477
3.24.4	ETH RMII Parameters	478
3.24.5	ETH RGMII Parameters	479
3.25	E-Ray Parameters	480
3.26	HSCT Parameters	482
3.27	Inter-IC (I2C) Interface Timing	483
3.28	SDMMC Interface Timing	487

3.29	Camera Interface Timing (CIF)	488
3.30	Flash Target Parameters	489
3.31	Quality Declarations	494
3.32	Package Outline	495
3.32.1	Package Parameters	496
4	History	498
4.1	Changes from Version 0.4 to Version 0.6	498
4.2	Changes from Version 0.6 to Version 0.61	507
4.3	Changes from Version 0.61 to Version 0.7	510
4.4	Changes from Version 0.7 to Version 1.0	512

1 Summary of Features

The TC37xEXT product family has the following features:

- High Performance Microcontroller with three CPU cores
- Three 32-bit super-scalar TriCore CPUs (TC1.6.2P), each having the following features:
 - Superior real-time performance
 - Strong bit handling
 - Fully integrated DSP capabilities
 - Multiply-accumulate unit able to sustain 2 MAC operations per cycle
 - Fully pipelined Floating point unit (FPU)
 - up to 300 MHz operation at full temperature range
 - up to 240/96 Kbyte Data Scratch-Pad RAM (DSPR)
 - up to 64 Kbyte Instruction Scratch-Pad RAM (PSPR)
 - 32 Kbyte Instruction Cache (ICACHE)
 - 16 Kbyte Data Cache (DCACHE)
- Lockstepped shadow cores for up to three TC1.6.2P
- Multiple on-chip memories
 - All embedded NVM and SRAM are ECC protected
 - up to 6 Mbyte Program Flash Memory (PFLASH)
 - up to 384 Kbyte Data Flash Memory (DFLASH) usable for EEPROM emulation
 - BootROM (BROM)
- 128-Channel DMA Controller with safe data transfer
- Sophisticated interrupt system (ECC protected)
- High performance on-chip bus structure
 - 64-bit Cross Bar Interconnect (SRI) giving fast parallel access between bus masters, CPUs and memories
 - 32-bit System Peripheral Bus (SPB) for on-chip peripheral and functional units
 - SRI to SPB bus bridges (SFI Bridge)
- Optional Hardware Security Module (HSM) on some variants
- Safety Management Unit (SMU) handling safety monitor alarms
- Memory Test Unit with ECC, Memory Initialization and MBIST functions (MTU)
- Hardware I/O Monitor (IOM) for checking of digital I/O
- Versatile On-chip Peripheral Units
 - 12 Asynchronous/Synchronous Serial Channels (ASCLIN) with hardware LIN support (V1.3, V2.0, V2.1 and J2602) up to 50 MBaud
 - 5 Queued SPI Interface Channels (QSPI) with master and slave capability up to 50 Mbit/s
 - 1 High Speed Serial Link (HSSL) for serial inter-processor communication up to 320 Mbit/s
 - 2 serial Micro Second Bus interfaces (MSC) for serial port expansion to external power devices
 - 3 MCMCAN Modules with 4 CAN nodes for high efficiency data handling via FIFO buffering
 - 15 Single Edge Nibble Transmission (SENT) channels for connection to sensors
 - 1 FlexRay™ module with 2 channels (E-Ray) supporting V2.1
 - One Generic Timer Module (GTM) providing a powerful set of digital signal filtering and timer functionality to realize autonomous and complex Input/Output management
 - One Capture / Compare 6 module (Two kernels CCU60 and CCU61)

- One General Purpose 12 Timer Unit (GPT120)
- 2 channel Peripheral Sensor Interface conforming to V1.3 (PSI5)
- 1 Peripheral Sensor Interface with Serial PHY (PSI5-S)
- 1 Inter-Integrated Circuit Bus Interface (I2C) conforming to V2.1
- 2 IEEE802.3 Ethernet MAC with RMI and MII interfaces (ETH)
- Versatile Successive Approximation ADC (VADC)
 - Cluster of 12 independent ADC kernels
 - Input voltage range from 0 V to 5.5V (ADC supply)
- Delta-Sigma ADC (DSADC)
 - 6 channels
- Digital programmable I/O ports
- On-chip debug support for OCDS Level 1 (CPUs, DMA, On Chip Buses)
- multi-core debugging, real time tracing, and calibration
- four/five wire JTAG (IEEE 1149.1) or DAP (Device Access Port) interface
- Power Management System and on-chip regulators
- Clock Generation Unit with System PLL and Peripheral PLL
- Embedded Voltage Regulator

Ordering Information

The ordering code for Infineon microcontrollers provides an exact reference to the required product. This ordering code identifies:

- The derivative itself, i.e. its function set, the temperature range, and the supply voltage
- The package and the type of delivery

Table 1-1 Platform Feature Overview

Feature		TC37xEXT
CPUs	Type	TC1.6.2
	Cores / Checker Cores	3 / 3
	Max. Freq.	300 MHz
Cache per CPU	Program	32 KB
	Data	16 KB
SRAM per CPU	PSPR	64 KB
	DSPR	240 KB for CPU0,1/ 96 KB else
	DLMU	64 KB
SRAM global	DAM	32 KB
Extension Memory	TCM	2 MB
	XCM	1 MB
	XTM	16 KB
Program Flash	Size	6 MB
	Banks	2 x 3 MB
Data Flash	Size (single-ended)	256 KB + 128 KB
DMA	Channels	128
CONVCTRL	Modules	1
EVADC	Primary Groups/Channels	4 / 32
	Secondary Groups/Channels	4 / 64
	Fast Compare Channels	4
EDSADC	Channels	6

Table 1-1 Platform Feature Overview (cont'd)

Feature		TC37xEXT
GTM	Clusters	5 @ 200 MHz, 1 @ 100 MHz
	TIM (8 ch)	6
	TOM (16 ch)	3
	ATOM (8 ch)	6
	MCS (8 ch)	5
	CMU / ICM	1 / 1
	PSM	1
	TBU channels ¹⁾	4 (TBU0-3)
	SPE	2
	CMP / MON	1 / 1
	BRC / DPLL	1 / 1
	CDTM modules	5
	DTM modules	16 (6 on TOM, 10 on ATOM)
Timer	GPT12	1
	CCU6	1
STM	Modules	3
FlexRay	Modules	1
	Channels	2
CAN	Modules	3
	Nodes	3 x 4
	of which support TT-CAN	1
QSPI	Modules	5
	HSCI Channels	0
ASCLIN	Modules	12
I2C	Interfaces	1
SENT	Channels	15
PSI5	Modules	2
PSI5-S	Modules	1
HSSL	Channels	1
MSC	Channels	2
SDMMC	eMMC/SD Interface	1
CIF	Camera Interface	1
Ethernet (10/100Mbit/1Gbit)	Modules	2
FCE	Modules	1
Safety Support	SMU	yes
	IOM	yes
Security	HSM+	1

Table 1-1 Platform Feature Overview (cont'd)

Feature		TC37xEXT
Debug	OCDS	yes
	MCDS	yes
	miniMCDS	-
	miniMCDS TRAM	-
	AGBT	yes
Low Power Features	Standby RAM	2
	SCR	yes
Packages	Type	Pad Position Configuration / LFBGA-292 / LQFP-176 / LFQP-144
I/O	Type	5 V CMOS / 3.3 V CMOS / LVDS
T _{ambient}	Range	-40 ... +150°C

1) TBU3 has special purpose as angle clock.

2 TC37xEXT Pin Definition and Functions

The following figures show the TC37xEXT package variants:

- LFBGA-292 for feature package TE ([Figure 2-1](#))
- LFBGA-292 for feature package TX ([Figure 2-2](#))
- LQFP-176 for feature package ([Figure 2-3](#))
- LQFP-144 for feature package ([Figure 2-4](#))
- Pad Position Configuration of TC37xEXT ([Chapter 2.5](#))

TC37xEXT Pin Definition and Functions LFBGA-292 Package Pinning of

2.1 LFBGA-292 Package Pinning of TC37xEXT TE

	1	2	3	4	5	6	7	8	9	10	11	12	13	14	15	16	17	18	19	20				
A	NC1	VEXT	P10.7	P10.6	P10.2	P10.3	P10.0	P11.11	P11.9	P11.2	P13.3	P13.1	P14.8	P14.5	P14.1	P15.6	P15.4	P15.1	VDDP3	VSS	A			
B	P02.0	VSS	VEXT	P10.8	P10.5	P10.4	P10.1	P11.12	P11.10	P11.3	P13.2	P13.0	P14.6	P14.3	P14.4	P14.0	P15.3	VDDP3	VSS	P15.0	B			
C	P02.2	P02.1																	P15.2	P20.14	C			
D	P02.4	P02.3	VSS	VFLEX	P11.15	P11.14	P11.5	P11.6	P11.4	P14.10	P14.9	P14.7	P15.8	P15.7	VDD	VSS			P20.12	P20.13	D			
E	P02.6	P02.5	P02.9	VSS	P11.13	P11.8	P11.7	P11.1	P11.0	P12.1	P12.0	P14.2	P15.5	VDD	VSS	P20.9			P20.10	P20.11	E			
F	P02.8	P02.7	P02.11	P02.10											ESR0	P20.6			P20.7	P20.8	F			
G	P00.0	P00.1	P01.4	P01.3	VDDSB (VDD)				VSS	DAPE2	DAPE1	VSS	VDD					ESR1	PORST			P20.1	P20.3	G
H	P00.2	P00.3	P01.6	P01.5	VDDSB (VDD)	VSS		VSS	VSS	VSS	VDD						P21.7 / TDO	P21.6 / TDI			P20.2	P20.0	H	
J	P00.4	P00.5	P00.6	P01.7	VSS		VSS	VSS	VSS	VSS	VSS	VSS					TCK	P21.1			P21.3	P21.5	J	
K	P00.7	P00.9	P00.8	P00.10	AGBTC LKP (VSS)	VSS	VSS	VSS	VSS	VSS	VSS	VSS	DAPE0					TMS	P21.0			P21.2	P21.4	K
L	P00.11	P00.12	AN43	AN42	AGBTC LKN (VSS)	VSS	VSS	VSS	VSS	VSS	VSS	VSS	AGBTE RR (VSS)					P22.10	P22.11			TRST	VSS	L
M	AN46	AN47	AN41	AN40	VSS		VSS	VSS	VSS	VSS	VSS	VSS	VSS					P22.8	P22.9	XTAL2	XTAL1	M		
N	AN44	AN45	AN36 / P40.6	AN38 / P40.8	VDD		VSS	VSS	VSS	VSS	VSS	VSS	VDD					P22.6	P22.7	VDD	VEXT	N		
P	AN39 / P40.9	AN37 / P40.7	AN32 / P40.4	AN34	VDD		VSS	AGBTT XN (VSS)	AGBTT XP (VSS)	VSS	VDD					P22.4	P22.5			P22.1	P22.0	P		
R	AN33 / P40.5	AN35	AN31	AN23											P23.7	P23.6			P22.3	P22.2	R			
T	VAREF 2	VAGND 2	AN30	AN22	AN15	AN12	AN6	AN4	AN0	VEVRS B	P34.2	P34.4	P33.14	P32.5	VSS	P23.5			P23.3	P23.4	T			
U	AN29 / P40.14	AN28 / P40.13	NC1	AN17 / P40.10	AN14	AN9	AN7	AN3	AN1	P34.1	P34.3	P34.5	P33.15	P32.6	P32.7	VSS			P23.1	P23.2	U			
V	AN27 / P40.3	AN26 / P40.2																	VEXT	P23.0	V			
W	AN25 / P40.1	AN24 / P40.0	AN19 / P40.12	AN18 / P40.11	AN16	AN13	AN11	AN8	AN2	P33.0	P33.2	P33.4	P33.6	P33.8	P33.10	P33.12	P32.1 / VGATE 1P	P32.4	VSS	VEXT	W			
Y	NC1	AN21	AN20	VSSM	VDDM	VAREF 1	VAGND 1	AN10	AN5	P33.1	P33.3	P33.5	P33.7	P33.9	P33.11	P33.13	P32.0 / VGATE 1N	P32.2	P32.3	VSS	Y			

TC37xed - (top view)

Figure 2-1 TC37xEXT TE package variant LFBGA-292

TC37xEXT Pin Definition and Functions LFBGA-292 Package Pinning of

Table 2-1 Port 00 Functions

Ball	Symbol	Ctrl.	Buffer Type	Function
G1	P00.0	I	FAST / PU1 / VEXT / ES	General-purpose input
	GTM_TIM5_IN4_10			Mux input channel 4 of TIM module 5
	GTM_TIM3_IN0_1			Mux input channel 0 of TIM module 3
	GTM_TIM2_IN0_1			Mux input channel 0 of TIM module 2
	CCU61_CTRAPA			Trap input capture
	CCU60_T12HRE			External timer start 12
	MSC0_INJ0			Injection signal from port
	CIF_D9			sensor pixel data input
	GETH_MDIOA			MDIO Input
	P00.0			O0
	GTM_TOUT9	O1	GTM muxed output	
	IOM_REF0_9	O2	Reference input 0	
	ASCLIN3_ASCLK		Shift clock output	
	ASCLIN3_ATX		O3	Transmit output
	IOM_MON2_15	O3	Monitor input 2	
	IOM_REF2_15		Reference input 2	
	—	O4	Reserved	
	CAN10_TXD	O5	CAN transmit output node 0	
	—	O6	Reserved	
	CCU60_COUT63	O7	T13 PWM channel 63	
IOM_MON1_6	O7	Monitor input 1		
IOM_REF1_0		Reference input 1		
GETH_MDIO		O	MDIO Output	

TC37xEXT Pin Definition and Functions LFBGA-292 Package Pinning of

Table 2-1 Port 00 Functions (cont'd)

Ball	Symbol	Ctrl.	Buffer Type	Function
G2	P00.1	I	SLOW / PU1 / VEXT / ES	General-purpose input
	GTM_TIM5_IN5_11			Mux input channel 5 of TIM module 5
	GTM_TIM3_IN1_1			Mux input channel 1 of TIM module 3
	GTM_TIM2_IN1_1			Mux input channel 1 of TIM module 2
	CCU60_CC60INB			T12 capture input 60
	ASCLIN3_ARXE			Receive input
	EDSADC_DSCIN5A			Modulator clock input, channel 5
	CAN10_RXDA			CAN receive input node 0
	PSI5_RX0A			RXD inputs (receive data) channel 0
	CIF_D10			sensor pixel data input
	CCU61_CC60INA			T12 capture input 60
	SENT_SENT0B			Receive input channel 0
	EVADC_G9CH11			AI
	EDSADC_EDS5NA		Negative analog input channel 5, pin A	
	P00.1	O0	General-purpose output	
	GTM_TOUT10	O1	GTM muxed output	
	IOM_REF0_10		Reference input 0	
	ASCLIN3_ATX	O2	Transmit output	
	IOM_MON2_15		Monitor input 2	
	IOM_REF2_15		Reference input 2	
	—	O3	Reserved	
	EDSADC_DSCOUT5	O4	Modulator clock output	
	—	O5	Reserved	
	SENT_SPC0	O6	Transmit output	
	CCU61_CC60	O7	T12 PWM channel 60	
	IOM_MON1_8		Monitor input 1	
IOM_REF1_13		Reference input 1		

TC37xEXT Pin Definition and Functions LFBGA-292 Package Pinning of
Table 2-1 Port 00 Functions (cont'd)

Ball	Symbol	Ctrl.	Buffer Type	Function	
H1	P00.2	I	SLOW / PU1 / VEXT / ES1	General-purpose input	
	GTM_TIM5_IN6_11			Mux input channel 6 of TIM module 5	
	GTM_TIM3_IN1_2			Mux input channel 1 of TIM module 3	
	GTM_TIM2_IN1_2			Mux input channel 1 of TIM module 2	
	EDSADC_DSDIN5A			Digital datastream input, channel 5	
	SENT_SENT1B			Receive input channel 1	
	CIF_D11			sensor pixel data input	
	EVADC_G9CH10			AI	Analog input channel 10, group 9
	EDSADC_EDS5PA				Positive analog input channel 5, pin A
	P00.2			O0	General-purpose output
	GTM_TOUT11	O1	GTM muxed output		
	IOM_REF0_11		Reference input 0		
	ASCLIN3_ASCLK	O2	Shift clock output		
	CAN21_TXD	O3	CAN transmit output node 1		
	PSI5_TX0	O4	TXD outputs (send data)		
	IOM_MON1_14		Monitor input 1		
	IOM_REF1_14		Reference input 1		
	CAN03_TXD	O5	CAN transmit output node 3		
	IOM_MON2_8		Monitor input 2		
	IOM_REF2_8		Reference input 2		
	QSPI3_SLSO4	O6	Master slave select output		
	CCU61_COUT60	O7	T12 PWM channel 60		
	IOM_MON1_11		Monitor input 1		
	IOM_REF1_10		Reference input 1		

TC37xEXT Pin Definition and Functions LFBGA-292 Package Pinning of

Table 2-1 Port 00 Functions (cont'd)

Ball	Symbol	Ctrl.	Buffer Type	Function
H2	P00.3	I	SLOW / PU1 / VEXT / ES1	General-purpose input
	GTM_TIM5_IN7_10			Mux input channel 7 of TIM module 5
	GTM_TIM3_IN2_1			Mux input channel 2 of TIM module 3
	GTM_TIM2_IN2_1			Mux input channel 2 of TIM module 2
	CCU60_CC61INB			T12 capture input 61
	EDSADC_DSCIN3A			Modulator clock input, channel 3
	EDSADC_ITR5F			Trigger/Gate input, channel 5
	PSI5_RX1A			RXD inputs (receive data) channel 1
	CAN03_RXDA			CAN receive input node 3
	CAN21_RXDA			CAN receive input node 1
	PSI5S_RXA			RX data input
	SENT_SENT2B			Receive input channel 2
	CIF_D12			sensor pixel data input
	CCU61_CC61INA			T12 capture input 61
	EVADC_G9CH9	AI	Analog input channel 9, group 9	
	EDSADC_EDS5NB		Negative analog input channel 5, pin B	
	P00.3	O0	General-purpose output	
	GTM_TOUT12	O1	GTM muxed output	
	IOM_REF0_12		Reference input 0	
	ASCLIN3_ASLSO	O2	Slave select signal output	
—	O3	Reserved		
EDSADC_DSCOUT3	O4	Modulator clock output		
—	O5	Reserved		
SENT_SPC2	O6	Transmit output		
CCU61_CC61	O7	T12 PWM channel 61		
IOM_MON1_9		Monitor input 1		
IOM_REF1_12		Reference input 1		

TC37xEXT Pin Definition and Functions LFBGA-292 Package Pinning of

Table 2-1 Port 00 Functions (cont'd)

Ball	Symbol	Ctrl.	Buffer Type	Function	
J1	P00.4	I	SLOW / PU1 / VEXT / ES1	General-purpose input	
	GTM_TIM3_IN3_1			Mux input channel 3 of TIM module 3	
	GTM_TIM2_IN3_1			Mux input channel 3 of TIM module 2	
	SCU_E_REQ2_2			ERU Channel 2 inputs 0 to 5 (0 is the LSB and 5 is the MSB)	
	SENT_SENT3B			Receive input channel 3	
	EDSADC_DSDIN3A			Digital datastream input, channel 3	
	EDSADC_SGNA			Carrier sign signal input	
	ASCLIN10_ARXA			Receive input	
	CIF_D13			sensor pixel data input	
	EVADC_G9CH8			AI	Analog input channel 8, group 9
	EDSADC_EDS5PB				Positive analog input channel 5, pin B
	P00.4			O0	General-purpose output
	GTM_TOUT13			O1	GTM muxed output
	IOM_REF0_13		Reference input 0		
	PSI5S_TX	O2	TX data output		
	CAN11_TXD	O3	CAN transmit output node 1		
	PSI5_TX1	O4	TXD outputs (send data)		
	IOM_MON1_15		Monitor input 1		
	—	O5	Reserved		
	SENT_SPC3	O6	Transmit output		
	CCU61_COUT61	O7	T12 PWM channel 61		
	IOM_MON1_12		Monitor input 1		
	IOM_REF1_9		Reference input 1		

TC37xEXT Pin Definition and Functions LFBGA-292 Package Pinning of

Table 2-1 Port 00 Functions (cont'd)

Ball	Symbol	Ctrl.	Buffer Type	Function	
J2	P00.5	I	SLOW / PU1 / VEXT / ES1	General-purpose input	
	GTM_TIM3_IN4_1			Mux input channel 4 of TIM module 3	
	GTM_TIM3_IN0_11			Mux input channel 0 of TIM module 3	
	GTM_TIM2_IN4_1			Mux input channel 4 of TIM module 2	
	CCU60_CC62INB			T12 capture input 62	
	EDSADC_DSCIN2A			Modulator clock input, channel 2	
	CCU61_CC62INA			T12 capture input 62	
	SENT_SENT4B			Receive input channel 4	
	CIF_D14			sensor pixel data input	
	CAN11_RXDB			CAN receive input node 1	
	GTM_DTMT1_1			CDTM1_DTM0	
	EVADC_G9CH7			AI	Analog input channel 7, group 9
	P00.5			O0	General-purpose output
	GTM_TOUT14	O1	GTM muxed output		
	IOM_REF0_14		Reference input 0		
	EDSADC_CGPWMN	O2	Negative carrier generator output		
	QSPI3_SLSO3	O3	Master slave select output		
	EDSADC_DSCOUT2	O4	Modulator clock output		
	EVADC_FC0BFLOUT	O5	Boundary flag output, FC channel 0		
	SENT_SPC4	O6	Transmit output		
CCU61_CC62	O7	T12 PWM channel 62			
IOM_MON1_10		Monitor input 1			
IOM_REF1_11		Reference input 1			

TC37xEXT Pin Definition and Functions LFBGA-292 Package Pinning of

Table 2-1 Port 00 Functions (cont'd)

Ball	Symbol	Ctrl.	Buffer Type	Function
J4	P00.6	I	SLOW / PU1 / VEXT / ES1	General-purpose input
	GTM_TIM3_IN5_1			Mux input channel 5 of TIM module 3
	GTM_TIM3_IN1_14			Mux input channel 1 of TIM module 3
	GTM_TIM2_IN5_1			Mux input channel 5 of TIM module 2
	EDSADC_ITR4F			Trigger/Gate input, channel 4
	EDSADC_DSDIN2A			Digital datastream input, channel 2
	SENT_SENT5B			Receive input channel 5
	CIF_D15			sensor pixel data input
	ASCLIN5_ARXA			Receive input
	EVADC_G9CH6			AI
	P00.6	O0	General-purpose output	
	GTM_TOUT15	O1	GTM muxed output	
	IOM_REF0_15		Reference input 0	
	EDSADC_CGPWMP	O2	Positive carrier generator output	
	—	O3	Reserved	
	—	O4	Reserved	
	EVADC_EMUX10	O5	Control of external analog multiplexer interface 1	
	SENT_SPC5	O6	Transmit output	
	CCU61_COUT62	O7	T12 PWM channel 62	
	IOM_MON1_13		Monitor input 1	
IOM_REF1_8		Reference input 1		

TC37xEXT Pin Definition and Functions LFBGA-292 Package Pinning of

Table 2-1 Port 00 Functions (cont'd)

Ball	Symbol	Ctrl.	Buffer Type	Function
K1	P00.7	I	SLOW / PU1 / VEXT / ES1	General-purpose input
	GTM_TIM3_IN6_1			Mux input channel 6 of TIM module 3
	GTM_TIM3_IN2_11			Mux input channel 2 of TIM module 3
	GTM_TIM2_IN6_1			Mux input channel 6 of TIM module 2
	CCU61_CC60INC			T12 capture input 60
	SENT_SENT6B			Receive input channel 6
	EDSADC_DSCIN4A			Modulator clock input, channel 4
	GPT120_T2INA			Trigger/gate input of timer T2
	CCU61_CCPOS0A			Hall capture input 0
	CCU60_T12HRB			External timer start 12
	CIF_PCLK			Sensor Pixel Clock input
	GTM_DTMT0_2			CDTM0_DTM0
	EVADC_G9CH5			AI
	EDSADC_EDS4NA	Negative analog input channel 4, pin A		
	P00.7	O0	General-purpose output	
	GTM_TOUT16	O1	GTM muxed output	
	ASCLIN5_ATX	O2	Transmit output	
	EVADC_FC2BFLOUT	O3	Boundary flag output, FC channel 2	
	EDSADC_DSCOUT4	O4	Modulator clock output	
	EVADC_EMUX11	O5	Control of external analog multiplexer interface 1	
	SENT_SPC6	O6	Transmit output	
	CCU61_CC60	O7	T12 PWM channel 60	
	IOM_MON1_8		Monitor input 1	
IOM_REF1_13	Reference input 1			

TC37xEXT Pin Definition and Functions LFBGA-292 Package Pinning of

Table 2-1 Port 00 Functions (cont'd)

Ball	Symbol	Ctrl.	Buffer Type	Function
K4	P00.8	I	SLOW / PU1 / VEXT / ES1	General-purpose input
	GTM_TIM3_IN7_1			Mux input channel 7 of TIM module 3
	GTM_TIM3_IN3_11			Mux input channel 3 of TIM module 3
	GTM_TIM2_IN7_1			Mux input channel 7 of TIM module 2
	CCU61_CC61INC			T12 capture input 61
	SENT_SENT7B			Receive input channel 7
	EDSADC_DSDIN4A			Digital datastream input, channel 4
	GPT120_T2EUDA			Count direction control input of timer T2
	CCU61_CCPOS1A			Hall capture input 1
	CIF_VSYNC			vertical synchronization signal input
	CCU60_T13HRB			External timer start 13
	ASCLIN10_ARXB			Receive input
	EVADC_G9CH4			AI
	EDSADC_EDS4PA	Positive analog input channel 4, pin A		
	P00.8	O0	General-purpose output	
	GTM_TOUT17	O1	GTM muxed output	
	QSPI3_SLSO6	O2	Master slave select output	
	ASCLIN10_ATX	O3	Transmit output	
	—	O4	Reserved	
	EVADC_EMUX12	O5	Control of external analog multiplexer interface 1	
	SENT_SPC7	O6	Transmit output	
	CCU61_CC61	O7	T12 PWM channel 61	
	IOM_MON1_9		Monitor input 1	
IOM_REF1_12	Reference input 1			

TC37xEXT Pin Definition and Functions LFBGA-292 Package Pinning of

Table 2-1 Port 00 Functions (cont'd)

Ball	Symbol	Ctrl.	Buffer Type	Function
K2	P00.9	I	SLOW / PU1 / VEXT / ES1	General-purpose input
	GTM_TIM4_IN0_7			Mux input channel 0 of TIM module 4
	GTM_TIM1_IN0_1			Mux input channel 0 of TIM module 1
	GTM_TIM0_IN0_1			Mux input channel 0 of TIM module 0
	CCU61_CC62INC			T12 capture input 62
	SENT_SENT8B			Receive input channel 8
	CCU61_CCPOS2A			Hall capture input 2
	EDSADC_DSCIN1A			Modulator clock input, channel 1
	EDSADC_ITR3F			Trigger/Gate input, channel 3
	GPT120_T4EUDA			Count direction control input of timer T4
	CCU60_T13HRC			External timer start 13
	CIF_HSYNC			horizontal synchronization signal input
	CCU60_T12HRC			External timer start 12
	EVADC_G9CH3			AI
	EDSADC_EDS4NB		Negative analog input channel 4, pin B	
	P00.9	O0	General-purpose output	
	GTM_TOUT18	O1	GTM muxed output	
	QSPI3_SLSO7	O2	Master slave select output	
	ASCLIN3_ARTS	O3	Ready to send output	
	EDSADC_DSCOUT1	O4	Modulator clock output	
	ASCLIN4_ATX	O5	Transmit output	
	SENT_SPC8	O6	Transmit output	
	CCU61_CC62	O7	T12 PWM channel 62	
IOM_MON1_10		Monitor input 1		
IOM_REF1_11		Reference input 1		

TC37xEXT Pin Definition and Functions LFBGA-292 Package Pinning of

Table 2-1 Port 00 Functions (cont'd)

Ball	Symbol	Ctrl.	Buffer Type	Function
K5	P00.10	I	SLOW / PU1 / VEXT / ES1	General-purpose input
	GTM_TIM4_IN1_11			Mux input channel 1 of TIM module 4
	GTM_TIM1_IN1_1			Mux input channel 1 of TIM module 1
	GTM_TIM0_IN1_1			Mux input channel 1 of TIM module 0
	SENT_SENT9B			Receive input channel 9
	EDSADC_DSDIN1A			Digital datastream input, channel 1
	EVADC_G9CH2			Analog input channel 2, group 9
	EDSADC_EDS4PB	AI	Positive analog input channel 4, pin B	
	P00.10	O0	General-purpose output	
	GTM_TOUT19	O1	GTM muxed output	
	ASCLIN4_ASCLK	O2	Shift clock output	
	—	O3	Reserved	
	—	O4	Reserved	
	—	O5	Reserved	
	SENT_SPC9	O6	Transmit output	
	CCU61_COUT63	O7	T13 PWM channel 63	
	IOM_MON1_7		Monitor input 1	
IOM_REF1_7		Reference input 1		
L1	P00.11	I	SLOW / PU1 / VEXT / ES1	General-purpose input
	GTM_TIM4_IN2_11			Mux input channel 2 of TIM module 4
	GTM_TIM1_IN2_1			Mux input channel 2 of TIM module 1
	GTM_TIM0_IN2_1			Mux input channel 2 of TIM module 0
	CCU60_CTRAPA			Trap input capture
	EDSADC_DSCIN0A			Modulator clock input, channel 0
	CCU61_T12HRE			External timer start 12
	SENT_SENT10B	Receive input channel 10		
	EVADC_G9CH1	AI	Analog input channel 1, group 9	
	EVADC_FC3CH0		Analog input FC channel 3	
	P00.11	O0	General-purpose output	
	GTM_TOUT20	O1	GTM muxed output	
	ASCLIN4_ASLSO	O2	Slave select signal output	
	—	O3	Reserved	
	EDSADC_DSCOUT0	O4	Modulator clock output	
	—	O5	Reserved	
	—	O6	Reserved	
—	O7	Reserved		

TC37xEXT Pin Definition and Functions LFBGA-292 Package Pinning of

Table 2-1 Port 00 Functions (cont'd)

Ball	Symbol	Ctrl.	Buffer Type	Function
L2	P00.12	I	SLOW / PU1 / VEXT / ES1	General-purpose input
	GTM_TIM4_IN3_11			Mux input channel 3 of TIM module 4
	GTM_TIM1_IN3_1			Mux input channel 3 of TIM module 1
	GTM_TIM0_IN3_1			Mux input channel 3 of TIM module 0
	ASCLIN3_ACTSA			Clear to send input
	EDSADC_DSDIN0A			Digital datastream input, channel 0
	ASCLIN4_ARXA			Receive input
	SENT_SENT11B			Receive input channel 11
	EVADC_G9CH0			AI
	EVADC_FC2CH0	Analog input FC channel 2		
	P00.12	O0	General-purpose output	
	GTM_TOUT21	O1	GTM muxed output	
	—	O2	Reserved	
	—	O3	Reserved	
	—	O4	Reserved	
	—	O5	Reserved	
	—	O6	Reserved	
	CCU61_COUT63	O7	T13 PWM channel 63	
	IOM_MON1_7		Monitor input 1	
	IOM_REF1_7		Reference input 1	

TC37xEXT Pin Definition and Functions LFBGA-292 Package Pinning of

Table 2-2 Port 01 Functions

Ball	Symbol	Ctrl.	Buffer Type	Function
G5	P01.3	I	SLOW / PU1 / VEXT / ES	General-purpose input
	GTM_TIM4_IN5_2			Mux input channel 5 of TIM module 4
	GTM_TIM2_IN0_14			Mux input channel 0 of TIM module 2
	GTM_TIM0_IN5_8			Mux input channel 5 of TIM module 0
	QSPI3_SLSIB			Slave select input
	EVADC_G9CH14	AI		Analog input channel 14, group 9
	P01.3	O0		General-purpose output
	GTM_TOUT111	O1		GTM muxed output
	—	O2		Reserved
	—	O3		Reserved
	QSPI3_SLSO9	O4		Master slave select output
	CAN01_TXD	O5		CAN transmit output node 1
	IOM_MON2_6			Monitor input 2
	IOM_REF2_6			Reference input 2
	—	O6		Reserved
—	O7		Reserved	
G4	P01.4	I	SLOW / PU1 / VEXT / ES	General-purpose input
	GTM_TIM4_IN6_2			Mux input channel 6 of TIM module 4
	GTM_TIM2_IN1_14			Mux input channel 1 of TIM module 2
	GTM_TIM0_IN6_8			Mux input channel 6 of TIM module 0
	CAN01_RXDC			CAN receive input node 1
	EVADC_G9CH13	AI		Analog input channel 13, group 9
	P01.4	O0		General-purpose output
	GTM_TOUT112	O1		GTM muxed output
	—	O2		Reserved
	ASCLIN9_ASLSO	O3		Slave select signal output
	QSPI3_SLSO10	O4		Master slave select output
	—	O5		Reserved
	—	O6		Reserved
	—	O7		Reserved

TC37xEXT Pin Definition and Functions LFBGA-292 Package Pinning of

Table 2-2 Port 01 Functions (cont'd)

Ball	Symbol	Ctrl.	Buffer Type	Function
H5	P01.5	I	SLOW / PU1 / VEXT / ES	General-purpose input
	GTM_TIM5_IN3_2			Mux input channel 3 of TIM module 5
	GTM_TIM2_IN3_7			Mux input channel 3 of TIM module 2
	GTM_TIM2_IN2_7			Mux input channel 2 of TIM module 2
	QSPI3_MRSTC			Master SPI data input
	ASCLIN9_ARXA			Receive input
	EVADC_G9CH12			AI
	P01.5	O0	General-purpose output	
	GTM_TOUT113	O1	GTM muxed output	
	—	O2	Reserved	
	—	O3	Reserved	
	QSPI3_MRST	O4	Slave SPI data output	
	IOM_MON2_3		Monitor input 2	
	IOM_REF2_3		Reference input 2	
	—	O5	Reserved	
	—	O6	Reserved	
	—	O7	Reserved	
H4	P01.6	I	FAST / PU1 / VEXT / ES	General-purpose input
	GTM_TIM5_IN6_2			Mux input channel 6 of TIM module 5
	GTM_TIM5_IN5_3			Mux input channel 5 of TIM module 5
	GTM_TIM2_IN5_7			Mux input channel 5 of TIM module 2
	QSPI3_MTSRC			Slave SPI data input
	P01.6	O0	General-purpose output	
	GTM_TOUT114	O1	GTM muxed output	
	—	O2	Reserved	
	ASCLIN9_ASCLK	O3	Shift clock output	
	QSPI3_MTSR	O4	Master SPI data output	
	—	O5	Reserved	
	—	O6	Reserved	
	—	O7	Reserved	

TC37xEXT Pin Definition and Functions LFBGA-292 Package Pinning of

Table 2-2 Port 01 Functions (cont'd)

Ball	Symbol	Ctrl.	Buffer Type	Function
J5	P01.7	I	FAST / PU1 / VEXT / ES	General-purpose input
	GTM_TIM5_IN7_2			Mux input channel 7 of TIM module 5
	GTM_TIM2_IN7_7			Mux input channel 7 of TIM module 2
	QSPI3_SCLKC			Slave SPI clock inputs
	ASCLIN9_ARXB			Receive input
	P01.7	O0		General-purpose output
	GTM_TOUT115	O1		GTM muxed output
	—	O2		Reserved
	ASCLIN9_ATX	O3		Transmit output
	QSPI3_SCLK	O4		Master SPI clock output
	—	O5		Reserved
	—	O6		Reserved
	—	O7		Reserved

TC37xEXT Pin Definition and Functions LFBGA-292 Package Pinning of

Table 2-3 Port 02 Functions

Ball	Symbol	Ctrl.	Buffer Type	Function
B1	P02.0	I	FAST / PU1 / VEXT / ES	General-purpose input
	GTM_TIM1_IN0_2			Mux input channel 0 of TIM module 1
	GTM_TIM0_IN0_2			Mux input channel 0 of TIM module 0
	CCU61_CC60INB			T12 capture input 60
	ASCLIN2_ARXG			Receive input
	CCU60_CC60INA			T12 capture input 60
	SCU_E_REQ3_2			ERU Channel 3 inputs 0 to 5 (0 is the LSB and 5 is the MSB)
	CIF_D0			sensor pixel data input
	GTM_DTMA0_0			CDTM0_DTM4
	P02.0			O0
	GTM_TOUT0	O1	GTM muxed output	
	IOM_REF0_0	O2	Reference input 0	
	ASCLIN2_ATX		Transmit output	
	IOM_MON2_14		Monitor input 2	
	IOM_REF2_14	O3	Reference input 2	
	QSPI3_SLSO1		Master slave select output	
	EDSADC_CGPWMN	O4	Negative carrier generator output	
	CAN00_TXD	O5	CAN transmit output node 0	
	IOM_MON2_5	O6	Monitor input 2	
	IOM_REF2_5		Reference input 2	
	ERAY0_TXDA	O7	Transmit Channel A	
	CCU60_CC60		T12 PWM channel 60	
	IOM_MON1_2		Monitor input 1	
	IOM_REF1_6		Reference input 1	

TC37xEXT Pin Definition and Functions LFBGA-292 Package Pinning of

Table 2-3 Port 02 Functions (cont'd)

Ball	Symbol	Ctrl.	Buffer Type	Function
C2	P02.1	I	SLOW / PU1 / VEXT / ES	General-purpose input
	GTM_TIM1_IN1_2			Mux input channel 1 of TIM module 1
	GTM_TIM0_IN1_2			Mux input channel 1 of TIM module 0
	ERAY0_RXDA2			Receive Channel A2
	ASCLIN2_ARXB			Receive input
	CAN00_RXDA			CAN receive input node 0
	SCU_E_REQ2_1			ERU Channel 2 inputs 0 to 5 (0 is the LSB and 5 is the MSB)
	CIF_D1			sensor pixel data input
	P02.1			O0
	GTM_TOUT1	O1	GTM muxed output	
	IOM_REF0_1		Reference input 0	
	QSPI4_SLSO7	O2	Master slave select output	
	QSPI3_SLSO2	O3	Master slave select output	
	EDSADC_CGPWMP	O4	Positive carrier generator output	
	—	O5	Reserved	
	—	O6	Reserved	
	CCU60_COUT60	O7	T12 PWM channel 60	
	IOM_MON1_3		Monitor input 1	
	IOM_REF1_3		Reference input 1	

TC37xEXT Pin Definition and Functions LFBGA-292 Package Pinning of

Table 2-3 Port 02 Functions (cont'd)

Ball	Symbol	Ctrl.	Buffer Type	Function
C1	P02.2	I	FAST / PU1 / VEXT / ES	General-purpose input
	GTM_TIM1_IN2_2			Mux input channel 2 of TIM module 1
	GTM_TIM0_IN2_2			Mux input channel 2 of TIM module 0
	CCU61_CC61INB			T12 capture input 61
	CCU60_CC61INA			T12 capture input 61
	CIF_D2			sensor pixel data input
	SENT_SENT14B			Receive input channel 14
	P02.2			O0
	GTM_TOUT2	O1	GTM muxed output	
	IOM_REF0_2	O2	Reference input 0	
	ASCLIN1_ATX		Transmit output	
	IOM_MON2_13		Monitor input 2	
	IOM_REF2_13	Reference input 2		
	QSPI3_SLSO3	O3	Master slave select output	
	PSI5_TX0	O4	TXD outputs (send data)	
	IOM_MON1_14	O5	Monitor input 1	
	IOM_REF1_14		Reference input 1	
	CAN02_TXD		CAN transmit output node 2	
	IOM_MON2_7	Monitor input 2		
	IOM_REF2_7	Reference input 2		
	ERAY0_TXDB	O6	Transmit Channel B	
	CCU60_CC61	O7	T12 PWM channel 61	
	IOM_MON1_1	Monitor input 1		
	IOM_REF1_5	Reference input 1		

TC37xEXT Pin Definition and Functions LFBGA-292 Package Pinning of

Table 2-3 Port 02 Functions (cont'd)

Ball	Symbol	Ctrl.	Buffer Type	Function
D2	P02.3	I	SLOW / PU1 / VEXT / ES	General-purpose input
	GTM_TIM1_IN3_2			Mux input channel 3 of TIM module 1
	GTM_TIM0_IN3_2			Mux input channel 3 of TIM module 0
	EDSADC_DSCIN5B			Modulator clock input, channel 5
	ERAY0_RXDB2			Receive Channel B2
	CAN02_RXDB			CAN receive input node 2
	ASCLIN1_ARXG			Receive input
	MSC1_SD11			Upstream asynchronous input signal
	PSI5_RX0B			RXD inputs (receive data) channel 0
	CIF_D3			sensor pixel data input
	SENT_SENT13B			Receive input channel 13
	P02.3			O0
	GTM_TOUT3	O1	GTM muxed output	
	IOM_REF0_3		Reference input 0	
	ASCLIN2_ASLSO	O2	Slave select signal output	
	QSPI3_SLSO4	O3	Master slave select output	
	EDSADC_DSCOUT5	O4	Modulator clock output	
	—	O5	Reserved	
	—	O6	Reserved	
CCU60_COUT61	O7	T12 PWM channel 61		
IOM_MON1_4		Monitor input 1		
IOM_REF1_2		Reference input 1		

TC37xEXT Pin Definition and Functions LFBGA-292 Package Pinning of

Table 2-3 Port 02 Functions (cont'd)

Ball	Symbol	Ctrl.	Buffer Type	Function
D1	P02.4	I	FAST / PU1 / VEXT / ES	General-purpose input
	GTM_TIM1_IN4_1			Mux input channel 4 of TIM module 1
	GTM_TIM0_IN4_1			Mux input channel 4 of TIM module 0
	CCU61_CC62INB			T12 capture input 62
	EDSADC_DSDIN5B			Digital datastream input, channel 5
	QSPI3_SLSIA			Slave select input
	CCU60_CC62INA			T12 capture input 62
	I2C0_SDAA			Serial Data Input 0
	CAN11_RXDA			CAN receive input node 1
	CAN0_ECTT1			External CAN time trigger input
	CIF_D4			sensor pixel data input
	SENT_SENT12B			Receive input channel 12
	P02.4			O0
	GTM_TOUT4	O1	GTM muxed output	
	IOM_REF0_4		Reference input 0	
	ASCLIN2_ASCLK	O2	Shift clock output	
	QSPI3_SLSO0	O3	Master slave select output	
	PSI5S_CLK	O4	PSI5S CLK is a clock that can be used on a pin to drive the external PHY.	
	I2C0_SDA	O5	Serial Data Output	
	ERAY0_TXENA	O6	Transmit Enable Channel A	
CCU60_CC62	O7	T12 PWM channel 62		
IOM_MON1_0		Monitor input 1		
IOM_REF1_4		Reference input 1		

TC37xEXT Pin Definition and Functions LFBGA-292 Package Pinning of

Table 2-3 Port 02 Functions (cont'd)

Ball	Symbol	Ctrl.	Buffer Type	Function	
E2	P02.5	I	FAST / PU1 / VEXT / ES	General-purpose input	
	GTM_TIM1_IN5_1			Mux input channel 5 of TIM module 1	
	GTM_TIM0_IN5_1			Mux input channel 5 of TIM module 0	
	EDSADC_DSCIN4B			Modulator clock input, channel 4	
	I2C0_SCLA			Serial Clock Input 0	
	PSI5_RX1B			RXD inputs (receive data) channel 1	
	PSI5S_RXB			RX data input	
	QSPI3_MRSTA			Master SPI data input	
	SENT_SENT3C			Receive input channel 3	
	CAN0_ECTT2			External CAN time trigger input	
	CIF_D5			sensor pixel data input	
	P02.5			O0	General-purpose output
	GTM_TOUT5			O1	GTM muxed output
	IOM_REF0_5		Reference input 0		
	CAN11_TXD	O2	CAN transmit output node 1		
	QSPI3_MRST	O3	Slave SPI data output		
	IOM_MON2_3		Monitor input 2		
	IOM_REF2_3		Reference input 2		
	EDSADC_DSCOUT4	O4	Modulator clock output		
	I2C0_SCL	O5	Serial Clock Output		
ERAY0_TXENB	O6	Transmit Enable Channel B			
CCU60_COUT62	O7	T12 PWM channel 62			
IOM_MON1_5		Monitor input 1			
IOM_REF1_1		Reference input 1			

TC37xEXT Pin Definition and Functions LFBGA-292 Package Pinning of

Table 2-3 Port 02 Functions (cont'd)

Ball	Symbol	Ctrl.	Buffer Type	Function
E1	P02.6	I	FAST / PU1 / VEXT / ES	General-purpose input
	GTM_TIM3_IN0_10			Mux input channel 0 of TIM module 3
	GTM_TIM1_IN6_1			Mux input channel 6 of TIM module 1
	GTM_TIM0_IN6_1			Mux input channel 6 of TIM module 0
	CCU60_CC60INC			T12 capture input 60
	SENT_SENT2C			Receive input channel 2
	EDSADC_DSDIN4B			Digital datastream input, channel 4
	EDSADC_ITR5E			Trigger/Gate input, channel 5
	GPT120_T3INA			Trigger/gate input of core timer T3
	CCU60_CCPOS0A			Hall capture input 0
	CCU61_T12HRB			External timer start 12
	QSPI3_MTSRA			Slave SPI data input
	CIF_D6			sensor pixel data input
	P02.6			O0
	GTM_TOUT6	O1	GTM muxed output	
	IOM_REF0_6		Reference input 0	
	PSI5S_TX	O2	TX data output	
	QSPI3_MTSR	O3	Master SPI data output	
	PSI5_TX1	O4	TXD outputs (send data)	
	IOM_MON1_15		Monitor input 1	
EVADC_EMUX00	O5	Control of external analog multiplexer interface 0		
—	O6	Reserved		
CCU60_CC60	O7	T12 PWM channel 60		
IOM_MON1_2		Monitor input 1		
IOM_REF1_6		Reference input 1		

TC37xEXT Pin Definition and Functions LFBGA-292 Package Pinning of

Table 2-3 Port 02 Functions (cont'd)

Ball	Symbol	Ctrl.	Buffer Type	Function
F2	P02.7	I	FAST / PU1 / VEXT / ES	General-purpose input
	GTM_TIM3_IN1_10			Mux input channel 1 of TIM module 3
	GTM_TIM1_IN7_1			Mux input channel 7 of TIM module 1
	GTM_TIM0_IN7_1			Mux input channel 7 of TIM module 0
	CCU60_CC61INC			T12 capture input 61
	SENT_SENT1C			Receive input channel 1
	EDSADC_DSCIN3B			Modulator clock input, channel 3
	EDSADC_ITR4E			Trigger/Gate input, channel 4
	GPT120_T3EUDA			Count direction control input of core timer T3
	CCU60_CCPOS1A			Hall capture input 1
	CIF_D7			sensor pixel data input
	QSPI3_SCLKA			Slave SPI clock inputs
	CCU61_T13HRB			External timer start 13
	P02.7			O0
	GTM_TOUT7	O1	GTM muxed output	
	IOM_REF0_7		Reference input 0	
	—	O2	Reserved	
	QSPI3_SCLK	O3	Master SPI clock output	
	EDSADC_DSCOUT3	O4	Modulator clock output	
	EVADC_EMUX01	O5	Control of external analog multiplexer interface 0	
SENT_SPC1	O6	Transmit output		
CCU60_CC61	O7	T12 PWM channel 61		
IOM_MON1_1		Monitor input 1		
IOM_REF1_5		Reference input 1		

TC37xEXT Pin Definition and Functions LFBGA-292 Package Pinning of

Table 2-3 Port 02 Functions (cont'd)

Ball	Symbol	Ctrl.	Buffer Type	Function
F1	P02.8	I	SLOW / PU1 / VEXT / ES	General-purpose input
	GTM_TIM3_IN2_10			Mux input channel 2 of TIM module 3
	GTM_TIM3_IN0_2			Mux input channel 0 of TIM module 3
	GTM_TIM2_IN0_2			Mux input channel 0 of TIM module 2
	CCU60_CC62INC			T12 capture input 62
	SENT_SENT0C			Receive input channel 0
	CCU60_CCPOS2A			Hall capture input 2
	EDSADC_DSDIN3B			Digital datastream input, channel 3
	EDSADC_ITR3E			Trigger/Gate input, channel 3
	GPT120_T4INA			Trigger/gate input of timer T4
	CCU61_T12HRC			External timer start 12
	CIF_D8			sensor pixel data input
	CCU61_T13HRC			External timer start 13
	GTM_DTMA0_1			CDTM0_DTM4
	P02.8			O0
	GTM_TOUT8	O1	GTM muxed output	
	IOM_REF0_8		Reference input 0	
	QSPI3_SLSO5	O2	Master slave select output	
	ASCLIN8_ASCLK	O3	Shift clock output	
	—	O4	Reserved	
EVADC_EMUX02	O5	Control of external analog multiplexer interface 0		
GETH_MDC	O6	MDIO clock		
CCU60_CC62	O7	T12 PWM channel 62		
IOM_MON1_0		Monitor input 1		
IOM_REF1_4		Reference input 1		

TC37xEXT Pin Definition and Functions LFBGA-292 Package Pinning of

Table 2-3 Port 02 Functions (cont'd)

Ball	Symbol	Ctrl.	Buffer Type	Function	
E4	P02.9	I	SLOW / PU1 / VEXT / ES	General-purpose input	
	GTM_TIM4_IN2_2			Mux input channel 2 of TIM module 4	
	GTM_TIM3_IN3_10			Mux input channel 3 of TIM module 3	
	GTM_TIM0_IN2_10			Mux input channel 2 of TIM module 0	
	ASCLIN8_ARXA			Receive input	
	P02.9			O0	General-purpose output
	GTM_TOUT116			O1	GTM muxed output
	ASCLIN2_ATX			O2	Transmit output
	IOM_MON2_14				Monitor input 2
	IOM_REF2_14				Reference input 2
	ASCLIN8_ATX	O3	Transmit output		
	—	O4	Reserved		
	CAN01_TXD	O5	CAN transmit output node 1		
	IOM_MON2_6		Monitor input 2		
	IOM_REF2_6		Reference input 2		
	—	O6	Reserved		
—	O7	Reserved			
F5	P02.10	I	SLOW / PU1 / VEXT / ES	General-purpose input	
	GTM_TIM4_IN3_2			Mux input channel 3 of TIM module 4	
	GTM_TIM3_IN4_11			Mux input channel 4 of TIM module 3	
	GTM_TIM0_IN3_10			Mux input channel 3 of TIM module 0	
	ASCLIN2_ARXC			Receive input	
	CAN01_RXDE			CAN receive input node 1	
	ASCLIN8_ARXB			Receive input	
	P02.10			O0	General-purpose output
	GTM_TOUT117			O1	GTM muxed output
	—			O2	Reserved
	—	O3	Reserved		
	—	O4	Reserved		
	—	O5	Reserved		
	—	O6	Reserved		
	—	O7	Reserved		

TC37xEXT Pin Definition and Functions LFBGA-292 Package Pinning of

Table 2-3 Port 02 Functions (cont'd)

Ball	Symbol	Ctrl.	Buffer Type	Function
F4	P02.11	I	SLOW / PU1 / VEXT / ES	General-purpose input
	GTM_TIM4_IN4_3			Mux input channel 4 of TIM module 4
	GTM_TIM3_IN5_12			Mux input channel 5 of TIM module 3
	GTM_TIM0_IN7_7			Mux input channel 7 of TIM module 0
	EVADC_G9CH15	AI		Analog input channel 15, group 9
	P02.11	O0		General-purpose output
	GTM_TOUT118	O1		GTM muxed output
	—	O2		Reserved
	ASCLIN8_ASLSO	O3		Slave select signal output
	—	O4		Reserved
	—	O5		Reserved
	—	O6		Reserved
	—	O7		Reserved

Table 2-4 Port 10 Functions

Ball	Symbol	Ctrl.	Buffer Type	Function
A7	P10.0	I	SLOW / PU1 / VEXT / ES	General-purpose input
	GTM_TIM4_IN0_12			Mux input channel 0 of TIM module 4
	GTM_TIM1_IN4_2			Mux input channel 4 of TIM module 1
	GTM_TIM0_IN4_2			Mux input channel 4 of TIM module 0
	GPT120_T6EUDB			Count direction control input of core timer T6
	ASCLIN11_ARXA			Receive input
	GETH_RXERC			Receive Error MII
	P10.0	O0		General-purpose output
	GTM_TOUT102	O1		GTM muxed output
	ASCLIN11_ATX	O2		Transmit output
	QSPI1_SLSO10	O3		Master slave select output
	—	O4		Reserved
	—	O5		Reserved
—	O6	Reserved		
—	O7	Reserved		

TC37xEXT Pin Definition and Functions LFBGA-292 Package Pinning of

Table 2-4 Port 10 Functions (cont'd)

Ball	Symbol	Ctrl.	Buffer Type	Function	
B7	P10.1	I	FAST / PU1 / VEXT / ES	General-purpose input	
	GTM_TIM4_IN4_12			Mux input channel 4 of TIM module 4	
	GTM_TIM1_IN1_3			Mux input channel 1 of TIM module 1	
	GTM_TIM0_IN1_3			Mux input channel 1 of TIM module 0	
	GPT120_T5EUDB			Count direction control input of timer T5	
	QSPI1_MRSTA			Master SPI data input	
	GTM_DTMT0_1			CDTM0_DTM0	
	P10.1			O0	General-purpose output
	GTM_TOUT103			O1	GTM muxed output
	QSPI1_MTSR			O2	Master SPI data output
	QSPI1_MRST			O3	Slave SPI data output
	IOM_MON2_1				Monitor input 2
	IOM_REF2_1				Reference input 2
	MSC0_EN1			O4	Chip Select
	EVADC_FC1BFLOUT			O5	Boundary flag output, FC channel 1
	—			O6	Reserved
	—			O7	Reserved
A5	P10.2	I	FAST / PU1 / VEXT / ES	General-purpose input	
	GTM_TIM4_IN5_12			Mux input channel 5 of TIM module 4	
	GTM_TIM1_IN2_3			Mux input channel 2 of TIM module 1	
	GTM_TIM0_IN2_3			Mux input channel 2 of TIM module 0	
	CAN02_RXDE			CAN receive input node 2	
	MSC0_SD11			Upstream asynchronous input signal	
	QSPI1_SCLKA			Slave SPI clock inputs	
	GPT120_T6INB			Trigger/gate input of core timer T6	
	SCU_E_REQ2_0			ERU Channel 2 inputs 0 to 5 (0 is the LSB and 5 is the MSB)	
	GTM_DTMT2_2			CDTM2_DTM0	
	P10.2			O0	General-purpose output
	GTM_TOUT104			O1	GTM muxed output
	IOM_MON2_9				Monitor input 2
	—			O2	Reserved
	QSPI1_SCLK			O3	Master SPI clock output
	MSC0_EN0			O4	Chip Select
	EVADC_FC3BFLOUT			O5	Boundary flag output, FC channel 3
—	O6	Reserved			
—	O7	Reserved			

TC37xEXT Pin Definition and Functions LFBGA-292 Package Pinning of

Table 2-4 Port 10 Functions (cont'd)

Ball	Symbol	Ctrl.	Buffer Type	Function
A6	P10.3	I	FAST / PU1 / VEXT / ES	General-purpose input
	GTM_TIM4_IN6_10			Mux input channel 6 of TIM module 4
	GTM_TIM1_IN3_3			Mux input channel 3 of TIM module 1
	GTM_TIM0_IN3_3			Mux input channel 3 of TIM module 0
	QSPI1_MTSRA			Slave SPI data input
	SCU_E_REQ3_0			ERU Channel 3 inputs 0 to 5 (0 is the LSB and 5 is the MSB)
	GPT120_T5INB			Trigger/gate input of timer T5
	P10.3			O0
	GTM_TOUT105	O1	GTM muxed output	
	IOM_MON2_10		Monitor input 2	
	—	O2	Reserved	
	QSPI1_MTSR	O3	Master SPI data output	
	MSC0_EN0	O4	Chip Select	
	—	O5	Reserved	
	CAN02_TXD	O6	CAN transmit output node 2	
	IOM_MON2_7		Monitor input 2	
	IOM_REF2_7		Reference input 2	
	—	O7	Reserved	
	B6	P10.4	I	FAST / PU1 / VEXT / ES
GTM_TIM4_IN7_3		Mux input channel 7 of TIM module 4		
GTM_TIM1_IN6_2		Mux input channel 6 of TIM module 1		
GTM_TIM0_IN6_2		Mux input channel 6 of TIM module 0		
QSPI1_MTSRC		Slave SPI data input		
CCU60_CCPOS0C		Hall capture input 0		
GPT120_T3INB		Trigger/gate input of core timer T3		
ASCLIN11_ARXB		Receive input		
P10.4		O0	General-purpose output	
GTM_TOUT106		O1	GTM muxed output	
IOM_MON2_11			Monitor input 2	
—		O2	Reserved	
QSPI1_SLSO8		O3	Master slave select output	
QSPI1_MTSR		O4	Master SPI data output	
MSC0_EN0		O5	Chip Select	
—		O6	Reserved	
—		O7	Reserved	

TC37xEXT Pin Definition and Functions LFBGA-292 Package Pinning of

Table 2-4 Port 10 Functions (cont'd)

Ball	Symbol	Ctrl.	Buffer Type	Function
B5	P10.5	I	SLOW / PU2 / VEXT / ES	General-purpose input
	GTM_TIM4_IN3_13			Mux input channel 3 of TIM module 4
	GTM_TIM1_IN2_4			Mux input channel 2 of TIM module 1
	GTM_TIM0_IN2_4			Mux input channel 2 of TIM module 0
	PMS_HWCFG4IN			HWCFG4 pin input
	CAN20_RXDA			CAN receive input node 0
	MSC0_INJ1			Injection signal from port
	P10.5	O0	General-purpose output	
	GTM_TOUT107	O1	GTM muxed output	
	IOM_REF2_9	O2	Reference input 2	
	ASCLIN2_ATX		Transmit output	
	IOM_MON2_14		Monitor input 2	
	IOM_REF2_14	Reference input 2		
	QSPI3_SLSO8	O3	Master slave select output	
	QSPI1_SLSO9	O4	Master slave select output	
	GPT120_T6OUT	O5	External output for overflow/underflow detection of core timer T6	
	ASCLIN2_ASLSO	O6	Slave select signal output	
—	O7	Reserved		
A4	P10.6	I	SLOW / PU2 / VEXT / ES	General-purpose input
	GTM_TIM4_IN2_13			Mux input channel 2 of TIM module 4
	GTM_TIM1_IN3_4			Mux input channel 3 of TIM module 1
	GTM_TIM0_IN3_4			Mux input channel 3 of TIM module 0
	ASCLIN2_ARXD			Receive input
	QSPI3_MTSRB			Slave SPI data input
	PMS_HWCFG5IN			HWCFG5 pin input
	P10.6	O0	General-purpose output	
	GTM_TOUT108	O1	GTM muxed output	
	IOM_REF2_10	O2	Reference input 2	
	ASCLIN2_ASCLK		Shift clock output	
	QSPI3_MTSR		Master SPI data output	
	GPT120_T3OUT	O4	External output for overflow/underflow detection of core timer T3	
	CAN20_TXD	O5	CAN transmit output node 0	
	QSPI1_MRST	O6	Slave SPI data output	
	IOM_MON2_1	O7	Monitor input 2	
	IOM_REF2_1		Reference input 2	
—	O7	Reserved		

TC37xEXT Pin Definition and Functions LFBGA-292 Package Pinning of

Table 2-4 Port 10 Functions (cont'd)

Ball	Symbol	Ctrl.	Buffer Type	Function
A3	P10.7	I	SLOW / PU1 / VEXT / ES	General-purpose input
	GTM_TIM1_IN0_3			Mux input channel 0 of TIM module 1
	GTM_TIM0_IN0_3			Mux input channel 0 of TIM module 0
	GPT120_T3EUDB			Count direction control input of core timer T3
	ASCLIN2_ACTSA			Clear to send input
	QSPI3_MRSTB			Master SPI data input
	SCU_E_REQ0_2			ERU Channel 0 inputs 0 to 5 (0 is the LSB and 5 is the MSB)
	CCU60_CCPOS1C			Hall capture input 1
	P10.7			O0
	GTM_TOUT109	O1	GTM muxed output	
	IOM_REF2_11	O2	Reference input 2	
	—		Reserved	
	QSPI3_MRST		O3	Slave SPI data output
	IOM_MON2_3	O3	Monitor input 2	
	IOM_REF2_3		Reference input 2	
	—	O4	Reserved	
	CAN20_TXD	O5	CAN transmit output node 0	
	CAN12_TXD	O6	CAN transmit output node 2	
	—	O7	Reserved	

TC37xEXT Pin Definition and Functions LFBGA-292 Package Pinning of

Table 2-4 Port 10 Functions (cont'd)

Ball	Symbol	Ctrl.	Buffer Type	Function
B4	P10.8	I	SLOW / PU1 / VEXT / ES	General-purpose input
	GTM_TIM4_IN0_13			Mux input channel 0 of TIM module 4
	GTM_TIM1_IN5_2			Mux input channel 5 of TIM module 1
	GTM_TIM0_IN5_2			Mux input channel 5 of TIM module 0
	CAN12_RXDB			CAN receive input node 2
	GPT120_T4INB			Trigger/gate input of timer T4
	QSPI3_SCLKB			Slave SPI clock inputs
	SCU_E_REQ1_2			ERU Channel 1 inputs 0 to 5 (0 is the LSB and 5 is the MSB)
	CCU60_CCPOS2C			Hall capture input 2
	CAN20_RXDB			CAN receive input node 0
	P10.8	O0	General-purpose output	
	GTM_TOUT110	O1	GTM muxed output	
	ASCLIN2_ARTS	O2	Ready to send output	
	QSPI3_SCLK	O3	Master SPI clock output	
	—	O4	Reserved	
	—	O5	Reserved	
	—	O6	Reserved	
	—	O7	Reserved	

Table 2-5 Port 11 Functions

Ball	Symbol	Ctrl.	Buffer Type	Function
E10	P11.0	I	RFast / PU1 / VFLEX / ES	General-purpose input
	GTM_TIM4_IN0_4			Mux input channel 0 of TIM module 4
	GTM_TIM2_IN0_7			Mux input channel 0 of TIM module 2
	ASCLIN3_ARXB			Receive input
	GTM_DTMA2_1			CDTM2_DTM4
	P11.0	O0	General-purpose output	
	GTM_TOUT119	O1	GTM muxed output	
	ASCLIN3_ATX	O2	Transmit output	
	IOM_MON2_15		Monitor input 2	
	IOM_REF2_15		Reference input 2	
	—		O3	Reserved
	—	O4	Reserved	
	CAN11_TXD	O5	CAN transmit output node 1	
	GETH_TXD3	O6	Transmit Data	
	—	O7	Reserved	

TC37xEXT Pin Definition and Functions LFBGA-292 Package Pinning of

Table 2-5 Port 11 Functions (cont'd)

Ball	Symbol	Ctrl.	Buffer Type	Function
E9	P11.1	I	RFAST / PU1 / VFLEX / ES	General-purpose input
	GTM_TIM4_IN1_5			Mux input channel 1 of TIM module 4
	GTM_TIM2_IN1_6			Mux input channel 1 of TIM module 2
	P11.1	O0		General-purpose output
	GTM_TOUT120	O1		GTM muxed output
	ASCLIN3_ASCLK	O2		Shift clock output
	ASCLIN3_ATX	O3		Transmit output
	IOM_MON2_15			Monitor input 2
	IOM_REF2_15			Reference input 2
	—			O4
	CAN12_TXD	O5		CAN transmit output node 2
	GETH_TXD2	O6		Transmit Data
	—	O7		Reserved
A10	P11.2	I	RFAST / PU1 / VFLEX / ES	General-purpose input
	GTM_TIM3_IN1_3			Mux input channel 1 of TIM module 3
	GTM_TIM2_IN1_3			Mux input channel 1 of TIM module 2
	P11.2	O0		General-purpose output
	GTM_TOUT95	O1		GTM muxed output
	—	O2		Reserved
	QSPIO_SLSO5	O3		Master slave select output
	QSPI1_SLSO5	O4		Master slave select output
	MSC0_EN1	O5		Chip Select
	GETH_TXD1	O6		Transmit Data
	CCU60_COUT63	O7		T13 PWM channel 63
	IOM_MON1_6			Monitor input 1
	IOM_REF1_0			Reference input 1

TC37xEXT Pin Definition and Functions LFBGA-292 Package Pinning of

Table 2-5 Port 11 Functions (cont'd)

Ball	Symbol	Ctrl.	Buffer Type	Function
B10	P11.3	I	RFAST / PU1 / VFLEX / ES	General-purpose input
	GTM_TIM3_IN2_2			Mux input channel 2 of TIM module 3
	GTM_TIM2_IN2_2			Mux input channel 2 of TIM module 2
	MSC0_SDI3			Upstream asynchronous input signal
	QSPI1_MRSTB			Master SPI data input
	P11.3	O0	General-purpose output	
	GTM_TOUT96	O1	GTM muxed output	
	—	O2	Reserved	
	QSPI1_MRST	O3	Slave SPI data output	
	IOM_MON2_1		Monitor input 2	
	IOM_REF2_1		Reference input 2	
	ERAY0_TXDA	O4	Transmit Channel A	
	—	O5	Reserved	
	GETH_TXD0	O6	Transmit Data	
	CCU60_COUT62	O7	T12 PWM channel 62	
	IOM_MON1_5		Monitor input 1	
IOM_REF1_1	Reference input 1			
D10	P11.4	I	RFAST / PU1 / VFLEX / ES	General-purpose input
	GTM_TIM4_IN2_5			Mux input channel 2 of TIM module 4
	GTM_TIM2_IN2_6			Mux input channel 2 of TIM module 2
	GETH_RXCLKB			Receive Clock MII
	P11.4	O0	General-purpose output	
	GTM_TOUT121	O1	GTM muxed output	
	ASCLIN3_ASCLK	O2	Shift clock output	
	—	O3	Reserved	
	—	O4	Reserved	
	CAN13_TXD	O5	CAN transmit output node 3	
	GETH_TXER	O6	Transmit Error MII	
GETH_TXCLK	O7	Transmit Clock Output for RGMII		

TC37xEXT Pin Definition and Functions LFBGA-292 Package Pinning of

Table 2-5 Port 11 Functions (cont'd)

Ball	Symbol	Ctrl.	Buffer Type	Function
D8	P11.5	I	SLOW / RGMII_In put / PU1 / VFLEX / ES	General-purpose input
	GTM_TIM4_IN3_5			Mux input channel 3 of TIM module 4
	GTM_TIM2_IN3_8			Mux input channel 3 of TIM module 2
	GETH_TXCLKA			Transmit Clock Input for MII
	GETH_GREFCLK			Gigabit Reference Clock input for RGMII (125 MHz high precision)
	P11.5	O0	General-purpose output	
	GTM_TOUT122	O1	GTM muxed output	
	—	O2	Reserved	
	—	O3	Reserved	
	—	O4	Reserved	
	CAN20_TXD	O5	CAN transmit output node 0	
	—	O6	Reserved	
	—	O7	Reserved	
D9	P11.6	I	RFAST / PU1 / VFLEX / ES	General-purpose input
	GTM_TIM3_IN3_2			Mux input channel 3 of TIM module 3
	GTM_TIM2_IN3_2			Mux input channel 3 of TIM module 2
	QSPI1_SCLKB			Slave SPI clock inputs
	P11.6	O0	General-purpose output	
	GTM_TOUT97	O1	GTM muxed output	
	ERAY0_TXENB	O2	Transmit Enable Channel B	
	QSPI1_SCLK	O3	Master SPI clock output	
	ERAY0_TXENA	O4	Transmit Enable Channel A	
	MSC0_FCLP	O5	Shift-clock direct part of the differential signal	
	GETH_TXEN	O6	Transmit Enable MII and RMII	
	GETH_TCTL		Transmit Control for RGMII	
	CCU60_COUT61	O7	T12 PWM channel 61	
	IOM_MON1_4		Monitor input 1	
	IOM_REF1_2		Reference input 1	

TC37xEXT Pin Definition and Functions LFBGA-292 Package Pinning of

Table 2-5 Port 11 Functions (cont'd)

Ball	Symbol	Ctrl.	Buffer Type	Function
E8	P11.7	I	SLOW / RGMII_Input / PU1 / VFLEX / ES	General-purpose input
	GTM_TIM4_IN4_5			Mux input channel 4 of TIM module 4
	GTM_TIM2_IN4_7			Mux input channel 4 of TIM module 2
	GETH_RXD3A			Receive Data 3 MII and RGMII (RGMII can use RXD3A only)
	CAN11_RXDD			CAN receive input node 1
	P11.7	O0	General-purpose output	
	GTM_TOUT123	O1	GTM muxed output	
	—	O2	Reserved	
	—	O3	Reserved	
	—	O4	Reserved	
	—	O5	Reserved	
	—	O6	Reserved	
	—	O7	Reserved	
E7	P11.8	I	SLOW / RGMII_Input / PU1 / VFLEX / ES	General-purpose input
	GTM_TIM4_IN5_5			Mux input channel 5 of TIM module 4
	GTM_TIM2_IN5_8			Mux input channel 5 of TIM module 2
	GETH_RXD2A			Receive Data 2 MII and RGMII (RGMII can use RXD2A only)
	CAN12_RXDD			CAN receive input node 2
	P11.8	O0	General-purpose output	
	GTM_TOUT124	O1	GTM muxed output	
	—	O2	Reserved	
	—	O3	Reserved	
	—	O4	Reserved	
	—	O5	Reserved	
	—	O6	Reserved	
	—	O7	Reserved	

TC37xEXT Pin Definition and Functions LFBGA-292 Package Pinning of

Table 2-5 Port 11 Functions (cont'd)

Ball	Symbol	Ctrl.	Buffer Type	Function
A9	P11.9	I	FAST / RGMII_Input / PU1 / VFLEX / ES	General-purpose input
	GTM_TIM3_IN4_2			Mux input channel 4 of TIM module 3
	GTM_TIM2_IN4_2			Mux input channel 4 of TIM module 2
	QSPI1_MTSRB			Slave SPI data input
	ERAY0_RXDA1			Receive Channel A1
	GETH_RXD1A			Receive Data 1 MII, RMI and RGMII (RGMII can use RXD1A only)
	P11.9	O0	FAST / RGMII_Input / PU1 / VFLEX / ES	General-purpose output
	GTM_TOUT98	O1		GTM muxed output
	—	O2		Reserved
	QSPI1_MTSR	O3		Master SPI data output
	—	O4		Reserved
	MSC0_SOP	O5		Data output - direct part of the differential signal
	—	O6		Reserved
	CCU60_COUT60	O7		T12 PWM channel 60
	IOM_MON1_3			Monitor input 1
	IOM_REF1_3			Reference input 1

TC37xEXT Pin Definition and Functions LFBGA-292 Package Pinning of

Table 2-5 Port 11 Functions (cont'd)

Ball	Symbol	Ctrl.	Buffer Type	Function	
B9	P11.10	I	FAST / RGMII_Input / PU1 / VFLEX / ES	General-purpose input	
	GTM_TIM3_IN5_2			Mux input channel 5 of TIM module 3	
	GTM_TIM2_IN5_2			Mux input channel 5 of TIM module 2	
	GTM_TIM2_IN0_9			Mux input channel 0 of TIM module 2	
	CAN03_RXDD			CAN receive input node 3	
	ERAY0_RXDB1			Receive Channel B1	
	ASCLIN1_ARXE			Receive input	
	SCU_E_REQ6_3			ERU Channel 6 inputs 0 to 5 (0 is the LSB and 5 is the MSB)	
	MSC0_SDI0			Upstream asynchronous input signal	
	GETH_RXD0A			Receive Data 0 MII, RMI and RGMII (RGMII can use RXD0A only)	
	QSPI1_SLSIA			Slave select input	
	P11.10			O0	General-purpose output
	GTM_TOUT99			O1	GTM muxed output
—	O2	Reserved			
QSPI0_SLSO3	O3	Master slave select output			
QSPI1_SLSO3	O4	Master slave select output			
—	O5	Reserved			
—	O6	Reserved			
CCU60_CC62	O7	T12 PWM channel 62			
IOM_MON1_0		Monitor input 1			
IOM_REF1_4		Reference input 1			

TC37xEXT Pin Definition and Functions LFBGA-292 Package Pinning of

Table 2-5 Port 11 Functions (cont'd)

Ball	Symbol	Ctrl.	Buffer Type	Function
A8	P11.11	I	FAST / RGMII_In put / PU1 / VFLEX / ES	General-purpose input
	GTM_TIM3_IN6_2			Mux input channel 6 of TIM module 3
	GTM_TIM3_IN0_14			Mux input channel 0 of TIM module 3
	GTM_TIM2_IN6_2			Mux input channel 6 of TIM module 2
	GETH_CRSDVA			Carrier Sense / Data Valid combi-signal for RMII
	GETH_RXDVA			Receive Data Valid MII
	GETH_CRSB			Carrier Sense MII
	GETH_RCTLA			Receive Control for RGMII
	P11.11	O0	General-purpose output	
	GTM_TOUT100	O1	GTM muxed output	
	—	O2	Reserved	
	QSPIO_SLSO4	O3	Master slave select output	
	QSPI1_SLSO4	O4	Master slave select output	
	MSC0_EN0	O5	Chip Select	
	ERAY0_TXENB	O6	Transmit Enable Channel B	
	CCU60_CC61	O7	T12 PWM channel 61	
	IOM_MON1_1		Monitor input 1	
IOM_REF1_5		Reference input 1		
B8	P11.12	I	FAST / RGMII_In put / PU1 / VFLEX / ES	General-purpose input
	GTM_TIM3_IN7_2			Mux input channel 7 of TIM module 3
	GTM_TIM2_IN7_2			Mux input channel 7 of TIM module 2
	GETH_REFCLKA			Reference Clock input for RMII (50 MHz)
	GETH_TXCLKB			Transmit Clock Input for MII
	GETH_RXCLKA			Receive Clock MII
	P11.12	O0	General-purpose output	
	GTM_TOUT101	O1	GTM muxed output	
	ASCLIN1_ATX	O2	Transmit output	
	IOM_MON2_13		Monitor input 2	
	IOM_REF2_13		Reference input 2	
	GTM_CLK2	O3	CGM generated clock	
	ERAY0_TXDB	O4	Transmit Channel B	
	CAN03_TXD	O5	CAN transmit output node 3	
	IOM_MON2_8		Monitor input 2	
	IOM_REF2_8		Reference input 2	
	CCU_EXTCLK1	O6	External Clock 1	
CCU60_CC60	O7	T12 PWM channel 60		
IOM_MON1_2		Monitor input 1		
IOM_REF1_6		Reference input 1		

TC37xEXT Pin Definition and Functions LFBGA-292 Package Pinning of

Table 2-5 Port 11 Functions (cont'd)

Ball	Symbol	Ctrl.	Buffer Type	Function
E6	P11.13	I	SLOW / PU1 / VFLEX / ES	General-purpose input
	GTM_TIM4_IN6_5			Mux input channel 6 of TIM module 4
	GTM_TIM2_IN6_7			Mux input channel 6 of TIM module 2
	GETH_RXERA			Receive Error MII
	CAN13_RXDD			CAN receive input node 3
	P11.13			O0
	GTM_TOUT125	O1	GTM muxed output	
	—	O2	Reserved	
	—	O3	Reserved	
	—	O4	Reserved	
	—	O5	Reserved	
	—	O6	Reserved	
	—	O7	Reserved	
D7	P11.14	I	SLOW / PU1 / VFLEX / ES	General-purpose input
	GTM_TIM4_IN7_4			Mux input channel 7 of TIM module 4
	GTM_TIM2_IN7_8			Mux input channel 7 of TIM module 2
	GETH_CRSDVB			Carrier Sense / Data Valid combi-signal for RMII
	GETH_RXDVB			Receive Data Valid MII
	GETH_CRSA			Carrier Sense MII
	CAN20_RXDF	CAN receive input node 0		
	P11.14	O0	General-purpose output	
	GTM_TOUT126	O1	GTM muxed output	
	—	O2	Reserved	
	—	O3	Reserved	
	—	O4	Reserved	
	—	O5	Reserved	
—	O6	Reserved		
—	O7	Reserved		

TC37xEXT Pin Definition and Functions LFBGA-292 Package Pinning of

Table 2-5 Port 11 Functions (cont'd)

Ball	Symbol	Ctrl.	Buffer Type	Function
D6	P11.15	I	SLOW / PU1 / VFLEX / ES	General-purpose input
	GTM_TIM4_IN7_5			Mux input channel 7 of TIM module 4
	GTM_TIM0_IN7_8			Mux input channel 7 of TIM module 0
	GETH_COLA			Collision MII
	P11.15	O0		General-purpose output
	GTM_TOUT127	O1		GTM muxed output
	—	O2		Reserved
	—	O3		Reserved
	—	O4		Reserved
	—	O5		Reserved
	—	O6		Reserved
	—	O7		Reserved

Table 2-6 Port 12 Functions

Ball	Symbol	Ctrl.	Buffer Type	Function
E12	P12.0	I	SLOW / PU1 / VFLEX / ES	General-purpose input
	GTM_TIM4_IN0_5			Mux input channel 0 of TIM module 4
	GTM_TIM3_IN0_7			Mux input channel 0 of TIM module 3
	CAN00_RXDC			CAN receive input node 0
	GETH_RXCLKC			Receive Clock MII
	GTM_DTMA4_0			CDTM4_DTM4
	P12.0	O0		General-purpose output
	GTM_TOUT128	O1		GTM muxed output
	—	O2		Reserved
	—	O3		Reserved
	—	O4		Reserved
	—	O5		Reserved
	GETH_MDC	O6		MDIO clock
—	O7	Reserved		

TC37xEXT Pin Definition and Functions LFBGA-292 Package Pinning of

Table 2-6 Port 12 Functions (cont'd)

Ball	Symbol	Ctrl.	Buffer Type	Function
E11	P12.1	I	SLOW / PU1 / VFLEX / ES	General-purpose input
	GTM_TIM4_IN1_6			Mux input channel 1 of TIM module 4
	GTM_TIM3_IN1_6			Mux input channel 1 of TIM module 3
	GETH_MDIOC			MDIO Input
	P12.1	O0	General-purpose output	
	GTM_TOUT129	O1	GTM muxed output	
	ASCLIN3_ASLSO	O2	Slave select signal output	
	—	O3	Reserved	
	—	O4	Reserved	
	CAN00_TXD	O5	CAN transmit output node 0	
	IOM_MON2_5		Monitor input 2	
	IOM_REF2_5		Reference input 2	
	—	O6	Reserved	
	—	O7	Reserved	
	GETH_MDIO	O	MDIO Output	

Table 2-7 Port 13 Functions

Ball	Symbol	Ctrl.	Buffer Type	Function
B12	P13.0	I	LVDS_TX / FAST / PU1 / VEXT / ES6	General-purpose input
	GTM_TIM3_IN5_3			Mux input channel 5 of TIM module 3
	GTM_TIM2_IN5_3			Mux input channel 5 of TIM module 2
	ASCLIN10_ARXC			Receive input
	P13.0	O0	General-purpose output	
	GTM_TOUT91	O1	GTM muxed output	
	ASCLIN10_ATX	O2	Transmit output	
	QSPI2_SCLKN	O3	Master SPI clock output (LVDS N line)	
	MSC0_EN1	O4	Chip Select	
	MSC0_FCLN	O5	Shift-clock inverted part of the differential signal	
	—	O6	Reserved	
	CAN10_TXD	O7	CAN transmit output node 0	

TC37xEXT Pin Definition and Functions LFBGA-292 Package Pinning of

Table 2-7 Port 13 Functions (cont'd)

Ball	Symbol	Ctrl.	Buffer Type	Function
A12	P13.1	I	LVDS_TX / FAST / PU1 / VEXT / ES6	General-purpose input
	GTM_TIM3_IN6_3			Mux input channel 6 of TIM module 3
	GTM_TIM2_IN6_3			Mux input channel 6 of TIM module 2
	I2C0_SCLB			Serial Clock Input 1
	CAN10_RXDD			CAN receive input node 0
	ASCLIN10_ARXD			Receive input
	P13.1			O0
	GTM_TOUT92	O1	GTM muxed output	
	—	O2	Reserved	
	QSPI2_SCLKP	O3	Master SPI clock output (LVDS P line)	
	—	O4	Reserved	
	MSC0_FCLP	O5	Shift-clock direct part of the differential signal	
	I2C0_SCL	O6	Serial Clock Output	
	—	O7	Reserved	
B11	P13.2	I	LVDS_TX / FAST / PU1 / VEXT / ES6	General-purpose input
	GTM_TIM3_IN7_3			Mux input channel 7 of TIM module 3
	GTM_TIM2_IN7_3			Mux input channel 7 of TIM module 2
	GPT120_CAPINA			Trigger input to capture value of timer T5 into CAPREL register
	I2C0_SDAB			Serial Data Input 1
	P13.2	O0		General-purpose output
	GTM_TOUT93	O1		GTM muxed output
	ASCLIN10_ASCLK	O2		Shift clock output
	QSPI2_MTSRN	O3		Master SPI data output (LVDS N line)
	MSC0_FCLP	O4		Shift-clock direct part of the differential signal
	MSC0_SON	O5		Data output - inverted part of the differential signal
	I2C0_SDA	O6		Serial Data Output
	—	O7		Reserved

TC37xEXT Pin Definition and Functions LFBGA-292 Package Pinning of

Table 2-7 Port 13 Functions (cont'd)

Ball	Symbol	Ctrl.	Buffer Type	Function
A11	P13.3	I	LVDS_TX / FAST / PU1 / VEXT / ES6	General-purpose input
	GTM_TIM3_IN0_3			Mux input channel 0 of TIM module 3
	GTM_TIM2_IN0_3			Mux input channel 0 of TIM module 2
	P13.3	O0		General-purpose output
	GTM_TOUT94	O1		GTM muxed output
	ASCLIN10_ASLSO	O2		Slave select signal output
	QSPI2_MTSRP	O3		Master SPI data output (LVDS P line)
	—	O4		Reserved
	MSC0_SOP	O5		Data output - direct part of the differential signal
	—	O6		Reserved
	—	O7		Reserved

Table 2-8 Port 14 Functions

Ball	Symbol	Ctrl.	Buffer Type	Function
B16	P14.0	I	FAST / PU1 / VEXT / ES2	General-purpose input
	GTM_TIM1_IN3_5			Mux input channel 3 of TIM module 1
	GTM_TIM0_IN3_5			Mux input channel 3 of TIM module 0
	P14.0	O0		General-purpose output
	GTM_TOUT80	O1		GTM muxed output
	ASCLIN0_ATX	O2		Transmit output
	IOM_MON2_12			Monitor input 2
	IOM_REF2_12			Reference input 2
	ERAY0_TXDA	O3		Transmit Channel A
	ERAY0_TXDB	O4		Transmit Channel B
	CAN01_TXD	O5		CAN transmit output node 1
	IOM_MON2_6			Monitor input 2
	IOM_REF2_6			Reference input 2
	ASCLIN0_ASCLK	O6		Shift clock output
	CCU60_COUT62	O7		T12 PWM channel 62
	IOM_MON1_5			Monitor input 1
	IOM_REF1_1			Reference input 1

TC37xEXT Pin Definition and Functions LFBGA-292 Package Pinning of

Table 2-8 Port 14 Functions (cont'd)

Ball	Symbol	Ctrl.	Buffer Type	Function
A15	P14.1	I	FAST / PU1 / VEXT / ES2	General-purpose input
	GTM_TIM1_IN4_3			Mux input channel 4 of TIM module 1
	GTM_TIM0_IN4_3			Mux input channel 4 of TIM module 0
	ERAY0_RXDA3			Receive Channel A3
	ASCLIN0_ARXA			Receive input
	ERAY0_RXDB3			Receive Channel B3
	CAN01_RXDB			CAN receive input node 1
	SCU_E_REQ3_1			ERU Channel 3 inputs 0 to 5 (0 is the LSB and 5 is the MSB)
	PMS_PINAWKP			PINA (P14.1) pin input
	P14.1			O0
	GTM_TOUT81	O1	GTM muxed output	
	ASCLIN0_ATX	O2	Transmit output	
	IOM_MON2_12		Monitor input 2	
	IOM_REF2_12		Reference input 2	
	—	O3	Reserved	
	—	O4	Reserved	
	—	O5	Reserved	
	—	O6	Reserved	
	CCU60_COUT63	O7	T13 PWM channel 63	
	IOM_MON1_6		Monitor input 1	
IOM_REF1_0	Reference input 1			
E13	P14.2	I	SLOW / PU2 / VEXT / ES	General-purpose input
	GTM_TIM1_IN5_3			Mux input channel 5 of TIM module 1
	GTM_TIM0_IN5_3			Mux input channel 5 of TIM module 0
	PMS_HWCFG2IN			HWCFG2 pin input
	P14.2	O0	General-purpose output	
	GTM_TOUT82	O1	GTM muxed output	
	ASCLIN2_ATX	O2	Transmit output	
	IOM_MON2_14		Monitor input 2	
	IOM_REF2_14		Reference input 2	
	QSPI2_SLSO1	O3	Master slave select output	
	—	O4	Reserved	
	—	O5	Reserved	
	ASCLIN2_ASCLK	O6	Shift clock output	
	—	O7	Reserved	

TC37xEXT Pin Definition and Functions LFBGA-292 Package Pinning of

Table 2-8 Port 14 Functions (cont'd)

Ball	Symbol	Ctrl.	Buffer Type	Function
B14	P14.3	I	SLOW / PU2 / VEXT / ES	General-purpose input
	GTM_TIM1_IN6_3			Mux input channel 6 of TIM module 1
	GTM_TIM0_IN6_3			Mux input channel 6 of TIM module 0
	PMS_HWCFG3IN			HWCFG3 pin input
	ASCLIN2_ARXA			Receive input
	MSC0_SDI2			Upstream assynchronous input signal
	SCU_E_REQ1_0			ERU Channel 1 inputs 0 to 5 (0 is the LSB and 5 is the MSB)
	P14.3	O0	General-purpose output	
	GTM_TOUT83	O1	GTM muxed output	
	ASCLIN2_ATX	O2	Transmit output	
	IOM_MON2_14		Monitor input 2	
	IOM_REF2_14		Reference input 2	
	QSPI2_SLSO3	O3	Master slave select output	
	ASCLIN1_ASLSO	O4	Slave select signal output	
	ASCLIN3_ASLSO	O5	Slave select signal output	
	—	O6	Reserved	
—	O7	Reserved		
B15	P14.4	I	SLOW / PU2 / VEXT / ES	General-purpose input
	GTM_TIM1_IN7_2			Mux input channel 7 of TIM module 1
	GTM_TIM0_IN7_2			Mux input channel 7 of TIM module 0
	PMS_HWCFG6IN			HWCFG6 pin input
	GTM_DTMT0_0			CDTM0_DTM0
	P14.4	O0	General-purpose output	
	GTM_TOUT84	O1	GTM muxed output	
	—	O2	Reserved	
	—	O3	Reserved	
	—	O4	Reserved	
	—	O5	Reserved	
	GETH_PPS	O6	Pulse Per Second	
	—	O7	Reserved	

TC37xEXT Pin Definition and Functions LFBGA-292 Package Pinning of

Table 2-8 Port 14 Functions (cont'd)

Ball	Symbol	Ctrl.	Buffer Type	Function
A14	P14.5	I	FAST / PU2 / VEXT / ES	General-purpose input
	GTM_TIM1_IN0_4			Mux input channel 0 of TIM module 1
	GTM_TIM0_IN0_4			Mux input channel 0 of TIM module 0
	PMS_HWCFG1IN			HWCFG1 pin input
	GTM_DTMA2_0			CDTM2_DTM4
	P14.5			O0
	GTM_TOUT85	O1	GTM muxed output	
	—	O2	Reserved	
	—	O3	Reserved	
	—	O4	Reserved	
	—	O5	Reserved	
	ERAY0_TXDB	O6	Transmit Channel B	
	—	O7	Reserved	
B13	P14.6	I	FAST / PU1 / VEXT / ES	General-purpose input
	GTM_TIM1_IN1_4			Mux input channel 1 of TIM module 1
	GTM_TIM0_IN1_4			Mux input channel 1 of TIM module 0
	P14.6	O0	General-purpose output	
	GTM_TOUT86	O1	GTM muxed output	
	—	O2	Reserved	
	QSPI2_SLSO2	O3	Master slave select output	
	CAN13_TXD	O4	CAN transmit output node 3	
	—	O5	Reserved	
	ERAY0_TXENB	O6	Transmit Enable Channel B	
	—	O7	Reserved	

TC37xEXT Pin Definition and Functions LFBGA-292 Package Pinning of

Table 2-8 Port 14 Functions (cont'd)

Ball	Symbol	Ctrl.	Buffer Type	Function
D13	P14.7	I	SLOW / PU1 / VEXT / ES	General-purpose input
	GTM_TIM4_IN7_10			Mux input channel 7 of TIM module 4
	GTM_TIM1_IN0_5			Mux input channel 0 of TIM module 1
	GTM_TIM0_IN0_5			Mux input channel 0 of TIM module 0
	ERAY0_RXDB0			Receive Channel B0
	CAN10_RXDB			CAN receive input node 0
	CAN13_RXDA			CAN receive input node 3
	ASCLIN9_ARXC			Receive input
	P14.7	O0	General-purpose output	
	GTM_TOUT87	O1	GTM muxed output	
	ASCLIN0_ARTS	O2	Ready to send output	
	QSPI2_SLSO4	O3	Master slave select output	
	ASCLIN9_ATX	O4	Transmit output	
	—	O5	Reserved	
—	O6	Reserved		
—	O7	Reserved		
A13	P14.8	I	SLOW / PU1 / VEXT / ES	General-purpose input
	GTM_TIM3_IN2_3			Mux input channel 2 of TIM module 3
	GTM_TIM2_IN2_3			Mux input channel 2 of TIM module 2
	ERAY0_RXDA0			Receive Channel A0
	CAN02_RXDD			CAN receive input node 2
	ASCLIN1_ARXD			Receive input
	P14.8	O0	General-purpose output	
	GTM_TOUT88	O1	GTM muxed output	
	ASCLIN5_ASLSO	O2	Slave select signal output	
	ASCLIN7_ASLSO	O3	Slave select signal output	
	—	O4	Reserved	
	—	O5	Reserved	
	—	O6	Reserved	
	—	O7	Reserved	

TC37xEXT Pin Definition and Functions LFBGA-292 Package Pinning of

Table 2-8 Port 14 Functions (cont'd)

Ball	Symbol	Ctrl.	Buffer Type	Function
D12	P14.9	I	LVDS_R X/FAST/ PU1/ VEXT/ ES	General-purpose input
	GTM_TIM3_IN3_3			Mux input channel 3 of TIM module 3
	GTM_TIM2_IN3_3			Mux input channel 3 of TIM module 2
	ASCLIN0_ACTSA			Clear to send input
	QSPI2_MRSTFN			Master SPI data input (LVDS N line)
	ASCLIN9_ARXD			Receive input
	P14.9			O0
	GTM_TOUT89	O1	GTM muxed output	
	CAN23_TXD	O2	CAN transmit output node 3	
	MSC0_EN1	O3	Chip Select	
	CAN10_TXD	O4	CAN transmit output node 0	
	ERAY0_TXENB	O5	Transmit Enable Channel B	
	ERAY0_TXENA	O6	Transmit Enable Channel A	
	—	O7	Reserved	
D11	P14.10	I	LVDS_R X/FAST/ PU1/ VEXT/ ES	General-purpose input
	GTM_TIM3_IN4_3			Mux input channel 4 of TIM module 3
	GTM_TIM2_IN4_3			Mux input channel 4 of TIM module 2
	CAN23_RXDA			CAN receive input node 3
	QSPI2_MRSTFP			Master SPI data input (LVDS P line)
	P14.10	O0	General-purpose output	
	GTM_TOUT90	O1	GTM muxed output	
	—	O2	Reserved	
	MSC0_EN0	O3	Chip Select	
	ASCLIN1_ATX	O4	Transmit output	
	IOM_MON2_13	O5	Monitor input 2	
	IOM_REF2_13		Reference input 2	
	CAN02_TXD		CAN transmit output node 2	
	IOM_MON2_7	O6	Monitor input 2	
	IOM_REF2_7		Reference input 2	
	ERAY0_TXDA	O6	Transmit Channel A	
—	O7	Reserved		

TC37xEXT Pin Definition and Functions LFBGA-292 Package Pinning of

Table 2-9 Port 15 Functions

Ball	Symbol	Ctrl.	Buffer Type	Function	
B20	P15.0	I	FAST / PU1 / VEXT / ES	General-purpose input	
	GTM_TIM3_IN3_4			Mux input channel 3 of TIM module 3	
	GTM_TIM2_IN3_4			Mux input channel 3 of TIM module 2	
	SDMMC0_DAT7_IN			read data in	
	P15.0			O0	General-purpose output
	GTM_TOUT71			O1	GTM muxed output
	ASCLIN1_ATX			O2	Transmit output
	IOM_MON2_13				Monitor input 2
	IOM_REF2_13				Reference input 2
	QSPI0_SLSO13			O3	Master slave select output
	—			O4	Reserved
	CAN02_TXD			O5	CAN transmit output node 2
	IOM_MON2_7			O6	Monitor input 2
	IOM_REF2_7				Reference input 2
	ASCLIN1_ASCLK				Shift clock output
—	O7	Reserved			
SDMMC0_DAT7	O	write data out			
A18	P15.1	I	FAST / PU1 / VEXT / ES	General-purpose input	
	GTM_TIM3_IN4_4			Mux input channel 4 of TIM module 3	
	GTM_TIM2_IN4_4			Mux input channel 4 of TIM module 2	
	CAN02_RXDA			CAN receive input node 2	
	ASCLIN1_ARXA			Receive input	
	QSPI2_SLSIB			Slave select input	
	SCU_E_REQ7_2			ERU Channel 7 inputs 0 to 5 (0 is the LSB and 5 is the MSB)	
	P15.1			O0	General-purpose output
	GTM_TOUT72			O1	GTM muxed output
	ASCLIN1_ATX			O2	Transmit output
	IOM_MON2_13				Monitor input 2
	IOM_REF2_13				Reference input 2
	QSPI2_SLSO5			O3	Master slave select output
	—			O4	Reserved
	—			O5	Reserved
—	O6	Reserved			
SDMMC0_CLK	O7	card clock			

TC37xEXT Pin Definition and Functions LFBGA-292 Package Pinning of

Table 2-9 Port 15 Functions (cont'd)

Ball	Symbol	Ctrl.	Buffer Type	Function
C19	P15.2	I	FAST / PU1 / VEXT / ES	General-purpose input
	GTM_TIM3_IN5_4			Mux input channel 5 of TIM module 3
	GTM_TIM2_IN5_4			Mux input channel 5 of TIM module 2
	QSPI2_SLSIA			Slave select input
	SENT_SENT10D			Receive input channel 10
	QSPI2_MRSTE			Master SPI data input
	P15.2	O0		General-purpose output
	GTM_TOUT73	O1		GTM muxed output
	ASCLIN0_ATX	O2		Transmit output
	IOM_MON2_12			Monitor input 2
	IOM_REF2_12			Reference input 2
	QSPI2_SLSO0	O3		Master slave select output
	—	O4		Reserved
	CAN01_TXD	O5		CAN transmit output node 1
	IOM_MON2_6	O6		Monitor input 2
	IOM_REF2_6			Reference input 2
	ASCLIN0_ASCLK			Shift clock output
	—	O7		Reserved
	B17	P15.3		I
GTM_TIM3_IN6_4		Mux input channel 6 of TIM module 3		
GTM_TIM2_IN6_4		Mux input channel 6 of TIM module 2		
CAN01_RXDA		CAN receive input node 1		
ASCLIN0_ARXB		Receive input		
QSPI2_SCLKA		Slave SPI clock inputs		
SDMMC0_CMD_IN		command in		
P15.3		O0	General-purpose output	
GTM_TOUT74		O1	GTM muxed output	
ASCLIN0_ATX		O2	Transmit output	
IOM_MON2_12			Monitor input 2	
IOM_REF2_12			Reference input 2	
QSPI2_SCLK		O3	Master SPI clock output	
—		O4	Reserved	
MSC0_EN1		O5	Chip Select	
—		O6	Reserved	
—		O7	Reserved	
SDMMC0_CMD		O	command out	

TC37xEXT Pin Definition and Functions LFBGA-292 Package Pinning of

Table 2-9 Port 15 Functions (cont'd)

Ball	Symbol	Ctrl.	Buffer Type	Function
A17	P15.4	I	FAST / PU1 / VEXT / ES	General-purpose input
	GTM_TIM3_IN7_4			Mux input channel 7 of TIM module 3
	GTM_TIM2_IN7_4			Mux input channel 7 of TIM module 2
	I2C0_SCLC			Serial Clock Input 2
	QSPI2_MRSTA			Master SPI data input
	SCU_E_REQ0_0			ERU Channel 0 inputs 0 to 5 (0 is the LSB and 5 is the MSB)
	SENT_SENT11D			Receive input channel 11
	P15.4			O0
	GTM_TOUT75	O1	GTM muxed output	
	ASCLIN1_ATX	O2	Transmit output	
	IOM_MON2_13		Monitor input 2	
	IOM_REF2_13		Reference input 2	
	QSPI2_MRST	O3	Slave SPI data output	
	IOM_MON2_2		Monitor input 2	
	IOM_REF2_2		Reference input 2	
	—	O4	Reserved	
	—	O5	Reserved	
	I2C0_SCL	O6	Serial Clock Output	
	CCU60_CC62	O7	T12 PWM channel 62	
	IOM_MON1_0		Monitor input 1	
IOM_REF1_4	Reference input 1			

TC37xEXT Pin Definition and Functions LFBGA-292 Package Pinning of

Table 2-9 Port 15 Functions (cont'd)

Ball	Symbol	Ctrl.	Buffer Type	Function
E14	P15.5	I	FAST / PU1 / VEXT / ES	General-purpose input
	GTM_TIM3_IN0_4			Mux input channel 0 of TIM module 3
	GTM_TIM2_IN0_4			Mux input channel 0 of TIM module 2
	ASCLIN1_ARXB			Receive input
	I2C0_SDAC			Serial Data Input 2
	QSPI2_MTSRA			Slave SPI data input
	SCU_E_REQ4_3			ERU Channel 4 inputs 0 to 5 (0 is the LSB and 5 is the MSB)
	P15.5	O0	General-purpose output	
	GTM_TOUT76	O1	GTM muxed output	
	ASCLIN1_ATX	O2	Transmit output	
	IOM_MON2_13		Monitor input 2	
	IOM_REF2_13		Reference input 2	
	QSPI2_MTSR	O3	Master SPI data output	
	—	O4	Reserved	
	MSC0_EN0	O5	Chip Select	
	I2C0_SDA	O6	Serial Data Output	
	CCU60_CC61	O7	T12 PWM channel 61	
IOM_MON1_1	Monitor input 1			
IOM_REF1_5	Reference input 1			
A16	P15.6	I	FAST / PU1 / VEXT / ES	General-purpose input
	GTM_TIM2_IN2_14			Mux input channel 2 of TIM module 2
	GTM_TIM1_IN0_6			Mux input channel 0 of TIM module 1
	GTM_TIM0_IN0_6			Mux input channel 0 of TIM module 0
	QSPI2_MTSRB			Slave SPI data input
	P15.6	O0	General-purpose output	
	GTM_TOUT77	O1	GTM muxed output	
	ASCLIN3_ATX	O2	Transmit output	
	IOM_MON2_15		Monitor input 2	
	IOM_REF2_15		Reference input 2	
	QSPI2_MTSR	O3	Master SPI data output	
	—	O4	Reserved	
	QSPI2_SCLK	O5	Master SPI clock output	
	ASCLIN3_ASCLK	O6	Shift clock output	
	CCU60_CC60	O7	T12 PWM channel 60	
IOM_MON1_2	Monitor input 1			
IOM_REF1_6	Reference input 1			

TC37xEXT Pin Definition and Functions LFBGA-292 Package Pinning of

Table 2-9 Port 15 Functions (cont'd)

Ball	Symbol	Ctrl.	Buffer Type	Function
D15	P15.7	I	FAST / PU1 / VEXT / ES	General-purpose input
	GTM_TIM1_IN1_5			Mux input channel 1 of TIM module 1
	GTM_TIM0_IN1_5			Mux input channel 1 of TIM module 0
	ASCLIN3_ARXA			Receive input
	QSPI2_MRSTB			Master SPI data input
	P15.7	O0	General-purpose output	
	GTM_TOUT78	O1	GTM muxed output	
	ASCLIN3_ATX	O2	Transmit output	
	IOM_MON2_15	O3	Monitor input 2	
	IOM_REF2_15		Reference input 2	
	QSPI2_MRST		Slave SPI data output	
	IOM_MON2_2	Monitor input 2		
	IOM_REF2_2	Reference input 2		
	—	O4	Reserved	
	—	O5	Reserved	
	—	O6	Reserved	
	CCU60_COUT60	O7	T12 PWM channel 60	
IOM_MON1_3	O7	Monitor input 1		
IOM_REF1_3		Reference input 1		
D14	P15.8	I	FAST / PU1 / VEXT / ES	General-purpose input
	GTM_TIM1_IN2_5			Mux input channel 2 of TIM module 1
	GTM_TIM0_IN2_5			Mux input channel 2 of TIM module 0
	QSPI2_SCLKB			Slave SPI clock inputs
	SCU_E_REQ5_0			ERU Channel 5 inputs 0 to 5 (0 is the LSB and 5 is the MSB)
	P15.8	O0	General-purpose output	
	GTM_TOUT79	O1	GTM muxed output	
	—	O2	Reserved	
	QSPI2_SCLK	O3	Master SPI clock output	
	—	O4	Reserved	
	—	O5	Reserved	
	ASCLIN3_ASCLK	O6	Shift clock output	
	CCU60_COUT61	O7	T12 PWM channel 61	
	IOM_MON1_4	O7	Monitor input 1	
IOM_REF1_2	Reference input 1			

TC37xEXT Pin Definition and Functions LFBGA-292 Package Pinning of

Table 2-10 Port 20 Functions

Ball	Symbol	Ctrl.	Buffer Type	Function
H20	P20.0	I	FAST / PU1 / VEXT / ES	General-purpose input
	GTM_TIM1_IN6_7			Mux input channel 6 of TIM module 1
	GTM_TIM1_IN4_9			Mux input channel 4 of TIM module 1
	GTM_TIM0_IN6_7			Mux input channel 6 of TIM module 0
	CAN03_RXDC			CAN receive input node 3
	CCU_PAD_SYSCLK			Sysclk input
	CAN21_RXDC			CAN receive input node 1
	CBS_TGI0			Trigger input
	SCU_E_REQ6_0			ERU Channel 6 inputs 0 to 5 (0 is the LSB and 5 is the MSB)
	GPT120_T6EUDA			Count direction control input of core timer T6
	P20.0	O0	General-purpose output	
	GTM_TOUT59	O1	GTM muxed output	
	ASCLIN3_ATX	O2	Transmit output	
	IOM_MON2_15		Monitor input 2	
	IOM_REF2_15		Reference input 2	
	ASCLIN3_ASCLK	O3	Shift clock output	
	—	O4	Reserved	
	HSCT0_SYSCLK_OUT	O5	sys clock output	
	—	O6	Reserved	
	—	O7	Reserved	
CBS_TGO0	O	Trigger output		
G19	P20.1	I	SLOW / PU1 / VEXT / ES	General-purpose input
	GTM_TIM4_IN4_11			Mux input channel 4 of TIM module 4
	GTM_TIM3_IN3_5			Mux input channel 3 of TIM module 3
	GTM_TIM2_IN3_5			Mux input channel 3 of TIM module 2
	CBS_TGI1			Trigger input
	GTM_DTMA1_1			CDTM1_DTM4
	P20.1	O0	General-purpose output	
	GTM_TOUT60	O1	GTM muxed output	
	—	O2	Reserved	
	—	O3	Reserved	
	—	O4	Reserved	
	—	O5	Reserved	
	—	O6	Reserved	
	—	O7	Reserved	
CBS_TGO1	O	Trigger output		

TC37xEXT Pin Definition and Functions LFBGA-292 Package Pinning of

Table 2-10 Port 20 Functions (cont'd)

Ball	Symbol	Ctrl.	Buffer Type	Function
H19	P20.2	I	S / PU / VEXT	General-purpose input This pin is latched at power on reset release to enter test mode.
	TESTMODE			Testmode Enable Input
G20	P20.3	I	SLOW / PU1 / VEXT / ES	General-purpose input
	GTM_TIM4_IN5_11			Mux input channel 5 of TIM module 4
	GTM_TIM3_IN4_5			Mux input channel 4 of TIM module 3
	GTM_TIM2_IN4_5			Mux input channel 4 of TIM module 2
	ASCLIN3_ARXC			Receive input
	GPT120_T6INA			Trigger/gate input of core timer T6
	P20.3	O0		General-purpose output
	GTM_TOUT61	O1		GTM muxed output
	ASCLIN3_ATX	O2		Transmit output
	IOM_MON2_15			Monitor input 2
	IOM_REF2_15			Reference input 2
	QSPI0_SLSO9	O3		Master slave select output
	QSPI2_SLSO9	O4		Master slave select output
	CAN03_TXD	O5		CAN transmit output node 3
	IOM_MON2_8			Monitor input 2
	IOM_REF2_8			Reference input 2
	CAN21_TXD	O6		CAN transmit output node 1
—	O7	Reserved		
F17	P20.6	I	SLOW / PU1 / VEXT / ES	General-purpose input
	GTM_TIM3_IN6_5			Mux input channel 6 of TIM module 3
	GTM_TIM2_IN6_5			Mux input channel 6 of TIM module 2
	CAN12_RXDA			CAN receive input node 2
	ASCLIN9_ARXE			Receive input
	P20.6	O0		General-purpose output
	GTM_TOUT62	O1		GTM muxed output
	ASCLIN1_ARTS	O2		Ready to send output
	QSPI0_SLSO8	O3		Master slave select output
	QSPI2_SLSO8	O4		Master slave select output
	—	O5		Reserved
	—	O6		Reserved
	—	O7		Reserved

TC37xEXT Pin Definition and Functions LFBGA-292 Package Pinning of

Table 2-10 Port 20 Functions (cont'd)

Ball	Symbol	Ctrl.	Buffer Type	Function
F19	P20.7	I	FAST / PU1 / VEXT / ES	General-purpose input
	GTM_TIM3_IN7_5			Mux input channel 7 of TIM module 3
	GTM_TIM2_IN7_5			Mux input channel 7 of TIM module 2
	GTM_TIM1_IN5_8			Mux input channel 5 of TIM module 1
	CAN00_RXDB			CAN receive input node 0
	ASCLIN1_ACTSA			Clear to send input
	ASCLIN9_ARXF			Receive input
	SDMMC0_DAT0_IN			read data in
	P20.7			O0
	GTM_TOUT63	O1	GTM muxed output	
	ASCLIN9_ATX	O2	Transmit output	
	—	O3	Reserved	
	—	O4	Reserved	
	CAN12_TXD	O5	CAN transmit output node 2	
	—	O6	Reserved	
	CCU61_COUT63	O7	T13 PWM channel 63	
	IOM_MON1_7	O	Monitor input 1	
	IOM_REF1_7		Reference input 1	
	SDMMC0_DAT0	O	write data out	
F20	P20.8	I	FAST / PU1 / VEXT / ES	General-purpose input
	GTM_TIM1_IN7_3			Mux input channel 7 of TIM module 1
	GTM_TIM0_IN7_3			Mux input channel 7 of TIM module 0
	SDMMC0_DAT1_IN			read data in
	P20.8	O0	General-purpose output	
	GTM_TOUT64	O1	GTM muxed output	
	ASCLIN1_ASLSO	O2	Slave select signal output	
	QSPI0_SLSO0	O3	Master slave select output	
	QSPI1_SLSO0	O4	Master slave select output	
	CAN00_TXD	O5	CAN transmit output node 0	
	IOM_MON2_5	O	Monitor input 2	
	IOM_REF2_5		Reference input 2	
	—	O6	Reserved	
	CCU61_CC60	O7	T12 PWM channel 60	
	IOM_MON1_8	O	Monitor input 1	
	IOM_REF1_13		Reference input 1	
	SDMMC0_DAT1	O	write data out	

TC37xEXT Pin Definition and Functions LFBGA-292 Package Pinning of

Table 2-10 Port 20 Functions (cont'd)

Ball	Symbol	Ctrl.	Buffer Type	Function
E17	P20.9	I	FAST / PU1 / VEXT / ES	General-purpose input
	GTM_TIM3_IN5_5			Mux input channel 5 of TIM module 3
	GTM_TIM2_IN5_5			Mux input channel 5 of TIM module 2
	CAN03_RXDE			CAN receive input node 3
	ASCLIN1_ARXC			Receive input
	QSPI0_SLSIB			Slave select input
	SCU_E_REQ7_0			ERU Channel 7 inputs 0 to 5 (0 is the LSB and 5 is the MSB)
	P20.9	O0	General-purpose output	
	GTM_TOUT65	O1	GTM muxed output	
	—	O2	Reserved	
	QSPI0_SLSO1	O3	Master slave select output	
	QSPI1_SLSO1	O4	Master slave select output	
	—	O5	Reserved	
	—	O6	Reserved	
	CCU61_CC61	O7	T12 PWM channel 61	
	IOM_MON1_9		Monitor input 1	
IOM_REF1_12		Reference input 1		
E19	P20.10	I	FAST / PU1 / VEXT / ES	General-purpose input
	GTM_TIM3_IN6_6			Mux input channel 6 of TIM module 3
	GTM_TIM2_IN6_6			Mux input channel 6 of TIM module 2
	SDMMC0_DAT2_IN			read data in
	P20.10	O0	General-purpose output	
	GTM_TOUT66	O1	GTM muxed output	
	ASCLIN1_ATX	O2	Transmit output	
	IOM_MON2_13		Monitor input 2	
	IOM_REF2_13		Reference input 2	
	QSPI0_SLSO6	O3	Master slave select output	
	QSPI2_SLSO7	O4	Master slave select output	
	CAN03_TXD	O5	CAN transmit output node 3	
	IOM_MON2_8		Monitor input 2	
	IOM_REF2_8		Reference input 2	
	ASCLIN1_ASCLK	O6	Shift clock output	
	CCU61_CC62	O7	T12 PWM channel 62	
	IOM_MON1_10		Monitor input 1	
	IOM_REF1_11		Reference input 1	
SDMMC0_DAT2	O	write data out		

TC37xEXT Pin Definition and Functions LFBGA-292 Package Pinning of

Table 2-10 Port 20 Functions (cont'd)

Ball	Symbol	Ctrl.	Buffer Type	Function
E20	P20.11	I	FAST / PU1 / VEXT / ES	General-purpose input
	GTM_TIM3_IN7_6			Mux input channel 7 of TIM module 3
	GTM_TIM2_IN7_6			Mux input channel 7 of TIM module 2
	QSPIO_SCLKA			Slave SPI clock inputs
	SDMMC0_DAT3_IN			read data in
	P20.11	O0		General-purpose output
	GTM_TOUT67	O1		GTM muxed output
	—	O2		Reserved
	QSPIO_SCLK	O3		Master SPI clock output
	—	O4		Reserved
	—	O5		Reserved
	—	O6		Reserved
	CCU61_COUT60	O7		T12 PWM channel 60
	IOM_MON1_11			Monitor input 1
	IOM_REF1_10			Reference input 1
SDMMC0_DAT3	O	write data out		
D19	P20.12	I	FAST / PU1 / VEXT / ES	General-purpose input
	GTM_TIM3_IN0_5			Mux input channel 0 of TIM module 3
	GTM_TIM2_IN0_5			Mux input channel 0 of TIM module 2
	QSPIO_MRSTA			Master SPI data input
	SDMMC0_DAT4_IN			read data in
	IOM_PIN_13	GPIO pad input to FPC		
	P20.12	O0		General-purpose output
	GTM_TOUT68	O1		GTM muxed output
	IOM_MON0_13	O2		Monitor input 0
	—			Reserved
	QSPIO_MRST			Slave SPI data output
	IOM_MON2_0	O3		Monitor input 2
	IOM_REF2_0			Reference input 2
	QSPIO_MTSR	O4		Master SPI data output
	—	O5		Reserved
	—	O6		Reserved
	CCU61_COUT61	O7		T12 PWM channel 61
	IOM_MON1_12			Monitor input 1
IOM_REF1_9	Reference input 1			
SDMMC0_DAT4	O	write data out		

TC37xEXT Pin Definition and Functions LFBGA-292 Package Pinning of

Table 2-10 Port 20 Functions (cont'd)

Ball	Symbol	Ctrl.	Buffer Type	Function
D20	P20.13	I	FAST / PU1 / VEXT / ES	General-purpose input
	GTM_TIM3_IN1_4			Mux input channel 1 of TIM module 3
	GTM_TIM2_IN1_4			Mux input channel 1 of TIM module 2
	QSPIO_SLSIA			Slave select input
	SDMMC0_DAT5_IN			read data in
	IOM_PIN_14			GPIO pad input to FPC
	P20.13			O0
	GTM_TOUT69	O1	GTM muxed output	
	IOM_MON0_14	O2	Monitor input 0	
	—		Reserved	
	QSPIO_SLSO2		Master slave select output	
	QSPIO_SLSO2	O4	Master slave select output	
	QSPIO_SCLK	O5	Master SPI clock output	
	—	O6	Reserved	
	CCU61_COUT62	O7	T12 PWM channel 62	
	IOM_MON1_13	O	Monitor input 1	
	IOM_REF1_8		Reference input 1	
	SDMMC0_DAT5		write data out	
	C20	P20.14	I	FAST / PU1 / VEXT / ES
GTM_TIM3_IN2_4		Mux input channel 2 of TIM module 3		
GTM_TIM2_IN2_4		Mux input channel 2 of TIM module 2		
QSPIO_MTSRA		Slave SPI data input		
SDMMC0_DAT6_IN		read data in		
IOM_PIN_15		GPIO pad input to FPC		
DMU_FDEST		Enter destructive debug mode		
P20.14		O0	General-purpose output	
GTM_TOUT70		O1	GTM muxed output	
IOM_MON0_15		O2	Monitor input 0	
—			Reserved	
QSPIO_MTSR			Master SPI data output	
—		O4	Reserved	
—		O5	Reserved	
—		O6	Reserved	
—		O7	Reserved	
SDMMC0_DAT6		O	write data out	

TC37xEXT Pin Definition and Functions LFBGA-292 Package Pinning of

Table 2-11 Port 21 Functions

Ball	Symbol	Ctrl.	Buffer Type	Function
K17	P21.0	I	LVDS_R X/FAST/ PU1/ VEXT/ ES	General-purpose input
	GTM_TIM4_IN0_11			Mux input channel 0 of TIM module 4
	GTM_TIM3_IN4_6			Mux input channel 4 of TIM module 3
	GTM_TIM2_IN4_6			Mux input channel 4 of TIM module 2
	QSPI4_MRSTDN			Master SPI data input (LVDS N line)
	ASCLIN11_ARXC			Receive input
	P21.0	O0		General-purpose output
	GTM_TOUT51	O1		GTM muxed output
	ASCLIN11_ATX	O2		Transmit output
	—	O3		Reserved
	—	O4		Reserved
	—	O5		Reserved
	GETH1_PPS	O6		Pulse Per Second
	—	O7		Reserved
HSM_HSM1	O	Pin Output Value		
J17	P21.1	I	LVDS_R X/FAST/ PU1/ VEXT/ ES	General-purpose input
	GTM_TIM4_IN1_13			Mux input channel 1 of TIM module 4
	GTM_TIM3_IN5_6			Mux input channel 5 of TIM module 3
	GTM_TIM2_IN5_6			Mux input channel 5 of TIM module 2
	QSPI4_MRSTDP			Master SPI data input (LVDS P line)
	ASCLIN11_ARXD			Receive input
	GTM_DTMA4_1			CDTM4_DTM4
	P21.1	O0		General-purpose output
	GTM_TOUT52	O1		GTM muxed output
	—	O2		Reserved
	—	O3		Reserved
	—	O4		Reserved
	—	O5		Reserved
	—	O6		Reserved
—	O7	Reserved		
HSM_HSM2	O	Pin Output Value		

TC37xEXT Pin Definition and Functions LFBGA-292 Package Pinning of

Table 2-11 Port 21 Functions (cont'd)

Ball	Symbol	Ctrl.	Buffer Type	Function
K19	P21.2	I	LVDS_R X/FAST/ PU1/ VEXT/ ES	General-purpose input
	GTM_TIM5_IN4_11			Mux input channel 4 of TIM module 5
	GTM_TIM1_IN0_7			Mux input channel 0 of TIM module 1
	GTM_TIM0_IN0_7			Mux input channel 0 of TIM module 0
	QSPI2_MRSTCN			Master SPI data input (LVDS N line)
	SCU_EMGSTOP_POR T_B			Emergency stop Port Pin B input request
	ASCLIN3_ARXGN			Differential Receive input (low active)
	HSCT0_RXDN			Rx data
	QSPI4_MRSTCN			Master SPI data input (LVDS N line)
	ASCLIN11_ARXE			Receive input
	GTM_DTMA1_0			CDTM1_DTM4
	P21.2	O0		General-purpose output
	GTM_TOUT53	O1		GTM muxed output
	ASCLIN3_ASLSO	O2		Slave select signal output
	—	O3		Reserved
	—	O4		Reserved
	GETH_MDC	O5		MDIO clock
—	O6	Reserved		
—	O7	Reserved		
J19	P21.3	I	LVDS_R X/FAST/ PU1/ VEXT/ ES	General-purpose input
	GTM_TIM5_IN5_12			Mux input channel 5 of TIM module 5
	GTM_TIM1_IN1_6			Mux input channel 1 of TIM module 1
	GTM_TIM0_IN1_6			Mux input channel 1 of TIM module 0
	QSPI2_MRSTCP			Master SPI data input (LVDS P line)
	ASCLIN3_ARXGP			Differential Receive input (high active)
	GETH_MDIOD			MDIO Input
	HSCT0_RXDP			Rx data
	QSPI4_MRSTCP			Master SPI data input (LVDS P line)
	P21.3	O0		General-purpose output
	GTM_TOUT54	O1		GTM muxed output
	ASCLIN11_ASCLK	O2		Shift clock output
	—	O3		Reserved
	—	O4		Reserved
	—	O5		Reserved
	—	O6		Reserved
	—	O7		Reserved
GETH_MDIO	O	MDIO Output		

TC37xEXT Pin Definition and Functions LFBGA-292 Package Pinning of

Table 2-11 Port 21 Functions (cont'd)

Ball	Symbol	Ctrl.	Buffer Type	Function
K20	P21.4	I	LVDS_TX / FAST / PU1 / VEXT / ES6	General-purpose input
	GTM_TIM5_IN6_12			Mux input channel 6 of TIM module 5
	GTM_TIM1_IN2_6			Mux input channel 2 of TIM module 1
	GTM_TIM0_IN2_6			Mux input channel 2 of TIM module 0
	P21.4	O0		General-purpose output
	GTM_TOUT55	O1		GTM muxed output
	ASCLIN11_ASLSO	O2		Slave select signal output
	—	O3		Reserved
	—	O4		Reserved
	—	O5		Reserved
	—	O6		Reserved
	—	O7		Reserved
	H SCT0_TXDN	O		Tx data
J20	P21.5	I	LVDS_TX / FAST / PU1 / VEXT / ES6	General-purpose input
	GTM_TIM5_IN7_11			Mux input channel 7 of TIM module 5
	GTM_TIM1_IN3_6			Mux input channel 3 of TIM module 1
	GTM_TIM0_IN3_6			Mux input channel 3 of TIM module 0
	ASCLIN11_ARXF			Receive input
	P21.5	O0		General-purpose output
	GTM_TOUT56	O1		GTM muxed output
	ASCLIN3_ASCLK	O2		Shift clock output
	ASCLIN11_ATX	O3		Transmit output
	—	O4		Reserved
	—	O5		Reserved
	—	O6		Reserved
	—	O7		Reserved
H SCT0_TXDP	O	Tx data		

TC37xEXT Pin Definition and Functions LFBGA-292 Package Pinning of

Table 2-11 Port 21 Functions (cont'd)

Ball	Symbol	Ctrl.	Buffer Type	Function
H17	P21.6/TDI	I	FAST / PD / PU2 / VEXT / ES3	General-purpose input PD during Reset and in DAP/DAPE or JTAG mode. After Reset release and when not in DAP/DAPE or JTAG mode: PU. In Standby mode: HighZ. DAPE: DAPE1 Data I/O.
	GTM_TIM4_IN2_12			Mux input channel 2 of TIM module 4
	GTM_TIM1_IN4_8			Mux input channel 4 of TIM module 1
	GTM_TIM0_IN4_8			Mux input channel 4 of TIM module 0
	GPT120_T5EUDA			Count direction control input of timer T5
	ASCLIN3_ARXF			Receive input
	CBS_TGI2			Trigger input
	TDI			JTAG Module Data Input
	P21.6	O0	General-purpose output	
	GTM_TOUT57	O1	GTM muxed output	
	ASCLIN3_ASLSO	O2	Slave select signal output	
	—	O3	Reserved	
	—	O4	Reserved	
	—	O5	Reserved	
	—	O6	Reserved	
	GPT120_T3OUT	O7	External output for overflow/underflow detection of core timer T3	
	CBS_TGO2	O	Trigger output	
	DAP3	I/O	DAP: DAP3 Data I/O	
	DAPE1	I/O	DAPE: DAPE1 Data I/O	

TC37xEXT Pin Definition and Functions LFBGA-292 Package Pinning of

Table 2-11 Port 21 Functions (cont'd)

Ball	Symbol	Ctrl.	Buffer Type	Function	
H16	P21.7/TDO	I	FAST / PU2 / VEXT / ES4	General-purpose input DAP: DAP2 Data I/O; DAPE: DAPE2 Data I/O.	
	GTM_TIM4_IN3_12			Mux input channel 3 of TIM module 4	
	GTM_TIM1_IN5_7			Mux input channel 5 of TIM module 1	
	GTM_TIM0_IN5_7			Mux input channel 5 of TIM module 0	
	GPT120_T5INA			Trigger/gate input of timer T5	
	CBS_TGI3			Trigger input	
	GETH_RXERB			Receive Error MII	
	P21.7			O0	General-purpose output
	GTM_TOUT58			O1	GTM muxed output
	ASCLIN3_ATX			O2	Transmit output
	IOM_MON2_15	Monitor input 2			
	IOM_REF2_15	Reference input 2			
	ASCLIN3_ASCLK	O3	Shift clock output		
	—	O4	Reserved		
	—	O5	Reserved		
	—	O6	Reserved		
	GPT120_T6OUT	O7	External output for overflow/underflow detection of core timer T6		
	CBS_TGO3	O	Trigger output		
	DAP2	I/O	DAP: DAP2 Data I/O		
	DAPE2	I/O	DAPE: DAPE2 Data I/O		
TDO	O	JTAG Module Data Output			

TC37xEXT Pin Definition and Functions LFBGA-292 Package Pinning of

Table 2-12 Port 22 Functions

Ball	Symbol	Ctrl.	Buffer Type	Function	
P20	P22.0	I	LVDS_TX / FAST / PU1 / VFLEX2 / ES6	General-purpose input	
	GTM_TIM1_IN1_7			Mux input channel 1 of TIM module 1	
	GTM_TIM0_IN1_7			Mux input channel 1 of TIM module 0	
	QSPI4_MTSRB			Slave SPI data input	
	ASCLIN6_ARXE			Receive input	
	GETH1_CRSDVB			Carrier Sense / Data Valid combi-signal for RMII	
	GETH1_RXDVB			Receive Data Valid MII	
	GETH1_CRSA			Carrier Sense MII	
	P22.0	O0	General-purpose output		
	GTM_TOUT47	O1	GTM muxed output		
	ASCLIN3_ATXN	O2	Differential Transmit output (low active)		
	QSPI4_MTSR	O3	Master SPI data output		
	QSPI4_SCLKN	O4	Master SPI clock output (LVDS N line)		
	MSC1_FCLN	O5	Shift-clock inverted part of the differential signal		
	—	O6	Reserved		
ASCLIN6_ATX	O7	Transmit output			
P19	P22.1	I	LVDS_TX / FAST / PU1 / VFLEX2 / ES6	General-purpose input	
	GTM_TIM1_IN0_8			Mux input channel 0 of TIM module 1	
	GTM_TIM0_IN0_8			Mux input channel 0 of TIM module 0	
	QSPI4_MRSTB			Master SPI data input	
	ASCLIN7_ARXE			Receive input	
	GETH1_RXERA			Receive Error MII	
	P22.1			O0	General-purpose output
	GTM_TOUT48			O1	GTM muxed output
	ASCLIN3_ATXP	O2	Differential Transmit output (high active)		
	QSPI4_MRST	O3	Slave SPI data output		
	IOM_MON2_4		Monitor input 2		
	IOM_REF2_4		Reference input 2		
	QSPI4_SCLKP	O4	Master SPI clock output (LVDS P line)		
	MSC1_FCLP	O5	Shift-clock direct part of the differential signal		
	—	O6	Reserved		
ASCLIN7_ATX	O7	Transmit output			

TC37xEXT Pin Definition and Functions LFBGA-292 Package Pinning of

Table 2-12 Port 22 Functions (cont'd)

Ball	Symbol	Ctrl.	Buffer Type	Function
R20	P22.2	I	LVDS_TX / FAST / PU1 / VEXT / ES6	General-purpose input
	GTM_TIM1_IN3_7			Mux input channel 3 of TIM module 1
	GTM_TIM0_IN3_7			Mux input channel 3 of TIM module 0
	QSPI4_SLSIB			Slave select input
	GETH1_COLA			Collision MII
	P22.2	O0	General-purpose output	
	GTM_TOUT49	O1	GTM muxed output	
	ASCLIN5_ATX	O2	Transmit output	
	QSPI4_SLSO3	O3	Master slave select output	
	QSPI4_MTSRN	O4	Master SPI data output (LVDS N line)	
	MSC1_SON	O5	Data output - inverted part of the differential signal	
	—	O6	Reserved	
	—	O7	Reserved	
R19	P22.3	I	LVDS_TX / FAST / PU1 / VEXT / ES6	General-purpose input
	GTM_TIM1_IN4_4			Mux input channel 4 of TIM module 1
	GTM_TIM0_IN4_4			Mux input channel 4 of TIM module 0
	QSPI4_SCLKB			Slave SPI clock inputs
	ASCLIN5_ARXC			Receive input
	P22.3	O0	General-purpose output	
	GTM_TOUT50	O1	GTM muxed output	
	—	O2	Reserved	
	QSPI4_SCLK	O3	Master SPI clock output	
	QSPI4_MTSRP	O4	Master SPI data output (LVDS P line)	
	MSC1_SOP	O5	Data output - direct part of the differential signal	
	—	O6	Reserved	
	—	O7	Reserved	

TC37xEXT Pin Definition and Functions LFBGA-292 Package Pinning of

Table 2-12 Port 22 Functions (cont'd)

Ball	Symbol	Ctrl.	Buffer Type	Function	
P16	P22.4	I	SLOW / RGMII_In put / PU1 / VFLEX2 / ES	General-purpose input	
	GTM_TIM3_IN0_8			Mux input channel 0 of TIM module 3	
	ASCLIN7_ARXF			Receive input	
	GETH1_RXD0A			Receive Data 0 MII, RMII and RGMII (RGMII can use RXD0A only)	
	GTM_DTMA3_0			CDTM3_DTM4	
	P22.4			O0	General-purpose output
	GTM_TOUT130			O1	GTM muxed output
	ASCLIN4_ASLSO			O2	Slave select signal output
	—			O3	Reserved
	QSPIO_SLSO12			O4	Master slave select output
	—			O5	Reserved
	CAN13_TXD			O6	CAN transmit output node 3
	—	O7	Reserved		
P17	P22.5	I	SLOW / RGMII_In put / PU1 / VFLEX2 / ES	General-purpose input	
	GTM_TIM3_IN1_7			Mux input channel 1 of TIM module 3	
	QSPIO_MTSRC			Slave SPI data input	
	CAN13_RXDC			CAN receive input node 3	
	GETH1_REFCLKA			Reference Clock input for RMII (50 MHz)	
	GETH1_TXCLKB			Transmit Clock Input for MII	
	GETH1_RXCLKA			Receive Clock MII	
	P22.5			O0	General-purpose output
	GTM_TOUT131			O1	GTM muxed output
	ASCLIN4_ATX			O2	Transmit output
	—			O3	Reserved
	QSPIO_MTSR			O4	Master SPI data output
	—	O5	Reserved		
—	O6	Reserved			
—	O7	Reserved			

TC37xEXT Pin Definition and Functions LFBGA-292 Package Pinning of

Table 2-12 Port 22 Functions (cont'd)

Ball	Symbol	Ctrl.	Buffer Type	Function
N16	P22.6	I	SLOW / RGMII_In put / PU1 / VFLEX2 / ES	General-purpose input
	GTM_TIM3_IN2_6			Mux input channel 2 of TIM module 3
	GTM_TIM2_IN6_14			Mux input channel 6 of TIM module 2
	QSPIO_MRSTC			Master SPI data input
	ASCLIN4_ARXC			Receive input
	GETH1_CRSDVA			Carrier Sense / Data Valid combi-signal for RMII
	GETH1_RXDVA			Receive Data Valid MII
	GETH1_CRSB			Carrier Sense MII
	GETH1_RCTLA			Receive Control for RGMII
	P22.6	O0	General-purpose output	
	GTM_TOUT132	O1	GTM muxed output	
	—	O2	Reserved	
	—	O3	Reserved	
	QSPIO_MRST	O4	Slave SPI data output	
	IOM_MON2_0		Monitor input 2	
	IOM_REF2_0		Reference input 2	
	CAN21_TXD	O5	CAN transmit output node 1	
—	O6	Reserved		
—	O7	Reserved		
N17	P22.7	I	SLOW / RGMII_In put / PU1 / VFLEX2 / ES	General-purpose input
	GTM_TIM3_IN3_7			Mux input channel 3 of TIM module 3
	QSPIO_SCLKC			Slave SPI clock inputs
	CAN21_RXDF			CAN receive input node 1
	GETH1_TXCLKA			Transmit Clock Input for MII
	GETH1_GREFCLK			Gigabit Reference Clock input for RGMII (125 MHz high precision)
	P22.7	O0	General-purpose output	
	GTM_TOUT133	O1	GTM muxed output	
	ASCLIN4_ASCLK	O2	Shift clock output	
	—	O3	Reserved	
	QSPIO_SCLK	O4	Master SPI clock output	
	—	O5	Reserved	
	—	O6	Reserved	
	—	O7	Reserved	

TC37xEXT Pin Definition and Functions LFBGA-292 Package Pinning of

Table 2-12 Port 22 Functions (cont'd)

Ball	Symbol	Ctrl.	Buffer Type	Function
M16	P22.8	I	SLOW / PU1 / VFLEX2 / ES	General-purpose input
	GTM_TIM5_IN0_4			Mux input channel 0 of TIM module 5
	GTM_TIM3_IN4_7			Mux input channel 4 of TIM module 3
	QSPIO_SCLKB			Slave SPI clock inputs
	GETH1_RXCLKC			Receive Clock MII
	P22.8	O0	General-purpose output	
	GTM_TOUT134	O1	GTM muxed output	
	ASCLIN5_ASCLK	O2	Shift clock output	
	—	O3	Reserved	
	QSPIO_SCLK	O4	Master SPI clock output	
	CAN22_TXD	O5	CAN transmit output node 2	
	GETH1_MDC	O6	MDIO clock	
	—	O7	Reserved	
M17	P22.9	I	SLOW / PU1 / VFLEX2 / ES	General-purpose input
	GTM_TIM5_IN1_10			Mux input channel 1 of TIM module 5
	GTM_TIM3_IN5_7			Mux input channel 5 of TIM module 3
	QSPIO_MRSTB			Master SPI data input
	ASCLIN4_ARXD			Receive input
	CAN22_RXDE			CAN receive input node 2
	GETH1_MDIOC			MDIO Input
	GTM_DTMA3_1			CDTM3_DTM4
	P22.9			O0
	GTM_TOUT135	O1	GTM muxed output	
	—	O2	Reserved	
	—	O3	Reserved	
	QSPIO_MRST	O4	Slave SPI data output	
	IOM_MON2_0		Monitor input 2	
	IOM_REF2_0		Reference input 2	
	—		O5	Reserved
	—	O6	Reserved	
	—	O7	Reserved	
GETH1_MDIO	O	MDIO Output		

TC37xEXT Pin Definition and Functions LFBGA-292 Package Pinning of

Table 2-12 Port 22 Functions (cont'd)

Ball	Symbol	Ctrl.	Buffer Type	Function
L16	P22.10	I	RFAST / PU1 / VFLEX2 / ES	General-purpose input
	GTM_TIM5_IN2_8			Mux input channel 2 of TIM module 5
	GTM_TIM3_IN6_7			Mux input channel 6 of TIM module 3
	QSPI0_MTSRB			Slave SPI data input
	P22.10	O0		General-purpose output
	GTM_TOUT136	O1		GTM muxed output
	ASCLIN4_ATX	O2		Transmit output
	—	O3		Reserved
	QSPI0_MTSR	O4		Master SPI data output
	CAN23_TXD	O5		CAN transmit output node 3
	GETH1_TXD0	O6		Transmit Data
	—	O7		Reserved
L17	P22.11	I	RFAST / PU1 / VFLEX2 / ES	General-purpose input
	GTM_TIM5_IN3_10			Mux input channel 3 of TIM module 5
	GTM_TIM3_IN7_7			Mux input channel 7 of TIM module 3
	CAN23_RXDE			CAN receive input node 3
	P22.11	O0		General-purpose output
	GTM_TOUT137	O1		GTM muxed output
	ASCLIN4_ASLSO	O2		Slave select signal output
	—	O3		Reserved
	QSPI0_SLSO10	O4		Master slave select output
	—	O5		Reserved
	GETH1_TXEN	O6		Transmit Enable MII and RMII
	GETH1_TCTL			Transmit Control for RGMII
	—	O7		Reserved

TC37xEXT Pin Definition and Functions LFBGA-292 Package Pinning of

Table 2-13 Port 23 Functions

Ball	Symbol	Ctrl.	Buffer Type	Function
V20	P23.0	I	SLOW / PU1 / VEXT / ES	General-purpose input
	GTM_TIM1_IN5_4			Mux input channel 5 of TIM module 1
	GTM_TIM0_IN5_4			Mux input channel 5 of TIM module 0
	CAN10_RXDC			CAN receive input node 0
	P23.0	O0		General-purpose output
	GTM_TOUT41	O1		GTM muxed output
	—	O2		Reserved
	—	O3		Reserved
	—	O4		Reserved
	—	O5		Reserved
	—	O6		Reserved
	—	O7		Reserved
U19	P23.1	I	FAST / PU1 / VEXT / ES	General-purpose input
	GTM_TIM1_IN6_4			Mux input channel 6 of TIM module 1
	GTM_TIM0_IN6_4			Mux input channel 6 of TIM module 0
	MSC1_SDI0			Upstream asynchronous input signal
	ASCLIN6_ARXF			Receive input
	P23.1	O0		General-purpose output
	GTM_TOUT42	O1		GTM muxed output
	ASCLIN1_ARTS	O2		Ready to send output
	QSPI4_SLSO6	O3		Master slave select output
	GTM_CLK0	O4		CGM generated clock
	CAN10_TXD	O5		CAN transmit output node 0
	CCU_EXTCLK0	O6		External Clock 0
ASCLIN6_ASCLK	O7	Shift clock output		
U20	P23.2	I	RFAST / PU1 / VFLEX2 / ES	General-purpose input
	GTM_TIM1_IN6_5			Mux input channel 6 of TIM module 1
	GTM_TIM0_IN6_5			Mux input channel 6 of TIM module 0
	ASCLIN7_ARXC			Receive input
	P23.2	O0		General-purpose output
	GTM_TOUT43	O1		GTM muxed output
	—	O2		Reserved
	—	O3		Reserved
	CAN23_TXD	O4		CAN transmit output node 3
	CAN12_TXD	O5		CAN transmit output node 2
	GETH1_TXD3	O6		Transmit Data
	—	O7		Reserved

TC37xEXT Pin Definition and Functions LFBGA-292 Package Pinning of

Table 2-13 Port 23 Functions (cont'd)

Ball	Symbol	Ctrl.	Buffer Type	Function
T19	P23.3	I	RFAST / PU1 / VFLEX2 / ES	General-purpose input
	GTM_TIM1_IN7_4			Mux input channel 7 of TIM module 1
	GTM_TIM0_IN7_4			Mux input channel 7 of TIM module 0
	MSC1_INJ0			Injection signal from port
	ASCLIN6_ARXA			Receive input
	CAN12_RXDC			CAN receive input node 2
	CAN23_RXDB			CAN receive input node 3
	P23.3			O0
	GTM_TOUT44	O1	GTM muxed output	
	ASCLIN7_ATX	O2	Transmit output	
	—	O3	Reserved	
	—	O4	Reserved	
	—	O5	Reserved	
	GETH1_TXD2	O6	Transmit Data	
—	O7	Reserved		
T20	P23.4	I	RFAST / PU1 / VFLEX2 / ES	General-purpose input
	GTM_TIM1_IN7_5			Mux input channel 7 of TIM module 1
	GTM_TIM0_IN7_5			Mux input channel 7 of TIM module 0
	P23.4	O0	General-purpose output	
	GTM_TOUT45	O1	GTM muxed output	
	ASCLIN6_ASLSO	O2	Slave select signal output	
	QSPI4_SLSO5	O3	Master slave select output	
	—	O4	Reserved	
	MSC1_EN0	O5	Chip Select	
	GETH1_TXD1	O6	Transmit Data	
	—	O7	Reserved	

TC37xEXT Pin Definition and Functions LFBGA-292 Package Pinning of

Table 2-13 Port 23 Functions (cont'd)

Ball	Symbol	Ctrl.	Buffer Type	Function
T17	P23.5	I	FAST / RGMII_In put / PU1 / VFLEX2 / ES	General-purpose input
	GTM_TIM1_IN2_7			Mux input channel 2 of TIM module 1
	GTM_TIM0_IN2_7			Mux input channel 2 of TIM module 0
	GETH1_RXD3A			Receive Data 3 MII and RGMII (RGMII can use RXD3A only)
	P23.5	O0	General-purpose output	
	GTM_TOUT46	O1	GTM muxed output	
	ASCLIN6_ATX	O2	Transmit output	
	QSPI4_SLSO4	O3	Master slave select output	
	—	O4	Reserved	
	MSC1_EN1	O5	Chip Select	
	CAN22_TXD	O6	CAN transmit output node 2	
—	O7	Reserved		
R17	P23.6	I	SLOW / RGMII_In put / PU1 / VFLEX2 / ES	General-purpose input
	GTM_TIM4_IN2_7			Mux input channel 2 of TIM module 4
	GTM_TIM1_IN2_10			Mux input channel 2 of TIM module 1
	CAN22_RXDC			CAN receive input node 2
	GETH1_RXD2A			Receive Data 2 MII and RGMII (RGMII can use RXD2A only)
	P23.6	O0	General-purpose output	
	GTM_TOUT138	O1	GTM muxed output	
	—	O2	Reserved	
	—	O3	Reserved	
	QSPI0_SLSO11	O4	Master slave select output	
	CAN11_TXD	O5	CAN transmit output node 1	
—	O6	Reserved		
—	O7	Reserved		

TC37xEXT Pin Definition and Functions LFBGA-292 Package Pinning of

Table 2-13 Port 23 Functions (cont'd)

Ball	Symbol	Ctrl.	Buffer Type	Function
R16	P23.7	I	SLOW / RGMII_Input / PU1 / VFLEX2 / ES	General-purpose input
	GTM_TIM4_IN3_7			Mux input channel 3 of TIM module 4
	GTM_TIM1_IN3_10			Mux input channel 3 of TIM module 1
	CAN11_RXDC			CAN receive input node 1
	GETH1_RXD1A			Receive Data 1 MII, RMI and RGMII (RGMII can use RXD1A only)
	P23.7	O0	General-purpose output	
	GTM_TOUT139	O1	GTM muxed output	
	—	O2	Reserved	
	—	O3	Reserved	
	—	O4	Reserved	
	—	O5	Reserved	
	—	O6	Reserved	
	—	O7	Reserved	

Table 2-14 Port 32 Functions

Ball	Symbol	Ctrl.	Buffer Type	Function
Y17	P32.0	I	SLOW / PU1 / VEXT / ES	General-purpose input P32.0 / SMPS mode: analog output. External Pass Device gate control for EVRC
	GTM_TIM3_IN2_5			Mux input channel 2 of TIM module 3
	GTM_TIM2_IN2_5			Mux input channel 2 of TIM module 2
	P32.0	O0	General-purpose output	
	GTM_TOUT36	O1	GTM muxed output	
	—	O2	Reserved	
	—	O3	Reserved	
	—	O4	Reserved	
	—	O5	Reserved	
	—	O6	Reserved	
	—	O7	Reserved	

TC37xEXT Pin Definition and Functions LFBGA-292 Package Pinning of

Table 2-14 Port 32 Functions (cont'd)

Ball	Symbol	Ctrl.	Buffer Type	Function
W17	P32.1	I	SLOW / PU1 / VEXT / ES	General-purpose input P32.1 / External Pass Device gate control for EVRC
	GTM_TIM3_IN3_15			Mux input channel 3 of TIM module 3
	P32.1	O0		General-purpose output
	GTM_TOUT37	O1		GTM muxed output
	—	O2		Reserved
	—	O3		Reserved
	—	O4		Reserved
	—	O5		Reserved
	—	O6		Reserved
	—	O7		Reserved
Y18	P32.2	I	SLOW / PU1 / VEXT / ES	General-purpose input
	GTM_TIM1_IN3_8			Mux input channel 3 of TIM module 1
	GTM_TIM0_IN3_8			Mux input channel 3 of TIM module 0
	CAN03_RXDB			CAN receive input node 3
	ASCLIN3_ARXD			Receive input
	CAN21_RXDD			CAN receive input node 1
	P32.2			O0
	GTM_TOUT38	O1		GTM muxed output
	ASCLIN3_ATX	O2		Transmit output
	IOM_MON2_15			Monitor input 2
	IOM_REF2_15			Reference input 2
	—			O3
	—	O4		Reserved
	—	O5		Reserved
	PMS_DCDCSYNCO	O6		DC-DC synchronization output
—	O7	Reserved		

TC37xEXT Pin Definition and Functions LFBGA-292 Package Pinning of

Table 2-14 Port 32 Functions (cont'd)

Ball	Symbol	Ctrl.	Buffer Type	Function
Y19	P32.3	I	SLOW / PU1 / VEXT / ES	General-purpose input
	GTM_TIM1_IN4_5			Mux input channel 4 of TIM module 1
	GTM_TIM0_IN4_5			Mux input channel 4 of TIM module 0
	P32.3	O0		General-purpose output
	GTM_TOUT39	O1		GTM muxed output
	ASCLIN3_ATX	O2		Transmit output
	IOM_MON2_15			Monitor input 2
	IOM_REF2_15	O3		Reference input 2
	—			Reserved
	ASCLIN3_ASCLK			O4
	CAN03_TXD	O5		CAN transmit output node 3
	IOM_MON2_8	O6		Monitor input 2
	IOM_REF2_8			Reference input 2
	CAN21_TXD	O6		CAN transmit output node 1
	—	O7		Reserved
W18	P32.4	I	FAST / PU1 / VEXT / ES	General-purpose input
	GTM_TIM1_IN5_5			Mux input channel 5 of TIM module 1
	GTM_TIM0_IN5_5			Mux input channel 5 of TIM module 0
	ASCLIN1_ACTSB			Clear to send input
	MSC1_SDI2			Upstream asynchronous input signal
	P32.4	O0		General-purpose output
	GTM_TOUT40	O1		GTM muxed output
	—	O2		Reserved
	—	O3		Reserved
	GTM_CLK1	O4		CGM generated clock
	MSC1_EN0	O5		Chip Select
	CCU_EXTCLK1	O6		External Clock 1
	CCU60_COUT63	O7		T13 PWM channel 63
	IOM_MON1_6			Monitor input 1
	IOM_REF1_0	O		Reference input 1
PMS_DCDCSYNCO	DC-DC synchronization output			

TC37xEXT Pin Definition and Functions LFBGA-292 Package Pinning of

Table 2-14 Port 32 Functions (cont'd)

Ball	Symbol	Ctrl.	Buffer Type	Function	
T15	P32.5	I	SLOW / PU1 / VEXT / ES	General-purpose input	
	GTM_TIM5_IN5_9			Mux input channel 5 of TIM module 5	
	GTM_TIM4_IN1_14			Mux input channel 1 of TIM module 4	
	GTM_TIM3_IN5_8			Mux input channel 5 of TIM module 3	
	SENT_SENT10C			Receive input channel 10	
	P32.5			O0	General-purpose output
	GTM_TOUT140			O1	GTM muxed output
	ASCLIN2_ATX			O2	Transmit output
	IOM_MON2_14			O3	Monitor input 2
	IOM_REF2_14				Reference input 2
	—				Reserved
	—				Reserved
	—			O4	Reserved
	—			O5	Reserved
	CAN02_TXD			O6	CAN transmit output node 2
	IOM_MON2_7			O7	Monitor input 2
IOM_REF2_7	Reference input 2				
—	Reserved				
U15	P32.6	I	SLOW / PU1 / VEXT / ES	General-purpose input	
	GTM_TIM5_IN6_9			Mux input channel 6 of TIM module 5	
	GTM_TIM4_IN4_15			Mux input channel 4 of TIM module 4	
	GTM_TIM3_IN6_8			Mux input channel 6 of TIM module 3	
	CAN02_RXDC			CAN receive input node 2	
	CBS_TGI4			Trigger input	
	ASCLIN2_ARXF			Receive input	
	ASCLIN6_ARXC			Receive input	
	SENT_SENT11C			Receive input channel 11	
	P32.6			O0	General-purpose output
	GTM_TOUT141			O1	GTM muxed output
	—			O2	Reserved
	—			O3	Reserved
	QSPI2_SLSO12			O4	Master slave select output
	CAN22_TXD			O5	CAN transmit output node 2
	—			O6	Reserved
—	O7	Reserved			
CBS_TGO4	O	Trigger output			

TC37xEXT Pin Definition and Functions LFBGA-292 Package Pinning of

Table 2-14 Port 32 Functions (cont'd)

Ball	Symbol	Ctrl.	Buffer Type	Function
U16	P32.7	I	SLOW / PU1 / VEXT / ES	General-purpose input
	GTM_TIM5_IN7_8			Mux input channel 7 of TIM module 5
	GTM_TIM4_IN0_15			Mux input channel 0 of TIM module 4
	GTM_TIM3_IN7_8			Mux input channel 7 of TIM module 3
	CBS_TGI5			Trigger input
	CAN22_RXDB			CAN receive input node 2
	SENT_SENT12C			Receive input channel 12
	P32.7			O0
	GTM_TOUT142	O1	GTM muxed output	
	ASCLIN6_ATX	O2	Transmit output	
	—	O3	Reserved	
	—	O4	Reserved	
	—	O5	Reserved	
	—	O6	Reserved	
	—	O7	Reserved	
	CBS_TGO5	O	Trigger output	

TC37xEXT Pin Definition and Functions LFBGA-292 Package Pinning of

Table 2-15 Port 33 Functions

Ball	Symbol	Ctrl.	Buffer Type	Function
W10	P33.0	I	SLOW / PU1 / VEVRSB / ES5	General-purpose input
	GTM_TIM3_IN0_13			Mux input channel 0 of TIM module 3
	GTM_TIM1_IN4_6			Mux input channel 4 of TIM module 1
	GTM_TIM0_IN4_6			Mux input channel 4 of TIM module 0
	EDSADC_ITR0E			Trigger/Gate input, channel 0
	SENT_SENT13C			Receive input channel 13
	IOM_PIN_0			GPIO pad input to FPC
	GTM_DTMT1_2			CDTM1_DTM0
	EVADC_G10CH7	AI		Analog input channel 7, group 10
	P33.0	O0	General-purpose output	
	GTM_TOUT22	O1	GTM muxed output	
	IOM_MON0_0		Monitor input 0	
	IOM_GTM_0		GTM-provided inputs to EXOR combiner	
	ASCLIN5_ATX	O2	Transmit output	
	—	O3	Reserved	
	—	O4	Reserved	
	—	O5	Reserved	
	EVADC_FC2BFLOUT	O6	Boundary flag output, FC channel 2	
	—	O7	Reserved	

TC37xEXT Pin Definition and Functions LFBGA-292 Package Pinning of

Table 2-15 Port 33 Functions (cont'd)

Ball	Symbol	Ctrl.	Buffer Type	Function
Y10	P33.1	I	SLOW / PU1 / VEVRSB / ES5	General-purpose input
	GTM_TIM3_IN1_15			Mux input channel 1 of TIM module 3
	GTM_TIM1_IN5_6			Mux input channel 5 of TIM module 1
	GTM_TIM0_IN5_6			Mux input channel 5 of TIM module 0
	EDSADC_ITR1E			Trigger/Gate input, channel 1
	PSI5_RX0C			RXD inputs (receive data) channel 0
	EDSADC_DSCIN2B			Modulator clock input, channel 2
	SENT_SENT9C			Receive input channel 9
	ASCLIN8_ARXC			Receive input
	IOM_PIN_1			GPIO pad input to FPC
	EVADC_G10CH6	AI	Analog input channel 6, group 10	
	P33.1	O0	General-purpose output	
	GTM_TOUT23	O1	GTM muxed output	
	IOM_MON0_1		Monitor input 0	
	IOM_GTM_1	O2	GTM-provided inputs to EXOR combiner	
	ASCLIN3_ASLSO		Slave select signal output	
	QSPI2_SCLK	O3	Master SPI clock output	
	EDSADC_DSCOUT2	O4	Modulator clock output	
	EVADC_EMUX02	O5	Control of external analog multiplexer interface 0	
	—	O6	Reserved	
—	O7	Reserved		

TC37xEXT Pin Definition and Functions LFBGA-292 Package Pinning of

Table 2-15 Port 33 Functions (cont'd)

Ball	Symbol	Ctrl.	Buffer Type	Function
W11	P33.2	I	SLOW / PU1 / VEVRSB / ES5	General-purpose input
	GTM_TIM3_IN2_14			Mux input channel 2 of TIM module 3
	GTM_TIM1_IN6_6			Mux input channel 6 of TIM module 1
	GTM_TIM0_IN6_6			Mux input channel 6 of TIM module 0
	EDSADC_ITR2E			Trigger/Gate input, channel 2
	SENT_SENT8C			Receive input channel 8
	EDSADC_DSDIN2B			Digital datastream input, channel 2
	IOM_PIN_2			GPIO pad input to FPC
	EVADC_G10CH5			AI
	P33.2	O0	General-purpose output	
	GTM_TOUT24	O1	GTM muxed output	
	IOM_MON0_2		Monitor input 0	
	IOM_GTM_2		GTM-provided inputs to EXOR combiner	
	ASCLIN3_ASCLK		O2	Shift clock output
	QSPI2_SLSO10	O3	Master slave select output	
	PSI5_TX0	O4	TXD outputs (send data)	
	IOM_MON1_14		Monitor input 1	
	IOM_REF1_14		Reference input 1	
	EVADC_EMUX01	O5	Control of external analog multiplexer interface 0	
	EVADC_FC3BFLOUT	O6	Boundary flag output, FC channel 3	
—	O7	Reserved		

TC37xEXT Pin Definition and Functions LFBGA-292 Package Pinning of

Table 2-15 Port 33 Functions (cont'd)

Ball	Symbol	Ctrl.	Buffer Type	Function
Y11	P33.3	I	SLOW / PU1 / VEVRSB / ES5	General-purpose input
	GTM_TIM3_IN3_12			Mux input channel 3 of TIM module 3
	GTM_TIM1_IN7_6			Mux input channel 7 of TIM module 1
	GTM_TIM0_IN7_6			Mux input channel 7 of TIM module 0
	PSI5_RX1C			RXD inputs (receive data) channel 1
	SENT_SENT7C			Receive input channel 7
	EDSADC_DSCIN1B			Modulator clock input, channel 1
	IOM_PIN_3			GPIO pad input to FPC
	EVADC_G10CH4			AI
	P33.3	O0	General-purpose output	
	GTM_TOUT25	O1	GTM muxed output	
	IOM_MON0_3		Monitor input 0	
	IOM_GTM_3		GTM-provided inputs to EXOR combiner	
	ASCLIN5_ASCLK	O2	Shift clock output	
	QSPI4_SLSO2	O3	Master slave select output	
	EDSADC_DSCOUT1	O4	Modulator clock output	
	EVADC_EMUX00	O5	Control of external analog multiplexer interface 0	
	—	O6	Reserved	
	—	O7	Reserved	

TC37xEXT Pin Definition and Functions LFBGA-292 Package Pinning of

Table 2-15 Port 33 Functions (cont'd)

Ball	Symbol	Ctrl.	Buffer Type	Function
W12	P33.4	I	SLOW / PU1 / VEVRSB / ES5	General-purpose input
	GTM_TIM4_IN4_10			Mux input channel 4 of TIM module 4
	GTM_TIM1_IN0_10			Mux input channel 0 of TIM module 1
	GTM_TIM0_IN0_10			Mux input channel 0 of TIM module 0
	EDSADC_ITR0F			Trigger/Gate input, channel 0
	SENT_SENT6C			Receive input channel 6
	EDSADC_DSDIN1B			Digital datastream input, channel 1
	CCU61_CTRAPC			Trap input capture
	ASCLIN5_ARXB			Receive input
	IOM_PIN_4			GPIO pad input to FPC
	GTM_DTMT2_0			CDTM2_DTM0
	EVADC_G10CH3	AI	Analog input channel 3, group 10	
	P33.4	O0	General-purpose output	
	GTM_TOUT26	O1	GTM muxed output	
	IOM_MON0_4		Monitor input 0	
	IOM_GTM_4		GTM-provided inputs to EXOR combiner	
	ASCLIN2_ARTS	O2	Ready to send output	
	QSPI2_SLSO12	O3	Master slave select output	
	PSI5_TX1	O4	TXD outputs (send data)	
	IOM_MON1_15		Monitor input 1	
EVADC_EMUX12	O5	Control of external analog multiplexer interface 1		
EVADC_FC0BFLOUT	O6	Boundary flag output, FC channel 0		
CAN13_TXD	O7	CAN transmit output node 3		

TC37xEXT Pin Definition and Functions LFBGA-292 Package Pinning of

Table 2-15 Port 33 Functions (cont'd)

Ball	Symbol	Ctrl.	Buffer Type	Function
Y12	P33.5	I	SLOW / PU1 / VEVRSB / ES5	General-purpose input
	GTM_TIM4_IN5_10			Mux input channel 5 of TIM module 4
	GTM_TIM1_IN1_8			Mux input channel 1 of TIM module 1
	GTM_TIM0_IN1_8			Mux input channel 1 of TIM module 0
	EDSADC_DSCIN0B			Modulator clock input, channel 0
	EDSADC_ITR1F			Trigger/Gate input, channel 1
	GPT120_T4EUDB			Count direction control input of timer T4
	PSI5S_RXC			RX data input
	ASCLIN2_ACTSB			Clear to send input
	CCU61_CCPOS2C			Hall capture input 2
	SENT_SENT5C			Receive input channel 5
	CAN13_RXDB			CAN receive input node 3
	IOM_PIN_5			GPIO pad input to FPC
	EVADC_G10CH2	AI	Analog input channel 2, group 10	
	P33.5	O0	General-purpose output	
	GTM_TOUT27	O1	GTM muxed output	
	IOM_MON0_5		Monitor input 0	
	IOM_GTM_5		GTM-provided inputs to EXOR combiner	
	QSPI0_SLSO7	O2	Master slave select output	
	QSPI1_SLSO7	O3	Master slave select output	
EDSADC_DSCOUT0	O4	Modulator clock output		
EVADC_EMUX11	O5	Control of external analog multiplexer interface 1		
EVADC_FC2BFLOUT	O6	Boundary flag output, FC channel 2		
ASCLIN5_ASLSO	O7	Slave select signal output		

TC37xEXT Pin Definition and Functions LFBGA-292 Package Pinning of

Table 2-15 Port 33 Functions (cont'd)

Ball	Symbol	Ctrl.	Buffer Type	Function
W13	P33.6	I	SLOW / PU1 / VEVRSB / ES5	General-purpose input
	GTM_TIM1_IN2_9			Mux input channel 2 of TIM module 1
	GTM_TIM0_IN2_9			Mux input channel 2 of TIM module 0
	EDSADC_ITR2F			Trigger/Gate input, channel 2
	GPT120_T2EUDB			Count direction control input of timer T2
	SENT_SENT4C			Receive input channel 4
	CCU61_CCPOS1C			Hall capture input 1
	EDSADC_DSDIN0B			Digital datastream input, channel 0
	ASCLIN8_ARXD			Receive input
	IOM_PIN_6			GPIO pad input to FPC
	GTM_DTMT2_1			CDTM2_DTM0
	EVADC_G10CH1			AI
	P33.6	O0	General-purpose output	
	GTM_TOUT28	O1	GTM muxed output	
	IOM_MON0_6		Monitor input 0	
	IOM_GTM_6		GTM-provided inputs to EXOR combiner	
	ASCLIN2_ASLSO	O2	Slave select signal output	
	QSPI2_SLSO11	O3	Master slave select output	
	—	O4	Reserved	
	EVADC_EMUX10	O5	Control of external analog multiplexer interface 1	
EVADC_FC1BFLOUT	O6	Boundary flag output, FC channel 1		
PSI5S_TX	O7	TX data output		

TC37xEXT Pin Definition and Functions LFBGA-292 Package Pinning of

Table 2-15 Port 33 Functions (cont'd)

Ball	Symbol	Ctrl.	Buffer Type	Function
Y13	P33.7	I	SLOW / PU1 / VEVRSB / ES5	General-purpose input
	GTM_TIM1_IN3_9			Mux input channel 3 of TIM module 1
	GTM_TIM0_IN3_9			Mux input channel 3 of TIM module 0
	CAN00_RXDE			CAN receive input node 0
	GPT120_T2INB			Trigger/gate input of timer T2
	CCU61_CCPOS0C			Hall capture input 0
	SCU_E_REQ4_0			ERU Channel 4 inputs 0 to 5 (0 is the LSB and 5 is the MSB)
	SENT_SENT14C			Receive input channel 14
	IOM_PIN_7			GPIO pad input to FPC
	EVADC_G10CH0			Analog input channel 0, group 10
	P33.7	O0	General-purpose output	
	GTM_TOUT29	O1	GTM muxed output	
	IOM_MON0_7	O1	Monitor input 0	
	IOM_GTM_7		GTM-provided inputs to EXOR combiner	
	ASCLIN2_ASCLK	O2	Shift clock output	
	QSPI4_SLSO7	O3	Master slave select output	
	ASCLIN8_ATX	O4	Transmit output	
	—	O5	Reserved	
	EVADC_FC3BFLOUT	O6	Boundary flag output, FC channel 3	
	—	O7	Reserved	

TC37xEXT Pin Definition and Functions LFBGA-292 Package Pinning of

Table 2-15 Port 33 Functions (cont'd)

Ball	Symbol	Ctrl.	Buffer Type	Function
W14	P33.8	I	FAST / HighZ / VEVR SB	General-purpose input
	GTM_TIM1_IN4_7			Mux input channel 4 of TIM module 1
	GTM_TIM0_IN4_7			Mux input channel 4 of TIM module 0
	ASCLIN2_ARXE			Receive input
	SCU_EMGSTOP_POR T_A			Emergency stop Port Pin A input request
	IOM_PIN_8			GPIO pad input to FPC
	P33.8	O0		General-purpose output
	GTM_TOUT30	O1		GTM muxed output
	IOM_MON0_8	O2		Monitor input 0
	ASCLIN2_ATX		Transmit output	
	IOM_MON2_14		Monitor input 2	
	IOM_REF2_14		Reference input 2	
	QSPI4_SLSO2	O3		Master slave select output
	—	O4		Reserved
	CAN00_TXD	O5		CAN transmit output node 0
	IOM_MON2_5	O6		Monitor input 2
	IOM_REF2_5		Reference input 2	
	—		Reserved	
	CCU61_COUT62	O7		T12 PWM channel 62
	IOM_MON1_13	O		Monitor input 1
IOM_REF1_8	Reference input 1			
SMU_FSP0			FSP[1..0] Output Signals - Generated by SMU_core	

TC37xEXT Pin Definition and Functions LFBGA-292 Package Pinning of

Table 2-15 Port 33 Functions (cont'd)

Ball	Symbol	Ctrl.	Buffer Type	Function
Y14	P33.9	I	SLOW / PU1 / VEVRSB / ES5	General-purpose input
	GTM_TIM1_IN1_9			Mux input channel 1 of TIM module 1
	GTM_TIM0_IN1_9			Mux input channel 1 of TIM module 0
	IOM_PIN_9			GPIO pad input to FPC
	P33.9	O0	SLOW / PU1 / VEVRSB / ES5	General-purpose output
	GTM_TOUT31	O1		GTM muxed output
	IOM_MON0_9	O2		Monitor input 0
	ASCLIN2_ATX			Transmit output
	IOM_MON2_14			Monitor input 2
	IOM_REF2_14	O3		Reference input 2
	QSPI4_SLSO1			Master slave select output
	ASCLIN2_ASCLK	O4		Shift clock output
	CAN01_TXD	O5		CAN transmit output node 1
	IOM_MON2_6			Monitor input 2
	IOM_REF2_6			Reference input 2
	ASCLIN0_ATX	O6		Transmit output
	IOM_MON2_12			Monitor input 2
	IOM_REF2_12			Reference input 2
	CCU61_CC62	O7		T12 PWM channel 62
	IOM_MON1_10			Monitor input 1
IOM_REF1_11	Reference input 1			

TC37xEXT Pin Definition and Functions LFBGA-292 Package Pinning of

Table 2-15 Port 33 Functions (cont'd)

Ball	Symbol	Ctrl.	Buffer Type	Function
W15	P33.10	I	FAST / PU1 / VEVR SB / ES5	General-purpose input
	GTM_TIM4_IN4_14			Mux input channel 4 of TIM module 4
	GTM_TIM1_IN0_9			Mux input channel 0 of TIM module 1
	GTM_TIM0_IN0_9			Mux input channel 0 of TIM module 0
	QSPI4_SLSIA			Slave select input
	CAN01_RXDD			CAN receive input node 1
	ASCLIN0_ARXD			Receive input
	IOM_PIN_10			GPIO pad input to FPC
	P33.10			O0
	GTM_TOUT32	O1	GTM muxed output	
	IOM_MON0_10		Monitor input 0	
	QSPI1_SLSO6	O2	Master slave select output	
	QSPI4_SLSO0	O3	Master slave select output	
	ASCLIN1_ASLSO	O4	Slave select signal output	
	PSI5S_CLK	O5	PSI5S CLK is a clock that can be used on a pin to drive the external PHY.	
	—	O6	Reserved	
	CCU61_COUT61	O7	T12 PWM channel 61	
	IOM_MON1_12		Monitor input 1	
	IOM_REF1_9		Reference input 1	
SMU_FSP1	O	FSP[1..0] Output Signals - Generated by SMU_core		
Y15	P33.11	I	FAST / PU1 / VEVR SB / ES5	General-purpose input
	GTM_TIM1_IN2_8			Mux input channel 2 of TIM module 1
	GTM_TIM0_IN2_8			Mux input channel 2 of TIM module 0
	QSPI4_SCLKA			Slave SPI clock inputs
	IOM_PIN_11			GPIO pad input to FPC
	P33.11	O0	General-purpose output	
	GTM_TOUT33	O1	GTM muxed output	
	IOM_MON0_11		Monitor input 0	
	ASCLIN1_ASCLK	O2	Shift clock output	
	QSPI4_SCLK	O3	Master SPI clock output	
	—	O4	Reserved	
	—	O5	Reserved	
	EDSADC_CGPWMN	O6	Negative carrier generator output	
	CCU61_CC61	O7	T12 PWM channel 61	
	IOM_MON1_9		Monitor input 1	
IOM_REF1_12		Reference input 1		

TC37xEXT Pin Definition and Functions LFBGA-292 Package Pinning of

Table 2-15 Port 33 Functions (cont'd)

Ball	Symbol	Ctrl.	Buffer Type	Function
W16	P33.12	I	FAST / PU1 / VEVRSB / ES5	General-purpose input
	GTM_TIM3_IN0_6			Mux input channel 0 of TIM module 3
	GTM_TIM2_IN0_6			Mux input channel 0 of TIM module 2
	QSPI4_MTSRA			Slave SPI data input
	CAN00_RXDD			CAN receive input node 0
	PMS_PINBWKP			PINB (P33.12) pin input
	IOM_PIN_12			GPIO pad input to FPC
	P33.12	O0	General-purpose output	
	GTM_TOUT34	O1	GTM muxed output	
	IOM_MON0_12	O2	Monitor input 0	
	ASCLIN1_ATX		Transmit output	
	IOM_MON2_13		Monitor input 2	
	IOM_REF2_13	O3	Reference input 2	
	QSPI4_MTSR		Master SPI data output	
	ASCLIN1_ASCLK	O4	Shift clock output	
	CAN22_TXD	O5	CAN transmit output node 2	
	EDSADC_CGPWMP	O6	Positive carrier generator output	
	CCU61_COUT60	O7	T12 PWM channel 60	
	IOM_MON1_11		Monitor input 1	
	IOM_REF1_10		Reference input 1	

TC37xEXT Pin Definition and Functions LFBGA-292 Package Pinning of

Table 2-15 Port 33 Functions (cont'd)

Ball	Symbol	Ctrl.	Buffer Type	Function
Y16	P33.13	I	FAST / PU1 / VEVRSB / ES5	General-purpose input
	GTM_TIM3_IN1_5			Mux input channel 1 of TIM module 3
	GTM_TIM2_IN1_5			Mux input channel 1 of TIM module 2
	ASCLIN1_ARXF			Receive input
	EDSADC_SGNB			Carrier sign signal input
	QSPI4_MRSTA			Master SPI data input
	MSC1_INJ1			Injection signal from port
	CAN22_RXDA			CAN receive input node 2
	P33.13	O0	General-purpose output	
	GTM_TOUT35	O1	GTM muxed output	
	ASCLIN1_ATX	O2	Transmit output	
	IOM_MON2_13		Monitor input 2	
	IOM_REF2_13		Reference input 2	
	QSPI4_MRST	O3	Slave SPI data output	
	IOM_MON2_4		Monitor input 2	
	IOM_REF2_4		Reference input 2	
	QSPI2_SLSO6	O4	Master slave select output	
	CAN00_TXD	O5	CAN transmit output node 0	
	IOM_MON2_5		Monitor input 2	
	IOM_REF2_5		Reference input 2	
	—	O6	Reserved	
	CCU61_CC60	O7	T12 PWM channel 60	
	IOM_MON1_8		Monitor input 1	
	IOM_REF1_13		Reference input 1	

TC37xEXT Pin Definition and Functions LFBGA-292 Package Pinning of

Table 2-15 Port 33 Functions (cont'd)

Ball	Symbol	Ctrl.	Buffer Type	Function
T14	P33.14	I	FAST / PU1 / VEVR SB / ES5	General-purpose input
	GTM_TIM5_IN0_8			Mux input channel 0 of TIM module 5
	GTM_TIM4_IN5_14			Mux input channel 5 of TIM module 4
	GTM_TIM2_IN0_8			Mux input channel 0 of TIM module 2
	QSPI2_SCLKD			Slave SPI clock inputs
	CBS_TGI6			Trigger input
	P33.14	O0	SLOW / PU1 / VEVR SB / ES5	General-purpose output
	GTM_TOUT143	O1		GTM muxed output
	—	O2		Reserved
	QSPI2_SCLK	O3		Master SPI clock output
	—	O4		Reserved
	—	O5		Reserved
	—	O6		Reserved
	CCU60_CC62	O7		T12 PWM channel 62
	IOM_MON1_0	O		Monitor input 1
	IOM_REF1_4			Reference input 1
CBS_TGO6	O	Trigger output		
U14	P33.15	I	SLOW / PU1 / VEVR SB / ES5	General-purpose input
	GTM_TIM5_IN1_9			Mux input channel 1 of TIM module 5
	GTM_TIM4_IN6_12			Mux input channel 6 of TIM module 4
	GTM_TIM2_IN1_7			Mux input channel 1 of TIM module 2
	CBS_TGI7			Trigger input
	P33.15	O0	SLOW / PU1 / VEVR SB / ES5	General-purpose output
	GTM_TOUT144	O1		GTM muxed output
	—	O2		Reserved
	QSPI2_SLSO11	O3		Master slave select output
	—	O4		Reserved
	—	O5		Reserved
	—	O6		Reserved
	CCU60_COUT62	O7		T12 PWM channel 62
	IOM_MON1_5	O		Monitor input 1
	IOM_REF1_1			Reference input 1
	CBS_TGO7	O	Trigger output	

TC37xEXT Pin Definition and Functions LFBGA-292 Package Pinning of

Table 2-16 Port 34 Functions

Ball	Symbol	Ctrl.	Buffer Type	Function
U11	P34.1	I	SLOW / PU1 / VEVR SB / ES5	General-purpose input
	GTM_TIM5_IN3_9			Mux input channel 3 of TIM module 5
	GTM_TIM3_IN4_12			Mux input channel 4 of TIM module 3
	GTM_TIM2_IN3_9			Mux input channel 3 of TIM module 2
	EVADC_G10CH11	AI		Analog input channel 11, group 10
	P34.1	O0		General-purpose output
	GTM_TOUT146	O1		GTM muxed output
	ASCLIN4_ATX	O2		Transmit output
	—	O3		Reserved
	CAN00_TXD	O4		CAN transmit output node 0
	IOM_MON2_5			Monitor input 2
	IOM_REF2_5			Reference input 2
	CAN20_TXD	O5		CAN transmit output node 0
	—	O6		Reserved
	CCU60_COUT63	O7		T13 PWM channel 63
	IOM_MON1_6			Monitor input 1
IOM_REF1_0		Reference input 1		
T12	P34.2	I	SLOW / PU1 / VEVR SB / ES	General-purpose input
	GTM_TIM5_IN4_9			Mux input channel 4 of TIM module 5
	GTM_TIM3_IN5_13			Mux input channel 5 of TIM module 3
	GTM_TIM2_IN4_8			Mux input channel 4 of TIM module 2
	ASCLIN4_ARXB			Receive input
	CAN00_RXDG			CAN receive input node 0
	CAN20_RXDC			CAN receive input node 0
	EVADC_G10CH10	AI		Analog input channel 10, group 10
	P34.2	O0		General-purpose output
	GTM_TOUT147	O1		GTM muxed output
	—	O2		Reserved
	—	O3		Reserved
	—	O4		Reserved
	—	O5		Reserved
	—	O6		Reserved
	CCU60_CC60	O7		T12 PWM channel 60
IOM_MON1_2		Monitor input 1		
IOM_REF1_6		Reference input 1		

TC37xEXT Pin Definition and Functions LFBGA-292 Package Pinning of

Table 2-16 Port 34 Functions (cont'd)

Ball	Symbol	Ctrl.	Buffer Type	Function
U12	P34.3	I	SLOW / PU1 / VEVRSB / ES	General-purpose input
	GTM_TIM5_IN5_10			Mux input channel 5 of TIM module 5
	GTM_TIM3_IN6_13			Mux input channel 6 of TIM module 3
	GTM_TIM2_IN5_9			Mux input channel 5 of TIM module 2
	EVADC_G10CH9	AI		Analog input channel 9, group 10
	P34.3	O0		General-purpose output
	GTM_TOUT148	O1		GTM muxed output
	ASCLIN4_ASCLK	O2		Shift clock output
	—	O3		Reserved
	QSPI2_SLSO10	O4		Master slave select output
	—	O5		Reserved
	—	O6		Reserved
	CCU60_COUT60	O7		T12 PWM channel 60
	IOM_MON1_3			Monitor input 1
IOM_REF1_3	Reference input 1			
T13	P34.4	I	SLOW / PU1 / VEVRSB / ES	General-purpose input
	GTM_TIM5_IN6_10			Mux input channel 6 of TIM module 5
	GTM_TIM3_IN7_12			Mux input channel 7 of TIM module 3
	GTM_TIM2_IN6_8			Mux input channel 6 of TIM module 2
	QSPI2_MRSTD			Master SPI data input
	EVADC_G10CH8	AI		Analog input channel 8, group 10
	P34.4	O0		General-purpose output
	GTM_TOUT149	O1		GTM muxed output
	ASCLIN4_ASLSO	O2		Slave select signal output
	—	O3		Reserved
	QSPI2_MRST	O4		Slave SPI data output
	IOM_MON2_2			Monitor input 2
	IOM_REF2_2			Reference input 2
	—	O5		Reserved
	—	O6		Reserved
	CCU60_CC61	O7		T12 PWM channel 61
	IOM_MON1_1			Monitor input 1
IOM_REF1_5	Reference input 1			

TC37xEXT Pin Definition and Functions LFBGA-292 Package Pinning of

Table 2-16 Port 34 Functions (cont'd)

Ball	Symbol	Ctrl.	Buffer Type	Function
U13	P34.5	I	FAST / PU1 / VEVRSB / ES	General-purpose input
	GTM_TIM5_IN7_9			Mux input channel 7 of TIM module 5
	GTM_TIM4_IN7_12			Mux input channel 7 of TIM module 4
	GTM_TIM2_IN7_9			Mux input channel 7 of TIM module 2
	QSPI2_MTSRD			Slave SPI data input
	ASCLIN8_ARXE			Receive input
	P34.5	O0		General-purpose output
	GTM_TOUT150	O1		GTM muxed output
	ASCLIN8_ATX	O2		Transmit output
	—	O3		Reserved
	QSPI2_MTSR	O4		Master SPI data output
	—	O5		Reserved
	—	O6		Reserved
	CCU60_COUT61	O7		T12 PWM channel 61
	IOM_MON1_4			Monitor input 1
IOM_REF1_2		Reference input 1		

Table 2-17 Analog Inputs

Ball	Symbol	Ctrl.	Buffer Type	Function
T10	AN0	I	D / HighZ / VDDM	Analog Input 0
	EVADC_G0CH0			Analog input channel 0, group 0
	EDSADC_EDS3PA			Positive analog input channel 3, pin A
U10	AN1	I	D / HighZ / VDDM	Analog Input 1
	EVADC_G0CH1			Analog input channel 1, group 0
	EDSADC_EDS3NA			Negative analog input channel 3, pin A
W9	AN2	I	D / HighZ / VDDM	Analog Input 2
	EVADC_G0CH2			Analog input channel 2, group 0
	EDSADC_EDS0PA			Positive analog input channel 0, pin A
U9	AN3	I	D / HighZ / VDDM	Analog Input 3
	EVADC_G0CH3			Analog input channel 3, group 0
	EDSADC_EDS0NA			Negative analog input channel 0, pin A
T9	AN4	I	D / HighZ / VDDM	Analog Input 4
	EVADC_G11CH0			Analog input channel 0, group 11
	EVADC_G0CH4			Analog input channel 4, group 0
Y9	AN5	I	D / HighZ / VDDM	Analog Input 5
	EVADC_G11CH1			Analog input channel 1, group 11
	EVADC_G0CH5			Analog input channel 5, group 0

TC37xEXT Pin Definition and Functions LFBGA-292 Package Pinning of

Table 2-17 Analog Inputs (cont'd)

Ball	Symbol	Ctrl.	Buffer Type	Function
T8	AN6	I	D / HighZ / VDDM	Analog Input 6
	EVADC_G11CH2			Analog input channel 2, group 11
	EVADC_G0CH6			Analog input channel 6, group 0
U8	AN7	I	D / HighZ / VDDM	Analog Input 7
	EVADC_G11CH3			Analog input channel 3, group 11
	EVADC_G0CH7			Analog input channel 7, group 0
W8	AN8	I	D / HighZ / VDDM	Analog Input 8
	EVADC_G11CH4			Analog input channel 4, group 11
	EVADC_G1CH0			Analog input channel 0, group 1
U7	AN9	I	D / HighZ / VDDM	Analog Input 9
	EVADC_G11CH5			Analog input channel 5, group 11
	EVADC_G1CH1			Analog input channel 1, group 1
Y8	AN10	I	D / HighZ / VDDM	Analog Input 10
	EVADC_G11CH6			Analog input channel 6, group 11
	EVADC_G1CH2			Analog input channel 2, group 1
W7	AN11	I	D / HighZ / VDDM	Analog Input 11
	EVADC_G11CH7			Analog input channel 7, group 11
	EVADC_G1CH3			Analog input channel 3, group 1
T7	AN12	I	D / HighZ / VDDM	Analog Input 12
	EVADC_G1CH4			Analog input channel 4, group 1
	EDSADC_EDS0PB			Positive analog input channel 0, pin B
W6	AN13	I	D / HighZ / VDDM	Analog Input 13
	EVADC_G1CH5			Analog input channel 5, group 1
	EDSADC_EDS0NB			Negative analog input channel 0, pin B
U6	AN14	I	D / HighZ / VDDM	Analog Input 14
	EVADC_G1CH6			Analog input channel 6, group 1
	EDSADC_EDS3PB			Positive analog input channel 3, pin B
T6	AN15	I	D / HighZ / VDDM	Analog Input 15
	EVADC_G1CH7			Analog input channel 7, group 1
	EDSADC_EDS3NB			Negative analog input channel 3, pin N
W5	AN16	I	D / HighZ / VDDM	Analog Input 16
	EVADC_G2CH0			Analog input channel 0, group 2
	EVADC_FC0CH0			Analog input FC channel 0
U5	AN17/P40.10	I	S / HighZ / VDDM	Analog Input 17
	SENT_SENT10A			Receive input channel 10
	EVADC_G2CH1			Analog input channel 1, group 2
	EVADC_FC1CH0			Analog input FC channel 1

TC37xEXT Pin Definition and Functions LFBGA-292 Package Pinning of

Table 2-17 Analog Inputs (cont'd)

Ball	Symbol	Ctrl.	Buffer Type	Function
W4	AN18/P40.11	I	S / HighZ / VDDM	Analog Input 18
	SENT_SENT11A			Receive input channel 11
	EVADC_G11CH8			Analog input channel 8, group 11
	EVADC_G2CH2			Analog input channel 2, group 2
W3	AN19/P40.12	I	S / HighZ / VDDM	Analog Input 19
	SENT_SENT12A			Receive input channel 12
	EVADC_G11CH9			Analog input channel 9, group 11
	EVADC_G2CH3			Analog input channel 3, group 2
Y3	AN20	I	D / HighZ / VDDM	Analog Input 20
	EVADC_G2CH4			Analog input channel 4, group 2
	EDSADC_EDS2PA			Positive analog input channel 2, pin A
Y2	AN21	I	D / HighZ / VDDM	Analog Input 21
	EVADC_G2CH5			Analog input channel 5, group 2
	EDSADC_EDS2NA			Negative analog input channel 2, pin A
T5	AN22	I	D / HighZ / VDDM	Analog Input 22
	EVADC_G2CH6			Analog input channel 6, group 2
R5	AN23	I	D / HighZ / VDDM	Analog Input 23
	EVADC_G2CH7			Analog input channel 7, group 2
W2	AN24/P40.0	I	S / HighZ / VDDM	Analog Input 24
	SENT_SENT0A			Receive input channel 0
	EVADC_G3CH0			Analog input channel 0, group 3
	CCU60_CCPOS0D			Hall capture input 0
	EDSADC_EDS2PB			Positive analog input channel 2, pin B
W1	AN25/P40.1	I	S / HighZ / VDDM	Analog Input 25
	SENT_SENT1A			Receive input channel 1
	EVADC_G3CH1			Analog input channel 1, group 3
	CCU60_CCPOS1B			Hall capture input 1
	EDSADC_EDS2NB			Negative analog input channel 2, pin B
V2	AN26/P40.2	I	S / HighZ / VDDM	Analog Input 26
	SENT_SENT2A			Receive input channel 2
	EVADC_G3CH2			Analog input channel 2, group 3
	CCU60_CCPOS1D			Hall capture input 1
	EVADC_G11CH10			Analog input channel 10, group 11
V1	AN27/P40.3	I	S / HighZ / VDDM	Analog Input 27
	SENT_SENT3A			Receive input channel 3
	EVADC_G3CH3			Analog input channel 3, group 3
	CCU60_CCPOS2B			Hall capture input 2
	EVADC_G11CH11			Analog input channel 11, group 11

TC37xEXT Pin Definition and Functions LFBGA-292 Package Pinning of

Table 2-17 Analog Inputs (cont'd)

Ball	Symbol	Ctrl.	Buffer Type	Function
U2	AN28/P40.13	I	S / HighZ / VDDM	Analog Input 28
	SENT_SENT13A			Receive input channel 13
	EVADC_G3CH4			Analog input channel 4, group 3
U1	AN29/P40.14	I	S / HighZ / VDDM	Analog Input 29
	SENT_SENT14A			Receive input channel 14
	EVADC_G3CH5			Analog input channel 5, group 3
T4	AN30	I	D / HighZ / VDDM	Analog Input 30
	EVADC_G3CH6			Analog input channel 6, group 3
R4	AN31	I	D / HighZ / VDDM	Analog Input 31
	EVADC_G3CH7			Analog input channel 7, group 3
P4	AN32/P40.4	I	S / HighZ / VDDM	Analog Input 32
	SENT_SENT4A			Receive input channel 4
	EVADC_G8CH0			Analog input channel 0, group 8
	CCU60_CCPOS2D			Hall capture input 2
	EVADC_G11CH12			Analog input channel 12, group 11
R1	AN33/P40.5	I	S / HighZ / VDDM	Analog Input 33
	SENT_SENT5A			Receive input channel 5
	EVADC_G8CH1			Analog input channel 1, group 8
	CCU61_CCPOS0D			Hall capture input 0
	EVADC_G11CH13			Analog input channel 13, group 11
P5	AN34	I	D / HighZ / VDDM	Analog Input 34
	EVADC_G8CH2			Analog input channel 2, group 8
	EVADC_G11CH14			Analog input channel 14, group 11
R2	AN35	I	D / HighZ / VDDM	Analog Input 35
	EVADC_G8CH3			Analog input channel 3, group 8
	EVADC_G11CH15			Analog input channel 15, group 11
N4	AN36/P40.6	I	S / HighZ / VDDM	Analog Input 36
	SENT_SENT6A			Receive input channel 6
	EVADC_G8CH4			Analog input channel 4, group 8
	CCU61_CCPOS1B			Hall capture input 1
	EDSADC_EDS1PA			Positive analog input channel 1, pin A
P2	AN37/P40.7	I	S / HighZ / VDDM	Analog Input 37
	SENT_SENT7A			Receive input channel 7
	EVADC_G8CH5			Analog input channel 5, group 8
	CCU61_CCPOS1D			Hall capture input 1
	EDSADC_EDS1NA			Negative analog input channel 1, pin A

TC37xEXT Pin Definition and Functions LFBGA-292 Package Pinning of

Table 2-17 Analog Inputs (cont'd)

Ball	Symbol	Ctrl.	Buffer Type	Function
N5	AN38/P40.8	I	S / HighZ / VDDM	Analog Input 38
	SENT_SENT8A			Receive input channel 8
	EVADC_G8CH6			Analog input channel 6, group 8
	CCU61_CCPOS2B			Hall capture input 2
	EDSADC_EDS1PB			Positive analog input channel 1, pin B
P1	AN39/P40.9	I	S / HighZ / VDDM	Analog Input 39
	SENT_SENT9A			Receive input channel 9
	EVADC_G8CH7			Analog input channel 7, group 8
	CCU61_CCPOS2D			Hall capture input 2
	EDSADC_EDS1NB			Negative analog input channel 1, pin B
M5	AN40	I	D / HighZ / VDDM	Analog Input 40
	EVADC_G8CH8			Analog input channel 8, group 8
M4	AN41	I	D / HighZ / VDDM	Analog Input 41
	EVADC_G8CH9			Analog input channel 9, group 8
L5	AN42	I	D / HighZ / VDDM	Analog Input 42
	EVADC_G8CH10			Analog input channel 10, group 8
L4	AN43	I	D / HighZ / VDDM	Analog Input 43
	EVADC_G8CH11			Analog input channel 11, group 8
N1	AN44	I	D / HighZ / VDDM	Analog Input 44
	EVADC_G8CH12			Analog input channel 12, group 8
	EDSADC_EDS1PC			Positive analog input channel 1, pin C
N2	AN45	I	D / HighZ / VDDM	Analog Input 45
	EVADC_G8CH13			Analog input channel 13, group 8
	EDSADC_EDS1NC			Negative analog input channel 1, pin C
M1	AN46	I	D / HighZ / VDDM	Analog Input 46
	EVADC_G8CH14			Analog input channel 14, group 8
	EDSADC_EDS1PD			Positive analog input channel 1, pin D
M2	AN47	I	D / HighZ / VDDM	Analog Input 47
	EVADC_G8CH15			Analog input channel 15, group 8
	EDSADC_EDS1ND			Negative analog input channel 1, pin D

TC37xEXT Pin Definition and Functions LFBGA-292 Package Pinning of

Table 2-18 System I/O

Ball	Symbol	Ctrl.	Buffer Type	Function
L7	AGBTCLKN (VSS)	I	AGBT_C LK / VEXT	Input PAD (negative pole) for the external 100 MHz differential clock. AGBT Input; (TC3xx devices without AGBT: VSS)
K7	AGBTCLKP (VSS)	I	AGBT_C LK / VEXT	Input PAD (positive pole) for the external 100 MHz differential clock. AGBT Input; (TC3xx devices without AGBT: VSS)
P10	AGBTTXN (VSS)	O	AGBT_T X / VEXT	Off-chip driver output PAD of the 2.5Gbps transmitter, negative pole AGBT Output; (TC3xx devices without AGBT: VSS)
P11	AGBTTXP (VSS)	O	AGBT_T X / VEXT	Off-chip driver output PAD of the 2.5Gbps transmitter, positive pole AGBT Output; (TC3xx devices without AGBT: VSS)
L14	AGBTERR (VSS)	I	FAST / PD / VEXT	Input PAD for CRC error from FPGA. AGBT Input; (TC3xx devices without AGBT: VSS)
Y17	VGATE1N	O	—	DCDC N ch. MOSFET gate driver output P32.0 / SMPS mode: analog output. External Pass Device gate control for EVRC
W17	VGATE1P	O	—	DCDC P ch. MOSFET gate driver output P32.1 / External Pass Device gate control for EVRC
M20	XTAL1	I	XTAL / VEXT	XTAL pad1 XTAL1. Main Oscillator/PLL/Clock Generator Input.
M19	XTAL2	O	XTAL / VEXT	XTAL pad2 XTAL2. Main Oscillator/PLL/Clock Generator OUTPUT
G10	DAPE2	I/O	FAST / PD2 / VEXT	DAPE: DAPE2 Data I/O DAPE: DAPE2 Data I/O (TC3xx devices without DAPE: VSS)
G11	DAPE1	I/O	FAST / PD2 / VEXT	DAPE: DAPE1 Data I/O DAPE: DAPE1 Data I/O (TC3xx devices without DAPE: VSS)
K16	TMS	I	FAST / PD2 / VEXT	JTAG Module State Machine Control Input TMS: JTAG Module State Machine Control Input. DAP: DAP1 Data I/O.
	DAP1	I/O		DAP: DAP1 Data I/O
K14	DAPE0	I	FAST / PD2 / VEXT	DAPE: DAPE0 Clock Input DAPE: DAPE0 clock input (TC3xx devices without DAPE: NC)
L19	$\overline{\text{TRST}}$	I	FAST / PU2 / VEXT	JTAG Module Reset/Enable Input TRST_N: JTAG Module Reset/Enable Input. DAPE: DAPE0 Clock Input
	DAPE0	I		DAPE: DAPE0 Clock Input

TC37xEXT Pin Definition and Functions LFBGA-292 Package Pinning of

Table 2-18 System I/O (cont'd)

Ball	Symbol	Ctrl.	Buffer Type	Function
J16	TCK	I	FAST / PD2 / VEXT	JTAG Module Clock Input TCK: JTAG Module Clock Input. DAP: DAP0 Clock Input.
	DAP0	I	VEXT	DAP: DAP0 Clock Input
G16	$\overline{\text{ESR1}}$	I	FAST / PU1 / VEXT	ESR1 Port Pin input - can be used to trigger a reset or an NMI ESR1: External System Request Reset 1. Default NMI function. See also SCU chapter for details. Default after power-on can be different. See also SCU chapter 'Reset Control Unit' and SCU_IOCRR register description. PMS_EVRWUP: EVR Wakeup Pin
	PMS_ESR1WKP	I		ESR1 pin input
G17	$\overline{\text{PORST}}$	I/O	PORST / PD / VEXT	PORST pin Power On Reset Input. Additional strong PD in case of power fail.
F16	$\overline{\text{ESR0}}$	I	FAST / OD / VEXT	ESR0 Port Pin input - can be used to trigger a reset or an NMI ESR0: External System Request Reset 0. Default configuration during and after reset is open-drain driver. The driver drives low during power-on reset. This is valid additionally after deactivation of PORST_N until the internal reset phase has finished. See also SCU chapter for details. Default after power-on can be different. See also SCU chapter 'Reset Control Unit' and SCU_IOCRR register description. PMS_EVRWUP: EVR Wakeup Pin
	PMS_ESR0WKP	I		ESR0 pin input

Table 2-19 Supply

Ball	Symbol	Ctrl.	Buffer Type	Function
P8, P13, N7, N14, E15, H14, D16, G13	VDD	I	—	Digital Core Power Supply (1.25V)
A2, B3, V19, W20	VEXT	I	—	External Power Supply (5V / 3.3V)
D5	VFLEX	I	—	Digital Power Supply for Flex Port Pads (5V / 3.3V)
Y5	VDDM	I	—	ADC Analog Power Supply (5V / 3.3V)
B18, A19	VDDP3	I	—	Flash Power Supply (3.3V)
B2, D4, E5, T16, U17, W19, Y20, E16, D17, B19, A20	VSS	I	—	Digital Ground

TC37xEXT Pin Definition and Functions LFBGA-292 Package Pinning of

Table 2-19 Supply (cont'd)

Ball	Symbol	Ctrl.	Buffer Type	Function
Y4	VSSM	I	—	Analog Ground for VDDM
P9, P12, N9, N10, N11, N12, M7, M8, M10, M11, M13, M14, L8, L9, L10, L11, L12, L13, K8, K9, K10, K11, K12, K13, J7, J8, J10, J11, J13, J14, H9, H10, H11, H12, G9, G12	VSS	I	—	Digital Ground
L20	VSS	I	—	Oscillator Ground, VSS(OSC)
Y6	VAREF1	I	—	Positive Analog Reference Voltage 1
Y7	VAGND1	I	—	Negative Analog Reference Voltage 1
T1	VAREF2	I	—	Positive Analog Reference Voltage 2
T2	VAGND2	I	—	Negative Analog Reference Voltage 2
A1, Y1, U4	NC1	I	—	Not connected. These pins are not connected on package level and will not be used for future extensions
G8, H7	VDDSB (VDD)	I	—	Devices with integrated EMEM: EMEM SRAM Standby Power Supply, VDDSB (1.25V); Devices without integrated EMEM: VDD (1.25V)
T11	VEVRSB	I	—	Standby Power Supply (5V / 3.3V) for the Standby SRAM
N19	VDD	I	—	Digital Power Supply for Oscillator (1.25V), VDD(OSC)
N20	VEXT	I	—	Digital Power Supply for Oscillator (shall be supplied with same level as used for VEXT), VEXT(OSC)

TC37xEXT Pin Definition and Functions LFBGA-292 Package Pinning of

2.2 LFBGA-292 Package Pinning of TC37xEXT TX

	1	2	3	4	5	6	7	8	9	10	11	12	13	14	15	16	17	18	19	20			
A	NC1	VEXT	P10.7	P10.6	P10.2	P10.3	P10.0	P11.11	P11.9	P11.2	P13.3	P13.1	P14.8	P14.5	P14.1	P15.6	P15.4	P15.1	VDDP3	VSS	A		
B	P02.0	VSS	VEXT	P10.8	P10.5	P10.4	P10.1	P11.12	P11.10	P11.3	P13.2	P13.0	P14.6	P14.3	P14.4	P14.0	P15.3	VDDP3	VSS	P15.0	B		
C	P02.2	P02.1																	P15.2	P20.14	C		
D	P02.4	P02.3	VSS	VFLEX	P11.15	P11.14	P11.5	P11.6	P11.4	P14.10	P14.9	P14.7	P15.8	P15.7	VDD	VSS			P20.12	P20.13	D		
E	P02.6	P02.5	P02.9	VSS	P11.13	P11.8	P11.7	P11.1	P11.0	P12.1	P12.0	P14.2	P15.5	VDD	VSS	P20.9			P20.10	P20.11	E		
F	P02.8	P02.7	P02.11	P02.10											ESR0	P20.6			P20.7	P20.8	F		
G	P00.0	P00.1	P01.4	P01.3			VDDSB (VDD)	VSS	DAPE2	DAPE1	VSS	VDD			ESR1	FORST			P20.1	P20.3	G		
H	P00.2	P00.3	P01.6	P01.5			VDDSB (VDD)	VSS	VSS	VSS	VSS	VSS	VDD			P21.7 / TDO	P21.6 / TDI			P20.2	P20.0	H	
J	P00.4	P00.5	P00.6	P01.7			VSS	VSS	VSS	VSS	VSS	VSS	VSS			TCK	P21.1			P21.3	P21.5	J	
K	P00.7	P00.9	P00.8	P00.10			AGBTC LKP (VSS)	VSS	VSS	VSS	VSS	VSS	VSS	DAPE0			TMS	P21.0			P21.2	P21.4	K
L	P00.11	P00.12	AN43	AN42			AGBTC LKN (VSS)	VSS	VSS	VSS	VSS	VSS	VSS	AGBTE RR (VSS)			P22.0	P22.1			TRST	VSS	L
M	AN46	AN47	AN41	AN40			VSS	VSS	VSS	VSS	VSS	VSS	VSS			P22.8	P22.9			XTAL2	XTAL1	M	
N	AN44	AN45	AN36 / P40.6	AN38 / P40.8			VDD	VSS	VSS	VSS	VSS	VSS	VSS	VDD			P22.6	P22.7			VDD	VEXT	N
P	AN39 / P40.9	AN37 / P40.7	AN32 / P40.4	AN34			VDD	VSS	AGBTT XN (VSS)	AGBTT XP (VSS)	VSS	VDD			P22.4	P22.5			P22.11	P22.10	P		
R	AN33 / P40.5	AN35	AN31	AN23													P23.7	P23.6			P22.3	P22.2	R
T	VAREF 2	VAGND 2	AN30	AN22	AN15	AN12	AN6	AN4	AN0	VEVRS B	P34.2	P34.4	P33.14	P32.5	VSS	P23.5			P22.12	P23.4	T		
U	AN29 / P40.14	AN28 / P40.13	NC1	AN17 / P40.10	AN14	AN9	AN7	AN3	AN1	P34.1	P34.3	P34.5	P33.15	P32.6	P32.7	VSS			P23.1	P23.3	U		
V	AN27 / P40.3	AN26 / P40.2																	VFLEX 2	P23.2	V		
W	AN25 / P40.1	AN24 / P40.0	AN19 / P40.12	AN18 / P40.11	AN16	AN13	AN11	AN8	AN2	P33.0	P33.2	P33.4	P33.6	P33.8	P33.10	P33.12	P32.1 / VGATE 1P	P32.4	VSS	VEXT	W		
Y	NC1	AN21	AN20	VSSM	VDDM	VAREF 1	VAGND 1	AN10	AN5	P33.1	P33.3	P33.5	P33.7	P33.9	P33.11	P33.13	P32.0 / VGATE 1N	P32.2	P32.3	VSS	Y		

TC37xed_geth - (top view)

Figure 2-2 TC37xEXT TX package variant LFBGA-292

TC37xEXT Pin Definition and Functions LFBGA-292 Package Pinning of

Table 2-20 Port 00 Functions

Ball	Symbol	Ctrl.	Buffer Type	Function
G1	P00.0	I	FAST / PU1 / VEXT / ES	General-purpose input
	GTM_TIM5_IN4_10			Mux input channel 4 of TIM module 5
	GTM_TIM3_IN0_1			Mux input channel 0 of TIM module 3
	GTM_TIM2_IN0_1			Mux input channel 0 of TIM module 2
	CCU61_CTRAPA			Trap input capture
	CCU60_T12HRE			External timer start 12
	MSC0_INJ0			Injection signal from port
	CIF_D9			sensor pixel data input
	GETH_MDIOA			MDIO Input
	P00.0			O0
	GTM_TOUT9	O1	GTM muxed output	
	IOM_REF0_9	O2	Reference input 0	
	ASCLIN3_ASCLK		Shift clock output	
	ASCLIN3_ATX		O3	Transmit output
	IOM_MON2_15	O3	Monitor input 2	
	IOM_REF2_15		Reference input 2	
	—	O4	Reserved	
	CAN10_TXD	O5	CAN transmit output node 0	
	—	O6	Reserved	
	CCU60_COUT63	O7	T13 PWM channel 63	
IOM_MON1_6	O7	Monitor input 1		
IOM_REF1_0		Reference input 1		
GETH_MDIO		O	MDIO Output	

TC37xEXT Pin Definition and Functions LFBGA-292 Package Pinning of

Table 2-20 Port 00 Functions (cont'd)

Ball	Symbol	Ctrl.	Buffer Type	Function	
G2	P00.1	I	SLOW / PU1 / VEXT / ES	General-purpose input	
	GTM_TIM5_IN5_11			Mux input channel 5 of TIM module 5	
	GTM_TIM3_IN1_1			Mux input channel 1 of TIM module 3	
	GTM_TIM2_IN1_1			Mux input channel 1 of TIM module 2	
	CCU60_CC60INB			T12 capture input 60	
	ASCLIN3_ARXE			Receive input	
	EDSADC_DSCIN5A			Modulator clock input, channel 5	
	CAN10_RXDA			CAN receive input node 0	
	PSI5_RX0A			RXD inputs (receive data) channel 0	
	CIF_D10			sensor pixel data input	
	CCU61_CC60INA			T12 capture input 60	
	SENT_SENT0B			Receive input channel 0	
	EVADC_G9CH11			AI	Analog input channel 11, group 9
	EDSADC_EDS5NA				Negative analog input channel 5, pin A
	P00.1	O0	General-purpose output		
	GTM_TOUT10	O1	GTM muxed output		
	IOM_REF0_10		Reference input 0		
	ASCLIN3_ATX	O2	Transmit output		
	IOM_MON2_15		Monitor input 2		
	IOM_REF2_15		Reference input 2		
	—	O3	Reserved		
	EDSADC_DSCOUT5	O4	Modulator clock output		
	—	O5	Reserved		
	SENT_SPC0	O6	Transmit output		
	CCU61_CC60	O7	T12 PWM channel 60		
	IOM_MON1_8		Monitor input 1		
IOM_REF1_13		Reference input 1			

TC37xEXT Pin Definition and Functions LFBGA-292 Package Pinning of

Table 2-20 Port 00 Functions (cont'd)

Ball	Symbol	Ctrl.	Buffer Type	Function
H1	P00.2	I	SLOW / PU1 / VEXT / ES1	General-purpose input
	GTM_TIM5_IN6_11			Mux input channel 6 of TIM module 5
	GTM_TIM3_IN1_2			Mux input channel 1 of TIM module 3
	GTM_TIM2_IN1_2			Mux input channel 1 of TIM module 2
	EDSADC_DSDIN5A			Digital datastream input, channel 5
	SENT_SENT1B			Receive input channel 1
	CIF_D11			sensor pixel data input
	EVADC_G9CH10	AI	Analog input channel 10, group 9	
	EDSADC_EDS5PA		Positive analog input channel 5, pin A	
	P00.2	O0	General-purpose output	
	GTM_TOUT11	O1	GTM muxed output	
	IOM_REF0_11		Reference input 0	
	ASCLIN3_ASCLK	O2	Shift clock output	
	CAN21_TXD	O3	CAN transmit output node 1	
	PSI5_TX0	O4	TXD outputs (send data)	
	IOM_MON1_14		Monitor input 1	
	IOM_REF1_14		Reference input 1	
	CAN03_TXD		O5	CAN transmit output node 3
	IOM_MON2_8		Monitor input 2	
	IOM_REF2_8		Reference input 2	
	QSPI3_SLSO4	O6	Master slave select output	
	CCU61_COUT60	O7	T12 PWM channel 60	
	IOM_MON1_11		Monitor input 1	
IOM_REF1_10	Reference input 1			

TC37xEXT Pin Definition and Functions LFBGA-292 Package Pinning of

Table 2-20 Port 00 Functions (cont'd)

Ball	Symbol	Ctrl.	Buffer Type	Function
H2	P00.3	I	SLOW / PU1 / VEXT / ES1	General-purpose input
	GTM_TIM5_IN7_10			Mux input channel 7 of TIM module 5
	GTM_TIM3_IN2_1			Mux input channel 2 of TIM module 3
	GTM_TIM2_IN2_1			Mux input channel 2 of TIM module 2
	CCU60_CC61INB			T12 capture input 61
	EDSADC_DSCIN3A			Modulator clock input, channel 3
	EDSADC_ITR5F			Trigger/Gate input, channel 5
	PSI5_RX1A			RXD inputs (receive data) channel 1
	CAN03_RXDA			CAN receive input node 3
	CAN21_RXDA			CAN receive input node 1
	PSI5S_RXA			RX data input
	SENT_SENT2B			Receive input channel 2
	CIF_D12			sensor pixel data input
	CCU61_CC61INA			T12 capture input 61
	EVADC_G9CH9	AI	Analog input channel 9, group 9	
	EDSADC_EDS5NB		Negative analog input channel 5, pin B	
	P00.3	O0	General-purpose output	
	GTM_TOUT12	O1	GTM muxed output	
	IOM_REF0_12		Reference input 0	
	ASCLIN3_ASLSO	O2	Slave select signal output	
—	O3	Reserved		
EDSADC_DSCOUT3	O4	Modulator clock output		
—	O5	Reserved		
SENT_SPC2	O6	Transmit output		
CCU61_CC61	O7	T12 PWM channel 61		
IOM_MON1_9		Monitor input 1		
IOM_REF1_12		Reference input 1		

TC37xEXT Pin Definition and Functions LFBGA-292 Package Pinning of

Table 2-20 Port 00 Functions (cont'd)

Ball	Symbol	Ctrl.	Buffer Type	Function	
J1	P00.4	I	SLOW / PU1 / VEXT / ES1	General-purpose input	
	GTM_TIM3_IN3_1			Mux input channel 3 of TIM module 3	
	GTM_TIM2_IN3_1			Mux input channel 3 of TIM module 2	
	SCU_E_REQ2_2			ERU Channel 2 inputs 0 to 5 (0 is the LSB and 5 is the MSB)	
	SENT_SENT3B			Receive input channel 3	
	EDSADC_DSDIN3A			Digital datastream input, channel 3	
	EDSADC_SGNA			Carrier sign signal input	
	ASCLIN10_ARXA			Receive input	
	CIF_D13			sensor pixel data input	
	EVADC_G9CH8			AI	Analog input channel 8, group 9
	EDSADC_EDS5PB				Positive analog input channel 5, pin B
	P00.4			O0	General-purpose output
	GTM_TOUT13			O1	GTM muxed output
	IOM_REF0_13		Reference input 0		
	PSI5S_TX	O2	TX data output		
	CAN11_TXD	O3	CAN transmit output node 1		
	PSI5_TX1	O4	TXD outputs (send data)		
	IOM_MON1_15		Monitor input 1		
	—	O5	Reserved		
	SENT_SPC3	O6	Transmit output		
	CCU61_COUT61	O7	T12 PWM channel 61		
	IOM_MON1_12		Monitor input 1		
	IOM_REF1_9		Reference input 1		

TC37xEXT Pin Definition and Functions LFBGA-292 Package Pinning of

Table 2-20 Port 00 Functions (cont'd)

Ball	Symbol	Ctrl.	Buffer Type	Function	
J2	P00.5	I	SLOW / PU1 / VEXT / ES1	General-purpose input	
	GTM_TIM3_IN4_1			Mux input channel 4 of TIM module 3	
	GTM_TIM3_IN0_11			Mux input channel 0 of TIM module 3	
	GTM_TIM2_IN4_1			Mux input channel 4 of TIM module 2	
	CCU60_CC62INB			T12 capture input 62	
	EDSADC_DSCIN2A			Modulator clock input, channel 2	
	CCU61_CC62INA			T12 capture input 62	
	SENT_SENT4B			Receive input channel 4	
	CIF_D14			sensor pixel data input	
	CAN11_RXDB			CAN receive input node 1	
	GTM_DTMT1_1			CDTM1_DTM0	
	EVADC_G9CH7			AI	Analog input channel 7, group 9
	P00.5			O0	General-purpose output
	GTM_TOUT14	O1	GTM muxed output		
	IOM_REF0_14		Reference input 0		
	EDSADC_CGPWMN	O2	Negative carrier generator output		
	QSPI3_SLSO3	O3	Master slave select output		
	EDSADC_DSCOUT2	O4	Modulator clock output		
	EVADC_FC0BFLOUT	O5	Boundary flag output, FC channel 0		
	SENT_SPC4	O6	Transmit output		
CCU61_CC62	O7	T12 PWM channel 62			
IOM_MON1_10		Monitor input 1			
IOM_REF1_11		Reference input 1			

TC37xEXT Pin Definition and Functions LFBGA-292 Package Pinning of

Table 2-20 Port 00 Functions (cont'd)

Ball	Symbol	Ctrl.	Buffer Type	Function
J4	P00.6	I	SLOW / PU1 / VEXT / ES1	General-purpose input
	GTM_TIM3_IN5_1			Mux input channel 5 of TIM module 3
	GTM_TIM3_IN1_14			Mux input channel 1 of TIM module 3
	GTM_TIM2_IN5_1			Mux input channel 5 of TIM module 2
	EDSADC_ITR4F			Trigger/Gate input, channel 4
	EDSADC_DSDIN2A			Digital datastream input, channel 2
	SENT_SENT5B			Receive input channel 5
	CIF_D15			sensor pixel data input
	ASCLIN5_ARXA			Receive input
	EVADC_G9CH6			AI
	P00.6	O0	General-purpose output	
	GTM_TOUT15	O1	GTM muxed output	
	IOM_REF0_15		Reference input 0	
	EDSADC_CGPWMP	O2	Positive carrier generator output	
	—	O3	Reserved	
	—	O4	Reserved	
	EVADC_EMUX10	O5	Control of external analog multiplexer interface 1	
	SENT_SPC5	O6	Transmit output	
	CCU61_COUT62	O7	T12 PWM channel 62	
	IOM_MON1_13		Monitor input 1	
IOM_REF1_8		Reference input 1		

TC37xEXT Pin Definition and Functions LFBGA-292 Package Pinning of

Table 2-20 Port 00 Functions (cont'd)

Ball	Symbol	Ctrl.	Buffer Type	Function
K1	P00.7	I	SLOW / PU1 / VEXT / ES1	General-purpose input
	GTM_TIM3_IN6_1			Mux input channel 6 of TIM module 3
	GTM_TIM3_IN2_11			Mux input channel 2 of TIM module 3
	GTM_TIM2_IN6_1			Mux input channel 6 of TIM module 2
	CCU61_CC60INC			T12 capture input 60
	SENT_SENT6B			Receive input channel 6
	EDSADC_DSCIN4A			Modulator clock input, channel 4
	GPT120_T2INA			Trigger/gate input of timer T2
	CCU61_CCPOS0A			Hall capture input 0
	CCU60_T12HRB			External timer start 12
	CIF_PCLK			Sensor Pixel Clock input
	GTM_DTMT0_2			CDTM0_DTM0
	EVADC_G9CH5			AI
	EDSADC_EDS4NA	Negative analog input channel 4, pin A		
	P00.7	O0	General-purpose output	
	GTM_TOUT16	O1	GTM muxed output	
	ASCLIN5_ATX	O2	Transmit output	
	EVADC_FC2BFLOUT	O3	Boundary flag output, FC channel 2	
	EDSADC_DSCOUT4	O4	Modulator clock output	
	EVADC_EMUX11	O5	Control of external analog multiplexer interface 1	
	SENT_SPC6	O6	Transmit output	
	CCU61_CC60	O7	T12 PWM channel 60	
	IOM_MON1_8		Monitor input 1	
IOM_REF1_13	Reference input 1			

TC37xEXT Pin Definition and Functions LFBGA-292 Package Pinning of

Table 2-20 Port 00 Functions (cont'd)

Ball	Symbol	Ctrl.	Buffer Type	Function
K4	P00.8	I	SLOW / PU1 / VEXT / ES1	General-purpose input
	GTM_TIM3_IN7_1			Mux input channel 7 of TIM module 3
	GTM_TIM3_IN3_11			Mux input channel 3 of TIM module 3
	GTM_TIM2_IN7_1			Mux input channel 7 of TIM module 2
	CCU61_CC61INC			T12 capture input 61
	SENT_SENT7B			Receive input channel 7
	EDSADC_DSDIN4A			Digital datastream input, channel 4
	GPT120_T2EUDA			Count direction control input of timer T2
	CCU61_CCPOS1A			Hall capture input 1
	CIF_VSYNC			vertical synchronization signal input
	CCU60_T13HRB			External timer start 13
	ASCLIN10_ARXB			Receive input
	EVADC_G9CH4			AI
	EDSADC_EDS4PA	Positive analog input channel 4, pin A		
	P00.8	O0	General-purpose output	
	GTM_TOUT17	O1	GTM muxed output	
	QSPI3_SLSO6	O2	Master slave select output	
	ASCLIN10_ATX	O3	Transmit output	
	—	O4	Reserved	
	EVADC_EMUX12	O5	Control of external analog multiplexer interface 1	
	SENT_SPC7	O6	Transmit output	
	CCU61_CC61	O7	T12 PWM channel 61	
	IOM_MON1_9		Monitor input 1	
IOM_REF1_12	Reference input 1			

TC37xEXT Pin Definition and Functions LFBGA-292 Package Pinning of

Table 2-20 Port 00 Functions (cont'd)

Ball	Symbol	Ctrl.	Buffer Type	Function	
K2	P00.9	I	SLOW / PU1 / VEXT / ES1	General-purpose input	
	GTM_TIM4_IN0_7			Mux input channel 0 of TIM module 4	
	GTM_TIM1_IN0_1			Mux input channel 0 of TIM module 1	
	GTM_TIM0_IN0_1			Mux input channel 0 of TIM module 0	
	CCU61_CC62INC			T12 capture input 62	
	SENT_SENT8B			Receive input channel 8	
	CCU61_CCPOS2A			Hall capture input 2	
	EDSADC_DSCIN1A			Modulator clock input, channel 1	
	EDSADC_ITR3F			Trigger/Gate input, channel 3	
	GPT120_T4EUDA			Count direction control input of timer T4	
	CCU60_T13HRC			External timer start 13	
	CIF_HSYNC			horizontal synchronization signal input	
	CCU60_T12HRC			External timer start 12	
	EVADC_G9CH3			AI	Analog input channel 3, group 9
	EDSADC_EDS4NB				Negative analog input channel 4, pin B
	P00.9	O0	General-purpose output		
	GTM_TOUT18	O1	GTM muxed output		
	QSPI3_SLSO7	O2	Master slave select output		
	ASCLIN3_ARTS	O3	Ready to send output		
	EDSADC_DSCOUT1	O4	Modulator clock output		
	ASCLIN4_ATX	O5	Transmit output		
	SENT_SPC8	O6	Transmit output		
	CCU61_CC62	O7	T12 PWM channel 62		
IOM_MON1_10		Monitor input 1			
IOM_REF1_11		Reference input 1			

TC37xEXT Pin Definition and Functions LFBGA-292 Package Pinning of

Table 2-20 Port 00 Functions (cont'd)

Ball	Symbol	Ctrl.	Buffer Type	Function
K5	P00.10	I	SLOW / PU1 / VEXT / ES1	General-purpose input
	GTM_TIM4_IN1_11			Mux input channel 1 of TIM module 4
	GTM_TIM1_IN1_1			Mux input channel 1 of TIM module 1
	GTM_TIM0_IN1_1			Mux input channel 1 of TIM module 0
	SENT_SENT9B			Receive input channel 9
	EDSADC_DSDIN1A			Digital datastream input, channel 1
	EVADC_G9CH2			Analog input channel 2, group 9
	EDSADC_EDS4PB	AI		Positive analog input channel 4, pin B
	P00.10			O0
	GTM_TOUT19	O1	GTM muxed output	
	ASCLIN4_ASCLK	O2	Shift clock output	
	—	O3	Reserved	
	—	O4	Reserved	
	—	O5	Reserved	
	SENT_SPC9	O6	Transmit output	
	CCU61_COUT63	O7	T13 PWM channel 63	
	IOM_MON1_7		Monitor input 1	
IOM_REF1_7	Reference input 1			
L1	P00.11	I	SLOW / PU1 / VEXT / ES1	General-purpose input
	GTM_TIM4_IN2_11			Mux input channel 2 of TIM module 4
	GTM_TIM1_IN2_1			Mux input channel 2 of TIM module 1
	GTM_TIM0_IN2_1			Mux input channel 2 of TIM module 0
	CCU60_CTRAPA			Trap input capture
	EDSADC_DSCIN0A			Modulator clock input, channel 0
	CCU61_T12HRE			External timer start 12
	SENT_SENT10B	Receive input channel 10		
	EVADC_G9CH1	AI		Analog input channel 1, group 9
	EVADC_FC3CH0			Analog input FC channel 3
	P00.11	O0	General-purpose output	
	GTM_TOUT20	O1	GTM muxed output	
	ASCLIN4_ASLSO	O2	Slave select signal output	
	—	O3	Reserved	
	EDSADC_DSCOUT0	O4	Modulator clock output	
	—	O5	Reserved	
	—	O6	Reserved	
—	O7	Reserved		

TC37xEXT Pin Definition and Functions LFBGA-292 Package Pinning of

Table 2-20 Port 00 Functions (cont'd)

Ball	Symbol	Ctrl.	Buffer Type	Function
L2	P00.12	I	SLOW / PU1 / VEXT / ES1	General-purpose input
	GTM_TIM4_IN3_11			Mux input channel 3 of TIM module 4
	GTM_TIM1_IN3_1			Mux input channel 3 of TIM module 1
	GTM_TIM0_IN3_1			Mux input channel 3 of TIM module 0
	ASCLIN3_ACTSA			Clear to send input
	EDSADC_DSDIN0A			Digital datastream input, channel 0
	ASCLIN4_ARXA			Receive input
	SENT_SENT11B			Receive input channel 11
	EVADC_G9CH0			AI
	EVADC_FC2CH0	Analog input FC channel 2		
	P00.12	O0	General-purpose output	
	GTM_TOUT21	O1	GTM muxed output	
	—	O2	Reserved	
	—	O3	Reserved	
	—	O4	Reserved	
	—	O5	Reserved	
	—	O6	Reserved	
	CCU61_COUT63	O7	T13 PWM channel 63	
	IOM_MON1_7		Monitor input 1	
	IOM_REF1_7		Reference input 1	

TC37xEXT Pin Definition and Functions LFBGA-292 Package Pinning of

Table 2-21 Port 01 Functions

Ball	Symbol	Ctrl.	Buffer Type	Function
G5	P01.3	I	SLOW / PU1 / VEXT / ES	General-purpose input
	GTM_TIM4_IN5_2			Mux input channel 5 of TIM module 4
	GTM_TIM2_IN0_14			Mux input channel 0 of TIM module 2
	GTM_TIM0_IN5_8			Mux input channel 5 of TIM module 0
	QSPI3_SLSIB			Slave select input
	EVADC_G9CH14	AI		Analog input channel 14, group 9
	P01.3	O0		General-purpose output
	GTM_TOUT111	O1		GTM muxed output
	—	O2		Reserved
	—	O3		Reserved
	QSPI3_SLSO9	O4		Master slave select output
	CAN01_TXD	O5		CAN transmit output node 1
	IOM_MON2_6	O6		Monitor input 2
	IOM_REF2_6			Reference input 2
	—			Reserved
—	O7	Reserved		
G4	P01.4	I	SLOW / PU1 / VEXT / ES	General-purpose input
	GTM_TIM4_IN6_2			Mux input channel 6 of TIM module 4
	GTM_TIM2_IN1_14			Mux input channel 1 of TIM module 2
	GTM_TIM0_IN6_8			Mux input channel 6 of TIM module 0
	CAN01_RXDC			CAN receive input node 1
	EVADC_G9CH13	AI		Analog input channel 13, group 9
	P01.4	O0		General-purpose output
	GTM_TOUT112	O1		GTM muxed output
	—	O2		Reserved
	ASCLIN9_ASLSO	O3		Slave select signal output
	QSPI3_SLSO10	O4		Master slave select output
	—	O5		Reserved
	—	O6		Reserved
	—	O7		Reserved

TC37xEXT Pin Definition and Functions LFBGA-292 Package Pinning of

Table 2-21 Port 01 Functions (cont'd)

Ball	Symbol	Ctrl.	Buffer Type	Function
H5	P01.5	I	SLOW / PU1 / VEXT / ES	General-purpose input
	GTM_TIM5_IN3_2			Mux input channel 3 of TIM module 5
	GTM_TIM2_IN3_7			Mux input channel 3 of TIM module 2
	GTM_TIM2_IN2_7			Mux input channel 2 of TIM module 2
	QSPI3_MRSTC			Master SPI data input
	ASCLIN9_ARXA			Receive input
	EVADC_G9CH12			AI
	P01.5	O0	General-purpose output	
	GTM_TOUT113	O1	GTM muxed output	
	—	O2	Reserved	
	—	O3	Reserved	
	QSPI3_MRST	O4	Slave SPI data output	
	IOM_MON2_3		Monitor input 2	
	IOM_REF2_3		Reference input 2	
	—	O5	Reserved	
	—	O6	Reserved	
	—	O7	Reserved	
H4	P01.6	I	FAST / PU1 / VEXT / ES	General-purpose input
	GTM_TIM5_IN6_2			Mux input channel 6 of TIM module 5
	GTM_TIM5_IN5_3			Mux input channel 5 of TIM module 5
	GTM_TIM2_IN5_7			Mux input channel 5 of TIM module 2
	QSPI3_MTSRC			Slave SPI data input
	P01.6	O0	General-purpose output	
	GTM_TOUT114	O1	GTM muxed output	
	—	O2	Reserved	
	ASCLIN9_ASCLK	O3	Shift clock output	
	QSPI3_MTSR	O4	Master SPI data output	
	—	O5	Reserved	
	—	O6	Reserved	
	—	O7	Reserved	

TC37xEXT Pin Definition and Functions LFBGA-292 Package Pinning of

Table 2-21 Port 01 Functions (cont'd)

Ball	Symbol	Ctrl.	Buffer Type	Function
J5	P01.7	I	FAST / PU1 / VEXT / ES	General-purpose input
	GTM_TIM5_IN7_2			Mux input channel 7 of TIM module 5
	GTM_TIM2_IN7_7			Mux input channel 7 of TIM module 2
	QSPI3_SCLKC			Slave SPI clock inputs
	ASCLIN9_ARXB			Receive input
	P01.7	O0		General-purpose output
	GTM_TOUT115	O1		GTM muxed output
	—	O2		Reserved
	ASCLIN9_ATX	O3		Transmit output
	QSPI3_SCLK	O4		Master SPI clock output
	—	O5		Reserved
	—	O6		Reserved
	—	O7		Reserved

TC37xEXT Pin Definition and Functions LFBGA-292 Package Pinning of

Table 2-22 Port 02 Functions

Ball	Symbol	Ctrl.	Buffer Type	Function
B1	P02.0	I	FAST / PU1 / VEXT / ES	General-purpose input
	GTM_TIM1_IN0_2			Mux input channel 0 of TIM module 1
	GTM_TIM0_IN0_2			Mux input channel 0 of TIM module 0
	CCU61_CC60INB			T12 capture input 60
	ASCLIN2_ARXG			Receive input
	CCU60_CC60INA			T12 capture input 60
	SCU_E_REQ3_2			ERU Channel 3 inputs 0 to 5 (0 is the LSB and 5 is the MSB)
	CIF_D0			sensor pixel data input
	GTM_DTMA0_0			CDTM0_DTM4
	P02.0			O0
	GTM_TOUT0	O1	GTM muxed output	
	IOM_REF0_0	O2	Reference input 0	
	ASCLIN2_ATX		Transmit output	
	IOM_MON2_14		Monitor input 2	
	IOM_REF2_14	O3	Reference input 2	
	QSPI3_SLSO1		Master slave select output	
	EDSADC_CGPWMN	O4	Negative carrier generator output	
	CAN00_TXD	O5	CAN transmit output node 0	
	IOM_MON2_5	O6	Monitor input 2	
	IOM_REF2_5		Reference input 2	
	ERAY0_TXDA	O7	Transmit Channel A	
	CCU60_CC60	O7	T12 PWM channel 60	
	IOM_MON1_2		Monitor input 1	
	IOM_REF1_6		Reference input 1	

TC37xEXT Pin Definition and Functions LFBGA-292 Package Pinning of

Table 2-22 Port 02 Functions (cont'd)

Ball	Symbol	Ctrl.	Buffer Type	Function
C2	P02.1	I	SLOW / PU1 / VEXT / ES	General-purpose input
	GTM_TIM1_IN1_2			Mux input channel 1 of TIM module 1
	GTM_TIM0_IN1_2			Mux input channel 1 of TIM module 0
	ERAY0_RXDA2			Receive Channel A2
	ASCLIN2_ARXB			Receive input
	CAN00_RXDA			CAN receive input node 0
	SCU_E_REQ2_1			ERU Channel 2 inputs 0 to 5 (0 is the LSB and 5 is the MSB)
	CIF_D1			sensor pixel data input
	P02.1			O0
	GTM_TOUT1	O1	GTM muxed output	
	IOM_REF0_1		Reference input 0	
	QSPI4_SLSO7	O2	Master slave select output	
	QSPI3_SLSO2	O3	Master slave select output	
	EDSADC_CGPWMP	O4	Positive carrier generator output	
	—	O5	Reserved	
	—	O6	Reserved	
	CCU60_COUT60	O7	T12 PWM channel 60	
	IOM_MON1_3		Monitor input 1	
	IOM_REF1_3		Reference input 1	

TC37xEXT Pin Definition and Functions LFBGA-292 Package Pinning of

Table 2-22 Port 02 Functions (cont'd)

Ball	Symbol	Ctrl.	Buffer Type	Function
C1	P02.2	I	FAST / PU1 / VEXT / ES	General-purpose input
	GTM_TIM1_IN2_2			Mux input channel 2 of TIM module 1
	GTM_TIM0_IN2_2			Mux input channel 2 of TIM module 0
	CCU61_CC61INB			T12 capture input 61
	CCU60_CC61INA			T12 capture input 61
	CIF_D2			sensor pixel data input
	SENT_SENT14B			Receive input channel 14
	P02.2			O0
	GTM_TOUT2	O1	GTM muxed output	
	IOM_REF0_2	O2	Reference input 0	
	ASCLIN1_ATX		Transmit output	
	IOM_MON2_13		Monitor input 2	
	IOM_REF2_13	Reference input 2		
	QSPI3_SLSO3	O3	Master slave select output	
	PSI5_TX0	O4	TXD outputs (send data)	
	IOM_MON1_14	O5	Monitor input 1	
	IOM_REF1_14		Reference input 1	
	CAN02_TXD		CAN transmit output node 2	
	IOM_MON2_7	Monitor input 2		
	IOM_REF2_7	Reference input 2		
	ERAY0_TXDB	O6	Transmit Channel B	
	CCU60_CC61	O7	T12 PWM channel 61	
	IOM_MON1_1	Monitor input 1		
	IOM_REF1_5	Reference input 1		

TC37xEXT Pin Definition and Functions LFBGA-292 Package Pinning of

Table 2-22 Port 02 Functions (cont'd)

Ball	Symbol	Ctrl.	Buffer Type	Function	
D2	P02.3	I	SLOW / PU1 / VEXT / ES	General-purpose input	
	GTM_TIM1_IN3_2			Mux input channel 3 of TIM module 1	
	GTM_TIM0_IN3_2			Mux input channel 3 of TIM module 0	
	EDSADC_DSCIN5B			Modulator clock input, channel 5	
	ERAY0_RXDB2			Receive Channel B2	
	CAN02_RXDB			CAN receive input node 2	
	ASCLIN1_ARXG			Receive input	
	MSC1_SD11			Upstream asynchronous input signal	
	PSI5_RX0B			RXD inputs (receive data) channel 0	
	CIF_D3			sensor pixel data input	
	SENT_SENT13B			Receive input channel 13	
	P02.3			O0	General-purpose output
	GTM_TOUT3			O1	GTM muxed output
	IOM_REF0_3		Reference input 0		
	ASCLIN2_ASLSO	O2	Slave select signal output		
	QSPI3_SLSO4	O3	Master slave select output		
	EDSADC_DSCOUT5	O4	Modulator clock output		
	—	O5	Reserved		
	—	O6	Reserved		
	CCU60_COUT61	O7	T12 PWM channel 61		
IOM_MON1_4		Monitor input 1			
IOM_REF1_2		Reference input 1			

TC37xEXT Pin Definition and Functions LFBGA-292 Package Pinning of

Table 2-22 Port 02 Functions (cont'd)

Ball	Symbol	Ctrl.	Buffer Type	Function
D1	P02.4	I	FAST / PU1 / VEXT / ES	General-purpose input
	GTM_TIM1_IN4_1			Mux input channel 4 of TIM module 1
	GTM_TIM0_IN4_1			Mux input channel 4 of TIM module 0
	CCU61_CC62INB			T12 capture input 62
	EDSADC_DSDIN5B			Digital datastream input, channel 5
	QSPI3_SLSIA			Slave select input
	CCU60_CC62INA			T12 capture input 62
	I2C0_SDAA			Serial Data Input 0
	CAN11_RXDA			CAN receive input node 1
	CAN0_ECTT1			External CAN time trigger input
	CIF_D4			sensor pixel data input
	SENT_SENT12B			Receive input channel 12
	P02.4			O0
	GTM_TOUT4	O1	GTM muxed output	
	IOM_REF0_4		Reference input 0	
	ASCLIN2_ASCLK	O2	Shift clock output	
	QSPI3_SLSO0	O3	Master slave select output	
	PSI5S_CLK	O4	PSI5S CLK is a clock that can be used on a pin to drive the external PHY.	
	I2C0_SDA	O5	Serial Data Output	
	ERAY0_TXENA	O6	Transmit Enable Channel A	
CCU60_CC62	O7	T12 PWM channel 62		
IOM_MON1_0		Monitor input 1		
IOM_REF1_4		Reference input 1		

TC37xEXT Pin Definition and Functions LFBGA-292 Package Pinning of

Table 2-22 Port 02 Functions (cont'd)

Ball	Symbol	Ctrl.	Buffer Type	Function	
E2	P02.5	I	FAST / PU1 / VEXT / ES	General-purpose input	
	GTM_TIM1_IN5_1			Mux input channel 5 of TIM module 1	
	GTM_TIM0_IN5_1			Mux input channel 5 of TIM module 0	
	EDSADC_DSCIN4B			Modulator clock input, channel 4	
	I2C0_SCLA			Serial Clock Input 0	
	PSI5_RX1B			RXD inputs (receive data) channel 1	
	PSI5S_RXB			RX data input	
	QSPI3_MRSTA			Master SPI data input	
	SENT_SENT3C			Receive input channel 3	
	CAN0_ECTT2			External CAN time trigger input	
	CIF_D5			sensor pixel data input	
	P02.5			O0	General-purpose output
	GTM_TOUT5			O1	GTM muxed output
	IOM_REF0_5		Reference input 0		
	CAN11_TXD	O2	CAN transmit output node 1		
	QSPI3_MRST	O3	Slave SPI data output		
	IOM_MON2_3		Monitor input 2		
	IOM_REF2_3		Reference input 2		
	EDSADC_DSCOUT4	O4	Modulator clock output		
	I2C0_SCL	O5	Serial Clock Output		
ERAY0_TXENB	O6	Transmit Enable Channel B			
CCU60_COUT62	O7	T12 PWM channel 62			
IOM_MON1_5		Monitor input 1			
IOM_REF1_1		Reference input 1			

TC37xEXT Pin Definition and Functions LFBGA-292 Package Pinning of

Table 2-22 Port 02 Functions (cont'd)

Ball	Symbol	Ctrl.	Buffer Type	Function
E1	P02.6	I	FAST / PU1 / VEXT / ES	General-purpose input
	GTM_TIM3_IN0_10			Mux input channel 0 of TIM module 3
	GTM_TIM1_IN6_1			Mux input channel 6 of TIM module 1
	GTM_TIM0_IN6_1			Mux input channel 6 of TIM module 0
	CCU60_CC60INC			T12 capture input 60
	SENT_SENT2C			Receive input channel 2
	EDSADC_DSDIN4B			Digital datastream input, channel 4
	EDSADC_ITR5E			Trigger/Gate input, channel 5
	GPT120_T3INA			Trigger/gate input of core timer T3
	CCU60_CCPOS0A			Hall capture input 0
	CCU61_T12HRB			External timer start 12
	QSPI3_MTSRA			Slave SPI data input
	CIF_D6			sensor pixel data input
	P02.6			O0
	GTM_TOUT6	O1	GTM muxed output	
	IOM_REF0_6		Reference input 0	
	PSI5S_TX	O2	TX data output	
	QSPI3_MTSR	O3	Master SPI data output	
	PSI5_TX1	O4	TXD outputs (send data)	
	IOM_MON1_15		Monitor input 1	
EVADC_EMUX00	O5	Control of external analog multiplexer interface 0		
—	O6	Reserved		
CCU60_CC60	O7	T12 PWM channel 60		
IOM_MON1_2		Monitor input 1		
IOM_REF1_6		Reference input 1		

TC37xEXT Pin Definition and Functions LFBGA-292 Package Pinning of

Table 2-22 Port 02 Functions (cont'd)

Ball	Symbol	Ctrl.	Buffer Type	Function
F2	P02.7	I	FAST / PU1 / VEXT / ES	General-purpose input
	GTM_TIM3_IN1_10			Mux input channel 1 of TIM module 3
	GTM_TIM1_IN7_1			Mux input channel 7 of TIM module 1
	GTM_TIM0_IN7_1			Mux input channel 7 of TIM module 0
	CCU60_CC61INC			T12 capture input 61
	SENT_SENT1C			Receive input channel 1
	EDSADC_DSCIN3B			Modulator clock input, channel 3
	EDSADC_ITR4E			Trigger/Gate input, channel 4
	GPT120_T3EUDA			Count direction control input of core timer T3
	CCU60_CCPOS1A			Hall capture input 1
	CIF_D7			sensor pixel data input
	QSPI3_SCLKA			Slave SPI clock inputs
	CCU61_T13HRB			External timer start 13
	P02.7			O0
	GTM_TOUT7	O1	GTM muxed output	
	IOM_REF0_7		Reference input 0	
	—	O2	Reserved	
	QSPI3_SCLK	O3	Master SPI clock output	
	EDSADC_DSCOUT3	O4	Modulator clock output	
	EVADC_EMUX01	O5	Control of external analog multiplexer interface 0	
SENT_SPC1	O6	Transmit output		
CCU60_CC61	O7	T12 PWM channel 61		
IOM_MON1_1		Monitor input 1		
IOM_REF1_5		Reference input 1		

TC37xEXT Pin Definition and Functions LFBGA-292 Package Pinning of

Table 2-22 Port 02 Functions (cont'd)

Ball	Symbol	Ctrl.	Buffer Type	Function
F1	P02.8	I	SLOW / PU1 / VEXT / ES	General-purpose input
	GTM_TIM3_IN2_10			Mux input channel 2 of TIM module 3
	GTM_TIM3_IN0_2			Mux input channel 0 of TIM module 3
	GTM_TIM2_IN0_2			Mux input channel 0 of TIM module 2
	CCU60_CC62INC			T12 capture input 62
	SENT_SENT0C			Receive input channel 0
	CCU60_CCPOS2A			Hall capture input 2
	EDSADC_DSDIN3B			Digital datastream input, channel 3
	EDSADC_ITR3E			Trigger/Gate input, channel 3
	GPT120_T4INA			Trigger/gate input of timer T4
	CCU61_T12HRC			External timer start 12
	CIF_D8			sensor pixel data input
	CCU61_T13HRC			External timer start 13
	GTM_DTMA0_1			CDTM0_DTM4
	P02.8			O0
	GTM_TOUT8	O1	GTM muxed output	
	IOM_REF0_8		Reference input 0	
	QSPI3_SLSO5	O2	Master slave select output	
	ASCLIN8_ASCLK	O3	Shift clock output	
	—	O4	Reserved	
EVADC_EMUX02	O5	Control of external analog multiplexer interface 0		
GETH_MDC	O6	MDIO clock		
CCU60_CC62	O7	T12 PWM channel 62		
IOM_MON1_0		Monitor input 1		
IOM_REF1_4		Reference input 1		

TC37xEXT Pin Definition and Functions LFBGA-292 Package Pinning of

Table 2-22 Port 02 Functions (cont'd)

Ball	Symbol	Ctrl.	Buffer Type	Function	
E4	P02.9	I	SLOW / PU1 / VEXT / ES	General-purpose input	
	GTM_TIM4_IN2_2			Mux input channel 2 of TIM module 4	
	GTM_TIM3_IN3_10			Mux input channel 3 of TIM module 3	
	GTM_TIM0_IN2_10			Mux input channel 2 of TIM module 0	
	ASCLIN8_ARXA			Receive input	
	P02.9			O0	General-purpose output
	GTM_TOUT116			O1	GTM muxed output
	ASCLIN2_ATX			O2	Transmit output
	IOM_MON2_14				Monitor input 2
	IOM_REF2_14				Reference input 2
	ASCLIN8_ATX	O3	Transmit output		
	—	O4	Reserved		
	CAN01_TXD	O5	CAN transmit output node 1		
	IOM_MON2_6		Monitor input 2		
	IOM_REF2_6		Reference input 2		
—	O6	Reserved			
—	O7	Reserved			
F5	P02.10	I	SLOW / PU1 / VEXT / ES	General-purpose input	
	GTM_TIM4_IN3_2			Mux input channel 3 of TIM module 4	
	GTM_TIM3_IN4_11			Mux input channel 4 of TIM module 3	
	GTM_TIM0_IN3_10			Mux input channel 3 of TIM module 0	
	ASCLIN2_ARXC			Receive input	
	CAN01_RXDE			CAN receive input node 1	
	ASCLIN8_ARXB			Receive input	
	P02.10	O0	General-purpose output		
	GTM_TOUT117	O1	GTM muxed output		
	—	O2	Reserved		
	—	O3	Reserved		
	—	O4	Reserved		
	—	O5	Reserved		
	—	O6	Reserved		
	—	O7	Reserved		

TC37xEXT Pin Definition and Functions LFBGA-292 Package Pinning of

Table 2-22 Port 02 Functions (cont'd)

Ball	Symbol	Ctrl.	Buffer Type	Function
F4	P02.11	I	SLOW / PU1 / VEXT / ES	General-purpose input
	GTM_TIM4_IN4_3			Mux input channel 4 of TIM module 4
	GTM_TIM3_IN5_12			Mux input channel 5 of TIM module 3
	GTM_TIM0_IN7_7			Mux input channel 7 of TIM module 0
	EVADC_G9CH15	AI		Analog input channel 15, group 9
	P02.11	O0		General-purpose output
	GTM_TOUT118	O1		GTM muxed output
	—	O2		Reserved
	ASCLIN8_ASLSO	O3		Slave select signal output
	—	O4		Reserved
	—	O5		Reserved
	—	O6		Reserved
	—	O7		Reserved

Table 2-23 Port 10 Functions

Ball	Symbol	Ctrl.	Buffer Type	Function
A7	P10.0	I	SLOW / PU1 / VEXT / ES	General-purpose input
	GTM_TIM4_IN0_12			Mux input channel 0 of TIM module 4
	GTM_TIM1_IN4_2			Mux input channel 4 of TIM module 1
	GTM_TIM0_IN4_2			Mux input channel 4 of TIM module 0
	GPT120_T6EUDB			Count direction control input of core timer T6
	ASCLIN11_ARXA			Receive input
	GETH_RXERC			Receive Error MII
	P10.0	O0		General-purpose output
	GTM_TOUT102	O1		GTM muxed output
	ASCLIN11_ATX	O2		Transmit output
	QSPI1_SLSO10	O3		Master slave select output
	—	O4		Reserved
	—	O5		Reserved
—	O6	Reserved		
—	O7	Reserved		

TC37xEXT Pin Definition and Functions LFBGA-292 Package Pinning of

Table 2-23 Port 10 Functions (cont'd)

Ball	Symbol	Ctrl.	Buffer Type	Function	
B7	P10.1	I	FAST / PU1 / VEXT / ES	General-purpose input	
	GTM_TIM4_IN4_12			Mux input channel 4 of TIM module 4	
	GTM_TIM1_IN1_3			Mux input channel 1 of TIM module 1	
	GTM_TIM0_IN1_3			Mux input channel 1 of TIM module 0	
	GPT120_T5EUDB			Count direction control input of timer T5	
	QSPI1_MRSTA			Master SPI data input	
	GTM_DTMT0_1			CDTM0_DTM0	
	P10.1			O0	General-purpose output
	GTM_TOUT103			O1	GTM muxed output
	QSPI1_MTSR			O2	Master SPI data output
	QSPI1_MRST			O3	Slave SPI data output
	IOM_MON2_1				Monitor input 2
	IOM_REF2_1				Reference input 2
	MSC0_EN1			O4	Chip Select
	EVADC_FC1BFLOUT			O5	Boundary flag output, FC channel 1
	—			O6	Reserved
	—			O7	Reserved
A5	P10.2	I	FAST / PU1 / VEXT / ES	General-purpose input	
	GTM_TIM4_IN5_12			Mux input channel 5 of TIM module 4	
	GTM_TIM1_IN2_3			Mux input channel 2 of TIM module 1	
	GTM_TIM0_IN2_3			Mux input channel 2 of TIM module 0	
	CAN02_RXDE			CAN receive input node 2	
	MSC0_SD11			Upstream asynchronous input signal	
	QSPI1_SCLKA			Slave SPI clock inputs	
	GPT120_T6INB			Trigger/gate input of core timer T6	
	SCU_E_REQ2_0			ERU Channel 2 inputs 0 to 5 (0 is the LSB and 5 is the MSB)	
	GTM_DTMT2_2			CDTM2_DTM0	
	P10.2			O0	General-purpose output
	GTM_TOUT104			O1	GTM muxed output
	IOM_MON2_9				Monitor input 2
	—			O2	Reserved
	QSPI1_SCLK			O3	Master SPI clock output
	MSC0_EN0			O4	Chip Select
	EVADC_FC3BFLOUT			O5	Boundary flag output, FC channel 3
—	O6	Reserved			
—	O7	Reserved			

TC37xEXT Pin Definition and Functions LFBGA-292 Package Pinning of

Table 2-23 Port 10 Functions (cont'd)

Ball	Symbol	Ctrl.	Buffer Type	Function
A6	P10.3	I	FAST / PU1 / VEXT / ES	General-purpose input
	GTM_TIM4_IN6_10			Mux input channel 6 of TIM module 4
	GTM_TIM1_IN3_3			Mux input channel 3 of TIM module 1
	GTM_TIM0_IN3_3			Mux input channel 3 of TIM module 0
	QSPI1_MTSRA			Slave SPI data input
	SCU_E_REQ3_0			ERU Channel 3 inputs 0 to 5 (0 is the LSB and 5 is the MSB)
	GPT120_T5INB			Trigger/gate input of timer T5
	P10.3			O0
	GTM_TOUT105	O1	GTM muxed output	
	IOM_MON2_10		Monitor input 2	
	—	O2	Reserved	
	QSPI1_MTSR	O3	Master SPI data output	
	MSC0_EN0	O4	Chip Select	
	—	O5	Reserved	
	CAN02_TXD	O6	CAN transmit output node 2	
	IOM_MON2_7		Monitor input 2	
	IOM_REF2_7		Reference input 2	
—	O7	Reserved		
B6	P10.4	I	FAST / PU1 / VEXT / ES	General-purpose input
	GTM_TIM4_IN7_3			Mux input channel 7 of TIM module 4
	GTM_TIM1_IN6_2			Mux input channel 6 of TIM module 1
	GTM_TIM0_IN6_2			Mux input channel 6 of TIM module 0
	QSPI1_MTSRC			Slave SPI data input
	CCU60_CCPOS0C			Hall capture input 0
	GPT120_T3INB			Trigger/gate input of core timer T3
	ASCLIN11_ARXB			Receive input
	P10.4	O0	General-purpose output	
	GTM_TOUT106	O1	GTM muxed output	
	IOM_MON2_11		Monitor input 2	
	—	O2	Reserved	
	QSPI1_SLSO8	O3	Master slave select output	
	QSPI1_MTSR	O4	Master SPI data output	
	MSC0_EN0	O5	Chip Select	
	—	O6	Reserved	
	—	O7	Reserved	

TC37xEXT Pin Definition and Functions LFBGA-292 Package Pinning of

Table 2-23 Port 10 Functions (cont'd)

Ball	Symbol	Ctrl.	Buffer Type	Function
B5	P10.5	I	SLOW / PU2 / VEXT / ES	General-purpose input
	GTM_TIM4_IN3_13			Mux input channel 3 of TIM module 4
	GTM_TIM1_IN2_4			Mux input channel 2 of TIM module 1
	GTM_TIM0_IN2_4			Mux input channel 2 of TIM module 0
	PMS_HWCFCG4IN			HWCFG4 pin input
	CAN20_RXDA			CAN receive input node 0
	MSC0_INJ1			Injection signal from port
	P10.5	O0	General-purpose output	
	GTM_TOUT107	O1	GTM muxed output	
	IOM_REF2_9	O2	Reference input 2	
	ASCLIN2_ATX		Transmit output	
	IOM_MON2_14		Monitor input 2	
	IOM_REF2_14	Reference input 2		
	QSPI3_SLSO8	O3	Master slave select output	
	QSPI1_SLSO9	O4	Master slave select output	
	GPT120_T6OUT	O5	External output for overflow/underflow detection of core timer T6	
	ASCLIN2_ASLSO	O6	Slave select signal output	
—	O7	Reserved		
A4	P10.6	I	SLOW / PU2 / VEXT / ES	General-purpose input
	GTM_TIM4_IN2_13			Mux input channel 2 of TIM module 4
	GTM_TIM1_IN3_4			Mux input channel 3 of TIM module 1
	GTM_TIM0_IN3_4			Mux input channel 3 of TIM module 0
	ASCLIN2_ARXD			Receive input
	QSPI3_MTSRB			Slave SPI data input
	PMS_HWCFCG5IN			HWCFG5 pin input
	P10.6	O0	General-purpose output	
	GTM_TOUT108	O1	GTM muxed output	
	IOM_REF2_10	O2	Reference input 2	
	ASCLIN2_ASCLK		Shift clock output	
	QSPI3_MTSR		Master SPI data output	
	GPT120_T3OUT	O4	External output for overflow/underflow detection of core timer T3	
	CAN20_TXD	O5	CAN transmit output node 0	
	QSPI1_MRST	O6	Slave SPI data output	
	IOM_MON2_1	O7	Monitor input 2	
	IOM_REF2_1		Reference input 2	
—	O7	Reserved		

TC37xEXT Pin Definition and Functions LFBGA-292 Package Pinning of

Table 2-23 Port 10 Functions (cont'd)

Ball	Symbol	Ctrl.	Buffer Type	Function
A3	P10.7	I	SLOW / PU1 / VEXT / ES	General-purpose input
	GTM_TIM1_IN0_3			Mux input channel 0 of TIM module 1
	GTM_TIM0_IN0_3			Mux input channel 0 of TIM module 0
	GPT120_T3EUDB			Count direction control input of core timer T3
	ASCLIN2_ACTSA			Clear to send input
	QSPI3_MRSTB			Master SPI data input
	SCU_E_REQ0_2			ERU Channel 0 inputs 0 to 5 (0 is the LSB and 5 is the MSB)
	CCU60_CCPOS1C			Hall capture input 1
	P10.7			O0
	GTM_TOUT109	O1	GTM muxed output	
	IOM_REF2_11	O2	Reference input 2	
	—		Reserved	
	QSPI3_MRST		O3	Slave SPI data output
	IOM_MON2_3	O3	Monitor input 2	
	IOM_REF2_3		Reference input 2	
	—	O4	Reserved	
	CAN20_TXD	O5	CAN transmit output node 0	
	CAN12_TXD	O6	CAN transmit output node 2	
	—	O7	Reserved	

TC37xEXT Pin Definition and Functions LFBGA-292 Package Pinning of

Table 2-23 Port 10 Functions (cont'd)

Ball	Symbol	Ctrl.	Buffer Type	Function
B4	P10.8	I	SLOW / PU1 / VEXT / ES	General-purpose input
	GTM_TIM4_IN0_13			Mux input channel 0 of TIM module 4
	GTM_TIM1_IN5_2			Mux input channel 5 of TIM module 1
	GTM_TIM0_IN5_2			Mux input channel 5 of TIM module 0
	CAN12_RXDB			CAN receive input node 2
	GPT120_T4INB			Trigger/gate input of timer T4
	QSPI3_SCLKB			Slave SPI clock inputs
	SCU_E_REQ1_2			ERU Channel 1 inputs 0 to 5 (0 is the LSB and 5 is the MSB)
	CCU60_CCPOS2C			Hall capture input 2
	CAN20_RXDB			CAN receive input node 0
	P10.8	O0	General-purpose output	
	GTM_TOUT110	O1	GTM muxed output	
	ASCLIN2_ARTS	O2	Ready to send output	
	QSPI3_SCLK	O3	Master SPI clock output	
	—	O4	Reserved	
	—	O5	Reserved	
	—	O6	Reserved	
—	O7	Reserved		

Table 2-24 Port 11 Functions

Ball	Symbol	Ctrl.	Buffer Type	Function
E10	P11.0	I	RFast / PU1 / VFLEX / ES	General-purpose input
	GTM_TIM4_IN0_4			Mux input channel 0 of TIM module 4
	GTM_TIM2_IN0_7			Mux input channel 0 of TIM module 2
	ASCLIN3_ARXB			Receive input
	GTM_DTMA2_1			CDTM2_DTM4
	P11.0	O0	General-purpose output	
	GTM_TOUT119	O1	GTM muxed output	
	ASCLIN3_ATX	O2	Transmit output	
	IOM_MON2_15		Monitor input 2	
	IOM_REF2_15		Reference input 2	
	—		O3	Reserved
	—	O4	Reserved	
	CAN11_TXD	O5	CAN transmit output node 1	
	GETH_TXD3	O6	Transmit Data	
—	O7	Reserved		

TC37xEXT Pin Definition and Functions LFBGA-292 Package Pinning of

Table 2-24 Port 11 Functions (cont'd)

Ball	Symbol	Ctrl.	Buffer Type	Function
E9	P11.1	I	RFAST / PU1 / VFLEX / ES	General-purpose input
	GTM_TIM4_IN1_5			Mux input channel 1 of TIM module 4
	GTM_TIM2_IN1_6			Mux input channel 1 of TIM module 2
	P11.1	O0		General-purpose output
	GTM_TOUT120	O1		GTM muxed output
	ASCLIN3_ASCLK	O2		Shift clock output
	ASCLIN3_ATX	O3		Transmit output
	IOM_MON2_15			Monitor input 2
	IOM_REF2_15			Reference input 2
	—	O4		Reserved
	CAN12_TXD	O5		CAN transmit output node 2
	GETH_TXD2	O6		Transmit Data
	—	O7		Reserved
A10	P11.2	I	RFAST / PU1 / VFLEX / ES	General-purpose input
	GTM_TIM3_IN1_3			Mux input channel 1 of TIM module 3
	GTM_TIM2_IN1_3			Mux input channel 1 of TIM module 2
	P11.2	O0		General-purpose output
	GTM_TOUT95	O1		GTM muxed output
	—	O2		Reserved
	QSPIO_SLSO5	O3		Master slave select output
	QSPI1_SLSO5	O4		Master slave select output
	MSC0_EN1	O5		Chip Select
	GETH_TXD1	O6		Transmit Data
	CCU60_COUT63	O7		T13 PWM channel 63
	IOM_MON1_6			Monitor input 1
	IOM_REF1_0			Reference input 1

TC37xEXT Pin Definition and Functions LFBGA-292 Package Pinning of

Table 2-24 Port 11 Functions (cont'd)

Ball	Symbol	Ctrl.	Buffer Type	Function
B10	P11.3	I	RFAST / PU1 / VFLEX / ES	General-purpose input
	GTM_TIM3_IN2_2			Mux input channel 2 of TIM module 3
	GTM_TIM2_IN2_2			Mux input channel 2 of TIM module 2
	MSC0_SDI3			Upstream asynchronous input signal
	QSPI1_MRSTB			Master SPI data input
	P11.3	O0	General-purpose output	
	GTM_TOUT96	O1	GTM muxed output	
	—	O2	Reserved	
	QSPI1_MRST	O3	Slave SPI data output	
	IOM_MON2_1		Monitor input 2	
	IOM_REF2_1		Reference input 2	
	ERAY0_TXDA	O4	Transmit Channel A	
	—	O5	Reserved	
	GETH_TXD0	O6	Transmit Data	
	CCU60_COUT62	O7	T12 PWM channel 62	
	IOM_MON1_5		Monitor input 1	
IOM_REF1_1	Reference input 1			
D10	P11.4	I	RFAST / PU1 / VFLEX / ES	General-purpose input
	GTM_TIM4_IN2_5			Mux input channel 2 of TIM module 4
	GTM_TIM2_IN2_6			Mux input channel 2 of TIM module 2
	GETH_RXCLKB			Receive Clock MII
	P11.4	O0	General-purpose output	
	GTM_TOUT121	O1	GTM muxed output	
	ASCLIN3_ASCLK	O2	Shift clock output	
	—	O3	Reserved	
	—	O4	Reserved	
	CAN13_TXD	O5	CAN transmit output node 3	
	GETH_TXER	O6	Transmit Error MII	
GETH_TXCLK	O7	Transmit Clock Output for RGMII		

TC37xEXT Pin Definition and Functions LFBGA-292 Package Pinning of

Table 2-24 Port 11 Functions (cont'd)

Ball	Symbol	Ctrl.	Buffer Type	Function
D8	P11.5	I	SLOW / RGMII_Input / PU1 / VFLEX / ES	General-purpose input
	GTM_TIM4_IN3_5			Mux input channel 3 of TIM module 4
	GTM_TIM2_IN3_8			Mux input channel 3 of TIM module 2
	GETH_TXCLKA			Transmit Clock Input for MII
	GETH_GREFCLK			Gigabit Reference Clock input for RGMII (125 MHz high precision)
	P11.5	O0	General-purpose output	
	GTM_TOUT122	O1	GTM muxed output	
	—	O2	Reserved	
	—	O3	Reserved	
	—	O4	Reserved	
	CAN20_TXD	O5	CAN transmit output node 0	
	—	O6	Reserved	
	—	O7	Reserved	
D9	P11.6	I	RFast / PU1 / VFLEX / ES	General-purpose input
	GTM_TIM3_IN3_2			Mux input channel 3 of TIM module 3
	GTM_TIM2_IN3_2			Mux input channel 3 of TIM module 2
	QSPI1_SCLKB			Slave SPI clock inputs
	P11.6	O0	General-purpose output	
	GTM_TOUT97	O1	GTM muxed output	
	ERAY0_TXENB	O2	Transmit Enable Channel B	
	QSPI1_SCLK	O3	Master SPI clock output	
	ERAY0_TXENA	O4	Transmit Enable Channel A	
	MSC0_FCLP	O5	Shift-clock direct part of the differential signal	
	GETH_TXEN	O6	Transmit Enable MII and RMII	
	GETH_TCTL		Transmit Control for RGMII	
	CCU60_COUT61	O7	T12 PWM channel 61	
	IOM_MON1_4		Monitor input 1	
	IOM_REF1_2		Reference input 1	

TC37xEXT Pin Definition and Functions LFBGA-292 Package Pinning of

Table 2-24 Port 11 Functions (cont'd)

Ball	Symbol	Ctrl.	Buffer Type	Function
E8	P11.7	I	SLOW / RGMII_Input / PU1 / VFLEX / ES	General-purpose input
	GTM_TIM4_IN4_5			Mux input channel 4 of TIM module 4
	GTM_TIM2_IN4_7			Mux input channel 4 of TIM module 2
	GETH_RXD3A			Receive Data 3 MII and RGMII (RGMII can use RXD3A only)
	CAN11_RXDD			CAN receive input node 1
	P11.7	O0	General-purpose output	
	GTM_TOUT123	O1	GTM muxed output	
	—	O2	Reserved	
	—	O3	Reserved	
	—	O4	Reserved	
	—	O5	Reserved	
	—	O6	Reserved	
	—	O7	Reserved	
E7	P11.8	I	SLOW / RGMII_Input / PU1 / VFLEX / ES	General-purpose input
	GTM_TIM4_IN5_5			Mux input channel 5 of TIM module 4
	GTM_TIM2_IN5_8			Mux input channel 5 of TIM module 2
	GETH_RXD2A			Receive Data 2 MII and RGMII (RGMII can use RXD2A only)
	CAN12_RXDD			CAN receive input node 2
	P11.8	O0	General-purpose output	
	GTM_TOUT124	O1	GTM muxed output	
	—	O2	Reserved	
	—	O3	Reserved	
	—	O4	Reserved	
	—	O5	Reserved	
	—	O6	Reserved	
	—	O7	Reserved	

TC37xEXT Pin Definition and Functions LFBGA-292 Package Pinning of

Table 2-24 Port 11 Functions (cont'd)

Ball	Symbol	Ctrl.	Buffer Type	Function
A9	P11.9	I	FAST / RGMII_Input / PU1 / VFLEX / ES	General-purpose input
	GTM_TIM3_IN4_2			Mux input channel 4 of TIM module 3
	GTM_TIM2_IN4_2			Mux input channel 4 of TIM module 2
	QSPI1_MTSRB			Slave SPI data input
	ERAY0_RXDA1			Receive Channel A1
	GETH_RXD1A			Receive Data 1 MII, RMI and RGMII (RGMII can use RXD1A only)
	P11.9	O0	General-purpose output	
	GTM_TOUT98	O1	GTM muxed output	
	—	O2	Reserved	
	QSPI1_MTSR	O3	Master SPI data output	
	—	O4	Reserved	
	MSC0_SOP	O5	Data output - direct part of the differential signal	
	—	O6	Reserved	
	CCU60_COUT60	O7	T12 PWM channel 60	
	IOM_MON1_3		Monitor input 1	
	IOM_REF1_3		Reference input 1	

TC37xEXT Pin Definition and Functions LFBGA-292 Package Pinning of

Table 2-24 Port 11 Functions (cont'd)

Ball	Symbol	Ctrl.	Buffer Type	Function	
B9	P11.10	I	FAST / RGMII_Input / PU1 / VFLEX / ES	General-purpose input	
	GTM_TIM3_IN5_2			Mux input channel 5 of TIM module 3	
	GTM_TIM2_IN5_2			Mux input channel 5 of TIM module 2	
	GTM_TIM2_IN0_9			Mux input channel 0 of TIM module 2	
	CAN03_RXDD			CAN receive input node 3	
	ERAY0_RXDB1			Receive Channel B1	
	ASCLIN1_ARXE			Receive input	
	SCU_E_REQ6_3			ERU Channel 6 inputs 0 to 5 (0 is the LSB and 5 is the MSB)	
	MSC0_SDI0			Upstream asynchronous input signal	
	GETH_RXD0A			Receive Data 0 MII, RMI and RGMII (RGMII can use RXD0A only)	
	QSPI1_SLSIA			Slave select input	
	P11.10			O0	General-purpose output
	GTM_TOUT99			O1	GTM muxed output
	—			O2	Reserved
QSPI0_SLSO3	O3	Master slave select output			
QSPI1_SLSO3	O4	Master slave select output			
—	O5	Reserved			
—	O6	Reserved			
CCU60_CC62	O7	T12 PWM channel 62			
IOM_MON1_0		Monitor input 1			
IOM_REF1_4		Reference input 1			

TC37xEXT Pin Definition and Functions LFBGA-292 Package Pinning of

Table 2-24 Port 11 Functions (cont'd)

Ball	Symbol	Ctrl.	Buffer Type	Function
A8	P11.11	I	FAST / RGMII_In put / PU1 / VFLEX / ES	General-purpose input
	GTM_TIM3_IN6_2			Mux input channel 6 of TIM module 3
	GTM_TIM3_IN0_14			Mux input channel 0 of TIM module 3
	GTM_TIM2_IN6_2			Mux input channel 6 of TIM module 2
	GETH_CRSDVA			Carrier Sense / Data Valid combi-signal for RMII
	GETH_RXDVA			Receive Data Valid MII
	GETH_CRSB			Carrier Sense MII
	GETH_RCTLA			Receive Control for RGMII
	P11.11			O0
	GTM_TOUT100	O1	GTM muxed output	
	—	O2	Reserved	
	QSPIO_SLSO4	O3	Master slave select output	
	QSPI1_SLSO4	O4	Master slave select output	
	MSC0_EN0	O5	Chip Select	
	ERAY0_TXENB	O6	Transmit Enable Channel B	
	CCU60_CC61	O7	T12 PWM channel 61	
	IOM_MON1_1		Monitor input 1	
	IOM_REF1_5		Reference input 1	
B8	P11.12	I	FAST / RGMII_In put / PU1 / VFLEX / ES	General-purpose input
	GTM_TIM3_IN7_2			Mux input channel 7 of TIM module 3
	GTM_TIM2_IN7_2			Mux input channel 7 of TIM module 2
	GETH_REFCLKA			Reference Clock input for RMII (50 MHz)
	GETH_TXCLKB			Transmit Clock Input for MII
	GETH_RXCLKA			Receive Clock MII
	P11.12	O0	General-purpose output	
	GTM_TOUT101	O1	GTM muxed output	
	ASCLIN1_ATX	O2	Transmit output	
	IOM_MON2_13		Monitor input 2	
	IOM_REF2_13		Reference input 2	
	GTM_CLK2	O3	CGM generated clock	
	ERAY0_TXDB	O4	Transmit Channel B	
	CAN03_TXD	O5	CAN transmit output node 3	
	IOM_MON2_8		Monitor input 2	
	IOM_REF2_8		Reference input 2	
	CCU_EXTCLK1	O6	External Clock 1	
	CCU60_CC60	O7	T12 PWM channel 60	
IOM_MON1_2		Monitor input 1		
IOM_REF1_6		Reference input 1		

TC37xEXT Pin Definition and Functions LFBGA-292 Package Pinning of

Table 2-24 Port 11 Functions (cont'd)

Ball	Symbol	Ctrl.	Buffer Type	Function
E6	P11.13	I	SLOW / PU1 / VFLEX / ES	General-purpose input
	GTM_TIM4_IN6_5			Mux input channel 6 of TIM module 4
	GTM_TIM2_IN6_7			Mux input channel 6 of TIM module 2
	GETH_RXERA			Receive Error MII
	CAN13_RXDD			CAN receive input node 3
	P11.13			O0
	GTM_TOUT125	O1	GTM muxed output	
	—	O2	Reserved	
	—	O3	Reserved	
	—	O4	Reserved	
	—	O5	Reserved	
	—	O6	Reserved	
	—	O7	Reserved	
D7	P11.14	I	SLOW / PU1 / VFLEX / ES	General-purpose input
	GTM_TIM4_IN7_4			Mux input channel 7 of TIM module 4
	GTM_TIM2_IN7_8			Mux input channel 7 of TIM module 2
	GETH_CRSDVB			Carrier Sense / Data Valid combi-signal for RMII
	GETH_RXDVB			Receive Data Valid MII
	GETH_CRSA			Carrier Sense MII
	CAN20_RXDF	CAN receive input node 0		
	P11.14	O0	General-purpose output	
	GTM_TOUT126	O1	GTM muxed output	
	—	O2	Reserved	
	—	O3	Reserved	
	—	O4	Reserved	
	—	O5	Reserved	
—	O6	Reserved		
—	O7	Reserved		

TC37xEXT Pin Definition and Functions LFBGA-292 Package Pinning of

Table 2-24 Port 11 Functions (cont'd)

Ball	Symbol	Ctrl.	Buffer Type	Function
D6	P11.15	I	SLOW / PU1 / VFLEX / ES	General-purpose input
	GTM_TIM4_IN7_5			Mux input channel 7 of TIM module 4
	GTM_TIM0_IN7_8			Mux input channel 7 of TIM module 0
	GETH_COLA			Collision MII
	P11.15	O0		General-purpose output
	GTM_TOUT127	O1		GTM muxed output
	—	O2		Reserved
	—	O3		Reserved
	—	O4		Reserved
	—	O5		Reserved
	—	O6		Reserved
	—	O7		Reserved

Table 2-25 Port 12 Functions

Ball	Symbol	Ctrl.	Buffer Type	Function
E12	P12.0	I	SLOW / PU1 / VFLEX / ES	General-purpose input
	GTM_TIM4_IN0_5			Mux input channel 0 of TIM module 4
	GTM_TIM3_IN0_7			Mux input channel 0 of TIM module 3
	CAN00_RXDC			CAN receive input node 0
	GETH_RXCLKC			Receive Clock MII
	GTM_DTMA4_0			CDTM4_DTM4
	P12.0	O0		General-purpose output
	GTM_TOUT128	O1		GTM muxed output
	—	O2		Reserved
	—	O3		Reserved
	—	O4		Reserved
	—	O5		Reserved
	GETH_MDC	O6		MDIO clock
—	O7	Reserved		

TC37xEXT Pin Definition and Functions LFBGA-292 Package Pinning of

Table 2-25 Port 12 Functions (cont'd)

Ball	Symbol	Ctrl.	Buffer Type	Function
E11	P12.1	I	SLOW / PU1 / VFLEX / ES	General-purpose input
	GTM_TIM4_IN1_6			Mux input channel 1 of TIM module 4
	GTM_TIM3_IN1_6			Mux input channel 1 of TIM module 3
	GETH_MDIOC			MDIO Input
	P12.1	O0	General-purpose output	
	GTM_TOUT129	O1	GTM muxed output	
	ASCLIN3_ASLSO	O2	Slave select signal output	
	—	O3	Reserved	
	—	O4	Reserved	
	CAN00_TXD	O5	CAN transmit output node 0	
	IOM_MON2_5		Monitor input 2	
	IOM_REF2_5		Reference input 2	
	—	O6	Reserved	
	—	O7	Reserved	
	GETH_MDIO	O	MDIO Output	

Table 2-26 Port 13 Functions

Ball	Symbol	Ctrl.	Buffer Type	Function
B12	P13.0	I	LVDS_TX / FAST / PU1 / VEXT / ES6	General-purpose input
	GTM_TIM3_IN5_3			Mux input channel 5 of TIM module 3
	GTM_TIM2_IN5_3			Mux input channel 5 of TIM module 2
	ASCLIN10_ARXC			Receive input
	P13.0	O0	General-purpose output	
	GTM_TOUT91	O1	GTM muxed output	
	ASCLIN10_ATX	O2	Transmit output	
	QSPI2_SCLKN	O3	Master SPI clock output (LVDS N line)	
	MSC0_EN1	O4	Chip Select	
	MSC0_FCLN	O5	Shift-clock inverted part of the differential signal	
	—	O6	Reserved	
	CAN10_TXD	O7	CAN transmit output node 0	

TC37xEXT Pin Definition and Functions LFBGA-292 Package Pinning of

Table 2-26 Port 13 Functions (cont'd)

Ball	Symbol	Ctrl.	Buffer Type	Function
A12	P13.1	I	LVDS_TX / FAST / PU1 / VEXT / ES6	General-purpose input
	GTM_TIM3_IN6_3			Mux input channel 6 of TIM module 3
	GTM_TIM2_IN6_3			Mux input channel 6 of TIM module 2
	I2C0_SCLB			Serial Clock Input 1
	CAN10_RXDD			CAN receive input node 0
	ASCLIN10_ARXD			Receive input
	P13.1			O0
	GTM_TOUT92	O1	GTM muxed output	
	—	O2	Reserved	
	QSPI2_SCLKP	O3	Master SPI clock output (LVDS P line)	
	—	O4	Reserved	
	MSC0_FCLP	O5	Shift-clock direct part of the differential signal	
	I2C0_SCL	O6	Serial Clock Output	
	—	O7	Reserved	
B11	P13.2	I	LVDS_TX / FAST / PU1 / VEXT / ES6	General-purpose input
	GTM_TIM3_IN7_3			Mux input channel 7 of TIM module 3
	GTM_TIM2_IN7_3			Mux input channel 7 of TIM module 2
	GPT120_CAPINA			Trigger input to capture value of timer T5 into CAPREL register
	I2C0_SDAB		Serial Data Input 1	
	P13.2	O0	General-purpose output	
	GTM_TOUT93	O1	GTM muxed output	
	ASCLIN10_ASCLK	O2	Shift clock output	
	QSPI2_MTSRN	O3	Master SPI data output (LVDS N line)	
	MSC0_FCLP	O4	Shift-clock direct part of the differential signal	
	MSC0_SON	O5	Data output - inverted part of the differential signal	
	I2C0_SDA	O6	Serial Data Output	
	—	O7	Reserved	

TC37xEXT Pin Definition and Functions LFBGA-292 Package Pinning of

Table 2-26 Port 13 Functions (cont'd)

Ball	Symbol	Ctrl.	Buffer Type	Function
A11	P13.3	I	LVDS_TX / FAST / PU1 / VEXT / ES6	General-purpose input
	GTM_TIM3_IN0_3			Mux input channel 0 of TIM module 3
	GTM_TIM2_IN0_3			Mux input channel 0 of TIM module 2
	P13.3	O0		General-purpose output
	GTM_TOUT94	O1		GTM muxed output
	ASCLIN10_ASLSO	O2		Slave select signal output
	QSPI2_MTSRP	O3		Master SPI data output (LVDS P line)
	—	O4		Reserved
	MSC0_SOP	O5		Data output - direct part of the differential signal
	—	O6		Reserved
	—	O7		Reserved

Table 2-27 Port 14 Functions

Ball	Symbol	Ctrl.	Buffer Type	Function
B16	P14.0	I	FAST / PU1 / VEXT / ES2	General-purpose input
	GTM_TIM1_IN3_5			Mux input channel 3 of TIM module 1
	GTM_TIM0_IN3_5			Mux input channel 3 of TIM module 0
	P14.0	O0		General-purpose output
	GTM_TOUT80	O1		GTM muxed output
	ASCLIN0_ATX	O2		Transmit output
	IOM_MON2_12			Monitor input 2
	IOM_REF2_12			Reference input 2
	ERAY0_TXDA	O3		Transmit Channel A
	ERAY0_TXDB	O4		Transmit Channel B
	CAN01_TXD	O5		CAN transmit output node 1
	IOM_MON2_6			Monitor input 2
	IOM_REF2_6			Reference input 2
	ASCLIN0_ASCLK	O6		Shift clock output
	CCU60_COUT62	O7		T12 PWM channel 62
	IOM_MON1_5			Monitor input 1
	IOM_REF1_1			Reference input 1

TC37xEXT Pin Definition and Functions LFBGA-292 Package Pinning of

Table 2-27 Port 14 Functions (cont'd)

Ball	Symbol	Ctrl.	Buffer Type	Function
A15	P14.1	I	FAST / PU1 / VEXT / ES2	General-purpose input
	GTM_TIM1_IN4_3			Mux input channel 4 of TIM module 1
	GTM_TIM0_IN4_3			Mux input channel 4 of TIM module 0
	ERAY0_RXDA3			Receive Channel A3
	ASCLIN0_ARXA			Receive input
	ERAY0_RXDB3			Receive Channel B3
	CAN01_RXDB			CAN receive input node 1
	SCU_E_REQ3_1			ERU Channel 3 inputs 0 to 5 (0 is the LSB and 5 is the MSB)
	PMS_PINAWKP			PINA (P14.1) pin input
	P14.1			O0
	GTM_TOUT81	O1	GTM muxed output	
	ASCLIN0_ATX	O2	Transmit output	
	IOM_MON2_12		Monitor input 2	
	IOM_REF2_12		Reference input 2	
	—	O3	Reserved	
	—	O4	Reserved	
	—	O5	Reserved	
	—	O6	Reserved	
	CCU60_COUT63	O7	T13 PWM channel 63	
	IOM_MON1_6		Monitor input 1	
IOM_REF1_0	Reference input 1			
E13	P14.2	I	SLOW / PU2 / VEXT / ES	General-purpose input
	GTM_TIM1_IN5_3			Mux input channel 5 of TIM module 1
	GTM_TIM0_IN5_3			Mux input channel 5 of TIM module 0
	PMS_HWCFG2IN			HWCFG2 pin input
	P14.2	O0	General-purpose output	
	GTM_TOUT82	O1	GTM muxed output	
	ASCLIN2_ATX	O2	Transmit output	
	IOM_MON2_14		Monitor input 2	
	IOM_REF2_14		Reference input 2	
	QSPI2_SLSO1	O3	Master slave select output	
	—	O4	Reserved	
	—	O5	Reserved	
	ASCLIN2_ASCLK	O6	Shift clock output	
	—	O7	Reserved	

TC37xEXT Pin Definition and Functions LFBGA-292 Package Pinning of

Table 2-27 Port 14 Functions (cont'd)

Ball	Symbol	Ctrl.	Buffer Type	Function
B14	P14.3	I	SLOW / PU2 / VEXT / ES	General-purpose input
	GTM_TIM1_IN6_3			Mux input channel 6 of TIM module 1
	GTM_TIM0_IN6_3			Mux input channel 6 of TIM module 0
	PMS_HWCFG3IN			HWCFG3 pin input
	ASCLIN2_ARXA			Receive input
	MSC0_SDI2			Upstream assynchronous input signal
	SCU_E_REQ1_0			ERU Channel 1 inputs 0 to 5 (0 is the LSB and 5 is the MSB)
	P14.3	O0	General-purpose output	
	GTM_TOUT83	O1	GTM muxed output	
	ASCLIN2_ATX	O2	Transmit output	
	IOM_MON2_14		Monitor input 2	
	IOM_REF2_14		Reference input 2	
	QSPI2_SLSO3	O3	Master slave select output	
	ASCLIN1_ASLSO	O4	Slave select signal output	
	ASCLIN3_ASLSO	O5	Slave select signal output	
	—	O6	Reserved	
—	O7	Reserved		
B15	P14.4	I	SLOW / PU2 / VEXT / ES	General-purpose input
	GTM_TIM1_IN7_2			Mux input channel 7 of TIM module 1
	GTM_TIM0_IN7_2			Mux input channel 7 of TIM module 0
	PMS_HWCFG6IN			HWCFG6 pin input
	GTM_DTMT0_0			CDTM0_DTM0
	P14.4	O0	General-purpose output	
	GTM_TOUT84	O1	GTM muxed output	
	—	O2	Reserved	
	—	O3	Reserved	
	—	O4	Reserved	
	—	O5	Reserved	
	GETH_PPS	O6	Pulse Per Second	
	—	O7	Reserved	

TC37xEXT Pin Definition and Functions LFBGA-292 Package Pinning of

Table 2-27 Port 14 Functions (cont'd)

Ball	Symbol	Ctrl.	Buffer Type	Function
A14	P14.5	I	FAST / PU2 / VEXT / ES	General-purpose input
	GTM_TIM1_IN0_4			Mux input channel 0 of TIM module 1
	GTM_TIM0_IN0_4			Mux input channel 0 of TIM module 0
	PMS_HWCFG1IN			HWCFG1 pin input
	GTM_DTMA2_0			CDTM2_DTM4
	P14.5			O0
	GTM_TOUT85	O1	GTM muxed output	
	—	O2	Reserved	
	—	O3	Reserved	
	—	O4	Reserved	
	—	O5	Reserved	
	ERAY0_TXDB	O6	Transmit Channel B	
	—	O7	Reserved	
B13	P14.6	I	FAST / PU1 / VEXT / ES	General-purpose input
	GTM_TIM1_IN1_4			Mux input channel 1 of TIM module 1
	GTM_TIM0_IN1_4			Mux input channel 1 of TIM module 0
	P14.6	O0	General-purpose output	
	GTM_TOUT86	O1	GTM muxed output	
	—	O2	Reserved	
	QSPI2_SLSO2	O3	Master slave select output	
	CAN13_TXD	O4	CAN transmit output node 3	
	—	O5	Reserved	
	ERAY0_TXENB	O6	Transmit Enable Channel B	
	—	O7	Reserved	

TC37xEXT Pin Definition and Functions LFBGA-292 Package Pinning of

Table 2-27 Port 14 Functions (cont'd)

Ball	Symbol	Ctrl.	Buffer Type	Function
D13	P14.7	I	SLOW / PU1 / VEXT / ES	General-purpose input
	GTM_TIM4_IN7_10			Mux input channel 7 of TIM module 4
	GTM_TIM1_IN0_5			Mux input channel 0 of TIM module 1
	GTM_TIM0_IN0_5			Mux input channel 0 of TIM module 0
	ERAY0_RXDB0			Receive Channel B0
	CAN10_RXDB			CAN receive input node 0
	CAN13_RXDA			CAN receive input node 3
	ASCLIN9_ARXC			Receive input
	P14.7	O0	General-purpose output	
	GTM_TOUT87	O1	GTM muxed output	
	ASCLIN0_ARTS	O2	Ready to send output	
	QSPI2_SLSO4	O3	Master slave select output	
	ASCLIN9_ATX	O4	Transmit output	
	—	O5	Reserved	
—	O6	Reserved		
—	O7	Reserved		
A13	P14.8	I	SLOW / PU1 / VEXT / ES	General-purpose input
	GTM_TIM3_IN2_3			Mux input channel 2 of TIM module 3
	GTM_TIM2_IN2_3			Mux input channel 2 of TIM module 2
	ERAY0_RXDA0			Receive Channel A0
	CAN02_RXDD			CAN receive input node 2
	ASCLIN1_ARXD			Receive input
	P14.8	O0	General-purpose output	
	GTM_TOUT88	O1	GTM muxed output	
	ASCLIN5_ASLSO	O2	Slave select signal output	
	ASCLIN7_ASLSO	O3	Slave select signal output	
	—	O4	Reserved	
	—	O5	Reserved	
	—	O6	Reserved	
	—	O7	Reserved	

TC37xEXT Pin Definition and Functions LFBGA-292 Package Pinning of

Table 2-27 Port 14 Functions (cont'd)

Ball	Symbol	Ctrl.	Buffer Type	Function
D12	P14.9	I	LVDS_R X/FAST/ PU1/ VEXT/ ES	General-purpose input
	GTM_TIM3_IN3_3			Mux input channel 3 of TIM module 3
	GTM_TIM2_IN3_3			Mux input channel 3 of TIM module 2
	ASCLIN0_ACTSA			Clear to send input
	QSPI2_MRSTFN			Master SPI data input (LVDS N line)
	ASCLIN9_ARXD			Receive input
	P14.9	O0	General-purpose output	
	GTM_TOUT89	O1	GTM muxed output	
	CAN23_TXD	O2	CAN transmit output node 3	
	MSC0_EN1	O3	Chip Select	
	CAN10_TXD	O4	CAN transmit output node 0	
	ERAY0_TXENB	O5	Transmit Enable Channel B	
	ERAY0_TXENA	O6	Transmit Enable Channel A	
	—	O7	Reserved	
D11	P14.10	I	LVDS_R X/FAST/ PU1/ VEXT/ ES	General-purpose input
	GTM_TIM3_IN4_3			Mux input channel 4 of TIM module 3
	GTM_TIM2_IN4_3			Mux input channel 4 of TIM module 2
	CAN23_RXDA			CAN receive input node 3
	QSPI2_MRSTFP			Master SPI data input (LVDS P line)
	P14.10	O0	General-purpose output	
	GTM_TOUT90	O1	GTM muxed output	
	—	O2	Reserved	
	MSC0_EN0	O3	Chip Select	
	ASCLIN1_ATX	O4	Transmit output	
	IOM_MON2_13		Monitor input 2	
	IOM_REF2_13		Reference input 2	
	CAN02_TXD	O5	CAN transmit output node 2	
	IOM_MON2_7	O6	Monitor input 2	
	IOM_REF2_7		Reference input 2	
	ERAY0_TXDA	O6	Transmit Channel A	
—	O7	Reserved		

TC37xEXT Pin Definition and Functions LFBGA-292 Package Pinning of

Table 2-28 Port 15 Functions

Ball	Symbol	Ctrl.	Buffer Type	Function	
B20	P15.0	I	FAST / PU1 / VEXT / ES	General-purpose input	
	GTM_TIM3_IN3_4			Mux input channel 3 of TIM module 3	
	GTM_TIM2_IN3_4			Mux input channel 3 of TIM module 2	
	SDMMC0_DAT7_IN			read data in	
	P15.0			O0	General-purpose output
	GTM_TOUT71			O1	GTM muxed output
	ASCLIN1_ATX			O2	Transmit output
	IOM_MON2_13				Monitor input 2
	IOM_REF2_13				Reference input 2
	QSPI0_SLSO13				O3
	—			O4	Reserved
	CAN02_TXD			O5	CAN transmit output node 2
	IOM_MON2_7			O6	Monitor input 2
	IOM_REF2_7				Reference input 2
	ASCLIN1_ASCLK				Shift clock output
	—			O7	Reserved
SDMMC0_DAT7	O	write data out			
A18	P15.1	I	FAST / PU1 / VEXT / ES	General-purpose input	
	GTM_TIM3_IN4_4			Mux input channel 4 of TIM module 3	
	GTM_TIM2_IN4_4			Mux input channel 4 of TIM module 2	
	CAN02_RXDA			CAN receive input node 2	
	ASCLIN1_ARXA			Receive input	
	QSPI2_SLSIB			Slave select input	
	SCU_E_REQ7_2			ERU Channel 7 inputs 0 to 5 (0 is the LSB and 5 is the MSB)	
	P15.1			O0	General-purpose output
	GTM_TOUT72			O1	GTM muxed output
	ASCLIN1_ATX			O2	Transmit output
	IOM_MON2_13				Monitor input 2
	IOM_REF2_13				Reference input 2
	QSPI2_SLSO5				O3
	—			O4	Reserved
	—			O5	Reserved
	—			O6	Reserved
SDMMC0_CLK	O7	card clock			

TC37xEXT Pin Definition and Functions LFBGA-292 Package Pinning of

Table 2-28 Port 15 Functions (cont'd)

Ball	Symbol	Ctrl.	Buffer Type	Function
C19	P15.2	I	FAST / PU1 / VEXT / ES	General-purpose input
	GTM_TIM3_IN5_4			Mux input channel 5 of TIM module 3
	GTM_TIM2_IN5_4			Mux input channel 5 of TIM module 2
	QSPI2_SLSIA			Slave select input
	SENT_SENT10D			Receive input channel 10
	QSPI2_MRSTE			Master SPI data input
	P15.2	O0		General-purpose output
	GTM_TOUT73	O1		GTM muxed output
	ASCLIN0_ATX	O2		Transmit output
	IOM_MON2_12			Monitor input 2
	IOM_REF2_12			Reference input 2
	QSPI2_SLSO0	O3		Master slave select output
	—	O4		Reserved
	CAN01_TXD	O5		CAN transmit output node 1
	IOM_MON2_6	O6		Monitor input 2
	IOM_REF2_6			Reference input 2
	ASCLIN0_ASCLK			Shift clock output
	—	O7		Reserved
	B17	P15.3		I
GTM_TIM3_IN6_4		Mux input channel 6 of TIM module 3		
GTM_TIM2_IN6_4		Mux input channel 6 of TIM module 2		
CAN01_RXDA		CAN receive input node 1		
ASCLIN0_ARXB		Receive input		
QSPI2_SCLKA		Slave SPI clock inputs		
SDMMC0_CMD_IN		command in		
P15.3		O0	General-purpose output	
GTM_TOUT74		O1	GTM muxed output	
ASCLIN0_ATX		O2	Transmit output	
IOM_MON2_12			Monitor input 2	
IOM_REF2_12			Reference input 2	
QSPI2_SCLK		O3	Master SPI clock output	
—		O4	Reserved	
MSC0_EN1		O5	Chip Select	
—		O6	Reserved	
—		O7	Reserved	
SDMMC0_CMD		O	command out	

TC37xEXT Pin Definition and Functions LFBGA-292 Package Pinning of

Table 2-28 Port 15 Functions (cont'd)

Ball	Symbol	Ctrl.	Buffer Type	Function
A17	P15.4	I	FAST / PU1 / VEXT / ES	General-purpose input
	GTM_TIM3_IN7_4			Mux input channel 7 of TIM module 3
	GTM_TIM2_IN7_4			Mux input channel 7 of TIM module 2
	I2C0_SCLC			Serial Clock Input 2
	QSPI2_MRSTA			Master SPI data input
	SCU_E_REQ0_0			ERU Channel 0 inputs 0 to 5 (0 is the LSB and 5 is the MSB)
	SENT_SENT11D			Receive input channel 11
	P15.4			O0
	GTM_TOUT75	O1	GTM muxed output	
	ASCLIN1_ATX	O2	Transmit output	
	IOM_MON2_13		Monitor input 2	
	IOM_REF2_13		Reference input 2	
	QSPI2_MRST	O3	Slave SPI data output	
	IOM_MON2_2		Monitor input 2	
	IOM_REF2_2		Reference input 2	
	—	O4	Reserved	
	—	O5	Reserved	
	I2C0_SCL	O6	Serial Clock Output	
	CCU60_CC62	O7	T12 PWM channel 62	
	IOM_MON1_0		Monitor input 1	
IOM_REF1_4	Reference input 1			

TC37xEXT Pin Definition and Functions LFBGA-292 Package Pinning of

Table 2-28 Port 15 Functions (cont'd)

Ball	Symbol	Ctrl.	Buffer Type	Function	
E14	P15.5	I	FAST / PU1 / VEXT / ES	General-purpose input	
	GTM_TIM3_IN0_4			Mux input channel 0 of TIM module 3	
	GTM_TIM2_IN0_4			Mux input channel 0 of TIM module 2	
	ASCLIN1_ARXB			Receive input	
	I2C0_SDAC			Serial Data Input 2	
	QSPI2_MTSRA			Slave SPI data input	
	SCU_E_REQ4_3			ERU Channel 4 inputs 0 to 5 (0 is the LSB and 5 is the MSB)	
	P15.5			O0	General-purpose output
	GTM_TOUT76			O1	GTM muxed output
	ASCLIN1_ATX			O2	Transmit output
	IOM_MON2_13			O2	Monitor input 2
	IOM_REF2_13				Reference input 2
	QSPI2_MTSR			O3	Master SPI data output
	—			O4	Reserved
	MSC0_EN0			O5	Chip Select
	I2C0_SDA			O6	Serial Data Output
CCU60_CC61	O7	T12 PWM channel 61			
IOM_MON1_1		Monitor input 1			
IOM_REF1_5		Reference input 1			
A16	P15.6	I	FAST / PU1 / VEXT / ES	General-purpose input	
	GTM_TIM2_IN2_14			Mux input channel 2 of TIM module 2	
	GTM_TIM1_IN0_6			Mux input channel 0 of TIM module 1	
	GTM_TIM0_IN0_6			Mux input channel 0 of TIM module 0	
	QSPI2_MTSRB			Slave SPI data input	
	P15.6			O0	General-purpose output
	GTM_TOUT77			O1	GTM muxed output
	ASCLIN3_ATX			O2	Transmit output
	IOM_MON2_15			O2	Monitor input 2
	IOM_REF2_15				Reference input 2
	QSPI2_MTSR			O3	Master SPI data output
	—			O4	Reserved
	QSPI2_SCLK			O5	Master SPI clock output
	ASCLIN3_ASCLK			O6	Shift clock output
	CCU60_CC60			O7	T12 PWM channel 60
	IOM_MON1_2				Monitor input 1
IOM_REF1_6	Reference input 1				

TC37xEXT Pin Definition and Functions LFBGA-292 Package Pinning of

Table 2-28 Port 15 Functions (cont'd)

Ball	Symbol	Ctrl.	Buffer Type	Function
D15	P15.7	I	FAST / PU1 / VEXT / ES	General-purpose input
	GTM_TIM1_IN1_5			Mux input channel 1 of TIM module 1
	GTM_TIM0_IN1_5			Mux input channel 1 of TIM module 0
	ASCLIN3_ARXA			Receive input
	QSPI2_MRSTB			Master SPI data input
	P15.7	O0	General-purpose output	
	GTM_TOUT78	O1	GTM muxed output	
	ASCLIN3_ATX	O2	Transmit output	
	IOM_MON2_15	O3	Monitor input 2	
	IOM_REF2_15		Reference input 2	
	QSPI2_MRST		Slave SPI data output	
	IOM_MON2_2	Monitor input 2		
	IOM_REF2_2	Reference input 2		
	—	O4	Reserved	
	—	O5	Reserved	
	—	O6	Reserved	
	CCU60_COUT60	O7	T12 PWM channel 60	
IOM_MON1_3	Monitor input 1			
IOM_REF1_3	Reference input 1			
D14	P15.8	I	FAST / PU1 / VEXT / ES	General-purpose input
	GTM_TIM1_IN2_5			Mux input channel 2 of TIM module 1
	GTM_TIM0_IN2_5			Mux input channel 2 of TIM module 0
	QSPI2_SCLKB			Slave SPI clock inputs
	SCU_E_REQ5_0			ERU Channel 5 inputs 0 to 5 (0 is the LSB and 5 is the MSB)
	P15.8	O0	General-purpose output	
	GTM_TOUT79	O1	GTM muxed output	
	—	O2	Reserved	
	QSPI2_SCLK	O3	Master SPI clock output	
	—	O4	Reserved	
	—	O5	Reserved	
	ASCLIN3_ASCLK	O6	Shift clock output	
	CCU60_COUT61	O7	T12 PWM channel 61	
	IOM_MON1_4		Monitor input 1	
IOM_REF1_2	Reference input 1			

TC37xEXT Pin Definition and Functions LFBGA-292 Package Pinning of

Table 2-29 Port 20 Functions

Ball	Symbol	Ctrl.	Buffer Type	Function
H20	P20.0	I	FAST / PU1 / VEXT / ES	General-purpose input
	GTM_TIM1_IN6_7			Mux input channel 6 of TIM module 1
	GTM_TIM1_IN4_9			Mux input channel 4 of TIM module 1
	GTM_TIM0_IN6_7			Mux input channel 6 of TIM module 0
	CAN03_RXDC			CAN receive input node 3
	CCU_PAD_SYSCCLK			Sysclk input
	CAN21_RXDC			CAN receive input node 1
	CBS_TGI0			Trigger input
	SCU_E_REQ6_0			ERU Channel 6 inputs 0 to 5 (0 is the LSB and 5 is the MSB)
	GPT120_T6EUDA			Count direction control input of core timer T6
	P20.0	O0	General-purpose output	
	GTM_TOUT59	O1	GTM muxed output	
	ASCLIN3_ATX	O2	Transmit output	
	IOM_MON2_15		Monitor input 2	
	IOM_REF2_15		Reference input 2	
	ASCLIN3_ASCLK	O3	Shift clock output	
	—	O4	Reserved	
	HSCT0_SYSCCLK_OUT	O5	sys clock output	
	—	O6	Reserved	
	—	O7	Reserved	
CBS_TGO0	O	Trigger output		
G19	P20.1	I	SLOW / PU1 / VEXT / ES	General-purpose input
	GTM_TIM4_IN4_11			Mux input channel 4 of TIM module 4
	GTM_TIM3_IN3_5			Mux input channel 3 of TIM module 3
	GTM_TIM2_IN3_5			Mux input channel 3 of TIM module 2
	CBS_TGI1			Trigger input
	GTM_DTMA1_1			CDTM1_DTM4
	P20.1	O0	General-purpose output	
	GTM_TOUT60	O1	GTM muxed output	
	—	O2	Reserved	
	—	O3	Reserved	
	—	O4	Reserved	
	—	O5	Reserved	
	—	O6	Reserved	
	—	O7	Reserved	
	CBS_TGO1	O	Trigger output	

TC37xEXT Pin Definition and Functions LFBGA-292 Package Pinning of

Table 2-29 Port 20 Functions (cont'd)

Ball	Symbol	Ctrl.	Buffer Type	Function
H19	P20.2	I	S / PU / VEXT	General-purpose input This pin is latched at power on reset release to enter test mode.
	TESTMODE			Testmode Enable Input
G20	P20.3	I	SLOW / PU1 / VEXT / ES	General-purpose input
	GTM_TIM4_IN5_11			Mux input channel 5 of TIM module 4
	GTM_TIM3_IN4_5			Mux input channel 4 of TIM module 3
	GTM_TIM2_IN4_5			Mux input channel 4 of TIM module 2
	ASCLIN3_ARXC			Receive input
	GPT120_T6INA			Trigger/gate input of core timer T6
	P20.3	O0		General-purpose output
	GTM_TOUT61	O1		GTM muxed output
	ASCLIN3_ATX	O2		Transmit output
	IOM_MON2_15			Monitor input 2
	IOM_REF2_15			Reference input 2
	QSPI0_SLSO9	O3		Master slave select output
	QSPI2_SLSO9	O4		Master slave select output
	CAN03_TXD	O5		CAN transmit output node 3
	IOM_MON2_8			Monitor input 2
	IOM_REF2_8			Reference input 2
	CAN21_TXD	O6		CAN transmit output node 1
—	O7	Reserved		
F17	P20.6	I	SLOW / PU1 / VEXT / ES	General-purpose input
	GTM_TIM3_IN6_5			Mux input channel 6 of TIM module 3
	GTM_TIM2_IN6_5			Mux input channel 6 of TIM module 2
	CAN12_RXDA			CAN receive input node 2
	ASCLIN9_ARXE			Receive input
	P20.6	O0		General-purpose output
	GTM_TOUT62	O1		GTM muxed output
	ASCLIN1_ARTS	O2		Ready to send output
	QSPI0_SLSO8	O3		Master slave select output
	QSPI2_SLSO8	O4		Master slave select output
	—	O5		Reserved
	—	O6		Reserved
	—	O7		Reserved

TC37xEXT Pin Definition and Functions LFBGA-292 Package Pinning of

Table 2-29 Port 20 Functions (cont'd)

Ball	Symbol	Ctrl.	Buffer Type	Function
F19	P20.7	I	FAST / PU1 / VEXT / ES	General-purpose input
	GTM_TIM3_IN7_5			Mux input channel 7 of TIM module 3
	GTM_TIM2_IN7_5			Mux input channel 7 of TIM module 2
	GTM_TIM1_IN5_8			Mux input channel 5 of TIM module 1
	CAN00_RXDB			CAN receive input node 0
	ASCLIN1_ACTSA			Clear to send input
	ASCLIN9_ARXF			Receive input
	SDMMC0_DAT0_IN			read data in
	P20.7			O0
	GTM_TOUT63	O1	GTM muxed output	
	ASCLIN9_ATX	O2	Transmit output	
	—	O3	Reserved	
	—	O4	Reserved	
	CAN12_TXD	O5	CAN transmit output node 2	
	—	O6	Reserved	
	CCU61_COUT63	O7	T13 PWM channel 63	
	IOM_MON1_7	O	Monitor input 1	
	IOM_REF1_7		Reference input 1	
	SDMMC0_DAT0	O	write data out	
F20	P20.8	I	FAST / PU1 / VEXT / ES	General-purpose input
	GTM_TIM1_IN7_3			Mux input channel 7 of TIM module 1
	GTM_TIM0_IN7_3			Mux input channel 7 of TIM module 0
	SDMMC0_DAT1_IN			read data in
	P20.8	O0	General-purpose output	
	GTM_TOUT64	O1	GTM muxed output	
	ASCLIN1_ASLSO	O2	Slave select signal output	
	QSPI0_SLSO0	O3	Master slave select output	
	QSPI1_SLSO0	O4	Master slave select output	
	CAN00_TXD	O5	CAN transmit output node 0	
	IOM_MON2_5	O	Monitor input 2	
	IOM_REF2_5		Reference input 2	
	—		Reserved	
	CCU61_CC60	O7	T12 PWM channel 60	
	IOM_MON1_8	O	Monitor input 1	
	IOM_REF1_13		Reference input 1	
	SDMMC0_DAT1	O	write data out	

TC37xEXT Pin Definition and Functions LFBGA-292 Package Pinning of

Table 2-29 Port 20 Functions (cont'd)

Ball	Symbol	Ctrl.	Buffer Type	Function
E17	P20.9	I	FAST / PU1 / VEXT / ES	General-purpose input
	GTM_TIM3_IN5_5			Mux input channel 5 of TIM module 3
	GTM_TIM2_IN5_5			Mux input channel 5 of TIM module 2
	CAN03_RXDE			CAN receive input node 3
	ASCLIN1_ARXC			Receive input
	QSPIO_SLSIB			Slave select input
	SCU_E_REQ7_0			ERU Channel 7 inputs 0 to 5 (0 is the LSB and 5 is the MSB)
	P20.9	O0	General-purpose output	
	GTM_TOUT65	O1	GTM muxed output	
	—	O2	Reserved	
	QSPIO_SLSO1	O3	Master slave select output	
	QSPI1_SLSO1	O4	Master slave select output	
	—	O5	Reserved	
	—	O6	Reserved	
	CCU61_CC61	O7	T12 PWM channel 61	
IOM_MON1_9	Monitor input 1			
IOM_REF1_12	Reference input 1			
E19	P20.10	I	FAST / PU1 / VEXT / ES	General-purpose input
	GTM_TIM3_IN6_6			Mux input channel 6 of TIM module 3
	GTM_TIM2_IN6_6			Mux input channel 6 of TIM module 2
	SDMMC0_DAT2_IN			read data in
	P20.10	O0	General-purpose output	
	GTM_TOUT66	O1	GTM muxed output	
	ASCLIN1_ATX	O2	Transmit output	
	IOM_MON2_13		Monitor input 2	
	IOM_REF2_13		Reference input 2	
	QSPIO_SLSO6	O3	Master slave select output	
	QSPI2_SLSO7	O4	Master slave select output	
	CAN03_TXD	O5	CAN transmit output node 3	
	IOM_MON2_8		Monitor input 2	
	IOM_REF2_8		Reference input 2	
	ASCLIN1_ASCLK	O6	Shift clock output	
	CCU61_CC62	O7	T12 PWM channel 62	
	IOM_MON1_10		Monitor input 1	
	IOM_REF1_11		Reference input 1	
SDMMC0_DAT2	O	write data out		

TC37xEXT Pin Definition and Functions LFBGA-292 Package Pinning of

Table 2-29 Port 20 Functions (cont'd)

Ball	Symbol	Ctrl.	Buffer Type	Function
E20	P20.11	I	FAST / PU1 / VEXT / ES	General-purpose input
	GTM_TIM3_IN7_6			Mux input channel 7 of TIM module 3
	GTM_TIM2_IN7_6			Mux input channel 7 of TIM module 2
	QSPIO_SCLKA			Slave SPI clock inputs
	SDMMC0_DAT3_IN			read data in
	P20.11	O0		General-purpose output
	GTM_TOUT67	O1		GTM muxed output
	—	O2		Reserved
	QSPIO_SCLK	O3		Master SPI clock output
	—	O4		Reserved
	—	O5		Reserved
	—	O6		Reserved
	CCU61_COUT60	O7		T12 PWM channel 60
	IOM_MON1_11			Monitor input 1
	IOM_REF1_10			Reference input 1
SDMMC0_DAT3	O	write data out		
D19	P20.12	I	FAST / PU1 / VEXT / ES	General-purpose input
	GTM_TIM3_IN0_5			Mux input channel 0 of TIM module 3
	GTM_TIM2_IN0_5			Mux input channel 0 of TIM module 2
	QSPIO_MRSTA			Master SPI data input
	SDMMC0_DAT4_IN			read data in
	IOM_PIN_13	GPIO pad input to FPC		
	P20.12	O0		General-purpose output
	GTM_TOUT68	O1		GTM muxed output
	IOM_MON0_13	O2		Monitor input 0
	—			Reserved
	QSPIO_MRST			Slave SPI data output
	IOM_MON2_0	O3		Monitor input 2
	IOM_REF2_0			Reference input 2
	QSPIO_MTSR	O4		Master SPI data output
	—	O5		Reserved
	—	O6		Reserved
	CCU61_COUT61	O7		T12 PWM channel 61
	IOM_MON1_12			Monitor input 1
IOM_REF1_9	Reference input 1			
SDMMC0_DAT4	O	write data out		

TC37xEXT Pin Definition and Functions LFBGA-292 Package Pinning of

Table 2-29 Port 20 Functions (cont'd)

Ball	Symbol	Ctrl.	Buffer Type	Function
D20	P20.13	I	FAST / PU1 / VEXT / ES	General-purpose input
	GTM_TIM3_IN1_4			Mux input channel 1 of TIM module 3
	GTM_TIM2_IN1_4			Mux input channel 1 of TIM module 2
	QSPIO_SLSIA			Slave select input
	SDMMC0_DAT5_IN			read data in
	IOM_PIN_14			GPIO pad input to FPC
	P20.13			O0
	GTM_TOUT69	O1	GTM muxed output	
	IOM_MON0_14	O2	Monitor input 0	
	—		Reserved	
	QSPIO_SLSO2	O3	Master slave select output	
	QSPIO_SLSO2	O4	Master slave select output	
	QSPIO_SCLK	O5	Master SPI clock output	
	—	O6	Reserved	
	CCU61_COUT62	O7	T12 PWM channel 62	
	IOM_MON1_13	O	Monitor input 1	
	IOM_REF1_8		Reference input 1	
SDMMC0_DAT5	write data out			
C20	P20.14	I	FAST / PU1 / VEXT / ES	General-purpose input
	GTM_TIM3_IN2_4			Mux input channel 2 of TIM module 3
	GTM_TIM2_IN2_4			Mux input channel 2 of TIM module 2
	QSPIO_MTSRA			Slave SPI data input
	SDMMC0_DAT6_IN			read data in
	IOM_PIN_15			GPIO pad input to FPC
	DMU_FDEST			Enter destructive debug mode
	P20.14	O0	General-purpose output	
	GTM_TOUT70	O1	GTM muxed output	
	IOM_MON0_15	O2	Monitor input 0	
	—		Reserved	
	QSPIO_MTSR	O3	Master SPI data output	
	—	O4	Reserved	
	—	O5	Reserved	
	—	O6	Reserved	
	—	O7	Reserved	
	SDMMC0_DAT6	O	write data out	

TC37xEXT Pin Definition and Functions LFBGA-292 Package Pinning of

Table 2-30 Port 21 Functions

Ball	Symbol	Ctrl.	Buffer Type	Function
K17	P21.0	I	LVDS_R X/FAST/ PU1/ VEXT/ ES	General-purpose input
	GTM_TIM4_IN0_11			Mux input channel 0 of TIM module 4
	GTM_TIM3_IN4_6			Mux input channel 4 of TIM module 3
	GTM_TIM2_IN4_6			Mux input channel 4 of TIM module 2
	QSPI4_MRSTDN			Master SPI data input (LVDS N line)
	ASCLIN11_ARXC			Receive input
	P21.0	O0		General-purpose output
	GTM_TOUT51	O1		GTM muxed output
	ASCLIN11_ATX	O2		Transmit output
	—	O3		Reserved
	—	O4		Reserved
	—	O5		Reserved
	GETH1_PPS	O6		Pulse Per Second
	—	O7		Reserved
HSM_HSM1	O	Pin Output Value		
J17	P21.1	I	LVDS_R X/FAST/ PU1/ VEXT/ ES	General-purpose input
	GTM_TIM4_IN1_13			Mux input channel 1 of TIM module 4
	GTM_TIM3_IN5_6			Mux input channel 5 of TIM module 3
	GTM_TIM2_IN5_6			Mux input channel 5 of TIM module 2
	QSPI4_MRSTDN			Master SPI data input (LVDS P line)
	ASCLIN11_ARXD			Receive input
	GTM_DTMA4_1			CDTM4_DTM4
	P21.1	O0		General-purpose output
	GTM_TOUT52	O1		GTM muxed output
	—	O2		Reserved
	—	O3		Reserved
	—	O4		Reserved
	—	O5		Reserved
	—	O6		Reserved
—	O7	Reserved		
HSM_HSM2	O	Pin Output Value		

TC37xEXT Pin Definition and Functions LFBGA-292 Package Pinning of

Table 2-30 Port 21 Functions (cont'd)

Ball	Symbol	Ctrl.	Buffer Type	Function
K19	P21.2	I	LVDS_R X/FAST/ PU1/ VEXT/ ES	General-purpose input
	GTM_TIM5_IN4_11			Mux input channel 4 of TIM module 5
	GTM_TIM1_IN0_7			Mux input channel 0 of TIM module 1
	GTM_TIM0_IN0_7			Mux input channel 0 of TIM module 0
	QSPI2_MRSTCN			Master SPI data input (LVDS N line)
	SCU_EMGSTOP_POR T_B			Emergency stop Port Pin B input request
	ASCLIN3_ARXGN			Differential Receive input (low active)
	HSCT0_RXDN			Rx data
	QSPI4_MRSTCN			Master SPI data input (LVDS N line)
	ASCLIN11_ARXE			Receive input
	GTM_DTMA1_0			CDTM1_DTM4
	P21.2	O0		General-purpose output
	GTM_TOUT53	O1		GTM muxed output
	ASCLIN3_ASLSO	O2		Slave select signal output
	—	O3		Reserved
	—	O4		Reserved
	GETH_MDC	O5		MDIO clock
—	O6	Reserved		
—	O7	Reserved		
J19	P21.3	I	LVDS_R X/FAST/ PU1/ VEXT/ ES	General-purpose input
	GTM_TIM5_IN5_12			Mux input channel 5 of TIM module 5
	GTM_TIM1_IN1_6			Mux input channel 1 of TIM module 1
	GTM_TIM0_IN1_6			Mux input channel 1 of TIM module 0
	QSPI2_MRSTCP			Master SPI data input (LVDS P line)
	ASCLIN3_ARXGP			Differential Receive input (high active)
	GETH_MDIOD			MDIO Input
	HSCT0_RXDP			Rx data
	QSPI4_MRSTCP			Master SPI data input (LVDS P line)
	P21.3	O0		General-purpose output
	GTM_TOUT54	O1		GTM muxed output
	ASCLIN11_ASCLK	O2		Shift clock output
	—	O3		Reserved
	—	O4		Reserved
	—	O5		Reserved
	—	O6		Reserved
	—	O7		Reserved
GETH_MDIO	O	MDIO Output		

TC37xEXT Pin Definition and Functions LFBGA-292 Package Pinning of

Table 2-30 Port 21 Functions (cont'd)

Ball	Symbol	Ctrl.	Buffer Type	Function
K20	P21.4	I	LVDS_TX / FAST / PU1 / VEXT / ES6	General-purpose input
	GTM_TIM5_IN6_12			Mux input channel 6 of TIM module 5
	GTM_TIM1_IN2_6			Mux input channel 2 of TIM module 1
	GTM_TIM0_IN2_6			Mux input channel 2 of TIM module 0
	P21.4	O0		General-purpose output
	GTM_TOUT55	O1		GTM muxed output
	ASCLIN11_ASLSO	O2		Slave select signal output
	—	O3		Reserved
	—	O4		Reserved
	—	O5		Reserved
	—	O6		Reserved
	—	O7		Reserved
	H SCT0_TXDN	O		Tx data
J20	P21.5	I	LVDS_TX / FAST / PU1 / VEXT / ES6	General-purpose input
	GTM_TIM5_IN7_11			Mux input channel 7 of TIM module 5
	GTM_TIM1_IN3_6			Mux input channel 3 of TIM module 1
	GTM_TIM0_IN3_6			Mux input channel 3 of TIM module 0
	ASCLIN11_ARXF			Receive input
	P21.5	O0		General-purpose output
	GTM_TOUT56	O1		GTM muxed output
	ASCLIN3_ASCLK	O2		Shift clock output
	ASCLIN11_ATX	O3		Transmit output
	—	O4		Reserved
	—	O5		Reserved
	—	O6		Reserved
	—	O7		Reserved
H SCT0_TXDP	O	Tx data		

TC37xEXT Pin Definition and Functions LFBGA-292 Package Pinning of

Table 2-30 Port 21 Functions (cont'd)

Ball	Symbol	Ctrl.	Buffer Type	Function
H17	P21.6/TDI	I	FAST / PD / PU2 / VEXT / ES3	General-purpose input PD during Reset and in DAP/DAPE or JTAG mode. After Reset release and when not in DAP/DAPE or JTAG mode: PU. In Standby mode: HighZ. DAPE: DAPE1 Data I/O.
	GTM_TIM4_IN2_12			Mux input channel 2 of TIM module 4
	GTM_TIM1_IN4_8			Mux input channel 4 of TIM module 1
	GTM_TIM0_IN4_8			Mux input channel 4 of TIM module 0
	GPT120_T5EUDA			Count direction control input of timer T5
	ASCLIN3_ARXF			Receive input
	CBS_TGI2			Trigger input
	TDI			JTAG Module Data Input
	P21.6	O0	General-purpose output	
	GTM_TOUT57	O1	GTM muxed output	
	ASCLIN3_ASLSO	O2	Slave select signal output	
	—	O3	Reserved	
	—	O4	Reserved	
	—	O5	Reserved	
	—	O6	Reserved	
	GPT120_T3OUT	O7	External output for overflow/underflow detection of core timer T3	
	CBS_TGO2	O	Trigger output	
	DAP3	I/O	DAP: DAP3 Data I/O	
	DAPE1	I/O	DAPE: DAPE1 Data I/O	

TC37xEXT Pin Definition and Functions LFBGA-292 Package Pinning of

Table 2-30 Port 21 Functions (cont'd)

Ball	Symbol	Ctrl.	Buffer Type	Function
H16	P21.7/TDO	I	FAST / PU2 / VEXT / ES4	General-purpose input DAP: DAP2 Data I/O; DAPE: DAPE2 Data I/O.
	GTM_TIM4_IN3_12			Mux input channel 3 of TIM module 4
	GTM_TIM1_IN5_7			Mux input channel 5 of TIM module 1
	GTM_TIM0_IN5_7			Mux input channel 5 of TIM module 0
	GPT120_T5INA			Trigger/gate input of timer T5
	CBS_TGI3			Trigger input
	GETH_RXERB			Receive Error MII
	P21.7	O0	General-purpose output	
	GTM_TOUT58	O1	GTM muxed output	
	ASCLIN3_ATX	O2	Transmit output	
	IOM_MON2_15		Monitor input 2	
	IOM_REF2_15		Reference input 2	
	ASCLIN3_ASCLK	O3	Shift clock output	
	—	O4	Reserved	
	—	O5	Reserved	
	—	O6	Reserved	
	GPT120_T6OUT	O7	External output for overflow/underflow detection of core timer T6	
	CBS_TGO3	O	Trigger output	
	DAP2	I/O	DAP: DAP2 Data I/O	
	DAPE2	I/O	DAPE: DAPE2 Data I/O	
TDO	O	JTAG Module Data Output		

TC37xEXT Pin Definition and Functions LFBGA-292 Package Pinning of

Table 2-31 Port 22 Functions

Ball	Symbol	Ctrl.	Buffer Type	Function	
L16	P22.0	I	LVDS_TX / FAST / PU1 / VFLEX2 / ES6	General-purpose input	
	GTM_TIM1_IN1_7			Mux input channel 1 of TIM module 1	
	GTM_TIM0_IN1_7			Mux input channel 1 of TIM module 0	
	QSPI4_MTSRB			Slave SPI data input	
	ASCLIN6_ARXE			Receive input	
	GETH1_CRSDVB			Carrier Sense / Data Valid combi-signal for RMII	
	GETH1_RXDVB			Receive Data Valid MII	
	GETH1_CRSA			Carrier Sense MII	
	P22.0			O0	General-purpose output
	GTM_TOUT47	O1	GTM muxed output		
	ASCLIN3_ATXN	O2	Differential Transmit output (low active)		
	QSPI4_MTSR	O3	Master SPI data output		
	QSPI4_SCLKN	O4	Master SPI clock output (LVDS N line)		
	MSC1_FCLN	O5	Shift-clock inverted part of the differential signal		
	—	O6	Reserved		
	ASCLIN6_ATX	O7	Transmit output		
L17	P22.1	I	LVDS_TX / FAST / PU1 / VFLEX2 / ES6	General-purpose input	
	GTM_TIM1_IN0_8			Mux input channel 0 of TIM module 1	
	GTM_TIM0_IN0_8			Mux input channel 0 of TIM module 0	
	QSPI4_MRSTB			Master SPI data input	
	ASCLIN7_ARXE			Receive input	
	GETH1_RXERA			Receive Error MII	
	P22.1			O0	General-purpose output
	GTM_TOUT48			O1	GTM muxed output
	ASCLIN3_ATXP			O2	Differential Transmit output (high active)
	QSPI4_MRST	O3	Slave SPI data output		
	IOM_MON2_4		Monitor input 2		
	IOM_REF2_4		Reference input 2		
	QSPI4_SCLKP	O4	Master SPI clock output (LVDS P line)		
	MSC1_FCLP	O5	Shift-clock direct part of the differential signal		
	—	O6	Reserved		
	ASCLIN7_ATX	O7	Transmit output		

TC37xEXT Pin Definition and Functions LFBGA-292 Package Pinning of

Table 2-31 Port 22 Functions (cont'd)

Ball	Symbol	Ctrl.	Buffer Type	Function
R20	P22.2	I	LVDS_TX / FAST / PU1 / VEXT / ES6	General-purpose input
	GTM_TIM1_IN3_7			Mux input channel 3 of TIM module 1
	GTM_TIM0_IN3_7			Mux input channel 3 of TIM module 0
	QSPI4_SLSIB			Slave select input
	GETH1_COLA			Collision MII
	P22.2	O0	General-purpose output	
	GTM_TOUT49	O1	GTM muxed output	
	ASCLIN5_ATX	O2	Transmit output	
	QSPI4_SLSO3	O3	Master slave select output	
	QSPI4_MTSRN	O4	Master SPI data output (LVDS N line)	
	MSC1_SON	O5	Data output - inverted part of the differential signal	
	—	O6	Reserved	
	—	O7	Reserved	
R19	P22.3	I	LVDS_TX / FAST / PU1 / VEXT / ES6	General-purpose input
	GTM_TIM1_IN4_4			Mux input channel 4 of TIM module 1
	GTM_TIM0_IN4_4			Mux input channel 4 of TIM module 0
	QSPI4_SCLKB			Slave SPI clock inputs
	ASCLIN5_ARXC			Receive input
	P22.3	O0	General-purpose output	
	GTM_TOUT50	O1	GTM muxed output	
	—	O2	Reserved	
	QSPI4_SCLK	O3	Master SPI clock output	
	QSPI4_MTSRP	O4	Master SPI data output (LVDS P line)	
	MSC1_SOP	O5	Data output - direct part of the differential signal	
	—	O6	Reserved	
	—	O7	Reserved	

TC37xEXT Pin Definition and Functions LFBGA-292 Package Pinning of

Table 2-31 Port 22 Functions (cont'd)

Ball	Symbol	Ctrl.	Buffer Type	Function	
P16	P22.4	I	SLOW / RGMII_In put / PU1 / VFLEX2 / ES	General-purpose input	
	GTM_TIM3_IN0_8			Mux input channel 0 of TIM module 3	
	ASCLIN7_ARXF			Receive input	
	GETH1_RXD0A			Receive Data 0 MII, RMII and RGMII (RGMII can use RXD0A only)	
	GTM_DTMA3_0			CDTM3_DTM4	
	P22.4			O0	General-purpose output
	GTM_TOUT130			O1	GTM muxed output
	ASCLIN4_ASLSO			O2	Slave select signal output
	—			O3	Reserved
	QSPIO_SLSO12			O4	Master slave select output
	—			O5	Reserved
	CAN13_TXD			O6	CAN transmit output node 3
	—			O7	Reserved
P17	P22.5	I	SLOW / RGMII_In put / PU1 / VFLEX2 / ES	General-purpose input	
	GTM_TIM3_IN1_7			Mux input channel 1 of TIM module 3	
	QSPIO_MTSRC			Slave SPI data input	
	CAN13_RXDC			CAN receive input node 3	
	GETH1_REFCLKA			Reference Clock input for RMII (50 MHz)	
	GETH1_TXCLKB			Transmit Clock Input for MII	
	GETH1_RXCLKA			Receive Clock MII	
	P22.5			O0	General-purpose output
	GTM_TOUT131			O1	GTM muxed output
	ASCLIN4_ATX			O2	Transmit output
	—			O3	Reserved
	QSPIO_MTSR			O4	Master SPI data output
	—			O5	Reserved
—	O6	Reserved			
—	O7	Reserved			

TC37xEXT Pin Definition and Functions LFBGA-292 Package Pinning of

Table 2-31 Port 22 Functions (cont'd)

Ball	Symbol	Ctrl.	Buffer Type	Function
N16	P22.6	I	SLOW / RGMII_In put / PU1 / VFLEX2 / ES	General-purpose input
	GTM_TIM3_IN2_6			Mux input channel 2 of TIM module 3
	GTM_TIM2_IN6_14			Mux input channel 6 of TIM module 2
	QSPI0_MRSTC			Master SPI data input
	ASCLIN4_ARXC			Receive input
	GETH1_CRSDVA			Carrier Sense / Data Valid combi-signal for RMII
	GETH1_RXDVA			Receive Data Valid MII
	GETH1_CRSB			Carrier Sense MII
	GETH1_RCTLA			Receive Control for RGMII
	P22.6	O0	General-purpose output	
	GTM_TOUT132	O1	GTM muxed output	
	—	O2	Reserved	
	—	O3	Reserved	
	QSPI0_MRST	O4	Slave SPI data output	
	IOM_MON2_0		Monitor input 2	
	IOM_REF2_0		Reference input 2	
	CAN21_TXD	O5	CAN transmit output node 1	
—	O6	Reserved		
—	O7	Reserved		
N17	P22.7	I	SLOW / RGMII_In put / PU1 / VFLEX2 / ES	General-purpose input
	GTM_TIM3_IN3_7			Mux input channel 3 of TIM module 3
	QSPI0_SCLKC			Slave SPI clock inputs
	CAN21_RXDF			CAN receive input node 1
	GETH1_TXCLKA			Transmit Clock Input for MII
	GETH1_GREFCLK			Gigabit Reference Clock input for RGMII (125 MHz high precision)
	P22.7	O0	General-purpose output	
	GTM_TOUT133	O1	GTM muxed output	
	ASCLIN4_ASCLK	O2	Shift clock output	
	—	O3	Reserved	
	QSPI0_SCLK	O4	Master SPI clock output	
	—	O5	Reserved	
	—	O6	Reserved	
	—	O7	Reserved	

TC37xEXT Pin Definition and Functions LFBGA-292 Package Pinning of

Table 2-31 Port 22 Functions (cont'd)

Ball	Symbol	Ctrl.	Buffer Type	Function
M16	P22.8	I	SLOW / PU1 / VFLEX2 / ES	General-purpose input
	GTM_TIM5_IN0_4			Mux input channel 0 of TIM module 5
	GTM_TIM3_IN4_7			Mux input channel 4 of TIM module 3
	QSPIO_SCLKB			Slave SPI clock inputs
	GETH1_RXCLKC			Receive Clock MII
	P22.8	O0	General-purpose output	
	GTM_TOUT134	O1	GTM muxed output	
	ASCLIN5_ASCLK	O2	Shift clock output	
	—	O3	Reserved	
	QSPIO_SCLK	O4	Master SPI clock output	
	CAN22_TXD	O5	CAN transmit output node 2	
	GETH1_MDC	O6	MDIO clock	
	—	O7	Reserved	
M17	P22.9	I	SLOW / PU1 / VFLEX2 / ES	General-purpose input
	GTM_TIM5_IN1_10			Mux input channel 1 of TIM module 5
	GTM_TIM3_IN5_7			Mux input channel 5 of TIM module 3
	QSPIO_MRSTB			Master SPI data input
	ASCLIN4_ARXD			Receive input
	CAN22_RXDE			CAN receive input node 2
	GETH1_MDIOC			MDIO Input
	GTM_DTMA3_1			CDTM3_DTM4
	P22.9			O0
	GTM_TOUT135	O1	GTM muxed output	
	—	O2	Reserved	
	—	O3	Reserved	
	QSPIO_MRST	O4	Slave SPI data output	
	IOM_MON2_0		Monitor input 2	
	IOM_REF2_0		Reference input 2	
	—		O5	Reserved
	—	O6	Reserved	
	—	O7	Reserved	
GETH1_MDIO	O	MDIO Output		

TC37xEXT Pin Definition and Functions LFBGA-292 Package Pinning of

Table 2-31 Port 22 Functions (cont'd)

Ball	Symbol	Ctrl.	Buffer Type	Function
P20	P22.10	I	RFAST / PU1 / VFLEX2 / ES	General-purpose input
	GTM_TIM5_IN2_8			Mux input channel 2 of TIM module 5
	GTM_TIM3_IN6_7			Mux input channel 6 of TIM module 3
	QSPIO_MTSRB			Slave SPI data input
	P22.10	O0		General-purpose output
	GTM_TOUT136	O1		GTM muxed output
	ASCLIN4_ATX	O2		Transmit output
	—	O3		Reserved
	QSPIO_MTSR	O4		Master SPI data output
	CAN23_TXD	O5		CAN transmit output node 3
	GETH1_TXD0	O6		Transmit Data
	—	O7		Reserved
P19	P22.11	I	RFAST / PU1 / VFLEX2 / ES	General-purpose input
	GTM_TIM5_IN3_10			Mux input channel 3 of TIM module 5
	GTM_TIM3_IN7_7			Mux input channel 7 of TIM module 3
	CAN23_RXDE			CAN receive input node 3
	P22.11	O0		General-purpose output
	GTM_TOUT137	O1		GTM muxed output
	ASCLIN4_ASLSO	O2		Slave select signal output
	—	O3		Reserved
	QSPIO_SLSO10	O4		Master slave select output
	—	O5		Reserved
	GETH1_TXEN	O6		Transmit Enable MII and RMII
	GETH1_TCTL			Transmit Control for RGMII
—	O7	Reserved		
T19	P22.12	I	RFAST / PU1 / VFLEX2 / ES	General-purpose input
	GETH1_RXCLKB			Receive Clock MII
	P22.12	O0		General-purpose output
	—	O1		Reserved
	—	O2		Reserved
	—	O3		Reserved
	—	O4		Reserved
	—	O5		Reserved
	GETH1_TXER	O6		Transmit Error MII
	GETH1_TXCLK	O7		Transmit Clock Output for RGMII

TC37xEXT Pin Definition and Functions LFBGA-292 Package Pinning of

Table 2-32 Port 23 Functions

Ball	Symbol	Ctrl.	Buffer Type	Function
U19	P23.1	I	FAST / PU1 / VEXT / ES	General-purpose input
	GTM_TIM1_IN6_4			Mux input channel 6 of TIM module 1
	GTM_TIM0_IN6_4			Mux input channel 6 of TIM module 0
	MSC1_SDI0			Upstream assynchronous input signal
	ASCLIN6_ARXF			Receive input
	P23.1	O0		General-purpose output
	GTM_TOUT42	O1		GTM muxed output
	ASCLIN1_ARTS	O2		Ready to send output
	QSPI4_SLSO6	O3		Master slave select output
	GTM_CLK0	O4		CGM generated clock
	CAN10_TXD	O5		CAN transmit output node 0
	CCU_EXTCLK0	O6		External Clock 0
	ASCLIN6_ASCLK	O7		Shift clock output
V20	P23.2	I	RFAST / PU1 / VFLEX2 / ES	General-purpose input
	GTM_TIM1_IN6_5			Mux input channel 6 of TIM module 1
	GTM_TIM0_IN6_5			Mux input channel 6 of TIM module 0
	ASCLIN7_ARXC			Receive input
	P23.2	O0		General-purpose output
	GTM_TOUT43	O1		GTM muxed output
	—	O2		Reserved
	—	O3		Reserved
	CAN23_TXD	O4		CAN transmit output node 3
	CAN12_TXD	O5		CAN transmit output node 2
	GETH1_TXD3	O6		Transmit Data
	—	O7		Reserved

TC37xEXT Pin Definition and Functions LFBGA-292 Package Pinning of

Table 2-32 Port 23 Functions (cont'd)

Ball	Symbol	Ctrl.	Buffer Type	Function
U20	P23.3	I	RFAST / PU1 / VFLEX2 / ES	General-purpose input
	GTM_TIM1_IN7_4			Mux input channel 7 of TIM module 1
	GTM_TIM0_IN7_4			Mux input channel 7 of TIM module 0
	MSC1_INJ0			Injection signal from port
	ASCLIN6_ARXA			Receive input
	CAN12_RXDC			CAN receive input node 2
	CAN23_RXDB			CAN receive input node 3
	P23.3			O0
	GTM_TOUT44	O1	GTM muxed output	
	ASCLIN7_ATX	O2	Transmit output	
	—	O3	Reserved	
	—	O4	Reserved	
	—	O5	Reserved	
	GETH1_TXD2	O6	Transmit Data	
—	O7	Reserved		
T20	P23.4	I	RFAST / PU1 / VFLEX2 / ES	General-purpose input
	GTM_TIM1_IN7_5			Mux input channel 7 of TIM module 1
	GTM_TIM0_IN7_5			Mux input channel 7 of TIM module 0
	P23.4	O0	General-purpose output	
	GTM_TOUT45	O1	GTM muxed output	
	ASCLIN6_ASLSO	O2	Slave select signal output	
	QSPI4_SLSO5	O3	Master slave select output	
	—	O4	Reserved	
	MSC1_EN0	O5	Chip Select	
	GETH1_TXD1	O6	Transmit Data	
	—	O7	Reserved	

TC37xEXT Pin Definition and Functions LFBGA-292 Package Pinning of

Table 2-32 Port 23 Functions (cont'd)

Ball	Symbol	Ctrl.	Buffer Type	Function
T17	P23.5	I	FAST / RGMII_In put / PU1 / VFLEX2 / ES	General-purpose input
	GTM_TIM1_IN2_7			Mux input channel 2 of TIM module 1
	GTM_TIM0_IN2_7			Mux input channel 2 of TIM module 0
	GETH1_RXD3A			Receive Data 3 MII and RGMII (RGMII can use RXD3A only)
	P23.5	O0	General-purpose output	
	GTM_TOUT46	O1	GTM muxed output	
	ASCLIN6_ATX	O2	Transmit output	
	QSPI4_SLSO4	O3	Master slave select output	
	—	O4	Reserved	
	MSC1_EN1	O5	Chip Select	
	CAN22_TXD	O6	CAN transmit output node 2	
—	O7	Reserved		
R17	P23.6	I	SLOW / RGMII_In put / PU1 / VFLEX2 / ES	General-purpose input
	GTM_TIM4_IN2_7			Mux input channel 2 of TIM module 4
	GTM_TIM1_IN2_10			Mux input channel 2 of TIM module 1
	CAN22_RXDC			CAN receive input node 2
	GETH1_RXD2A			Receive Data 2 MII and RGMII (RGMII can use RXD2A only)
	P23.6	O0	General-purpose output	
	GTM_TOUT138	O1	GTM muxed output	
	—	O2	Reserved	
	—	O3	Reserved	
	QSPI0_SLSO11	O4	Master slave select output	
	CAN11_TXD	O5	CAN transmit output node 1	
—	O6	Reserved		
—	O7	Reserved		

TC37xEXT Pin Definition and Functions LFBGA-292 Package Pinning of

Table 2-32 Port 23 Functions (cont'd)

Ball	Symbol	Ctrl.	Buffer Type	Function
R16	P23.7	I	SLOW / RGMII_Input / PU1 / VFLEX2 / ES	General-purpose input
	GTM_TIM4_IN3_7			Mux input channel 3 of TIM module 4
	GTM_TIM1_IN3_10			Mux input channel 3 of TIM module 1
	CAN11_RXDC			CAN receive input node 1
	GETH1_RXD1A			Receive Data 1 MII, RMII and RGMII (RGMII can use RXD1A only)
	P23.7	O0	General-purpose output	
	GTM_TOUT139	O1	GTM muxed output	
	—	O2	Reserved	
	—	O3	Reserved	
	—	O4	Reserved	
	—	O5	Reserved	
	—	O6	Reserved	
	—	O7	Reserved	

Table 2-33 Port 32 Functions

Ball	Symbol	Ctrl.	Buffer Type	Function
Y17	P32.0	I	SLOW / PU1 / VEXT / ES	General-purpose input P32.0 / SMPS mode: analog output. External Pass Device gate control for EVRC
	GTM_TIM3_IN2_5			Mux input channel 2 of TIM module 3
	GTM_TIM2_IN2_5			Mux input channel 2 of TIM module 2
	P32.0	O0	General-purpose output	
	GTM_TOUT36	O1	GTM muxed output	
	—	O2	Reserved	
	—	O3	Reserved	
	—	O4	Reserved	
	—	O5	Reserved	
	—	O6	Reserved	
	—	O7	Reserved	

TC37xEXT Pin Definition and Functions LFBGA-292 Package Pinning of

Table 2-33 Port 32 Functions (cont'd)

Ball	Symbol	Ctrl.	Buffer Type	Function
W17	P32.1	I	SLOW / PU1 / VEXT / ES	General-purpose input P32.1 / External Pass Device gate control for EVRC
	GTM_TIM3_IN3_15			Mux input channel 3 of TIM module 3
	P32.1	O0		General-purpose output
	GTM_TOUT37	O1		GTM muxed output
	—	O2		Reserved
	—	O3		Reserved
	—	O4		Reserved
	—	O5		Reserved
	—	O6		Reserved
	—	O7		Reserved
Y18	P32.2	I	SLOW / PU1 / VEXT / ES	General-purpose input
	GTM_TIM1_IN3_8			Mux input channel 3 of TIM module 1
	GTM_TIM0_IN3_8			Mux input channel 3 of TIM module 0
	CAN03_RXDB			CAN receive input node 3
	ASCLIN3_ARXD			Receive input
	CAN21_RXDD			CAN receive input node 1
	P32.2			O0
	GTM_TOUT38	O1		GTM muxed output
	ASCLIN3_ATX	O2		Transmit output
	IOM_MON2_15			Monitor input 2
	IOM_REF2_15			Reference input 2
	—			O3
	—	O4		Reserved
	—	O5		Reserved
	PMS_DCDCSYNCO	O6		DC-DC synchronization output
—	O7	Reserved		

TC37xEXT Pin Definition and Functions LFBGA-292 Package Pinning of

Table 2-33 Port 32 Functions (cont'd)

Ball	Symbol	Ctrl.	Buffer Type	Function
Y19	P32.3	I	SLOW / PU1 / VEXT / ES	General-purpose input
	GTM_TIM1_IN4_5			Mux input channel 4 of TIM module 1
	GTM_TIM0_IN4_5			Mux input channel 4 of TIM module 0
	P32.3	O0		General-purpose output
	GTM_TOUT39	O1		GTM muxed output
	ASCLIN3_ATX	O2		Transmit output
	IOM_MON2_15			Monitor input 2
	IOM_REF2_15	O3		Reference input 2
	—			Reserved
	ASCLIN3_ASCLK			O4
	CAN03_TXD	O5		CAN transmit output node 3
	IOM_MON2_8	O6		Monitor input 2
	IOM_REF2_8			Reference input 2
	CAN21_TXD	O6		CAN transmit output node 1
	—	O7		Reserved
W18	P32.4	I	FAST / PU1 / VEXT / ES	General-purpose input
	GTM_TIM1_IN5_5			Mux input channel 5 of TIM module 1
	GTM_TIM0_IN5_5			Mux input channel 5 of TIM module 0
	ASCLIN1_ACTSB			Clear to send input
	MSC1_SDI2			Upstream asynchronous input signal
	P32.4	O0		General-purpose output
	GTM_TOUT40	O1		GTM muxed output
	—	O2		Reserved
	—	O3		Reserved
	GTM_CLK1	O4		CGM generated clock
	MSC1_EN0	O5		Chip Select
	CCU_EXTCLK1	O6		External Clock 1
	CCU60_COUT63	O7		T13 PWM channel 63
	IOM_MON1_6			Monitor input 1
	IOM_REF1_0	O		Reference input 1
PMS_DCDCSYNCO	DC-DC synchronization output			

TC37xEXT Pin Definition and Functions LFBGA-292 Package Pinning of

Table 2-33 Port 32 Functions (cont'd)

Ball	Symbol	Ctrl.	Buffer Type	Function	
T15	P32.5	I	SLOW / PU1 / VEXT / ES	General-purpose input	
	GTM_TIM5_IN5_9			Mux input channel 5 of TIM module 5	
	GTM_TIM4_IN1_14			Mux input channel 1 of TIM module 4	
	GTM_TIM3_IN5_8			Mux input channel 5 of TIM module 3	
	SENT_SENT10C			Receive input channel 10	
	P32.5			O0	General-purpose output
	GTM_TOUT140			O1	GTM muxed output
	ASCLIN2_ATX			O2	Transmit output
	IOM_MON2_14			O3	Monitor input 2
	IOM_REF2_14				Reference input 2
	—				Reserved
	—				Reserved
	—			O4	Reserved
	—			O5	Reserved
	CAN02_TXD			O6	CAN transmit output node 2
	IOM_MON2_7			O7	Monitor input 2
IOM_REF2_7	Reference input 2				
—	Reserved				
U15	P32.6	I	SLOW / PU1 / VEXT / ES	General-purpose input	
	GTM_TIM5_IN6_9			Mux input channel 6 of TIM module 5	
	GTM_TIM4_IN4_15			Mux input channel 4 of TIM module 4	
	GTM_TIM3_IN6_8			Mux input channel 6 of TIM module 3	
	CAN02_RXDC			CAN receive input node 2	
	CBS_TGI4			Trigger input	
	ASCLIN2_ARXF			Receive input	
	ASCLIN6_ARXC			Receive input	
	SENT_SENT11C			Receive input channel 11	
	P32.6			O0	General-purpose output
	GTM_TOUT141			O1	GTM muxed output
	—			O2	Reserved
	—			O3	Reserved
	QSPI2_SLSO12			O4	Master slave select output
	CAN22_TXD			O5	CAN transmit output node 2
	—			O6	Reserved
—	O7	Reserved			
CBS_TGO4	O	Trigger output			

TC37xEXT Pin Definition and Functions LFBGA-292 Package Pinning of

Table 2-33 Port 32 Functions (cont'd)

Ball	Symbol	Ctrl.	Buffer Type	Function
U16	P32.7	I	SLOW / PU1 / VEXT / ES	General-purpose input
	GTM_TIM5_IN7_8			Mux input channel 7 of TIM module 5
	GTM_TIM4_IN0_15			Mux input channel 0 of TIM module 4
	GTM_TIM3_IN7_8			Mux input channel 7 of TIM module 3
	CBS_TGI5			Trigger input
	CAN22_RXDB			CAN receive input node 2
	SENT_SENT12C			Receive input channel 12
	P32.7			O0
	GTM_TOUT142	O1	GTM muxed output	
	ASCLIN6_ATX	O2	Transmit output	
	—	O3	Reserved	
	—	O4	Reserved	
	—	O5	Reserved	
	—	O6	Reserved	
	—	O7	Reserved	
	CBS_TGO5	O	Trigger output	

TC37xEXT Pin Definition and Functions LFBGA-292 Package Pinning of

Table 2-34 Port 33 Functions

Ball	Symbol	Ctrl.	Buffer Type	Function
W10	P33.0	I	SLOW / PU1 / VEVRSB / ES5	General-purpose input
	GTM_TIM3_IN0_13			Mux input channel 0 of TIM module 3
	GTM_TIM1_IN4_6			Mux input channel 4 of TIM module 1
	GTM_TIM0_IN4_6			Mux input channel 4 of TIM module 0
	EDSADC_ITR0E			Trigger/Gate input, channel 0
	SENT_SENT13C			Receive input channel 13
	IOM_PIN_0			GPIO pad input to FPC
	GTM_DTMT1_2			CDTM1_DTM0
	EVADC_G10CH7	AI		Analog input channel 7, group 10
	P33.0	O0	General-purpose output	
	GTM_TOUT22	O1	GTM muxed output	
	IOM_MON0_0		Monitor input 0	
	IOM_GTM_0		GTM-provided inputs to EXOR combiner	
	ASCLIN5_ATX	O2	Transmit output	
	—	O3	Reserved	
	—	O4	Reserved	
	—	O5	Reserved	
	EVADC_FC2BFLOUT	O6	Boundary flag output, FC channel 2	
	—	O7	Reserved	

TC37xEXT Pin Definition and Functions LFBGA-292 Package Pinning of

Table 2-34 Port 33 Functions (cont'd)

Ball	Symbol	Ctrl.	Buffer Type	Function
Y10	P33.1	I	SLOW / PU1 / VEVRSB / ES5	General-purpose input
	GTM_TIM3_IN1_15			Mux input channel 1 of TIM module 3
	GTM_TIM1_IN5_6			Mux input channel 5 of TIM module 1
	GTM_TIM0_IN5_6			Mux input channel 5 of TIM module 0
	EDSADC_ITR1E			Trigger/Gate input, channel 1
	PSI5_RX0C			RXD inputs (receive data) channel 0
	EDSADC_DSCIN2B			Modulator clock input, channel 2
	SENT_SENT9C			Receive input channel 9
	ASCLIN8_ARXC			Receive input
	IOM_PIN_1			GPIO pad input to FPC
	EVADC_G10CH6			AI
	P33.1	O0	General-purpose output	
	GTM_TOUT23	O1	GTM muxed output	
	IOM_MON0_1		Monitor input 0	
	IOM_GTM_1		GTM-provided inputs to EXOR combiner	
	ASCLIN3_ASLSO	O2	Slave select signal output	
	QSPI2_SCLK	O3	Master SPI clock output	
	EDSADC_DSCOUT2	O4	Modulator clock output	
	EVADC_EMUX02	O5	Control of external analog multiplexer interface 0	
	—	O6	Reserved	
—	O7	Reserved		

TC37xEXT Pin Definition and Functions LFBGA-292 Package Pinning of

Table 2-34 Port 33 Functions (cont'd)

Ball	Symbol	Ctrl.	Buffer Type	Function
W11	P33.2	I	SLOW / PU1 / VEVRSB / ES5	General-purpose input
	GTM_TIM3_IN2_14			Mux input channel 2 of TIM module 3
	GTM_TIM1_IN6_6			Mux input channel 6 of TIM module 1
	GTM_TIM0_IN6_6			Mux input channel 6 of TIM module 0
	EDSADC_ITR2E			Trigger/Gate input, channel 2
	SENT_SENT8C			Receive input channel 8
	EDSADC_DSDIN2B			Digital datastream input, channel 2
	IOM_PIN_2			GPIO pad input to FPC
	EVADC_G10CH5			AI
	P33.2	O0	General-purpose output	
	GTM_TOUT24	O1	GTM muxed output	
	IOM_MON0_2		Monitor input 0	
	IOM_GTM_2		GTM-provided inputs to EXOR combiner	
	ASCLIN3_ASCLK		O2	Shift clock output
	QSPI2_SLSO10	O3	Master slave select output	
	PSI5_TX0	O4	TXD outputs (send data)	
	IOM_MON1_14		Monitor input 1	
	IOM_REF1_14		Reference input 1	
	EVADC_EMUX01	O5	Control of external analog multiplexer interface 0	
	EVADC_FC3BFLOUT	O6	Boundary flag output, FC channel 3	
—	O7	Reserved		

TC37xEXT Pin Definition and Functions LFBGA-292 Package Pinning of

Table 2-34 Port 33 Functions (cont'd)

Ball	Symbol	Ctrl.	Buffer Type	Function
Y11	P33.3	I	SLOW / PU1 / VEVRSB / ES5	General-purpose input
	GTM_TIM3_IN3_12			Mux input channel 3 of TIM module 3
	GTM_TIM1_IN7_6			Mux input channel 7 of TIM module 1
	GTM_TIM0_IN7_6			Mux input channel 7 of TIM module 0
	PSI5_RX1C			RXD inputs (receive data) channel 1
	SENT_SENT7C			Receive input channel 7
	EDSADC_DSCIN1B			Modulator clock input, channel 1
	IOM_PIN_3			GPIO pad input to FPC
	EVADC_G10CH4			AI
	P33.3	O0	General-purpose output	
	GTM_TOUT25	O1	GTM muxed output	
	IOM_MON0_3		Monitor input 0	
	IOM_GTM_3		GTM-provided inputs to EXOR combiner	
	ASCLIN5_ASCLK	O2	Shift clock output	
	QSPI4_SLSO2	O3	Master slave select output	
	EDSADC_DSCOUT1	O4	Modulator clock output	
	EVADC_EMUX00	O5	Control of external analog multiplexer interface 0	
	—	O6	Reserved	
	—	O7	Reserved	

TC37xEXT Pin Definition and Functions LFBGA-292 Package Pinning of

Table 2-34 Port 33 Functions (cont'd)

Ball	Symbol	Ctrl.	Buffer Type	Function
W12	P33.4	I	SLOW / PU1 / VEVRSB / ES5	General-purpose input
	GTM_TIM4_IN4_10			Mux input channel 4 of TIM module 4
	GTM_TIM1_IN0_10			Mux input channel 0 of TIM module 1
	GTM_TIM0_IN0_10			Mux input channel 0 of TIM module 0
	EDSADC_ITR0F			Trigger/Gate input, channel 0
	SENT_SENT6C			Receive input channel 6
	EDSADC_DSDIN1B			Digital datastream input, channel 1
	CCU61_CTRAPC			Trap input capture
	ASCLIN5_ARXB			Receive input
	IOM_PIN_4			GPIO pad input to FPC
	GTM_DTMT2_0			CDTM2_DTM0
	EVADC_G10CH3			AI
	P33.4	O0	General-purpose output	
	GTM_TOUT26	O1	GTM muxed output	
	IOM_MON0_4		Monitor input 0	
	IOM_GTM_4		GTM-provided inputs to EXOR combiner	
	ASCLIN2_ARTS	O2	Ready to send output	
	QSPI2_SLSO12	O3	Master slave select output	
	PSI5_TX1	O4	TXD outputs (send data)	
	IOM_MON1_15		Monitor input 1	
EVADC_EMUX12	O5		Control of external analog multiplexer interface 1	
EVADC_FC0BFLOUT	O6		Boundary flag output, FC channel 0	
CAN13_TXD	O7	CAN transmit output node 3		

TC37xEXT Pin Definition and Functions LFBGA-292 Package Pinning of

Table 2-34 Port 33 Functions (cont'd)

Ball	Symbol	Ctrl.	Buffer Type	Function
Y12	P33.5	I	SLOW / PU1 / VEVRSB / ES5	General-purpose input
	GTM_TIM4_IN5_10			Mux input channel 5 of TIM module 4
	GTM_TIM1_IN1_8			Mux input channel 1 of TIM module 1
	GTM_TIM0_IN1_8			Mux input channel 1 of TIM module 0
	EDSADC_DSCIN0B			Modulator clock input, channel 0
	EDSADC_ITR1F			Trigger/Gate input, channel 1
	GPT120_T4EUDB			Count direction control input of timer T4
	PSI5S_RXC			RX data input
	ASCLIN2_ACTSB			Clear to send input
	CCU61_CCPOS2C			Hall capture input 2
	SENT_SENT5C			Receive input channel 5
	CAN13_RXDB			CAN receive input node 3
	IOM_PIN_5			GPIO pad input to FPC
	EVADC_G10CH2	AI	Analog input channel 2, group 10	
	P33.5	O0	General-purpose output	
	GTM_TOUT27	O1	GTM muxed output	
	IOM_MON0_5		Monitor input 0	
	IOM_GTM_5		GTM-provided inputs to EXOR combiner	
	QSPI0_SLSO7	O2	Master slave select output	
	QSPI1_SLSO7	O3	Master slave select output	
EDSADC_DSCOUT0	O4	Modulator clock output		
EVADC_EMUX11	O5	Control of external analog multiplexer interface 1		
EVADC_FC2BFLOUT	O6	Boundary flag output, FC channel 2		
ASCLIN5_ASLSO	O7	Slave select signal output		

TC37xEXT Pin Definition and Functions LFBGA-292 Package Pinning of

Table 2-34 Port 33 Functions (cont'd)

Ball	Symbol	Ctrl.	Buffer Type	Function	
W13	P33.6	I	SLOW / PU1 / VEVRSB / ES5	General-purpose input	
	GTM_TIM1_IN2_9			Mux input channel 2 of TIM module 1	
	GTM_TIM0_IN2_9			Mux input channel 2 of TIM module 0	
	EDSADC_ITR2F			Trigger/Gate input, channel 2	
	GPT120_T2EUDB			Count direction control input of timer T2	
	SENT_SENT4C			Receive input channel 4	
	CCU61_CCPOS1C			Hall capture input 1	
	EDSADC_DSDIN0B			Digital datastream input, channel 0	
	ASCLIN8_ARXD			Receive input	
	IOM_PIN_6			GPIO pad input to FPC	
	GTM_DTMT2_1			CDTM2_DTM0	
	EVADC_G10CH1			AI	Analog input channel 1, group 10
	P33.6			O0	General-purpose output
	GTM_TOUT28	O1	GTM muxed output		
	IOM_MON0_6		Monitor input 0		
	IOM_GTM_6		GTM-provided inputs to EXOR combiner		
	ASCLIN2_ASLSO	O2	Slave select signal output		
	QSPI2_SLSO11	O3	Master slave select output		
	—	O4	Reserved		
	EVADC_EMUX10	O5	Control of external analog multiplexer interface 1		
EVADC_FC1BFLOUT	O6	Boundary flag output, FC channel 1			
PSI5S_TX	O7	TX data output			

TC37xEXT Pin Definition and Functions LFBGA-292 Package Pinning of

Table 2-34 Port 33 Functions (cont'd)

Ball	Symbol	Ctrl.	Buffer Type	Function
Y13	P33.7	I	SLOW / PU1 / VEVRSB / ES5	General-purpose input
	GTM_TIM1_IN3_9			Mux input channel 3 of TIM module 1
	GTM_TIM0_IN3_9			Mux input channel 3 of TIM module 0
	CAN00_RXDE			CAN receive input node 0
	GPT120_T2INB			Trigger/gate input of timer T2
	CCU61_CCPOS0C			Hall capture input 0
	SCU_E_REQ4_0			ERU Channel 4 inputs 0 to 5 (0 is the LSB and 5 is the MSB)
	SENT_SENT14C			Receive input channel 14
	IOM_PIN_7			GPIO pad input to FPC
	EVADC_G10CH0			Analog input channel 0, group 10
	P33.7	O0	General-purpose output	
	GTM_TOUT29	O1	GTM muxed output	
	IOM_MON0_7	O1	Monitor input 0	
	IOM_GTM_7		GTM-provided inputs to EXOR combiner	
	ASCLIN2_ASCLK	O2	Shift clock output	
	QSPI4_SLSO7	O3	Master slave select output	
	ASCLIN8_ATX	O4	Transmit output	
	—	O5	Reserved	
	EVADC_FC3BFLOUT	O6	Boundary flag output, FC channel 3	
	—	O7	Reserved	

TC37xEXT Pin Definition and Functions LFBGA-292 Package Pinning of

Table 2-34 Port 33 Functions (cont'd)

Ball	Symbol	Ctrl.	Buffer Type	Function
W14	P33.8	I	FAST / HighZ / VEVRSB	General-purpose input
	GTM_TIM1_IN4_7			Mux input channel 4 of TIM module 1
	GTM_TIM0_IN4_7			Mux input channel 4 of TIM module 0
	ASCLIN2_ARXE			Receive input
	SCU_EMGSTOP_POR T_A			Emergency stop Port Pin A input request
	IOM_PIN_8			GPIO pad input to FPC
	P33.8	O0		General-purpose output
	GTM_TOUT30	O1		GTM muxed output
	IOM_MON0_8			Monitor input 0
	ASCLIN2_ATX	O2		Transmit output
	IOM_MON2_14			Monitor input 2
	IOM_REF2_14			Reference input 2
	QSPI4_SLSO2	O3		Master slave select output
	—	O4		Reserved
	CAN00_TXD	O5		CAN transmit output node 0
	IOM_MON2_5			Monitor input 2
	IOM_REF2_5			Reference input 2
	—	O6		Reserved
	CCU61_COUT62	O7		T12 PWM channel 62
	IOM_MON1_13			Monitor input 1
IOM_REF1_8			Reference input 1	
SMU_FSP0	O		FSP[1..0] Output Signals - Generated by SMU_core	

TC37xEXT Pin Definition and Functions LFBGA-292 Package Pinning of

Table 2-34 Port 33 Functions (cont'd)

Ball	Symbol	Ctrl.	Buffer Type	Function
Y14	P33.9	I	SLOW / PU1 / VEVRSB / ES5	General-purpose input
	GTM_TIM1_IN1_9			Mux input channel 1 of TIM module 1
	GTM_TIM0_IN1_9			Mux input channel 1 of TIM module 0
	IOM_PIN_9			GPIO pad input to FPC
	P33.9	O0	SLOW / PU1 / VEVRSB / ES5	General-purpose output
	GTM_TOUT31	O1		GTM muxed output
	IOM_MON0_9	O2		Monitor input 0
	ASCLIN2_ATX			Transmit output
	IOM_MON2_14			Monitor input 2
	IOM_REF2_14	O3		Reference input 2
	QSPI4_SLSO1			Master slave select output
	ASCLIN2_ASCLK	O4		Shift clock output
	CAN01_TXD	O5		CAN transmit output node 1
	IOM_MON2_6			Monitor input 2
	IOM_REF2_6			Reference input 2
	ASCLIN0_ATX	O6		Transmit output
	IOM_MON2_12			Monitor input 2
	IOM_REF2_12			Reference input 2
	CCU61_CC62	O7		T12 PWM channel 62
	IOM_MON1_10			Monitor input 1
IOM_REF1_11	Reference input 1			

TC37xEXT Pin Definition and Functions LFBGA-292 Package Pinning of

Table 2-34 Port 33 Functions (cont'd)

Ball	Symbol	Ctrl.	Buffer Type	Function
W15	P33.10	I	FAST / PU1 / VEVRSB / ES5	General-purpose input
	GTM_TIM4_IN4_14			Mux input channel 4 of TIM module 4
	GTM_TIM1_IN0_9			Mux input channel 0 of TIM module 1
	GTM_TIM0_IN0_9			Mux input channel 0 of TIM module 0
	QSPI4_SLSIA			Slave select input
	CAN01_RXDD			CAN receive input node 1
	ASCLIN0_ARXD			Receive input
	IOM_PIN_10			GPIO pad input to FPC
	P33.10			O0
	GTM_TOUT32	O1	GTM muxed output	
	IOM_MON0_10		Monitor input 0	
	QSPI1_SLSO6	O2	Master slave select output	
	QSPI4_SLSO0	O3	Master slave select output	
	ASCLIN1_ASLSO	O4	Slave select signal output	
	PSI5S_CLK	O5	PSI5S CLK is a clock that can be used on a pin to drive the external PHY.	
	—	O6	Reserved	
	CCU61_COUT61	O7	T12 PWM channel 61	
	IOM_MON1_12		Monitor input 1	
	IOM_REF1_9		Reference input 1	
SMU_FSP1	O	FSP[1..0] Output Signals - Generated by SMU_core		
Y15	P33.11	I	FAST / PU1 / VEVRSB / ES5	General-purpose input
	GTM_TIM1_IN2_8			Mux input channel 2 of TIM module 1
	GTM_TIM0_IN2_8			Mux input channel 2 of TIM module 0
	QSPI4_SCLKA			Slave SPI clock inputs
	IOM_PIN_11			GPIO pad input to FPC
	P33.11	O0	General-purpose output	
	GTM_TOUT33	O1	GTM muxed output	
	IOM_MON0_11		Monitor input 0	
	ASCLIN1_ASCLK	O2	Shift clock output	
	QSPI4_SCLK	O3	Master SPI clock output	
	—	O4	Reserved	
	—	O5	Reserved	
	EDSADC_CGPWMN	O6	Negative carrier generator output	
	CCU61_CC61	O7	T12 PWM channel 61	
	IOM_MON1_9		Monitor input 1	
IOM_REF1_12		Reference input 1		

TC37xEXT Pin Definition and Functions LFBGA-292 Package Pinning of

Table 2-34 Port 33 Functions (cont'd)

Ball	Symbol	Ctrl.	Buffer Type	Function
W16	P33.12	I	FAST / PU1 / VEVRSB / ES5	General-purpose input
	GTM_TIM3_IN0_6			Mux input channel 0 of TIM module 3
	GTM_TIM2_IN0_6			Mux input channel 0 of TIM module 2
	QSPI4_MTSRA			Slave SPI data input
	CAN00_RXDD			CAN receive input node 0
	PMS_PINBWKP			PINB (P33.12) pin input
	IOM_PIN_12			GPIO pad input to FPC
	P33.12	O0	General-purpose output	
	GTM_TOUT34	O1	GTM muxed output	
	IOM_MON0_12	O2	Monitor input 0	
	ASCLIN1_ATX		Transmit output	
	IOM_MON2_13		Monitor input 2	
	IOM_REF2_13	O3	Reference input 2	
	QSPI4_MTSR		Master SPI data output	
	ASCLIN1_ASCLK	O4	Shift clock output	
	CAN22_TXD	O5	CAN transmit output node 2	
	EDSADC_CGPWMP	O6	Positive carrier generator output	
	CCU61_COUT60	O7	T12 PWM channel 60	
	IOM_MON1_11		Monitor input 1	
	IOM_REF1_10		Reference input 1	

TC37xEXT Pin Definition and Functions LFBGA-292 Package Pinning of

Table 2-34 Port 33 Functions (cont'd)

Ball	Symbol	Ctrl.	Buffer Type	Function
Y16	P33.13	I	FAST / PU1 / VEVRSB / ES5	General-purpose input
	GTM_TIM3_IN1_5			Mux input channel 1 of TIM module 3
	GTM_TIM2_IN1_5			Mux input channel 1 of TIM module 2
	ASCLIN1_ARXF			Receive input
	EDSADC_SGNB			Carrier sign signal input
	QSPI4_MRSTA			Master SPI data input
	MSC1_INJ1			Injection signal from port
	CAN22_RXDA			CAN receive input node 2
	P33.13	O0	General-purpose output	
	GTM_TOUT35	O1	GTM muxed output	
	ASCLIN1_ATX	O2	Transmit output	
	IOM_MON2_13		Monitor input 2	
	IOM_REF2_13		Reference input 2	
	QSPI4_MRST	O3	Slave SPI data output	
	IOM_MON2_4		Monitor input 2	
	IOM_REF2_4		Reference input 2	
	QSPI2_SLSO6	O4	Master slave select output	
	CAN00_TXD	O5	CAN transmit output node 0	
	IOM_MON2_5		Monitor input 2	
	IOM_REF2_5		Reference input 2	
	—	O6	Reserved	
	CCU61_CC60	O7	T12 PWM channel 60	
	IOM_MON1_8		Monitor input 1	
	IOM_REF1_13		Reference input 1	

TC37xEXT Pin Definition and Functions LFBGA-292 Package Pinning of

Table 2-34 Port 33 Functions (cont'd)

Ball	Symbol	Ctrl.	Buffer Type	Function	
T14	P33.14	I	FAST / PU1 / VEVRSB / ES5	General-purpose input	
	GTM_TIM5_IN0_8			Mux input channel 0 of TIM module 5	
	GTM_TIM4_IN5_14			Mux input channel 5 of TIM module 4	
	GTM_TIM2_IN0_8			Mux input channel 0 of TIM module 2	
	QSPI2_SCLKD			Slave SPI clock inputs	
	CBS_TGI6			Trigger input	
	P33.14	O0	SLOW / PU1 / VEVRSB / ES5	General-purpose output	
	GTM_TOUT143	O1		GTM muxed output	
	—	O2		Reserved	
	QSPI2_SCLK	O3		Master SPI clock output	
	—	O4		Reserved	
	—	O5		Reserved	
	—	O6		Reserved	
	CCU60_CC62	O7		T12 PWM channel 62	
	IOM_MON1_0	O		Monitor input 1	
	IOM_REF1_4			Reference input 1	
CBS_TGO6	O	Trigger output			
U14	P33.15	I	SLOW / PU1 / VEVRSB / ES5	General-purpose input	
	GTM_TIM5_IN1_9			Mux input channel 1 of TIM module 5	
	GTM_TIM4_IN6_12			Mux input channel 6 of TIM module 4	
	GTM_TIM2_IN1_7			Mux input channel 1 of TIM module 2	
	CBS_TGI7	O0	SLOW / PU1 / VEVRSB / ES5	Trigger input	
	P33.15			General-purpose output	
	GTM_TOUT144			GTM muxed output	
	—			Reserved	
	QSPI2_SLSO11			Master slave select output	
	—			Reserved	
	—			Reserved	
	—			Reserved	
	CCU60_COUT62			O7	T12 PWM channel 62
	IOM_MON1_5			O	Monitor input 1
	IOM_REF1_1	Reference input 1			
	CBS_TGO7	O	Trigger output		

TC37xEXT Pin Definition and Functions LFBGA-292 Package Pinning of

Table 2-35 Port 34 Functions

Ball	Symbol	Ctrl.	Buffer Type	Function
U11	P34.1	I	SLOW / PU1 / VEVR SB / ES5	General-purpose input
	GTM_TIM5_IN3_9			Mux input channel 3 of TIM module 5
	GTM_TIM3_IN4_12			Mux input channel 4 of TIM module 3
	GTM_TIM2_IN3_9			Mux input channel 3 of TIM module 2
	EVADC_G10CH11	AI		Analog input channel 11, group 10
	P34.1	O0		General-purpose output
	GTM_TOUT146	O1		GTM muxed output
	ASCLIN4_ATX	O2		Transmit output
	—	O3		Reserved
	CAN00_TXD	O4		CAN transmit output node 0
	IOM_MON2_5			Monitor input 2
	IOM_REF2_5			Reference input 2
	CAN20_TXD	O5		CAN transmit output node 0
	—	O6		Reserved
	CCU60_COUT63	O7		T13 PWM channel 63
	IOM_MON1_6			Monitor input 1
IOM_REF1_0		Reference input 1		
T12	P34.2	I	SLOW / PU1 / VEVR SB / ES	General-purpose input
	GTM_TIM5_IN4_9			Mux input channel 4 of TIM module 5
	GTM_TIM3_IN5_13			Mux input channel 5 of TIM module 3
	GTM_TIM2_IN4_8			Mux input channel 4 of TIM module 2
	ASCLIN4_ARXB			Receive input
	CAN00_RXDG			CAN receive input node 0
	CAN20_RXDC			CAN receive input node 0
	EVADC_G10CH10	AI		Analog input channel 10, group 10
	P34.2	O0		General-purpose output
	GTM_TOUT147	O1		GTM muxed output
	—	O2		Reserved
	—	O3		Reserved
	—	O4		Reserved
	—	O5		Reserved
	—	O6		Reserved
	CCU60_CC60	O7		T12 PWM channel 60
IOM_MON1_2		Monitor input 1		
IOM_REF1_6		Reference input 1		

TC37xEXT Pin Definition and Functions LFBGA-292 Package Pinning of

Table 2-35 Port 34 Functions (cont'd)

Ball	Symbol	Ctrl.	Buffer Type	Function
U12	P34.3	I	SLOW / PU1 / VEVRSB / ES	General-purpose input
	GTM_TIM5_IN5_10			Mux input channel 5 of TIM module 5
	GTM_TIM3_IN6_13			Mux input channel 6 of TIM module 3
	GTM_TIM2_IN5_9			Mux input channel 5 of TIM module 2
	EVADC_G10CH9	AI		Analog input channel 9, group 10
	P34.3	O0		General-purpose output
	GTM_TOUT148	O1		GTM muxed output
	ASCLIN4_ASCLK	O2		Shift clock output
	—	O3		Reserved
	QSPI2_SLSO10	O4		Master slave select output
	—	O5		Reserved
	—	O6		Reserved
	CCU60_COUT60	O7		T12 PWM channel 60
	IOM_MON1_3			Monitor input 1
IOM_REF1_3	Reference input 1			
T13	P34.4	I	SLOW / PU1 / VEVRSB / ES	General-purpose input
	GTM_TIM5_IN6_10			Mux input channel 6 of TIM module 5
	GTM_TIM3_IN7_12			Mux input channel 7 of TIM module 3
	GTM_TIM2_IN6_8			Mux input channel 6 of TIM module 2
	QSPI2_MRSTD			Master SPI data input
	EVADC_G10CH8	AI		Analog input channel 8, group 10
	P34.4	O0		General-purpose output
	GTM_TOUT149	O1		GTM muxed output
	ASCLIN4_ASLSO	O2		Slave select signal output
	—	O3		Reserved
	QSPI2_MRST	O4		Slave SPI data output
	IOM_MON2_2			Monitor input 2
	IOM_REF2_2			Reference input 2
	—	O5		Reserved
	—	O6		Reserved
	CCU60_CC61	O7		T12 PWM channel 61
	IOM_MON1_1			Monitor input 1
IOM_REF1_5	Reference input 1			

TC37xEXT Pin Definition and Functions LFBGA-292 Package Pinning of

Table 2-35 Port 34 Functions (cont'd)

Ball	Symbol	Ctrl.	Buffer Type	Function
U13	P34.5	I	FAST / PU1 / VEVR SB / ES	General-purpose input
	GTM_TIM5_IN7_9			Mux input channel 7 of TIM module 5
	GTM_TIM4_IN7_12			Mux input channel 7 of TIM module 4
	GTM_TIM2_IN7_9			Mux input channel 7 of TIM module 2
	QSPI2_MTSRD			Slave SPI data input
	ASCLIN8_ARXE			Receive input
	P34.5	O0		General-purpose output
	GTM_TOUT150	O1		GTM muxed output
	ASCLIN8_ATX	O2		Transmit output
	—	O3		Reserved
	QSPI2_MTSR	O4		Master SPI data output
	—	O5		Reserved
	—	O6		Reserved
	CCU60_COUT61	O7		T12 PWM channel 61
	IOM_MON1_4			Monitor input 1
IOM_REF1_2		Reference input 1		

Table 2-36 Analog Inputs

Ball	Symbol	Ctrl.	Buffer Type	Function
T10	AN0	I	D / HighZ / VDDM	Analog Input 0
	EVADC_G0CH0			Analog input channel 0, group 0
	EDSADC_EDS3PA			Positive analog input channel 3, pin A
U10	AN1	I	D / HighZ / VDDM	Analog Input 1
	EVADC_G0CH1			Analog input channel 1, group 0
	EDSADC_EDS3NA			Negative analog input channel 3, pin A
W9	AN2	I	D / HighZ / VDDM	Analog Input 2
	EVADC_G0CH2			Analog input channel 2, group 0
	EDSADC_EDS0PA			Positive analog input channel 0, pin A
U9	AN3	I	D / HighZ / VDDM	Analog Input 3
	EVADC_G0CH3			Analog input channel 3, group 0
	EDSADC_EDS0NA			Negative analog input channel 0, pin A
T9	AN4	I	D / HighZ / VDDM	Analog Input 4
	EVADC_G11CH0			Analog input channel 0, group 11
	EVADC_G0CH4			Analog input channel 4, group 0
Y9	AN5	I	D / HighZ / VDDM	Analog Input 5
	EVADC_G11CH1			Analog input channel 1, group 11
	EVADC_G0CH5			Analog input channel 5, group 0

TC37xEXT Pin Definition and Functions LFBGA-292 Package Pinning of

Table 2-36 Analog Inputs (cont'd)

Ball	Symbol	Ctrl.	Buffer Type	Function
T8	AN6	I	D / HighZ / VDDM	Analog Input 6
	EVADC_G11CH2			Analog input channel 2, group 11
	EVADC_G0CH6			Analog input channel 6, group 0
U8	AN7	I	D / HighZ / VDDM	Analog Input 7
	EVADC_G11CH3			Analog input channel 3, group 11
	EVADC_G0CH7			Analog input channel 7, group 0
W8	AN8	I	D / HighZ / VDDM	Analog Input 8
	EVADC_G11CH4			Analog input channel 4, group 11
	EVADC_G1CH0			Analog input channel 0, group 1
U7	AN9	I	D / HighZ / VDDM	Analog Input 9
	EVADC_G11CH5			Analog input channel 5, group 11
	EVADC_G1CH1			Analog input channel 1, group 1
Y8	AN10	I	D / HighZ / VDDM	Analog Input 10
	EVADC_G11CH6			Analog input channel 6, group 11
	EVADC_G1CH2			Analog input channel 2, group 1
W7	AN11	I	D / HighZ / VDDM	Analog Input 11
	EVADC_G11CH7			Analog input channel 7, group 11
	EVADC_G1CH3			Analog input channel 3, group 1
T7	AN12	I	D / HighZ / VDDM	Analog Input 12
	EVADC_G1CH4			Analog input channel 4, group 1
	EDSADC_EDS0PB			Positive analog input channel 0, pin B
W6	AN13	I	D / HighZ / VDDM	Analog Input 13
	EVADC_G1CH5			Analog input channel 5, group 1
	EDSADC_EDS0NB			Negative analog input channel 0, pin B
U6	AN14	I	D / HighZ / VDDM	Analog Input 14
	EVADC_G1CH6			Analog input channel 6, group 1
	EDSADC_EDS3PB			Positive analog input channel 3, pin B
T6	AN15	I	D / HighZ / VDDM	Analog Input 15
	EVADC_G1CH7			Analog input channel 7, group 1
	EDSADC_EDS3NB			Negative analog input channel 3, pin N
W5	AN16	I	D / HighZ / VDDM	Analog Input 16
	EVADC_G2CH0			Analog input channel 0, group 2
	EVADC_FC0CH0			Analog input FC channel 0
U5	AN17/P40.10	I	S / HighZ / VDDM	Analog Input 17
	SENT_SENT10A			Receive input channel 10
	EVADC_G2CH1			Analog input channel 1, group 2
	EVADC_FC1CH0			Analog input FC channel 1

TC37xEXT Pin Definition and Functions LFBGA-292 Package Pinning of

Table 2-36 Analog Inputs (cont'd)

Ball	Symbol	Ctrl.	Buffer Type	Function
W4	AN18/P40.11	I	S / HighZ / VDDM	Analog Input 18
	SENT_SENT11A			Receive input channel 11
	EVADC_G11CH8			Analog input channel 8, group 11
	EVADC_G2CH2			Analog input channel 2, group 2
W3	AN19/P40.12	I	S / HighZ / VDDM	Analog Input 19
	SENT_SENT12A			Receive input channel 12
	EVADC_G11CH9			Analog input channel 9, group 11
	EVADC_G2CH3			Analog input channel 3, group 2
Y3	AN20	I	D / HighZ / VDDM	Analog Input 20
	EVADC_G2CH4			Analog input channel 4, group 2
	EDSADC_EDS2PA			Positive analog input channel 2, pin A
Y2	AN21	I	D / HighZ / VDDM	Analog Input 21
	EVADC_G2CH5			Analog input channel 5, group 2
	EDSADC_EDS2NA			Negative analog input channel 2, pin A
T5	AN22	I	D / HighZ / VDDM	Analog Input 22
	EVADC_G2CH6			Analog input channel 6, group 2
R5	AN23	I	D / HighZ / VDDM	Analog Input 23
	EVADC_G2CH7			Analog input channel 7, group 2
W2	AN24/P40.0	I	S / HighZ / VDDM	Analog Input 24
	SENT_SENT0A			Receive input channel 0
	EVADC_G3CH0			Analog input channel 0, group 3
	CCU60_CCPOS0D			Hall capture input 0
	EDSADC_EDS2PB			Positive analog input channel 2, pin B
W1	AN25/P40.1	I	S / HighZ / VDDM	Analog Input 25
	SENT_SENT1A			Receive input channel 1
	EVADC_G3CH1			Analog input channel 1, group 3
	CCU60_CCPOS1B			Hall capture input 1
	EDSADC_EDS2NB			Negative analog input channel 2, pin B
V2	AN26/P40.2	I	S / HighZ / VDDM	Analog Input 26
	SENT_SENT2A			Receive input channel 2
	EVADC_G3CH2			Analog input channel 2, group 3
	CCU60_CCPOS1D			Hall capture input 1
	EVADC_G11CH10			Analog input channel 10, group 11
V1	AN27/P40.3	I	S / HighZ / VDDM	Analog Input 27
	SENT_SENT3A			Receive input channel 3
	EVADC_G3CH3			Analog input channel 3, group 3
	CCU60_CCPOS2B			Hall capture input 2
	EVADC_G11CH11			Analog input channel 11, group 11

TC37xEXT Pin Definition and Functions LFBGA-292 Package Pinning of

Table 2-36 Analog Inputs (cont'd)

Ball	Symbol	Ctrl.	Buffer Type	Function
U2	AN28/P40.13	I	S / HighZ / VDDM	Analog Input 28
	SENT_SENT13A			Receive input channel 13
	EVADC_G3CH4			Analog input channel 4, group 3
U1	AN29/P40.14	I	S / HighZ / VDDM	Analog Input 29
	SENT_SENT14A			Receive input channel 14
	EVADC_G3CH5			Analog input channel 5, group 3
T4	AN30	I	D / HighZ / VDDM	Analog Input 30
	EVADC_G3CH6			Analog input channel 6, group 3
R4	AN31	I	D / HighZ / VDDM	Analog Input 31
	EVADC_G3CH7			Analog input channel 7, group 3
P4	AN32/P40.4	I	S / HighZ / VDDM	Analog Input 32
	SENT_SENT4A			Receive input channel 4
	EVADC_G8CH0			Analog input channel 0, group 8
	CCU60_CCPOS2D			Hall capture input 2
	EVADC_G11CH12			Analog input channel 12, group 11
R1	AN33/P40.5	I	S / HighZ / VDDM	Analog Input 33
	SENT_SENT5A			Receive input channel 5
	EVADC_G8CH1			Analog input channel 1, group 8
	CCU61_CCPOS0D			Hall capture input 0
	EVADC_G11CH13			Analog input channel 13, group 11
P5	AN34	I	D / HighZ / VDDM	Analog Input 34
	EVADC_G8CH2			Analog input channel 2, group 8
	EVADC_G11CH14			Analog input channel 14, group 11
R2	AN35	I	D / HighZ / VDDM	Analog Input 35
	EVADC_G8CH3			Analog input channel 3, group 8
	EVADC_G11CH15			Analog input channel 15, group 11
N4	AN36/P40.6	I	S / HighZ / VDDM	Analog Input 36
	SENT_SENT6A			Receive input channel 6
	EVADC_G8CH4			Analog input channel 4, group 8
	CCU61_CCPOS1B			Hall capture input 1
	EDSADC_EDS1PA			Positive analog input channel 1, pin A
P2	AN37/P40.7	I	S / HighZ / VDDM	Analog Input 37
	SENT_SENT7A			Receive input channel 7
	EVADC_G8CH5			Analog input channel 5, group 8
	CCU61_CCPOS1D			Hall capture input 1
	EDSADC_EDS1NA			Negative analog input channel 1, pin A

TC37xEXT Pin Definition and Functions LFBGA-292 Package Pinning of

Table 2-36 Analog Inputs (cont'd)

Ball	Symbol	Ctrl.	Buffer Type	Function
N5	AN38/P40.8	I	S / HighZ / VDDM	Analog Input 38
	SENT_SENT8A			Receive input channel 8
	EVADC_G8CH6			Analog input channel 6, group 8
	CCU61_CCPOS2B			Hall capture input 2
	EDSADC_EDS1PB			Positive analog input channel 1, pin B
P1	AN39/P40.9	I	S / HighZ / VDDM	Analog Input 39
	SENT_SENT9A			Receive input channel 9
	EVADC_G8CH7			Analog input channel 7, group 8
	CCU61_CCPOS2D			Hall capture input 2
	EDSADC_EDS1NB			Negative analog input channel 1, pin B
M5	AN40	I	D / HighZ / VDDM	Analog Input 40
	EVADC_G8CH8			Analog input channel 8, group 8
M4	AN41	I	D / HighZ / VDDM	Analog Input 41
	EVADC_G8CH9			Analog input channel 9, group 8
L5	AN42	I	D / HighZ / VDDM	Analog Input 42
	EVADC_G8CH10			Analog input channel 10, group 8
L4	AN43	I	D / HighZ / VDDM	Analog Input 43
	EVADC_G8CH11			Analog input channel 11, group 8
N1	AN44	I	D / HighZ / VDDM	Analog Input 44
	EVADC_G8CH12			Analog input channel 12, group 8
	EDSADC_EDS1PC			Positive analog input channel 1, pin C
N2	AN45	I	D / HighZ / VDDM	Analog Input 45
	EVADC_G8CH13			Analog input channel 13, group 8
	EDSADC_EDS1NC			Negative analog input channel 1, pin C
M1	AN46	I	D / HighZ / VDDM	Analog Input 46
	EVADC_G8CH14			Analog input channel 14, group 8
	EDSADC_EDS1PD			Positive analog input channel 1, pin D
M2	AN47	I	D / HighZ / VDDM	Analog Input 47
	EVADC_G8CH15			Analog input channel 15, group 8
	EDSADC_EDS1ND			Negative analog input channel 1, pin D

TC37xEXT Pin Definition and Functions LFBGA-292 Package Pinning of

Table 2-37 System I/O

Ball	Symbol	Ctrl.	Buffer Type	Function
L7	AGBTCLKN (VSS)	I	AGBT_C LK / VEXT	Input PAD (negative pole) for the external 100 MHz differential clock. AGBT Input; (TC3xx devices without AGBT: VSS)
K7	AGBTCLKP (VSS)	I	AGBT_C LK / VEXT	Input PAD (positive pole) for the external 100 MHz differential clock. AGBT Input; (TC3xx devices without AGBT: VSS)
P10	AGBTTXN (VSS)	O	AGBT_T X / VEXT	Off-chip driver output PAD of the 2.5Gbps transmitter, negative pole AGBT Output; (TC3xx devices without AGBT: VSS)
P11	AGBTTXP (VSS)	O	AGBT_T X / VEXT	Off-chip driver output PAD of the 2.5Gbps transmitter, positive pole AGBT Output; (TC3xx devices without AGBT: VSS)
L14	AGBTERR (VSS)	I	FAST / PD / VEXT	Input PAD for CRC error from FPGA. AGBT Input; (TC3xx devices without AGBT: VSS)
Y17	VGATE1N	O	—	DCDC N ch. MOSFET gate driver output P32.0 / SMPS mode: analog output. External Pass Device gate control for EVRC
W17	VGATE1P	O	—	DCDC P ch. MOSFET gate driver output P32.1 / External Pass Device gate control for EVRC
M20	XTAL1	I	XTAL / VEXT	XTAL pad1 XTAL1. Main Oscillator/PLL/Clock Generator Input.
M19	XTAL2	O	XTAL / VEXT	XTAL pad2 XTAL2. Main Oscillator/PLL/Clock Generator OUTPUT
G10	DAPE2	I/O	FAST / PD2 / VEXT	DAPE: DAPE2 Data I/O DAPE: DAPE2 Data I/O (TC3xx devices without DAPE: VSS)
G11	DAPE1	I/O	FAST / PD2 / VEXT	DAPE: DAPE1 Data I/O DAPE: DAPE1 Data I/O (TC3xx devices without DAPE: VSS)
K16	TMS	I	FAST / PD2 / VEXT	JTAG Module State Machine Control Input TMS: JTAG Module State Machine Control Input. DAP: DAP1 Data I/O.
	DAP1	I/O		DAP: DAP1 Data I/O
K14	DAPE0	I	FAST / PD2 / VEXT	DAPE: DAPE0 Clock Input DAPE: DAPE0 clock input (TC3xx devices without DAPE: NC)
L19	$\overline{\text{TRST}}$	I	FAST / PU2 / VEXT	JTAG Module Reset/Enable Input TRST_N: JTAG Module Reset/Enable Input. DAPE: DAPE0 Clock Input
	DAPE0	I		DAPE: DAPE0 Clock Input

TC37xEXT Pin Definition and Functions LFBGA-292 Package Pinning of

Table 2-37 System I/O (cont'd)

Ball	Symbol	Ctrl.	Buffer Type	Function
J16	TCK	I	FAST / PD2 / VEXT	JTAG Module Clock Input TCK: JTAG Module Clock Input. DAP: DAP0 Clock Input.
	DAP0	I	VEXT	DAP: DAP0 Clock Input
G16	$\overline{\text{ESR1}}$	I	FAST / PU1 / VEXT	ESR1 Port Pin input - can be used to trigger a reset or an NMI ESR1: External System Request Reset 1. Default NMI function. See also SCU chapter for details. Default after power-on can be different. See also SCU chapter 'Reset Control Unit' and SCU_IOCR register description. PMS_EVRWUP: EVR Wakeup Pin
	PMS_ESR1WKP	I		ESR1 pin input
G17	$\overline{\text{PORST}}$	I/O	PORST / PD / VEXT	PORST pin Power On Reset Input. Additional strong PD in case of power fail.
F16	$\overline{\text{ESR0}}$	I	FAST / OD / VEXT	ESR0 Port Pin input - can be used to trigger a reset or an NMI ESR0: External System Request Reset 0. Default configuration during and after reset is open-drain driver. The driver drives low during power-on reset. This is valid additionally after deactivation of PORST_N until the internal reset phase has finished. See also SCU chapter for details. Default after power-on can be different. See also SCU chapter 'Reset Control Unit' and SCU_IOCR register description. PMS_EVRWUP: EVR Wakeup Pin
	PMS_ESR0WKP	I		ESR0 pin input

Table 2-38 Supply

Ball	Symbol	Ctrl.	Buffer Type	Function
P8, P13, N7, N14, E15, H14, D16, G13	VDD	I	—	Digital Core Power Supply (1.25V)
A2, B3, W20	VEXT	I	—	External Power Supply (5V / 3.3V)
D5	VFLEX	I	—	Digital Power Supply for Flex Port Pads (5V / 3.3V)
V19	VFLEX2	I	—	Digital Power Supply for Flex Port Pads (5V / 3.3V)
Y5	VDDM	I	—	ADC Analog Power Supply (5V / 3.3V)
B18, A19	VDDP3	I	—	Flash Power Supply (3.3V)
B2, D4, E5, T16, U17, W19, Y20, E16, D17, B19, A20	VSS	I	—	Digital Ground

TC37xEXT Pin Definition and Functions LFBGA-292 Package Pinning of

Table 2-38 Supply (cont'd)

Ball	Symbol	Ctrl.	Buffer Type	Function
Y4	VSSM	I	—	Analog Ground for VDDM
P9, P12, N9, N10, N11, N12, M7, M8, M10, M11, M13, M14, L8, L9, L10, L11, L12, L13, K8, K9, K10, K11, K12, K13, J7, J8, J10, J11, J13, J14, H9, H10, H11, H12, G9, G12	VSS	I	—	Digital Ground
L20	VSS	I	—	Oscillator Ground, VSS(OSC)
Y6	VAREF1	I	—	Positive Analog Reference Voltage 1
Y7	VAGND1	I	—	Negative Analog Reference Voltage 1
T1	VAREF2	I	—	Positive Analog Reference Voltage 2
T2	VAGND2	I	—	Negative Analog Reference Voltage 2
A1, Y1, U4	NC1	I	—	Not connected. These pins are not connected on package level and will not be used for future extensions
G8, H7	VDDSB (VDD)	I	—	Devices with integrated EMEM: EMEM SRAM Standby Power Supply, VDDSB (1.25V); Devices without integrated EMEM: VDD (1.25V)
T11	VEVRSB	I	—	Standby Power Supply (5V / 3.3V) for the Standby SRAM
N19	VDD	I	—	Digital Power Supply for Oscillator (1.25V), VDD(OSC)
N20	VEXT	I	—	Digital Power Supply for Oscillator (shall be supplied with same level as used for VEXT), VEXT(OSC)

TC37xEXT Pin Definition and Functions LQFP-176 Package Pinning of

2.3 LQFP-176 Package Pinning of TC37xEXT

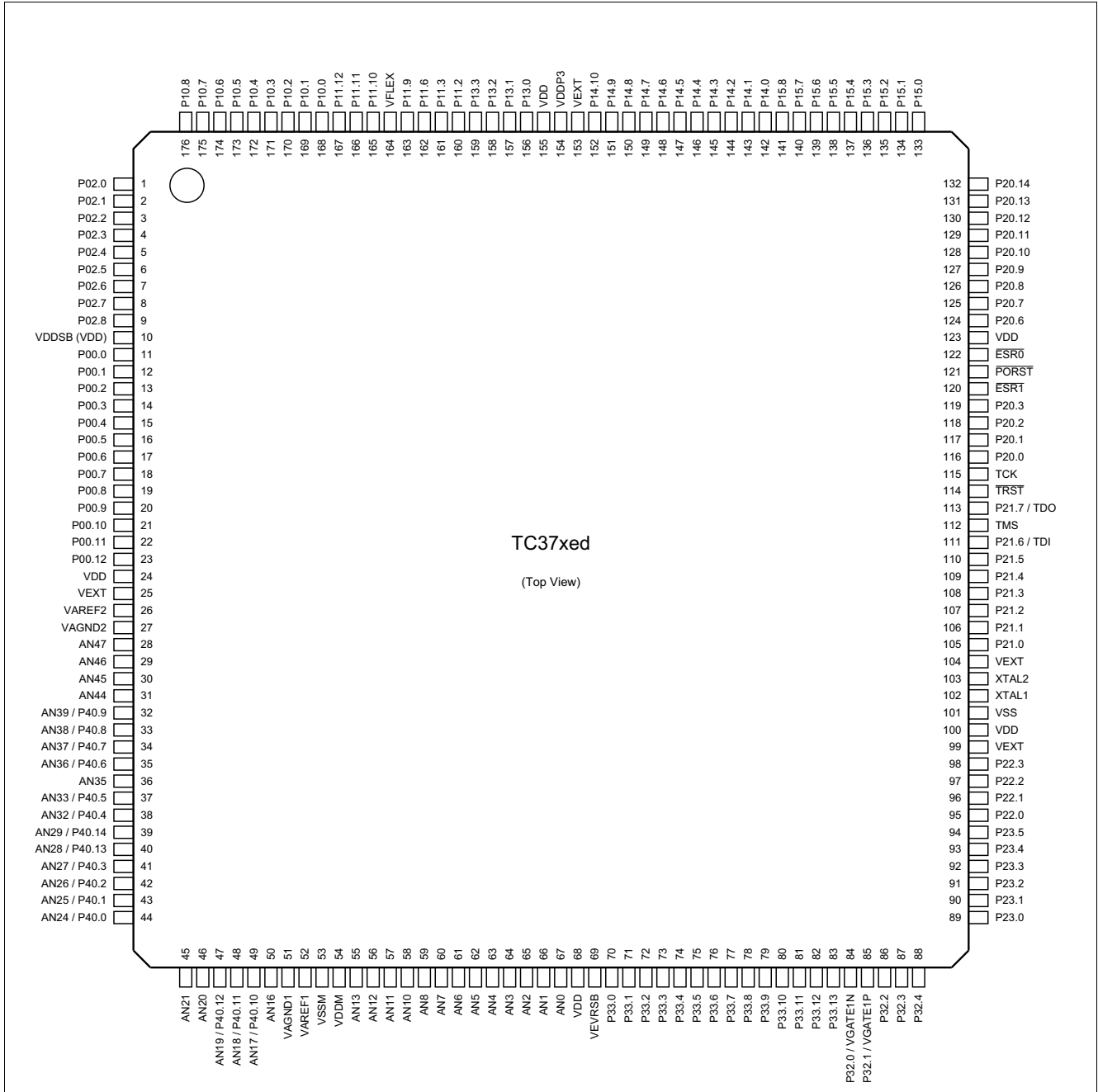

Figure 2-3 TC37xEXT package variant LQFP-176

TC37xEXT Pin Definition and Functions LQFP-176 Package Pinning of

Table 2-39 Port 00 Functions

Pin	Symbol	Ctrl.	Buffer Type	Function
11	P00.0	I	FAST / PU1 / VEXT / ES	General-purpose input
	GTM_TIM5_IN4_10			Mux input channel 4 of TIM module 5
	GTM_TIM3_IN0_1			Mux input channel 0 of TIM module 3
	GTM_TIM2_IN0_1			Mux input channel 0 of TIM module 2
	CCU61_CTRAPA			Trap input capture
	CCU60_T12HRE			External timer start 12
	MSC0_INJ0			Injection signal from port
	CIF_D9			sensor pixel data input
	GETH_MDIOA			MDIO Input
	P00.0			O0
	GTM_TOUT9	O1	GTM muxed output	
	IOM_REF0_9		Reference input 0	
	ASCLIN3_ASCLK	O2	Shift clock output	
	ASCLIN3_ATX	O3	Transmit output	
	IOM_MON2_15		Monitor input 2	
	IOM_REF2_15		Reference input 2	
	—	O4	Reserved	
	CAN10_TXD	O5	CAN transmit output node 0	
	—	O6	Reserved	
	CCU60_COUT63	O7	T13 PWM channel 63	
	IOM_MON1_6		Monitor input 1	
	IOM_REF1_0		Reference input 1	
GETH_MDIO	O	MDIO Output		

TC37xEXT Pin Definition and Functions LQFP-176 Package Pinning of

Table 2-39 Port 00 Functions (cont'd)

Pin	Symbol	Ctrl.	Buffer Type	Function
12	P00.1	I	SLOW / PU1 / VEXT / ES	General-purpose input
	GTM_TIM5_IN5_11			Mux input channel 5 of TIM module 5
	GTM_TIM3_IN1_1			Mux input channel 1 of TIM module 3
	GTM_TIM2_IN1_1			Mux input channel 1 of TIM module 2
	CCU60_CC60INB			T12 capture input 60
	ASCLIN3_ARXE			Receive input
	EDSADC_DSCIN5A			Modulator clock input, channel 5
	CAN10_RXDA			CAN receive input node 0
	PSI5_RX0A			RXD inputs (receive data) channel 0
	CIF_D10			sensor pixel data input
	CCU61_CC60INA			T12 capture input 60
	SENT_SENT0B			Receive input channel 0
	EVADC_G9CH11			AI
	EDSADC_EDS5NA		Negative analog input channel 5, pin A	
	P00.1	O0	General-purpose output	
	GTM_TOUT10	O1	GTM muxed output	
	IOM_REF0_10		Reference input 0	
	ASCLIN3_ATX	O2	Transmit output	
	IOM_MON2_15		Monitor input 2	
	IOM_REF2_15		Reference input 2	
	—	O3	Reserved	
	EDSADC_DSCOUT5	O4	Modulator clock output	
	—	O5	Reserved	
	SENT_SPC0	O6	Transmit output	
	CCU61_CC60	O7	T12 PWM channel 60	
	IOM_MON1_8		Monitor input 1	
IOM_REF1_13		Reference input 1		

TC37xEXT Pin Definition and Functions LQFP-176 Package Pinning of

Table 2-39 Port 00 Functions (cont'd)

Pin	Symbol	Ctrl.	Buffer Type	Function
13	P00.2	I	SLOW / PU1 / VEXT / ES1	General-purpose input
	GTM_TIM5_IN6_11			Mux input channel 6 of TIM module 5
	GTM_TIM3_IN1_2			Mux input channel 1 of TIM module 3
	GTM_TIM2_IN1_2			Mux input channel 1 of TIM module 2
	EDSADC_DSDIN5A			Digital datastream input, channel 5
	SENT_SENT1B			Receive input channel 1
	CIF_D11			sensor pixel data input
	EVADC_G9CH10	AI	Analog input channel 10, group 9	
	EDSADC_EDS5PA		Positive analog input channel 5, pin A	
	P00.2	O0	General-purpose output	
	GTM_TOUT11	O1	GTM muxed output	
	IOM_REF0_11		Reference input 0	
	ASCLIN3_ASCLK	O2	Shift clock output	
	CAN21_TXD	O3	CAN transmit output node 1	
	PSI5_TX0	O4	TXD outputs (send data)	
	IOM_MON1_14		Monitor input 1	
	IOM_REF1_14		Reference input 1	
	CAN03_TXD		O5	CAN transmit output node 3
	IOM_MON2_8		Monitor input 2	
	IOM_REF2_8		Reference input 2	
	QSPI3_SLSO4	O6	Master slave select output	
	CCU61_COUT60	O7	T12 PWM channel 60	
	IOM_MON1_11		Monitor input 1	
IOM_REF1_10	Reference input 1			

TC37xEXT Pin Definition and Functions LQFP-176 Package Pinning of

Table 2-39 Port 00 Functions (cont'd)

Pin	Symbol	Ctrl.	Buffer Type	Function
14	P00.3	I	SLOW / PU1 / VEXT / ES1	General-purpose input
	GTM_TIM5_IN7_10			Mux input channel 7 of TIM module 5
	GTM_TIM3_IN2_1			Mux input channel 2 of TIM module 3
	GTM_TIM2_IN2_1			Mux input channel 2 of TIM module 2
	CCU60_CC61INB			T12 capture input 61
	EDSADC_DSCIN3A			Modulator clock input, channel 3
	EDSADC_ITR5F			Trigger/Gate input, channel 5
	PSI5_RX1A			RXD inputs (receive data) channel 1
	CAN03_RXDA			CAN receive input node 3
	CAN21_RXDA			CAN receive input node 1
	PSI5S_RXA			RX data input
	SENT_SENT2B			Receive input channel 2
	CIF_D12			sensor pixel data input
	CCU61_CC61INA			T12 capture input 61
	EVADC_G9CH9			AI
	EDSADC_EDS5NB		Negative analog input channel 5, pin B	
	P00.3	O0	General-purpose output	
	GTM_TOUT12	O1	GTM muxed output	
	IOM_REF0_12		Reference input 0	
	ASCLIN3_ASLSO	O2	Slave select signal output	
	—	O3	Reserved	
	EDSADC_DSCOUT3	O4	Modulator clock output	
	—	O5	Reserved	
SENT_SPC2	O6	Transmit output		
CCU61_CC61	O7	T12 PWM channel 61		
IOM_MON1_9		Monitor input 1		
IOM_REF1_12		Reference input 1		

TC37xEXT Pin Definition and Functions LQFP-176 Package Pinning of

Table 2-39 Port 00 Functions (cont'd)

Pin	Symbol	Ctrl.	Buffer Type	Function	
15	P00.4	I	SLOW / PU1 / VEXT / ES1	General-purpose input	
	GTM_TIM3_IN3_1			Mux input channel 3 of TIM module 3	
	GTM_TIM2_IN3_1			Mux input channel 3 of TIM module 2	
	SCU_E_REQ2_2			ERU Channel 2 inputs 0 to 5 (0 is the LSB and 5 is the MSB)	
	SENT_SENT3B			Receive input channel 3	
	EDSADC_DSDIN3A			Digital datastream input, channel 3	
	EDSADC_SGNA			Carrier sign signal input	
	ASCLIN10_ARXA			Receive input	
	CIF_D13			sensor pixel data input	
	EVADC_G9CH8			AI	Analog input channel 8, group 9
	EDSADC_EDS5PB				Positive analog input channel 5, pin B
	P00.4			O0	General-purpose output
	GTM_TOUT13			O1	GTM muxed output
	IOM_REF0_13		Reference input 0		
	PSI5S_TX	O2	TX data output		
	CAN11_TXD	O3	CAN transmit output node 1		
	PSI5_TX1	O4	TXD outputs (send data)		
	IOM_MON1_15		Monitor input 1		
	—	O5	Reserved		
	SENT_SPC3	O6	Transmit output		
	CCU61_COUT61	O7	T12 PWM channel 61		
	IOM_MON1_12		Monitor input 1		
	IOM_REF1_9		Reference input 1		

TC37xEXT Pin Definition and Functions LQFP-176 Package Pinning of

Table 2-39 Port 00 Functions (cont'd)

Pin	Symbol	Ctrl.	Buffer Type	Function
16	P00.5	I	SLOW / PU1 / VEXT / ES1	General-purpose input
	GTM_TIM3_IN4_1			Mux input channel 4 of TIM module 3
	GTM_TIM3_IN0_11			Mux input channel 0 of TIM module 3
	GTM_TIM2_IN4_1			Mux input channel 4 of TIM module 2
	CCU60_CC62INB			T12 capture input 62
	EDSADC_DSCIN2A			Modulator clock input, channel 2
	CCU61_CC62INA			T12 capture input 62
	SENT_SENT4B			Receive input channel 4
	CIF_D14			sensor pixel data input
	CAN11_RXDB			CAN receive input node 1
	GTM_DTMT1_1			CDTM1_DTM0
	EVADC_G9CH7			AI
	P00.5	O0	General-purpose output	
	GTM_TOUT14	O1	GTM muxed output	
	IOM_REF0_14		Reference input 0	
	EDSADC_CGPWMN	O2	Negative carrier generator output	
	QSPI3_SLSO3	O3	Master slave select output	
	EDSADC_DSCOUT2	O4	Modulator clock output	
	EVADC_FC0BFLOUT	O5	Boundary flag output, FC channel 0	
	SENT_SPC4	O6	Transmit output	
CCU61_CC62	O7	T12 PWM channel 62		
IOM_MON1_10		Monitor input 1		
IOM_REF1_11		Reference input 1		

TC37xEXT Pin Definition and Functions LQFP-176 Package Pinning of

Table 2-39 Port 00 Functions (cont'd)

Pin	Symbol	Ctrl.	Buffer Type	Function
17	P00.6	I	SLOW / PU1 / VEXT / ES1	General-purpose input
	GTM_TIM3_IN5_1			Mux input channel 5 of TIM module 3
	GTM_TIM3_IN1_14			Mux input channel 1 of TIM module 3
	GTM_TIM2_IN5_1			Mux input channel 5 of TIM module 2
	EDSADC_ITR4F			Trigger/Gate input, channel 4
	EDSADC_DSDIN2A			Digital datastream input, channel 2
	SENT_SENT5B			Receive input channel 5
	CIF_D15			sensor pixel data input
	ASCLIN5_ARXA			Receive input
	EVADC_G9CH6			AI
	P00.6	O0	General-purpose output	
	GTM_TOUT15	O1	GTM muxed output	
	IOM_REF0_15		Reference input 0	
	EDSADC_CGPWMP	O2	Positive carrier generator output	
	—	O3	Reserved	
	—	O4	Reserved	
	EVADC_EMUX10	O5	Control of external analog multiplexer interface 1	
	SENT_SPC5	O6	Transmit output	
	CCU61_COUT62	O7	T12 PWM channel 62	
	IOM_MON1_13		Monitor input 1	
IOM_REF1_8		Reference input 1		

TC37xEXT Pin Definition and Functions LQFP-176 Package Pinning of

Table 2-39 Port 00 Functions (cont'd)

Pin	Symbol	Ctrl.	Buffer Type	Function
18	P00.7	I	SLOW / PU1 / VEXT / ES1	General-purpose input
	GTM_TIM3_IN6_1			Mux input channel 6 of TIM module 3
	GTM_TIM3_IN2_11			Mux input channel 2 of TIM module 3
	GTM_TIM2_IN6_1			Mux input channel 6 of TIM module 2
	CCU61_CC60INC			T12 capture input 60
	SENT_SENT6B			Receive input channel 6
	EDSADC_DSCIN4A			Modulator clock input, channel 4
	GPT120_T2INA			Trigger/gate input of timer T2
	CCU61_CCPOS0A			Hall capture input 0
	CCU60_T12HRB			External timer start 12
	CIF_PCLK			Sensor Pixel Clock input
	GTM_DTMT0_2			CDTM0_DTM0
	EVADC_G9CH5			AI
	EDSADC_EDS4NA	Negative analog input channel 4, pin A		
	P00.7	O0	General-purpose output	
	GTM_TOUT16	O1	GTM muxed output	
	ASCLIN5_ATX	O2	Transmit output	
	EVADC_FC2BFLOUT	O3	Boundary flag output, FC channel 2	
	EDSADC_DSCOUT4	O4	Modulator clock output	
	EVADC_EMUX11	O5	Control of external analog multiplexer interface 1	
	SENT_SPC6	O6	Transmit output	
	CCU61_CC60	O7	T12 PWM channel 60	
	IOM_MON1_8	Monitor input 1		
IOM_REF1_13	Reference input 1			

TC37xEXT Pin Definition and Functions LQFP-176 Package Pinning of

Table 2-39 Port 00 Functions (cont'd)

Pin	Symbol	Ctrl.	Buffer Type	Function
19	P00.8	I	SLOW / PU1 / VEXT / ES1	General-purpose input
	GTM_TIM3_IN7_1			Mux input channel 7 of TIM module 3
	GTM_TIM3_IN3_11			Mux input channel 3 of TIM module 3
	GTM_TIM2_IN7_1			Mux input channel 7 of TIM module 2
	CCU61_CC61INC			T12 capture input 61
	SENT_SENT7B			Receive input channel 7
	EDSADC_DSDIN4A			Digital datastream input, channel 4
	GPT120_T2EUDA			Count direction control input of timer T2
	CCU61_CCPOS1A			Hall capture input 1
	CIF_VSYNC			vertical synchronization signal input
	CCU60_T13HRB			External timer start 13
	ASCLIN10_ARXB			Receive input
	EVADC_G9CH4			AI
	EDSADC_EDS4PA	Positive analog input channel 4, pin A		
	P00.8	O0	General-purpose output	
	GTM_TOUT17	O1	GTM muxed output	
	QSPI3_SLSO6	O2	Master slave select output	
	ASCLIN10_ATX	O3	Transmit output	
	—	O4	Reserved	
	EVADC_EMUX12	O5	Control of external analog multiplexer interface 1	
	SENT_SPC7	O6	Transmit output	
	CCU61_CC61	O7	T12 PWM channel 61	
	IOM_MON1_9		Monitor input 1	
IOM_REF1_12	Reference input 1			

TC37xEXT Pin Definition and Functions LQFP-176 Package Pinning of

Table 2-39 Port 00 Functions (cont'd)

Pin	Symbol	Ctrl.	Buffer Type	Function
20	P00.9	I	SLOW / PU1 / VEXT / ES1	General-purpose input
	GTM_TIM4_IN0_7			Mux input channel 0 of TIM module 4
	GTM_TIM1_IN0_1			Mux input channel 0 of TIM module 1
	GTM_TIM0_IN0_1			Mux input channel 0 of TIM module 0
	CCU61_CC62INC			T12 capture input 62
	SENT_SENT8B			Receive input channel 8
	CCU61_CCPOS2A			Hall capture input 2
	EDSADC_DSCIN1A			Modulator clock input, channel 1
	EDSADC_ITR3F			Trigger/Gate input, channel 3
	GPT120_T4EUDA			Count direction control input of timer T4
	CCU60_T13HRC			External timer start 13
	CIF_HSYNC			horizontal synchronization signal input
	CCU60_T12HRC			External timer start 12
	EVADC_G9CH3			AI
	EDSADC_EDS4NB		Negative analog input channel 4, pin B	
	P00.9	O0	General-purpose output	
	GTM_TOUT18	O1	GTM muxed output	
	QSPI3_SLSO7	O2	Master slave select output	
	ASCLIN3_ARTS	O3	Ready to send output	
	EDSADC_DSCOUT1	O4	Modulator clock output	
ASCLIN4_ATX	O5	Transmit output		
SENT_SPC8	O6	Transmit output		
CCU61_CC62	O7	T12 PWM channel 62		
IOM_MON1_10		Monitor input 1		
IOM_REF1_11		Reference input 1		

TC37xEXT Pin Definition and Functions LQFP-176 Package Pinning of

Table 2-39 Port 00 Functions (cont'd)

Pin	Symbol	Ctrl.	Buffer Type	Function
21	P00.10	I	SLOW / PU1 / VEXT / ES1	General-purpose input
	GTM_TIM4_IN1_11			Mux input channel 1 of TIM module 4
	GTM_TIM1_IN1_1			Mux input channel 1 of TIM module 1
	GTM_TIM0_IN1_1			Mux input channel 1 of TIM module 0
	SENT_SENT9B			Receive input channel 9
	EDSADC_DSDIN1A			Digital datastream input, channel 1
	EVADC_G9CH2			Analog input channel 2, group 9
	EDSADC_EDS4PB	AI		Positive analog input channel 4, pin B
	P00.10			O0
	GTM_TOUT19	O1	GTM muxed output	
	ASCLIN4_ASCLK	O2	Shift clock output	
	—	O3	Reserved	
	—	O4	Reserved	
	—	O5	Reserved	
	SENT_SPC9	O6	Transmit output	
	CCU61_COUT63	O7		T13 PWM channel 63
	IOM_MON1_7			Monitor input 1
IOM_REF1_7	Reference input 1			
22	P00.11	I	SLOW / PU1 / VEXT / ES1	General-purpose input
	GTM_TIM4_IN2_11			Mux input channel 2 of TIM module 4
	GTM_TIM1_IN2_1			Mux input channel 2 of TIM module 1
	GTM_TIM0_IN2_1			Mux input channel 2 of TIM module 0
	CCU60_CTRAPA			Trap input capture
	EDSADC_DSCIN0A			Modulator clock input, channel 0
	CCU61_T12HRE			External timer start 12
	SENT_SENT10B	Receive input channel 10		
	EVADC_G9CH1	AI		Analog input channel 1, group 9
	EVADC_FC3CH0			Analog input FC channel 3
	P00.11	O0	General-purpose output	
	GTM_TOUT20	O1	GTM muxed output	
	ASCLIN4_ASLSO	O2	Slave select signal output	
	—	O3	Reserved	
	EDSADC_DSCOUT0	O4	Modulator clock output	
	—	O5	Reserved	
	—	O6	Reserved	
—	O7	Reserved		

TC37xEXT Pin Definition and Functions LQFP-176 Package Pinning of

Table 2-39 Port 00 Functions (cont'd)

Pin	Symbol	Ctrl.	Buffer Type	Function
23	P00.12	I	SLOW / PU1 / VEXT / ES1	General-purpose input
	GTM_TIM4_IN3_11			Mux input channel 3 of TIM module 4
	GTM_TIM1_IN3_1			Mux input channel 3 of TIM module 1
	GTM_TIM0_IN3_1			Mux input channel 3 of TIM module 0
	ASCLIN3_ACTSA			Clear to send input
	EDSADC_DSDIN0A			Digital datastream input, channel 0
	ASCLIN4_ARXA			Receive input
	SENT_SENT11B			Receive input channel 11
	EVADC_G9CH0			AI
	EVADC_FC2CH0	Analog input FC channel 2		
	P00.12	O0	General-purpose output	
	GTM_TOUT21	O1	GTM muxed output	
	—	O2	Reserved	
	—	O3	Reserved	
	—	O4	Reserved	
	—	O5	Reserved	
	—	O6	Reserved	
	CCU61_COUT63	O7	T13 PWM channel 63	
	IOM_MON1_7		Monitor input 1	
	IOM_REF1_7		Reference input 1	

TC37xEXT Pin Definition and Functions LQFP-176 Package Pinning of

Table 2-40 Port 02 Functions

Pin	Symbol	Ctrl.	Buffer Type	Function
1	P02.0	I	FAST / PU1 / VEXT / ES	General-purpose input
	GTM_TIM1_IN0_2			Mux input channel 0 of TIM module 1
	GTM_TIM0_IN0_2			Mux input channel 0 of TIM module 0
	CCU61_CC60INB			T12 capture input 60
	ASCLIN2_ARXG			Receive input
	CCU60_CC60INA			T12 capture input 60
	SCU_E_REQ3_2			ERU Channel 3 inputs 0 to 5 (0 is the LSB and 5 is the MSB)
	CIF_D0			sensor pixel data input
	GTM_DTMA0_0			CDTM0_DTM4
	P02.0			O0
	GTM_TOUT0	O1	GTM muxed output	
	IOM_REF0_0	O2	Reference input 0	
	ASCLIN2_ATX		Transmit output	
	IOM_MON2_14		Monitor input 2	
	IOM_REF2_14	O3	Reference input 2	
	QSPI3_SLSO1		Master slave select output	
	EDSADC_CGPWMN	O4	Negative carrier generator output	
	CAN00_TXD	O5	CAN transmit output node 0	
	IOM_MON2_5	O6	Monitor input 2	
	IOM_REF2_5		Reference input 2	
	ERAY0_TXDA	O7	Transmit Channel A	
	CCU60_CC60	O7	T12 PWM channel 60	
	IOM_MON1_2		Monitor input 1	
	IOM_REF1_6		Reference input 1	

TC37xEXT Pin Definition and Functions LQFP-176 Package Pinning of

Table 2-40 Port 02 Functions (cont'd)

Pin	Symbol	Ctrl.	Buffer Type	Function
2	P02.1	I	SLOW / PU1 / VEXT / ES	General-purpose input
	GTM_TIM1_IN1_2			Mux input channel 1 of TIM module 1
	GTM_TIM0_IN1_2			Mux input channel 1 of TIM module 0
	ERAY0_RXDA2			Receive Channel A2
	ASCLIN2_ARXB			Receive input
	CAN00_RXDA			CAN receive input node 0
	SCU_E_REQ2_1			ERU Channel 2 inputs 0 to 5 (0 is the LSB and 5 is the MSB)
	CIF_D1			sensor pixel data input
	P02.1			O0
	GTM_TOUT1	O1	GTM muxed output	
	IOM_REF0_1	O2	Reference input 0	
	QSPI4_SLSO7		Master slave select output	
	QSPI3_SLSO2	O3	Master slave select output	
	EDSADC_CGPWMP	O4	Positive carrier generator output	
	—	O5	Reserved	
	—	O6	Reserved	
	CCU60_COUT60	O7	T12 PWM channel 60	
	IOM_MON1_3		Monitor input 1	
	IOM_REF1_3		Reference input 1	

TC37xEXT Pin Definition and Functions LQFP-176 Package Pinning of

Table 2-40 Port 02 Functions (cont'd)

Pin	Symbol	Ctrl.	Buffer Type	Function
3	P02.2	I	FAST / PU1 / VEXT / ES	General-purpose input
	GTM_TIM1_IN2_2			Mux input channel 2 of TIM module 1
	GTM_TIM0_IN2_2			Mux input channel 2 of TIM module 0
	CCU61_CC61INB			T12 capture input 61
	CCU60_CC61INA			T12 capture input 61
	CIF_D2			sensor pixel data input
	SENT_SENT14B			Receive input channel 14
	P02.2			O0
	GTM_TOUT2	O1	GTM muxed output	
	IOM_REF0_2	O2	Reference input 0	
	ASCLIN1_ATX		Transmit output	
	IOM_MON2_13		Monitor input 2	
	IOM_REF2_13	Reference input 2		
	QSPI3_SLSO3	O3	Master slave select output	
	PSI5_TX0	O4	TXD outputs (send data)	
	IOM_MON1_14	O5	Monitor input 1	
	IOM_REF1_14		Reference input 1	
	CAN02_TXD		CAN transmit output node 2	
	IOM_MON2_7	Monitor input 2		
	IOM_REF2_7	Reference input 2		
	ERAY0_TXDB	O6	Transmit Channel B	
	CCU60_CC61	O7	T12 PWM channel 61	
	IOM_MON1_1	Monitor input 1		
	IOM_REF1_5	Reference input 1		

TC37xEXT Pin Definition and Functions LQFP-176 Package Pinning of

Table 2-40 Port 02 Functions (cont'd)

Pin	Symbol	Ctrl.	Buffer Type	Function
4	P02.3	I	SLOW / PU1 / VEXT / ES	General-purpose input
	GTM_TIM1_IN3_2			Mux input channel 3 of TIM module 1
	GTM_TIM0_IN3_2			Mux input channel 3 of TIM module 0
	EDSADC_DSCIN5B			Modulator clock input, channel 5
	ERAY0_RXDB2			Receive Channel B2
	CAN02_RXDB			CAN receive input node 2
	ASCLIN1_ARXG			Receive input
	MSC1_SD11			Upstream asynchronous input signal
	PSI5_RX0B			RXD inputs (receive data) channel 0
	CIF_D3			sensor pixel data input
	SENT_SENT13B			Receive input channel 13
	P02.3	O0	General-purpose output	
	GTM_TOUT3	O1	GTM muxed output	
	IOM_REF0_3		Reference input 0	
	ASCLIN2_ASLSO	O2	Slave select signal output	
	QSPI3_SLSO4	O3	Master slave select output	
	EDSADC_DSCOUT5	O4	Modulator clock output	
	—	O5	Reserved	
	—	O6	Reserved	
CCU60_COUT61	O7	T12 PWM channel 61		
IOM_MON1_4		Monitor input 1		
IOM_REF1_2		Reference input 1		

TC37xEXT Pin Definition and Functions LQFP-176 Package Pinning of

Table 2-40 Port 02 Functions (cont'd)

Pin	Symbol	Ctrl.	Buffer Type	Function
5	P02.4	I	FAST / PU1 / VEXT / ES	General-purpose input
	GTM_TIM1_IN4_1			Mux input channel 4 of TIM module 1
	GTM_TIM0_IN4_1			Mux input channel 4 of TIM module 0
	CCU61_CC62INB			T12 capture input 62
	EDSADC_DSDIN5B			Digital datastream input, channel 5
	QSPI3_SLSIA			Slave select input
	CCU60_CC62INA			T12 capture input 62
	I2C0_SDAA			Serial Data Input 0
	CAN11_RXDA			CAN receive input node 1
	CAN0_ECTT1			External CAN time trigger input
	CIF_D4			sensor pixel data input
	SENT_SENT12B			Receive input channel 12
	P02.4			O0
	GTM_TOUT4	O1	GTM muxed output	
	IOM_REF0_4		Reference input 0	
	ASCLIN2_ASCLK	O2	Shift clock output	
	QSPI3_SLSO0	O3	Master slave select output	
	PSI5S_CLK	O4	PSI5S CLK is a clock that can be used on a pin to drive the external PHY.	
	I2C0_SDA	O5	Serial Data Output	
	ERAY0_TXENA	O6	Transmit Enable Channel A	
CCU60_CC62	O7	T12 PWM channel 62		
IOM_MON1_0		Monitor input 1		
IOM_REF1_4		Reference input 1		

TC37xEXT Pin Definition and Functions LQFP-176 Package Pinning of

Table 2-40 Port 02 Functions (cont'd)

Pin	Symbol	Ctrl.	Buffer Type	Function	
6	P02.5	I	FAST / PU1 / VEXT / ES	General-purpose input	
	GTM_TIM1_IN5_1			Mux input channel 5 of TIM module 1	
	GTM_TIM0_IN5_1			Mux input channel 5 of TIM module 0	
	EDSADC_DSCIN4B			Modulator clock input, channel 4	
	I2C0_SCLA			Serial Clock Input 0	
	PSI5_RX1B			RXD inputs (receive data) channel 1	
	PSI5S_RXB			RX data input	
	QSPI3_MRSTA			Master SPI data input	
	SENT_SENT3C			Receive input channel 3	
	CAN0_ECTT2			External CAN time trigger input	
	CIF_D5			sensor pixel data input	
	P02.5			O0	General-purpose output
	GTM_TOUT5			O1	GTM muxed output
	IOM_REF0_5		Reference input 0		
	CAN11_TXD	O2	CAN transmit output node 1		
	QSPI3_MRST	O3	Slave SPI data output		
	IOM_MON2_3		Monitor input 2		
	IOM_REF2_3		Reference input 2		
	EDSADC_DSCOUT4	O4	Modulator clock output		
	I2C0_SCL	O5	Serial Clock Output		
ERAY0_TXENB	O6	Transmit Enable Channel B			
CCU60_COUT62	O7	T12 PWM channel 62			
IOM_MON1_5		Monitor input 1			
IOM_REF1_1		Reference input 1			

TC37xEXT Pin Definition and Functions LQFP-176 Package Pinning of

Table 2-40 Port 02 Functions (cont'd)

Pin	Symbol	Ctrl.	Buffer Type	Function
7	P02.6	I	FAST / PU1 / VEXT / ES	General-purpose input
	GTM_TIM3_IN0_10			Mux input channel 0 of TIM module 3
	GTM_TIM1_IN6_1			Mux input channel 6 of TIM module 1
	GTM_TIM0_IN6_1			Mux input channel 6 of TIM module 0
	CCU60_CC60INC			T12 capture input 60
	SENT_SENT2C			Receive input channel 2
	EDSADC_DSDIN4B			Digital datastream input, channel 4
	EDSADC_ITR5E			Trigger/Gate input, channel 5
	GPT120_T3INA			Trigger/gate input of core timer T3
	CCU60_CCPOS0A			Hall capture input 0
	CCU61_T12HRB			External timer start 12
	QSPI3_MTSRA			Slave SPI data input
	CIF_D6			sensor pixel data input
	P02.6			O0
	GTM_TOUT6	O1	GTM muxed output	
	IOM_REF0_6		Reference input 0	
	PSI5S_TX	O2	TX data output	
	QSPI3_MTSR	O3	Master SPI data output	
	PSI5_TX1	O4	TXD outputs (send data)	
	IOM_MON1_15		Monitor input 1	
EVADC_EMUX00	O5	Control of external analog multiplexer interface 0		
—	O6	Reserved		
CCU60_CC60	O7	T12 PWM channel 60		
IOM_MON1_2		Monitor input 1		
IOM_REF1_6		Reference input 1		

TC37xEXT Pin Definition and Functions LQFP-176 Package Pinning of

Table 2-40 Port 02 Functions (cont'd)

Pin	Symbol	Ctrl.	Buffer Type	Function
8	P02.7	I	FAST / PU1 / VEXT / ES	General-purpose input
	GTM_TIM3_IN1_10			Mux input channel 1 of TIM module 3
	GTM_TIM1_IN7_1			Mux input channel 7 of TIM module 1
	GTM_TIM0_IN7_1			Mux input channel 7 of TIM module 0
	CCU60_CC61INC			T12 capture input 61
	SENT_SENT1C			Receive input channel 1
	EDSADC_DSCIN3B			Modulator clock input, channel 3
	EDSADC_ITR4E			Trigger/Gate input, channel 4
	GPT120_T3EUDA			Count direction control input of core timer T3
	CCU60_CCPOS1A			Hall capture input 1
	CIF_D7			sensor pixel data input
	QSPI3_SCLKA			Slave SPI clock inputs
	CCU61_T13HRB			External timer start 13
	P02.7			O0
	GTM_TOUT7	O1	GTM muxed output	
	IOM_REF0_7		Reference input 0	
	—	O2	Reserved	
	QSPI3_SCLK	O3	Master SPI clock output	
	EDSADC_DSCOUT3	O4	Modulator clock output	
	EVADC_EMUX01	O5	Control of external analog multiplexer interface 0	
SENT_SPC1	O6	Transmit output		
CCU60_CC61	O7	T12 PWM channel 61		
IOM_MON1_1		Monitor input 1		
IOM_REF1_5		Reference input 1		

TC37xEXT Pin Definition and Functions LQFP-176 Package Pinning of

Table 2-40 Port 02 Functions (cont'd)

Pin	Symbol	Ctrl.	Buffer Type	Function
9	P02.8	I	SLOW / PU1 / VEXT / ES	General-purpose input
	GTM_TIM3_IN2_10			Mux input channel 2 of TIM module 3
	GTM_TIM3_IN0_2			Mux input channel 0 of TIM module 3
	GTM_TIM2_IN0_2			Mux input channel 0 of TIM module 2
	CCU60_CC62INC			T12 capture input 62
	SENT_SENT0C			Receive input channel 0
	CCU60_CCPOS2A			Hall capture input 2
	EDSADC_DSDIN3B			Digital datastream input, channel 3
	EDSADC_ITR3E			Trigger/Gate input, channel 3
	GPT120_T4INA			Trigger/gate input of timer T4
	CCU61_T12HRC			External timer start 12
	CIF_D8			sensor pixel data input
	CCU61_T13HRC			External timer start 13
	GTM_DTMA0_1			CDTM0_DTM4
	P02.8			O0
	GTM_TOUT8	O1	GTM muxed output	
	IOM_REF0_8		Reference input 0	
	QSPI3_SLSO5	O2	Master slave select output	
	ASCLIN8_ASCLK	O3	Shift clock output	
	—	O4	Reserved	
EVADC_EMUX02	O5	Control of external analog multiplexer interface 0		
GETH_MDC	O6	MDIO clock		
CCU60_CC62	O7	T12 PWM channel 62		
IOM_MON1_0		Monitor input 1		
IOM_REF1_4		Reference input 1		

TC37xEXT Pin Definition and Functions LQFP-176 Package Pinning of

Table 2-41 Port 10 Functions

Pin	Symbol	Ctrl.	Buffer Type	Function
168	P10.0	I	SLOW / PU1 / VEXT / ES	General-purpose input
	GTM_TIM4_IN0_12			Mux input channel 0 of TIM module 4
	GTM_TIM1_IN4_2			Mux input channel 4 of TIM module 1
	GTM_TIM0_IN4_2			Mux input channel 4 of TIM module 0
	GPT120_T6EUDB			Count direction control input of core timer T6
	ASCLIN11_ARXA			Receive input
	GETH_RXERC			Receive Error MII
	P10.0	O0		General-purpose output
	GTM_TOUT102	O1		GTM muxed output
	ASCLIN11_ATX	O2		Transmit output
	QSPI1_SLSO10	O3		Master slave select output
	—	O4		Reserved
	—	O5		Reserved
	—	O6		Reserved
—	O7		Reserved	
169	P10.1	I	FAST / PU1 / VEXT / ES	General-purpose input
	GTM_TIM4_IN4_12			Mux input channel 4 of TIM module 4
	GTM_TIM1_IN1_3			Mux input channel 1 of TIM module 1
	GTM_TIM0_IN1_3			Mux input channel 1 of TIM module 0
	GPT120_T5EUDB			Count direction control input of timer T5
	QSPI1_MRSTA			Master SPI data input
	GTM_DTMT0_1			CDTM0_DTM0
	P10.1	O0		General-purpose output
	GTM_TOUT103	O1		GTM muxed output
	QSPI1_MTISR	O2		Master SPI data output
	QSPI1_MRST	O3		Slave SPI data output
	IOM_MON2_1			Monitor input 2
	IOM_REF2_1			Reference input 2
	MSC0_EN1	O4		Chip Select
EVADC_FC1BFLOUT	O5		Boundary flag output, FC channel 1	
—	O6		Reserved	
—	O7		Reserved	

TC37xEXT Pin Definition and Functions LQFP-176 Package Pinning of

Table 2-41 Port 10 Functions (cont'd)

Pin	Symbol	Ctrl.	Buffer Type	Function
170	P10.2	I	FAST / PU1 / VEXT / ES	General-purpose input
	GTM_TIM4_IN5_12			Mux input channel 5 of TIM module 4
	GTM_TIM1_IN2_3			Mux input channel 2 of TIM module 1
	GTM_TIM0_IN2_3			Mux input channel 2 of TIM module 0
	CAN02_RXDE			CAN receive input node 2
	MSC0_SD11			Upstream assynchronous input signal
	QSPI1_SCLKA			Slave SPI clock inputs
	GPT120_T6INB			Trigger/gate input of core timer T6
	SCU_E_REQ2_0			ERU Channel 2 inputs 0 to 5 (0 is the LSB and 5 is the MSB)
	GTM_DTMT2_2			CDTM2_DTM0
	P10.2			O0
	GTM_TOUT104	O1	GTM muxed output	
	IOM_MON2_9		Monitor input 2	
	—	O2	Reserved	
	QSPI1_SCLK	O3	Master SPI clock output	
	MSC0_EN0	O4	Chip Select	
	EVADC_FC3BFLOUT	O5	Boundary flag output, FC channel 3	
	—	O6	Reserved	
	—	O7	Reserved	

TC37xEXT Pin Definition and Functions LQFP-176 Package Pinning of

Table 2-41 Port 10 Functions (cont'd)

Pin	Symbol	Ctrl.	Buffer Type	Function
171	P10.3	I	FAST / PU1 / VEXT / ES	General-purpose input
	GTM_TIM4_IN6_10			Mux input channel 6 of TIM module 4
	GTM_TIM1_IN3_3			Mux input channel 3 of TIM module 1
	GTM_TIM0_IN3_3			Mux input channel 3 of TIM module 0
	QSPI1_MTSRA			Slave SPI data input
	SCU_E_REQ3_0			ERU Channel 3 inputs 0 to 5 (0 is the LSB and 5 is the MSB)
	GPT120_T5INB			Trigger/gate input of timer T5
	P10.3			O0
	GTM_TOUT105	O1	GTM muxed output	
	IOM_MON2_10		Monitor input 2	
	—	O2	Reserved	
	QSPI1_MTSR	O3	Master SPI data output	
	MSC0_EN0	O4	Chip Select	
	—	O5	Reserved	
	CAN02_TXD	O6	CAN transmit output node 2	
	IOM_MON2_7		Monitor input 2	
	IOM_REF2_7		Reference input 2	
	—	O7	Reserved	
	172	P10.4	I	FAST / PU1 / VEXT / ES
GTM_TIM4_IN7_3		Mux input channel 7 of TIM module 4		
GTM_TIM1_IN6_2		Mux input channel 6 of TIM module 1		
GTM_TIM0_IN6_2		Mux input channel 6 of TIM module 0		
QSPI1_MTSRC		Slave SPI data input		
CCU60_CCPOS0C		Hall capture input 0		
GPT120_T3INB		Trigger/gate input of core timer T3		
ASCLIN11_ARXB		Receive input		
P10.4		O0	General-purpose output	
GTM_TOUT106		O1	GTM muxed output	
IOM_MON2_11			Monitor input 2	
—		O2	Reserved	
QSPI1_SLSO8		O3	Master slave select output	
QSPI1_MTSR		O4	Master SPI data output	
MSC0_EN0		O5	Chip Select	
—		O6	Reserved	
—		O7	Reserved	

TC37xEXT Pin Definition and Functions LQFP-176 Package Pinning of

Table 2-41 Port 10 Functions (cont'd)

Pin	Symbol	Ctrl.	Buffer Type	Function
173	P10.5	I	SLOW / PU2 / VEXT / ES	General-purpose input
	GTM_TIM4_IN3_13			Mux input channel 3 of TIM module 4
	GTM_TIM1_IN2_4			Mux input channel 2 of TIM module 1
	GTM_TIM0_IN2_4			Mux input channel 2 of TIM module 0
	PMS_HWCFG4IN			HWCFG4 pin input
	CAN20_RXDA			CAN receive input node 0
	MSC0_INJ1			Injection signal from port
	P10.5	O0	General-purpose output	
	GTM_TOUT107	O1	GTM muxed output	
	IOM_REF2_9	O2	Reference input 2	
	ASCLIN2_ATX		Transmit output	
	IOM_MON2_14		Monitor input 2	
	IOM_REF2_14	Reference input 2		
	QSPI3_SLSO8	O3	Master slave select output	
	QSPI1_SLSO9	O4	Master slave select output	
	GPT120_T6OUT	O5	External output for overflow/underflow detection of core timer T6	
	ASCLIN2_ASLSO	O6	Slave select signal output	
—	O7	Reserved		
174	P10.6	I	SLOW / PU2 / VEXT / ES	General-purpose input
	GTM_TIM4_IN2_13			Mux input channel 2 of TIM module 4
	GTM_TIM1_IN3_4			Mux input channel 3 of TIM module 1
	GTM_TIM0_IN3_4			Mux input channel 3 of TIM module 0
	ASCLIN2_ARXD			Receive input
	QSPI3_MTSRB			Slave SPI data input
	PMS_HWCFG5IN			HWCFG5 pin input
	P10.6	O0	General-purpose output	
	GTM_TOUT108	O1	GTM muxed output	
	IOM_REF2_10	O2	Reference input 2	
	ASCLIN2_ASCLK		Shift clock output	
	QSPI3_MTSR		Master SPI data output	
	GPT120_T3OUT	O4	External output for overflow/underflow detection of core timer T3	
	CAN20_TXD	O5	CAN transmit output node 0	
	QSPI1_MRST	O6	Slave SPI data output	
	IOM_MON2_1	O7	Monitor input 2	
	IOM_REF2_1		Reference input 2	
—	O7	Reserved		

TC37xEXT Pin Definition and Functions LQFP-176 Package Pinning of

Table 2-41 Port 10 Functions (cont'd)

Pin	Symbol	Ctrl.	Buffer Type	Function
175	P10.7	I	SLOW / PU1 / VEXT / ES	General-purpose input
	GTM_TIM1_IN0_3			Mux input channel 0 of TIM module 1
	GTM_TIM0_IN0_3			Mux input channel 0 of TIM module 0
	GPT120_T3EUDB			Count direction control input of core timer T3
	ASCLIN2_ACTSA			Clear to send input
	QSPI3_MRSTB			Master SPI data input
	SCU_E_REQ0_2			ERU Channel 0 inputs 0 to 5 (0 is the LSB and 5 is the MSB)
	CCU60_CCPOS1C			Hall capture input 1
	P10.7			O0
	GTM_TOUT109	O1	GTM muxed output	
	IOM_REF2_11	O2	Reference input 2	
	—		Reserved	
	QSPI3_MRST		O3	Slave SPI data output
	IOM_MON2_3	O3	Monitor input 2	
	IOM_REF2_3		Reference input 2	
	—	O4	Reserved	
	CAN20_TXD	O5	CAN transmit output node 0	
	CAN12_TXD	O6	CAN transmit output node 2	
	—	O7	Reserved	

TC37xEXT Pin Definition and Functions LQFP-176 Package Pinning of

Table 2-41 Port 10 Functions (cont'd)

Pin	Symbol	Ctrl.	Buffer Type	Function
176	P10.8	I	SLOW / PU1 / VEXT / ES	General-purpose input
	GTM_TIM4_IN0_13			Mux input channel 0 of TIM module 4
	GTM_TIM1_IN5_2			Mux input channel 5 of TIM module 1
	GTM_TIM0_IN5_2			Mux input channel 5 of TIM module 0
	CAN12_RXDB			CAN receive input node 2
	GPT120_T4INB			Trigger/gate input of timer T4
	QSPI3_SCLKB			Slave SPI clock inputs
	SCU_E_REQ1_2			ERU Channel 1 inputs 0 to 5 (0 is the LSB and 5 is the MSB)
	CCU60_CCPOS2C			Hall capture input 2
	CAN20_RXDB			CAN receive input node 0
	P10.8	O0	General-purpose output	
	GTM_TOUT110	O1	GTM muxed output	
	ASCLIN2_ARTS	O2	Ready to send output	
	QSPI3_SCLK	O3	Master SPI clock output	
	—	O4	Reserved	
	—	O5	Reserved	
	—	O6	Reserved	
	—	O7	Reserved	

Table 2-42 Port 11 Functions

Pin	Symbol	Ctrl.	Buffer Type	Function
160	P11.2	I	RFast / PU1 / VFLEX / ES	General-purpose input
	GTM_TIM3_IN1_3			Mux input channel 1 of TIM module 3
	GTM_TIM2_IN1_3			Mux input channel 1 of TIM module 2
	P11.2	O0	General-purpose output	
	GTM_TOUT95	O1	GTM muxed output	
	—	O2	Reserved	
	QSPI0_SLSO5	O3	Master slave select output	
	QSPI1_SLSO5	O4	Master slave select output	
	MSC0_EN1	O5	Chip Select	
	GETH_TXD1	O6	Transmit Data	
	CCU60_COUT63	O7	T13 PWM channel 63	
	IOM_MON1_6		Monitor input 1	
	IOM_REF1_0		Reference input 1	

TC37xEXT Pin Definition and Functions LQFP-176 Package Pinning of

Table 2-42 Port 11 Functions (cont'd)

Pin	Symbol	Ctrl.	Buffer Type	Function	
161	P11.3	I	RFAST / PU1 / VFLEX / ES	General-purpose input	
	GTM_TIM3_IN2_2			Mux input channel 2 of TIM module 3	
	GTM_TIM2_IN2_2			Mux input channel 2 of TIM module 2	
	MSC0_SDI3			Upstream asynchronous input signal	
	QSPI1_MRSTB			Master SPI data input	
	P11.3			O0	General-purpose output
	GTM_TOUT96			O1	GTM muxed output
	—			O2	Reserved
	QSPI1_MRST			O3	Slave SPI data output
	IOM_MON2_1				Monitor input 2
	IOM_REF2_1				Reference input 2
	ERAY0_TXDA			O4	Transmit Channel A
	—			O5	Reserved
	GETH_TXD0			O6	Transmit Data
	CCU60_COUT62			O7	T12 PWM channel 62
	IOM_MON1_5				Monitor input 1
IOM_REF1_1	Reference input 1				
162	P11.6	I	RFAST / PU1 / VFLEX / ES	General-purpose input	
	GTM_TIM3_IN3_2			Mux input channel 3 of TIM module 3	
	GTM_TIM2_IN3_2			Mux input channel 3 of TIM module 2	
	QSPI1_SCLKB			Slave SPI clock inputs	
	P11.6			O0	General-purpose output
	GTM_TOUT97			O1	GTM muxed output
	ERAY0_TXENB			O2	Transmit Enable Channel B
	QSPI1_SCLK			O3	Master SPI clock output
	ERAY0_TXENA			O4	Transmit Enable Channel A
	MSC0_FCLP			O5	Shift-clock direct part of the differential signal
	GETH_TXEN			O6	Transmit Enable MII and RMII
	GETH_TCTL				Transmit Control for RGMII
	CCU60_COUT61			O7	T12 PWM channel 61
	IOM_MON1_4				Monitor input 1
	IOM_REF1_2				Reference input 1

TC37xEXT Pin Definition and Functions LQFP-176 Package Pinning of

Table 2-42 Port 11 Functions (cont'd)

Pin	Symbol	Ctrl.	Buffer Type	Function
163	P11.9	I	FAST / RGMII_Input / PU1 / VFLEX / ES	General-purpose input
	GTM_TIM3_IN4_2			Mux input channel 4 of TIM module 3
	GTM_TIM2_IN4_2			Mux input channel 4 of TIM module 2
	QSPI1_MTSRB			Slave SPI data input
	ERAY0_RXDA1			Receive Channel A1
	GETH_RXD1A			Receive Data 1 MII, RMI and RGMII (RGMII can use RXD1A only)
	P11.9	O0	FAST / RGMII_Input / PU1 / VFLEX / ES	General-purpose output
	GTM_TOUT98	O1		GTM muxed output
	—	O2		Reserved
	QSPI1_MTSR	O3		Master SPI data output
	—	O4		Reserved
	MSC0_SOP	O5		Data output - direct part of the differential signal
	—	O6		Reserved
	CCU60_COUT60	O7		T12 PWM channel 60
	IOM_MON1_3			Monitor input 1
	IOM_REF1_3			Reference input 1

TC37xEXT Pin Definition and Functions LQFP-176 Package Pinning of

Table 2-42 Port 11 Functions (cont'd)

Pin	Symbol	Ctrl.	Buffer Type	Function	
165	P11.10	I	FAST / RGMII_Input / PU1 / VFLEX / ES	General-purpose input	
	GTM_TIM3_IN5_2			Mux input channel 5 of TIM module 3	
	GTM_TIM2_IN5_2			Mux input channel 5 of TIM module 2	
	GTM_TIM2_IN0_9			Mux input channel 0 of TIM module 2	
	CAN03_RXDD			CAN receive input node 3	
	ERAY0_RXDB1			Receive Channel B1	
	ASCLIN1_ARXE			Receive input	
	SCU_E_REQ6_3			ERU Channel 6 inputs 0 to 5 (0 is the LSB and 5 is the MSB)	
	MSC0_SDI0			Upstream asynchronous input signal	
	GETH_RXD0A			Receive Data 0 MII, RMI and RGMII (RGMII can use RXD0A only)	
	QSPI1_SLSIA			Slave select input	
	P11.10			O0	General-purpose output
	GTM_TOUT99			O1	GTM muxed output
	—	O2	Reserved		
	QSPI0_SLSO3	O3	Master slave select output		
	QSPI1_SLSO3	O4	Master slave select output		
	—	O5	Reserved		
	—	O6	Reserved		
	CCU60_CC62	O7	T12 PWM channel 62		
	IOM_MON1_0		Monitor input 1		
IOM_REF1_4		Reference input 1			

TC37xEXT Pin Definition and Functions LQFP-176 Package Pinning of

Table 2-42 Port 11 Functions (cont'd)

Pin	Symbol	Ctrl.	Buffer Type	Function
166	P11.11	I	FAST / RGMII_In put / PU1 / VFLEX / ES	General-purpose input
	GTM_TIM3_IN6_2			Mux input channel 6 of TIM module 3
	GTM_TIM3_IN0_14			Mux input channel 0 of TIM module 3
	GTM_TIM2_IN6_2			Mux input channel 6 of TIM module 2
	GETH_CRSDVA			Carrier Sense / Data Valid combi-signal for RMII
	GETH_RXDVA			Receive Data Valid MII
	GETH_CRSB			Carrier Sense MII
	GETH_RCTLA			Receive Control for RGMII
	P11.11			O0
	GTM_TOUT100	O1	GTM muxed output	
	—	O2	Reserved	
	QSPIO_SLSO4	O3	Master slave select output	
	QSPI1_SLSO4	O4	Master slave select output	
	MSC0_EN0	O5	Chip Select	
	ERAY0_TXENB	O6	Transmit Enable Channel B	
	CCU60_CC61	O7	T12 PWM channel 61	
	IOM_MON1_1		Monitor input 1	
IOM_REF1_5		Reference input 1		
167	P11.12	I	FAST / RGMII_In put / PU1 / VFLEX / ES	General-purpose input
	GTM_TIM3_IN7_2			Mux input channel 7 of TIM module 3
	GTM_TIM2_IN7_2			Mux input channel 7 of TIM module 2
	GETH_REFCLKA			Reference Clock input for RMII (50 MHz)
	GETH_TXCLKB			Transmit Clock Input for MII
	GETH_RXCLKA			Receive Clock MII
	P11.12	O0	General-purpose output	
	GTM_TOUT101	O1	GTM muxed output	
	ASCLIN1_ATX	O2	Transmit output	
	IOM_MON2_13		Monitor input 2	
	IOM_REF2_13		Reference input 2	
	GTM_CLK2	O3	CGM generated clock	
	ERAY0_TXDB	O4	Transmit Channel B	
	CAN03_TXD	O5	CAN transmit output node 3	
	IOM_MON2_8		Monitor input 2	
	IOM_REF2_8		Reference input 2	
	CCU_EXTCLK1	O6	External Clock 1	
CCU60_CC60	O7	T12 PWM channel 60		
IOM_MON1_2		Monitor input 1		
IOM_REF1_6		Reference input 1		

TC37xEXT Pin Definition and Functions LQFP-176 Package Pinning of

Table 2-43 Port 13 Functions

Pin	Symbol	Ctrl.	Buffer Type	Function
156	P13.0	I	LVDS_TX / FAST / PU1 / VEXT / ES6	General-purpose input
	GTM_TIM3_IN5_3			Mux input channel 5 of TIM module 3
	GTM_TIM2_IN5_3			Mux input channel 5 of TIM module 2
	ASCLIN10_ARXC			Receive input
	P13.0	O0		General-purpose output
	GTM_TOUT91	O1		GTM muxed output
	ASCLIN10_ATX	O2		Transmit output
	QSPI2_SCLKN	O3		Master SPI clock output (LVDS N line)
	MSC0_EN1	O4		Chip Select
	MSC0_FCLN	O5		Shift-clock inverted part of the differential signal
	—	O6		Reserved
CAN10_TXD	O7	CAN transmit output node 0		
157	P13.1	I	LVDS_TX / FAST / PU1 / VEXT / ES6	General-purpose input
	GTM_TIM3_IN6_3			Mux input channel 6 of TIM module 3
	GTM_TIM2_IN6_3			Mux input channel 6 of TIM module 2
	I2C0_SCLB			Serial Clock Input 1
	CAN10_RXDD			CAN receive input node 0
	ASCLIN10_ARXD			Receive input
	P13.1	O0		General-purpose output
	GTM_TOUT92	O1		GTM muxed output
	—	O2		Reserved
	QSPI2_SCLKP	O3		Master SPI clock output (LVDS P line)
	—	O4		Reserved
	MSC0_FCLP	O5		Shift-clock direct part of the differential signal
	I2C0_SCL	O6		Serial Clock Output
	—	O7		Reserved

TC37xEXT Pin Definition and Functions LQFP-176 Package Pinning of

Table 2-43 Port 13 Functions (cont'd)

Pin	Symbol	Ctrl.	Buffer Type	Function
158	P13.2	I	LVDS_TX / FAST / PU1 / VEXT / ES6	General-purpose input
	GTM_TIM3_IN7_3			Mux input channel 7 of TIM module 3
	GTM_TIM2_IN7_3			Mux input channel 7 of TIM module 2
	GPT120_CAPINA			Trigger input to capture value of timer T5 into CAPREL register
	I2C0_SDAB			Serial Data Input 1
	P13.2	O0	General-purpose output	
	GTM_TOUT93	O1	GTM muxed output	
	ASCLIN10_ASCLK	O2	Shift clock output	
	QSPI2_MTSRN	O3	Master SPI data output (LVDS N line)	
	MSC0_FCLP	O4	Shift-clock direct part of the differential signal	
	MSC0_SON	O5	Data output - inverted part of the differential signal	
	I2C0_SDA	O6	Serial Data Output	
	—	O7	Reserved	
159	P13.3	I	LVDS_TX / FAST / PU1 / VEXT / ES6	General-purpose input
	GTM_TIM3_IN0_3			Mux input channel 0 of TIM module 3
	GTM_TIM2_IN0_3			Mux input channel 0 of TIM module 2
	P13.3	O0	General-purpose output	
	GTM_TOUT94	O1	GTM muxed output	
	ASCLIN10_ASLSO	O2	Slave select signal output	
	QSPI2_MTSRP	O3	Master SPI data output (LVDS P line)	
	—	O4	Reserved	
	MSC0_SOP	O5	Data output - direct part of the differential signal	
	—	O6	Reserved	
	—	O7	Reserved	

TC37xEXT Pin Definition and Functions LQFP-176 Package Pinning of

Table 2-44 Port 14 Functions

Pin	Symbol	Ctrl.	Buffer Type	Function
142	P14.0	I	FAST / PU1 / VEXT / ES2	General-purpose input
	GTM_TIM1_IN3_5			Mux input channel 3 of TIM module 1
	GTM_TIM0_IN3_5			Mux input channel 3 of TIM module 0
	P14.0	O0		General-purpose output
	GTM_TOUT80	O1		GTM muxed output
	ASCLIN0_ATX	O2		Transmit output
	IOM_MON2_12			Monitor input 2
	IOM_REF2_12			Reference input 2
	ERAY0_TXDA	O3		Transmit Channel A
	ERAY0_TXDB	O4		Transmit Channel B
	CAN01_TXD	O5		CAN transmit output node 1
	IOM_MON2_6			Monitor input 2
	IOM_REF2_6			Reference input 2
	ASCLIN0_ASCLK	O6		Shift clock output
	CCU60_COUT62	O7		T12 PWM channel 62
	IOM_MON1_5			Monitor input 1
IOM_REF1_1	Reference input 1			

TC37xEXT Pin Definition and Functions LQFP-176 Package Pinning of

Table 2-44 Port 14 Functions (cont'd)

Pin	Symbol	Ctrl.	Buffer Type	Function
143	P14.1	I	FAST / PU1 / VEXT / ES2	General-purpose input
	GTM_TIM1_IN4_3			Mux input channel 4 of TIM module 1
	GTM_TIM0_IN4_3			Mux input channel 4 of TIM module 0
	ERAY0_RXDA3			Receive Channel A3
	ASCLIN0_ARXA			Receive input
	ERAY0_RXDB3			Receive Channel B3
	CAN01_RXDB			CAN receive input node 1
	SCU_E_REQ3_1			ERU Channel 3 inputs 0 to 5 (0 is the LSB and 5 is the MSB)
	PMS_PINAWKP			PINA (P14.1) pin input
	P14.1			O0
	GTM_TOUT81	O1	GTM muxed output	
	ASCLIN0_ATX	O2	Transmit output	
	IOM_MON2_12		Monitor input 2	
	IOM_REF2_12		Reference input 2	
	—	O3	Reserved	
	—	O4	Reserved	
	—	O5	Reserved	
	—	O6	Reserved	
	CCU60_COUT63	O7	T13 PWM channel 63	
	IOM_MON1_6		Monitor input 1	
IOM_REF1_0	Reference input 1			
144	P14.2	I	SLOW / PU2 / VEXT / ES	General-purpose input
	GTM_TIM1_IN5_3			Mux input channel 5 of TIM module 1
	GTM_TIM0_IN5_3			Mux input channel 5 of TIM module 0
	PMS_HWCFG2IN			HWCFG2 pin input
	P14.2	O0	General-purpose output	
	GTM_TOUT82	O1	GTM muxed output	
	ASCLIN2_ATX	O2	Transmit output	
	IOM_MON2_14		Monitor input 2	
	IOM_REF2_14		Reference input 2	
	QSPI2_SLSO1	O3	Master slave select output	
	—	O4	Reserved	
	—	O5	Reserved	
	ASCLIN2_ASCLK	O6	Shift clock output	
	—	O7	Reserved	

TC37xEXT Pin Definition and Functions LQFP-176 Package Pinning of

Table 2-44 Port 14 Functions (cont'd)

Pin	Symbol	Ctrl.	Buffer Type	Function
145	P14.3	I	SLOW / PU2 / VEXT / ES	General-purpose input
	GTM_TIM1_IN6_3			Mux input channel 6 of TIM module 1
	GTM_TIM0_IN6_3			Mux input channel 6 of TIM module 0
	PMS_HWCFG3IN			HWCFG3 pin input
	ASCLIN2_ARXA			Receive input
	MSC0_SDI2			Upstream assynchronous input signal
	SCU_E_REQ1_0			ERU Channel 1 inputs 0 to 5 (0 is the LSB and 5 is the MSB)
	P14.3	O0	General-purpose output	
	GTM_TOUT83	O1	GTM muxed output	
	ASCLIN2_ATX	O2	Transmit output	
	IOM_MON2_14		Monitor input 2	
	IOM_REF2_14		Reference input 2	
	QSPI2_SLSO3	O3	Master slave select output	
	ASCLIN1_ASLSO	O4	Slave select signal output	
	ASCLIN3_ASLSO	O5	Slave select signal output	
	—	O6	Reserved	
	—	O7	Reserved	
146	P14.4	I	SLOW / PU2 / VEXT / ES	General-purpose input
	GTM_TIM1_IN7_2			Mux input channel 7 of TIM module 1
	GTM_TIM0_IN7_2			Mux input channel 7 of TIM module 0
	PMS_HWCFG6IN			HWCFG6 pin input
	GTM_DTMT0_0			CDTM0_DTM0
	P14.4	O0	General-purpose output	
	GTM_TOUT84	O1	GTM muxed output	
	—	O2	Reserved	
	—	O3	Reserved	
	—	O4	Reserved	
	—	O5	Reserved	
	GETH_PPS	O6	Pulse Per Second	
	—	O7	Reserved	

TC37xEXT Pin Definition and Functions LQFP-176 Package Pinning of

Table 2-44 Port 14 Functions (cont'd)

Pin	Symbol	Ctrl.	Buffer Type	Function
147	P14.5	I	FAST / PU2 / VEXT / ES	General-purpose input
	GTM_TIM1_IN0_4			Mux input channel 0 of TIM module 1
	GTM_TIM0_IN0_4			Mux input channel 0 of TIM module 0
	PMS_HWCFG1IN			HWCFG1 pin input
	GTM_DTMA2_0			CDTM2_DTM4
	P14.5			O0
	GTM_TOUT85	O1	GTM muxed output	
	—	O2	Reserved	
	—	O3	Reserved	
	—	O4	Reserved	
	—	O5	Reserved	
	ERAY0_TXDB	O6	Transmit Channel B	
	—	O7	Reserved	
148	P14.6	I	FAST / PU1 / VEXT / ES	General-purpose input
	GTM_TIM1_IN1_4			Mux input channel 1 of TIM module 1
	GTM_TIM0_IN1_4			Mux input channel 1 of TIM module 0
	P14.6	O0	General-purpose output	
	GTM_TOUT86	O1	GTM muxed output	
	—	O2	Reserved	
	QSPI2_SLSO2	O3	Master slave select output	
	CAN13_TXD	O4	CAN transmit output node 3	
	—	O5	Reserved	
	ERAY0_TXENB	O6	Transmit Enable Channel B	
	—	O7	Reserved	

TC37xEXT Pin Definition and Functions LQFP-176 Package Pinning of

Table 2-44 Port 14 Functions (cont'd)

Pin	Symbol	Ctrl.	Buffer Type	Function
149	P14.7	I	SLOW / PU1 / VEXT / ES	General-purpose input
	GTM_TIM4_IN7_10			Mux input channel 7 of TIM module 4
	GTM_TIM1_IN0_5			Mux input channel 0 of TIM module 1
	GTM_TIM0_IN0_5			Mux input channel 0 of TIM module 0
	ERAY0_RXDB0			Receive Channel B0
	CAN10_RXDB			CAN receive input node 0
	CAN13_RXDA			CAN receive input node 3
	ASCLIN9_ARXC			Receive input
	P14.7	O0	General-purpose output	
	GTM_TOUT87	O1	GTM muxed output	
	ASCLIN0_ARTS	O2	Ready to send output	
	QSPI2_SLSO4	O3	Master slave select output	
	ASCLIN9_ATX	O4	Transmit output	
	—	O5	Reserved	
—	O6	Reserved		
—	O7	Reserved		
150	P14.8	I	SLOW / PU1 / VEXT / ES	General-purpose input
	GTM_TIM3_IN2_3			Mux input channel 2 of TIM module 3
	GTM_TIM2_IN2_3			Mux input channel 2 of TIM module 2
	ERAY0_RXDA0			Receive Channel A0
	CAN02_RXDD			CAN receive input node 2
	ASCLIN1_ARXD			Receive input
	P14.8	O0	General-purpose output	
	GTM_TOUT88	O1	GTM muxed output	
	ASCLIN5_ASLSO	O2	Slave select signal output	
	ASCLIN7_ASLSO	O3	Slave select signal output	
	—	O4	Reserved	
	—	O5	Reserved	
	—	O6	Reserved	
	—	O7	Reserved	

TC37xEXT Pin Definition and Functions LQFP-176 Package Pinning of

Table 2-44 Port 14 Functions (cont'd)

Pin	Symbol	Ctrl.	Buffer Type	Function
151	P14.9	I	LVDS_R X/FAST/ PU1/ VEXT/ ES	General-purpose input
	GTM_TIM3_IN3_3			Mux input channel 3 of TIM module 3
	GTM_TIM2_IN3_3			Mux input channel 3 of TIM module 2
	ASCLIN0_ACTSA			Clear to send input
	QSPI2_MRSTFN			Master SPI data input (LVDS N line)
	ASCLIN9_ARXD			Receive input
	P14.9	O0	General-purpose output	
	GTM_TOUT89	O1	GTM muxed output	
	CAN23_TXD	O2	CAN transmit output node 3	
	MSC0_EN1	O3	Chip Select	
	CAN10_TXD	O4	CAN transmit output node 0	
	ERAY0_TXENB	O5	Transmit Enable Channel B	
	ERAY0_TXENA	O6	Transmit Enable Channel A	
	—	O7	Reserved	
152	P14.10	I	LVDS_R X/FAST/ PU1/ VEXT/ ES	General-purpose input
	GTM_TIM3_IN4_3			Mux input channel 4 of TIM module 3
	GTM_TIM2_IN4_3			Mux input channel 4 of TIM module 2
	CAN23_RXDA			CAN receive input node 3
	QSPI2_MRSTFP			Master SPI data input (LVDS P line)
	P14.10	O0	General-purpose output	
	GTM_TOUT90	O1	GTM muxed output	
	—	O2	Reserved	
	MSC0_EN0	O3	Chip Select	
	ASCLIN1_ATX	O4	Transmit output	
	IOM_MON2_13	O5	Monitor input 2	
	IOM_REF2_13		Reference input 2	
	CAN02_TXD		CAN transmit output node 2	
	IOM_MON2_7	O5	Monitor input 2	
	IOM_REF2_7		Reference input 2	
	ERAY0_TXDA	O6	Transmit Channel A	
	—	O7	Reserved	

TC37xEXT Pin Definition and Functions LQFP-176 Package Pinning of

Table 2-45 Port 15 Functions

Pin	Symbol	Ctrl.	Buffer Type	Function
133	P15.0	I	FAST / PU1 / VEXT / ES	General-purpose input
	GTM_TIM3_IN3_4			Mux input channel 3 of TIM module 3
	GTM_TIM2_IN3_4			Mux input channel 3 of TIM module 2
	SDMMC0_DAT7_IN			read data in
	P15.0	O0		General-purpose output
	GTM_TOUT71	O1		GTM muxed output
	ASCLIN1_ATX	O2		Transmit output
	IOM_MON2_13			Monitor input 2
	IOM_REF2_13			Reference input 2
	QSPI0_SLSO13	O3		Master slave select output
	—	O4		Reserved
	CAN02_TXD	O5		CAN transmit output node 2
	IOM_MON2_7	O6		Monitor input 2
	IOM_REF2_7			Reference input 2
	ASCLIN1_ASCLK			Shift clock output
—	O7	Reserved		
SDMMC0_DAT7	O	write data out		
134	P15.1	I	FAST / PU1 / VEXT / ES	General-purpose input
	GTM_TIM3_IN4_4			Mux input channel 4 of TIM module 3
	GTM_TIM2_IN4_4			Mux input channel 4 of TIM module 2
	CAN02_RXDA			CAN receive input node 2
	ASCLIN1_ARXA			Receive input
	QSPI2_SLSIB			Slave select input
	SCU_E_REQ7_2			ERU Channel 7 inputs 0 to 5 (0 is the LSB and 5 is the MSB)
	P15.1	O0		General-purpose output
	GTM_TOUT72	O1		GTM muxed output
	ASCLIN1_ATX	O2		Transmit output
	IOM_MON2_13			Monitor input 2
	IOM_REF2_13			Reference input 2
	QSPI2_SLSO5	O3		Master slave select output
	—	O4		Reserved
	—	O5		Reserved
—	O6	Reserved		
SDMMC0_CLK	O7	card clock		

TC37xEXT Pin Definition and Functions LQFP-176 Package Pinning of

Table 2-45 Port 15 Functions (cont'd)

Pin	Symbol	Ctrl.	Buffer Type	Function	
135	P15.2	I	FAST / PU1 / VEXT / ES	General-purpose input	
	GTM_TIM3_IN5_4			Mux input channel 5 of TIM module 3	
	GTM_TIM2_IN5_4			Mux input channel 5 of TIM module 2	
	QSPI2_SLSIA			Slave select input	
	SENT_SENT10D			Receive input channel 10	
	QSPI2_MRSTE			Master SPI data input	
	P15.2	O0	FAST / PU1 / VEXT / ES	General-purpose output	
	GTM_TOUT73	O1		GTM muxed output	
	ASCLIN0_ATX	O2		Transmit output	
	IOM_MON2_12			Monitor input 2	
	IOM_REF2_12			Reference input 2	
	QSPI2_SLSO0	O3		Master slave select output	
	—	O4		Reserved	
	CAN01_TXD	O5		CAN transmit output node 1	
	IOM_MON2_6			Monitor input 2	
	IOM_REF2_6			Reference input 2	
	ASCLIN0_ASCLK	O6		Shift clock output	
	—	O7		Reserved	
	136	P15.3		I	FAST / PU1 / VEXT / ES
GTM_TIM3_IN6_4		Mux input channel 6 of TIM module 3			
GTM_TIM2_IN6_4		Mux input channel 6 of TIM module 2			
CAN01_RXDA		CAN receive input node 1			
ASCLIN0_ARXB		Receive input			
QSPI2_SCLKA		Slave SPI clock inputs			
SDMMC0_CMD_IN		command in			
P15.3		O0	FAST / PU1 / VEXT / ES	General-purpose output	
GTM_TOUT74		O1		GTM muxed output	
ASCLIN0_ATX		O2		Transmit output	
IOM_MON2_12				Monitor input 2	
IOM_REF2_12				Reference input 2	
QSPI2_SCLK		O3		Master SPI clock output	
—		O4		Reserved	
MSC0_EN1		O5		Chip Select	
—		O6		Reserved	
—		O7		Reserved	
SDMMC0_CMD		O		command out	

TC37xEXT Pin Definition and Functions LQFP-176 Package Pinning of

Table 2-45 Port 15 Functions (cont'd)

Pin	Symbol	Ctrl.	Buffer Type	Function
137	P15.4	I	FAST / PU1 / VEXT / ES	General-purpose input
	GTM_TIM3_IN7_4			Mux input channel 7 of TIM module 3
	GTM_TIM2_IN7_4			Mux input channel 7 of TIM module 2
	I2C0_SCLC			Serial Clock Input 2
	QSPI2_MRSTA			Master SPI data input
	SCU_E_REQ0_0			ERU Channel 0 inputs 0 to 5 (0 is the LSB and 5 is the MSB)
	SENT_SENT11D			Receive input channel 11
	P15.4			O0
	GTM_TOUT75	O1	GTM muxed output	
	ASCLIN1_ATX	O2	Transmit output	
	IOM_MON2_13		Monitor input 2	
	IOM_REF2_13		Reference input 2	
	QSPI2_MRST	O3	Slave SPI data output	
	IOM_MON2_2		Monitor input 2	
	IOM_REF2_2		Reference input 2	
	—	O4	Reserved	
	—	O5	Reserved	
	I2C0_SCL	O6	Serial Clock Output	
	CCU60_CC62	O7	T12 PWM channel 62	
	IOM_MON1_0		Monitor input 1	
IOM_REF1_4	Reference input 1			

TC37xEXT Pin Definition and Functions LQFP-176 Package Pinning of

Table 2-45 Port 15 Functions (cont'd)

Pin	Symbol	Ctrl.	Buffer Type	Function	
138	P15.5	I	FAST / PU1 / VEXT / ES	General-purpose input	
	GTM_TIM3_IN0_4			Mux input channel 0 of TIM module 3	
	GTM_TIM2_IN0_4			Mux input channel 0 of TIM module 2	
	ASCLIN1_ARXB			Receive input	
	I2C0_SDAC			Serial Data Input 2	
	QSPI2_MTSRA			Slave SPI data input	
	SCU_E_REQ4_3			ERU Channel 4 inputs 0 to 5 (0 is the LSB and 5 is the MSB)	
	P15.5			O0	General-purpose output
	GTM_TOUT76			O1	GTM muxed output
	ASCLIN1_ATX			O2	Transmit output
	IOM_MON2_13				Monitor input 2
	IOM_REF2_13				Reference input 2
	QSPI2_MTSR			O3	Master SPI data output
	—			O4	Reserved
	MSC0_EN0			O5	Chip Select
	I2C0_SDA			O6	Serial Data Output
	CCU60_CC61			O7	T12 PWM channel 61
IOM_MON1_1		Monitor input 1			
IOM_REF1_5		Reference input 1			
139	P15.6	I	FAST / PU1 / VEXT / ES	General-purpose input	
	GTM_TIM2_IN2_14			Mux input channel 2 of TIM module 2	
	GTM_TIM1_IN0_6			Mux input channel 0 of TIM module 1	
	GTM_TIM0_IN0_6			Mux input channel 0 of TIM module 0	
	QSPI2_MTSRB			Slave SPI data input	
	P15.6			O0	General-purpose output
	GTM_TOUT77			O1	GTM muxed output
	ASCLIN3_ATX			O2	Transmit output
	IOM_MON2_15				Monitor input 2
	IOM_REF2_15				Reference input 2
	QSPI2_MTSR			O3	Master SPI data output
	—			O4	Reserved
	QSPI2_SCLK			O5	Master SPI clock output
	ASCLIN3_ASCLK			O6	Shift clock output
	CCU60_CC60			O7	T12 PWM channel 60
IOM_MON1_2		Monitor input 1			
IOM_REF1_6		Reference input 1			

TC37xEXT Pin Definition and Functions LQFP-176 Package Pinning of

Table 2-45 Port 15 Functions (cont'd)

Pin	Symbol	Ctrl.	Buffer Type	Function	
140	P15.7	I	FAST / PU1 / VEXT / ES	General-purpose input	
	GTM_TIM1_IN1_5			Mux input channel 1 of TIM module 1	
	GTM_TIM0_IN1_5			Mux input channel 1 of TIM module 0	
	ASCLIN3_ARXA			Receive input	
	QSPI2_MRSTB			Master SPI data input	
	P15.7			O0	General-purpose output
	GTM_TOUT78			O1	GTM muxed output
	ASCLIN3_ATX			O2	Transmit output
	IOM_MON2_15			O3	Monitor input 2
	IOM_REF2_15				Reference input 2
	QSPI2_MRST				Slave SPI data output
	IOM_MON2_2			Monitor input 2	
	IOM_REF2_2			Reference input 2	
	—			O4	Reserved
	—			O5	Reserved
	—			O6	Reserved
	CCU60_COUT60			O7	T12 PWM channel 60
IOM_MON1_3	Monitor input 1				
IOM_REF1_3	Reference input 1				
141	P15.8	I	FAST / PU1 / VEXT / ES	General-purpose input	
	GTM_TIM1_IN2_5			Mux input channel 2 of TIM module 1	
	GTM_TIM0_IN2_5			Mux input channel 2 of TIM module 0	
	QSPI2_SCLKB			Slave SPI clock inputs	
	SCU_E_REQ5_0			ERU Channel 5 inputs 0 to 5 (0 is the LSB and 5 is the MSB)	
	P15.8			O0	General-purpose output
	GTM_TOUT79			O1	GTM muxed output
	—			O2	Reserved
	QSPI2_SCLK			O3	Master SPI clock output
	—			O4	Reserved
	—			O5	Reserved
	ASCLIN3_ASCLK			O6	Shift clock output
	CCU60_COUT61			O7	T12 PWM channel 61
	IOM_MON1_4				Monitor input 1
IOM_REF1_2	Reference input 1				

TC37xEXT Pin Definition and Functions LQFP-176 Package Pinning of

Table 2-46 Port 20 Functions

Pin	Symbol	Ctrl.	Buffer Type	Function
116	P20.0	I	FAST / PU1 / VEXT / ES	General-purpose input
	GTM_TIM1_IN6_7			Mux input channel 6 of TIM module 1
	GTM_TIM1_IN4_9			Mux input channel 4 of TIM module 1
	GTM_TIM0_IN6_7			Mux input channel 6 of TIM module 0
	CAN03_RXDC			CAN receive input node 3
	CCU_PAD_SYSCCLK			Sysclk input
	CAN21_RXDC			CAN receive input node 1
	CBS_TGI0			Trigger input
	SCU_E_REQ6_0			ERU Channel 6 inputs 0 to 5 (0 is the LSB and 5 is the MSB)
	GPT120_T6EUDA			Count direction control input of core timer T6
	P20.0	O0	General-purpose output	
	GTM_TOUT59	O1	GTM muxed output	
	ASCLIN3_ATX	O2	Transmit output	
	IOM_MON2_15		Monitor input 2	
	IOM_REF2_15		Reference input 2	
	ASCLIN3_ASCLK	O3	Shift clock output	
	—	O4	Reserved	
	HSCT0_SYSCCLK_OUT	O5	sys clock output	
	—	O6	Reserved	
	—	O7	Reserved	
CBS_TGO0	O	Trigger output		
117	P20.1	I	SLOW / PU1 / VEXT / ES	General-purpose input
	GTM_TIM4_IN4_11			Mux input channel 4 of TIM module 4
	GTM_TIM3_IN3_5			Mux input channel 3 of TIM module 3
	GTM_TIM2_IN3_5			Mux input channel 3 of TIM module 2
	CBS_TGI1			Trigger input
	GTM_DTMA1_1			CDTM1_DTM4
	P20.1	O0	General-purpose output	
	GTM_TOUT60	O1	GTM muxed output	
	—	O2	Reserved	
	—	O3	Reserved	
	—	O4	Reserved	
	—	O5	Reserved	
	—	O6	Reserved	
	—	O7	Reserved	
CBS_TGO1	O	Trigger output		

TC37xEXT Pin Definition and Functions LQFP-176 Package Pinning of

Table 2-46 Port 20 Functions (cont'd)

Pin	Symbol	Ctrl.	Buffer Type	Function
118	P20.2	I	S / PU / VEXT	General-purpose input This pin is latched at power on reset release to enter test mode.
	$\overline{\text{TESTMODE}}$			Testmode Enable Input
119	P20.3	I	SLOW / PU1 / VEXT / ES	General-purpose input
	GTM_TIM4_IN5_11			Mux input channel 5 of TIM module 4
	GTM_TIM3_IN4_5			Mux input channel 4 of TIM module 3
	GTM_TIM2_IN4_5			Mux input channel 4 of TIM module 2
	ASCLIN3_ARXC			Receive input
	GPT120_T6INA			Trigger/gate input of core timer T6
	P20.3	O0		General-purpose output
	GTM_TOUT61	O1		GTM muxed output
	ASCLIN3_ATX	O2		Transmit output
	IOM_MON2_15			Monitor input 2
	IOM_REF2_15			Reference input 2
	QSPI0_SLSO9	O3		Master slave select output
	QSPI2_SLSO9	O4		Master slave select output
	CAN03_TXD	O5		CAN transmit output node 3
	IOM_MON2_8			Monitor input 2
	IOM_REF2_8			Reference input 2
	CAN21_TXD	O6		CAN transmit output node 1
—	O7	Reserved		
124	P20.6	I	SLOW / PU1 / VEXT / ES	General-purpose input
	GTM_TIM3_IN6_5			Mux input channel 6 of TIM module 3
	GTM_TIM2_IN6_5			Mux input channel 6 of TIM module 2
	CAN12_RXDA			CAN receive input node 2
	ASCLIN9_ARXE			Receive input
	P20.6	O0		General-purpose output
	GTM_TOUT62	O1		GTM muxed output
	ASCLIN1_ARTS	O2		Ready to send output
	QSPI0_SLSO8	O3		Master slave select output
	QSPI2_SLSO8	O4		Master slave select output
	—	O5		Reserved
	—	O6		Reserved
	—	O7		Reserved

TC37xEXT Pin Definition and Functions LQFP-176 Package Pinning of

Table 2-46 Port 20 Functions (cont'd)

Pin	Symbol	Ctrl.	Buffer Type	Function
125	P20.7	I	FAST / PU1 / VEXT / ES	General-purpose input
	GTM_TIM3_IN7_5			Mux input channel 7 of TIM module 3
	GTM_TIM2_IN7_5			Mux input channel 7 of TIM module 2
	GTM_TIM1_IN5_8			Mux input channel 5 of TIM module 1
	CAN00_RXDB			CAN receive input node 0
	ASCLIN1_ACTSA			Clear to send input
	ASCLIN9_ARXF			Receive input
	SDMMC0_DAT0_IN			read data in
	P20.7			O0
	GTM_TOUT63	O1	GTM muxed output	
	ASCLIN9_ATX	O2	Transmit output	
	—	O3	Reserved	
	—	O4	Reserved	
	CAN12_TXD	O5	CAN transmit output node 2	
	—	O6	Reserved	
	CCU61_COUT63	O7	T13 PWM channel 63	
	IOM_MON1_7	O	Monitor input 1	
	IOM_REF1_7		Reference input 1	
	SDMMC0_DAT0	O	write data out	
126	P20.8	I	FAST / PU1 / VEXT / ES	General-purpose input
	GTM_TIM1_IN7_3			Mux input channel 7 of TIM module 1
	GTM_TIM0_IN7_3			Mux input channel 7 of TIM module 0
	SDMMC0_DAT1_IN			read data in
	P20.8	O0	General-purpose output	
	GTM_TOUT64	O1	GTM muxed output	
	ASCLIN1_ASLSO	O2	Slave select signal output	
	QSPI0_SLSO0	O3	Master slave select output	
	QSPI1_SLSO0	O4	Master slave select output	
	CAN00_TXD	O5	CAN transmit output node 0	
	IOM_MON2_5	O	Monitor input 2	
	IOM_REF2_5		Reference input 2	
	—		Reserved	
	CCU61_CC60	O7	T12 PWM channel 60	
	IOM_MON1_8	O	Monitor input 1	
	IOM_REF1_13		Reference input 1	
	SDMMC0_DAT1	O	write data out	

TC37xEXT Pin Definition and Functions LQFP-176 Package Pinning of

Table 2-46 Port 20 Functions (cont'd)

Pin	Symbol	Ctrl.	Buffer Type	Function
127	P20.9	I	FAST / PU1 / VEXT / ES	General-purpose input
	GTM_TIM3_IN5_5			Mux input channel 5 of TIM module 3
	GTM_TIM2_IN5_5			Mux input channel 5 of TIM module 2
	CAN03_RXDE			CAN receive input node 3
	ASCLIN1_ARXC			Receive input
	QSPIO_SLSIB			Slave select input
	SCU_E_REQ7_0			ERU Channel 7 inputs 0 to 5 (0 is the LSB and 5 is the MSB)
	P20.9	O0	General-purpose output	
	GTM_TOUT65	O1	GTM muxed output	
	—	O2	Reserved	
	QSPIO_SLSO1	O3	Master slave select output	
	QSPI1_SLSO1	O4	Master slave select output	
	—	O5	Reserved	
	—	O6	Reserved	
	CCU61_CC61	O7	T12 PWM channel 61	
	IOM_MON1_9		Monitor input 1	
IOM_REF1_12		Reference input 1		
128	P20.10	I	FAST / PU1 / VEXT / ES	General-purpose input
	GTM_TIM3_IN6_6			Mux input channel 6 of TIM module 3
	GTM_TIM2_IN6_6			Mux input channel 6 of TIM module 2
	SDMMC0_DAT2_IN			read data in
	P20.10	O0	General-purpose output	
	GTM_TOUT66	O1	GTM muxed output	
	ASCLIN1_ATX	O2	Transmit output	
	IOM_MON2_13		Monitor input 2	
	IOM_REF2_13		Reference input 2	
	QSPIO_SLSO6	O3	Master slave select output	
	QSPI2_SLSO7	O4	Master slave select output	
	CAN03_TXD	O5	CAN transmit output node 3	
	IOM_MON2_8		Monitor input 2	
	IOM_REF2_8		Reference input 2	
	ASCLIN1_ASCLK	O6	Shift clock output	
	CCU61_CC62	O7	T12 PWM channel 62	
	IOM_MON1_10		Monitor input 1	
	IOM_REF1_11		Reference input 1	
SDMMC0_DAT2	O	write data out		

TC37xEXT Pin Definition and Functions LQFP-176 Package Pinning of

Table 2-46 Port 20 Functions (cont'd)

Pin	Symbol	Ctrl.	Buffer Type	Function
129	P20.11	I	FAST / PU1 / VEXT / ES	General-purpose input
	GTM_TIM3_IN7_6			Mux input channel 7 of TIM module 3
	GTM_TIM2_IN7_6			Mux input channel 7 of TIM module 2
	QSPIO_SCLKA			Slave SPI clock inputs
	SDMMC0_DAT3_IN			read data in
	P20.11	O0		General-purpose output
	GTM_TOUT67	O1		GTM muxed output
	—	O2		Reserved
	QSPIO_SCLK	O3		Master SPI clock output
	—	O4		Reserved
	—	O5		Reserved
	—	O6		Reserved
	CCU61_COUT60	O7		T12 PWM channel 60
	IOM_MON1_11			Monitor input 1
	IOM_REF1_10			Reference input 1
SDMMC0_DAT3	O	write data out		
130	P20.12	I	FAST / PU1 / VEXT / ES	General-purpose input
	GTM_TIM3_IN0_5			Mux input channel 0 of TIM module 3
	GTM_TIM2_IN0_5			Mux input channel 0 of TIM module 2
	QSPIO_MRSTA			Master SPI data input
	SDMMC0_DAT4_IN			read data in
	IOM_PIN_13	GPIO pad input to FPC		
	P20.12	O0		General-purpose output
	GTM_TOUT68	O1		GTM muxed output
	IOM_MON0_13	O2		Monitor input 0
	—			Reserved
	QSPIO_MRST			Slave SPI data output
	IOM_MON2_0	O3		Monitor input 2
	IOM_REF2_0			Reference input 2
	QSPIO_MTSR	O4		Master SPI data output
	—	O5		Reserved
	—	O6		Reserved
	CCU61_COUT61	O7		T12 PWM channel 61
	IOM_MON1_12			Monitor input 1
IOM_REF1_9	Reference input 1			
SDMMC0_DAT4	O	write data out		

TC37xEXT Pin Definition and Functions LQFP-176 Package Pinning of

Table 2-46 Port 20 Functions (cont'd)

Pin	Symbol	Ctrl.	Buffer Type	Function
131	P20.13	I	FAST / PU1 / VEXT / ES	General-purpose input
	GTM_TIM3_IN1_4			Mux input channel 1 of TIM module 3
	GTM_TIM2_IN1_4			Mux input channel 1 of TIM module 2
	QSPIO_SLSIA			Slave select input
	SDMMC0_DAT5_IN			read data in
	IOM_PIN_14			GPIO pad input to FPC
	P20.13			O0
	GTM_TOUT69	O1	GTM muxed output	
	IOM_MON0_14	O2	Monitor input 0	
	—		Reserved	
	QSPIO_SLSO2		Master slave select output	
	QSPIO_SLSO2	O4	Master slave select output	
	QSPIO_SCLK	O5	Master SPI clock output	
	—	O6	Reserved	
	CCU61_COUT62	O7	T12 PWM channel 62	
	IOM_MON1_13	O	Monitor input 1	
	IOM_REF1_8		Reference input 1	
	SDMMC0_DAT5		write data out	
	132	P20.14	I	FAST / PU1 / VEXT / ES
GTM_TIM3_IN2_4		Mux input channel 2 of TIM module 3		
GTM_TIM2_IN2_4		Mux input channel 2 of TIM module 2		
QSPIO_MTSRA		Slave SPI data input		
SDMMC0_DAT6_IN		read data in		
IOM_PIN_15		GPIO pad input to FPC		
DMU_FDEST		Enter destructive debug mode		
P20.14		O0	General-purpose output	
GTM_TOUT70		O1	GTM muxed output	
IOM_MON0_15		O2	Monitor input 0	
—			Reserved	
QSPIO_MTSR			Master SPI data output	
—		O4	Reserved	
—		O5	Reserved	
—		O6	Reserved	
—		O7	Reserved	
SDMMC0_DAT6		O	write data out	

TC37xEXT Pin Definition and Functions LQFP-176 Package Pinning of

Table 2-47 Port 21 Functions

Pin	Symbol	Ctrl.	Buffer Type	Function
105	P21.0	I	LVDS_R X/FAST/ PU1/ VEXT/ ES	General-purpose input
	GTM_TIM4_IN0_11			Mux input channel 0 of TIM module 4
	GTM_TIM3_IN4_6			Mux input channel 4 of TIM module 3
	GTM_TIM2_IN4_6			Mux input channel 4 of TIM module 2
	QSPI4_MRSTDN			Master SPI data input (LVDS N line)
	ASCLIN11_ARXC			Receive input
	P21.0	O0		General-purpose output
	GTM_TOUT51	O1		GTM muxed output
	ASCLIN11_ATX	O2		Transmit output
	—	O3		Reserved
	—	O4		Reserved
	—	O5		Reserved
	GETH1_PPS	O6		Pulse Per Second
	—	O7		Reserved
HSM_HSM1	O	Pin Output Value		
106	P21.1	I	LVDS_R X/FAST/ PU1/ VEXT/ ES	General-purpose input
	GTM_TIM4_IN1_13			Mux input channel 1 of TIM module 4
	GTM_TIM3_IN5_6			Mux input channel 5 of TIM module 3
	GTM_TIM2_IN5_6			Mux input channel 5 of TIM module 2
	QSPI4_MRSTDTP			Master SPI data input (LVDS P line)
	ASCLIN11_ARXD			Receive input
	GTM_DTMA4_1			CDTM4_DTM4
	P21.1	O0		General-purpose output
	GTM_TOUT52	O1		GTM muxed output
	—	O2		Reserved
	—	O3		Reserved
	—	O4		Reserved
	—	O5		Reserved
	—	O6		Reserved
—	O7	Reserved		
HSM_HSM2	O	Pin Output Value		

TC37xEXT Pin Definition and Functions LQFP-176 Package Pinning of

Table 2-47 Port 21 Functions (cont'd)

Pin	Symbol	Ctrl.	Buffer Type	Function	
107	P21.2	I	LVDS_R X/FAST/ PU1/ VEXT/ ES	General-purpose input	
	GTM_TIM5_IN4_11			Mux input channel 4 of TIM module 5	
	GTM_TIM1_IN0_7			Mux input channel 0 of TIM module 1	
	GTM_TIM0_IN0_7			Mux input channel 0 of TIM module 0	
	QSPI2_MRSTCN			Master SPI data input (LVDS N line)	
	SCU_EMGSTOP_POR T_B			Emergency stop Port Pin B input request	
	ASCLIN3_ARXGN			Differential Receive input (low active)	
	HSCT0_RXDN			Rx data	
	QSPI4_MRSTCN			Master SPI data input (LVDS N line)	
	ASCLIN11_ARXE			Receive input	
	GTM_DTMA1_0			CDTM1_DTM4	
	P21.2	O0	General-purpose output		
	GTM_TOUT53	O1	GTM muxed output		
	ASCLIN3_ASLSO	O2	Slave select signal output		
	—	O3	Reserved		
	—	O4	Reserved		
	GETH_MDC	O5	MDIO clock		
—	O6	Reserved			
—	O7	Reserved			
108	P21.3	I	LVDS_R X/FAST/ PU1/ VEXT/ ES	General-purpose input	
	GTM_TIM5_IN5_12			Mux input channel 5 of TIM module 5	
	GTM_TIM1_IN1_6			Mux input channel 1 of TIM module 1	
	GTM_TIM0_IN1_6			Mux input channel 1 of TIM module 0	
	QSPI2_MRSTCP			Master SPI data input (LVDS P line)	
	ASCLIN3_ARXGP			Differential Receive input (high active)	
	GETH_MDIOD			MDIO Input	
	HSCT0_RXDP			Rx data	
	QSPI4_MRSTCP			Master SPI data input (LVDS P line)	
	P21.3			O0	General-purpose output
	GTM_TOUT54			O1	GTM muxed output
	ASCLIN11_ASCLK	O2	Shift clock output		
	—	O3	Reserved		
	—	O4	Reserved		
	—	O5	Reserved		
	—	O6	Reserved		
	—	O7	Reserved		
GETH_MDIO	O	MDIO Output			

TC37xEXT Pin Definition and Functions LQFP-176 Package Pinning of

Table 2-47 Port 21 Functions (cont'd)

Pin	Symbol	Ctrl.	Buffer Type	Function
109	P21.4	I	LVDS_TX / FAST / PU1 / VEXT / ES6	General-purpose input
	GTM_TIM5_IN6_12			Mux input channel 6 of TIM module 5
	GTM_TIM1_IN2_6			Mux input channel 2 of TIM module 1
	GTM_TIM0_IN2_6			Mux input channel 2 of TIM module 0
	P21.4	O0		General-purpose output
	GTM_TOUT55	O1		GTM muxed output
	ASCLIN11_ASLSO	O2		Slave select signal output
	—	O3		Reserved
	—	O4		Reserved
	—	O5		Reserved
	—	O6		Reserved
	—	O7		Reserved
	H SCT0_TXDN	O		Tx data
110	P21.5	I	LVDS_TX / FAST / PU1 / VEXT / ES6	General-purpose input
	GTM_TIM5_IN7_11			Mux input channel 7 of TIM module 5
	GTM_TIM1_IN3_6			Mux input channel 3 of TIM module 1
	GTM_TIM0_IN3_6			Mux input channel 3 of TIM module 0
	ASCLIN11_ARXF			Receive input
	P21.5	O0		General-purpose output
	GTM_TOUT56	O1		GTM muxed output
	ASCLIN3_ASCLK	O2		Shift clock output
	ASCLIN11_ATX	O3		Transmit output
	—	O4		Reserved
	—	O5		Reserved
	—	O6		Reserved
	—	O7		Reserved
H SCT0_TXDP	O	Tx data		

TC37xEXT Pin Definition and Functions LQFP-176 Package Pinning of

Table 2-47 Port 21 Functions (cont'd)

Pin	Symbol	Ctrl.	Buffer Type	Function
111	P21.6/TDI	I	FAST / PD / PU2 / VEXT / ES3	General-purpose input PD during Reset and in DAP/DAPE or JTAG mode. After Reset release and when not in DAP/DAPE or JTAG mode: PU. In Standby mode: HighZ. DAPE: DAPE1 Data I/O.
	GTM_TIM4_IN2_12			Mux input channel 2 of TIM module 4
	GTM_TIM1_IN4_8			Mux input channel 4 of TIM module 1
	GTM_TIM0_IN4_8			Mux input channel 4 of TIM module 0
	GPT120_T5EUDA			Count direction control input of timer T5
	ASCLIN3_ARXF			Receive input
	CBS_TGI2			Trigger input
	TDI			JTAG Module Data Input
	P21.6	O0	General-purpose output	
	GTM_TOUT57	O1	GTM muxed output	
	ASCLIN3_ASLSO	O2	Slave select signal output	
	—	O3	Reserved	
	—	O4	Reserved	
	—	O5	Reserved	
	—	O6	Reserved	
	GPT120_T3OUT	O7	External output for overflow/underflow detection of core timer T3	
	CBS_TGO2	O	Trigger output	
	DAP3	I/O	DAP: DAP3 Data I/O	
	DAPE1	I/O	DAPE: DAPE1 Data I/O	

TC37xEXT Pin Definition and Functions LQFP-176 Package Pinning of

Table 2-47 Port 21 Functions (cont'd)

Pin	Symbol	Ctrl.	Buffer Type	Function	
113	P21.7/TDO	I	FAST / PU2 / VEXT / ES4	General-purpose input DAP: DAP2 Data I/O; DAPE: DAPE2 Data I/O.	
	GTM_TIM4_IN3_12			Mux input channel 3 of TIM module 4	
	GTM_TIM1_IN5_7			Mux input channel 5 of TIM module 1	
	GTM_TIM0_IN5_7			Mux input channel 5 of TIM module 0	
	GPT120_T5INA			Trigger/gate input of timer T5	
	CBS_TGI3			Trigger input	
	GETH_RXERB			Receive Error MII	
	P21.7			O0	General-purpose output
	GTM_TOUT58			O1	GTM muxed output
	ASCLIN3_ATX			O2	Transmit output
	IOM_MON2_15				Monitor input 2
	IOM_REF2_15				Reference input 2
	ASCLIN3_ASCLK			O3	Shift clock output
	—	O4	Reserved		
	—	O5	Reserved		
	—	O6	Reserved		
	GPT120_T6OUT	O7	External output for overflow/underflow detection of core timer T6		
	CBS_TGO3	O	Trigger output		
	DAP2	I/O	DAP: DAP2 Data I/O		
	DAPE2	I/O	DAPE: DAPE2 Data I/O		
TDO	O	JTAG Module Data Output			

TC37xEXT Pin Definition and Functions LQFP-176 Package Pinning of

Table 2-48 Port 22 Functions

Pin	Symbol	Ctrl.	Buffer Type	Function	
95	P22.0	I	LVDS_TX / FAST / PU1 / VFLEX2 / ES6	General-purpose input	
	GTM_TIM1_IN1_7			Mux input channel 1 of TIM module 1	
	GTM_TIM0_IN1_7			Mux input channel 1 of TIM module 0	
	QSPI4_MTSRB			Slave SPI data input	
	ASCLIN6_ARXE			Receive input	
	GETH1_CRSDVB			Carrier Sense / Data Valid combi-signal for RMII	
	GETH1_RXDVB			Receive Data Valid MII	
	GETH1_CRSA			Carrier Sense MII	
	P22.0			O0	General-purpose output
	GTM_TOUT47	O1	GTM muxed output		
	ASCLIN3_ATXN	O2	Differential Transmit output (low active)		
	QSPI4_MTSR	O3	Master SPI data output		
	QSPI4_SCLKN	O4	Master SPI clock output (LVDS N line)		
	MSC1_FCLN	O5	Shift-clock inverted part of the differential signal		
	—	O6	Reserved		
	ASCLIN6_ATX	O7	Transmit output		
96	P22.1	I	LVDS_TX / FAST / PU1 / VFLEX2 / ES6	General-purpose input	
	GTM_TIM1_IN0_8			Mux input channel 0 of TIM module 1	
	GTM_TIM0_IN0_8			Mux input channel 0 of TIM module 0	
	QSPI4_MRSTB			Master SPI data input	
	ASCLIN7_ARXE			Receive input	
	GETH1_RXERA			Receive Error MII	
	P22.1			O0	General-purpose output
	GTM_TOUT48			O1	GTM muxed output
	ASCLIN3_ATXP			O2	Differential Transmit output (high active)
	QSPI4_MRST	O3	Slave SPI data output		
	IOM_MON2_4		Monitor input 2		
	IOM_REF2_4		Reference input 2		
	QSPI4_SCLKP	O4	Master SPI clock output (LVDS P line)		
	MSC1_FCLP	O5	Shift-clock direct part of the differential signal		
	—	O6	Reserved		
	ASCLIN7_ATX	O7	Transmit output		

TC37xEXT Pin Definition and Functions LQFP-176 Package Pinning of

Table 2-48 Port 22 Functions (cont'd)

Pin	Symbol	Ctrl.	Buffer Type	Function
97	P22.2	I	LVDS_TX / FAST / PU1 / VEXT / ES6	General-purpose input
	GTM_TIM1_IN3_7			Mux input channel 3 of TIM module 1
	GTM_TIM0_IN3_7			Mux input channel 3 of TIM module 0
	QSPI4_SLSIB			Slave select input
	GETH1_COLA			Collision MII
	P22.2	O0	General-purpose output	
	GTM_TOUT49	O1	GTM muxed output	
	ASCLIN5_ATX	O2	Transmit output	
	QSPI4_SLSO3	O3	Master slave select output	
	QSPI4_MTSRN	O4	Master SPI data output (LVDS N line)	
	MSC1_SON	O5	Data output - inverted part of the differential signal	
	—	O6	Reserved	
	—	O7	Reserved	
98	P22.3	I	LVDS_TX / FAST / PU1 / VEXT / ES6	General-purpose input
	GTM_TIM1_IN4_4			Mux input channel 4 of TIM module 1
	GTM_TIM0_IN4_4			Mux input channel 4 of TIM module 0
	QSPI4_SCLKB			Slave SPI clock inputs
	ASCLIN5_ARXC			Receive input
	P22.3	O0	General-purpose output	
	GTM_TOUT50	O1	GTM muxed output	
	—	O2	Reserved	
	QSPI4_SCLK	O3	Master SPI clock output	
	QSPI4_MTSRP	O4	Master SPI data output (LVDS P line)	
	MSC1_SOP	O5	Data output - direct part of the differential signal	
	—	O6	Reserved	
	—	O7	Reserved	

TC37xEXT Pin Definition and Functions LQFP-176 Package Pinning of

Table 2-49 Port 23 Functions

Pin	Symbol	Ctrl.	Buffer Type	Function
89	P23.0	I	SLOW / PU1 / VEXT / ES	General-purpose input
	GTM_TIM1_IN5_4			Mux input channel 5 of TIM module 1
	GTM_TIM0_IN5_4			Mux input channel 5 of TIM module 0
	CAN10_RXDC			CAN receive input node 0
	P23.0	O0		General-purpose output
	GTM_TOUT41	O1		GTM muxed output
	—	O2		Reserved
	—	O3		Reserved
	—	O4		Reserved
	—	O5		Reserved
	—	O6		Reserved
—	O7	Reserved		
90	P23.1	I	FAST / PU1 / VEXT / ES	General-purpose input
	GTM_TIM1_IN6_4			Mux input channel 6 of TIM module 1
	GTM_TIM0_IN6_4			Mux input channel 6 of TIM module 0
	MSC1_SDI0			Upstream asynchronous input signal
	ASCLIN6_ARXF			Receive input
	P23.1	O0		General-purpose output
	GTM_TOUT42	O1		GTM muxed output
	ASCLIN1_ARTS	O2		Ready to send output
	QSPI4_SLSO6	O3		Master slave select output
	GTM_CLK0	O4		CGM generated clock
	CAN10_TXD	O5		CAN transmit output node 0
	CCU_EXTCLK0	O6		External Clock 0
	ASCLIN6_ASCLK	O7		Shift clock output
91	P23.2	I	RFAST / PU1 / VFLEX2 / ES	General-purpose input
	GTM_TIM1_IN6_5			Mux input channel 6 of TIM module 1
	GTM_TIM0_IN6_5			Mux input channel 6 of TIM module 0
	ASCLIN7_ARXC			Receive input
	P23.2	O0		General-purpose output
	GTM_TOUT43	O1		GTM muxed output
	—	O2		Reserved
	—	O3		Reserved
	CAN23_TXD	O4		CAN transmit output node 3
	CAN12_TXD	O5		CAN transmit output node 2
	GETH1_TXD3	O6		Transmit Data
	—	O7		Reserved

TC37xEXT Pin Definition and Functions LQFP-176 Package Pinning of

Table 2-49 Port 23 Functions (cont'd)

Pin	Symbol	Ctrl.	Buffer Type	Function
92	P23.3	I	RFAST / PU1 / VFLEX2 / ES	General-purpose input
	GTM_TIM1_IN7_4			Mux input channel 7 of TIM module 1
	GTM_TIM0_IN7_4			Mux input channel 7 of TIM module 0
	MSC1_INJ0			Injection signal from port
	ASCLIN6_ARXA			Receive input
	CAN12_RXDC			CAN receive input node 2
	CAN23_RXDB			CAN receive input node 3
	P23.3			O0
	GTM_TOUT44	O1	GTM muxed output	
	ASCLIN7_ATX	O2	Transmit output	
	—	O3	Reserved	
	—	O4	Reserved	
	—	O5	Reserved	
	GETH1_TXD2	O6	Transmit Data	
—	O7	Reserved		
93	P23.4	I	RFAST / PU1 / VFLEX2 / ES	General-purpose input
	GTM_TIM1_IN7_5			Mux input channel 7 of TIM module 1
	GTM_TIM0_IN7_5			Mux input channel 7 of TIM module 0
	P23.4	O0	General-purpose output	
	GTM_TOUT45	O1	GTM muxed output	
	ASCLIN6_ASLSO	O2	Slave select signal output	
	QSPI4_SLSO5	O3	Master slave select output	
	—	O4	Reserved	
	MSC1_EN0	O5	Chip Select	
	GETH1_TXD1	O6	Transmit Data	
	—	O7	Reserved	

TC37xEXT Pin Definition and Functions LQFP-176 Package Pinning of

Table 2-49 Port 23 Functions (cont'd)

Pin	Symbol	Ctrl.	Buffer Type	Function
94	P23.5	I	FAST / RGMII_Input / PU1 / VFLEX2 / ES	General-purpose input
	GTM_TIM1_IN2_7			Mux input channel 2 of TIM module 1
	GTM_TIM0_IN2_7			Mux input channel 2 of TIM module 0
	GETH1_RXD3A			Receive Data 3 MII and RGMII (RGMII can use RXD3A only)
	P23.5	O0		General-purpose output
	GTM_TOUT46	O1		GTM muxed output
	ASCLIN6_ATX	O2		Transmit output
	QSPI4_SLSO4	O3		Master slave select output
	—	O4		Reserved
	MSC1_EN1	O5		Chip Select
	CAN22_TXD	O6		CAN transmit output node 2
	—	O7		Reserved

Table 2-50 Port 32 Functions

Pin	Symbol	Ctrl.	Buffer Type	Function
84	P32.0	I	SLOW / PU1 / VEXT / ES	General-purpose input P32.0 / SMPS mode: analog output. External Pass Device gate control for EVRC
	GTM_TIM3_IN2_5			Mux input channel 2 of TIM module 3
	GTM_TIM2_IN2_5			Mux input channel 2 of TIM module 2
	P32.0	O0		General-purpose output
	GTM_TOUT36	O1		GTM muxed output
	—	O2		Reserved
	—	O3		Reserved
	—	O4		Reserved
	—	O5		Reserved
	—	O6		Reserved
	—	O7		Reserved

TC37xEXT Pin Definition and Functions LQFP-176 Package Pinning of

Table 2-50 Port 32 Functions (cont'd)

Pin	Symbol	Ctrl.	Buffer Type	Function
85	P32.1	I	SLOW / PU1 / VEXT / ES	General-purpose input P32.1 / External Pass Device gate control for EVRC
	GTM_TIM3_IN3_15			Mux input channel 3 of TIM module 3
	P32.1	O0		General-purpose output
	GTM_TOUT37	O1		GTM muxed output
	—	O2		Reserved
	—	O3		Reserved
	—	O4		Reserved
	—	O5		Reserved
	—	O6		Reserved
	—	O7		Reserved
86	P32.2	I	SLOW / PU1 / VEXT / ES	General-purpose input
	GTM_TIM1_IN3_8			Mux input channel 3 of TIM module 1
	GTM_TIM0_IN3_8			Mux input channel 3 of TIM module 0
	CAN03_RXDB			CAN receive input node 3
	ASCLIN3_ARXD			Receive input
	CAN21_RXDD			CAN receive input node 1
	P32.2			O0
	GTM_TOUT38	O1		GTM muxed output
	ASCLIN3_ATX	O2		Transmit output
	IOM_MON2_15			Monitor input 2
	IOM_REF2_15			Reference input 2
	—			O3
	—	O4		Reserved
	—	O5		Reserved
	PMS_DCDCSYNCO	O6		DC-DC synchronization output
—	O7	Reserved		

TC37xEXT Pin Definition and Functions LQFP-176 Package Pinning of

Table 2-50 Port 32 Functions (cont'd)

Pin	Symbol	Ctrl.	Buffer Type	Function
87	P32.3	I	SLOW / PU1 / VEXT / ES	General-purpose input
	GTM_TIM1_IN4_5			Mux input channel 4 of TIM module 1
	GTM_TIM0_IN4_5			Mux input channel 4 of TIM module 0
	P32.3	O0		General-purpose output
	GTM_TOUT39	O1		GTM muxed output
	ASCLIN3_ATX	O2		Transmit output
	IOM_MON2_15			Monitor input 2
	IOM_REF2_15	O3		Reference input 2
	—			Reserved
	ASCLIN3_ASCLK			O4
	CAN03_TXD	O5		CAN transmit output node 3
	IOM_MON2_8	O6		Monitor input 2
	IOM_REF2_8			Reference input 2
	CAN21_TXD	O6		CAN transmit output node 1
	—	O7		Reserved
88	P32.4	I	FAST / PU1 / VEXT / ES	General-purpose input
	GTM_TIM1_IN5_5			Mux input channel 5 of TIM module 1
	GTM_TIM0_IN5_5			Mux input channel 5 of TIM module 0
	ASCLIN1_ACTSB			Clear to send input
	MSC1_SDI2			Upstream asynchronous input signal
	P32.4	O0		General-purpose output
	GTM_TOUT40	O1		GTM muxed output
	—	O2		Reserved
	—	O3		Reserved
	GTM_CLK1	O4		CGM generated clock
	MSC1_EN0	O5		Chip Select
	CCU_EXTCLK1	O6		External Clock 1
	CCU60_COUT63	O7		T13 PWM channel 63
	IOM_MON1_6			Monitor input 1
	IOM_REF1_0	O		Reference input 1
PMS_DCDCSYNCO	DC-DC synchronization output			

TC37xEXT Pin Definition and Functions LQFP-176 Package Pinning of

Table 2-51 Port 33 Functions

Pin	Symbol	Ctrl.	Buffer Type	Function
70	P33.0	I	SLOW / PU1 / VEVRSB / ES5	General-purpose input
	GTM_TIM3_IN0_13			Mux input channel 0 of TIM module 3
	GTM_TIM1_IN4_6			Mux input channel 4 of TIM module 1
	GTM_TIM0_IN4_6			Mux input channel 4 of TIM module 0
	EDSADC_ITR0E			Trigger/Gate input, channel 0
	SENT_SENT13C			Receive input channel 13
	IOM_PIN_0			GPIO pad input to FPC
	GTM_DTMT1_2			CDTM1_DTM0
	EVADC_G10CH7			AI
	P33.0	O0	General-purpose output	
	GTM_TOUT22	O1	GTM muxed output	
	IOM_MON0_0		Monitor input 0	
	IOM_GTM_0		GTM-provided inputs to EXOR combiner	
	ASCLIN5_ATX	O2	Transmit output	
	—	O3	Reserved	
	—	O4	Reserved	
	—	O5	Reserved	
	EVADC_FC2BFLOUT	O6	Boundary flag output, FC channel 2	
	—	O7	Reserved	

TC37xEXT Pin Definition and Functions LQFP-176 Package Pinning of

Table 2-51 Port 33 Functions (cont'd)

Pin	Symbol	Ctrl.	Buffer Type	Function
71	P33.1	I	SLOW / PU1 / VEVRSB / ES5	General-purpose input
	GTM_TIM3_IN1_15			Mux input channel 1 of TIM module 3
	GTM_TIM1_IN5_6			Mux input channel 5 of TIM module 1
	GTM_TIM0_IN5_6			Mux input channel 5 of TIM module 0
	EDSADC_ITR1E			Trigger/Gate input, channel 1
	PSI5_RX0C			RXD inputs (receive data) channel 0
	EDSADC_DSCIN2B			Modulator clock input, channel 2
	SENT_SENT9C			Receive input channel 9
	ASCLIN8_ARXC			Receive input
	IOM_PIN_1			GPIO pad input to FPC
	EVADC_G10CH6	AI	Analog input channel 6, group 10	
	P33.1	O0	General-purpose output	
	GTM_TOUT23	O1	GTM muxed output	
	IOM_MON0_1		Monitor input 0	
	IOM_GTM_1	O2	GTM-provided inputs to EXOR combiner	
	ASCLIN3_ASLSO		Slave select signal output	
	QSPI2_SCLK	O3	Master SPI clock output	
	EDSADC_DSCOUT2	O4	Modulator clock output	
	EVADC_EMUX02	O5	Control of external analog multiplexer interface 0	
	—	O6	Reserved	
—	O7	Reserved		

TC37xEXT Pin Definition and Functions LQFP-176 Package Pinning of

Table 2-51 Port 33 Functions (cont'd)

Pin	Symbol	Ctrl.	Buffer Type	Function
72	P33.2	I	SLOW / PU1 / VEVRSB / ES5	General-purpose input
	GTM_TIM3_IN2_14			Mux input channel 2 of TIM module 3
	GTM_TIM1_IN6_6			Mux input channel 6 of TIM module 1
	GTM_TIM0_IN6_6			Mux input channel 6 of TIM module 0
	EDSADC_ITR2E			Trigger/Gate input, channel 2
	SENT_SENT8C			Receive input channel 8
	EDSADC_DSDIN2B			Digital datastream input, channel 2
	IOM_PIN_2			GPIO pad input to FPC
	EVADC_G10CH5			AI
	P33.2	O0	General-purpose output	
	GTM_TOUT24	O1	GTM muxed output	
	IOM_MON0_2		Monitor input 0	
	IOM_GTM_2		GTM-provided inputs to EXOR combiner	
	ASCLIN3_ASCLK		O2	Shift clock output
	QSPI2_SLSO10	O3	Master slave select output	
	PSI5_TX0	O4	TXD outputs (send data)	
	IOM_MON1_14		Monitor input 1	
	IOM_REF1_14		Reference input 1	
	EVADC_EMUX01	O5	Control of external analog multiplexer interface 0	
	EVADC_FC3BFLOUT	O6	Boundary flag output, FC channel 3	
—	O7	Reserved		

TC37xEXT Pin Definition and Functions LQFP-176 Package Pinning of

Table 2-51 Port 33 Functions (cont'd)

Pin	Symbol	Ctrl.	Buffer Type	Function
73	P33.3	I	SLOW / PU1 / VEVRSB / ES5	General-purpose input
	GTM_TIM3_IN3_12			Mux input channel 3 of TIM module 3
	GTM_TIM1_IN7_6			Mux input channel 7 of TIM module 1
	GTM_TIM0_IN7_6			Mux input channel 7 of TIM module 0
	PSI5_RX1C			RXD inputs (receive data) channel 1
	SENT_SENT7C			Receive input channel 7
	EDSADC_DSCIN1B			Modulator clock input, channel 1
	IOM_PIN_3			GPIO pad input to FPC
	EVADC_G10CH4			AI
	P33.3	O0	General-purpose output	
	GTM_TOUT25	O1	GTM muxed output	
	IOM_MON0_3		Monitor input 0	
	IOM_GTM_3		GTM-provided inputs to EXOR combiner	
	ASCLIN5_ASCLK		O2	Shift clock output
	QSPI4_SLSO2	O3	Master slave select output	
	EDSADC_DSCOUT1	O4	Modulator clock output	
	EVADC_EMUX00	O5	Control of external analog multiplexer interface 0	
	—	O6	Reserved	
	—	O7	Reserved	

TC37xEXT Pin Definition and Functions LQFP-176 Package Pinning of

Table 2-51 Port 33 Functions (cont'd)

Pin	Symbol	Ctrl.	Buffer Type	Function	
74	P33.4	I	SLOW / PU1 / VEVRSB / ES5	General-purpose input	
	GTM_TIM4_IN4_10			Mux input channel 4 of TIM module 4	
	GTM_TIM1_IN0_10			Mux input channel 0 of TIM module 1	
	GTM_TIM0_IN0_10			Mux input channel 0 of TIM module 0	
	EDSADC_ITR0F			Trigger/Gate input, channel 0	
	SENT_SENT6C			Receive input channel 6	
	EDSADC_DSDIN1B			Digital datastream input, channel 1	
	CCU61_CTRAPC			Trap input capture	
	ASCLIN5_ARXB			Receive input	
	IOM_PIN_4			GPIO pad input to FPC	
	GTM_DTMT2_0			CDTM2_DTM0	
	EVADC_G10CH3			AI	Analog input channel 3, group 10
	P33.4			O0	General-purpose output
	GTM_TOUT26	O1	GTM muxed output		
	IOM_MON0_4		Monitor input 0		
	IOM_GTM_4		GTM-provided inputs to EXOR combiner		
	ASCLIN2_ARTS	O2	Ready to send output		
	QSPI2_SLSO12	O3	Master slave select output		
	PSI5_TX1	O4	TXD outputs (send data)		
	IOM_MON1_15		Monitor input 1		
EVADC_EMUX12	O5		Control of external analog multiplexer interface 1		
EVADC_FC0BFLOUT	O6		Boundary flag output, FC channel 0		
CAN13_TXD	O7	CAN transmit output node 3			

TC37xEXT Pin Definition and Functions LQFP-176 Package Pinning of

Table 2-51 Port 33 Functions (cont'd)

Pin	Symbol	Ctrl.	Buffer Type	Function
75	P33.5	I	SLOW / PU1 / VEVRSB / ES5	General-purpose input
	GTM_TIM4_IN5_10			Mux input channel 5 of TIM module 4
	GTM_TIM1_IN1_8			Mux input channel 1 of TIM module 1
	GTM_TIM0_IN1_8			Mux input channel 1 of TIM module 0
	EDSADC_DSCIN0B			Modulator clock input, channel 0
	EDSADC_ITR1F			Trigger/Gate input, channel 1
	GPT120_T4EUDB			Count direction control input of timer T4
	PSI5S_RXC			RX data input
	ASCLIN2_ACTSB			Clear to send input
	CCU61_CCPOS2C			Hall capture input 2
	SENT_SENT5C			Receive input channel 5
	CAN13_RXDB			CAN receive input node 3
	IOM_PIN_5			GPIO pad input to FPC
	EVADC_G10CH2	AI	Analog input channel 2, group 10	
	P33.5	O0	General-purpose output	
	GTM_TOUT27	O1	GTM muxed output	
	IOM_MON0_5		Monitor input 0	
	IOM_GTM_5		GTM-provided inputs to EXOR combiner	
	QSPI0_SLSO7	O2	Master slave select output	
	QSPI1_SLSO7	O3	Master slave select output	
EDSADC_DSCOUT0	O4	Modulator clock output		
EVADC_EMUX11	O5	Control of external analog multiplexer interface 1		
EVADC_FC2BFLOUT	O6	Boundary flag output, FC channel 2		
ASCLIN5_ASLSO	O7	Slave select signal output		

TC37xEXT Pin Definition and Functions LQFP-176 Package Pinning of

Table 2-51 Port 33 Functions (cont'd)

Pin	Symbol	Ctrl.	Buffer Type	Function	
76	P33.6	I	SLOW / PU1 / VEVRSB / ES5	General-purpose input	
	GTM_TIM1_IN2_9			Mux input channel 2 of TIM module 1	
	GTM_TIM0_IN2_9			Mux input channel 2 of TIM module 0	
	EDSADC_ITR2F			Trigger/Gate input, channel 2	
	GPT120_T2EUDB			Count direction control input of timer T2	
	SENT_SENT4C			Receive input channel 4	
	CCU61_CCPOS1C			Hall capture input 1	
	EDSADC_DSDIN0B			Digital datastream input, channel 0	
	ASCLIN8_ARXD			Receive input	
	IOM_PIN_6			GPIO pad input to FPC	
	GTM_DTMT2_1			CDTM2_DTM0	
	EVADC_G10CH1			AI	Analog input channel 1, group 10
	P33.6			O0	General-purpose output
	GTM_TOUT28	O1	GTM muxed output		
	IOM_MON0_6		Monitor input 0		
	IOM_GTM_6		GTM-provided inputs to EXOR combiner		
	ASCLIN2_ASLSO	O2	Slave select signal output		
	QSPI2_SLSO11	O3	Master slave select output		
	—	O4	Reserved		
	EVADC_EMUX10	O5	Control of external analog multiplexer interface 1		
EVADC_FC1BFLOUT	O6	Boundary flag output, FC channel 1			
PSI5S_TX	O7	TX data output			

TC37xEXT Pin Definition and Functions LQFP-176 Package Pinning of

Table 2-51 Port 33 Functions (cont'd)

Pin	Symbol	Ctrl.	Buffer Type	Function
77	P33.7	I	SLOW / PU1 / VEVRSB / ES5	General-purpose input
	GTM_TIM1_IN3_9			Mux input channel 3 of TIM module 1
	GTM_TIM0_IN3_9			Mux input channel 3 of TIM module 0
	CAN00_RXDE			CAN receive input node 0
	GPT120_T2INB			Trigger/gate input of timer T2
	CCU61_CCPOS0C			Hall capture input 0
	SCU_E_REQ4_0			ERU Channel 4 inputs 0 to 5 (0 is the LSB and 5 is the MSB)
	SENT_SENT14C			Receive input channel 14
	IOM_PIN_7			GPIO pad input to FPC
	EVADC_G10CH0	AI	Analog input channel 0, group 10	
	P33.7	O0	General-purpose output	
	GTM_TOUT29	O1	GTM muxed output	
	IOM_MON0_7	O1	Monitor input 0	
	IOM_GTM_7		GTM-provided inputs to EXOR combiner	
	ASCLIN2_ASCLK	O2	Shift clock output	
	QSPI4_SLSO7	O3	Master slave select output	
	ASCLIN8_ATX	O4	Transmit output	
	—	O5	Reserved	
	EVADC_FC3BFLOUT	O6	Boundary flag output, FC channel 3	
—	O7	Reserved		

TC37xEXT Pin Definition and Functions LQFP-176 Package Pinning of

Table 2-51 Port 33 Functions (cont'd)

Pin	Symbol	Ctrl.	Buffer Type	Function
78	P33.8	I	FAST / HighZ / VEVR SB	General-purpose input
	GTM_TIM1_IN4_7			Mux input channel 4 of TIM module 1
	GTM_TIM0_IN4_7			Mux input channel 4 of TIM module 0
	ASCLIN2_ARXE			Receive input
	SCU_EMGSTOP_PORT_A			Emergency stop Port Pin A input request
	IOM_PIN_8			GPIO pad input to FPC
	P33.8	O0	General-purpose output	
	GTM_TOUT30	O1	GTM muxed output	
	IOM_MON0_8	O2	Monitor input 0	
	ASCLIN2_ATX		Transmit output	
	IOM_MON2_14		Monitor input 2	
	IOM_REF2_14	Reference input 2		
	QSPI4_SLSO2	O3	Master slave select output	
	—	O4	Reserved	
	CAN00_TXD	O5	CAN transmit output node 0	
	IOM_MON2_5	O6	Monitor input 2	
	IOM_REF2_5		Reference input 2	
	—		Reserved	
	CCU61_COUT62	O7	T12 PWM channel 62	
	IOM_MON1_13	O	Monitor input 1	
IOM_REF1_8	Reference input 1			
SMU_FSP0		FSP[1..0] Output Signals - Generated by SMU_core		

TC37xEXT Pin Definition and Functions LQFP-176 Package Pinning of

Table 2-51 Port 33 Functions (cont'd)

Pin	Symbol	Ctrl.	Buffer Type	Function
79	P33.9	I	SLOW / PU1 / VEVRSB / ES5	General-purpose input
	GTM_TIM1_IN1_9			Mux input channel 1 of TIM module 1
	GTM_TIM0_IN1_9			Mux input channel 1 of TIM module 0
	IOM_PIN_9			GPIO pad input to FPC
	P33.9	O0		General-purpose output
	GTM_TOUT31	O1		GTM muxed output
	IOM_MON0_9			Monitor input 0
	ASCLIN2_ATX	O2		Transmit output
	IOM_MON2_14			Monitor input 2
	IOM_REF2_14			Reference input 2
	QSPI4_SLSO1	O3		Master slave select output
	ASCLIN2_ASCLK	O4		Shift clock output
	CAN01_TXD	O5		CAN transmit output node 1
	IOM_MON2_6			Monitor input 2
	IOM_REF2_6			Reference input 2
	ASCLIN0_ATX	O6		Transmit output
	IOM_MON2_12			Monitor input 2
	IOM_REF2_12			Reference input 2
	CCU61_CC62	O7		T12 PWM channel 62
	IOM_MON1_10			Monitor input 1
IOM_REF1_11			Reference input 1	

TC37xEXT Pin Definition and Functions LQFP-176 Package Pinning of

Table 2-51 Port 33 Functions (cont'd)

Pin	Symbol	Ctrl.	Buffer Type	Function
80	P33.10	I	FAST / PU1 / VEVR SB / ES5	General-purpose input
	GTM_TIM4_IN4_14			Mux input channel 4 of TIM module 4
	GTM_TIM1_IN0_9			Mux input channel 0 of TIM module 1
	GTM_TIM0_IN0_9			Mux input channel 0 of TIM module 0
	QSPI4_SLSIA			Slave select input
	CAN01_RXDD			CAN receive input node 1
	ASCLIN0_ARXD			Receive input
	IOM_PIN_10			GPIO pad input to FPC
	P33.10			O0
	GTM_TOUT32	O1	GTM muxed output	
	IOM_MON0_10	O2	Monitor input 0	
	QSPI1_SLSO6		Master slave select output	
	QSPI4_SLSO0		Master slave select output	
	ASCLIN1_ASLSO	O4	Slave select signal output	
	PSI5S_CLK	O5	PSI5S CLK is a clock that can be used on a pin to drive the external PHY.	
	—	O6	Reserved	
	CCU61_COUT61	O7	T12 PWM channel 61	
	IOM_MON1_12		Monitor input 1	
	IOM_REF1_9		Reference input 1	
SMU_FSP1	O	FSP[1..0] Output Signals - Generated by SMU_core		
81	P33.11	I	FAST / PU1 / VEVR SB / ES5	General-purpose input
	GTM_TIM1_IN2_8			Mux input channel 2 of TIM module 1
	GTM_TIM0_IN2_8			Mux input channel 2 of TIM module 0
	QSPI4_SCLKA			Slave SPI clock inputs
	IOM_PIN_11			GPIO pad input to FPC
	P33.11	O0	General-purpose output	
	GTM_TOUT33	O1	GTM muxed output	
	IOM_MON0_11	O2	Monitor input 0	
	ASCLIN1_ASCLK		Shift clock output	
	QSPI4_SCLK		Master SPI clock output	
	—	O4	Reserved	
	—	O5	Reserved	
	EDSADC_CGPWMN	O6	Negative carrier generator output	
	CCU61_CC61	O7	T12 PWM channel 61	
	IOM_MON1_9		Monitor input 1	
IOM_REF1_12	Reference input 1			

TC37xEXT Pin Definition and Functions LQFP-176 Package Pinning of

Table 2-51 Port 33 Functions (cont'd)

Pin	Symbol	Ctrl.	Buffer Type	Function
82	P33.12	I	FAST / PU1 / VEVRSB / ES5	General-purpose input
	GTM_TIM3_IN0_6			Mux input channel 0 of TIM module 3
	GTM_TIM2_IN0_6			Mux input channel 0 of TIM module 2
	QSPI4_MTSRA			Slave SPI data input
	CAN00_RXDD			CAN receive input node 0
	PMS_PINBWKP			PINB (P33.12) pin input
	IOM_PIN_12			GPIO pad input to FPC
	P33.12	O0		General-purpose output
	GTM_TOUT34	O1		GTM muxed output
	IOM_MON0_12			Monitor input 0
	ASCLIN1_ATX	O2		Transmit output
	IOM_MON2_13			Monitor input 2
	IOM_REF2_13			Reference input 2
	QSPI4_MTSR	O3		Master SPI data output
	ASCLIN1_ASCLK	O4		Shift clock output
	CAN22_TXD	O5		CAN transmit output node 2
	EDSADC_CGPWMP	O6		Positive carrier generator output
	CCU61_COUT60	O7		T12 PWM channel 60
	IOM_MON1_11			Monitor input 1
	IOM_REF1_10			Reference input 1

TC37xEXT Pin Definition and Functions LQFP-176 Package Pinning of

Table 2-51 Port 33 Functions (cont'd)

Pin	Symbol	Ctrl.	Buffer Type	Function
83	P33.13	I	FAST / PU1 / VEVR5B / ES5	General-purpose input
	GTM_TIM3_IN1_5			Mux input channel 1 of TIM module 3
	GTM_TIM2_IN1_5			Mux input channel 1 of TIM module 2
	ASCLIN1_ARXF			Receive input
	EDSADC_SGNB			Carrier sign signal input
	QSPI4_MRSTA			Master SPI data input
	MSC1_INJ1			Injection signal from port
	CAN22_RXDA			CAN receive input node 2
	P33.13			O0
	GTM_TOUT35	O1	GTM muxed output	
	ASCLIN1_ATX	O2	Transmit output	
	IOM_MON2_13	O3	Monitor input 2	
	IOM_REF2_13		Reference input 2	
	QSPI4_MRST		Slave SPI data output	
	IOM_MON2_4	O4	Monitor input 2	
	IOM_REF2_4		Reference input 2	
	QSPI2_SLSO6	O4	Master slave select output	
	CAN00_TXD	O5	CAN transmit output node 0	
	IOM_MON2_5	O6	Monitor input 2	
	IOM_REF2_5		Reference input 2	
	—	O6	Reserved	
CCU61_CC60	O7	T12 PWM channel 60		
IOM_MON1_8	O7	Monitor input 1		
IOM_REF1_13		Reference input 1		

Table 2-52 Analog Inputs

Pin	Symbol	Ctrl.	Buffer Type	Function
67	AN0	I	D / HighZ / VDDM	Analog Input 0
	EVADC_G0CH0			Analog input channel 0, group 0
	EDSADC_EDS3PA			Positive analog input channel 3, pin A
66	AN1	I	D / HighZ / VDDM	Analog Input 1
	EVADC_G0CH1			Analog input channel 1, group 0
	EDSADC_EDS3NA			Negative analog input channel 3, pin A
65	AN2	I	D / HighZ / VDDM	Analog Input 2
	EVADC_G0CH2			Analog input channel 2, group 0
	EDSADC_EDS0PA			Positive analog input channel 0, pin A

TC37xEXT Pin Definition and Functions LQFP-176 Package Pinning of

Table 2-52 Analog Inputs (cont'd)

Pin	Symbol	Ctrl.	Buffer Type	Function
64	AN3	I	D / HighZ / VDDM	Analog Input 3
	EVADC_G0CH3			Analog input channel 3, group 0
	EDSADC_EDS0NA			Negative analog input channel 0, pin A
63	AN4	I	D / HighZ / VDDM	Analog Input 4
	EVADC_G11CH0			Analog input channel 0, group 11
	EVADC_G0CH4			Analog input channel 4, group 0
62	AN5	I	D / HighZ / VDDM	Analog Input 5
	EVADC_G11CH1			Analog input channel 1, group 11
	EVADC_G0CH5			Analog input channel 5, group 0
61	AN6	I	D / HighZ / VDDM	Analog Input 6
	EVADC_G11CH2			Analog input channel 2, group 11
	EVADC_G0CH6			Analog input channel 6, group 0
60	AN7	I	D / HighZ / VDDM	Analog Input 7
	EVADC_G11CH3			Analog input channel 3, group 11
	EVADC_G0CH7			Analog input channel 7, group 0
59	AN8	I	D / HighZ / VDDM	Analog Input 8
	EVADC_G11CH4			Analog input channel 4, group 11
	EVADC_G1CH0			Analog input channel 0, group 1
58	AN10	I	D / HighZ / VDDM	Analog Input 10
	EVADC_G11CH6			Analog input channel 6, group 11
	EVADC_G1CH2			Analog input channel 2, group 1
57	AN11	I	D / HighZ / VDDM	Analog Input 11
	EVADC_G11CH7			Analog input channel 7, group 11
	EVADC_G1CH3			Analog input channel 3, group 1
56	AN12	I	D / HighZ / VDDM	Analog Input 12
	EVADC_G1CH4			Analog input channel 4, group 1
	EDSADC_EDS0PB			Positive analog input channel 0, pin B
55	AN13	I	D / HighZ / VDDM	Analog Input 13
	EVADC_G1CH5			Analog input channel 5, group 1
	EDSADC_EDS0NB			Negative analog input channel 0, pin B
50	AN16	I	D / HighZ / VDDM	Analog Input 16
	EVADC_G2CH0			Analog input channel 0, group 2
	EVADC_FC0CH0			Analog input FC channel 0
49	AN17/P40.10	I	S / HighZ / VDDM	Analog Input 17
	SENT_SENT10A			Receive input channel 10
	EVADC_G2CH1			Analog input channel 1, group 2
	EVADC_FC1CH0			Analog input FC channel 1

TC37xEXT Pin Definition and Functions LQFP-176 Package Pinning of

Table 2-52 Analog Inputs (cont'd)

Pin	Symbol	Ctrl.	Buffer Type	Function
48	AN18/P40.11	I	S / HighZ / VDDM	Analog Input 18
	SENT_SENT11A			Receive input channel 11
	EVADC_G11CH8			Analog input channel 8, group 11
	EVADC_G2CH2			Analog input channel 2, group 2
47	AN19/P40.12	I	S / HighZ / VDDM	Analog Input 19
	SENT_SENT12A			Receive input channel 12
	EVADC_G11CH9			Analog input channel 9, group 11
	EVADC_G2CH3			Analog input channel 3, group 2
46	AN20	I	D / HighZ / VDDM	Analog Input 20
	EVADC_G2CH4			Analog input channel 4, group 2
	EDSADC_EDS2PA			Positive analog input channel 2, pin A
45	AN21	I	D / HighZ / VDDM	Analog Input 21
	EVADC_G2CH5			Analog input channel 5, group 2
	EDSADC_EDS2NA			Negative analog input channel 2, pin A
44	AN24/P40.0	I	S / HighZ / VDDM	Analog Input 24
	SENT_SENT0A			Receive input channel 0
	EVADC_G3CH0			Analog input channel 0, group 3
	CCU60_CCPOS0D			Hall capture input 0
	EDSADC_EDS2PB			Positive analog input channel 2, pin B
43	AN25/P40.1	I	S / HighZ / VDDM	Analog Input 25
	SENT_SENT1A			Receive input channel 1
	EVADC_G3CH1			Analog input channel 1, group 3
	CCU60_CCPOS1B			Hall capture input 1
	EDSADC_EDS2NB			Negative analog input channel 2, pin B
42	AN26/P40.2	I	S / HighZ / VDDM	Analog Input 26
	SENT_SENT2A			Receive input channel 2
	EVADC_G3CH2			Analog input channel 2, group 3
	CCU60_CCPOS1D			Hall capture input 1
	EVADC_G11CH10			Analog input channel 10, group 11
41	AN27/P40.3	I	S / HighZ / VDDM	Analog Input 27
	SENT_SENT3A			Receive input channel 3
	EVADC_G3CH3			Analog input channel 3, group 3
	CCU60_CCPOS2B			Hall capture input 2
	EVADC_G11CH11			Analog input channel 11, group 11
40	AN28/P40.13	I	S / HighZ / VDDM	Analog Input 28
	SENT_SENT13A			Receive input channel 13
	EVADC_G3CH4			Analog input channel 4, group 3

TC37xEXT Pin Definition and Functions LQFP-176 Package Pinning of

Table 2-52 Analog Inputs (cont'd)

Pin	Symbol	Ctrl.	Buffer Type	Function
39	AN29/P40.14	I	S / HighZ / VDDM	Analog Input 29
	SENT_SENT14A			Receive input channel 14
	EVADC_G3CH5			Analog input channel 5, group 3
38	AN32/P40.4	I	S / HighZ / VDDM	Analog Input 32
	SENT_SENT4A			Receive input channel 4
	EVADC_G8CH0			Analog input channel 0, group 8
	CCU60_CCPOS2D			Hall capture input 2
	EVADC_G11CH12			Analog input channel 12, group 11
37	AN33/P40.5	I	S / HighZ / VDDM	Analog Input 33
	SENT_SENT5A			Receive input channel 5
	EVADC_G8CH1			Analog input channel 1, group 8
	CCU61_CCPOS0D			Hall capture input 0
	EVADC_G11CH13			Analog input channel 13, group 11
36	AN35	I	D / HighZ / VDDM	Analog Input 35
	EVADC_G8CH3			Analog input channel 3, group 8
	EVADC_G11CH15			Analog input channel 15, group 11
35	AN36/P40.6	I	S / HighZ / VDDM	Analog Input 36
	SENT_SENT6A			Receive input channel 6
	EVADC_G8CH4			Analog input channel 4, group 8
	CCU61_CCPOS1B			Hall capture input 1
	EDSADC_EDS1PA			Positive analog input channel 1, pin A
34	AN37/P40.7	I	S / HighZ / VDDM	Analog Input 37
	SENT_SENT7A			Receive input channel 7
	EVADC_G8CH5			Analog input channel 5, group 8
	CCU61_CCPOS1D			Hall capture input 1
	EDSADC_EDS1NA			Negative analog input channel 1, pin A
33	AN38/P40.8	I	S / HighZ / VDDM	Analog Input 38
	SENT_SENT8A			Receive input channel 8
	EVADC_G8CH6			Analog input channel 6, group 8
	CCU61_CCPOS2B			Hall capture input 2
	EDSADC_EDS1PB			Positive analog input channel 1, pin B
32	AN39/P40.9	I	S / HighZ / VDDM	Analog Input 39
	SENT_SENT9A			Receive input channel 9
	EVADC_G8CH7			Analog input channel 7, group 8
	CCU61_CCPOS2D			Hall capture input 2
	EDSADC_EDS1NB			Negative analog input channel 1, pin B

TC37xEXT Pin Definition and Functions LQFP-176 Package Pinning of

Table 2-52 Analog Inputs (cont'd)

Pin	Symbol	Ctrl.	Buffer Type	Function
31	AN44	I	D / HighZ / VDDM	Analog Input 44
	EVADC_G8CH12			Analog input channel 12, group 8
	EDSADC_EDS1PC			Positive analog input channel 1, pin C
30	AN45	I	D / HighZ / VDDM	Analog Input 45
	EVADC_G8CH13			Analog input channel 13, group 8
	EDSADC_EDS1NC			Negative analog input channel 1, pin C
29	AN46	I	D / HighZ / VDDM	Analog Input 46
	EVADC_G8CH14			Analog input channel 14, group 8
	EDSADC_EDS1PD			Positive analog input channel 1, pin D
28	AN47	I	D / HighZ / VDDM	Analog Input 47
	EVADC_G8CH15			Analog input channel 15, group 8
	EDSADC_EDS1ND			Negative analog input channel 1, pin D

Table 2-53 System I/O

Pin	Symbol	Ctrl.	Buffer Type	Function
84	VGATE1N	O	—	DCDC N ch. MOSFET gate driver output P32.0 / SMPS mode: analog output. External Pass Device gate control for EVRC
85	VGATE1P	O	—	DCDC P ch. MOSFET gate driver output P32.1 / External Pass Device gate control for EVRC
102	XTAL1	I	XTAL / VEXT	XTAL pad1 XTAL1. Main Oscillator/PLL/Clock Generator Input.
103	XTAL2	O	XTAL / VEXT	XTAL pad2 XTAL2. Main Oscillator/PLL/Clock Generator OUTPUT
112	TMS	I	FAST / PD2 / VEXT	JTAG Module State Machine Control Input TMS: JTAG Module State Machine Control Input. DAP: DAP1 Data I/O.
	DAP1	I/O		DAP: DAP1 Data I/O
114	TRST	I	FAST / PU2 / VEXT	JTAG Module Reset/Enable Input TRST_N: JTAG Module Reset/Enable Input. DAPE: DAPE0 Clock Input
	DAPE0	I		DAPE: DAPE0 Clock Input
115	TCK	I	FAST / PD2 / VEXT	JTAG Module Clock Input TCK: JTAG Module Clock Input. DAP: DAP0 Clock Input.
	DAP0	I		DAP: DAP0 Clock Input

TC37xEXT Pin Definition and Functions LQFP-176 Package Pinning of

Table 2-53 System I/O (cont'd)

Pin	Symbol	Ctrl.	Buffer Type	Function
120	$\overline{\text{ESR1}}$	I	FAST / PU1 / VEXT	ESR1 Port Pin input - can be used to trigger a reset or an NMI ESR1: External System Request Reset 1. Default NMI function. See also SCU chapter for details. Default after power-on can be different. See also SCU chapter 'Reset Control Unit' and SCU_IOCRR register description. PMS_EVRWUP: EVR Wakeup Pin
	PMS_ESR1WKP	I		ESR1 pin input
121	$\overline{\text{PORST}}$	I/O	PORST / PD / VEXT	PORST pin Power On Reset Input. Additional strong PD in case of power fail.
122	$\overline{\text{ESR0}}$	I	FAST / OD / VEXT	ESR0 Port Pin input - can be used to trigger a reset or an NMI ESR0: External System Request Reset 0. Default configuration during and after reset is open-drain driver. The driver drives low during power-on reset. This is valid additionally after deactivation of PORST_N until the internal reset phase has finished. See also SCU chapter for details. Default after power-on can be different. See also SCU chapter 'Reset Control Unit' and SCU_IOCRR register description. PMS_EVRWUP: EVR Wakeup Pin
	PMS_ESR0WKP	I		ESR0 pin input

Table 2-54 Supply

Pin	Symbol	Ctrl.	Buffer Type	Function
164	VFLEX	I	—	Digital Power Supply for Flex Port Pads (5V / 3.3V)
54	VDDM	I	—	ADC Analog Power Supply (5V / 3.3V)
154	VDDP3	I	—	Flash Power Supply (3.3V)
52	VAREF1	I	—	Positive Analog Reference Voltage 1
26	VAREF2	I	—	Positive Analog Reference Voltage 2
10	VDDSB (VDD)	I	—	Devices with integrated EMEM: EMEM SRAM Standby Power Supply, VDDSB (1.25V); Devices without integrated EMEM: VDD (1.25V)
69	VEVRSB	I	—	Standby Power Supply (5V / 3.3V) for the Standby SRAM
155	VDD	I	—	Digital Core Power Supply (1.25V)
24	VDD	I	—	Digital Core Power Supply (1.25V)
68	VDD	I	—	Digital Core Power Supply (1.25V)
100	VDD	I	—	Digital Core Power Supply (1.25V)
123	VDD	I	—	Digital Core Power Supply (1.25V)
153	VEXT	I	—	External Power Supply (5V / 3.3V)

TC37xEXT Pin Definition and Functions LQFP-176 Package Pinning of
Table 2-54 Supply (cont'd)

Pin	Symbol	Ctrl.	Buffer Type	Function
25	VEXT	I	—	External Power Supply (5V / 3.3V)
99	VEXT	I	—	External Power Supply (5V / 3.3V)
177	VSS	I	—	Digital Ground (Exposed PAD), VSS
53	VSSM	I	—	Analog Ground for VDDM
51	VAGND1	I	—	Negative Analog Reference Voltage 1
27	VAGND2	I	—	Negative Analog Reference Voltage 2
101	VSS	I	—	Oscillator Ground, VSS(OSC)
104	VEXT	I	—	Digital Power Supply for Oscillator (shall be supplied with same level as used for VEXT), VEXT(OSC)

TC37xEXT Pin Definition and Functions LQFP-144 Package Pinning of

2.4 LQFP-144 Package Pinning of TC37xEXT

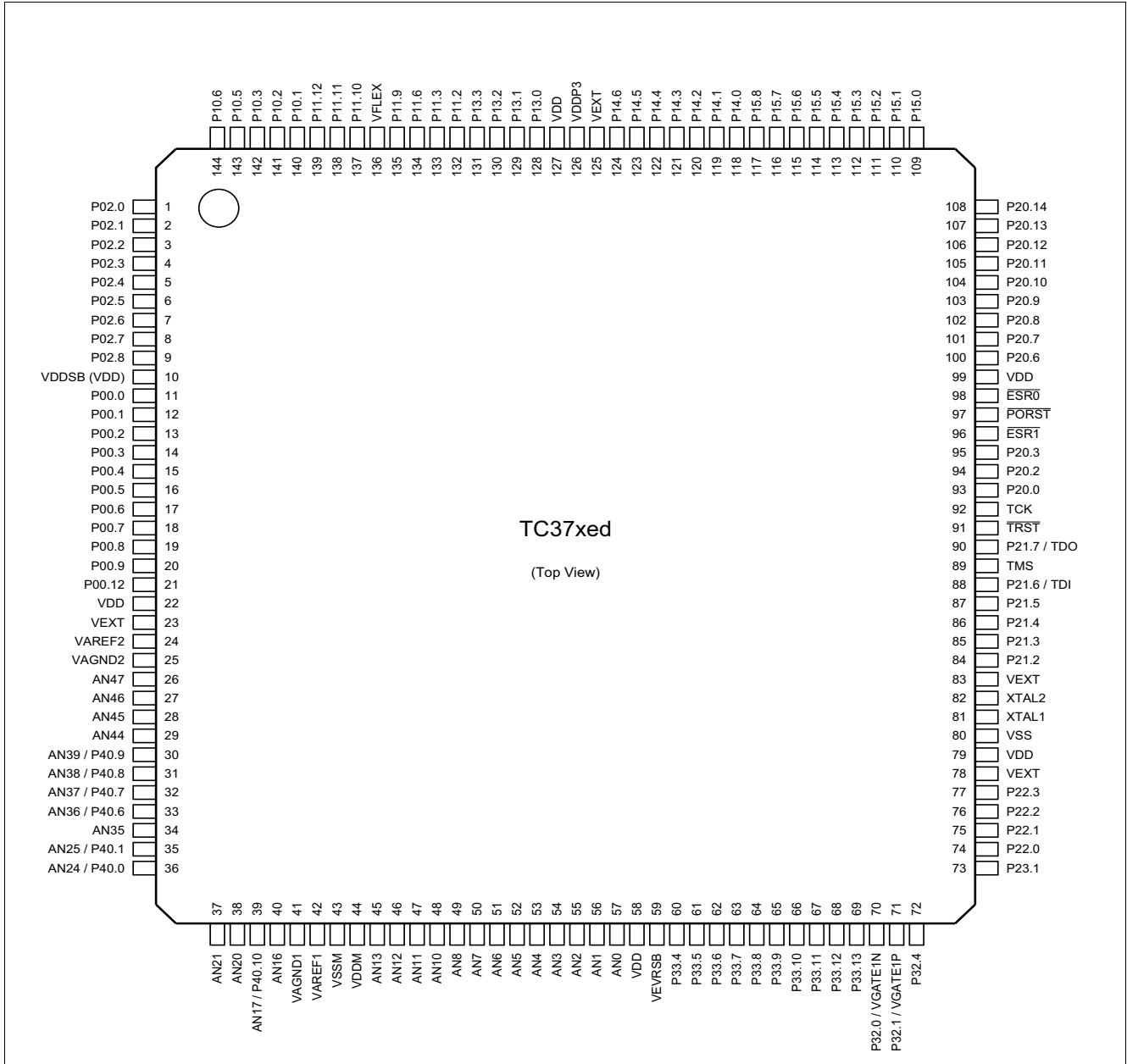

Figure 2-4 TC37xEXT package variant LQFP-144

TC37xEXT Pin Definition and Functions LQFP-144 Package Pinning of

Table 2-55 Port 00 Functions

Pin	Symbol	Ctrl.	Buffer Type	Function
11	P00.0	I	FAST / PU1 / VEXT / ES	General-purpose input
	GTM_TIM5_IN4_10			Mux input channel 4 of TIM module 5
	GTM_TIM3_IN0_1			Mux input channel 0 of TIM module 3
	GTM_TIM2_IN0_1			Mux input channel 0 of TIM module 2
	CCU61_CTRAPA			Trap input capture
	CCU60_T12HRE			External timer start 12
	MSC0_INJ0			Injection signal from port
	CIF_D9			sensor pixel data input
	GETH_MDIOA			MDIO Input
	P00.0			O0
	GTM_TOUT9	O1	GTM muxed output	
	IOM_REF0_9		Reference input 0	
	ASCLIN3_ASCLK	O2	Shift clock output	
	ASCLIN3_ATX	O3	Transmit output	
	IOM_MON2_15		Monitor input 2	
	IOM_REF2_15		Reference input 2	
	—	O4	Reserved	
	CAN10_TXD	O5	CAN transmit output node 0	
	—	O6	Reserved	
	CCU60_COUT63	O7	T13 PWM channel 63	
	IOM_MON1_6		Monitor input 1	
IOM_REF1_0		Reference input 1		
GETH_MDIO	O	MDIO Output		

TC37xEXT Pin Definition and Functions LQFP-144 Package Pinning of

Table 2-55 Port 00 Functions (cont'd)

Pin	Symbol	Ctrl.	Buffer Type	Function
12	P00.1	I	SLOW / PU1 / VEXT / ES	General-purpose input
	GTM_TIM5_IN5_11			Mux input channel 5 of TIM module 5
	GTM_TIM3_IN1_1			Mux input channel 1 of TIM module 3
	GTM_TIM2_IN1_1			Mux input channel 1 of TIM module 2
	CCU60_CC60INB			T12 capture input 60
	ASCLIN3_ARXE			Receive input
	EDSADC_DSCIN5A			Modulator clock input, channel 5
	CAN10_RXDA			CAN receive input node 0
	PSI5_RX0A			RXD inputs (receive data) channel 0
	CIF_D10			sensor pixel data input
	CCU61_CC60INA			T12 capture input 60
	SENT_SENT0B			Receive input channel 0
	EVADC_G9CH11			AI
	EDSADC_EDS5NA		Negative analog input channel 5, pin A	
	P00.1	O0	General-purpose output	
	GTM_TOUT10	O1	GTM muxed output	
	IOM_REF0_10		Reference input 0	
	ASCLIN3_ATX	O2	Transmit output	
	IOM_MON2_15		Monitor input 2	
	IOM_REF2_15		Reference input 2	
	—	O3	Reserved	
	EDSADC_DSCOUT5	O4	Modulator clock output	
	—	O5	Reserved	
	SENT_SPC0	O6	Transmit output	
	CCU61_CC60	O7	T12 PWM channel 60	
	IOM_MON1_8		Monitor input 1	
IOM_REF1_13		Reference input 1		

TC37xEXT Pin Definition and Functions LQFP-144 Package Pinning of

Table 2-55 Port 00 Functions (cont'd)

Pin	Symbol	Ctrl.	Buffer Type	Function
13	P00.2	I	SLOW / PU1 / VEXT / ES1	General-purpose input
	GTM_TIM5_IN6_11			Mux input channel 6 of TIM module 5
	GTM_TIM3_IN1_2			Mux input channel 1 of TIM module 3
	GTM_TIM2_IN1_2			Mux input channel 1 of TIM module 2
	EDSADC_DSDIN5A			Digital datastream input, channel 5
	SENT_SENT1B			Receive input channel 1
	CIF_D11			sensor pixel data input
	EVADC_G9CH10	AI	Analog input channel 10, group 9	
	EDSADC_EDS5PA		Positive analog input channel 5, pin A	
	P00.2	O0	General-purpose output	
	GTM_TOUT11	O1	GTM muxed output	
	IOM_REF0_11		Reference input 0	
	ASCLIN3_ASCLK	O2	Shift clock output	
	CAN21_TXD	O3	CAN transmit output node 1	
	PSI5_TX0	O4	TXD outputs (send data)	
	IOM_MON1_14		Monitor input 1	
	IOM_REF1_14		Reference input 1	
	CAN03_TXD		O5	CAN transmit output node 3
	IOM_MON2_8		Monitor input 2	
	IOM_REF2_8		Reference input 2	
	QSPI3_SLSO4	O6	Master slave select output	
	CCU61_COUT60	O7	T12 PWM channel 60	
	IOM_MON1_11		Monitor input 1	
IOM_REF1_10	Reference input 1			

TC37xEXT Pin Definition and Functions LQFP-144 Package Pinning of

Table 2-55 Port 00 Functions (cont'd)

Pin	Symbol	Ctrl.	Buffer Type	Function
14	P00.3	I	SLOW / PU1 / VEXT / ES1	General-purpose input
	GTM_TIM5_IN7_10			Mux input channel 7 of TIM module 5
	GTM_TIM3_IN2_1			Mux input channel 2 of TIM module 3
	GTM_TIM2_IN2_1			Mux input channel 2 of TIM module 2
	CCU60_CC61INB			T12 capture input 61
	EDSADC_DSCIN3A			Modulator clock input, channel 3
	EDSADC_ITR5F			Trigger/Gate input, channel 5
	PSI5_RX1A			RXD inputs (receive data) channel 1
	CAN03_RXDA			CAN receive input node 3
	CAN21_RXDA			CAN receive input node 1
	PSI5S_RXA			RX data input
	SENT_SENT2B			Receive input channel 2
	CIF_D12			sensor pixel data input
	CCU61_CC61INA			T12 capture input 61
	EVADC_G9CH9			AI
	EDSADC_EDS5NB		Negative analog input channel 5, pin B	
	P00.3	O0	General-purpose output	
	GTM_TOUT12	O1	GTM muxed output	
	IOM_REF0_12		Reference input 0	
	ASCLIN3_ASLSO	O2	Slave select signal output	
	—	O3	Reserved	
	EDSADC_DSCOUT3	O4	Modulator clock output	
	—	O5	Reserved	
SENT_SPC2	O6	Transmit output		
CCU61_CC61	O7	T12 PWM channel 61		
IOM_MON1_9		Monitor input 1		
IOM_REF1_12		Reference input 1		

TC37xEXT Pin Definition and Functions LQFP-144 Package Pinning of

Table 2-55 Port 00 Functions (cont'd)

Pin	Symbol	Ctrl.	Buffer Type	Function	
15	P00.4	I	SLOW / PU1 / VEXT / ES1	General-purpose input	
	GTM_TIM3_IN3_1			Mux input channel 3 of TIM module 3	
	GTM_TIM2_IN3_1			Mux input channel 3 of TIM module 2	
	SCU_E_REQ2_2			ERU Channel 2 inputs 0 to 5 (0 is the LSB and 5 is the MSB)	
	SENT_SENT3B			Receive input channel 3	
	EDSADC_DSDIN3A			Digital datastream input, channel 3	
	EDSADC_SGNA			Carrier sign signal input	
	ASCLIN10_ARXA			Receive input	
	CIF_D13			sensor pixel data input	
	EVADC_G9CH8			AI	Analog input channel 8, group 9
	EDSADC_EDS5PB				Positive analog input channel 5, pin B
	P00.4			O0	General-purpose output
	GTM_TOUT13			O1	GTM muxed output
	IOM_REF0_13		Reference input 0		
	PSI5S_TX	O2	TX data output		
	CAN11_TXD	O3	CAN transmit output node 1		
	PSI5_TX1	O4	TXD outputs (send data)		
	IOM_MON1_15		Monitor input 1		
	—	O5	Reserved		
	SENT_SPC3	O6	Transmit output		
	CCU61_COUT61	O7	T12 PWM channel 61		
	IOM_MON1_12		Monitor input 1		
	IOM_REF1_9		Reference input 1		

TC37xEXT Pin Definition and Functions LQFP-144 Package Pinning of

Table 2-55 Port 00 Functions (cont'd)

Pin	Symbol	Ctrl.	Buffer Type	Function
16	P00.5	I	SLOW / PU1 / VEXT / ES1	General-purpose input
	GTM_TIM3_IN4_1			Mux input channel 4 of TIM module 3
	GTM_TIM3_IN0_11			Mux input channel 0 of TIM module 3
	GTM_TIM2_IN4_1			Mux input channel 4 of TIM module 2
	CCU60_CC62INB			T12 capture input 62
	EDSADC_DSCIN2A			Modulator clock input, channel 2
	CCU61_CC62INA			T12 capture input 62
	SENT_SENT4B			Receive input channel 4
	CIF_D14			sensor pixel data input
	CAN11_RXDB			CAN receive input node 1
	GTM_DTMT1_1			CDTM1_DTM0
	EVADC_G9CH7			AI
	P00.5	O0	General-purpose output	
	GTM_TOUT14	O1	GTM muxed output	
	IOM_REF0_14		Reference input 0	
	EDSADC_CGPWMN	O2	Negative carrier generator output	
	QSPI3_SLSO3	O3	Master slave select output	
	EDSADC_DSCOUT2	O4	Modulator clock output	
	EVADC_FC0BFLOUT	O5	Boundary flag output, FC channel 0	
	SENT_SPC4	O6	Transmit output	
CCU61_CC62	O7	T12 PWM channel 62		
IOM_MON1_10		Monitor input 1		
IOM_REF1_11		Reference input 1		

TC37xEXT Pin Definition and Functions LQFP-144 Package Pinning of

Table 2-55 Port 00 Functions (cont'd)

Pin	Symbol	Ctrl.	Buffer Type	Function
17	P00.6	I	SLOW / PU1 / VEXT / ES1	General-purpose input
	GTM_TIM3_IN5_1			Mux input channel 5 of TIM module 3
	GTM_TIM3_IN1_14			Mux input channel 1 of TIM module 3
	GTM_TIM2_IN5_1			Mux input channel 5 of TIM module 2
	EDSADC_ITR4F			Trigger/Gate input, channel 4
	EDSADC_DSDIN2A			Digital datastream input, channel 2
	SENT_SENT5B			Receive input channel 5
	CIF_D15			sensor pixel data input
	ASCLIN5_ARXA			Receive input
	EVADC_G9CH6			AI
	P00.6	O0	General-purpose output	
	GTM_TOUT15	O1	GTM muxed output	
	IOM_REF0_15		Reference input 0	
	EDSADC_CGPWMP	O2	Positive carrier generator output	
	—	O3	Reserved	
	—	O4	Reserved	
	EVADC_EMUX10	O5	Control of external analog multiplexer interface 1	
	SENT_SPC5	O6	Transmit output	
	CCU61_COUT62	O7	T12 PWM channel 62	
	IOM_MON1_13		Monitor input 1	
IOM_REF1_8		Reference input 1		

TC37xEXT Pin Definition and Functions LQFP-144 Package Pinning of

Table 2-55 Port 00 Functions (cont'd)

Pin	Symbol	Ctrl.	Buffer Type	Function
18	P00.7	I	SLOW / PU1 / VEXT / ES1	General-purpose input
	GTM_TIM3_IN6_1			Mux input channel 6 of TIM module 3
	GTM_TIM3_IN2_11			Mux input channel 2 of TIM module 3
	GTM_TIM2_IN6_1			Mux input channel 6 of TIM module 2
	CCU61_CC60INC			T12 capture input 60
	SENT_SENT6B			Receive input channel 6
	EDSADC_DSCIN4A			Modulator clock input, channel 4
	GPT120_T2INA			Trigger/gate input of timer T2
	CCU61_CCPOS0A			Hall capture input 0
	CCU60_T12HRB			External timer start 12
	CIF_PCLK			Sensor Pixel Clock input
	GTM_DTMT0_2			CDTM0_DTM0
	EVADC_G9CH5			AI
	EDSADC_EDS4NA	Negative analog input channel 4, pin A		
	P00.7	O0	General-purpose output	
	GTM_TOUT16	O1	GTM muxed output	
	ASCLIN5_ATX	O2	Transmit output	
	EVADC_FC2BFLOUT	O3	Boundary flag output, FC channel 2	
	EDSADC_DSCOUT4	O4	Modulator clock output	
	EVADC_EMUX11	O5	Control of external analog multiplexer interface 1	
	SENT_SPC6	O6	Transmit output	
	CCU61_CC60	O7	T12 PWM channel 60	
	IOM_MON1_8	Monitor input 1		
IOM_REF1_13	Reference input 1			

TC37xEXT Pin Definition and Functions LQFP-144 Package Pinning of

Table 2-55 Port 00 Functions (cont'd)

Pin	Symbol	Ctrl.	Buffer Type	Function
19	P00.8	I	SLOW / PU1 / VEXT / ES1	General-purpose input
	GTM_TIM3_IN7_1			Mux input channel 7 of TIM module 3
	GTM_TIM3_IN3_11			Mux input channel 3 of TIM module 3
	GTM_TIM2_IN7_1			Mux input channel 7 of TIM module 2
	CCU61_CC61INC			T12 capture input 61
	SENT_SENT7B			Receive input channel 7
	EDSADC_DSDIN4A			Digital datastream input, channel 4
	GPT120_T2EUDA			Count direction control input of timer T2
	CCU61_CCPOS1A			Hall capture input 1
	CIF_VSYNC			vertical synchronization signal input
	CCU60_T13HRB			External timer start 13
	ASCLIN10_ARXB			Receive input
	EVADC_G9CH4			AI
	EDSADC_EDS4PA	Positive analog input channel 4, pin A		
	P00.8	O0	General-purpose output	
	GTM_TOUT17	O1	GTM muxed output	
	QSPI3_SLSO6	O2	Master slave select output	
	ASCLIN10_ATX	O3	Transmit output	
	—	O4	Reserved	
	EVADC_EMUX12	O5	Control of external analog multiplexer interface 1	
	SENT_SPC7	O6	Transmit output	
	CCU61_CC61	O7	T12 PWM channel 61	
	IOM_MON1_9		Monitor input 1	
IOM_REF1_12	Reference input 1			

TC37xEXT Pin Definition and Functions LQFP-144 Package Pinning of

Table 2-55 Port 00 Functions (cont'd)

Pin	Symbol	Ctrl.	Buffer Type	Function
20	P00.9	I	SLOW / PU1 / VEXT / ES1	General-purpose input
	GTM_TIM4_IN0_7			Mux input channel 0 of TIM module 4
	GTM_TIM1_IN0_1			Mux input channel 0 of TIM module 1
	GTM_TIM0_IN0_1			Mux input channel 0 of TIM module 0
	CCU61_CC62INC			T12 capture input 62
	SENT_SENT8B			Receive input channel 8
	CCU61_CCPOS2A			Hall capture input 2
	EDSADC_DSCIN1A			Modulator clock input, channel 1
	EDSADC_ITR3F			Trigger/Gate input, channel 3
	GPT120_T4EUDA			Count direction control input of timer T4
	CCU60_T13HRC			External timer start 13
	CIF_HSYNC			horizontal synchronization signal input
	CCU60_T12HRC			External timer start 12
	EVADC_G9CH3			AI
	EDSADC_EDS4NB		Negative analog input channel 4, pin B	
	P00.9	O0	General-purpose output	
	GTM_TOUT18	O1	GTM muxed output	
	QSPI3_SLSO7	O2	Master slave select output	
	ASCLIN3_ARTS	O3	Ready to send output	
	EDSADC_DSCOUT1	O4	Modulator clock output	
ASCLIN4_ATX	O5	Transmit output		
SENT_SPC8	O6	Transmit output		
CCU61_CC62	O7	T12 PWM channel 62		
IOM_MON1_10		Monitor input 1		
IOM_REF1_11		Reference input 1		

TC37xEXT Pin Definition and Functions LQFP-144 Package Pinning of

Table 2-55 Port 00 Functions (cont'd)

Pin	Symbol	Ctrl.	Buffer Type	Function
21	P00.12	I	SLOW / PU1 / VEXT / ES1	General-purpose input
	GTM_TIM4_IN3_11			Mux input channel 3 of TIM module 4
	GTM_TIM1_IN3_1			Mux input channel 3 of TIM module 1
	GTM_TIM0_IN3_1			Mux input channel 3 of TIM module 0
	ASCLIN3_ACTSA			Clear to send input
	EDSADC_DSDIN0A			Digital datastream input, channel 0
	ASCLIN4_ARXA			Receive input
	SENT_SENT11B			Receive input channel 11
	EVADC_G9CH0			AI
	EVADC_FC2CH0	Analog input FC channel 2		
	P00.12	O0	General-purpose output	
	GTM_TOUT21	O1	GTM muxed output	
	—	O2	Reserved	
	—	O3	Reserved	
	—	O4	Reserved	
	—	O5	Reserved	
	—	O6	Reserved	
	CCU61_COUT63	O7	T13 PWM channel 63	
	IOM_MON1_7		Monitor input 1	
	IOM_REF1_7		Reference input 1	

TC37xEXT Pin Definition and Functions LQFP-144 Package Pinning of

Table 2-56 Port 02 Functions

Pin	Symbol	Ctrl.	Buffer Type	Function
1	P02.0	I	FAST / PU1 / VEXT / ES	General-purpose input
	GTM_TIM1_IN0_2			Mux input channel 0 of TIM module 1
	GTM_TIM0_IN0_2			Mux input channel 0 of TIM module 0
	CCU61_CC60INB			T12 capture input 60
	ASCLIN2_ARXG			Receive input
	CCU60_CC60INA			T12 capture input 60
	SCU_E_REQ3_2			ERU Channel 3 inputs 0 to 5 (0 is the LSB and 5 is the MSB)
	CIF_D0			sensor pixel data input
	GTM_DTMA0_0			CDTM0_DTM4
	P02.0			O0
	GTM_TOUT0	O1	GTM muxed output	
	IOM_REF0_0	O2	Reference input 0	
	ASCLIN2_ATX		Transmit output	
	IOM_MON2_14		Monitor input 2	
	IOM_REF2_14	O3	Reference input 2	
	QSPI3_SLSO1		Master slave select output	
	EDSADC_CGPWMN	O4	Negative carrier generator output	
	CAN00_TXD	O5	CAN transmit output node 0	
	IOM_MON2_5	O6	Monitor input 2	
	IOM_REF2_5		Reference input 2	
	ERAY0_TXDA	O7	Transmit Channel A	
	CCU60_CC60		T12 PWM channel 60	
	IOM_MON1_2		Monitor input 1	
	IOM_REF1_6		Reference input 1	

TC37xEXT Pin Definition and Functions LQFP-144 Package Pinning of

Table 2-56 Port 02 Functions (cont'd)

Pin	Symbol	Ctrl.	Buffer Type	Function
2	P02.1	I	SLOW / PU1 / VEXT / ES	General-purpose input
	GTM_TIM1_IN1_2			Mux input channel 1 of TIM module 1
	GTM_TIM0_IN1_2			Mux input channel 1 of TIM module 0
	ERAY0_RXDA2			Receive Channel A2
	ASCLIN2_ARXB			Receive input
	CAN00_RXDA			CAN receive input node 0
	SCU_E_REQ2_1			ERU Channel 2 inputs 0 to 5 (0 is the LSB and 5 is the MSB)
	CIF_D1			sensor pixel data input
	P02.1			O0
	GTM_TOUT1	O1	GTM muxed output	
	IOM_REF0_1	O2	Reference input 0	
	QSPI4_SLSO7		Master slave select output	
	QSPI3_SLSO2	O3	Master slave select output	
	EDSADC_CGPWMP	O4	Positive carrier generator output	
	—	O5	Reserved	
	—	O6	Reserved	
	CCU60_COUT60	O7	T12 PWM channel 60	
	IOM_MON1_3		Monitor input 1	
	IOM_REF1_3		Reference input 1	

TC37xEXT Pin Definition and Functions LQFP-144 Package Pinning of

Table 2-56 Port 02 Functions (cont'd)

Pin	Symbol	Ctrl.	Buffer Type	Function
3	P02.2	I	FAST / PU1 / VEXT / ES	General-purpose input
	GTM_TIM1_IN2_2			Mux input channel 2 of TIM module 1
	GTM_TIM0_IN2_2			Mux input channel 2 of TIM module 0
	CCU61_CC61INB			T12 capture input 61
	CCU60_CC61INA			T12 capture input 61
	CIF_D2			sensor pixel data input
	SENT_SENT14B			Receive input channel 14
	P02.2			O0
	GTM_TOUT2	O1	GTM muxed output	
	IOM_REF0_2	O2	Reference input 0	
	ASCLIN1_ATX		Transmit output	
	IOM_MON2_13		Monitor input 2	
	IOM_REF2_13	Reference input 2		
	QSPI3_SLSO3	O3	Master slave select output	
	PSI5_TX0	O4	TXD outputs (send data)	
	IOM_MON1_14	O5	Monitor input 1	
	IOM_REF1_14		Reference input 1	
	CAN02_TXD		CAN transmit output node 2	
	IOM_MON2_7	Monitor input 2		
	IOM_REF2_7	Reference input 2		
	ERAY0_TXDB	O6	Transmit Channel B	
	CCU60_CC61	O7	T12 PWM channel 61	
	IOM_MON1_1	O7	Monitor input 1	
	IOM_REF1_5		Reference input 1	

TC37xEXT Pin Definition and Functions LQFP-144 Package Pinning of

Table 2-56 Port 02 Functions (cont'd)

Pin	Symbol	Ctrl.	Buffer Type	Function
4	P02.3	I	SLOW / PU1 / VEXT / ES	General-purpose input
	GTM_TIM1_IN3_2			Mux input channel 3 of TIM module 1
	GTM_TIM0_IN3_2			Mux input channel 3 of TIM module 0
	EDSADC_DSCIN5B			Modulator clock input, channel 5
	ERAY0_RXDB2			Receive Channel B2
	CAN02_RXDB			CAN receive input node 2
	ASCLIN1_ARXG			Receive input
	MSC1_SD11			Upstream asynchronous input signal
	PSI5_RX0B			RXD inputs (receive data) channel 0
	CIF_D3			sensor pixel data input
	SENT_SENT13B			Receive input channel 13
	P02.3	O0	General-purpose output	
	GTM_TOUT3	O1	GTM muxed output	
	IOM_REF0_3		Reference input 0	
	ASCLIN2_ASLSO	O2	Slave select signal output	
	QSPI3_SLSO4	O3	Master slave select output	
	EDSADC_DSCOUT5	O4	Modulator clock output	
	—	O5	Reserved	
	—	O6	Reserved	
	CCU60_COUT61	O7	T12 PWM channel 61	
IOM_MON1_4		Monitor input 1		
IOM_REF1_2		Reference input 1		

TC37xEXT Pin Definition and Functions LQFP-144 Package Pinning of

Table 2-56 Port 02 Functions (cont'd)

Pin	Symbol	Ctrl.	Buffer Type	Function
5	P02.4	I	FAST / PU1 / VEXT / ES	General-purpose input
	GTM_TIM1_IN4_1			Mux input channel 4 of TIM module 1
	GTM_TIM0_IN4_1			Mux input channel 4 of TIM module 0
	CCU61_CC62INB			T12 capture input 62
	EDSADC_DSDIN5B			Digital datastream input, channel 5
	QSPI3_SLSIA			Slave select input
	CCU60_CC62INA			T12 capture input 62
	I2C0_SDAA			Serial Data Input 0
	CAN11_RXDA			CAN receive input node 1
	CAN0_ECTT1			External CAN time trigger input
	CIF_D4			sensor pixel data input
	SENT_SENT12B			Receive input channel 12
	P02.4			O0
	GTM_TOUT4	O1	GTM muxed output	
	IOM_REF0_4		Reference input 0	
	ASCLIN2_ASCLK	O2	Shift clock output	
	QSPI3_SLSO0	O3	Master slave select output	
	PSI5S_CLK	O4	PSI5S CLK is a clock that can be used on a pin to drive the external PHY.	
	I2C0_SDA	O5	Serial Data Output	
	ERAY0_TXENA	O6	Transmit Enable Channel A	
CCU60_CC62	O7	T12 PWM channel 62		
IOM_MON1_0		Monitor input 1		
IOM_REF1_4		Reference input 1		

TC37xEXT Pin Definition and Functions LQFP-144 Package Pinning of

Table 2-56 Port 02 Functions (cont'd)

Pin	Symbol	Ctrl.	Buffer Type	Function	
6	P02.5	I	FAST / PU1 / VEXT / ES	General-purpose input	
	GTM_TIM1_IN5_1			Mux input channel 5 of TIM module 1	
	GTM_TIM0_IN5_1			Mux input channel 5 of TIM module 0	
	EDSADC_DSCIN4B			Modulator clock input, channel 4	
	I2C0_SCLA			Serial Clock Input 0	
	PSI5_RX1B			RXD inputs (receive data) channel 1	
	PSI5S_RXB			RX data input	
	QSPI3_MRSTA			Master SPI data input	
	SENT_SENT3C			Receive input channel 3	
	CAN0_ECTT2			External CAN time trigger input	
	CIF_D5			sensor pixel data input	
	P02.5			O0	General-purpose output
	GTM_TOUT5			O1	GTM muxed output
	IOM_REF0_5		Reference input 0		
	CAN11_TXD	O2	CAN transmit output node 1		
	QSPI3_MRST	O3	Slave SPI data output		
	IOM_MON2_3		Monitor input 2		
	IOM_REF2_3		Reference input 2		
	EDSADC_DSCOUT4	O4	Modulator clock output		
	I2C0_SCL	O5	Serial Clock Output		
ERAY0_TXENB	O6	Transmit Enable Channel B			
CCU60_COUT62	O7	T12 PWM channel 62			
IOM_MON1_5		Monitor input 1			
IOM_REF1_1		Reference input 1			

TC37xEXT Pin Definition and Functions LQFP-144 Package Pinning of

Table 2-56 Port 02 Functions (cont'd)

Pin	Symbol	Ctrl.	Buffer Type	Function
7	P02.6	I	FAST / PU1 / VEXT / ES	General-purpose input
	GTM_TIM3_IN0_10			Mux input channel 0 of TIM module 3
	GTM_TIM1_IN6_1			Mux input channel 6 of TIM module 1
	GTM_TIM0_IN6_1			Mux input channel 6 of TIM module 0
	CCU60_CC60INC			T12 capture input 60
	SENT_SENT2C			Receive input channel 2
	EDSADC_DSDIN4B			Digital datastream input, channel 4
	EDSADC_ITR5E			Trigger/Gate input, channel 5
	GPT120_T3INA			Trigger/gate input of core timer T3
	CCU60_CCPOS0A			Hall capture input 0
	CCU61_T12HRB			External timer start 12
	QSPI3_MTSRA			Slave SPI data input
	CIF_D6			sensor pixel data input
	P02.6			O0
	GTM_TOUT6	O1	GTM muxed output	
	IOM_REF0_6		Reference input 0	
	PSI5S_TX	O2	TX data output	
	QSPI3_MTSR	O3	Master SPI data output	
	PSI5_TX1	O4	TXD outputs (send data)	
	IOM_MON1_15		Monitor input 1	
EVADC_EMUX00	O5	Control of external analog multiplexer interface 0		
—	O6	Reserved		
CCU60_CC60	O7	T12 PWM channel 60		
IOM_MON1_2		Monitor input 1		
IOM_REF1_6		Reference input 1		

TC37xEXT Pin Definition and Functions LQFP-144 Package Pinning of

Table 2-56 Port 02 Functions (cont'd)

Pin	Symbol	Ctrl.	Buffer Type	Function
8	P02.7	I	FAST / PU1 / VEXT / ES	General-purpose input
	GTM_TIM3_IN1_10			Mux input channel 1 of TIM module 3
	GTM_TIM1_IN7_1			Mux input channel 7 of TIM module 1
	GTM_TIM0_IN7_1			Mux input channel 7 of TIM module 0
	CCU60_CC61INC			T12 capture input 61
	SENT_SENT1C			Receive input channel 1
	EDSADC_DSCIN3B			Modulator clock input, channel 3
	EDSADC_ITR4E			Trigger/Gate input, channel 4
	GPT120_T3EUDA			Count direction control input of core timer T3
	CCU60_CCPOS1A			Hall capture input 1
	CIF_D7			sensor pixel data input
	QSPI3_SCLKA			Slave SPI clock inputs
	CCU61_T13HRB			External timer start 13
	P02.7			O0
	GTM_TOUT7	O1	GTM muxed output	
	IOM_REF0_7		Reference input 0	
	—	O2	Reserved	
	QSPI3_SCLK	O3	Master SPI clock output	
	EDSADC_DSCOUT3	O4	Modulator clock output	
	EVADC_EMUX01	O5	Control of external analog multiplexer interface 0	
SENT_SPC1	O6	Transmit output		
CCU60_CC61	O7	T12 PWM channel 61		
IOM_MON1_1		Monitor input 1		
IOM_REF1_5		Reference input 1		

TC37xEXT Pin Definition and Functions LQFP-144 Package Pinning of

Table 2-56 Port 02 Functions (cont'd)

Pin	Symbol	Ctrl.	Buffer Type	Function
9	P02.8	I	SLOW / PU1 / VEXT / ES	General-purpose input
	GTM_TIM3_IN2_10			Mux input channel 2 of TIM module 3
	GTM_TIM3_IN0_2			Mux input channel 0 of TIM module 3
	GTM_TIM2_IN0_2			Mux input channel 0 of TIM module 2
	CCU60_CC62INC			T12 capture input 62
	SENT_SENT0C			Receive input channel 0
	CCU60_CCPOS2A			Hall capture input 2
	EDSADC_DSDIN3B			Digital datastream input, channel 3
	EDSADC_ITR3E			Trigger/Gate input, channel 3
	GPT120_T4INA			Trigger/gate input of timer T4
	CCU61_T12HRC			External timer start 12
	CIF_D8			sensor pixel data input
	CCU61_T13HRC			External timer start 13
	GTM_DTMA0_1			CDTM0_DTM4
	P02.8			O0
	GTM_TOUT8	O1	GTM muxed output	
	IOM_REF0_8		Reference input 0	
	QSPI3_SLSO5	O2	Master slave select output	
	ASCLIN8_ASCLK	O3	Shift clock output	
	—	O4	Reserved	
EVADC_EMUX02	O5	Control of external analog multiplexer interface 0		
GETH_MDC	O6	MDIO clock		
CCU60_CC62	O7	T12 PWM channel 62		
IOM_MON1_0		Monitor input 1		
IOM_REF1_4		Reference input 1		

TC37xEXT Pin Definition and Functions LQFP-144 Package Pinning of

Table 2-57 Port 10 Functions

Pin	Symbol	Ctrl.	Buffer Type	Function
140	P10.1	I	FAST / PU1 / VEXT / ES	General-purpose input
	GTM_TIM4_IN4_12			Mux input channel 4 of TIM module 4
	GTM_TIM1_IN1_3			Mux input channel 1 of TIM module 1
	GTM_TIM0_IN1_3			Mux input channel 1 of TIM module 0
	GPT120_T5EUDB			Count direction control input of timer T5
	QSPI1_MRSTA			Master SPI data input
	GTM_DTMT0_1			CDTM0_DTM0
	P10.1	O0	General-purpose output	
	GTM_TOUT103	O1	GTM muxed output	
	QSPI1_MTSR	O2	Master SPI data output	
	QSPI1_MRST	O3	Slave SPI data output	
	IOM_MON2_1		Monitor input 2	
	IOM_REF2_1		Reference input 2	
	MSC0_EN1	O4	Chip Select	
	EVADC_FC1BFLOUT	O5	Boundary flag output, FC channel 1	
	—	O6	Reserved	
	—	O7	Reserved	
141	P10.2	I	FAST / PU1 / VEXT / ES	General-purpose input
	GTM_TIM4_IN5_12			Mux input channel 5 of TIM module 4
	GTM_TIM1_IN2_3			Mux input channel 2 of TIM module 1
	GTM_TIM0_IN2_3			Mux input channel 2 of TIM module 0
	CAN02_RXDE			CAN receive input node 2
	MSC0_SDI1			Upstream assynchronous input signal
	QSPI1_SCLKA			Slave SPI clock inputs
	GPT120_T6INB			Trigger/gate input of core timer T6
	SCU_E_REQ2_0			ERU Channel 2 inputs 0 to 5 (0 is the LSB and 5 is the MSB)
	GTM_DTMT2_2		CDTM2_DTM0	
	P10.2	O0	General-purpose output	
	GTM_TOUT104	O1	GTM muxed output	
	IOM_MON2_9		Monitor input 2	
	—		Reserved	
	QSPI1_SCLK	O3	Master SPI clock output	
	MSC0_EN0	O4	Chip Select	
	EVADC_FC3BFLOUT	O5	Boundary flag output, FC channel 3	
—	O6	Reserved		
—	O7	Reserved		

TC37xEXT Pin Definition and Functions LQFP-144 Package Pinning of

Table 2-57 Port 10 Functions (cont'd)

Pin	Symbol	Ctrl.	Buffer Type	Function
142	P10.3	I	FAST / PU1 / VEXT / ES	General-purpose input
	GTM_TIM4_IN6_10			Mux input channel 6 of TIM module 4
	GTM_TIM1_IN3_3			Mux input channel 3 of TIM module 1
	GTM_TIM0_IN3_3			Mux input channel 3 of TIM module 0
	QSPI1_MTSRA			Slave SPI data input
	SCU_E_REQ3_0			ERU Channel 3 inputs 0 to 5 (0 is the LSB and 5 is the MSB)
	GPT120_T5INB			Trigger/gate input of timer T5
	P10.3			O0
	GTM_TOUT105	O1	GTM muxed output	
	IOM_MON2_10		Monitor input 2	
	—	O2	Reserved	
	QSPI1_MTSR	O3	Master SPI data output	
	MSC0_EN0	O4	Chip Select	
	—	O5	Reserved	
	CAN02_TXD	O6	CAN transmit output node 2	
	IOM_MON2_7		Monitor input 2	
	IOM_REF2_7		Reference input 2	
—	O7	Reserved		
143	P10.5	I	SLOW / PU2 / VEXT / ES	General-purpose input
	GTM_TIM4_IN3_13			Mux input channel 3 of TIM module 4
	GTM_TIM1_IN2_4			Mux input channel 2 of TIM module 1
	GTM_TIM0_IN2_4			Mux input channel 2 of TIM module 0
	PMS_HWCFCG4IN			HWCFCG4 pin input
	CAN20_RXDA			CAN receive input node 0
	MSC0_INJ1			Injection signal from port
	P10.5			O0
	GTM_TOUT107	O1	GTM muxed output	
	IOM_REF2_9		Reference input 2	
	ASCLIN2_ATX	O2	Transmit output	
	IOM_MON2_14		Monitor input 2	
	IOM_REF2_14		Reference input 2	
	QSPI3_SLSO8	O3	Master slave select output	
	QSPI1_SLSO9	O4	Master slave select output	
	GPT120_T6OUT	O5	External output for overflow/underflow detection of core timer T6	
	ASCLIN2_ASLSO	O6	Slave select signal output	
—	O7	Reserved		

TC37xEXT Pin Definition and Functions LQFP-144 Package Pinning of

Table 2-57 Port 10 Functions (cont'd)

Pin	Symbol	Ctrl.	Buffer Type	Function
144	P10.6	I	SLOW / PU2 / VEXT / ES	General-purpose input
	GTM_TIM4_IN2_13			Mux input channel 2 of TIM module 4
	GTM_TIM1_IN3_4			Mux input channel 3 of TIM module 1
	GTM_TIM0_IN3_4			Mux input channel 3 of TIM module 0
	ASCLIN2_ARXD			Receive input
	QSPI3_MTSRB			Slave SPI data input
	PMS_HWC5IN			HWC5 pin input
	P10.6	O0	General-purpose output	
	GTM_TOUT108	O1	GTM muxed output	
	IOM_REF2_10		Reference input 2	
	ASCLIN2_ASCLK	O2	Shift clock output	
	QSPI3_MTSR	O3	Master SPI data output	
	GPT120_T3OUT	O4	External output for overflow/underflow detection of core timer T3	
	CAN20_TXD	O5	CAN transmit output node 0	
	QSPI1_MRST	O6	Slave SPI data output	
	IOM_MON2_1		Monitor input 2	
	IOM_REF2_1		Reference input 2	
—	O7	Reserved		

Table 2-58 Port 11 Functions

Pin	Symbol	Ctrl.	Buffer Type	Function
132	P11.2	I	RFast / PU1 / VFLEX / ES	General-purpose input
	GTM_TIM3_IN1_3			Mux input channel 1 of TIM module 3
	GTM_TIM2_IN1_3			Mux input channel 1 of TIM module 2
	P11.2	O0	General-purpose output	
	GTM_TOUT95	O1	GTM muxed output	
	—	O2	Reserved	
	QSPI0_SLSO5	O3	Master slave select output	
	QSPI1_SLSO5	O4	Master slave select output	
	MSC0_EN1	O5	Chip Select	
	GETH_TXD1	O6	Transmit Data	
	CCU60_COUT63	O7	T13 PWM channel 63	
	IOM_MON1_6		Monitor input 1	
	IOM_REF1_0		Reference input 1	

TC37xEXT Pin Definition and Functions LQFP-144 Package Pinning of

Table 2-58 Port 11 Functions (cont'd)

Pin	Symbol	Ctrl.	Buffer Type	Function	
133	P11.3	I	RFAST / PU1 / VFLEX / ES	General-purpose input	
	GTM_TIM3_IN2_2			Mux input channel 2 of TIM module 3	
	GTM_TIM2_IN2_2			Mux input channel 2 of TIM module 2	
	MSC0_SDI3			Upstream asynchronous input signal	
	QSPI1_MRSTB			Master SPI data input	
	P11.3			O0	General-purpose output
	GTM_TOUT96			O1	GTM muxed output
	—			O2	Reserved
	QSPI1_MRST			O3	Slave SPI data output
	IOM_MON2_1				Monitor input 2
	IOM_REF2_1				Reference input 2
	ERAY0_TXDA			O4	Transmit Channel A
	—			O5	Reserved
	GETH_TXD0			O6	Transmit Data
	CCU60_COUT62			O7	T12 PWM channel 62
	IOM_MON1_5				Monitor input 1
IOM_REF1_1	Reference input 1				
134	P11.6	I	RFAST / PU1 / VFLEX / ES	General-purpose input	
	GTM_TIM3_IN3_2			Mux input channel 3 of TIM module 3	
	GTM_TIM2_IN3_2			Mux input channel 3 of TIM module 2	
	QSPI1_SCLKB			Slave SPI clock inputs	
	P11.6			O0	General-purpose output
	GTM_TOUT97			O1	GTM muxed output
	ERAY0_TXENB			O2	Transmit Enable Channel B
	QSPI1_SCLK			O3	Master SPI clock output
	ERAY0_TXENA			O4	Transmit Enable Channel A
	MSC0_FCLP			O5	Shift-clock direct part of the differential signal
	GETH_TXEN			O6	Transmit Enable MII and RMII
	GETH_TCTL				Transmit Control for RGMII
	CCU60_COUT61			O7	T12 PWM channel 61
	IOM_MON1_4				Monitor input 1
	IOM_REF1_2				Reference input 1

TC37xEXT Pin Definition and Functions LQFP-144 Package Pinning of

Table 2-58 Port 11 Functions (cont'd)

Pin	Symbol	Ctrl.	Buffer Type	Function
135	P11.9	I	FAST / RGMII_Input / PU1 / VFLEX / ES	General-purpose input
	GTM_TIM3_IN4_2			Mux input channel 4 of TIM module 3
	GTM_TIM2_IN4_2			Mux input channel 4 of TIM module 2
	QSPI1_MTSRB			Slave SPI data input
	ERAY0_RXDA1			Receive Channel A1
	GETH_RXD1A			Receive Data 1 MII, RMI and RGMII (RGMII can use RXD1A only)
	P11.9	O0	FAST / RGMII_Input / PU1 / VFLEX / ES	General-purpose output
	GTM_TOUT98	O1		GTM muxed output
	—	O2		Reserved
	QSPI1_MTSR	O3		Master SPI data output
	—	O4		Reserved
	MSC0_SOP	O5		Data output - direct part of the differential signal
	—	O6		Reserved
	CCU60_COUT60	O7		T12 PWM channel 60
	IOM_MON1_3			Monitor input 1
	IOM_REF1_3			Reference input 1

TC37xEXT Pin Definition and Functions LQFP-144 Package Pinning of

Table 2-58 Port 11 Functions (cont'd)

Pin	Symbol	Ctrl.	Buffer Type	Function	
137	P11.10	I	FAST / RGMII_Input / PU1 / VFLEX / ES	General-purpose input	
	GTM_TIM3_IN5_2			Mux input channel 5 of TIM module 3	
	GTM_TIM2_IN5_2			Mux input channel 5 of TIM module 2	
	GTM_TIM2_IN0_9			Mux input channel 0 of TIM module 2	
	CAN03_RXDD			CAN receive input node 3	
	ERAY0_RXDB1			Receive Channel B1	
	ASCLIN1_ARXE			Receive input	
	SCU_E_REQ6_3			ERU Channel 6 inputs 0 to 5 (0 is the LSB and 5 is the MSB)	
	MSC0_SDI0			Upstream asynchronous input signal	
	GETH_RXD0A			Receive Data 0 MII, RMI and RGMII (RGMII can use RXD0A only)	
	QSPI1_SLSIA			Slave select input	
	P11.10			O0	General-purpose output
	GTM_TOUT99			O1	GTM muxed output
—	O2	Reserved			
QSPI0_SLSO3	O3	Master slave select output			
QSPI1_SLSO3	O4	Master slave select output			
—	O5	Reserved			
—	O6	Reserved			
CCU60_CC62	O7	T12 PWM channel 62			
IOM_MON1_0		Monitor input 1			
IOM_REF1_4		Reference input 1			

TC37xEXT Pin Definition and Functions LQFP-144 Package Pinning of

Table 2-58 Port 11 Functions (cont'd)

Pin	Symbol	Ctrl.	Buffer Type	Function
138	P11.11	I	FAST / RGMII_In put / PU1 / VFLEX / ES	General-purpose input
	GTM_TIM3_IN6_2			Mux input channel 6 of TIM module 3
	GTM_TIM3_IN0_14			Mux input channel 0 of TIM module 3
	GTM_TIM2_IN6_2			Mux input channel 6 of TIM module 2
	GETH_CRSDVA			Carrier Sense / Data Valid combi-signal for RMII
	GETH_RXDVA			Receive Data Valid MII
	GETH_CRSB			Carrier Sense MII
	GETH_RCTLA			Receive Control for RGMII
	P11.11	O0	General-purpose output	
	GTM_TOUT100	O1	GTM muxed output	
	—	O2	Reserved	
	QSPIO_SLSO4	O3	Master slave select output	
	QSPI1_SLSO4	O4	Master slave select output	
	MSC0_EN0	O5	Chip Select	
	ERAY0_TXENB	O6	Transmit Enable Channel B	
	CCU60_CC61	O7	T12 PWM channel 61	
	IOM_MON1_1		Monitor input 1	
IOM_REF1_5		Reference input 1		
139	P11.12	I	FAST / RGMII_In put / PU1 / VFLEX / ES	General-purpose input
	GTM_TIM3_IN7_2			Mux input channel 7 of TIM module 3
	GTM_TIM2_IN7_2			Mux input channel 7 of TIM module 2
	GETH_REFCLKA			Reference Clock input for RMII (50 MHz)
	GETH_TXCLKB			Transmit Clock Input for MII
	GETH_RXCLKA			Receive Clock MII
	P11.12	O0	General-purpose output	
	GTM_TOUT101	O1	GTM muxed output	
	ASCLIN1_ATX	O2	Transmit output	
	IOM_MON2_13		Monitor input 2	
	IOM_REF2_13		Reference input 2	
	GTM_CLK2	O3	CGM generated clock	
	ERAY0_TXDB	O4	Transmit Channel B	
	CAN03_TXD	O5	CAN transmit output node 3	
	IOM_MON2_8		Monitor input 2	
	IOM_REF2_8		Reference input 2	
	CCU_EXTCLK1	O6	External Clock 1	
CCU60_CC60	O7	T12 PWM channel 60		
IOM_MON1_2		Monitor input 1		
IOM_REF1_6		Reference input 1		

TC37xEXT Pin Definition and Functions LQFP-144 Package Pinning of

Table 2-59 Port 13 Functions

Pin	Symbol	Ctrl.	Buffer Type	Function
128	P13.0	I	LVDS_TX / FAST / PU1 / VEXT / ES6	General-purpose input
	GTM_TIM3_IN5_3			Mux input channel 5 of TIM module 3
	GTM_TIM2_IN5_3			Mux input channel 5 of TIM module 2
	ASCLIN10_ARXC			Receive input
	P13.0	O0		General-purpose output
	GTM_TOUT91	O1		GTM muxed output
	ASCLIN10_ATX	O2		Transmit output
	QSPI2_SCLKN	O3		Master SPI clock output (LVDS N line)
	MSC0_EN1	O4		Chip Select
	MSC0_FCLN	O5		Shift-clock inverted part of the differential signal
	—	O6		Reserved
	CAN10_TXD	O7		CAN transmit output node 0
129	P13.1	I	LVDS_TX / FAST / PU1 / VEXT / ES6	General-purpose input
	GTM_TIM3_IN6_3			Mux input channel 6 of TIM module 3
	GTM_TIM2_IN6_3			Mux input channel 6 of TIM module 2
	I2C0_SCLB			Serial Clock Input 1
	CAN10_RXDD			CAN receive input node 0
	ASCLIN10_ARXD			Receive input
	P13.1	O0		General-purpose output
	GTM_TOUT92	O1		GTM muxed output
	—	O2		Reserved
	QSPI2_SCLKP	O3		Master SPI clock output (LVDS P line)
	—	O4		Reserved
	MSC0_FCLP	O5		Shift-clock direct part of the differential signal
	I2C0_SCL	O6		Serial Clock Output
	—	O7		Reserved

TC37xEXT Pin Definition and Functions LQFP-144 Package Pinning of

Table 2-59 Port 13 Functions (cont'd)

Pin	Symbol	Ctrl.	Buffer Type	Function
130	P13.2	I	LVDS_TX / FAST / PU1 / VEXT / ES6	General-purpose input
	GTM_TIM3_IN7_3			Mux input channel 7 of TIM module 3
	GTM_TIM2_IN7_3			Mux input channel 7 of TIM module 2
	GPT120_CAPINA			Trigger input to capture value of timer T5 into CAPREL register
	I2C0_SDAB			Serial Data Input 1
	P13.2	O0	General-purpose output	
	GTM_TOUT93	O1	GTM muxed output	
	ASCLIN10_ASCLK	O2	Shift clock output	
	QSPI2_MTSRN	O3	Master SPI data output (LVDS N line)	
	MSC0_FCLP	O4	Shift-clock direct part of the differential signal	
	MSC0_SON	O5	Data output - inverted part of the differential signal	
	I2C0_SDA	O6	Serial Data Output	
	—	O7	Reserved	
131	P13.3	I	LVDS_TX / FAST / PU1 / VEXT / ES6	General-purpose input
	GTM_TIM3_IN0_3			Mux input channel 0 of TIM module 3
	GTM_TIM2_IN0_3			Mux input channel 0 of TIM module 2
	P13.3	O0	General-purpose output	
	GTM_TOUT94	O1	GTM muxed output	
	ASCLIN10_ASLSO	O2	Slave select signal output	
	QSPI2_MTSRP	O3	Master SPI data output (LVDS P line)	
	—	O4	Reserved	
	MSC0_SOP	O5	Data output - direct part of the differential signal	
	—	O6	Reserved	
	—	O7	Reserved	

TC37xEXT Pin Definition and Functions LQFP-144 Package Pinning of

Table 2-60 Port 14 Functions

Pin	Symbol	Ctrl.	Buffer Type	Function
118	P14.0	I	FAST / PU1 / VEXT / ES2	General-purpose input
	GTM_TIM1_IN3_5			Mux input channel 3 of TIM module 1
	GTM_TIM0_IN3_5			Mux input channel 3 of TIM module 0
	P14.0	O0		General-purpose output
	GTM_TOUT80	O1		GTM muxed output
	ASCLIN0_ATX	O2		Transmit output
	IOM_MON2_12			Monitor input 2
	IOM_REF2_12			Reference input 2
	ERAY0_TXDA	O3		Transmit Channel A
	ERAY0_TXDB	O4		Transmit Channel B
	CAN01_TXD	O5		CAN transmit output node 1
	IOM_MON2_6			Monitor input 2
	IOM_REF2_6			Reference input 2
	ASCLIN0_ASCLK	O6		Shift clock output
	CCU60_COUT62	O7		T12 PWM channel 62
	IOM_MON1_5			Monitor input 1
IOM_REF1_1	Reference input 1			

TC37xEXT Pin Definition and Functions LQFP-144 Package Pinning of

Table 2-60 Port 14 Functions (cont'd)

Pin	Symbol	Ctrl.	Buffer Type	Function
119	P14.1	I	FAST / PU1 / VEXT / ES2	General-purpose input
	GTM_TIM1_IN4_3			Mux input channel 4 of TIM module 1
	GTM_TIM0_IN4_3			Mux input channel 4 of TIM module 0
	ERAY0_RXDA3			Receive Channel A3
	ASCLIN0_ARXA			Receive input
	ERAY0_RXDB3			Receive Channel B3
	CAN01_RXDB			CAN receive input node 1
	SCU_E_REQ3_1			ERU Channel 3 inputs 0 to 5 (0 is the LSB and 5 is the MSB)
	PMS_PINAWKP			PINA (P14.1) pin input
	P14.1			O0
	GTM_TOUT81	O1	GTM muxed output	
	ASCLIN0_ATX	O2	Transmit output	
	IOM_MON2_12		Monitor input 2	
	IOM_REF2_12		Reference input 2	
	—		Reserved	
	—	O3	Reserved	
	—	O4	Reserved	
	—	O5	Reserved	
	—	O6	Reserved	
	CCU60_COUT63	O7	T13 PWM channel 63	
IOM_MON1_6		Monitor input 1		
IOM_REF1_0		Reference input 1		
120	P14.2	I	SLOW / PU2 / VEXT / ES	General-purpose input
	GTM_TIM1_IN5_3			Mux input channel 5 of TIM module 1
	GTM_TIM0_IN5_3			Mux input channel 5 of TIM module 0
	PMS_HWCFG2IN			HWCFG2 pin input
	P14.2	O0	General-purpose output	
	GTM_TOUT82	O1	GTM muxed output	
	ASCLIN2_ATX	O2	Transmit output	
	IOM_MON2_14		Monitor input 2	
	IOM_REF2_14		Reference input 2	
	QSPI2_SLSO1		O3	Master slave select output
	—	O4	Reserved	
	—	O5	Reserved	
	ASCLIN2_ASCLK	O6	Shift clock output	
	—	O7	Reserved	

TC37xEXT Pin Definition and Functions LQFP-144 Package Pinning of

Table 2-60 Port 14 Functions (cont'd)

Pin	Symbol	Ctrl.	Buffer Type	Function
121	P14.3	I	SLOW / PU2 / VEXT / ES	General-purpose input
	GTM_TIM1_IN6_3			Mux input channel 6 of TIM module 1
	GTM_TIM0_IN6_3			Mux input channel 6 of TIM module 0
	PMS_HWCFG3IN			HWCFG3 pin input
	ASCLIN2_ARXA			Receive input
	MSC0_SDI2			Upstream assynchronous input signal
	SCU_E_REQ1_0			ERU Channel 1 inputs 0 to 5 (0 is the LSB and 5 is the MSB)
	P14.3	O0	General-purpose output	
	GTM_TOUT83	O1	GTM muxed output	
	ASCLIN2_ATX	O2	Transmit output	
	IOM_MON2_14		Monitor input 2	
	IOM_REF2_14		Reference input 2	
	QSPI2_SLSO3	O3	Master slave select output	
	ASCLIN1_ASLSO	O4	Slave select signal output	
	ASCLIN3_ASLSO	O5	Slave select signal output	
	—	O6	Reserved	
	—	O7	Reserved	
122	P14.4	I	SLOW / PU2 / VEXT / ES	General-purpose input
	GTM_TIM1_IN7_2			Mux input channel 7 of TIM module 1
	GTM_TIM0_IN7_2			Mux input channel 7 of TIM module 0
	PMS_HWCFG6IN			HWCFG6 pin input
	GTM_DTMT0_0			CDTM0_DTM0
	P14.4	O0	General-purpose output	
	GTM_TOUT84	O1	GTM muxed output	
	—	O2	Reserved	
	—	O3	Reserved	
	—	O4	Reserved	
	—	O5	Reserved	
	GETH_PPS	O6	Pulse Per Second	
	—	O7	Reserved	

TC37xEXT Pin Definition and Functions LQFP-144 Package Pinning of

Table 2-60 Port 14 Functions (cont'd)

Pin	Symbol	Ctrl.	Buffer Type	Function
123	P14.5	I	FAST / PU2 / VEXT / ES	General-purpose input
	GTM_TIM1_IN0_4			Mux input channel 0 of TIM module 1
	GTM_TIM0_IN0_4			Mux input channel 0 of TIM module 0
	PMS_HWCFG1IN			HWCFG1 pin input
	GTM_DTMA2_0			CDTM2_DTM4
	P14.5			O0
	GTM_TOUT85	O1	GTM muxed output	
	—	O2	Reserved	
	—	O3	Reserved	
	—	O4	Reserved	
	—	O5	Reserved	
	ERAY0_TXDB	O6	Transmit Channel B	
	—	O7	Reserved	
124	P14.6	I	FAST / PU1 / VEXT / ES	General-purpose input
	GTM_TIM1_IN1_4			Mux input channel 1 of TIM module 1
	GTM_TIM0_IN1_4			Mux input channel 1 of TIM module 0
	P14.6	O0	General-purpose output	
	GTM_TOUT86	O1	GTM muxed output	
	—	O2	Reserved	
	QSPI2_SLSO2	O3	Master slave select output	
	CAN13_TXD	O4	CAN transmit output node 3	
	—	O5	Reserved	
	ERAY0_TXENB	O6	Transmit Enable Channel B	
	—	O7	Reserved	

TC37xEXT Pin Definition and Functions LQFP-144 Package Pinning of

Table 2-61 Port 15 Functions

Pin	Symbol	Ctrl.	Buffer Type	Function	
109	P15.0	I	FAST / PU1 / VEXT / ES	General-purpose input	
	GTM_TIM3_IN3_4			Mux input channel 3 of TIM module 3	
	GTM_TIM2_IN3_4			Mux input channel 3 of TIM module 2	
	SDMMC0_DAT7_IN			read data in	
	P15.0			O0	General-purpose output
	GTM_TOUT71			O1	GTM muxed output
	ASCLIN1_ATX			O2	Transmit output
	IOM_MON2_13				Monitor input 2
	IOM_REF2_13				Reference input 2
	QSPI0_SLSO13			O3	Master slave select output
	—			O4	Reserved
	CAN02_TXD			O5	CAN transmit output node 2
	IOM_MON2_7			O6	Monitor input 2
	IOM_REF2_7				Reference input 2
	ASCLIN1_ASCLK	O6	Shift clock output		
—	O7	Reserved			
SDMMC0_DAT7	O	write data out			
110	P15.1	I	FAST / PU1 / VEXT / ES	General-purpose input	
	GTM_TIM3_IN4_4			Mux input channel 4 of TIM module 3	
	GTM_TIM2_IN4_4			Mux input channel 4 of TIM module 2	
	CAN02_RXDA			CAN receive input node 2	
	ASCLIN1_ARXA			Receive input	
	QSPI2_SLSIB			Slave select input	
	SCU_E_REQ7_2			ERU Channel 7 inputs 0 to 5 (0 is the LSB and 5 is the MSB)	
	P15.1			O0	General-purpose output
	GTM_TOUT72			O1	GTM muxed output
	ASCLIN1_ATX			O2	Transmit output
	IOM_MON2_13				Monitor input 2
	IOM_REF2_13				Reference input 2
	QSPI2_SLSO5			O3	Master slave select output
	—			O4	Reserved
	—	O5	Reserved		
—	O6	Reserved			
SDMMC0_CLK	O7	card clock			

TC37xEXT Pin Definition and Functions LQFP-144 Package Pinning of

Table 2-61 Port 15 Functions (cont'd)

Pin	Symbol	Ctrl.	Buffer Type	Function	
111	P15.2	I	FAST / PU1 / VEXT / ES	General-purpose input	
	GTM_TIM3_IN5_4			Mux input channel 5 of TIM module 3	
	GTM_TIM2_IN5_4			Mux input channel 5 of TIM module 2	
	QSPI2_SLSIA			Slave select input	
	SENT_SENT10D			Receive input channel 10	
	QSPI2_MRSTE			Master SPI data input	
	P15.2	O0	FAST / PU1 / VEXT / ES	General-purpose output	
	GTM_TOUT73	O1		GTM muxed output	
	ASCLIN0_ATX	O2		Transmit output	
	IOM_MON2_12			Monitor input 2	
	IOM_REF2_12			Reference input 2	
	QSPI2_SLSO0	O3		Master slave select output	
	—	O4		Reserved	
	CAN01_TXD	O5		CAN transmit output node 1	
	IOM_MON2_6			Monitor input 2	
	IOM_REF2_6			Reference input 2	
	ASCLIN0_ASCLK	O6		Shift clock output	
	—	O7		Reserved	
	112	P15.3		I	FAST / PU1 / VEXT / ES
GTM_TIM3_IN6_4		Mux input channel 6 of TIM module 3			
GTM_TIM2_IN6_4		Mux input channel 6 of TIM module 2			
CAN01_RXDA		CAN receive input node 1			
ASCLIN0_ARXB		Receive input			
QSPI2_SCLKA		Slave SPI clock inputs			
SDMMC0_CMD_IN		command in			
P15.3		O0	FAST / PU1 / VEXT / ES	General-purpose output	
GTM_TOUT74		O1		GTM muxed output	
ASCLIN0_ATX		O2		Transmit output	
IOM_MON2_12				Monitor input 2	
IOM_REF2_12				Reference input 2	
QSPI2_SCLK		O3		Master SPI clock output	
—		O4		Reserved	
MSC0_EN1		O5		Chip Select	
—		O6		Reserved	
—		O7		Reserved	
SDMMC0_CMD		O		command out	

TC37xEXT Pin Definition and Functions LQFP-144 Package Pinning of

Table 2-61 Port 15 Functions (cont'd)

Pin	Symbol	Ctrl.	Buffer Type	Function
113	P15.4	I	FAST / PU1 / VEXT / ES	General-purpose input
	GTM_TIM3_IN7_4			Mux input channel 7 of TIM module 3
	GTM_TIM2_IN7_4			Mux input channel 7 of TIM module 2
	I2C0_SCLC			Serial Clock Input 2
	QSPI2_MRSTA			Master SPI data input
	SCU_E_REQ0_0			ERU Channel 0 inputs 0 to 5 (0 is the LSB and 5 is the MSB)
	SENT_SENT11D			Receive input channel 11
	P15.4			O0
	GTM_TOUT75	O1	GTM muxed output	
	ASCLIN1_ATX	O2	Transmit output	
	IOM_MON2_13		Monitor input 2	
	IOM_REF2_13		Reference input 2	
	QSPI2_MRST	O3	Slave SPI data output	
	IOM_MON2_2		Monitor input 2	
	IOM_REF2_2		Reference input 2	
	—	O4	Reserved	
	—	O5	Reserved	
	I2C0_SCL	O6	Serial Clock Output	
	CCU60_CC62	O7	T12 PWM channel 62	
	IOM_MON1_0		Monitor input 1	
IOM_REF1_4	Reference input 1			

TC37xEXT Pin Definition and Functions LQFP-144 Package Pinning of

Table 2-61 Port 15 Functions (cont'd)

Pin	Symbol	Ctrl.	Buffer Type	Function	
114	P15.5	I	FAST / PU1 / VEXT / ES	General-purpose input	
	GTM_TIM3_IN0_4			Mux input channel 0 of TIM module 3	
	GTM_TIM2_IN0_4			Mux input channel 0 of TIM module 2	
	ASCLIN1_ARXB			Receive input	
	I2C0_SDAC			Serial Data Input 2	
	QSPI2_MTSRA			Slave SPI data input	
	SCU_E_REQ4_3			ERU Channel 4 inputs 0 to 5 (0 is the LSB and 5 is the MSB)	
	P15.5			O0	General-purpose output
	GTM_TOUT76			O1	GTM muxed output
	ASCLIN1_ATX			O2	Transmit output
	IOM_MON2_13				Monitor input 2
	IOM_REF2_13				Reference input 2
	QSPI2_MTSR			O3	Master SPI data output
	—			O4	Reserved
	MSC0_EN0			O5	Chip Select
	I2C0_SDA			O6	Serial Data Output
	CCU60_CC61			O7	T12 PWM channel 61
IOM_MON1_1		Monitor input 1			
IOM_REF1_5		Reference input 1			
115	P15.6	I	FAST / PU1 / VEXT / ES	General-purpose input	
	GTM_TIM2_IN2_14			Mux input channel 2 of TIM module 2	
	GTM_TIM1_IN0_6			Mux input channel 0 of TIM module 1	
	GTM_TIM0_IN0_6			Mux input channel 0 of TIM module 0	
	QSPI2_MTSRB			Slave SPI data input	
	P15.6			O0	General-purpose output
	GTM_TOUT77			O1	GTM muxed output
	ASCLIN3_ATX			O2	Transmit output
	IOM_MON2_15				Monitor input 2
	IOM_REF2_15				Reference input 2
	QSPI2_MTSR			O3	Master SPI data output
	—			O4	Reserved
	QSPI2_SCLK			O5	Master SPI clock output
	ASCLIN3_ASCLK			O6	Shift clock output
	CCU60_CC60			O7	T12 PWM channel 60
IOM_MON1_2		Monitor input 1			
IOM_REF1_6		Reference input 1			

TC37xEXT Pin Definition and Functions LQFP-144 Package Pinning of

Table 2-61 Port 15 Functions (cont'd)

Pin	Symbol	Ctrl.	Buffer Type	Function	
116	P15.7	I	FAST / PU1 / VEXT / ES	General-purpose input	
	GTM_TIM1_IN1_5			Mux input channel 1 of TIM module 1	
	GTM_TIM0_IN1_5			Mux input channel 1 of TIM module 0	
	ASCLIN3_ARXA			Receive input	
	QSPI2_MRSTB			Master SPI data input	
	P15.7			O0	General-purpose output
	GTM_TOUT78			O1	GTM muxed output
	ASCLIN3_ATX			O2	Transmit output
	IOM_MON2_15			O3	Monitor input 2
	IOM_REF2_15				Reference input 2
	QSPI2_MRST				Slave SPI data output
	IOM_MON2_2				Monitor input 2
	IOM_REF2_2			Reference input 2	
	—			O4	Reserved
	—			O5	Reserved
	—			O6	Reserved
CCU60_COUT60	O7	T12 PWM channel 60			
IOM_MON1_3		Monitor input 1			
IOM_REF1_3		Reference input 1			
117	P15.8	I	FAST / PU1 / VEXT / ES	General-purpose input	
	GTM_TIM1_IN2_5			Mux input channel 2 of TIM module 1	
	GTM_TIM0_IN2_5			Mux input channel 2 of TIM module 0	
	QSPI2_SCLKB			Slave SPI clock inputs	
	SCU_E_REQ5_0			ERU Channel 5 inputs 0 to 5 (0 is the LSB and 5 is the MSB)	
	P15.8			O0	General-purpose output
	GTM_TOUT79			O1	GTM muxed output
	—			O2	Reserved
	QSPI2_SCLK			O3	Master SPI clock output
	—			O4	Reserved
	—			O5	Reserved
	ASCLIN3_ASCLK			O6	Shift clock output
	CCU60_COUT61			O7	T12 PWM channel 61
	IOM_MON1_4				Monitor input 1
IOM_REF1_2	Reference input 1				

TC37xEXT Pin Definition and Functions LQFP-144 Package Pinning of

Table 2-62 Port 20 Functions

Pin	Symbol	Ctrl.	Buffer Type	Function
93	P20.0	I	FAST / PU1 / VEXT / ES	General-purpose input
	GTM_TIM1_IN6_7			Mux input channel 6 of TIM module 1
	GTM_TIM1_IN4_9			Mux input channel 4 of TIM module 1
	GTM_TIM0_IN6_7			Mux input channel 6 of TIM module 0
	CAN03_RXDC			CAN receive input node 3
	CCU_PAD_SYSCLK			Sysclk input
	CAN21_RXDC			CAN receive input node 1
	CBS_TGI0			Trigger input
	SCU_E_REQ6_0			ERU Channel 6 inputs 0 to 5 (0 is the LSB and 5 is the MSB)
	GPT120_T6EUDA			Count direction control input of core timer T6
	P20.0	O0	General-purpose output	
	GTM_TOUT59	O1	GTM muxed output	
	ASCLIN3_ATX	O2	Transmit output	
	IOM_MON2_15		Monitor input 2	
	IOM_REF2_15		Reference input 2	
	ASCLIN3_ASCLK	O3	Shift clock output	
	—	O4	Reserved	
	HSCT0_SYSCLK_OUT	O5	sys clock output	
	—	O6	Reserved	
	—	O7	Reserved	
CBS_TGO0	O	Trigger output		
94	P20.2	I	S / PU / VEXT	General-purpose input This pin is latched at power on reset release to enter test mode.
	TESTMODE			Testmode Enable Input

TC37xEXT Pin Definition and Functions LQFP-144 Package Pinning of

Table 2-62 Port 20 Functions (cont'd)

Pin	Symbol	Ctrl.	Buffer Type	Function
95	P20.3	I	SLOW / PU1 / VEXT / ES	General-purpose input
	GTM_TIM4_IN5_11			Mux input channel 5 of TIM module 4
	GTM_TIM3_IN4_5			Mux input channel 4 of TIM module 3
	GTM_TIM2_IN4_5			Mux input channel 4 of TIM module 2
	ASCLIN3_ARXC			Receive input
	GPT120_T6INA			Trigger/gate input of core timer T6
	P20.3			O0
	GTM_TOUT61	O1	GTM muxed output	
	ASCLIN3_ATX	O2	Transmit output	
	IOM_MON2_15		Monitor input 2	
	IOM_REF2_15	O3	Reference input 2	
	QSPI0_SLSO9		Master slave select output	
	QSPI2_SLSO9	O4	Master slave select output	
	CAN03_TXD	O5	CAN transmit output node 3	
	IOM_MON2_8		Monitor input 2	
	IOM_REF2_8		Reference input 2	
	CAN21_TXD	O6	CAN transmit output node 1	
	—	O7	Reserved	
	100	P20.6	I	SLOW / PU1 / VEXT / ES
GTM_TIM3_IN6_5		Mux input channel 6 of TIM module 3		
GTM_TIM2_IN6_5		Mux input channel 6 of TIM module 2		
CAN12_RXDA		CAN receive input node 2		
ASCLIN9_ARXE		Receive input		
P20.6		O0	General-purpose output	
GTM_TOUT62		O1	GTM muxed output	
ASCLIN1_ARTS		O2	Ready to send output	
QSPI0_SLSO8		O3	Master slave select output	
QSPI2_SLSO8		O4	Master slave select output	
—		O5	Reserved	
—		O6	Reserved	
—		O7	Reserved	

TC37xEXT Pin Definition and Functions LQFP-144 Package Pinning of

Table 2-62 Port 20 Functions (cont'd)

Pin	Symbol	Ctrl.	Buffer Type	Function
101	P20.7	I	FAST / PU1 / VEXT / ES	General-purpose input
	GTM_TIM3_IN7_5			Mux input channel 7 of TIM module 3
	GTM_TIM2_IN7_5			Mux input channel 7 of TIM module 2
	GTM_TIM1_IN5_8			Mux input channel 5 of TIM module 1
	CAN00_RXDB			CAN receive input node 0
	ASCLIN1_ACTSA			Clear to send input
	ASCLIN9_ARXF			Receive input
	SDMMC0_DAT0_IN			read data in
	P20.7			O0
	GTM_TOUT63	O1	GTM muxed output	
	ASCLIN9_ATX	O2	Transmit output	
	—	O3	Reserved	
	—	O4	Reserved	
	CAN12_TXD	O5	CAN transmit output node 2	
	—	O6	Reserved	
	CCU61_COUT63	O7	T13 PWM channel 63	
	IOM_MON1_7	O	Monitor input 1	
	IOM_REF1_7		Reference input 1	
	SDMMC0_DAT0	O	write data out	
102	P20.8	I	FAST / PU1 / VEXT / ES	General-purpose input
	GTM_TIM1_IN7_3			Mux input channel 7 of TIM module 1
	GTM_TIM0_IN7_3			Mux input channel 7 of TIM module 0
	SDMMC0_DAT1_IN			read data in
	P20.8	O0	General-purpose output	
	GTM_TOUT64	O1	GTM muxed output	
	ASCLIN1_ASLSO	O2	Slave select signal output	
	QSPI0_SLSO0	O3	Master slave select output	
	QSPI1_SLSO0	O4	Master slave select output	
	CAN00_TXD	O5	CAN transmit output node 0	
	IOM_MON2_5	O	Monitor input 2	
	IOM_REF2_5		Reference input 2	
	—		Reserved	
	CCU61_CC60	O7	T12 PWM channel 60	
	IOM_MON1_8	O	Monitor input 1	
	IOM_REF1_13		Reference input 1	
	SDMMC0_DAT1	O	write data out	

TC37xEXT Pin Definition and Functions LQFP-144 Package Pinning of

Table 2-62 Port 20 Functions (cont'd)

Pin	Symbol	Ctrl.	Buffer Type	Function	
103	P20.9	I	FAST / PU1 / VEXT / ES	General-purpose input	
	GTM_TIM3_IN5_5			Mux input channel 5 of TIM module 3	
	GTM_TIM2_IN5_5			Mux input channel 5 of TIM module 2	
	CAN03_RXDE			CAN receive input node 3	
	ASCLIN1_ARXC			Receive input	
	QSPIO_SLSIB			Slave select input	
	SCU_E_REQ7_0			ERU Channel 7 inputs 0 to 5 (0 is the LSB and 5 is the MSB)	
	P20.9			O0	General-purpose output
	GTM_TOUT65			O1	GTM muxed output
	—			O2	Reserved
	QSPIO_SLSO1			O3	Master slave select output
	QSPI1_SLSO1			O4	Master slave select output
	—			O5	Reserved
	—			O6	Reserved
	CCU61_CC61			O7	T12 PWM channel 61
	IOM_MON1_9				Monitor input 1
IOM_REF1_12		Reference input 1			
104	P20.10	I	FAST / PU1 / VEXT / ES	General-purpose input	
	GTM_TIM3_IN6_6			Mux input channel 6 of TIM module 3	
	GTM_TIM2_IN6_6			Mux input channel 6 of TIM module 2	
	SDMMC0_DAT2_IN			read data in	
	P20.10			O0	General-purpose output
	GTM_TOUT66			O1	GTM muxed output
	ASCLIN1_ATX			O2	Transmit output
	IOM_MON2_13				Monitor input 2
	IOM_REF2_13				Reference input 2
	QSPIO_SLSO6			O3	Master slave select output
	QSPI2_SLSO7			O4	Master slave select output
	CAN03_TXD			O5	CAN transmit output node 3
	IOM_MON2_8				Monitor input 2
	IOM_REF2_8				Reference input 2
	ASCLIN1_ASCLK			O6	Shift clock output
	CCU61_CC62			O7	T12 PWM channel 62
	IOM_MON1_10				Monitor input 1
	IOM_REF1_11				Reference input 1
SDMMC0_DAT2	O	write data out			

TC37xEXT Pin Definition and Functions LQFP-144 Package Pinning of

Table 2-62 Port 20 Functions (cont'd)

Pin	Symbol	Ctrl.	Buffer Type	Function
105	P20.11	I	FAST / PU1 / VEXT / ES	General-purpose input
	GTM_TIM3_IN7_6			Mux input channel 7 of TIM module 3
	GTM_TIM2_IN7_6			Mux input channel 7 of TIM module 2
	QSPIO_SCLKA			Slave SPI clock inputs
	SDMMC0_DAT3_IN			read data in
	P20.11	O0		General-purpose output
	GTM_TOUT67	O1		GTM muxed output
	—	O2		Reserved
	QSPIO_SCLK	O3		Master SPI clock output
	—	O4		Reserved
	—	O5		Reserved
	—	O6		Reserved
	CCU61_COUT60	O7		T12 PWM channel 60
	IOM_MON1_11			Monitor input 1
	IOM_REF1_10			Reference input 1
SDMMC0_DAT3	O	write data out		
106	P20.12	I	FAST / PU1 / VEXT / ES	General-purpose input
	GTM_TIM3_IN0_5			Mux input channel 0 of TIM module 3
	GTM_TIM2_IN0_5			Mux input channel 0 of TIM module 2
	QSPIO_MRSTA			Master SPI data input
	SDMMC0_DAT4_IN			read data in
	IOM_PIN_13	GPIO pad input to FPC		
	P20.12	O0		General-purpose output
	GTM_TOUT68	O1		GTM muxed output
	IOM_MON0_13	O2		Monitor input 0
	—			Reserved
	QSPIO_MRST			Slave SPI data output
	IOM_MON2_0	O3		Monitor input 2
	IOM_REF2_0			Reference input 2
	QSPIO_MTSR	O4		Master SPI data output
	—	O5		Reserved
	—	O6		Reserved
	CCU61_COUT61	O7		T12 PWM channel 61
	IOM_MON1_12			Monitor input 1
IOM_REF1_9	Reference input 1			
SDMMC0_DAT4	O	write data out		

TC37xEXT Pin Definition and Functions LQFP-144 Package Pinning of

Table 2-62 Port 20 Functions (cont'd)

Pin	Symbol	Ctrl.	Buffer Type	Function
107	P20.13	I	FAST / PU1 / VEXT / ES	General-purpose input
	GTM_TIM3_IN1_4			Mux input channel 1 of TIM module 3
	GTM_TIM2_IN1_4			Mux input channel 1 of TIM module 2
	QSPIO_SLSIA			Slave select input
	SDMMC0_DAT5_IN			read data in
	IOM_PIN_14			GPIO pad input to FPC
	P20.13			O0
	GTM_TOUT69	O1	GTM muxed output	
	IOM_MON0_14	O2	Monitor input 0	
	—		Reserved	
	QSPIO_SLSO2		Master slave select output	
	QSPIO_SLSO2	O4	Master slave select output	
	QSPIO_SCLK	O5	Master SPI clock output	
	—	O6	Reserved	
	CCU61_COUT62	O7	T12 PWM channel 62	
	IOM_MON1_13	O	Monitor input 1	
	IOM_REF1_8		Reference input 1	
	SDMMC0_DAT5		write data out	
	108	P20.14	I	FAST / PU1 / VEXT / ES
GTM_TIM3_IN2_4		Mux input channel 2 of TIM module 3		
GTM_TIM2_IN2_4		Mux input channel 2 of TIM module 2		
QSPIO_MTSRA		Slave SPI data input		
SDMMC0_DAT6_IN		read data in		
IOM_PIN_15		GPIO pad input to FPC		
DMU_FDEST		Enter destructive debug mode		
P20.14		O0	General-purpose output	
GTM_TOUT70		O1	GTM muxed output	
IOM_MON0_15		O2	Monitor input 0	
—			Reserved	
QSPIO_MTSR			Master SPI data output	
—		O4	Reserved	
—		O5	Reserved	
—		O6	Reserved	
—		O7	Reserved	
SDMMC0_DAT6		O	write data out	

TC37xEXT Pin Definition and Functions LQFP-144 Package Pinning of

Table 2-63 Port 21 Functions

Pin	Symbol	Ctrl.	Buffer Type	Function
84	P21.2	I	LVDS_RX / FAST / PU1 / VEXT / ES	General-purpose input
	GTM_TIM5_IN4_11			Mux input channel 4 of TIM module 5
	GTM_TIM1_IN0_7			Mux input channel 0 of TIM module 1
	GTM_TIM0_IN0_7			Mux input channel 0 of TIM module 0
	QSPI2_MRSTCN			Master SPI data input (LVDS N line)
	SCU_EMGSTOP_PORT_B			Emergency stop Port Pin B input request
	ASCLIN3_ARXGN			Differential Receive input (low active)
	HSCT0_RXDN			Rx data
	QSPI4_MRSTCN			Master SPI data input (LVDS N line)
	ASCLIN11_ARXE			Receive input
	GTM_DTMA1_0			CDTM1_DTM4
	P21.2			O0
	GTM_TOUT53	O1	GTM muxed output	
	ASCLIN3_ASLSO	O2	Slave select signal output	
	—	O3	Reserved	
	—	O4	Reserved	
	GETH_MDC	O5	MDIO clock	
	—	O6	Reserved	
	—	O7	Reserved	

TC37xEXT Pin Definition and Functions LQFP-144 Package Pinning of

Table 2-63 Port 21 Functions (cont'd)

Pin	Symbol	Ctrl.	Buffer Type	Function
85	P21.3	I	LVDS_RX / FAST / PU1 / VEXT / ES	General-purpose input
	GTM_TIM5_IN5_12			Mux input channel 5 of TIM module 5
	GTM_TIM1_IN1_6			Mux input channel 1 of TIM module 1
	GTM_TIM0_IN1_6			Mux input channel 1 of TIM module 0
	QSPI2_MRSTCP			Master SPI data input (LVDS P line)
	ASCLIN3_ARXGP			Differential Receive input (high active)
	GETH_MDIOD			MDIO Input
	HSCT0_RXDP			Rx data
	QSPI4_MRSTCP			Master SPI data input (LVDS P line)
	P21.3			O0
	GTM_TOUT54	O1	GTM muxed output	
	ASCLIN11_ASCLK	O2	Shift clock output	
	—	O3	Reserved	
	—	O4	Reserved	
	—	O5	Reserved	
	—	O6	Reserved	
	—	O7	Reserved	
	GETH_MDIO	O	MDIO Output	
	86	P21.4	I	LVDS_TX / FAST / PU1 / VEXT / ES6
GTM_TIM5_IN6_12		Mux input channel 6 of TIM module 5		
GTM_TIM1_IN2_6		Mux input channel 2 of TIM module 1		
GTM_TIM0_IN2_6		Mux input channel 2 of TIM module 0		
P21.4		O0	General-purpose output	
GTM_TOUT55		O1	GTM muxed output	
ASCLIN11_ASLSO		O2	Slave select signal output	
—		O3	Reserved	
—		O4	Reserved	
—		O5	Reserved	
—		O6	Reserved	
—		O7	Reserved	
HSCT0_TXDN		O	Tx data	

TC37xEXT Pin Definition and Functions LQFP-144 Package Pinning of

Table 2-63 Port 21 Functions (cont'd)

Pin	Symbol	Ctrl.	Buffer Type	Function
87	P21.5	I	LVDS_TX / FAST / PU1 / VEXT / ES6	General-purpose input
	GTM_TIM5_IN7_11			Mux input channel 7 of TIM module 5
	GTM_TIM1_IN3_6			Mux input channel 3 of TIM module 1
	GTM_TIM0_IN3_6			Mux input channel 3 of TIM module 0
	ASCLIN11_ARXF			Receive input
	P21.5	O0		General-purpose output
	GTM_TOUT56	O1		GTM muxed output
	ASCLIN3_ASCLK	O2		Shift clock output
	ASCLIN11_ATX	O3		Transmit output
	—	O4		Reserved
	—	O5		Reserved
	—	O6		Reserved
	—	O7		Reserved
HSC0_TXDP	O	Tx data		
88	P21.6/TDI	I	FAST / PD / PU2 / VEXT / ES3	General-purpose input PD during Reset and in DAP/DAPE or JTAG mode. After Reset release and when not in DAP/DAPE or JTAG mode: PU. In Standby mode: HighZ. DAPE: DAPE1 Data I/O.
	GTM_TIM4_IN2_12			Mux input channel 2 of TIM module 4
	GTM_TIM1_IN4_8			Mux input channel 4 of TIM module 1
	GTM_TIM0_IN4_8			Mux input channel 4 of TIM module 0
	GPT120_T5EUDA			Count direction control input of timer T5
	ASCLIN3_ARXF			Receive input
	CBS_TGI2			Trigger input
	TDI	JTAG Module Data Input		
	P21.6	O0		General-purpose output
	GTM_TOUT57	O1		GTM muxed output
	ASCLIN3_ASLSO	O2		Slave select signal output
	—	O3		Reserved
	—	O4		Reserved
	—	O5		Reserved
	—	O6		Reserved
	GPT120_T3OUT	O7		External output for overflow/underflow detection of core timer T3
	CBS_TGO2	O		Trigger output
DAP3	I/O	DAP: DAP3 Data I/O		
DAPE1	I/O	DAPE: DAPE1 Data I/O		

TC37xEXT Pin Definition and Functions LQFP-144 Package Pinning of

Table 2-63 Port 21 Functions (cont'd)

Pin	Symbol	Ctrl.	Buffer Type	Function	
90	P21.7/TDO	I	FAST / PU2 / VEXT / ES4	General-purpose input DAP: DAP2 Data I/O; DAPE: DAPE2 Data I/O.	
	GTM_TIM4_IN3_12			Mux input channel 3 of TIM module 4	
	GTM_TIM1_IN5_7			Mux input channel 5 of TIM module 1	
	GTM_TIM0_IN5_7			Mux input channel 5 of TIM module 0	
	GPT120_T5INA			Trigger/gate input of timer T5	
	CBS_TGI3			Trigger input	
	GETH_RXERB			Receive Error MII	
	P21.7			O0	General-purpose output
	GTM_TOUT58			O1	GTM muxed output
	ASCLIN3_ATX			O2	Transmit output
	IOM_MON2_15				Monitor input 2
	IOM_REF2_15				Reference input 2
	ASCLIN3_ASCLK			O3	Shift clock output
	—	O4	Reserved		
	—	O5	Reserved		
	—	O6	Reserved		
	GPT120_T6OUT	O7	External output for overflow/underflow detection of core timer T6		
	CBS_TGO3	O	Trigger output		
	DAP2	I/O	DAP: DAP2 Data I/O		
	DAPE2	I/O	DAPE: DAPE2 Data I/O		
TDO	O	JTAG Module Data Output			

TC37xEXT Pin Definition and Functions LQFP-144 Package Pinning of

Table 2-64 Port 22 Functions

Pin	Symbol	Ctrl.	Buffer Type	Function	
74	P22.0	I	LVDS_TX / FAST / PU1 / VFLEX2 / ES6	General-purpose input	
	GTM_TIM1_IN1_7			Mux input channel 1 of TIM module 1	
	GTM_TIM0_IN1_7			Mux input channel 1 of TIM module 0	
	QSPI4_MTSRB			Slave SPI data input	
	ASCLIN6_ARXE			Receive input	
	GETH1_CRSDVB			Carrier Sense / Data Valid combi-signal for RMII	
	GETH1_RXDVB			Receive Data Valid MII	
	GETH1_CRSA			Carrier Sense MII	
	P22.0	O0	General-purpose output		
	GTM_TOUT47	O1	GTM muxed output		
	ASCLIN3_ATXN	O2	Differential Transmit output (low active)		
	QSPI4_MTSR	O3	Master SPI data output		
	QSPI4_SCLKN	O4	Master SPI clock output (LVDS N line)		
	MSC1_FCLN	O5	Shift-clock inverted part of the differential signal		
	—	O6	Reserved		
	ASCLIN6_ATX	O7	Transmit output		
75	P22.1	I	LVDS_TX / FAST / PU1 / VFLEX2 / ES6	General-purpose input	
	GTM_TIM1_IN0_8			Mux input channel 0 of TIM module 1	
	GTM_TIM0_IN0_8			Mux input channel 0 of TIM module 0	
	QSPI4_MRSTB			Master SPI data input	
	ASCLIN7_ARXE			Receive input	
	GETH1_RXERA			Receive Error MII	
	P22.1			O0	General-purpose output
	GTM_TOUT48			O1	GTM muxed output
	ASCLIN3_ATXP	O2	Differential Transmit output (high active)		
	QSPI4_MRST	O3	Slave SPI data output		
	IOM_MON2_4		Monitor input 2		
	IOM_REF2_4		Reference input 2		
	QSPI4_SCLKP	O4	Master SPI clock output (LVDS P line)		
	MSC1_FCLP	O5	Shift-clock direct part of the differential signal		
	—	O6	Reserved		
	ASCLIN7_ATX	O7	Transmit output		

TC37xEXT Pin Definition and Functions LQFP-144 Package Pinning of

Table 2-64 Port 22 Functions (cont'd)

Pin	Symbol	Ctrl.	Buffer Type	Function
76	P22.2	I	LVDS_TX / FAST / PU1 / VEXT / ES6	General-purpose input
	GTM_TIM1_IN3_7			Mux input channel 3 of TIM module 1
	GTM_TIM0_IN3_7			Mux input channel 3 of TIM module 0
	QSPI4_SLSIB			Slave select input
	GETH1_COLA			Collision MII
	P22.2	O0	General-purpose output	
	GTM_TOUT49	O1	GTM muxed output	
	ASCLIN5_ATX	O2	Transmit output	
	QSPI4_SLSO3	O3	Master slave select output	
	QSPI4_MTSRN	O4	Master SPI data output (LVDS N line)	
	MSC1_SON	O5	Data output - inverted part of the differential signal	
	—	O6	Reserved	
	—	O7	Reserved	
77	P22.3	I	LVDS_TX / FAST / PU1 / VEXT / ES6	General-purpose input
	GTM_TIM1_IN4_4			Mux input channel 4 of TIM module 1
	GTM_TIM0_IN4_4			Mux input channel 4 of TIM module 0
	QSPI4_SCLKB			Slave SPI clock inputs
	ASCLIN5_ARXC			Receive input
	P22.3	O0	General-purpose output	
	GTM_TOUT50	O1	GTM muxed output	
	—	O2	Reserved	
	QSPI4_SCLK	O3	Master SPI clock output	
	QSPI4_MTSRP	O4	Master SPI data output (LVDS P line)	
	MSC1_SOP	O5	Data output - direct part of the differential signal	
	—	O6	Reserved	
	—	O7	Reserved	

TC37xEXT Pin Definition and Functions LQFP-144 Package Pinning of

Table 2-65 Port 23 Functions

Pin	Symbol	Ctrl.	Buffer Type	Function
73	P23.1	I	FAST / PU1 / VEXT / ES	General-purpose input
	GTM_TIM1_IN6_4			Mux input channel 6 of TIM module 1
	GTM_TIM0_IN6_4			Mux input channel 6 of TIM module 0
	MSC1_SDI0			Upstream asynchronous input signal
	ASCLIN6_ARXF			Receive input
	P23.1	O0	General-purpose output	
	GTM_TOUT42	O1	GTM muxed output	
	ASCLIN1_ARTS	O2	Ready to send output	
	QSPI4_SLSO6	O3	Master slave select output	
	GTM_CLK0	O4	CGM generated clock	
	CAN10_TXD	O5	CAN transmit output node 0	
	CCU_EXTCLK0	O6	External Clock 0	
	ASCLIN6_ASCLK	O7	Shift clock output	

Table 2-66 Port 32 Functions

Pin	Symbol	Ctrl.	Buffer Type	Function
70	P32.0	I	SLOW / PU1 / VEXT / ES	General-purpose input P32.0 / SMPS mode: analog output. External Pass Device gate control for EVRC
	GTM_TIM3_IN2_5			Mux input channel 2 of TIM module 3
	GTM_TIM2_IN2_5			Mux input channel 2 of TIM module 2
	P32.0	O0	General-purpose output	
	GTM_TOUT36	O1	GTM muxed output	
	—	O2	Reserved	
	—	O3	Reserved	
	—	O4	Reserved	
	—	O5	Reserved	
	—	O6	Reserved	
	—	O7	Reserved	

TC37xEXT Pin Definition and Functions LQFP-144 Package Pinning of

Table 2-66 Port 32 Functions (cont'd)

Pin	Symbol	Ctrl.	Buffer Type	Function
71	P32.1	I	SLOW / PU1 / VEXT / ES	General-purpose input P32.1 / External Pass Device gate control for EVRC
	GTM_TIM3_IN3_15			Mux input channel 3 of TIM module 3
	P32.1	O0		General-purpose output
	GTM_TOUT37	O1		GTM muxed output
	—	O2		Reserved
	—	O3		Reserved
	—	O4		Reserved
	—	O5		Reserved
	—	O6		Reserved
	—	O7		Reserved
72	P32.4	I	FAST / PU1 / VEXT / ES	General-purpose input
	GTM_TIM1_IN5_5			Mux input channel 5 of TIM module 1
	GTM_TIM0_IN5_5			Mux input channel 5 of TIM module 0
	ASCLIN1_ACTSB			Clear to send input
	MSC1_SDI2			Upstream asynchronous input signal
	P32.4	O0		General-purpose output
	GTM_TOUT40	O1		GTM muxed output
	—	O2		Reserved
	—	O3		Reserved
	GTM_CLK1	O4		CGM generated clock
	MSC1_EN0	O5		Chip Select
	CCU_EXTCLK1	O6		External Clock 1
	CCU60_COUT63	O7		T13 PWM channel 63
	IOM_MON1_6			Monitor input 1
	IOM_REF1_0			Reference input 1
	PMS_DCDCSYNCO			O

TC37xEXT Pin Definition and Functions LQFP-144 Package Pinning of

Table 2-67 Port 33 Functions

Pin	Symbol	Ctrl.	Buffer Type	Function
60	P33.4	I	SLOW / PU1 / VEVRSB / ES5	General-purpose input
	GTM_TIM4_IN4_10			Mux input channel 4 of TIM module 4
	GTM_TIM1_IN0_10			Mux input channel 0 of TIM module 1
	GTM_TIM0_IN0_10			Mux input channel 0 of TIM module 0
	EDSADC_ITR0F			Trigger/Gate input, channel 0
	SENT_SENT6C			Receive input channel 6
	EDSADC_DSDIN1B			Digital datastream input, channel 1
	CCU61_CTRAPC			Trap input capture
	ASCLIN5_ARXB			Receive input
	IOM_PIN_4			GPIO pad input to FPC
	GTM_DTMT2_0			CDTM2_DTM0
	EVADC_G10CH3			AI
	P33.4	O0	General-purpose output	
	GTM_TOUT26	O1	GTM muxed output	
	IOM_MON0_4		Monitor input 0	
	IOM_GTM_4		GTM-provided inputs to EXOR combiner	
	ASCLIN2_ARTS	O2	Ready to send output	
	QSPI2_SLSO12	O3	Master slave select output	
	PSI5_TX1	O4	TXD outputs (send data)	
	IOM_MON1_15		Monitor input 1	
	EVADC_EMUX12	O5	Control of external analog multiplexer interface 1	
	EVADC_FC0BFLOUT	O6	Boundary flag output, FC channel 0	
	CAN13_TXD	O7	CAN transmit output node 3	

TC37xEXT Pin Definition and Functions LQFP-144 Package Pinning of

Table 2-67 Port 33 Functions (cont'd)

Pin	Symbol	Ctrl.	Buffer Type	Function
61	P33.5	I	SLOW / PU1 / VEVRSB / ES5	General-purpose input
	GTM_TIM4_IN5_10			Mux input channel 5 of TIM module 4
	GTM_TIM1_IN1_8			Mux input channel 1 of TIM module 1
	GTM_TIM0_IN1_8			Mux input channel 1 of TIM module 0
	EDSADC_DSCIN0B			Modulator clock input, channel 0
	EDSADC_ITR1F			Trigger/Gate input, channel 1
	GPT120_T4EUDB			Count direction control input of timer T4
	PSI5S_RXC			RX data input
	ASCLIN2_ACTSB			Clear to send input
	CCU61_CCPOS2C			Hall capture input 2
	SENT_SENT5C			Receive input channel 5
	CAN13_RXDB			CAN receive input node 3
	IOM_PIN_5			GPIO pad input to FPC
	EVADC_G10CH2	AI	Analog input channel 2, group 10	
	P33.5	O0	General-purpose output	
	GTM_TOUT27	O1	GTM muxed output	
	IOM_MON0_5		Monitor input 0	
	IOM_GTM_5		GTM-provided inputs to EXOR combiner	
	QSPI0_SLSO7	O2	Master slave select output	
	QSPI1_SLSO7	O3	Master slave select output	
EDSADC_DSCOUT0	O4	Modulator clock output		
EVADC_EMUX11	O5	Control of external analog multiplexer interface 1		
EVADC_FC2BFLOUT	O6	Boundary flag output, FC channel 2		
ASCLIN5_ASLSO	O7	Slave select signal output		

TC37xEXT Pin Definition and Functions LQFP-144 Package Pinning of

Table 2-67 Port 33 Functions (cont'd)

Pin	Symbol	Ctrl.	Buffer Type	Function
62	P33.6	I	SLOW / PU1 / VEVRSB / ES5	General-purpose input
	GTM_TIM1_IN2_9			Mux input channel 2 of TIM module 1
	GTM_TIM0_IN2_9			Mux input channel 2 of TIM module 0
	EDSADC_ITR2F			Trigger/Gate input, channel 2
	GPT120_T2EUDB			Count direction control input of timer T2
	SENT_SENT4C			Receive input channel 4
	CCU61_CCPOS1C			Hall capture input 1
	EDSADC_DSDIN0B			Digital datastream input, channel 0
	ASCLIN8_ARXD			Receive input
	IOM_PIN_6			GPIO pad input to FPC
	GTM_DTMT2_1			CDTM2_DTM0
	EVADC_G10CH1			AI
	P33.6	O0	General-purpose output	
	GTM_TOUT28	O1	GTM muxed output	
	IOM_MON0_6		Monitor input 0	
	IOM_GTM_6		GTM-provided inputs to EXOR combiner	
	ASCLIN2_ASLSO	O2	Slave select signal output	
	QSPI2_SLSO11	O3	Master slave select output	
	—	O4	Reserved	
	EVADC_EMUX10	O5	Control of external analog multiplexer interface 1	
EVADC_FC1BFLOUT	O6	Boundary flag output, FC channel 1		
PSI5S_TX	O7	TX data output		

TC37xEXT Pin Definition and Functions LQFP-144 Package Pinning of

Table 2-67 Port 33 Functions (cont'd)

Pin	Symbol	Ctrl.	Buffer Type	Function
63	P33.7	I	SLOW / PU1 / VEVRSB / ES5	General-purpose input
	GTM_TIM1_IN3_9			Mux input channel 3 of TIM module 1
	GTM_TIM0_IN3_9			Mux input channel 3 of TIM module 0
	CAN00_RXDE			CAN receive input node 0
	GPT120_T2INB			Trigger/gate input of timer T2
	CCU61_CCPOS0C			Hall capture input 0
	SCU_E_REQ4_0			ERU Channel 4 inputs 0 to 5 (0 is the LSB and 5 is the MSB)
	SENT_SENT14C			Receive input channel 14
	IOM_PIN_7			GPIO pad input to FPC
	EVADC_G10CH0	AI	Analog input channel 0, group 10	
	P33.7	O0	General-purpose output	
	GTM_TOUT29	O1	GTM muxed output	
	IOM_MON0_7	O1	Monitor input 0	
	IOM_GTM_7		GTM-provided inputs to EXOR combiner	
	ASCLIN2_ASCLK	O2	Shift clock output	
	QSPI4_SLSO7	O3	Master slave select output	
	ASCLIN8_ATX	O4	Transmit output	
	—	O5	Reserved	
	EVADC_FC3BFLOUT	O6	Boundary flag output, FC channel 3	
—	O7	Reserved		

TC37xEXT Pin Definition and Functions LQFP-144 Package Pinning of

Table 2-67 Port 33 Functions (cont'd)

Pin	Symbol	Ctrl.	Buffer Type	Function
64	P33.8	I	FAST / HighZ / VEVR SB	General-purpose input
	GTM_TIM1_IN4_7			Mux input channel 4 of TIM module 1
	GTM_TIM0_IN4_7			Mux input channel 4 of TIM module 0
	ASCLIN2_ARXE			Receive input
	SCU_EMGSTOP_PORT_A			Emergency stop Port Pin A input request
	IOM_PIN_8			GPIO pad input to FPC
	P33.8	O0		General-purpose output
	GTM_TOUT30	O1		GTM muxed output
	IOM_MON0_8			Monitor input 0
	ASCLIN2_ATX	O2		Transmit output
	IOM_MON2_14			Monitor input 2
	IOM_REF2_14			Reference input 2
	QSPI4_SLSO2	O3		Master slave select output
	—	O4		Reserved
	CAN00_TXD	O5		CAN transmit output node 0
	IOM_MON2_5			Monitor input 2
	IOM_REF2_5			Reference input 2
	—	O6		Reserved
	CCU61_COUT62	O7		T12 PWM channel 62
	IOM_MON1_13			Monitor input 1
IOM_REF1_8			Reference input 1	
SMU_FSP0	O		FSP[1..0] Output Signals - Generated by SMU_core	

TC37xEXT Pin Definition and Functions LQFP-144 Package Pinning of

Table 2-67 Port 33 Functions (cont'd)

Pin	Symbol	Ctrl.	Buffer Type	Function
65	P33.9	I	SLOW / PU1 / VEVRSB / ES5	General-purpose input
	GTM_TIM1_IN1_9			Mux input channel 1 of TIM module 1
	GTM_TIM0_IN1_9			Mux input channel 1 of TIM module 0
	IOM_PIN_9			GPIO pad input to FPC
	P33.9	O0		General-purpose output
	GTM_TOUT31	O1		GTM muxed output
	IOM_MON0_9			Monitor input 0
	ASCLIN2_ATX	O2		Transmit output
	IOM_MON2_14			Monitor input 2
	IOM_REF2_14			Reference input 2
	QSPI4_SLSO1	O3		Master slave select output
	ASCLIN2_ASCLK	O4		Shift clock output
	CAN01_TXD	O5		CAN transmit output node 1
	IOM_MON2_6			Monitor input 2
	IOM_REF2_6			Reference input 2
	ASCLIN0_ATX	O6		Transmit output
	IOM_MON2_12			Monitor input 2
	IOM_REF2_12			Reference input 2
	CCU61_CC62	O7		T12 PWM channel 62
	IOM_MON1_10			Monitor input 1
IOM_REF1_11			Reference input 1	

TC37xEXT Pin Definition and Functions LQFP-144 Package Pinning of

Table 2-67 Port 33 Functions (cont'd)

Pin	Symbol	Ctrl.	Buffer Type	Function
66	P33.10	I	FAST / PU1 / VEVR SB / ES5	General-purpose input
	GTM_TIM4_IN4_14			Mux input channel 4 of TIM module 4
	GTM_TIM1_IN0_9			Mux input channel 0 of TIM module 1
	GTM_TIM0_IN0_9			Mux input channel 0 of TIM module 0
	QSPI4_SLSIA			Slave select input
	CAN01_RXDD			CAN receive input node 1
	ASCLIN0_ARXD			Receive input
	IOM_PIN_10			GPIO pad input to FPC
	P33.10			O0
	GTM_TOUT32	O1	GTM muxed output	
	IOM_MON0_10	O2	Monitor input 0	
	QSPI1_SLSO6		Master slave select output	
	QSPI4_SLSO0		Master slave select output	
	ASCLIN1_ASLSO	O4	Slave select signal output	
	PSI5S_CLK	O5	PSI5S CLK is a clock that can be used on a pin to drive the external PHY.	
	—	O6	Reserved	
	CCU61_COUT61	O7	T12 PWM channel 61	
	IOM_MON1_12		Monitor input 1	
	IOM_REF1_9		Reference input 1	
SMU_FSP1	O	FSP[1..0] Output Signals - Generated by SMU_core		
67	P33.11	I	FAST / PU1 / VEVR SB / ES5	General-purpose input
	GTM_TIM1_IN2_8			Mux input channel 2 of TIM module 1
	GTM_TIM0_IN2_8			Mux input channel 2 of TIM module 0
	QSPI4_SCLKA			Slave SPI clock inputs
	IOM_PIN_11			GPIO pad input to FPC
	P33.11	O0	General-purpose output	
	GTM_TOUT33	O1	GTM muxed output	
	IOM_MON0_11	O2	Monitor input 0	
	ASCLIN1_ASCLK		Shift clock output	
	QSPI4_SCLK		Master SPI clock output	
	—	O4	Reserved	
	—	O5	Reserved	
	EDSADC_CGPWMN	O6	Negative carrier generator output	
	CCU61_CC61	O7	T12 PWM channel 61	
	IOM_MON1_9		Monitor input 1	
IOM_REF1_12	Reference input 1			

TC37xEXT Pin Definition and Functions LQFP-144 Package Pinning of

Table 2-67 Port 33 Functions (cont'd)

Pin	Symbol	Ctrl.	Buffer Type	Function
68	P33.12	I	FAST / PU1 / VEVRSB / ES5	General-purpose input
	GTM_TIM3_IN0_6			Mux input channel 0 of TIM module 3
	GTM_TIM2_IN0_6			Mux input channel 0 of TIM module 2
	QSPI4_MTSRA			Slave SPI data input
	CAN00_RXDD			CAN receive input node 0
	PMS_PINBWKP			PINB (P33.12) pin input
	IOM_PIN_12			GPIO pad input to FPC
	P33.12	O0		General-purpose output
	GTM_TOUT34	O1		GTM muxed output
	IOM_MON0_12			Monitor input 0
	ASCLIN1_ATX	O2		Transmit output
	IOM_MON2_13			Monitor input 2
	IOM_REF2_13			Reference input 2
	QSPI4_MTSR	O3		Master SPI data output
	ASCLIN1_ASCLK	O4		Shift clock output
	CAN22_TXD	O5		CAN transmit output node 2
	EDSADC_CGPWMP	O6		Positive carrier generator output
	CCU61_COUT60	O7		T12 PWM channel 60
	IOM_MON1_11			Monitor input 1
	IOM_REF1_10			Reference input 1

TC37xEXT Pin Definition and Functions LQFP-144 Package Pinning of

Table 2-67 Port 33 Functions (cont'd)

Pin	Symbol	Ctrl.	Buffer Type	Function
69	P33.13	I	FAST / PU1 / VEVR SB / ES5	General-purpose input
	GTM_TIM3_IN1_5			Mux input channel 1 of TIM module 3
	GTM_TIM2_IN1_5			Mux input channel 1 of TIM module 2
	ASCLIN1_ARXF			Receive input
	EDSADC_SGNB			Carrier sign signal input
	QSPI4_MRSTA			Master SPI data input
	MSC1_INJ1			Injection signal from port
	CAN22_RXDA			CAN receive input node 2
	P33.13			O0
	GTM_TOUT35	O1	GTM muxed output	
	ASCLIN1_ATX	O2	Transmit output	
	IOM_MON2_13	O3	Monitor input 2	
	IOM_REF2_13		Reference input 2	
	QSPI4_MRST		Slave SPI data output	
	IOM_MON2_4	O4	Monitor input 2	
	IOM_REF2_4		Reference input 2	
	QSPI2_SLSO6	O4	Master slave select output	
	CAN00_TXD	O5	CAN transmit output node 0	
	IOM_MON2_5	O6	Monitor input 2	
	IOM_REF2_5		Reference input 2	
—	O6	Reserved		
CCU61_CC60	O7	T12 PWM channel 60		
IOM_MON1_8	O7	Monitor input 1		
IOM_REF1_13		Reference input 1		

Table 2-68 Analog Inputs

Pin	Symbol	Ctrl.	Buffer Type	Function
57	AN0	I	D / HighZ / VDDM	Analog Input 0
	EVADC_G0CH0			Analog input channel 0, group 0
	EDSADC_EDS3PA			Positive analog input channel 3, pin A
56	AN1	I	D / HighZ / VDDM	Analog Input 1
	EVADC_G0CH1			Analog input channel 1, group 0
	EDSADC_EDS3NA			Negative analog input channel 3, pin A
55	AN2	I	D / HighZ / VDDM	Analog Input 2
	EVADC_G0CH2			Analog input channel 2, group 0
	EDSADC_EDS0PA			Positive analog input channel 0, pin A

TC37xEXT Pin Definition and Functions LQFP-144 Package Pinning of

Table 2-68 Analog Inputs (cont'd)

Pin	Symbol	Ctrl.	Buffer Type	Function
54	AN3	I	D / HighZ / VDDM	Analog Input 3
	EVADC_G0CH3			Analog input channel 3, group 0
	EDSADC_EDS0NA			Negative analog input channel 0, pin A
53	AN4	I	D / HighZ / VDDM	Analog Input 4
	EVADC_G11CH0			Analog input channel 0, group 11
	EVADC_G0CH4			Analog input channel 4, group 0
52	AN5	I	D / HighZ / VDDM	Analog Input 5
	EVADC_G11CH1			Analog input channel 1, group 11
	EVADC_G0CH5			Analog input channel 5, group 0
51	AN6	I	D / HighZ / VDDM	Analog Input 6
	EVADC_G11CH2			Analog input channel 2, group 11
	EVADC_G0CH6			Analog input channel 6, group 0
50	AN7	I	D / HighZ / VDDM	Analog Input 7
	EVADC_G11CH3			Analog input channel 3, group 11
	EVADC_G0CH7			Analog input channel 7, group 0
49	AN8	I	D / HighZ / VDDM	Analog Input 8
	EVADC_G11CH4			Analog input channel 4, group 11
	EVADC_G1CH0			Analog input channel 0, group 1
48	AN10	I	D / HighZ / VDDM	Analog Input 10
	EVADC_G11CH6			Analog input channel 6, group 11
	EVADC_G1CH2			Analog input channel 2, group 1
47	AN11	I	D / HighZ / VDDM	Analog Input 11
	EVADC_G11CH7			Analog input channel 7, group 11
	EVADC_G1CH3			Analog input channel 3, group 1
46	AN12	I	D / HighZ / VDDM	Analog Input 12
	EVADC_G1CH4			Analog input channel 4, group 1
	EDSADC_EDS0PB			Positive analog input channel 0, pin B
45	AN13	I	D / HighZ / VDDM	Analog Input 13
	EVADC_G1CH5			Analog input channel 5, group 1
	EDSADC_EDS0NB			Negative analog input channel 0, pin B
40	AN16	I	D / HighZ / VDDM	Analog Input 16
	EVADC_G2CH0			Analog input channel 0, group 2
	EVADC_FC0CH0			Analog input FC channel 0
39	AN17/P40.10	I	S / HighZ / VDDM	Analog Input 17
	SENT_SENT10A			Receive input channel 10
	EVADC_G2CH1			Analog input channel 1, group 2
	EVADC_FC1CH0			Analog input FC channel 1

TC37xEXT Pin Definition and Functions LQFP-144 Package Pinning of

Table 2-68 Analog Inputs (cont'd)

Pin	Symbol	Ctrl.	Buffer Type	Function
38	AN20	I	D / HighZ / VDDM	Analog Input 20
	EVADC_G2CH4			Analog input channel 4, group 2
	EDSADC_EDS2PA			Positive analog input channel 2, pin A
37	AN21	I	D / HighZ / VDDM	Analog Input 21
	EVADC_G2CH5			Analog input channel 5, group 2
	EDSADC_EDS2NA			Negative analog input channel 2, pin A
36	AN24/P40.0	I	S / HighZ / VDDM	Analog Input 24
	SENT_SENT0A			Receive input channel 0
	EVADC_G3CH0			Analog input channel 0, group 3
	CCU60_CCPOS0D			Hall capture input 0
	EDSADC_EDS2PB			Positive analog input channel 2, pin B
35	AN25/P40.1	I	S / HighZ / VDDM	Analog Input 25
	SENT_SENT1A			Receive input channel 1
	EVADC_G3CH1			Analog input channel 1, group 3
	CCU60_CCPOS1B			Hall capture input 1
	EDSADC_EDS2NB			Negative analog input channel 2, pin B
34	AN35	I	D / HighZ / VDDM	Analog Input 35
	EVADC_G8CH3			Analog input channel 3, group 8
	EVADC_G11CH15			Analog input channel 15, group 11
33	AN36/P40.6	I	S / HighZ / VDDM	Analog Input 36
	SENT_SENT6A			Receive input channel 6
	EVADC_G8CH4			Analog input channel 4, group 8
	CCU61_CCPOS1B			Hall capture input 1
	EDSADC_EDS1PA			Positive analog input channel 1, pin A
32	AN37/P40.7	I	S / HighZ / VDDM	Analog Input 37
	SENT_SENT7A			Receive input channel 7
	EVADC_G8CH5			Analog input channel 5, group 8
	CCU61_CCPOS1D			Hall capture input 1
	EDSADC_EDS1NA			Negative analog input channel 1, pin A
31	AN38/P40.8	I	S / HighZ / VDDM	Analog Input 38
	SENT_SENT8A			Receive input channel 8
	EVADC_G8CH6			Analog input channel 6, group 8
	CCU61_CCPOS2B			Hall capture input 2
	EDSADC_EDS1PB			Positive analog input channel 1, pin B

TC37xEXT Pin Definition and Functions LQFP-144 Package Pinning of

Table 2-68 Analog Inputs (cont'd)

Pin	Symbol	Ctrl.	Buffer Type	Function
30	AN39/P40.9	I	S / HighZ / VDDM	Analog Input 39
	SENT_SENT9A			Receive input channel 9
	EVADC_G8CH7			Analog input channel 7, group 8
	CCU61_CCPOS2D			Hall capture input 2
	EDSADC_EDS1NB			Negative analog input channel 1, pin B
29	AN44	I	D / HighZ / VDDM	Analog Input 44
	EVADC_G8CH12			Analog input channel 12, group 8
	EDSADC_EDS1PC			Positive analog input channel 1, pin C
28	AN45	I	D / HighZ / VDDM	Analog Input 45
	EVADC_G8CH13			Analog input channel 13, group 8
	EDSADC_EDS1NC			Negative analog input channel 1, pin C
27	AN46	I	D / HighZ / VDDM	Analog Input 46
	EVADC_G8CH14			Analog input channel 14, group 8
	EDSADC_EDS1PD			Positive analog input channel 1, pin D
26	AN47	I	D / HighZ / VDDM	Analog Input 47
	EVADC_G8CH15			Analog input channel 15, group 8
	EDSADC_EDS1ND			Negative analog input channel 1, pin D

Table 2-69 System I/O

Pin	Symbol	Ctrl.	Buffer Type	Function
70	VGATE1N	O	—	DCDC N ch. MOSFET gate driver output P32.0 / SMPS mode: analog output. External Pass Device gate control for EVRC
71	VGATE1P	O	—	DCDC P ch. MOSFET gate driver output P32.1 / External Pass Device gate control for EVRC
81	XTAL1	I	XTAL / VEXT	XTAL pad1 XTAL1. Main Oscillator/PLL/Clock Generator Input.
82	XTAL2	O	XTAL / VEXT	XTAL pad2 XTAL2. Main Oscillator/PLL/Clock Generator OUTPUT
89	TMS	I	FAST / PD2 / VEXT	JTAG Module State Machine Control Input TMS: JTAG Module State Machine Control Input. DAP: DAP1 Data I/O.
	DAP1	I/O		DAP: DAP1 Data I/O
91	$\overline{\text{TRST}}$	I	FAST / PU2 / VEXT	JTAG Module Reset/Enable Input TRST_N: JTAG Module Reset/Enable Input. DAPE: DAPE0 Clock Input
	DAPE0	I		DAPE: DAPE0 Clock Input

TC37xEXT Pin Definition and Functions LQFP-144 Package Pinning of

Table 2-69 System I/O (cont'd)

Pin	Symbol	Ctrl.	Buffer Type	Function
92	TCK	I	FAST / PD2 /	JTAG Module Clock Input TCK: JTAG Module Clock Input. DAP: DAP0 Clock Input.
	DAP0	I	VEXT	DAP: DAP0 Clock Input
96	$\overline{\text{ESR1}}$	I	FAST / PU1 / VEXT	ESR1 Port Pin input - can be used to trigger a reset or an NMI ESR1: External System Request Reset 1. Default NMI function. See also SCU chapter for details. Default after power-on can be different. See also SCU chapter 'Reset Control Unit' and SCU_IOCRR register description. PMS_EVRWUP: EVR Wakeup Pin
	PMS_ESR1WKP	I		ESR1 pin input
97	$\overline{\text{PORST}}$	I/O	PORST / PD / VEXT	PORST pin Power On Reset Input. Additional strong PD in case of power fail.
98	$\overline{\text{ESR0}}$	I	FAST / OD / VEXT	ESR0 Port Pin input - can be used to trigger a reset or an NMI ESR0: External System Request Reset 0. Default configuration during and after reset is open-drain driver. The driver drives low during power-on reset. This is valid additionally after deactivation of PORST_N until the internal reset phase has finished. See also SCU chapter for details. Default after power-on can be different. See also SCU chapter 'Reset Control Unit' and SCU_IOCRR register description. PMS_EVRWUP: EVR Wakeup Pin
	PMS_ESR0WKP	I		ESR0 pin input

Table 2-70 Supply

Pin	Symbol	Ctrl.	Buffer Type	Function
136	VFLEX	I	—	Digital Power Supply for Flex Port Pads (5V / 3.3V)
44	VDDM	I	—	ADC Analog Power Supply (5V / 3.3V)
126	VDDP3	I	—	Flash Power Supply (3.3V)
42	VAREF1	I	—	Positive Analog Reference Voltage 1
24	VAREF2	I	—	Positive Analog Reference Voltage 2
10	VDDSB (VDD)	I	—	Devices with integrated EMEM: EMEM SRAM Standby Power Supply, VDDSB (1.25V); Devices without integrated EMEM: VDD (1.25V)
59	VEVRSB	I	—	Standby Power Supply (5V / 3.3V) for the Standby SRAM
125	VEXT	I	—	External Power Supply (5V / 3.3V)
23	VEXT	I	—	External Power Supply (5V / 3.3V)
78	VEXT	I	—	External Power Supply (5V / 3.3V)

TC37xEXT Pin Definition and Functions LQFP-144 Package Pinning of

Table 2-70 Supply (cont'd)

Pin	Symbol	Ctrl.	Buffer Type	Function
127	VDD	I	—	Digital Core Power Supply (1.25V)
22	VDD	I	—	Digital Core Power Supply (1.25V)
58	VDD	I	—	Digital Core Power Supply (1.25V)
79	VDD	I	—	Digital Core Power Supply (1.25V)
99	VDD	I	—	Digital Core Power Supply (1.25V)
145	VSS	I	—	Digital Ground (Exposed PAD), VSS
43	VSSM	I	—	Analog Ground for VDDM
41	VAGND1	I	—	Negative Analog Reference Voltage 1
25	VAGND2	I	—	Negative Analog Reference Voltage 2
80	VSS	I	—	Oscillator Ground, VSS(OSC)
83	VEXT	I	—	Digital Power Supply for Oscillator (shall be supplied with same level as used for VEXT), VEXT(OSC)

TC37xEXT Pin Definition and Functions Pad Position Configuration of
2.5 Pad Position Configuration of TC37xEXT
Table 2-71 Pad List

Number	Pad Name	Pad Type	X	Y	Comment
1	VEXT	Vx	255699	175644	Supply Voltage
2	VSS	Vx	356499	185148	Supply Voltage
3	VSS	Vx	457299	185148	Supply Voltage
4	VDD	Vx	507699	344106	Supply Voltage
5	P15.0	FAST / PU1 / VEXT / ES	558099	185148	General-purpose I/O
6	P15.1	FAST / PU1 / VEXT / ES	608499	344106	General-purpose I/O
7	P15.2	FAST / PU1 / VEXT / ES	658899	185148	General-purpose I/O
8	P15.3	FAST / PU1 / VEXT / ES	709299	344106	General-purpose I/O
9	P15.4	FAST / PU1 / VEXT / ES	756297	185148	General-purpose I/O
10	P15.5	FAST / PU1 / VEXT / ES	803295	344106	General-purpose I/O
11	P15.6	FAST / PU1 / VEXT / ES	850293	185148	General-purpose I/O
12	P15.7	FAST / PU1 / VEXT / ES	897291	344106	General-purpose I/O
13	P15.8	FAST / PU1 / VEXT / ES	944289	185148	General-purpose I/O
14	P14.0	FAST / PU1 / VEXT / ES2	991287	344106	General-purpose I/O
15	VDD	Vx	1076499	185148	Supply Voltage
16	P14.1	FAST / PU1 / VEXT / ES2	1161999	344106	General-purpose I/O
17	VSS	Vx	1238499	185148	Supply Voltage
18	P14.2	SLOW / PU2 / VEXT / ES	1319499	344106	General-purpose I/O
19	VSS	Vx	1366497	185148	Supply Voltage
20	P14.3	SLOW / PU2 / VEXT / ES	1413495	344106	General-purpose I/O
21	VEXT	Vx	1460493	175644	Supply Voltage
22	P14.4	SLOW / PU2 / VEXT / ES	1507491	344106	General-purpose I/O
23	P14.5	FAST / PU2 / VEXT / ES	1554489	185148	General-purpose I/O
24	P14.6	FAST / PU1 / VEXT / ES	1601487	344106	General-purpose I/O

TC37xEXT Pin Definition and Functions Pad Position Configuration of
Table 2-71 Pad List (cont'd)

Number	Pad Name	Pad Type	X	Y	Comment
25	P14.7	SLOW / PU1 / VEXT / ES	1648485	185148	General-purpose I/O
26	P14.8	SLOW / PU1 / VEXT / ES	1695483	344106	General-purpose I/O
27	P14.9	LVDS_RX / FAST / PU1 / VEXT / ES	1770534	185148	General-purpose I/O
28	P14.10	LVDS_RX / FAST / PU1 / VEXT / ES	1864530	185148	General-purpose I/O
29	VDD	Vx	1939581	344106	Supply Voltage
30	VSS	Vx	1986579	185148	Supply Voltage
31	VEXT	Vx	2033577	344106	Supply Voltage
32	VEXT	Vx	2093499	185148	Supply Voltage
33	VEXT	Vx	2164599	344106	Supply Voltage
34	VDDP3	Vx	2346597	185148	Supply Voltage
35	VDDP3	Vx	2453499	344106	Supply Voltage
36	VDDP3	Vx	2543499	185148	Supply Voltage
37	VDD	Vx	2669499	344106	Supply Voltage
38	VDD	Vx	2768499	185148	Supply Voltage
39	VDD	Vx	2826477	344106	Supply Voltage
40	VSS	Vx	2873475	185148	Supply Voltage
41	P13.0	LVDS_TX / FAST / PU1 / VEXT / ES6	2984976	344106	General-purpose I/O
42	P13.1	LVDS_TX / FAST / PU1 / VEXT / ES6	3078972	344106	General-purpose I/O
43	VSS	Vx	3190473	185148	Supply Voltage
44	P13.2	LVDS_TX / FAST / PU1 / VEXT / ES6	3301974	344106	General-purpose I/O
45	P13.3	LVDS_TX / FAST / PU1 / VEXT / ES6	3395970	344106	General-purpose I/O
46	VDDP3	Vx	3507471	338112	Supply Voltage
47	VSS	Vx	3554469	185148	Supply Voltage
48	VDD	Vx	3645999	322614	Supply Voltage
49	VEXT	Vx	3692997	175644	Supply Voltage
50	P12.0	SLOW / PU1 / VFLEX / ES	3767211	322614	General-purpose I/O

TC37xEXT Pin Definition and Functions Pad Position Configuration of
Table 2-71 Pad List (cont'd)

Number	Pad Name	Pad Type	X	Y	Comment
51	P12.1	SLOW / PU1 / VFLEX / ES	3814209	175644	General-purpose I/O
52	P11.0	RFAST / PU1 / VFLEX / ES	3918213	322614	General-purpose I/O
53	VFLEX	Vx	3965211	175644	Supply Voltage
54	P11.1	RFAST / PU1 / VFLEX / ES	4040415	338112	General-purpose I/O
55	VSS	Vx	4087413	185148	Supply Voltage
56	P11.2	RFAST / PU1 / VFLEX / ES	4162617	344106	General-purpose I/O
57	VDD	Vx	4209615	175644	Supply Voltage
58	P11.4	RFAST / PU1 / VFLEX / ES	4325319	322614	General-purpose I/O
59	VSS	Vx	4412817	185148	Supply Voltage
60	P11.3	RFAST / PU1 / VFLEX / ES	4488021	344106	General-purpose I/O
61	VFLEX	Vx	4535019	175644	Supply Voltage
62	P11.6	RFAST / PU1 / VFLEX / ES	4610223	344106	General-purpose I/O
63	VSS	Vx	4657221	185148	Supply Voltage
64	P11.5	SLOW / RGMII_Input / PU1 / VFLEX / ES	4704219	338112	General-purpose I/O
65	P11.7	SLOW / RGMII_Input / PU1 / VFLEX / ES	4756617	175644	General-purpose I/O
66	P11.9	FAST / RGMII_Input / PU1 / VFLEX / ES	4807215	344106	General-purpose I/O
67	VFLEX	Vx	4857813	185148	Supply Voltage
68	P11.8	SLOW / RGMII_Input / PU1 / VFLEX / ES	4904811	338112	General-purpose I/O
69	P11.10	FAST / RGMII_Input / PU1 / VFLEX / ES	4955409	185148	General-purpose I/O

TC37xEXT Pin Definition and Functions Pad Position Configuration of
Table 2-71 Pad List (cont'd)

Number	Pad Name	Pad Type	X	Y	Comment
70	P11.11	FAST / RGMII_Input / PU1 / VFLEX / ES	5006007	344106	General-purpose I/O
71	VSS	Vx	5056605	185148	Supply Voltage
72	P11.12	FAST / RGMII_Input / PU1 / VFLEX / ES	5103603	344106	General-purpose I/O
73	VSS	Vx	5211999	185148	Supply Voltage
74	VDD	Vx	5312493	322614	Supply Voltage
75	P11.14	SLOW / PU1 / VFLEX / ES	5397291	175644	General-purpose I/O
76	P11.13	SLOW / PU1 / VFLEX / ES	5444289	322614	General-purpose I/O
77	P11.15	SLOW / PU1 / VFLEX / ES	5491287	175644	General-purpose I/O
78	P10.0	SLOW / PU1 / VEXT / ES	5565501	344106	General-purpose I/O
79	P10.1	FAST / PU1 / VEXT / ES	5612499	185148	General-purpose I/O
80	VDD	Vx	5702499	322614	Supply Voltage
81	VSS	Vx	5792499	185148	Supply Voltage
82	VDDSB (VDD)	Vx	5839497	338112	Supply Voltage
83	VDDSB (VDD)	Vx	5940999	338112	Supply Voltage
84	VSS	Vx	5987997	185148	Supply Voltage
85	P10.2	FAST / PU1 / VEXT / ES	6068601	344106	General-purpose I/O
86	P10.3	FAST / PU1 / VEXT / ES	6115599	185148	General-purpose I/O
87	P10.4	FAST / PU1 / VEXT / ES	6165999	344106	General-purpose I/O
88	P10.5	SLOW / PU2 / VEXT / ES	6216399	185148	General-purpose I/O
89	P10.6	SLOW / PU2 / VEXT / ES	6266799	344106	General-purpose I/O
90	P10.7	SLOW / PU1 / VEXT / ES	6317199	185148	General-purpose I/O
91	P10.8	SLOW / PU1 / VEXT / ES	6367599	344106	General-purpose I/O
92	VSS	Vx	6436899	185148	Supply Voltage
93	VEXT	Vx	6537699	175644	Supply Voltage

TC37xEXT Pin Definition and Functions Pad Position Configuration of
Table 2-71 Pad List (cont'd)

Number	Pad Name	Pad Type	X	Y	Comment
94	P02.0	FAST / PU1 / VEXT / ES	6611292	259700	General-purpose I/O
95	P02.1	SLOW / PU1 / VEXT / ES	6611292	360500	General-purpose I/O
96	P02.2	FAST / PU1 / VEXT / ES	6611292	461300	General-purpose I/O
97	P02.3	SLOW / PU1 / VEXT / ES	6611292	562100	General-purpose I/O
98	P02.4	FAST / PU1 / VEXT / ES	6611292	662900	General-purpose I/O
99	VSS	Vx	6611292	772898	Supply Voltage
100	VDDSB (VDD)	Vx	6452334	827896	Supply Voltage
101	VDDSB (VDD)	Vx	6452334	972500	Supply Voltage
102	VSS	Vx	6611292	1027498	Supply Voltage
103	P02.5	FAST / PU1 / VEXT / ES	6452334	1107500	General-purpose I/O
104	P02.6	FAST / PU1 / VEXT / ES	6611292	1170500	General-purpose I/O
105	P02.7	FAST / PU1 / VEXT / ES	6452334	1233500	General-purpose I/O
106	P02.8	SLOW / PU1 / VEXT / ES	6611292	1296500	General-purpose I/O
107	VDD	Vx	6458328	1377500	Supply Voltage
108	VDD	Vx	6620796	1467500	Supply Voltage
109	VSS	Vx	6611292	1602500	Supply Voltage
110	VSS	Vx	6611292	1746500	Supply Voltage
111	VDDSB (VDD)	Vx	6452334	1801498	Supply Voltage
112	VDDSB (VDD)	Vx	6452334	1962500	Supply Voltage
113	VSS	Vx	6611292	2017498	Supply Voltage
114	P02.9	SLOW / PU1 / VEXT / ES	6473826	2124500	General-purpose I/O
115	P02.10	SLOW / PU1 / VEXT / ES	6620796	2187500	General-purpose I/O
116	P02.11	SLOW / PU1 / VEXT / ES	6458328	2250500	General-purpose I/O
117	VEXT	Vx	6620796	2313500	Supply Voltage
118	P01.3	SLOW / PU1 / VEXT / ES	6458328	2376500	General-purpose I/O
119	VSS	Vx	6611292	2431498	Supply Voltage
120	VSS	Vx	6611292	2529500	Supply Voltage
121	VDDSB (VDD)	Vx	6458328	2584498	Supply Voltage

TC37xEXT Pin Definition and Functions Pad Position Configuration of
Table 2-71 Pad List (cont'd)

Number	Pad Name	Pad Type	X	Y	Comment
122	VDDSB (VDD)	Vx	6458328	2718500	Supply Voltage
123	VSS	Vx	6611292	2773498	Supply Voltage
124	VDD	Vx	6458328	2907500	Supply Voltage
125	VSS	Vx	6611292	2970500	Supply Voltage
126	VDD	Vx	6458328	3033500	Supply Voltage
127	VEXT	Vx	6620796	3096500	Supply Voltage
128	P01.4	SLOW / PU1 / VEXT / ES	6473826	3159500	General-purpose I/O
129	P01.5	SLOW / PU1 / VEXT / ES	6620796	3222500	General-purpose I/O
130	P01.6	FAST / PU1 / VEXT / ES	6473826	3285500	General-purpose I/O
131	P01.7	FAST / PU1 / VEXT / ES	6473826	3411500	General-purpose I/O
132	VSS	Vx	6611292	3537500	Supply Voltage
133	VSS	—	6611292	3672500	Supply Voltage
134	P00.0	FAST / PU1 / VEXT / ES	6452334	3807500	General-purpose I/O
135	VDD	Vx	6620796	3942500	Supply Voltage
136	VDD	—	6620796	4055000	Supply Voltage
137	P00.1	SLOW / PU1 / VEXT / ES	6611292	4209430	General-purpose I/O
138	P00.2	SLOW / PU1 / VEXT / ES1	6433794	4264430	General-purpose I/O
139	P00.3	SLOW / PU1 / VEXT / ES1	6611292	4319428	General-purpose I/O
140	P00.4	SLOW / PU1 / VEXT / ES1	6433794	4374428	General-purpose I/O
141	P00.5	SLOW / PU1 / VEXT / ES1	6611292	4429426	General-purpose I/O
142	P00.6	SLOW / PU1 / VEXT / ES1	6433794	4484426	General-purpose I/O
143	P00.7	SLOW / PU1 / VEXT / ES1	6611292	4539424	General-purpose I/O
144	P00.8	SLOW / PU1 / VEXT / ES1	6433794	4594424	General-purpose I/O
145	P00.9	SLOW / PU1 / VEXT / ES1	6611292	4649422	General-purpose I/O
146	P00.10	SLOW / PU1 / VEXT / ES1	6433794	4704422	General-purpose I/O
147	P00.11	SLOW / PU1 / VEXT / ES1	6611292	4759420	General-purpose I/O

TC37xEXT Pin Definition and Functions Pad Position Configuration of
Table 2-71 Pad List (cont'd)

Number	Pad Name	Pad Type	X	Y	Comment
148	P00.12	SLOW / PU1 / VEXT / ES1	6433794	4814420	General-purpose I/O
149	VSS	Vx	6611292	4869418	Supply Voltage
150	VSS	Vx	6611292	4968518	Supply Voltage
151	VDD	Vx	6611292	5067616	Supply Voltage
152	VDD	Vx	6611292	5166716	Supply Voltage
153	VEXT	Vx	6611292	5265814	Supply Voltage
154	VAREF3	Vx	6611292	5404730	Supply Voltage
155	VAGND3	Vx	6611292	5503828	Supply Voltage
156	VAREF2	Vx	6433794	5558828	Supply Voltage
157	VAGND2	Vx	6611292	5613826	Supply Voltage
158	AN47	D / HighZ / VDDM	6611292	5712926	Analog Input 47
159	AN46	D / HighZ / VDDM	6433794	5767924	Analog Input 46
160	AN45	D / HighZ / VDDM	6611292	5822924	Analog Input 45
161	AN44	D / HighZ / VDDM	6433794	5877922	Analog Input 44
162	AN43	D / HighZ / VDDM	6611292	5932922	Analog Input 43
163	AN42	D / HighZ / VDDM	6433794	5987920	Analog Input 42
164	AN41	D / HighZ / VDDM	6611292	6042920	Analog Input 41
165	AN40	D / HighZ / VDDM	6433794	6097918	Analog Input 40
166	AN39/P40.9	S / HighZ / VDDM	6611292	6262916	Analog Input 39
167	AN38/P40.8	S / HighZ / VDDM	6433794	6317914	Analog Input 38
168	AN37/P40.7	S / HighZ / VDDM	6611292	6372914	Analog Input 37
169	AN36/P40.6	S / HighZ / VDDM	6433794	6427912	Analog Input 36
170	AN35	D / HighZ / VDDM	6611292	6482912	Analog Input 35
171	AN34	D / HighZ / VDDM	6433794	6537910	Analog Input 34
172	AN33/P40.5	S / HighZ / VDDM	6611292	6592910	Analog Input 33

TC37xEXT Pin Definition and Functions Pad Position Configuration of
Table 2-71 Pad List (cont'd)

Number	Pad Name	Pad Type	X	Y	Comment
173	AN32/P40.4	S / HighZ / VDDM	6433794	6647908	Analog Input 32
174	AN31	D / HighZ / VDDM	6611292	6702908	Analog Input 31
175	AN30	D / HighZ / VDDM	6433794	6757906	Analog Input 30
176	AN29/P40.14	S / HighZ / VDDM	6611292	6812906	Analog Input 29
177	AN28/P40.13	S / HighZ / VDDM	6433794	6867904	Analog Input 28
178	AN27/P40.3	S / HighZ / VDDM	6611292	6922904	Analog Input 27
179	AN26/P40.2	S / HighZ / VDDM	6433794	6977902	Analog Input 26
180	AN25/P40.1	S / HighZ / VDDM	6611292	7032902	Analog Input 25
181	AN24/P40.0	S / HighZ / VDDM	6611292	7156300	Analog Input 24
182	AN23	D / HighZ / VDDM	6526440	7241292	Analog Input 23
183	AN22	D / HighZ / VDDM	6403140	7241292	Analog Input 22
184	AN21	D / HighZ / VDDM	6348141	7063794	Analog Input 21
185	AN20	D / HighZ / VDDM	6293142	7241292	Analog Input 20
186	AN19/P40.12	S / HighZ / VDDM	6238143	7063794	Analog Input 19
187	AN18/P40.11	S / HighZ / VDDM	6183144	7241292	Analog Input 18
188	AN17/P40.10	S / HighZ / VDDM	6128145	7063794	Analog Input 17
189	AN16	D / HighZ / VDDM	6073146	7241292	Analog Input 16
190	AN15	D / HighZ / VDDM	6018147	7063794	Analog Input 15
191	VAGND1	Vx	5963148	7241292	Supply Voltage
192	VAREF1	Vx	5908149	7063794	Supply Voltage
193	VAGND0	Vx	5853150	7241292	Supply Voltage
194	VAREF0	Vx	5798151	7063794	Supply Voltage
195	VSSM	Vx	5743152	7241292	Supply Voltage
196	VDDM	Vx	5688153	7063794	Supply Voltage

TC37xEXT Pin Definition and Functions Pad Position Configuration of
Table 2-71 Pad List (cont'd)

Number	Pad Name	Pad Type	X	Y	Comment
197	VSSM	Vx	5633154	7241292	Supply Voltage
198	VDDM	Vx	5578155	7063794	Supply Voltage
199	VSSM	Vx	5523156	7241292	Supply Voltage
200	VDDM	Vx	5468157	7063794	Supply Voltage
201	AN14	D / HighZ / VDDM	5413158	7241292	Analog Input 14
202	AN13	D / HighZ / VDDM	5358159	7063794	Analog Input 13
203	AN12	D / HighZ / VDDM	5303160	7241292	Analog Input 12
204	AN11	D / HighZ / VDDM	5248161	7063794	Analog Input 11
205	AN10	D / HighZ / VDDM	5193162	7241292	Analog Input 10
206	AN9	D / HighZ / VDDM	5138163	7063794	Analog Input 9
207	AN8	D / HighZ / VDDM	5083164	7241292	Analog Input 8
208	AN7	D / HighZ / VDDM	5028165	7063794	Analog Input 7
209	AN6	D / HighZ / VDDM	4973166	7241292	Analog Input 6
210	AN5	D / HighZ / VDDM	4918167	7063794	Analog Input 5
211	AN4	D / HighZ / VDDM	4863168	7241292	Analog Input 4
212	AN3	D / HighZ / VDDM	4808169	7063794	Analog Input 3
213	AN2	D / HighZ / VDDM	4753170	7241292	Analog Input 2
214	AN1	D / HighZ / VDDM	4698171	7063794	Analog Input 1
215	AN0	D / HighZ / VDDM	4643172	7241292	Analog Input 0
216	VDD	Vx	4525070	7241292	Supply Voltage
217	VDD	Vx	4467501	7082334	Supply Voltage
218	VSS	Vx	4386501	7241292	Supply Voltage
219	AGBTCLKN (VSS)	AGBT_CLK / VEXT	4230531	7250841	Input PAD (negative pole) for the external 100 MHz differential clock. AGBT Input; (TC3xx devices without AGBT: VSS)

TC37xEXT Pin Definition and Functions Pad Position Configuration of
Table 2-71 Pad List (cont'd)

Number	Pad Name	Pad Type	X	Y	Comment
220	AGBTCLKP (VSS)	AGBT_CLK / VEXT	4149441	7250841	Input PAD (positive pole) for the external 100 MHz differential clock. AGBT Input; (TC3xx devices without AGBT: VSS)
221	VEXT	Vx	4068531	7241336	Supply Voltage
222	VSS	Vx	3979071	7241337	Supply Voltage
223	AGBTTXN (VSS)	AGBT_TX / VEXT	3879599	7250841	Off-chip driver output PAD of the 2.5Gbps transmitter, negative pole AGBT Output; (TC3xx devices without AGBT: VSS)
224	AGBTTXP (VSS)	AGBT_TX / VEXT	3798509	7250841	Off-chip driver output PAD of the 2.5Gbps transmitter, positive pole AGBT Output; (TC3xx devices without AGBT: VSS)
225	AGBTERR (VSS)	FAST / PD / VEXT	3608311	7250702	Input PAD for CRC error from FPGA. AGBT Input; (TC3xx devices without AGBT: VSS)
226	VSS	Vx	3464001	7241292	Supply Voltage
227	VDD	Vx	3417003	7082334	Supply Voltage
228	VDD	Vx	3295503	7241292	Supply Voltage
229	VEVRSB	Vx	3189501	7082334	Supply Voltage
230	VEVRSB	Vx	3125997	7241292	Supply Voltage
231	P33.0	SLOW / PU1 / VEVRSB / ES5	3078999	7082334	General-purpose I/O
232	VSS	Vx	3032001	7241292	Supply Voltage
233	VDD	Vx	2933001	7082334	Supply Voltage
234	VSS	Vx	2886003	7241292	Supply Voltage
235	P33.1	SLOW / PU1 / VEVRSB / ES5	2781495	7082334	General-purpose I/O
236	P33.2	SLOW / PU1 / VEVRSB / ES5	2734497	7241292	General-purpose I/O
237	P33.3	SLOW / PU1 / VEVRSB / ES5	2687499	7082334	General-purpose I/O
238	P34.1	SLOW / PU1 / VEVRSB / ES5	2640501	7250796	General-purpose I/O

TC37xEXT Pin Definition and Functions Pad Position Configuration of
Table 2-71 Pad List (cont'd)

Number	Pad Name	Pad Type	X	Y	Comment
239	VDD	Vx	2541501	7082334	Supply Voltage
240	VSS	Vx	2494503	7241292	Supply Voltage
241	P33.4	SLOW / PU1 / VEVRSB / ES5	2380491	7082334	General-purpose I/O
242	P34.2	SLOW / PU1 / VEVRSB / ES	2333493	7250796	General-purpose I/O
243	P33.5	SLOW / PU1 / VEVRSB / ES5	2286495	7082334	General-purpose I/O
244	P34.3	SLOW / PU1 / VEVRSB / ES	2239497	7250796	General-purpose I/O
245	P33.6	SLOW / PU1 / VEVRSB / ES5	2192499	7082334	General-purpose I/O
246	P34.4	SLOW / PU1 / VEVRSB / ES	2145501	7250796	General-purpose I/O
247	VDD_1V2_FL CS	Vx	2098503	7082334	Supply Voltage
248	VSS	Vx	2051505	7241292	Supply Voltage
249	P34.5	FAST / PU1 / VEVRSB / ES	1947195	7250796	General-purpose I/O
250	P33.7	SLOW / PU1 / VEVRSB / ES5	1900197	7082334	General-purpose I/O
251	P33.8	FAST / HighZ / VEVRSB	1853199	7241292	General-purpose I/O
252	P33.9	SLOW / PU1 / VEVRSB / ES5	1806201	7082334	General-purpose I/O
253	VSS	Vx	1713501	7241292	Supply Voltage
254	VDD	Vx	1666503	7082334	Supply Voltage
255	VEVRSB	Vx	1578519	7250796	Supply Voltage
256	P33.10	FAST / PU1 / VEVRSB / ES5	1531521	7082334	General-purpose I/O
257	P33.14	FAST / PU1 / VEVRSB / ES5	1451907	7250796	General-purpose I/O
258	P33.11	FAST / PU1 / VEVRSB / ES5	1352907	7241292	General-purpose I/O

TC37xEXT Pin Definition and Functions Pad Position Configuration of
Table 2-71 Pad List (cont'd)

Number	Pad Name	Pad Type	X	Y	Comment
259	P33.15	SLOW / PU1 / VEVRSB / ES5	1305909	7088328	General-purpose I/O
260	P33.12	FAST / PU1 / VEVRSB / ES5	1258911	7241292	General-purpose I/O
261	P33.13	FAST / PU1 / VEVRSB / ES5	1211913	7082334	General-purpose I/O
262	VSS	Vx	1164915	7241292	Supply Voltage
263	VDD	Vx	1038501	7082334	Supply Voltage
264	VSS	Vx	977301	7241292	Supply Voltage
265	VSS	Vx	876501	7241292	Supply Voltage
266	P32.0	SLOW / PU1 / VEXT / ES	771597	7241292	General-purpose I/O
267	VGATE1N	Vx	724599	7082334	DCDC N ch. MOSFET gate driver output
268	P32.1	SLOW / PU1 / VEXT / ES	677601	7241292	General-purpose I/O
269	VGATE1P	Vx	627201	7082334	DCDC P ch. MOSFET gate driver output
270	P32.2	SLOW / PU1 / VEXT / ES	576801	7241292	General-purpose I/O
271	P32.3	SLOW / PU1 / VEXT / ES	526401	7082334	General-purpose I/O
272	P32.4	FAST / PU1 / VEXT / ES	476001	7241292	General-purpose I/O
273	P32.5	SLOW / PU1 / VEXT / ES	425601	7088328	General-purpose I/O
274	P32.6	SLOW / PU1 / VEXT / ES	356301	7250796	General-purpose I/O
275	P32.7	SLOW / PU1 / VEXT / ES	255951	7250796	General-purpose I/O
276	VDD	Vx	175644	7169301	Supply Voltage
277	VSS	Vx	185148	7068501	Supply Voltage
278	VSS	Vx	185148	6967701	Supply Voltage
279	VEXT	Vx	185148	6866901	Supply Voltage
280	P23.0	SLOW / PU1 / VEXT / ES	344106	6766101	General-purpose I/O
281	P23.1	FAST / PU1 / VEXT / ES	185148	6719103	General-purpose I/O

TC37xEXT Pin Definition and Functions Pad Position Configuration of
Table 2-71 Pad List (cont'd)

Number	Pad Name	Pad Type	X	Y	Comment
282	P23.2	RFAST / PU1 / VFLEX2 / ES	344106	6616683	General-purpose I/O
283	VFLEX	Vx	175644	6569685	Supply Voltage
284	P23.3	RFAST / PU1 / VFLEX2 / ES	344106	6494481	General-purpose I/O
285	VSS	Vx	185148	6447483	Supply Voltage
286	P23.4	RFAST / PU1 / VFLEX2 / ES	344106	6372279	General-purpose I/O
287	VDD	Vx	175644	6325281	Supply Voltage
288	P22.12	RFAST / PU1 / VFLEX2 / ES	322614	6209577	General-purpose I/O
289	VSS	Vx	185148	6122079	Supply Voltage
290	P22.10	RFAST / PU1 / VFLEX2 / ES	338112	6046875	General-purpose I/O
291	VFLEX	Vx	175644	5999877	Supply Voltage
292	P22.11	RFAST / PU1 / VFLEX2 / ES	338112	5924673	General-purpose I/O
293	VSS	Vx	185148	5877675	Supply Voltage
294	P22.7	SLOW / RGMII_Input / PU1 / VFLEX2 / ES	338112	5830677	General-purpose I/O
295	P23.5	FAST / RGMII_Input / PU1 / VFLEX2 / ES	185148	5764059	General-purpose I/O
296	P23.7	SLOW / RGMII_Input / PU1 / VFLEX2 / ES	338112	5713461	General-purpose I/O
297	VFLEX	Vx	185148	5662863	Supply Voltage
298	P23.6	SLOW / RGMII_Input / PU1 / VFLEX2 / ES	338112	5615865	General-purpose I/O
299	P22.4	SLOW / RGMII_Input / PU1 / VFLEX2 / ES	175644	5565267	General-purpose I/O
300	P22.6	SLOW / RGMII_Input / PU1 / VFLEX2 / ES	338112	5514669	General-purpose I/O

TC37xEXT Pin Definition and Functions Pad Position Configuration of
Table 2-71 Pad List (cont'd)

Number	Pad Name	Pad Type	X	Y	Comment
301	VSS	Vx	185148	5464071	Supply Voltage
302	P22.5	SLOW / RGMII_Input / PU1 / VFLEX2 / ES	338112	5417073	General-purpose I/O
303	P22.8	SLOW / PU1 / VFLEX2 / ES	175644	5366475	General-purpose I/O
304	P22.9	SLOW / PU1 / VFLEX2 / ES	322614	5319477	General-purpose I/O
305	P22.0	LVDS_TX / FAST / PU1 / VFLEX2 / ES6	185148	5207976	General-purpose I/O
306	P22.1	LVDS_TX / FAST / PU1 / VFLEX2 / ES6	185148	5113980	General-purpose I/O
307	VDDP_3V3_F LANA1	—	344106	4966263	Supply Voltage
308	VSS	Vx	185148	4919265	Supply Voltage
309	VDD	Vx	338112	4872267	Supply Voltage
310	P22.2	LVDS_TX / FAST / PU1 / VEXT / ES6	344106	4760766	General-purpose I/O
311	P22.3	LVDS_TX / FAST / PU1 / VEXT / ES6	344106	4666770	General-purpose I/O
312	VEXT	Vx	185148	4555269	Supply Voltage
313	VEXT	Vx	344106	4508271	Supply Voltage
314	VEXT	Vx	185148	4461273	Supply Voltage
315	RESERVED	Vx	185148	4364001	Must be bonded to VSS
316	VDD	Vx	344106	4317003	Supply Voltage
317	VSS	Vx	185148	4256001	Supply Voltage
318	VDD	Vx	344106	4184001	Supply Voltage
319	VDD	Vx	362646	4071951	Supply Voltage
320	VSS	—	185148	4022541	Supply Voltage
321	XTAL1	XTAL / VEXT	185148	3865392	XTAL pad1 XTAL1. Main Oscillator/PLL/Clock Generator Input.
322	XTAL2	XTAL / VEXT	185148	3766392	XTAL pad2 XTAL2. Main Oscillator/PLL/Clock Generator OUTPUT
323	VSS	—	185148	3609243	Supply Voltage

TC37xEXT Pin Definition and Functions Pad Position Configuration of
Table 2-71 Pad List (cont'd)

Number	Pad Name	Pad Type	X	Y	Comment
324	VEXT	Vx	362646	3559833	Supply Voltage
325	VEXT	Vx	185148	3423501	Supply Voltage
326	VDD	Vx	185148	3261501	Supply Voltage
327	VSS	Vx	185148	3135501	Supply Voltage
328	P21.0	LVDS_RX / FAST / PU1 / VEXT / ES	344106	3044646	General-purpose I/O
329	P21.1	LVDS_RX / FAST / PU1 / VEXT / ES	344106	2950650	General-purpose I/O
330	VSS	Vx	185148	2875599	Supply Voltage
331	P21.2	LVDS_RX / FAST / PU1 / VEXT / ES	344106	2800548	General-purpose I/O
332	P21.3	LVDS_RX / FAST / PU1 / VEXT / ES	344106	2706552	General-purpose I/O
333	VSS	Vx	185148	2631501	Supply Voltage
334	VDD	Vx	185148	2519001	Supply Voltage
335	P21.4	LVDS_TX / FAST / PU1 / VEXT / ES6	344106	2363976	General-purpose I/O
336	P21.5	LVDS_TX / FAST / PU1 / VEXT / ES6	344106	2269980	General-purpose I/O
337	DAPE2	FAST / PD2 / VEXT	175644	2158479	DAPE: DAPE2 Data I/O DAPE: DAPE2 Data I/O (PD Devices: VSS)
338	P21.6/TDI	FAST / PD / PU2 / VEXT / ES3	344106	2111481	General-purpose I/O PD during Reset and in DAP/DAPE or JTAG mode. After Reset release and when not in DAP/DAPE or JTAG mode: PU. In Standby mode: HighZ. DAPE: DAPE1 Data I/O.
339	DAPE1	FAST / PD2 / VEXT	175644	2064483	DAPE: DAPE1 Data I/O DAPE: DAPE1 Data I/O (PD Devices: VSS)
340	TMS	FAST / PD2 / VEXT	344106	2017485	JTAG Module State Machine Control Input TMS: JTAG Module State Machine Control Input. DAP: DAP1 Data I/O.

TC37xEXT Pin Definition and Functions Pad Position Configuration of
Table 2-71 Pad List (cont'd)

Number	Pad Name	Pad Type	X	Y	Comment
341	DAPE0	FAST / PD2 / VEXT	175644	1970487	DAPE: DAPE0 Clock Input DAPE: DAPE0 clock input (PD Devices: NC)
342	P21.7/TDO	FAST / PU2 / VEXT / ES4	344106	1923489	General-purpose I/O DAP: DAP2 Data I/O; DAPE: DAPE2 Data I/O.
343	VSS	Vx	185148	1876491	Supply Voltage
344	$\overline{\text{TRST}}$	FAST / PU2 / VEXT	344106	1829493	JTAG Module Reset/Enable Input TRST_N: JTAG Module Reset/Enable Input. DAPE: DAPE0 Clock Input
345	TCK	FAST / PD2 / VEXT	185148	1782495	JTAG Module Clock Input TCK: JTAG Module Clock Input. DAP: DAP0 Clock Input.
346	P20.0	FAST / PU1 / VEXT / ES	344106	1735497	General-purpose I/O
347	VEXT	Vx	185148	1688499	Supply Voltage
348	P20.1	SLOW / PU1 / VEXT / ES	344106	1641501	General-purpose I/O
349	VSS	Vx	185148	1542501	Supply Voltage
350	VDD	Vx	185148	1434501	Supply Voltage
351	P20.2	S / PU / VEXT	344106	1334493	General-purpose I/O This pin is latched at power on reset release to enter test mode.
352	P20.3	SLOW / PU1 / VEXT / ES	185148	1287495	General-purpose I/O
353	$\overline{\text{ESR1}}$	FAST / PU1 / VEXT	344106	1240497	ESR1 Port Pin input - can be used to trigger a reset or an NMI ESR1: External System Request Reset 1. Default NMI function. See also SCU chapter for details. Default after power-on can be different. See also SCU chapter 'Reset Control Unit' and SCU_IOCRR register description. PMS_EVRWUP: EVR Wakeup Pin

TC37xEXT Pin Definition and Functions Pad Position Configuration of
Table 2-71 Pad List (cont'd)

Number	Pad Name	Pad Type	X	Y	Comment
354	$\overline{\text{PORST}}$	PORST / PD / VEXT	185148	1193499	PORST pin Power On Reset Input. Additional strong PD in case of power fail.
355	$\overline{\text{ESR0}}$	FAST / OD / VEXT	344106	1146501	ESR0 Port Pin input - can be used to trigger a reset or an NMI ESR0: External System Request Reset 0. Default configuration during and after reset is open-drain driver. The driver drives low during power-on reset. This is valid additionally after deactivation of PORST_N until the internal reset phase has finished. See also SCU chapter for details. Default after power-on can be different. See also SCU chapter 'Reset Control Unit' and SCU_IOCRR register description. PMS_EVRWUP: EVR Wakeup Pin
356	VSS	Vx	185148	1056501	Supply Voltage
357	VDD	Vx	344106	944001	Supply Voltage
358	VDD	Vx	185148	831501	Supply Voltage
359	P20.6	SLOW / PU1 / VEXT / ES	344106	725499	General-purpose I/O
360	P20.7	FAST / PU1 / VEXT / ES	185148	678501	General-purpose I/O
361	P20.8	FAST / PU1 / VEXT / ES	344106	628101	General-purpose I/O
362	P20.9	FAST / PU1 / VEXT / ES	185148	577701	General-purpose I/O
363	P20.10	FAST / PU1 / VEXT / ES	344106	527301	General-purpose I/O
364	P20.11	FAST / PU1 / VEXT / ES	185148	476901	General-purpose I/O
365	P20.12	FAST / PU1 / VEXT / ES	344106	426501	General-purpose I/O
366	P20.13	FAST / PU1 / VEXT / ES	185148	357201	General-purpose I/O
367	P20.14	FAST / PU1 / VEXT / ES	185148	256401	General-purpose I/O

TC37xEXT Pin Definition and Functions Pad Position Configuration of

Whenever in table of section 3 'Electrical Specification' the term 'neighbor pads' is used, the detailed definition is provided by [Figure 2-71](#). This statement is also valid for next/nearest neighbor pads. This statement is also valid for next/nearest neighbor pads.

In order to find out who is affecting operation on a target pad (interfering) a number of active close-neighbor pads (ACNP) has to be defined.

Finding close-neighbor pads.

The Pad Ring has four edges: bottom, left, top, right. Each edge is limited, i.e. it has two ends.

Each pad has two direct (first) neighbors unless it is located at the end of the edge. In that case it only has one neighbor. Similarly, each pad has two indirect (second) neighbors unless it or its first neighbor is located at the end of the edge. These first and second neighbors we will collectively call Close-Neighbor pads. Therefore each pad has 2 to 4 close-neighbor pads.

Finding close-neighbors can be done with the following sequence:

- 1.) Choose a target pad and lookup its "X" and "Y" coordinates in table [Figure 2-71](#).
- 2.) Find first and second neighbors by calculating "X" and "Y" distance from the selected pad. [Figure 2-71](#) is sorted by "Y" coordinate, which might help locate the 4 close-neighbor candidates (if the pad is near the edge, it might end up with less than 4 close-neighbors).

Defining active pads:

Pad is active if it is currently in use and if it doesn't have "Vxx" in the name.

Figuring out number of active close-neighbor pads follow next rules:

- If the first neighbor is active, then we count it and also check if second neighbor (on the same side of selected pad) is active.
- If the first neighbor is not active, then we do not check the second on the same side.

2.6 Legend

The data in this chapter 2 for TE and TX match with the file TC37xed_IO_Spirit_v2.0.0.1.25.xml.

Column "Ctrl.":

I = Input (for GPIO port lines with IOCR bit field Selection PCx = 0XXX_B)

O = Output (for GPIO port lines the 'O' represents in most cases the port HWOUT function)

O0 = Output with IOCR bit field selection PCx = 1X000_B

O1 = Output with IOCR bit field selection PCx = 1X001_B (ALT1)

O2 = Output with IOCR bit field selection PCx = 1X010_B (ALT2)

O3 = Output with IOCR bit field selection PCx = 1X011_B (ALT3)

O4 = Output with IOCR bit field selection PCx = 1X100_B (ALT4)

O5 = Output with IOCR bit field selection PCx = 1X101_B (ALT5)

O6 = Output with IOCR bit field selection PCx = 1X110_B (ALT6)

O7 = Output with IOCR bit field selection PCx = 1X111_B (ALT7)

Column "Buffer Type":

RFAST = Pad class RFAST (5V/3.3V)

FAST = Pad class FAST (5V/3.3V)

SLOW = Pad class SLOW (5V/3.3V)

LVDS_TX = Pad class LVDS Transmit

LVDS_RX = Pad class LVDS Receive

S = Pad class S (Analog Input overlaid with General Purpose Input)

D = Pad class D (Analog Input)

Porst = Porst input Pad

XTAL1 = XTAL1 input Pad

XTAL2 = XTAL2 input Pad

PU = with pull-up device connected during reset ($\overline{\text{PORST}} = 0$)

PU1 = with pull-up device connected during reset ($\overline{\text{PORST}} = 0$)¹⁾

PU2 = with pull-up device connected during startup and reset, HighZ in Standby mode

PD = with pull-down device connected during reset ($\overline{\text{PORST}} = 0$)

PD1 = with pull-down device connected during reset ($\overline{\text{PORST}} = 0$)¹⁾

PD2 = with pull-down device connected during startup and reset, HighZ in Standby mode

OD = open drain during reset ($\overline{\text{PORST}} = 0$)

ES = Supports Emergency Stop

ES1 = ES. ES can be overruled by VADC, control via P00_PCSR

ES2 = ES. ES can be overruled by DXCPL - DAP over CAN physical layer, No overruling for DXCM - Debug over CAN message

ES3 = ES. ES can be overruled by JTAG mode if this pin is used as TDI

ES4 = ES. ES can be overruled by JTAG or Three Pin DAP mode

1) The default state of GPIOs (Px.y) during and after PORST active is controlled via HWCFG6 (P14.4). Pls. see also chapter PMS, HWCFG[6].

TC37xEXT Pin Definition and Functions Legend

ES5 = ES. ES can be overruled by the Standby Controller - SCR - if implemented. Overruling can be disabled via the control register P33_PCSR and P34_PCSR

ES6 = ES. On LVDS TX pads the ES affects the pads only in CMOS mode, not in LVDS mode. Thus, only when LPCRx.TX_EN selects the CMOS Mode, the output is switched off in the ES event

3 Electrical Specification

3.1 Parameter Interpretation

The parameters listed in this section partly represent the characteristics of the TC37xEXT and partly its requirements on the system. To aid interpreting the parameters easily when evaluating them for a design, they are marked with an two-letter abbreviation in column "Symbol":

- **CC**
Such parameters indicate **C**ontroller **C**haracteristics which are a distinctive feature of the TC37xEXT and must be regarded for a system design.
- **SR**
Such parameters indicate **S**ystem **R**equirements which must be provided by the microcontroller system in which the TC37xEXT designed in.

Electrical Specification Absolute Maximum Ratings

3.2 Absolute Maximum Ratings

Stresses above the values listed under “Absolute Maximum Ratings” may cause permanent damage to the device. This is a stress rating only and functional operation of the device at these or any other conditions above those indicated in the Operational Conditions of this specification is not implied. Exposure to absolute maximum rating conditions may affect device reliability.

Table 3-1 Absolute Maximum Ratings

Parameter	Symbol	Values			Unit	Note / Test Condition
		Min.	Typ.	Max.		
Storage Temperature	T_{ST} SR	-65	-	150	°C	upto 65h @ $T_J = 150^{\circ}\text{C}$
Voltage at V_{DD} power supply pins with respect to V_{SS} ^{1) 2)}	V_{DD} SR	-	-	1.65	V	upto 2.8h
		-	-	1.45	V	upto 72h
Voltage at V_{DDP3} power supply pins with respect to V_{SS}	V_{DDP3} SR	-	-	4.43	V	
Voltage at V_{DDM} , V_{EXT} , V_{FLEX} and V_{EVRSB} power supply pins with respect to V_{SS}	V_{DDM} SR	-	-	6.75	V	upto 2.8h
		-	-	5.6	V	upto 72h
Voltage on all analog and class S input pins with respect to V_{SS} ³⁾	V_{IN} SR	-0.7	-	6.75	V	
Voltage on all other input pins with respect to V_{SS} ³⁾	V_{IN} SR	-0.7	-	6.75	V	
Input current on any pin during overload condition ^{4) 5)}	I_{IN} SR	-10	-	10	mA	
Absolute maximum sum of all input circuit currents during overload condition. ⁴⁾	ΣI_{IN} SR	-100	-	100	mA	

- 1) Valid for cumulated for up to 2.8h and pulse forms followed a power supply switch on phase, where the rise and fall times are related to the system capacities and coils.
- 2) Due to EVRC output voltage oscillation during switch off phase V_{DD} can drop down to -0.72V. For V_{DD} an input level down to -0.72V during switch off phase will not cause any damage or reliability problem.
- 3) Voltages below V_{INmin} have no impact to the device reliability as long as the times and currents defined in section Pin Reliability in Overload for the affected pad(s) are not violated.
- 4) This parameter is an Absolute Maximum Rating. Exposure to Absolute Maximum Ratings for extended periods of time may damage the device.
- 5) The specified min. and max. values represent the current limits, which have to be maintained, in case of a short circuit condition on the output of any Fast, RFast, Slow and Class S pad, not being used during operation. This cover also output currents due to switching in operation for $C_L=200\text{pF}$.

3.3 Pin Reliability in Overload

When receiving signals from higher voltage devices, low-voltage devices experience overload currents and voltages that go beyond their own IO power supplies specification.

The following table defines overload conditions that will not cause any negative reliability impact if all the following conditions are met:

- full operation life-time is not exceeded
- **Operating Conditions** are met for
 - pad supply levels
 - temperature

If a pin current is out of the **Operating Conditions** but within the overload parameters, then the parameters functionality of this pin as stated in the Operating Conditions can no longer be guaranteed. Operation is still possible in most cases but with relaxed parameters.

Table 3-2 Overload Parameters

Parameter	Symbol	Values			Unit	Note / Test Condition
		Min.	Typ.	Max.		
Input current on any digital pin during overload condition	I_{IN}	-5	-	5	mA	except LVDS pins
		-15 ¹⁾	-	15 ¹⁾	mA	except LVDS pins; limited to max. 20 pulses with 1ms pulse length
Input current on LVDS pin during overload condition	I_{INLVDS}	-3	-	3	mA	
Input current on analog input pin during overload condition	I_{INANA}	-3	-	3	mA	
		-5	-	5	mA	limited to 60h over lifetime
Absolute sum of all analog input currents for analog inputs during overload condition	I_{INSA}	-20	-	20	mA	
Absolute maximum sum of all input circuit currents during overload condition (digital and analog combined)	ΣI_{INS}	-100	-	100	mA	
Signal voltage over/undershoot at GPIOs	V_{OUS}	$V_{SS} - 2$	-	$V_{EXT/FLEX/FLEX2} + 2$	V	limited to 60h over lifetime; Valid for non LVDS and analog pads
Sum of all inactive device pin currents	I_{IDS}	-100	-	100	mA	
Static pin output current	$I_{OUT\ CC}$	-	-	2.5	mA	100% duty cycle; output driver = medium
		-	-	5	mA	100% duty cycle; output driver = strong

Electrical Specification Pin Reliability in Overload
Table 3-2 Overload Parameters (cont'd)

Parameter	Symbol	Values			Unit	Note / Test Condition
		Min.	Typ.	Max.		
Overload coupling factor for digital inputs, negative	$K_{OV\text{DN}} \text{ CC}$	-	-	$3 \cdot 10^{-4}$		Overload injected on GPIO non LVDS pad and affecting neighbor fast pads; $-5\text{mA} < I_{\text{IN}} < 0\text{mA}$
		-	-	$2 \cdot 10^{-3}$		Overload injected on GPIO non LVDS pad and affecting neighbor slow pads VGASTE1N and VGATE1P; $-5\text{mA} < I_{\text{IN}} < 0\text{mA}$
		-	-	$1 \cdot 10^{-4}$		Overload injected on GPIO non LVDS pad and affecting neighbor slow pads; $-5\text{mA} < I_{\text{IN}} < 0\text{mA}$
		-	-	0.8		Overload injected on LVDS RX pad and affecting neighbor LVDS pads
		-	-	0.5		Overload injected on LVDS TX pad and affecting neighbor LVDS pads
Overload coupling factor for digital inputs, positive	$K_{OV\text{DP}} \text{ CC}$	-	-	$1.5 \cdot 10^{-3}$		Overload injected on GPIO non LVDS pad and affecting neighbor GPIO non LVDS pads
		-	-	1		Overload injected on LVDS RX pad and affecting neighbor LVDS pads
		-	-	$5 \cdot 10^{-3}$		Overload injected on LVDS TX pad and affecting neighbor LVDS pads
Overload coupling factor for analog inputs, negative ²⁾	$K_{OV\text{AN}} \text{ CC}$	-	-	$1 \cdot 10^{-4}$		Analog inputs overlaid with slow pads or pull down diagnostics; $-5\text{mA} < I_{\text{IN}} < 0\text{mA}$
		-	-	$1 \cdot 10^{-5}$		else; $-5\text{mA} < I_{\text{IN}} < 0\text{mA}$

Electrical Specification Pin Reliability in Overload

Table 3-2 Overload Parameters (cont'd)

Parameter	Symbol	Values			Unit	Note / Test Condition
		Min.	Typ.	Max.		
Overload coupling factor for analog inputs, positive ²⁾	$K_{OVAP\ CC}$	-	-	$2 \cdot 10^{-4}$		Analog inputs overlaid with slow pads or pull down diagnostics; $0\text{mA} < I_{IN} < 5\text{mA}$
		-	-	$2 \cdot 10^{-5}$		else; $0\text{mA} < I_{IN} < 5\text{mA}$

1) Reduced VADC / DSADC result accuracy and / or GPIO input levels (V_{IL} and V_{IH}) can differ from specified parameters.

2) Overload coupling on analog inputs is caused by parasitic effects between pads, input multiplexers and surrounding structures.

The given parameters have been verified for all permutations of channels. Also watch multiple connections of a pin to several channels.

3.4 Operating Conditions

The following operating conditions must not be exceeded in order to ensure correct operation and reliability of the TC37xEXT. All parameters specified in the following tables refer to these operating conditions, unless otherwise noticed.

Digital supply voltages applied to the TC37xEXT must be static regulated voltages.

All parameters specified in the following tables refer to these operating conditions (see table below), unless otherwise noticed in the Note / Test Condition column.

Table 3-3 Operating Conditions

Parameter	Symbol	Values			Unit	Note / Test Condition
		Min.	Typ.	Max.		
SRI frequency	f_{SRI} SR	-	-	300	MHz	
CPU Frequency (All CPUs)	f_{CPUx} SR	-	-	300	MHz	
PLL0 output frequency	f_{PLL0} SR	20	-	300	MHz	
SPB frequency	f_{SPB} SR	-	-	100	MHz	
FSI2 frequency	f_{FSI2} SR	-	-	300	MHz	
FSI frequency	f_{FSI} SR	20	-	100	MHz	
GTM frequency	f_{GTM} SR	-	-	200	MHz	
STM frequency	f_{STM} SR	-	-	100	MHz	
ERAY frequency	f_{ERAY} SR	-	80	-	MHz	
BBB frequency	f_{BBB} SR	-	-	150	MHz	
VADC frequency	f_{ADC} SR	-	-	160	MHz	
ASCLIN Operating Frequency	$f_{ASCLINx}$ SR	-	-	200	MHz	
CAN frequency	f_{CAN} SR	-	-	80	MHz	
I2C frequency	f_{I2C} SR	-	-	100	MHz	
Operating MSC Frequency	f_{MSC} SR	-	-	200	MHz	
PLL1 output frequency from PER PLL	f_{PLL1} SR	20	-	320	MHz	
PLL2 output frequency from PER PLL	f_{PLL2} SR	20	-	200	MHz	
QSPI Frequency	f_{QSPI} SR	-	-	200	MHz	
ADAS clock frequency	f_{ADAS} CC	200	-	300	MHz	
MCANH frequency	f_{MCANH} CC	-	-	100	MHz	
GETH frequency	f_{GETH} CC	150	-	200	MHz	
Ambient Temperature	T_A SR	-40	-	125	°C	valid for all SAK products
		-40	-	150	°C	valid for all SAL products with package
		-40	-	170	°C	valid for all SAL products without package

Electrical Specification Operating Conditions
Table 3-3 Operating Conditions (cont'd)

Parameter	Symbol	Values			Unit	Note / Test Condition
		Min.	Typ.	Max.		
Junction Temperature	T_J SR	-40	-	150	°C	valid for all SAK products
		-40	-	170	°C	valid for all SAL products
Core Supply Voltage	V_{DD} SR	1.125 ¹⁾	1.25	1.375 ²⁾	V	
ADC analog supply voltage	V_{DDM} SR	2.97	5.0	5.5 ³⁾	V	
Digital external supply voltage for pads and EVR	V_{EXT} SR	4.5	5.0	5.5 ³⁾	V	Nominal 5V Pad / Port Pin supply range. 5V pad parameters are valid.
		2.97	3.3	3.63	V	Nominal 3.3V Pad / Port Pin supply range with VDDP3 supplied externally and EVR33 inactive. 3.3V pad parameters are valid.
		3.6	-	4.5	V	Flash configured in cranking mode; Flash read operation with reduced performance. EVR33 active in low voltage mode. 3.3V pad parameters are valid.
		2.97	-	3.6	V	Incase EVR33 is active, Flash configured in sleep mode and execution switched to RAM. 3.3V pad parameters are valid.
Digital supply voltage for Flex port	V_{FLEX} SR	2.97	-	4.0	V	3.3V pad parameters are valid; also valid for V_{FLEX2}
		4.5	5.0	5.5 ³⁾	V	5V pad parameters are valid; also valid for V_{FLEX2}
Digital supply voltage for Flash	V_{DDP3} SR	2.97	3.3	3.63 ⁴⁾	V	
		2.6	-	3.63	V	Flash configured in cranking mode; Flash read operation with reduced performance.
Digital ground voltage	V_{SS} SR	0	-	-	V	
Analog ground voltage for V_{DDM}	V_{SSM} CC	-0.1	0	0.1	V	

Electrical Specification Operating Conditions
Table 3-3 Operating Conditions (cont'd)

Parameter	Symbol	Values			Unit	Note / Test Condition
		Min.	Typ.	Max.		
Digital external supply voltage for EVR and during Standby mode	$V_{EVR\text{SB}}$ SR	2.97 ⁵⁾	-	5.5	V	
Voltage to ensure defined pad states	$V_{DD\text{PPA}}$ CC	1.3 ⁶⁾	-	-	V	
Digital supply voltage for Flex2 port	$V_{\text{FLEX}2}$ SR	2.97	3.3	3.63	V	3.3V pad parameters are valid
		3.63	5	5.5	V	5V pad parameters are valid

- 1) For V_{DD} $1.08\text{V} \leq V_{\text{DD}} < 1.125\text{V}$ operation is still possible but with relaxed parameters.
- 2) Voltage overshoot to 1.69V is permissible, provided the duration is less than 2h cumulated. Reduced ADC accuracy and leakage is increased.
- 3) Voltage overshoot to 6.5V is permissible, provided the duration is less than 2h cumulated. Reduced ADC accuracy and leakage is increased.
- 4) Voltage overshoot to 4.29V is permissible, provided the duration is less than 2h cumulated. Reduced ADC accuracy and leakage is increased.
- 5) $V_{\text{EVR\text{SB}}}$ supply voltage can drop down upto 2.6V during Standby mode. It is required to have a capacitor of 100nF on $V_{\text{EVR\text{SB}}}$ supply pin.
- 6) HWCFG[6] pin is latched and pull-up or tristate is activated at Port pins when VEXT has reached this level.

Limitation of Supply Voltage over Time

The maximum operation voltage for $V_{\text{EXT/FLEX/DDM}}$ supply rails is limited over the complete lifetime.

The following voltage profile is an example. Application specific voltage profiles need to be aligned and approved by Infineon Technologies for the fulfillment of quality and reliability targets.

Table 3-4 Example Voltage Profile

$V_{\text{EXT/FLEX/DDM}}$	Duration [h]
$5.4\text{V} < V_{\text{EXT/FLEX/DDM}} \leq 5.5\text{V}$	$\leq 5\%$ of lifetime
$5.15\text{V} < V_{\text{EXT/FLEX/DDM}} \leq 5.4\text{V}$	$\leq 15\%$ of lifetime
$4.85\text{V} < V_{\text{EXT/FLEX/DDM}} \leq 5.15\text{V}$	$\leq 60\%$ of lifetime
$4.6\text{V} < V_{\text{EXT/FLEX/DDM}} \leq 4.85\text{V}$	$\leq 15\%$ of lifetime
$4.5\text{V} < V_{\text{EXT/FLEX/DDM}} \leq 4.6\text{V}$	$\leq 5\%$ of lifetime

The maximum operation voltage for V_{DD} supply rails is limited over the complete lifetime.

The following voltage profile is an example. Application specific voltage profiles need to be aligned and approved by Infineon Technologies for the fulfillment of quality and reliability targets.

Table 3-5 Example Voltage Profile

V_{DD}	Duration [h]
$1.325\text{V} < V_{\text{DD}} \leq 1.375\text{V}$	$\leq 5\%$ of lifetime
$1.275\text{V} < V_{\text{DD}} \leq 1.325\text{V}$	$\leq 15\%$ of lifetime
$1.225\text{V} < V_{\text{DD}} \leq 1.275\text{V}$	$\leq 60\%$ of lifetime

Electrical Specification Operating Conditions

Table 3-5 Example Voltage Profile

V_{DD}	Duration [h]
$1.175 \text{ V} < V_{DD} \leq 1.225 \text{ V}$	$\leq 15\%$ of lifetime
$1.125 \text{ V} < V_{DD} \leq 1.175 \text{ V}$	$\leq 5\%$ of lifetime

3.5 5 V / 3.3 V switchable Pads

Pad classes slow GPIO and fast GPIO support both Automotive Level (AL) or TTL level (TTL) operation. Parameters are defined for AL operation and degrade in TTL operation.

Table 3-6 $\overline{\text{PORST}}$ Pad

Parameter	Symbol	Values			Unit	Note / Test Condition
		Min.	Typ.	Max.		
$\overline{\text{PORST}}$ pad Output current	$I_{\text{PORST CC}}$	13	-	-	mA	$V_{\text{EXT}} = 2.97\text{V}; V_{\text{PORST}} = 0.9\text{V}$
Spike filter always blocked pulse duration	$t_{\text{SF1 CC}}$	-	-	80	ns	
Spike filter pass-through blocked pulse duration	$t_{\text{SF2 CC}}$	260	-	-	ns	without additional $\overline{\text{PORST}}$ Digital Filter active ($\text{PORSTDF} = 0$).
Input hysteresis ¹⁾	$HYS \text{ CC}$	$0.055 * V_{\text{EXT}}$	-	-	V	non of the neighbor pads are used as output;TTL (degraded, used for CIF)
Pull-down current ²⁾	$I_{\text{PDL CC}}$	-	-	130	μA	V_{IH} ; TTL (degraded, used for CIF)
		15	-	-	μA	V_{IL} ; TTL (degraded, used for CIF)
Input leakage current	$I_{\text{OZ CC}}$	-450	-	450	nA	$T_J \leq 150^\circ\text{C}; (0.1 * V_{\text{EXT}}) < V_{\text{IN}} < (0.9 * V_{\text{EXT}})$
		-500	-	500	nA	$T_J \leq 150^\circ\text{C}$; else
		-900	-	900	nA	$T_J \leq 170^\circ\text{C}; (0.1 * V_{\text{EXT}}) < V_{\text{IN}} < (0.9 * V_{\text{EXT}})$
		-950	-	950	nA	$T_J \leq 170^\circ\text{C}$; else
Input high voltage level	$V_{\text{IH SR}}$	1.4	-	-	V	TTL (degraded, used for CIF); $V_{\text{EXT}} = 2.97\text{V}$
		2.0	-	-	V	TTL; $V_{\text{EXT}} = 4.5\text{V}$
Input low voltage level	$V_{\text{IL SR}}$	-	-	0.5	V	TTL (degraded, used for CIF); $V_{\text{EXT}} = 2.97\text{V}$
		-	-	0.8	V	TTL; $V_{\text{EXT}} = 4.5\text{V}$
Pin capacitance	$C_{\text{IO CC}}$	-	2	3	pF	in addition 2.5pF from package to be added

1) Hysteresis is implemented to avoid metastable states and switching due to internal ground bounce. It can't be guaranteed that it suppresses switching due to external system noise.

2) Values for Pull-down resistor is defined via parameter R_{MDD} in table VADC 5V.

Electrical Specification 5 V / 3.3 V switchable Pads
Table 3-7 Fast 5V GPIO

Parameter	Symbol	Values			Unit	Note / Test Condition
		Min.	Typ.	Max.		
On-Resistance of pad output	R_{DSON} CC	125	225	320	Ohm	medium driver; $I_{\text{OH/OL}} = 2\text{mA}$
		31	55	80	Ohm	strong driver; $I_{\text{OH/OL}} = 8\text{mA}$
Rise / Fall time ^{1) 2)}	t_{RF} CC	1.6	-	3.2	ns	$C_{\text{L}} = 25\text{pF}$; driver = strong sharp edge; from 0.2 * $V_{\text{EXT/FLEX/FLEX2/EVRSB}}$ to 0.8 * $V_{\text{EXT/FLEX/FLEX2/EVRSB}}$
		$4+0.55 \cdot C_{\text{L}}$	$4+0.75 \cdot C_{\text{L}}$	$12+1.0 \cdot C_{\text{L}}$	ns	driver = medium; $C_{\text{L}} \leq 200\text{pF}$
		$1.0+0.18 \cdot C_{\text{L}}$	$2.5+0.27 \cdot C_{\text{L}}$	$5.0+0.35 \cdot C_{\text{L}}$	ns	driver = strong edge = medium; $C_{\text{L}} \leq 200\text{pF}$
		$0.5+0.08 \cdot C_{\text{L}}$	$0.5+0.11 \cdot C_{\text{L}}$	$1.0+0.17 \cdot C_{\text{L}}$	ns	driver = strong edge = sharp ; $C_{\text{L}} \leq 200\text{pF}$
Asymmetry of sending	$t_{\text{TX_ASYM}}$ CC	-1	-	1	ns	C_{L} ; valid for all data rates excluding clock tolerance
Input frequency	f_{IN} CC	-	-	160	MHz	
Input hysteresis ³⁾	HYS CC	0.09 * $V_{\text{EXT/FLEX/FLEX2/EVRSB}}$	-	-	V	non of the neighbor pads are used as output; AL
		0.075 * $V_{\text{EXT/FLEX/FLEX2/EVRSB}}$	-	-	V	non of the neighbor pads are used as output; TTL
		75	-	-	mV	two of the neighbor pads are used as output with driver=strong and edge=sharp; AL
Pull-up current ⁴⁾	I_{PUH} CC	30	-	-	μA	V_{IH} ; AL or TTL
		-	-	130	μA	V_{IL} ; AL or TTL
Pull-down current ⁵⁾	I_{PDL} CC	-	-	130	μA	V_{IH} ; AL or TTL
		30	-	-	μA	V_{IL} ; AL
		28	-	-	μA	V_{IL} ; TTL

Electrical Specification 5 V / 3.3 V switchable Pads
Table 3-7 Fast 5V GPIO (cont'd)

Parameter	Symbol	Values			Unit	Note / Test Condition
		Min.	Typ.	Max.		
Input leakage current	$I_{OZ\ CC}$	-1100	-	1100	nA	$T_J \leq 150^\circ\text{C}$; (0.1 * $V_{EXT/FLEX/FLEX2/EVRSB}$) < V_{IN} < (0.9 * $V_{EXT/FLEX/FLEX2/EVRSB}$)
		-2500	-	2500	nA	$T_J \leq 150^\circ\text{C}$; (0.1 * $V_{EXT/FLEX/FLEX2}$) < V_{IN} < (0.9 * $V_{EXT/FLEX/FLEX2}$) ; LVDS_TX / Fast pad type
		-6000	-	6000	nA	$T_J \leq 150^\circ\text{C}$; LVDS_RX / Fast pad type ; else
		-3200	-	3200	nA	$T_J \leq 150^\circ\text{C}$; LVDS_TX / Fast pad type ; else
		-1500	-	1500	nA	$T_J \leq 150^\circ\text{C}$; else
		-2000	-	2000	nA	$T_J \leq 170^\circ\text{C}$; (0.1 * $V_{EXT/FLEX/FLEX2/EVRSB}$) < V_{IN} < (0.9 * $V_{EXT/FLEX/FLEX2/EVRSB}$)
		-4000	-	4000	nA	$T_J \leq 170^\circ\text{C}$; (0.1 * $V_{EXT/FLEX/FLEX2}$) < V_{IN} < (0.9 * $V_{EXT/FLEX/FLEX2}$) ; LVDS_TX / Fast pad type
		-13500	-	13500	nA	$T_J \leq 170^\circ\text{C}$; LVDS_RX / Fast pad type ; else
		-5100	-	5100	nA	$T_J \leq 170^\circ\text{C}$; LVDS_TX / Fast pad type ; else
		-2500	-	2500	nA	$T_J \leq 170^\circ\text{C}$; else
Input high voltage level	$V_{IH\ SR}$	0.7 * $V_{EXT/FLEX/FLEX2/EVRSB}$	-	-	V	AL
		2.0	-	-	V	TTL
Input low voltage level	$V_{IL\ SR}$	-	-	0.44 * $V_{EXT/FLEX/FLEX2/EVRSB}$	V	AL
		-	-	0.8	V	TTL
Input low threshold variation	$V_{ILD\ SR}$	-50	-	50	mV	max. variation of 1ms; $V_{EXT/FLEX/FLEX2/EVRSB} =$ constant; AL

Electrical Specification 5 V / 3.3 V switchable Pads
Table 3-7 Fast 5V GPIO (cont'd)

Parameter	Symbol	Values			Unit	Note / Test Condition
		Min.	Typ.	Max.		
Pin capacitance	C_{IO} CC	-	2	3	pF	in addition 2.5pF from package to be added
Pad set-up time to get an software update of the configuration active	t_{SET} CC	-	-	100	ns	

- 1) In the formulas the value of C_L needs to be entered in pF to obtain results in ns.
- 2) Rise / fall times are defined 10% - 90% of pad supply voltage.
- 3) Hysteresis is implemented to avoid metastable states and switching due to internal ground bounce. It can't be guaranteed that it suppresses switching due to external system noise.
- 4) Values for Pull-up resistor is defined via parameter R_{MDU} in table VADC 5V.
- 5) Values for Pull-down resistor is defined via parameter R_{MDD} in table VADC 5V.

Table 3-8 Fast 3.3V GPIO

Parameter	Symbol	Values			Unit	Note / Test Condition
		Min.	Typ.	Max.		
On-Resistance of pad output	R_{DSON} CC	125	225	320	Ohm	medium driver; $I_{OH/OL} = 2mA$
		31	55	80	Ohm	strong driver; $I_{OH/OL} = 8mA$
Rise / Fall time ^{1) 2)}	t_{RF} CC	1.6	-	4.5	ns	$C_L = 25pF$; driver = strong sharp edge; from 0.2 * $V_{EXT/FLEX/FLEX2/EVRSB}$ to 0.8 * $V_{EXT/FLEX/FLEX2/EVRSB}$
		-	-	5	ns	$C_L = 25pF$; driver = strong sharp edge; from 0.8V to 2.0V (RMII)
		$2+0.57 \cdot C_L$	$5.5+0.75 \cdot C_L$	$10+1.25 \cdot C_L$	ns	driver = medium; $C_L \leq 200pF$
		$1.5+0.18 \cdot C_L$	$1.5+0.28 \cdot C_L$	$8+0.4 \cdot C_L$	ns	driver = strong edge = medium; $C_L \leq 200pF$
		$0.75+0.08 \cdot C_L$	$0.75+0.11 \cdot C_L$	$2.5+0.21 \cdot C_L$	ns	driver = strong edge = sharp ; $C_L \leq 200pF$
Asymmetry of sending	t_{TX_ASYM} CC	-1	-	1	ns	C_L ; valid for all data rates excluding clock tolerance
Input frequency	f_{IN} CC	-	-	160	MHz	

Electrical Specification 5 V / 3.3 V switchable Pads
Table 3-8 Fast 3.3V GPIO (cont'd)

Parameter	Symbol	Values			Unit	Note / Test Condition
		Min.	Typ.	Max.		
Input hysteresis ³⁾	<i>HYS</i> CC	0.055 * $V_{EXT/FLEX/FLEX2/EVRSB}$	-	-	V	non of the neighbor pads are used as output; AL
		0.09 * $V_{EXT/FLEX/FLEX2/EVRSB}$	-	-	V	non of the neighbor pads are used as output; TTL
		0.055 * $V_{EXT/FLEX/FLEX2/EVRSB}$	-	-	V	non of the neighbor pads are used as output;TTL (degraded, used for CIF)
		125	-	-	mV	two of the neighbor pads are used as output with driver=strong and edge=sharp; AL
Pull-up current ⁴⁾	<i>I_{PUH}</i> CC	17	-	-	μA	V_{IH} ; AL and TTL (degraded, used for CIF)
		11	-	-	μA	V_{IH} ; TTL
		-	-	80	μA	V_{IL} ; AL and TTL and TTL (degraded, used for CIF)
Pull-down current ⁵⁾	<i>I_{PDL}</i> CC	-	-	105	μA	V_{IH} ; AL and TTL (degraded, used for CIF)
		-	-	115	μA	V_{IH} ; TTL
		19	-	-	μA	V_{IL} ; AL and TTL
		15	-	-	μA	V_{IL} ; TTL (degraded, used for CIF)

Electrical Specification 5 V / 3.3 V switchable Pads
Table 3-8 Fast 3.3V GPIO (cont'd)

Parameter	Symbol	Values			Unit	Note / Test Condition
		Min.	Typ.	Max.		
Input leakage current	$I_{OZ\ CC}$	-1100	-	1100	nA	$T_J \leq 150^\circ\text{C}$; (0.1 * $V_{EXT/FLEX/FLEX2/EVRSB}$) < V_{IN} < (0.9 * $V_{EXT/FLEX/FLEX2/EVRSB}$)
		-2500	-	2500	nA	$T_J \leq 150^\circ\text{C}$; (0.1 * $V_{EXT/FLEX/FLEX2}$) < V_{IN} < (0.9 * $V_{EXT/FLEX/FLEX2}$) ; LVDS_TX / Fast pad type
		-6000	-	6000	nA	$T_J \leq 150^\circ\text{C}$; LVDS_RX / Fast pad type ; else
		-3200	-	3200	nA	$T_J \leq 150^\circ\text{C}$; LVDS_TX / Fast pad type ; else
		-1500	-	1500	nA	$T_J \leq 150^\circ\text{C}$; else
		-2000	-	2000	nA	$T_J \leq 170^\circ\text{C}$; (0.1 * $V_{EXT/FLEX/FLEX2/EVRSB}$) < V_{IN} < (0.9 * $V_{EXT/FLEX/FLEX2/EVRSB}$)
		-4000	-	4000	nA	$T_J \leq 170^\circ\text{C}$; (0.1 * $V_{EXT/FLEX/FLEX2}$) < V_{IN} < (0.9 * $V_{EXT/FLEX/FLEX2}$) ; LVDS_TX / Fast pad type
		-13500	-	13500	nA	$T_J \leq 170^\circ\text{C}$; LVDS_RX / Fast pad type ; else
		-5100	-	5100	nA	$T_J \leq 170^\circ\text{C}$; LVDS_TX / Fast pad type ; else
		-2500	-	2500	nA	$T_J \leq 170^\circ\text{C}$; else
Input high voltage level	$V_{IH\ SR}$	0.7 * $V_{EXT/FLEX/FLEX2/EVRSB}$	-	-	V	AL
		2.0	-	-	V	TTL
		1.4	-	-	V	TTL (degraded, used for CIF)
Input low voltage level	$V_{IL\ SR}$	-	-	0.42 * $V_{EXT/FLEX/FLEX2/EVRSB}$	V	AL
		-	-	0.8	V	TTL
		-	-	0.5	V	TTL (degraded, used for CIF)
Input low/high voltage level	$V_{ILH\ SR}$	1.0	-	1.9	V	RGMII; no hysteresis available

Electrical Specification 5 V / 3.3 V switchable Pads
Table 3-8 Fast 3.3V GPIO (cont'd)

Parameter	Symbol	Values			Unit	Note / Test Condition
		Min.	Typ.	Max.		
Input low threshold variation	V_{ILD} SR	-33	-	33	mV	max. variation of 1ms; $V_{EXT/FLEX/FLEX2/EVRSB} =$ constant; AL
Pin capacitance	C_{IO} CC	-	2	3	pF	in addition 2.5pF from package to be added
Pad set-up time to get an software update of the configuration active	t_{SET} CC	-	-	100	ns	

- 1) In the formulas the value of C_L needs to be entered in pF to obtain results in ns.
- 2) Rise / fall times are defined 10% - 90% of pad supply voltage.
- 3) Hysteresis is implemented to avoid metastable states and switching due to internal ground bounce. It can't be guaranteed that it suppresses switching due to external system noise.
- 4) Values for Pull-up resistor is defined via parameter R_{MDU} in table VADC 5V.
- 5) Values for Pull-down resistor is defined via parameter R_{MDD} in table VADC 5V.

Table 3-9 Slow 5V GPIO

Parameter	Symbol	Values			Unit	Note / Test Condition
		Min.	Typ.	Max.		
On-Resistance of pad output	R_{DSON} CC	125	225	320	Ohm	medium driver; $I_{OH/OL}$ = 2mA
Rise / Fall time ^{1) 2)}	t_{RF} CC	$4+0.55 \cdot C_L$	$4+0.75 \cdot C_L$	$12+1 \cdot C_L$	ns	driver = medium edge = medium ; $C_L \leq 200$ pF
		$1.5+0.25 \cdot C_L$	$2.5+0.40 \cdot C_L$	$7+0.55 \cdot C_L$	ns	driver = medium edge = sharp ; $C_L \leq 200$ pF
Asymmetry of sending	t_{TX_ASYM} CC	-1	-	1	ns	C_L ; valid for all data rates excluding clock tolerance
Input frequency	f_{IN} CC	-	-	160	MHz	
Input hysteresis ³⁾	HYS CC	0.09 *	-	-	V	non of the neighbor pads are used as output; AL
		$0.075 \cdot \frac{V_{EXT/FLEX/FLEX2/EVRSB}}{V_{EXT/FLEX/FLEX2/EVRSB}}$	-	-	V	non of the neighbor pads are used as output; TTL
		75	-	-	mV	two of the neighbor pads are used as output with driver=strong and edge=sharp; AL

Electrical Specification 5 V / 3.3 V switchable Pads
Table 3-9 Slow 5V GPIO (cont'd)

Parameter	Symbol	Values			Unit	Note / Test Condition
		Min.	Typ.	Max.		
Pull-up current ⁴⁾	I_{PUH} CC	30	-	-	μA	V_{IH} ; AL or TTL; except VGATE1P; except VGATE1N and $T_J > 150^\circ\text{C}$
		-	-	130	μA	V_{IL} ; AL or TTL; except VGATE1P; except VGATE1N and $T_J > 150^\circ\text{C}$
Pull-down current ⁵⁾	I_{PDL} CC	-	-	130	μA	V_{IH} ; AL or TTL
		30	-	-	μA	V_{IL} ; AL
		28	-	-	μA	V_{IL} ; TTL
Input leakage current	I_{OZ} CC	-300	-	300	nA	$T_J \leq 150^\circ\text{C}$; (0.1 * $V_{EXT/FLEX/FLEX2/EVRSB}$) < $V_{IN} < (0.9 * V_{EXT/FLEX/FLEX2/EVRSB})$
		-400	-	400	nA	$T_J \leq 150^\circ\text{C}$; else
		-600	-	600	nA	$T_J \leq 170^\circ\text{C}$; (0.1 * $V_{EXT/FLEX/FLEX2/EVRSB}$) < $V_{IN} < (0.9 * V_{EXT/FLEX/FLEX2/EVRSB})$
		-750	-	750	nA	$T_J \leq 170^\circ\text{C}$; else
		-18000	-	18000	nA	P32.0 and P32.1; $T_J \leq 150^\circ\text{C}$
		-38000	-	38000	nA	P32.0 and P32.1; $T_J \leq 170^\circ\text{C}$
Input high voltage level	V_{IH} SR	0.7 * $V_{EXT/FLEX/FLEX2/EVRSB}$	-	-	V	AL
		2.0	-	-	V	TTL
Input low voltage level	V_{IL} SR	-	-	0.44 * $V_{EXT/FLEX/FLEX2/EVRSB}$	V	AL
		-	-	0.8	V	TTL
Input low threshold variation	V_{ILD} SR	-50	-	50	mV	max. variation of 1ms; $V_{EXT/FLEX/FLEX2/EVRSB} = \text{constant}$; AL
Pin capacitance	C_{IO} CC	-	2	3	pF	in addition 2.5pF from package to be added
Pad set-up time to get an software update of the configuration active	t_{SET} CC	-	-	100	ns	

1) In the formulas the value of C_L needs to be entered in pF to obtain results in ns.

Electrical Specification 5 V / 3.3 V switchable Pads

- 2) Rise / fall times are defined 10% - 90% of pad supply voltage.
- 3) Hysteresis is implemented to avoid metastable states and switching due to internal ground bounce. It can't be guaranteed that it suppresses switching due to external system noise.
- 4) Values for Pull-up resistor is defined via parameter R_{MDU} in table VADC 5V.
- 5) Values for Pull-down resistor is defined via parameter R_{MDD} in table VADC 5V.

Table 3-10 Slow 3.3V GPIO

Parameter	Symbol	Values			Unit	Note / Test Condition
		Min.	Typ.	Max.		
On-Resistance of pad output	R_{DSON} CC	125	225	320	Ohm	medium driver; $I_{OH/OL} = 2mA$
Rise / Fall time ^{1) 2)}	t_{RF} CC	$2+0.57 \cdot C_L$	$5.5+0.75 \cdot C_L$	$10+1.25 \cdot C_L$	ns	driver = medium edge = medium ; $C_L \leq 200pF$
		$2+0.30 \cdot C_L$	$3.5+0.50 \cdot C_L$	$5+0.70 \cdot C_L$	ns	driver = medium edge = sharp ; $C_L \leq 200pF$
Asymmetry of sending	t_{TX_ASYM} CC	-1	-	1	ns	C_L ; valid for all data rates excluding clock tolerance
Input frequency	f_{IN} CC	-	-	160	MHz	
Input hysteresis ³⁾	HYS CC	$0.055 \cdot V_{EXT/FLEX/FLEX2/EVRSB}$	-	-	V	non of the neighbor pads are used as output; AL
		$0.09 \cdot V_{EXT/FLEX/FLEX2/EVRSB}$	-	-	V	non of the neighbor pads are used as output; TTL
		$0.055 \cdot V_{EXT/FLEX/FLEX2/EVRSB}$	-	-	V	non of the neighbor pads are used as output;TTL (degraded, used for CIF)
		125	-	-	mV	two of the neighbor pads are used as output with driver=strong and edge=sharp; AL

Electrical Specification 5 V / 3.3 V switchable Pads
Table 3-10 Slow 3.3V GPIO (cont'd)

Parameter	Symbol	Values			Unit	Note / Test Condition
		Min.	Typ.	Max.		
Pull-up current ⁴⁾	I_{PUH} CC	17	-	-	μ A	V_{IH} ; AL and TTL (degraded, used for CIF); except VGATE1P; except VGATE1N and $T_J > 150^\circ\text{C}$
		11	-	-	μ A	V_{IH} ; TTL; except VGATE1P; except VGATE1N and $T_J > 150^\circ\text{C}$
		-	-	80	μ A	V_{IL} ; AL and TTL and TTL (degraded, used for CIF); except VGATE1P; except VGATE1N and $T_J > 150^\circ\text{C}$
Pull-down current ⁵⁾	I_{PDL} CC	-	-	105	μ A	V_{IH} ; AL and TTL (degraded, used for CIF)
		-	-	115	μ A	V_{IH} ; TTL
		19	-	-	μ A	V_{IL} ; AL and TTL
		15	-	-	μ A	V_{IL} ; TTL (degraded, used for CIF)
Input leakage current	I_{OZ} CC	-300	-	300	nA	$T_J \leq 150^\circ\text{C}$; (0.1 * $V_{EXT/FLEX/FLEX2/EVRSB}$) < V_{IN} < (0.9 * $V_{EXT/FLEX/FLEX2/EVRSB}$)
		-400	-	400	nA	$T_J \leq 150^\circ\text{C}$; else
		-600	-	600	nA	$T_J \leq 170^\circ\text{C}$; (0.1 * $V_{EXT/FLEX/FLEX2/EVRSB}$) < V_{IN} < (0.9 * $V_{EXT/FLEX/FLEX2/EVRSB}$)
		-750	-	750	nA	$T_J \leq 170^\circ\text{C}$; else
		-18000	-	18000	nA	P32.0 and P32.1; $T_J \leq 150^\circ\text{C}$
		-38000	-	38000	nA	P32.0 and P32.1; $T_J \leq 170^\circ\text{C}$
Input high voltage level	V_{IH} SR	0.7 * $V_{EXT/FLEX/FLEX2/EVRSB}$	-	-	V	AL
		2.0	-	-	V	TTL
		1.4	-	-	V	TTL (degraded, used for CIF)

Electrical Specification 5 V / 3.3 V switchable Pads
Table 3-10 Slow 3.3V GPIO (cont'd)

Parameter	Symbol	Values			Unit	Note / Test Condition
		Min.	Typ.	Max.		
Input low voltage level	V_{IL} SR	-	-	0.42 * $V_{EXT/FLEX/FLEX2/EVRSB}$	V	AL
		-	-	0.8	V	TTL
		-	-	0.5	V	TTL (degraded, used for CIF)
Input low/high voltage level	V_{ILH} SR	1.0	-	1.9	V	RGMII; no hysteresis available
Input low threshold variation	V_{ILD} SR	-33	-	33	mV	max. variation of 1ms; $V_{EXT/FLEX/FLEX2/EVRSB}$ = constant; AL
Pin capacitance	C_{IO} CC	-	2	3	pF	in addition 2.5pF from package to be added
Pad set-up time to get an software update of the configuration active	t_{SET} CC	-	-	100	ns	

- 1) In the formulas the value of C_L needs to be entered in pF to obtain results in ns.
- 2) Rise / fall times are defined 10% - 90% of pad supply voltage.
- 3) Hysteresis is implemented to avoid metastable states and switching due to internal ground bounce. It can't be guaranteed that it suppresses switching due to external system noise.
- 4) Values for Pull-up resistor is defined via parameter R_{MDU} in table VADC 5V.
- 5) Values for Pull-down resistor is defined via parameter R_{MDD} in table VADC 5V.

Table 3-11 RFast 5V GPIO

Parameter	Symbol	Values			Unit	Note / Test Condition
		Min.	Typ.	Max.		
On-Resistance of pad output	R_{DSON} CC	125	225	320	Ohm	medium driver; $I_{OH/OL}$ = 2mA
		31	55	80	Ohm	strong driver; $I_{OH/OL}$ = 8mA
Rise / Fall time ^{1) 2)}	t_{RF} CC	1.6	-	3.2	ns	C_L = 25pF; driver = strong sharp edge; from $0.2 * V_{FLEX/FLEX2}$ to $0.8 * V_{FLEX/FLEX2}$
		$4+0.55 * C_L$	$4+0.75 * C_L$	$12+1.0 * C_L$	ns	driver = medium; $C_L \leq 200$ pF
		$1.0+0.18 * C_L$	$2.5+0.27 * C_L$	$5.0+0.35 * C_L$	ns	driver = strong edge = medium; $C_L \leq 200$ pF
		$0.5+0.08 * C_L$	$0.5+0.11 * C_L$	$1.0+0.17 * C_L$	ns	driver = strong edge = sharp ; $C_L \leq 200$ pF
Asymmetry of sending	t_{TX_ASYM} CC	-0.5	-	0.5	ns	C_L ; valid for all data rates excluding clock tolerance

Electrical Specification 5 V / 3.3 V switchable Pads
Table 3-11 RFast 5V GPIO (cont'd)

Parameter	Symbol	Values			Unit	Note / Test Condition
		Min.	Typ.	Max.		
Input frequency	f_{IN} CC	-	-	160	MHz	
Input hysteresis ³⁾	HYS CC	0.09 * $V_{FLEX/FLEX2}$	-	-	V	non of the neighbor pads are used as output; AL
		0.075 * $V_{FLEX/FLEX2}$	-	-	V	non of the neighbor pads are used as output; TTL
		75	-	-	mV	two of the neighbor pads are used as output with driver=strong and edge=sharp; AL
Pull-up current ⁴⁾	I_{PUH} CC	30	-	-	μA	V_{IH} ; AL or TTL
		-	-	130	μA	V_{IL} ; AL or TTL
Pull-down current ⁵⁾	I_{PDL} CC	-	-	130	μA	V_{IH} ; AL or TTL
		30	-	-	μA	V_{IL} ; AL
		28	-	-	μA	V_{IL} ; TTL
Input leakage current	I_{OZ} CC	-1700	-	1700	nA	$T_J \leq 150^\circ\text{C}$; (0.1 * $V_{FLEX/FLEX2}$) < V_{IN} < (0.9 * $V_{FLEX/FLEX2}$)
		-2100	-	2100	nA	$T_J \leq 150^\circ\text{C}$; else
		-3000	-	3000	nA	$T_J \leq 170^\circ\text{C}$; (0.1 * $V_{FLEX/FLEX2}$) < V_{IN} < (0.9 * $V_{FLEX/FLEX2}$)
		-4000	-	4000	nA	$T_J \leq 170^\circ\text{C}$; else
Input high voltage level	V_{IH} SR	0.7 * $V_{FLEX/FLEX2}$	-	-	V	AL
		2.0	-	-	V	TTL
Input low voltage level	V_{IL} SR	-	-	0.44 * $V_{FLEX/FLEX2}$	V	AL
		-	-	0.8	V	TTL
Input low threshold variation	V_{ILD} SR	-50	-	50	mV	max. variation of 1ms; $V_{FLEX/FLEX2}$ = constant; AL
Pin capacitance	C_{IO} CC	-	2	3.5	pF	in addition 2.5pF from package to be added
Pad set-up time to get an software update of the configuration active	t_{SET} CC	-	-	100	ns	

1) In the formulas the value of C_L needs to be entered in pF to obtain results in ns.

Electrical Specification 5 V / 3.3 V switchable Pads

- 2) Rise / fall times are defined 10% - 90% of pad supply voltage.
- 3) Hysteresis is implemented to avoid metastable states and switching due to internal ground bounce. It can't be guaranteed that it suppresses switching due to external system noise.
- 4) Values for Pull-up resistor is defined via parameter R_{MDU} in table VADC 5V.
- 5) Values for Pull-down resistor is defined via parameter R_{MDD} in table VADC 5V.

Table 3-12 RFast 3.3V pad

Parameter	Symbol	Values			Unit	Note / Test Condition
		Min.	Typ.	Max.		
On-Resistance of pad output	R_{DSON} CC	8	20	30	Ohm	Driver = RGMII; $I_{OH/OL}$ = 8mA
		125	225	320	Ohm	medium driver; $I_{OH/OL}$ = 2mA
		31	55	80	Ohm	strong driver; $I_{OH/OL}$ = 8mA
Input Duty Cycle	f_D SR	47.5	50	52.5		
Rise / Fall time ^{1) 2)}	t_{RF} CC	1.6	-	4.5	ns	C_L = 25pF; driver = strong sharp edge; from $0.2 * V_{FLEX/FLEX2}$ to $0.8 * V_{FLEX/FLEX2}$
		-	-	5	ns	C_L = 25pF; driver = strong sharp edge; from 0.8V to 2.0V (RMII)
		-	-	1	ns	Driver = RGMII; from 20%V to 80%V; C_L =15pF
		$2+0.57 * C_L$	$5.5+0.75 * C_L$	$10+1.25 * C_L$	ns	driver = medium; $C_L \leq 200$ pF
		$1.5+0.18 * C_L$	$1.5+0.28 * C_L$	$8+0.4 * C_L$	ns	driver = strong edge = medium; $C_L \leq 200$ pF
		$0.75+0.08 * C_L$	$0.75+0.11 * C_L$	$2.5+0.21 * C_L$	ns	driver = strong edge = sharp ; $C_L \leq 200$ pF
Asymmetry of sending	t_{TX_ASYM} CC	-0.4	-	0.4	ns	C_L ; valid for all data rates excluding clock tolerance
Input frequency	f_{IN} CC	-	-	160	MHz	

Electrical Specification 5 V / 3.3 V switchable Pads
Table 3-12 RFast 3.3V pad (cont'd)

Parameter	Symbol	Values			Unit	Note / Test Condition
		Min.	Typ.	Max.		
Input hysteresis ³⁾	HYS_{CC}	0.055 * $V_{FLEX/FLEX2}$	-	-	V	non of the neighbor pads are used as output; AL
		0.09 * $V_{FLEX/FLEX2}$	-	-	V	non of the neighbor pads are used as output; TTL
		0.055 * $V_{FLEX/FLEX2}$	-	-	V	non of the neighbor pads are used as output;TTL (degraded, used for CIF)
		125	-	-	mV	two of the neighbor pads are used as output with driver=strong and edge=sharp; AL
Pull-up current ⁴⁾	$I_{PUH_{CC}}$	17	-	-	μA	V_{IH} ; AL and TTL (degraded, used for CIF)
		11	-	-	μA	V_{IH} ; TTL
		-	-	80	μA	V_{IL} ; AL and TTL and TTL (degraded, used for CIF)
Pull-down current ⁵⁾	$I_{PDL_{CC}}$	-	-	105	μA	V_{IH} ; AL and TTL (degraded, used for CIF)
		-	-	115	μA	V_{IH} ; TTL
		19	-	-	μA	V_{IL} ; AL and TTL
		15	-	-	μA	V_{IL} ; TTL (degraded, used for CIF)
Input leakage current	$I_{OZ_{CC}}$	-1700	-	1700	nA	$T_J \leq 150^\circ C$; (0.1 * $V_{FLEX/FLEX2}$) < V_{IN} < (0.9 * $V_{FLEX/FLEX2}$)
		-2100	-	2100	nA	$T_J \leq 150^\circ C$; else
		-3000	-	3000	nA	$T_J \leq 170^\circ C$; (0.1 * $V_{FLEX/FLEX2}$) < V_{IN} < (0.9 * $V_{FLEX/FLEX2}$)
		-4000	-	4000	nA	$T_J \leq 170^\circ C$; else
Input high voltage level	$V_{IH_{SR}}$	0.7 * $V_{FLEX/FLEX2}$	-	-	V	AL
		2.0	-	-	V	TTL
		1.4	-	-	V	TTL (degraded, used for CIF)

Electrical Specification 5 V / 3.3 V switchable Pads
Table 3-12 RFast 3.3V pad (cont'd)

Parameter	Symbol	Values			Unit	Note / Test Condition
		Min.	Typ.	Max.		
Input low voltage level	V_{IL} SR	-	-	0.42 * $V_{FLEX/FLEX}$ 2	V	AL
		-	-	0.8	V	TTL
		-	-	0.5	V	TTL (degraded, used for CIF)
Input low threshold variation	V_{ILD} SR	-33	-	33	mV	max. variation of 1ms; V_{FLEX} = constant; AL
Pin capacitance	C_{IO} CC	-	2	3.5	pF	in addition 2.5pF from package to be added
Pad set-up time to get an software update of the configuration active	t_{SET} CC	-	-	100	ns	

1) In the formulas the value of C_L needs to be entered in pF to obtain results in ns.

2) Rise / fall times are defined 10% - 90% of pad supply voltage.

3) Hysteresis is implemented to avoid metastable states and switching due to internal ground bounce. It can't be guaranteed that it suppresses switching due to external system noise.

4) Values for Pull-up resistor is defined via parameter R_{MDU} in table VADC 5V.

5) Values for Pull-down resistor is defined via parameter R_{MDD} in table VADC 5V.

Table 3-13 Class S 5V

Parameter	Symbol	Values			Unit	Note / Test Condition
		Min.	Typ.	Max.		
Input frequency	f_{IN} CC	-	-	160	MHz	
Input hysteresis ¹⁾	HYS CC	0.09 * V_{DDM}	-	-	V	non of the neighbor pads are used as output; AL
		0.075 * V_{DDM}	-	-	V	non of the neighbor pads are used as output; TTL
		75	-	-	mV	two of the neighbor pads are used as output with driver=strong and edge=sharp; AL
Pull-up current ²⁾	I_{PUH} CC	30	-	-	μ A	V_{IH} ; AL or TTL
		-	-	130	μ A	V_{IL} ; AL or TTL
Pull-down current ³⁾	I_{PDL} CC	-	-	130	μ A	V_{IH} ; AL or TTL
		30	-	-	μ A	V_{IL} ; AL
		28	-	-	μ A	V_{IL} ; TTL

Electrical Specification 5 V / 3.3 V switchable Pads
Table 3-13 Class S 5V (cont'd)

Parameter	Symbol	Values			Unit	Note / Test Condition
		Min.	Typ.	Max.		
Input leakage current	$I_{OZ\ CC}$	-150	-	150	nA	$T_J \leq 150^\circ\text{C}$; else
		-300	-	300	nA	$T_J \leq 150^\circ\text{C}$; PDD option available, or AltRef option available and EDSADC channel connected
		-300	-	300	nA	$T_J \leq 170^\circ\text{C}$; else
		-600	-	600	nA	$T_J \leq 170^\circ\text{C}$; PDD option available, or AltRef option available and EDSADC channel connected
Input high voltage level	$V_{IH\ SR}$	$0.7 * V_{DDM}$	-	-	V	AL
		2.0	-	-	V	TTL
Input low voltage level	$V_{IL\ SR}$	-	-	$0.44 * V_{DDM}$	V	AL
		-	-	0.8	V	TTL
Input low threshold variation	$V_{ILD\ SR}$	-50	-	50	mV	max. variation of 1ms; $V_{DDM} = \text{constant}$; AL
Pin capacitance	$C_{IO\ CC}$	-	2	3	pF	in addition 2.5pF from package to be added
Pad set-up time to get an software update of the configuration active	$t_{SET\ CC}$	-	-	100	ns	

- 1) Hysteresis is implemented to avoid metastable states and switching due to internal ground bounce. It can't be guaranteed that it suppresses switching due to external system noise.
- 2) Values for Pull-up resistor is defined via parameter R_{MDU} in table VADC 5V.
- 3) Values for Pull-down resistor is defined via parameter R_{MDD} in table VADC 5V.

Table 3-14 Class S 3.3V

Parameter	Symbol	Values			Unit	Note / Test Condition
		Min.	Typ.	Max.		
Input frequency	$f_{IN\ CC}$	-	-	160	MHz	

Electrical Specification 5 V / 3.3 V switchable Pads
Table 3-14 Class S 3.3V (cont'd)

Parameter	Symbol	Values			Unit	Note / Test Condition
		Min.	Typ.	Max.		
Input hysteresis ¹⁾	HYS_{CC}	0.055 * V_{DDM}	-	-	V	non of the neighbor pads are used as output; AL
		0.09 * V_{DDM}	-	-	V	non of the neighbor pads are used as output; TTL
		0.065 * V_{DDM}	-	-	V	non of the neighbor pads are used as output; TTL (degraded used for CIF)
		125	-	-	mV	two of the neighbor pads are used as output with driver=strong and edge=sharp; AL
Pull-up current ²⁾	$I_{PUH_{CC}}$	17	-	-	μA	V_{IH} ; AL and TTL (degraded, used for CIF)
		11	-	-	μA	V_{IH} ; TTL
		-	-	80	μA	V_{IL}
Pull-down current ³⁾	$I_{PDL_{CC}}$	-	-	105	μA	V_{IH} ; AL and TTL (degraded, used for CIF)
		-	-	115	μA	V_{IH} ; TTL
		19	-	-	μA	V_{IL} ; AL and TTL
		15	-	-	μA	V_{IL} ; TTL (degraded, used for CIF)
Input leakage current	$I_{OZ_{CC}}$	-150	-	150	nA	$T_J \leq 150^\circ C$; else
		-300	-	300	nA	$T_J \leq 150^\circ C$; PDD option available, or AltRef option available and EDSADC channel connected
		-300	-	300	nA	$T_J \leq 170^\circ C$; else
		-600	-	600	nA	$T_J \leq 170^\circ C$; PDD option available
Input high voltage level	$V_{IH_{SR}}$	0.7 * V_{DDM}	-	-	V	AL
		2.0	-	-	V	TTL
		1.4	-	-	V	TTL (degraded, used for CIF)

Electrical Specification 5 V / 3.3 V switchable Pads
Table 3-14 Class S 3.3V (cont'd)

Parameter	Symbol	Values			Unit	Note / Test Condition
		Min.	Typ.	Max.		
Input low voltage level	V_{IL} SR	-	-	0.42 * V_{DDM}	V	AL
		-	-	0.8	V	TTL
		-	-	0.5	V	TTL (degraded, used for CIF)
Input low threshold variation	V_{ILD} SR	-33	-	33	mV	max. variation of 1ms; V_{DDM} = constant; AL
Pin capacitance	C_{IO} CC	-	2	3	pF	in addition 2.5pF from package to be added
Pad set-up time to get an software update of the configuration active	t_{SET} CC	-	-	100	ns	

- 1) Hysteresis is implemented to avoid metastable states and switching due to internal ground bounce. It can't be guaranteed that it suppresses switching due to external system noise.
- 2) Values for Pull-up resistor is defined via parameter R_{MDU} in table VADC 5V.
- 3) Values for Pull-down resistor is defined via parameter R_{MDD} in table VADC 5V.

Table 3-15 Class D

Parameter	Symbol	Values			Unit	Note / Test Condition
		Min.	Typ.	Max.		
Input leakage current	I_{OZ} CC	-150	-	150	nA	$T_J \leq 150^\circ\text{C}$; else
		-300 ¹⁾	-	300 ¹⁾	nA	$T_J \leq 150^\circ\text{C}$; PDD option available, or AltRef option available and EDSADC channel connected
		-300	-	300	nA	$T_J \leq 170^\circ\text{C}$; else
		-600 ²⁾	-	600 ²⁾	nA	$T_J \leq 170^\circ\text{C}$; PDD option available, or AltRef option available and EDSADC channel connected
Pin capacitance	C_{IO} CC	-	2	3	pF	in addition 2.5pF from package to be added

- 1) For AN11 100 nA need to be added.
- 2) For AN11 200 nA need to be added.

Table 3-16 ADC Reference Pads

Parameter	Symbol	Values			Unit	Note / Test Condition
		Min.	Typ.	Max.		
Input leakage current for V_{AREF}	$I_{OZ2\ CC}$	-1	-	1	μA	$T_J \leq 150^\circ\text{C}$; $V_{AREF} < V_{DDM}$; used for EVADC
		-2	-	2	μA	$T_J \leq 170^\circ\text{C}$; $V_{AREF} < V_{DDM}$; used for EVADC
		-3.5	-	3.5	μA	$T_J \leq 150^\circ\text{C}$; $V_{AREF} \leq V_{DDM} + 50\text{mV}$; used for EVADC
		-7	-	7	μA	$T_J \leq 170^\circ\text{C}$; $V_{AREF} \leq V_{DDM} + 50\text{mV}$; used for EVADC
		-2 ¹⁾	-	2 ¹⁾	μA	$T_J \leq 150^\circ\text{C}$; $V_{AREF} < V_{DDM}$; for EDSADC
		-4 ¹⁾	-	4 ¹⁾	μA	$T_J \leq 170^\circ\text{C}$; $V_{AREF} < V_{DDM}$; for EDSADC
		-6 ¹⁾	-	6 ¹⁾	μA	$T_J \leq 150^\circ\text{C}$; $V_{AREF} \leq V_{DDM} + 50\text{mV}$; for EDSADC
		-12 ¹⁾	-	12 ¹⁾	μA	$T_J \leq 170^\circ\text{C}$; $V_{AREF} \leq V_{DDM} + 50\text{mV}$; for EDSADC

1) Limit is valid for VAREF1 pin.

Table 3-17 Driver Mode Selection for Slow Pads

PDx.2	PDx.1	PDx.0	Port Functionality	Driver Setting
X	X	0	Speed grade 1	medium sharp edge (sm)
X	X	1	Speed grade 2	medium medium edge (m)

Table 3-18 Driver Mode Selection for Fast Pads

PDx.2	PDx.1	PDx.0	Port Functionality	Driver Setting
X	0	0	Speed grade 1	Strong sharp edge (ss)
X	0	1	Speed grade 2	Strong medium edge (sm)
X	1	0	Speed grade 3	medium (m)
X	1	1	Speed grade 4	Reserved, do not use this combination

Table 3-19 Driver Mode Selection for RFast Pads

PDx.2	PDx.1	PDx.0	Port Functionality	Driver Setting
X	0	0	Speed grade 1	Strong sharp edge (ss)
X	0	1	Speed grade 2	Strong medium edge (sm)

Table 3-19 Driver Mode Selection for RFast Pads (cont'd)

PDx.2	PDx.1	PDx.0	Port Functionality	Driver Setting
X	1	0	Speed grade 3	medium (m)
X	1	1	Speed grade 4	RGMI function active

3.6 High performance LVDS Pads

This LVDS pad type is used for the high speed chip to chip communication interface of the new TC37xEXT. It compose out of a LVDSH pad and a fast pad.

$C_L = 2.5$ pF for all LVDSH parameters.

Table 3-20 LVDS - IEEE standard LVDS general purpose link (GPL)

Parameter	Symbol	Values			Unit	Note / Test Condition
		Min.	Typ.	Max.		
Output impedance	R_O CC	40	-	140	Ohm	$V_{cm} = 1.0$ V and 1.4 V
Rise time (20% - 80%)	t_{rise20} CC	-	-	0.75 ¹⁾	ns	$Z_L = 100$ Ohm $\pm 20\%$ @2pF external load
Fall time (20% - 80%)	t_{fall20} CC	-	-	0.75 ²⁾	ns	$Z_L = 100$ Ohm $\pm 20\%$ @2pF external load
Output differential voltage ³⁾	V_{OD} CC	240	-	330	mV	$R_T = 100$ Ohm $\pm 1\%$; LPCR _x .VDIFFADJ=00
		280	-	370	mV	$R_T = 100$ Ohm $\pm 1\%$; LPCR _x .VDIFFADJ=01
		320	-	410	mV	$R_T = 100$ Ohm $\pm 1\%$; LPCR _x .VDIFFADJ=10
		380	-	500	mV	$R_T = 100$ Ohm $\pm 1\%$; LPCR _x .VDIFFADJ=11 ; Multi slave operation
Output voltage high	V_{OH} CC	-	-	1475	mV	$R_T = 100$ Ohm $\pm 1\%$ VDIFFADJ=00 and 01
		-	-	1500	mV	$R_T = 100$ Ohm $\pm 1\%$ VDIFFADJ=10 and 11
Output voltage low	V_{OL} CC	925	-	-	mV	$R_T = 100$ Ohm $\pm 1\%$ VDIFFADJ=00 and 01
		900	-	-	mV	$R_T = 100$ Ohm $\pm 1\%$ VDIFFADJ=10 and 11
Output offset (Common mode) voltage	V_{OS} CC	1125	-	1275	mV	$R_T = 100$ Ohm $\pm 1\%$
Input voltage range	V_I SR	0	-	1600	mV	Driver ground potential difference < 925 mV; $R_T = 100$ Ohm $\pm 10\%$
		0	-	2400	mV	Driver ground potential difference < 925 mV; $R_T = 100$ Ohm $\pm 20\%$
Input differential threshold	V_{idth} SR	-100	-	100	mV	Driver ground potential difference < 900 mV; VDIFFADJ=10 and 11
		-100	-	100	mV	Driver ground potential difference < 925 mV; VDIFFADJ=00 and 01

Electrical Specification High performance LVDS Pads
Table 3-20 LVDS - IEEE standard LVDS general purpose link (GPL) (cont'd)

Parameter	Symbol	Values			Unit	Note / Test Condition
		Min.	Typ.	Max.		
Receiver differential input impedance	R_{in} CC	80	-	120	Ohm	$V_I \leq 2400$ mV
Output differential voltage Sleep Mode ⁴⁾	V_{ODSM} CC	-5	-	20	mV	$R_T = 100$ Ohm $\pm 20\%$; LPCRx.VDIFFADJ=xx
Delta output impedance	$dR0$ SR	-	-	10	%	$V_{cm} = 1.0$ V and 1.4 V
Change in VOS between 0 and 1	$dVOS$ CC	-	-	25	mV	$R_T = 100$ Ohm $\pm 1\%$
Change in Vod between 0 and 1	$dVod$ CC	-	-	25	mV	$R_T = 100$ Ohm $\pm 1\%$
Pad set-up time	t_{SET_LVDS} CC	-	10	13	μ s	
Duty cycle	t_{duty} CC	45	-	55	%	

1) $t_{rise20} = 0.75ns + (C_L - 2)[pF]*20ps$. C_L defines the external load.

2) $t_{fall20} = 0.75ns + (C_L - 2)[pF]*20ps$. C_L defines the external load.

3) Potential violations of the IEEE Std 1596.3 are intended for the new multislave support feature. To be compliant to IEEE Std 1596.3 LPCRx.VDIFFADJ has to be configure to 01.

4) Common Mode voltage of Tx is maintained.

Note: Driver ground potential difference is defined as driver-receiver potential difference, that can result in a voltage shift when comparing driver output voltage level and receiver input voltage level of a transmitted signal.

*Note: R_T in table 'LVDS - IEEE standard LVDS general purpose Link (GPL)' is as termination resistor of the receiver according to figure 3-5 in IEEE Std 1596.3-1996 and is represent in **Figure 3-1** either by R_{IN} or by $R_T=100Ohm$ but not both.*

default after start-up = CMOS function

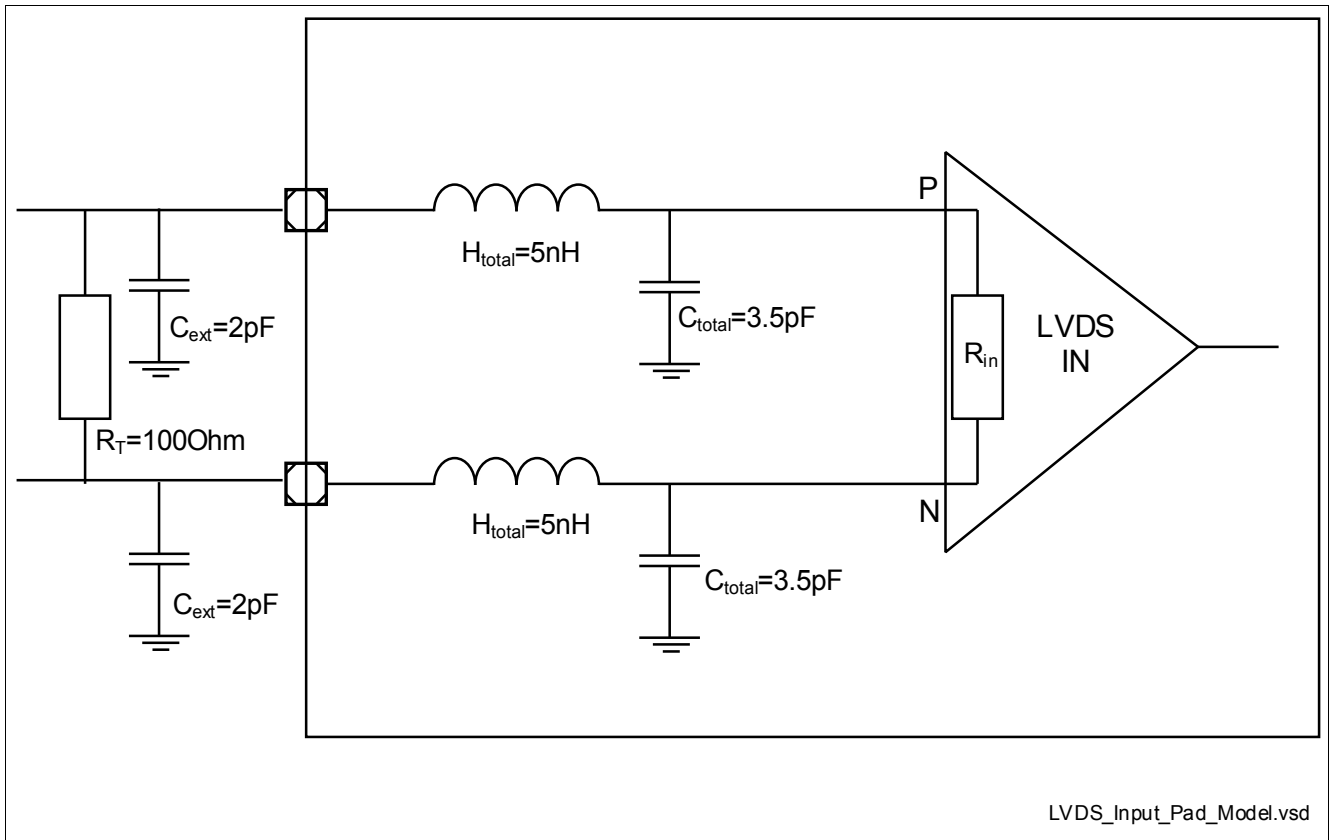

Figure 3-1 LVDS pad Input model

3.7 VADC Parameters

The accuracy of the converter results depends on the reference voltage range. The parameters in the table below are valid for a reference voltage range of $(V_{AREF} - V_{AGND}) \geq 4.5 \text{ V}$. If the reference voltage range is below 4.5 V by a factor of k (e.g. 3.3 V), the accuracy parameters increase by a factor of 1.1/k (e.g. $1.1 \times 4.5 / 3.3 = 1.5$).

Noise on the voltage supply influences the conversion. The accuracy parameters are defined for a supply voltage ripple of below 20 mVpp up to 10 MHz (below 5 mVpp above 10 MHz).

Digital functions overlapping analog inputs influence accuracy.

The total unadjusted error (TUE) is defined without noise. The overall deviation depends on TUE and EN_{RMS} (depending on the noise distribution). Example: For a noise distribution of 4 sigma and $EN_{RMS} = 1.0$ the additional peak-peak noise error is 8 LSB.

Fast compare operations are executed with 10-bit values.

The noise reduction feature improves the result by adding additional conversion steps. The conversion times, therefore, increase accordingly ($4 \times t_{ADCI} + 3 \times t_{ADC}$ for each of 1, 3, or 7 steps).

Table 3-21 VADC 5V

Parameter	Symbol	Values			Unit	Note / Test Condition
		Min.	Typ.	Max.		
EVADC IVR output voltage	$V_{DDK \text{ CC}}$	1.15	-	1.35	V	Measured at low temperature.
Deviation of IVR output voltage V_{DDK}	$dV_{DDK \text{ CC}}$	-2	-	2	%	Based on device-specific value
Analog reference voltage ¹⁾	$V_{AREF \text{ SR}}$	4.5	5.0	$V_{DDM} + 0.05$	V	$4.5 \text{ V} \leq V_{DDM} \leq 5.5 \text{ V}$
		2.97	3.3	$V_{DDM} + 0.05$	V	$2.97 \text{ V} \leq V_{DDM} < 4.5 \text{ V}$
Analog reference ground	$V_{AGND \text{ SR}}$	V_{SSM}	V_{SSM}	V_{SSM}	V	V_{SSM} and V_{AGND} are connected together
Analog input voltage range	$V_{AIN \text{ SR}}$	V_{AGND}	-	V_{AREF}	V	V_{AIN} is limited by the respective pad supply voltage; see pin configuration (buffer type)
Converter reference clock	$f_{ADCI \text{ SR}}$	16	40	53.33	MHz	$4.5 \text{ V} \leq V_{DDM} \leq 5.5 \text{ V}$
		16	20	26.67	MHz	$2.97 \text{ V} \leq V_{DDM} < 4.5 \text{ V}$
Total Unadjusted Error ^{2) 3)}	$TUE \text{ CC}$	-4	-	4	LSB	12-bit resolution for primary/secondary groups, 10-bit resolution for fast compare channels
INL Error ²⁾	$EA_{INL \text{ CC}}$	-3	-	3	LSB	
DNL error ²⁾⁴⁾	$EA_{DNL \text{ CC}}$	-1	-	3	LSB	
Gain Error ²⁾	$EA_{GAIN \text{ CC}}$	-3.5	-	3.5	LSB	
Offset Error ²⁾³⁾	$EA_{OFF \text{ CC}}$	-4	-	4	LSB	
RMS Noise ^{2)5) 6)}	$EN_{RMS \text{ CC}}$	-	0.5	0.8	LSB	Noise reduction level 3
		-	0.5	1.0	LSB	Standard conversion

Electrical Specification VADC Parameters
Table 3-21 VADC 5V (cont'd)

Parameter	Symbol	Values			Unit	Note / Test Condition
		Min.	Typ.	Max.		
Reference input charge consumption per conversion (from V_{AREF}) ^{7) 8) 9)}	Q_{CONV} CC	-	-	20	pC	$V_{AIN} = 0$ V (worst case), precharging disabled
		-	-	10	pC	$V_{AIN} = 0$ V (worst case), precharging enabled, $V_{DDM} - 5\% < V_{AREF} < V_{DDM} + 50$ mV
Switched capacitance of an analog input	C_{AINS} CC	-	2.5	3.4	pF	Input buffer disabled
Analog input charge consumption ¹⁰⁾	Q_{AINS} CC	-	-	3.5	pC	Primary groups and fast compare channels; $V_{AIN} = V_{AREF}$; $V_{DDM} = 5.0$ V; input buffer enabled; $T_J \leq 150^\circ\text{C}$
		-	-	3.8	pC	Primary groups and fast compare channels; $V_{AIN} = V_{AREF}$; $V_{DDM} = 5.0$ V; input buffer enabled; $T_J > 150^\circ\text{C}$
		-	-	4.4	pC	Secondary groups; $V_{AIN} = V_{AREF}$; $V_{DDM} = 5.0$ V; input buffer enabled; $T_J \leq 150^\circ\text{C}$
		-	-	4.8	pC	Secondary groups; $V_{AIN} = V_{AREF}$; $V_{DDM} = 5.0$ V; input buffer enabled; $T_J > 150^\circ\text{C}$

Electrical Specification VADC Parameters
Table 3-21 VADC 5V (cont'd)

Parameter	Symbol	Values			Unit	Note / Test Condition
		Min.	Typ.	Max.		
Sampling time	t_s SR	100	-	-	ns	Primary group or fast compare channel, 4.5 V $\leq V_{DDM} \leq 5.5$ V; input buffer disabled
		300	-	-	ns	Primary group or fast compare channel, 4.5 V $\leq V_{DDM} \leq 5.5$ V; input buffer enabled
		500	-	-	ns	Secondary group, 4.5 V $\leq V_{DDM} \leq 5.5$ V; input buffer disabled
		700	-	-	ns	Secondary group, 4.5 V $\leq V_{DDM} \leq 5.5$ V; input buffer enabled
		200	-	-	ns	Primary Group or fast compare channel, 2.97 V $\leq V_{DDM} < 4.5$ V; input buffer disabled
		400	-	-	ns	Primary group or fast compare channel, 2.97 V $\leq V_{DDM} < 4.5$ V; input buffer enabled
		1000	-	-	ns	Secondary group, 2.97 V $\leq V_{DDM} < 4.5$ V; input buffer disabled
		1200	-	-	ns	Secondary group, 2.97 V $\leq V_{DDM} < 4.5$ V; input buffer enabled
Sampling time for calibration	t_{SCAL} SR	50	-	-	ns	4.5 V $\leq V_{DDM} \leq 5.5$ V
		100	-	-	ns	2.97 V $\leq V_{DDM} < 4.5$ V
Input buffer switch-on time	t_{BUF} CC	-	0.4	1	μ s	
Wakeup time	t_{WU} CC	-	0.1	0.2	μ s	Fast standby mode
		-	1.6	3	μ s	Slow standby mode
Broken wire detection delay against V_{AREF}	t_{BWR} CC	-	100	-	cycles	Result above 80% of full scale range, analog input buffer disabled
Broken wire detection delay against V_{AGND}	t_{BWG} CC	-	100	-	cycles	Result below 10% of full scale range, analog input buffer disabled
Converter diagnostics unit resistance ¹¹⁾	R_{CSD} CC	45	-	75	kOhm	
Converter diagnostics voltage accuracy	dV_{CSD} CC	-10	-	10	%	Percentage refers to V_{DDM}

Electrical Specification VADC Parameters

Table 3-21 VADC 5V (cont'd)

Parameter	Symbol	Values			Unit	Note / Test Condition
		Min.	Typ.	Max.		
Resistance of the multiplexer diagnostics pull-up device	$R_{MDU} CC$	30	-	42	kOhm	$0 V \leq V_{IN} \leq 0.9 * V_{DDM}$, Automotive Levels
		56	-	78	kOhm	$0 V \leq V_{IN} \leq 0.9 * V_{DDM}$, TTL Levels
Resistance of the multiplexer diagnostics pull-down device	$R_{MDD} CC$	43	-	58	kOhm	$0.1 * V_{DDM} \leq V_{IN} \leq V_{DDM}$, Automotive level
		18	-	25	kOhm	$0.1 * V_{DDM} \leq V_{IN} \leq V_{DDM}$, TTL level
Resistance of the pull-down test device	$R_{PDD} CC$	-	-	0.3	kOhm	Measured at pad input voltage $V_{IN} = V_{DDM} / 2$.

- 1) These limits apply to the standard reference input as well as to the alternate reference input.
- 2) Parameter depends on reference voltage range and supply ripple, see introduction. Resulting worst case combined error is arithmetic combination of TUE and EN_{RMS} . Tests are done with postcalibration disabled, after completing the startup calibration.
- 3) Digital functions on analog inputs influence accuracy. The values for this parameter increase by 3 LSB₁₂.
- 4) Monotonic characteristic, no missing codes when calibrated.
- 5) Parameter EN_{RMS} refers to a 1 sigma distribution.
- 6) For analog inputs with overlaid digital GPIOs the RMS noise (EN_{RMS}) can be up to 2 LSB₁₂ (soft switching for DC/DC enabled).
- 7) For reduced reference voltages the consumed charge is reduced by factor k.
- 8) Maximum charge increases by 15 pC when BWD (Broken Wire Detection) is active.
- 9) Fast compare channels only consume 1/3 of the charge for a primary/secondary group.
- 10) For analog inputs with overlaid digital GPIOs or with PDD function this value increases by 1 pC.
- 11) Use a sample time of at least 1.1 μs to enable proper settling of the test voltage.

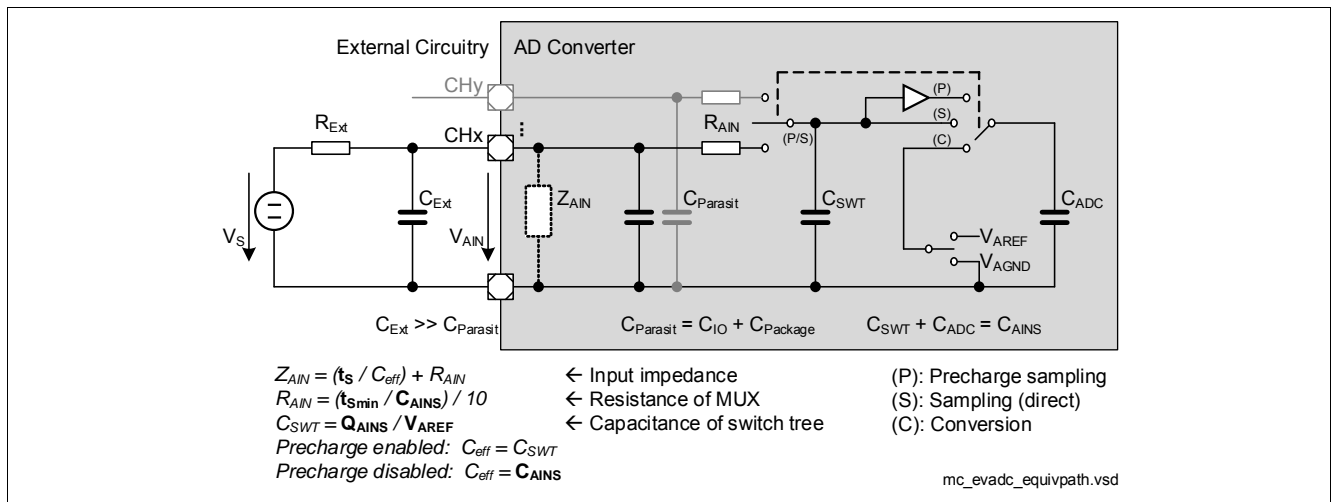

Figure 3-2 Equivalent Circuitry for Analog Inputs

3.8 DSADC Parameters

The DSADC parameters are valid only for voltage range $4.5\text{ V} \leq V_{DDM} \leq 5.5\text{ V}$.

These parameters describe the product properties and do not include external circuitry. The values are valid for junction temperatures $T_J \leq 150^\circ\text{C}$ if not defined explicitly.

Calibration is specified for gain factors 1 and 2, calibrated values refer to these settings.

The signal-noise ratio (SNR) is specified for differential inputs. For single ended operation the resulting signal-noise ratio is reduced by 6 dB. For quasi-differential mode (i.e. using V_{CM}) its reduced by 3dB with gain=2 (6dB with gain=1).

Table 3-22 DSADC 5V

Parameter	Symbol	Values			Unit	Note / Test Condition
		Min.	Typ.	Max.		
Common mode voltage bias resistance	R_{BIAS} CC	105	130	155	kOhm	On-chip variation $\leq \pm 2.5\%$.
Positive reference voltage	V_{AREF} SR	4.5	-	$V_{DDM} + 0.05$	V	
Reference ground voltage	V_{AGND} SR	V_{SSM}	-	V_{SSM}	V	V_{SSM} and V_{AGND} are connected together
Reference load current	I_{REF} CC	-	10	12	μA	Per modulator
		-	-	14	μA	Per modulator, $T_J > 150^\circ\text{C}$
Common mode voltage accuracy ¹⁾	dV_{CM} CC	-100	-	100	mV	Deviation from selected voltage
Analog input voltage range	V_{DSIN} SR	V_{SSM}	-	$2 * V_{DDM}$	V	Differential; $V_{DSxP} - V_{DSxN}$
		V_{SSM}	-	V_{DDM}	V	Single ended
Input current ²⁾	I_{RMS} CC	7	10	15	μA	Exact value ($\pm 1\%$) available in UCB; valid for gain = 1 and $f_{MOD} = 26.7\text{ MHz}$
On-chip modulator clock frequency	f_{MOD} SR	16	-	40	MHz	
Gain error ^{3) 4)}	ED_{GAIN} CC	-0.2 ⁵⁾	± 0.1 ⁵⁾	0.2 ⁵⁾	%	$T_J \leq 150^\circ\text{C}$; Target, calibrated, V_{AREF} constant after calibration; $f_{MOD} = 26.67\text{ MHz}$
		-	± 0.25	-	%	$T_J > 150^\circ\text{C}$; V_{AREF} constant after calibration; $f_{MOD} = 26.67\text{ MHz}$
		-1	-	1	%	Calibrated once; $f_{MOD} = 26.67\text{ MHz}$
		-2.5	-	2.5	%	Uncalibrated; $f_{MOD} = 26.67\text{ MHz}$

Electrical Specification DSADC Parameters
Table 3-22 DSADC 5V (cont'd)

Parameter	Symbol	Values			Unit	Note / Test Condition
		Min.	Typ.	Max.		
DC offset error ³⁾	ED_{OFF} CC	-5 ⁵⁾	-	5 ⁵⁾	mV	Calibrated; $f_{MOD} = 26.67$ MHz
		-10	-	10	mV	Calibrated once; $f_{MOD} = 26.67$ MHz
		-30	-	30	mV	Uncalibrated; $f_{MOD} = 26.67$ MHz
Signal-Noise Ratio for differential input signals ^{2),6) 7)}	SNR CC	80	-	-	dB	$T_J \leq 150^\circ\text{C}$; $f_{PB} = 30$ kHz; $f_{MOD} = 26.67$ MHz
		78	-	-	dB	$T_J \leq 150^\circ\text{C}$; $f_{PB} = 50$ kHz; $f_{MOD} = 26.67$ MHz
		74	-	-	dB	$T_J \leq 150^\circ\text{C}$; $f_{PB} = 100$ kHz; $f_{MOD} = 26.67$ MHz
Signal-Noise Ratio degradation	DSNR CC	-	-	3	dB	$T_J > 150^\circ\text{C}$; Resulting Signal-Noise Ratio value is SNR - DSNR
Spurious-free dynamic range ³⁾	SFDR CC	60	-	-	dB	$f_{MOD} = 26.67$ MHz
Output sampling rate	f_D CC	3.906	-	300	kHz	16 MHz / 4096, without integrator
Pass band	f_{PB} CC	1.302	-	100	kHz	Output data rate: $f_D = f_{PB} * 3$; without integrator
		1.302	-	10	kHz	Output data rate: $f_D = f_{PB} * 6$; without integrator
Pass band ripple	df_{PB} CC	-0.08	-	0.08	dB	FIR filters enabled
Stop band attenuation	SBA CC	40	-	-	dB	$0.5 f_D \dots 1.0 f_D$
		45	-	-	dB	$1.0 f_D \dots 1.5 f_D$
		50	-	-	dB	$1.5 f_D \dots 2.0 f_D$
		55	-	-	dB	$2.0 f_D \dots 2.5 f_D$
		60	-	-	dB	$2.5 f_D \dots \text{OSR}/2 f_D$
DC compensation factor	DCF CC	-3	-	-	dB	$10^{-5} f_D$, offset compensation filter enabled (FCFGMx.OCEN = 001 _B)
Modulator settling time	t_{MSET} CC	-	-	20	μs	After switching on, voltage regulator already running

1) On pins with overlaid GPIO function the max. limit increases by up to 25 mV due to leakage current for $T_J > 150^\circ\text{C}$.

2) For detailed information, refer to the User Manual chapter.

3) This parameter is valid within the defined range of f_{MOD} .

4) Gain mismatch error between the different EDSADC channels is within $\pm 0.5\%$.

Electrical Specification DSADC Parameters

- 5) Recalibration needed in case of a temperature change $>20^{\circ}\text{C}$
- 6) These values are valid for an analog gain factor of 1. Subtract 3 dB for each higher gain factor.
- 7) For single ended input signals and gain1, the SNR is reduced by 6 dB.

3.9 MHz Oscillator

OSC_XTAL is used as accurate and exact clock source. OSC_XTAL supports 16 MHz to 40 MHz crystals external outside of the device. Support of ceramic resonators is also provided.

Table 3-23 OSC_XTAL

Parameter	Symbol	Values			Unit	Note / Test Condition
		Min.	Typ.	Max.		
Input current at XTAL1	I_{IX1} CC	-70	-	70	μA	$V_{IN} > 0\text{V}$; $V_{IN} < V_{EXT}$
Oscillator frequency	f_{OSC} SR	4	-	40	MHz	Direct Input Mode selected, if shaper is not bypassed
		16	-	40	MHz	External Crystal Mode selected
Oscillator start-up time	t_{OSCS} CC	-	-	3 ¹⁾	ms	$20\text{MHz} \leq f_{OSC}$ and 8pF load capacitance
Input voltage at XTAL1 ²⁾	V_{IX} SR	-0.7	-	$V_{EXT} + 0.5$	V	If shaper is not bypassed
Input amplitude (peak to peak) at XTAL1	V_{PPX} SR	$0.3 * V_{EXT}$	-	$V_{EXT} + 1.0$	V	If shaper is not bypassed; $f_{OSC} > 25\text{MHz}$
		$0.35 * V_{EXT}$	-	$V_{EXT} + 1.0$	V	If shaper is not bypassed; $f_{OSC} \leq 25\text{MHz}$
Internal load capacitor	C_{L0} CC	1.30	1.40	1.55	pF	enabled via bit OSCCON.CAP0EN
Internal load capacitor	C_{L1} CC	3.05	3.35	3.70	pF	enabled via bit OSCCON.CAP1EN
Internal load capacitor	C_{L2} CC	7.85	8.70	9.55	pF	enabled via bit OSCCON.CAP2EN
Internal load capacitor	C_{L3} CC	12.05	13.35	14.65	pF	enabled via bit OSCCON.CAP3EN
Internal load stray capacitor between XTAL1 and XTAL2	C_{XINTS} CC	1.15	1.20	1.25	pF	
Internal load stray capacitor between XTAL1 and ground	C_{XTAL1} CC	-	2.5	4	pF	
Duty cycle at XTAL1 ³⁾	DC_{X1} SR	35	-	65	%	$V_{XTAL1} = 0.5 * V_{PPX}$
Absolute RMS jitter at XTAL1 ³⁾	J_{ABSX1} SR	-	-	28	ps	10 KHz to $f_{OSC}/2$
Slew rate at XTAL1 ³⁾	SR_{XTAL1} SR	0.3	-	-	V/ns	Maximum 30% difference between rising and falling slew rate

1) t_{OSCS} is defined from the moment when the Oscillator Mode is set to External Crystal Mode until the oscillations reach an amplitude at XTAL1 of $0.3 * V_{EXT}$.

This value depends on the frequency of the used external crystal. For faster crystal frequencies this value decrease.

2) For supply ($V_{EXT} < 5.3\text{V}$ V_{IX}) min could be down to -0.9V. For XTAL1 an input level down to -0.9V will not cause and damage or reliability problem operating with an external crystal.

3) Square wave input signal for XTAL1.

Note: It is strongly recommended to measure the oscillation allowance (negative resistance) in the final target system (layout) to determine the optimal parameters for the oscillator operation. Please refer to the limits specified by the crystal or ceramic resonator supplier.

3.10 Back-up Clock

The back-up clock provides an alternative clock source.

Table 3-24 Back-up Clock

Parameter	Symbol	Values			Unit	Note / Test Condition
		Min.	Typ.	Max.		
Back-up clock accuracy before trimming	f_{BACKUT} CC	70	100	130	MHz	$V_{\text{EXT}} \geq 2.97\text{V}$
Back-up clock accuracy after trimming ¹⁾	f_{BACKT} CC	98	100	102	MHz	$V_{\text{EXT}} \geq 2.97\text{V}$
Standby clock	f_{SB} CC	25	70	110	kHz	$V_{\text{EXT}} \geq 2.97\text{V}$

1) A short term trimming providing the accuracy required by LIN communication is possible by periodic trimming every 2 ms for temperature and voltage drifts up to temperatures of 125 celcius

3.11 Temperature Sensor
Table 3-25 DTS PMS

Parameter	Symbol	Values			Unit	Note / Test Condition
		Min.	Typ.	Max.		
Measurement time for each conversion ¹⁾	t_M CC	-	-	2.7	ms	Measured from cold power-on reset release
Calibration reference accuracy	T_{CALACC} CC	-1	-	1	°C	calibration points @ $T_J=-40^{\circ}\text{C}$ and $T_J=127^{\circ}\text{C}$
Accuracy over temperature range	T_{NL} CC	-2	-	2	°C	T_{CALACC} has to be added in addition
DTS temperature range	T_{SR} SR	-40	-	170	°C	

1) After warm reset t_M is not restarted and is measured from last conversion.

Table 3-26 DTS Core

Parameter	Symbol	Values			Unit	Note / Test Condition
		Min.	Typ.	Max.		
Measurement time for each conversion ¹⁾	t_M CC	-	-	2.7	ms	Measured from cold power-on reset release
Temperature difference between on chip temperature sensors	ΔT CC	-3	-	3	°C	
Calibration reference accuracy	T_{CALACC} CC	-2	-	2	°C	calibration points @ $T_J=-40^{\circ}\text{C}$ and $T_J=127^{\circ}\text{C}$
Accuracy over temperature range	T_{NL} CC	-2	-	2	°C	T_{CALACC} has to be added in addition
DTS temperature range	T_{SR} SR	-40	-	170	°C	

1) After warm reset t_M is not restarted and is measured from last conversion.

3.12 Power Supply Current

The total power supply current defined below consists of leakage and switching component.

Application relevant values are typically lower than those given in the following table and depend on the customer's system operating conditions (e.g. thermal connection or used application configurations).

The operating conditions for the parameters in the following table are:

The real (realistic) power pattern defines the following conditions:

- $T_J = 150\text{ °C}$
- $f_{SRI} = f_{CPUx} = 300\text{ MHz}$
- $f_{GTM} = 200\text{ MHz}$
- $f_{SPB} = f_{STM} = f_{BAUD1} = f_{BAUD2} = f_{ASCLINx} = 100\text{ MHz}$
- $V_{DD} = 1.275\text{ V}$
- $V_{DDP3} / \text{FLEX} = 3.366\text{ V}$
- $V_{EXT / EVRSB / M} = V_{DDM} = 5.1\text{ V}$
- all cores are active including two lockstep core (IPC=0.6)
- the following peripherals are inactive: HSM, HSCT, GETH, Ethernet, PSI5, I2C, FCE, CIF, and MTU

The max power pattern defines the following conditions:

- $T_J = 150\text{ °C}$
- $f_{SRI} = f_{CPUx} = 300\text{ MHz}$
- $f_{GTM} = 200\text{ MHz}$
- $f_{SPB} = f_{STM} = f_{BAUD1} = f_{BAUD2} = f_{ASCLINx} = 100\text{ MHz}$
- $V_{DD} = 1.375\text{ V}$
- $V_{DDP3} / \text{FLEX} = 3.63\text{ V}$
- $V_{EXT / EVRSB / M} = V_{DDM} = 5.5\text{ V}$
- all cores are active including three lockstep cores (IPC=1.2)
- the following modules are inactive: GETH, FCE, CIF, and MTU

Table 3-27 Current Consumption

Parameter	Symbol	Values			Unit	Note / Test Condition
		Min.	Typ.	Max.		
Σ Sum of I_{DD} core and peripheral supply currents (incl. $I_{DDPORST} + \Sigma I_{DDCX0} + \Sigma I_{DDCxx} + I_{DDGTM} + I_{DDSB}$)	$I_{DDRAIL\ CC}$	-	-	960 ¹⁾	mA	max power pattern; valid for Feature Package TE, and TX products
		-	-	775	mA	real power pattern; valid for Feature Package TE, and TX products

Electrical Specification Power Supply Current
Table 3-27 Current Consumption (cont'd)

Parameter	Symbol	Values			Unit	Note / Test Condition
		Min.	Typ.	Max.		
I_{DD} core current during active power-on reset (PORST pin held low). Leakage current of core domain. ²⁾	$I_{DDPORST}$ CC	-	-	190	mA	$V_{DD} = 1.275V$; $T_J = 125^\circ C$; valid for Feature Package TE, and TX products
		-	-	315	mA	$V_{DD} = 1.275V$; $T_J = 150^\circ C$; valid for Feature Package TE, and TX products
		-	-	425	mA	$V_{DD} = 1.275V$; $T_J = 165^\circ C$; valid for Feature Package TE, and TX products
Σ Sum of I_{DDP3} 3.3 V supply currents	$I_{DDP3RAIL}$ CC	-	-	45 ²⁾	mA	max power pattern incl. Flash read current and Dflash programming current.
		-	-	36 ³⁾	mA	real power pattern incl. Flash read current and Dflash programming current.
Σ Sum of external I_{EXT} supply currents (incl. $I_{EXTFLEX} + I_{EVRSB} + I_{EXTLVDS}$)	$I_{EXTRAIL}$ CC	-	-	50	mA	max power pattern
		-	-	35 ⁴⁾	mA	real power pattern
I_{EXT} and I_{FLEX} supply current	$I_{EXTFLEX}$ CC	-	-	11 ^{5) 6)}	mA	real power pattern with port activity absent; PORST output inactive.
I_{EVRSB} supply current ²⁾	I_{EVRSB} CC	-	-	8.5	mA	real power pattern; PMS/EVR module current considered without SCR and Standby RAM during RUN mode.
Σ Sum of external I_{DDM} supply currents (incl. $I_{DDMEVADC} + I_{DDMEDSADC}$)	I_{DDM} CC	-	-	27	mA	real power pattern; sum of currents of EDSADC and EVADC modules
Σ Sum of all currents (incl. $I_{EXTRAIL} + I_{DDMRAIL} + I_{DDx3RAIL} + I_{DD}$)	I_{DDTOT} CC	-	-	873	mA	real power pattern; $T_J = 150^\circ C$; valid for Feature Package TE, and TX products
		-	-	1015	mA	real power pattern; $T_J = 160^\circ C$; valid for Feature Package TE, and TX products

Electrical Specification Power Supply Current
Table 3-27 Current Consumption (cont'd)

Parameter	Symbol	Values			Unit	Note / Test Condition
		Min.	Typ.	Max.		
Σ Sum of all currents with DC-DC EVRC regulator active ⁷⁾	$I_{DDTOTDC3}$ CC	-	-	430	mA	real power pattern; EVRC reset settings with 72% efficiency; $V_{EXT} = 3.3V$; $T_J = 150^\circ C$
Σ Sum of all currents with DC-DC EVRC regulator active ⁷⁾	$I_{DDTOTDC5}$ CC	-	-	320	mA	real power pattern; EVRC reset settings with 72% efficiency; $V_{EXT} = 5V$; $T_J = 150^\circ C$
Σ Sum of all currents (SLEEP mode) ²⁾	I_{SLEEP} CC	-	-	25	mA	All CPUs in idle, All peripherals in sleep, $f_{SRI/SPB} = 1 MHz$ via LPDIV divider; $T_J = 25^\circ C$
Σ Sum of all currents (STANDBY mode) drawn at V_{EVRSB} supply pin ⁸⁾	$I_{STANDBY}$ CC	-	-	130 ⁹⁾	μA	32 kB Standby RAM block active. SCR inactive. Power to remaining domains switched off. $T_J = 25^\circ C$; $V_{EVRSB} = 5V$
Maximum power dissipation	PD SR	-	-	1855	mW	max power pattern; valid for Feature Package TE, and TX products
		-	-	1425	mW	real power pattern; valid for Feature Package TE, and TX products

- 1) In QFP package for TC37xED emulation device, the total (IDDED + IDD) current need to be limited to 700 mA. The maximum (IDDED + IDD) current for TC37xED is supported only in BGA packages.
- 2) Limits are defined for real power pattern ($V_{DD} = 1.275V$). For max power pattern limit has to be multiplied by the factor 1.22.
- 3) Realistic Pflash read pattern with 50% Pflash bandwidth utilization and a code mix of 50% 0s and 50% 1s. A common decoupling capacitor of atleast 100nF for (V_{DDP3}) is used. Continuous Dflash programming in burst mode with 3.3 V supply and realistic Pflash read access in parallel. Erase currents of the corresponding flash modules are less than the respective programming currents at V_{DDP3} pin. Programming and erasing flash may generate transient current spikes of up to x mA for maximum x us which is handled by the decoupling and buffer capacitors. This parameter is relevant for external power supply dimensioning and not for thermal considerations.
- 4) Limits are defined for real power pattern. For ADAS power pattern limit sum up to 42mA.
- 5) The current consumption includes only minimal port activity.
- 6) Limits are defined for real power pattern. For ADAS power pattern limit has to be multiplied by the factor 0.7.
- 7) The total current drawn from external regulator is estimated with 72% EVRC SMPS regulator efficiency. IDDTOTDCx is calculated from IDDTOT using the scaled core current $[(IDD \times VDD)/(V_{in} \times Efficiency)]$ and constitutes all other rail currents and IDDM.
- 8) The same current limits apply also for the other power pattern.
- 9) Σ Sum of all currents during RUN mode at VEVRSB supply pin is less than (IEVRSB + 4 mA Standby RAM current + ISCRSB if SCR active). Σ It is recommended to have atleast 100 nF decoupling capacitor at this pin. 32kB of Standby SRAM contributes less than 10uA to ISTANDBY current.

Electrical Specification Power Supply Current
Table 3-28 Module Current Consumption

Parameter	Symbol	Values			Unit	Note / Test Condition
		Min.	Typ.	Max.		
I_{DDP3} supply current for programming of a Pflash or Dflash bank ¹⁾	$I_{DDP3PROG}$ CC	-	-	25	mA	Pflash 3.3V programming current adder when using external 3.3V supply.
		-	-	9 ²⁾	mA	Pflash 3.3V programming current adder when using external 5V supply.
I_{EXT} supply current added by LVDS pads in LVDS mode ¹⁾	$I_{EXTLVDS}$ CC	-	-	16	mA	real power pattern; 4 pairs of LVDS pins active with transmit function
		-	-	9 ³⁾	mA	real power pattern; 6 pairs of LVDS pins active with receive function
Σ Sum of external I_{DDM} supply currents (incl. $I_{DDMEVADC} + I_{DDMEDSADC}$)	I_{DDM} CC	-	-	14	mA	real power pattern; current for EDSADC modules only and EVADC modules are inactive; 4 EDSADC channels active continuously.
		-	-	22 ⁴⁾	mA	max power pattern; current for EDSADC modules only and EVADC modules are inactive; all EDSADC channels active continuously.
		-	-	13 ⁵⁾	mA	real power pattern; current for EVADC modules only and EDSADC modules are inactive; 8 EVADC modules active.
		-	-	15 ⁶⁾	mA	max power pattern; current for EVADC modules only and EDSADC modules are inactive; all EVADC modules active.
		-	-			

Electrical Specification Power Supply Current
Table 3-28 Module Current Consumption (cont'd)

Parameter	Symbol	Values			Unit	Note / Test Condition
		Min.	Typ.	Max.		
I_{DDP3} supply current for erasing of a Pflash or Dflash bank	$I_{DDP3ERASE}$ CC	-	-	25	mA	Pflash 3.3V erasing current adder when using external 3.3V supply.
SCR 8-bit Standby Controller current incl. PMS in STANDBY Mode drawn at V_{EVRSB} supply pin	I_{SCRSB} CC	-	-	7 ⁷⁾	mA	SCR power pattern incl. PMS current consumption with fback clock active; $f_{SYS_SCR} = 20\text{MHz}$; $T_J = 150^\circ\text{C}$
		-	0.150	-	mA	SCR power pattern incl. PMS current consumption with fback inactive; $f_{SYS_SCR} = 70\text{kHz}$; $T_J = 25^\circ\text{C}$
SCR 8-bit Standby Controller CPU in IDLE mode ⁸⁾	$I_{SCRIDLE}$ CC	-	-	3.5	mA	real power pattern. CPU set into idle mode.

- 1) The same current limits apply also for the other power pattern.
- 2) During Pflash programming at 5V, additional 2 mA is drawn at VEXT supply rail.
- 3) A single LVDS pair with receive function is limited to 1.5mA ($I_{EXTLVDS}$).
- 4) A single DS channel instance consumes 4 mA.
- 5) EVADC current is limited to 3mA in "ADAS power pattern with 2 EVADC" at (I_{DDM}).
- 6) A single VADC unit consumes 1.3 mA.
- 7) If SCR ADCOMP is activated, an additional 0.6 mA adder is to be considered.
- 8) Limits are defined for real power pattern ($V_{DD} = 1.275\text{V}$). For max power pattern limit has to be multiplied by the factor 1.22.

Table 3-29 Module Core Current Consumption

Parameter	Symbol	Values			Unit	Note / Test Condition
		Min.	Typ.	Max.		
I_{DD} core current of CPUx main core with CPUx lockstep core inactive	I_{DDCx0} CC	-	-	72	mA	max power pattern; IPC=1.2
		-	-	48	mA	real power pattern; IPC=0.6
I_{DD} core current of CPUx main core with CPUx lockstep core active	I_{DDCxx} CC	-	-	$I_{DDCx0} + 48$	mA	max power pattern; IPC=1.2
		-	-	$I_{DDCx0} + 37$	mA	real power pattern; IPC=0.6

Electrical Specification Power Supply Current
Table 3-29 Module Core Current Consumption (cont'd)

Parameter	Symbol	Values			Unit	Note / Test Condition
		Min.	Typ.	Max.		
I_{DD} core current added by GTM	I_{DDGTM} CC	-	-	110	mA	max power pattern
		-	-	90	mA	real power pattern; TIMx, TOMx, ATOMx, MCSx active. 2 clusters at 200 MHz.
		-	-	50	mA	TIMx, TOMx active at 100MHz. ATOMx, MCSx, DPLL inactive. 2 clusters at 100 MHz.
I_{DD} core current added by HSM	I_{DDHSM} CC	-	-	20 ¹⁾	mA	max power pattern; HSM running at 100MHz.
I_{DD} core current added by CIF	I_{DDCIF} CC	-	-	48	mA	conditions t.b.d.
I_{DD} core dynamic current added by LBIST	I_{DDLBI} CC	-	-	200 ²⁾	mA	LBIST Configuration A; $1.2V \leq V_{DD}$
I_{DD} core dynamic current added by MBIST	I_{DDMBI} CC	-	-	225	mA	fMBIST = 300MHz; tMBIST < 6ms. MTU Ganging procedure for SRAM test and initialization; VDD = 1.375V.

1) The current consumption includes basic HSM activity incl. AES module.

2) LBIST is executed either during start-up phase or can be triggered by application software. Secondary voltage monitors are inactive during the LBIST execution time (t_{LBIST}). During the start-up phase externally supplied V_{DD} voltage has to be equal or greater than 1.2V (V_{DD} nominal - 4%) for static accuracy. If V_{DD} is supplied internally by EVRC, EVRC takes care not to violate the V_{DD} 1.2V static under voltage limit.

3.12.1 Calculating the 1.25 V Current Consumption

The current consumption of the 1.25 V rail compose out of two parts:

- Static current consumption
- Dynamic current consumption

The static current consumption is related to the device temperature T_J and the dynamic current consumption depends of the configured clocking frequencies and the software application executed. These two parts needs to be added in order to get the rail current consumption.

$$I_0 = 6,5 \left[\frac{\text{mA}}{\text{C}} \right] \times e^{0,02 \times T_J[\text{C}]} \quad (3.1)$$

$$I_0 = 15,6 \left[\frac{\text{mA}}{\text{C}} \right] \times e^{0,02 \times T_J[\text{C}]} \quad (3.2)$$

Equation (3.1) defines the typical static current consumption and **Equation (3.2)** defines the maximum static current consumption. Both functions are valid for $V_{DD} = 1.275 \text{ V}$.

3.13 Power Supply Infrastructure and Supply Start-up

3.13.1 Supply Ramp-up and Ramp-down Behavior

3.13.1.1 Single Supply mode (a)

Electrical Specification Power Supply Infrastructure and Supply Start-up

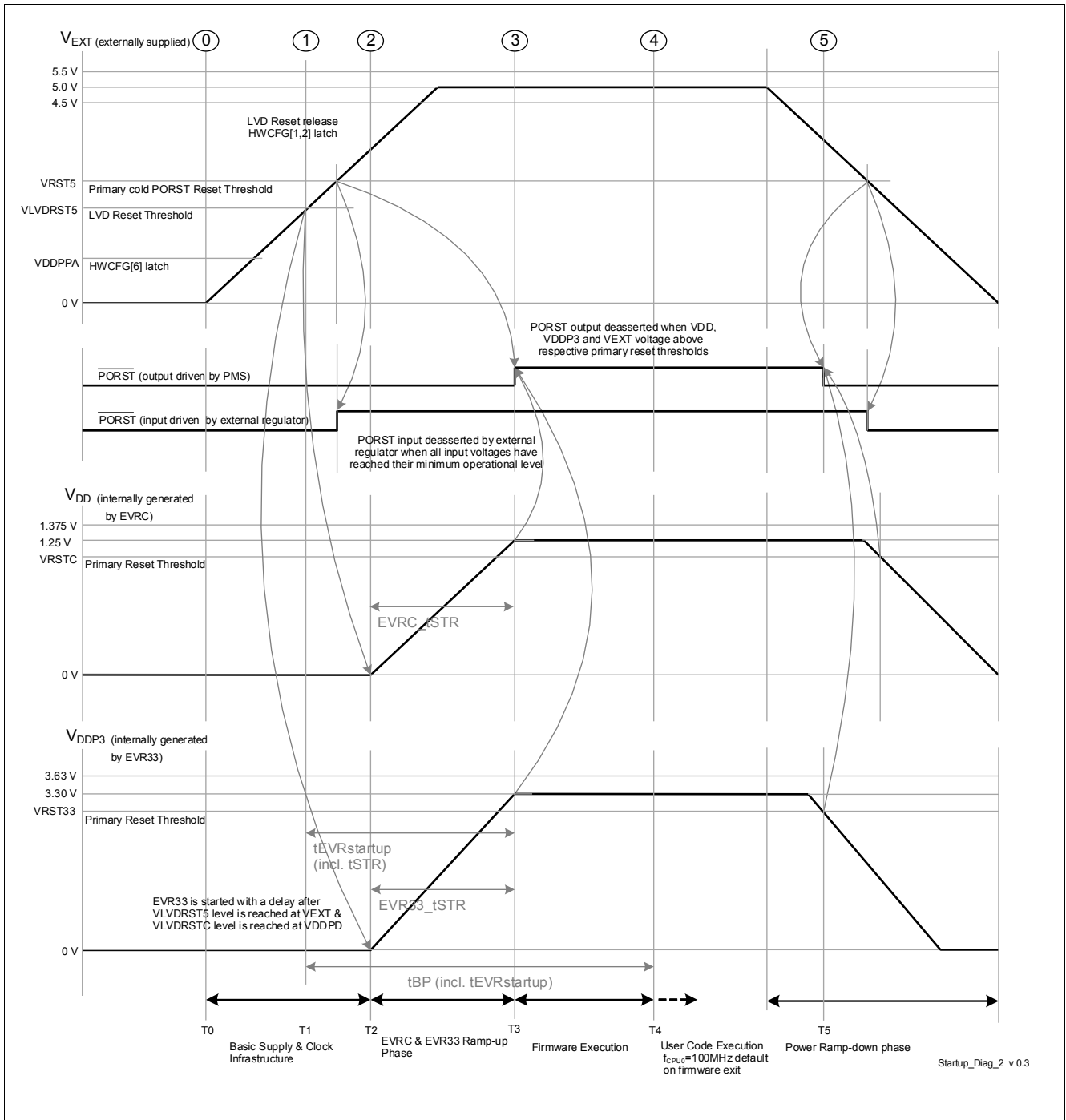

Figure 3-3 Single Supply mode (a) - VEXT (5 V) single supply

VEXT = 5 V single supply mode. VDD and VDDP3 are generated internally by the EVRC and EVR33 internal regulators.

- The rate at which current is drawn from the external regulator (dI_{EXT} / dt) is limited during the basic infrastructure and EVRx regulator start-up phase (T0 up to T2) to a maximum of 100 mA with 100 us settling time. Start-up slew rates for supply rails shall comply to datasheet parameter SR. The slope is defined as the maximal tangential slope between 0% to 100% voltage level. Actual waveform may not represent the specification.

Electrical Specification Power Supply Infrastructure and Supply Start-up

- Furthermore it is also ensured that the current drawn from the regulator (dI_{DD}/dt) is limited during the Firmware start-up phase (T3 up to T4) to a maximum of 100 mA with 100 us settling time.
- PORST is active/asserted when either PORST (input) or PORST (output) is active/asserted.
- PORST (input) active means that the reset is held active by external agents by pulling the PORST pin low. It is recommended to keep the PORST (input) asserted until the external supply is above the respective primary reset threshold.
- PORST (output) active means that μC asserts the reset internally and drives the PORST pin low thus propagating the reset to external devices. The PORST (output) is asserted by the μC when at least one among the three supply domains (VDD, VDDP3 or VEXT) violate their primary under-voltage reset thresholds. The PORST (output) is de-asserted by the μC when all supplies are above their primary reset thresholds and the basic supply and clock infrastructure is available. During reset release at T3, the load jump of up to 150 mA (dI_{DD}) is expected.
- The power sequence as shown in [Figure 3-3](#) is enumerated below
 - T1 up to T2 refers to the period in time when basic supply and clock infrastructure components are available as the external supply ramps up. The bandgap and internal clock sources are started. The supply mode is evaluated based on the HWCFG[2:1,4,5,6] and TESTMODE pins. T1 up to T2 refers to the period in time when basic supply and clock infrastructure components are available as the external supply ramps up. The bandgap and internal clock sources are started. The supply mode is evaluated based on the HWCFG[2:1,6] pins. These events are initiated after LVD reset release at T1. LVD reset is released the both input voltages VEXT and VEVRSB are above VLVD RST5 and VLVD RSTSB levels correspondingly. Internal pre-regulator VDDPD output voltage is above VLVD RSTC level.
 - T2 refers to the point in time where consequently a soft start of EVRC and EVR33 regulators are initiated. PORST (input) does not have any affect on EVR33 or EVRC output and regulators continue to generate the respective voltages though PORST is asserted and the device is in reset state. The generated voltage follows a soft ramp-up over the t_{STR} (datasheet parameter) time to avoid overshoots.
 - T3 refers to the point in time when all supplies are above their primary reset thresholds denoted by VRST5, VRST33 and VRSTC supply voltage levels. EVRC and EVR33 regulators have ramped up. PORST (output) is de-asserted and HWCFG[3:5] pins are latched on PORST rising edge by SCU. Firmware execution is initiated. The time between T1 and T3 is documented as $t_{EVRstart}$ (datasheet parameter).
 - T4 refers to the point in time when Firmware execution is completed and User code execution starts with CPU0 at a default frequency of 100 MHz. The time between T0 and T4 is documented as t_{BP} (datasheet parameter).
 - T5 refers to the point in time during the ramp-down phase when at least one of the externally provided or generated supplies (VDD, VDDP3 or VEXT) drop below their respective primary under-voltage reset thresholds.

3.13.1.2 Single Supply mode (e)

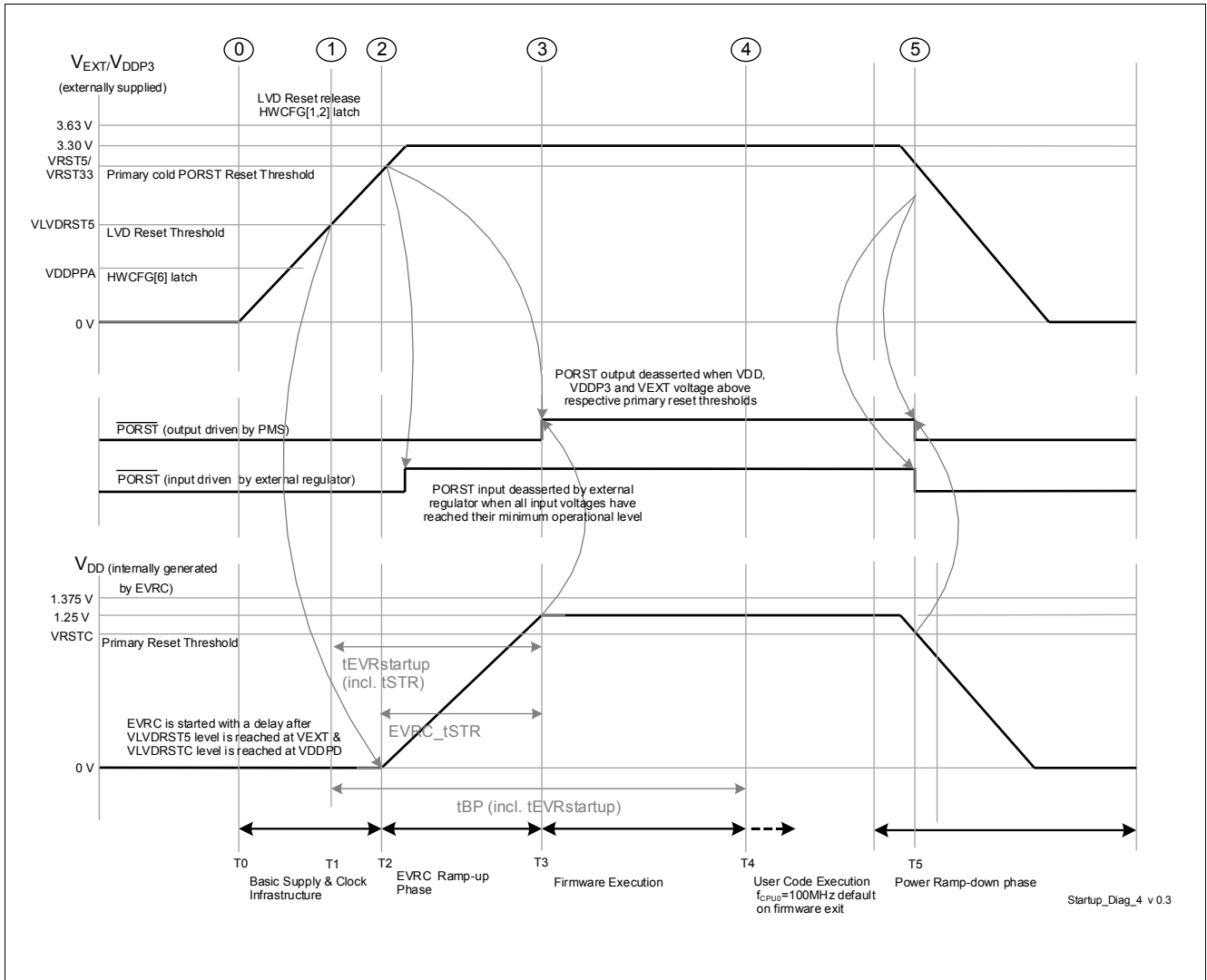

Figure 3-4 Single Supply mode (e) - (VEXT & VDDP3) 3.3 V single supply

VEXT = VDDP3 = 3.3 V single supply mode. VDD is generated internally by the EVRC regulator.

- The rate at which current is drawn from the external regulator (dI_{EXT}/dt) is limited in the Start-up phase to a maximum of 100 mA with 100 μ s settling time. Start-up slew rates for supply rails shall comply to datasheet parameter SR. The slope is defined as the maximal tangential slope between 0% to 100% voltage level. Actual waveform may not represent the specification.
- PORST is active/asserted when either PORST (input) or PORST (output) is active/asserted.
- PORST (input) active means that the reset is held active by external agents by pulling the PORST pin low. It is recommended to keep the PORST (input) asserted until the external supply is above the respective primary reset threshold.
- PORST (output) active means that μ C asserts the reset internally and drives the PORST pin low thus propagating the reset to external devices. The PORST (output) is asserted by the μ C when at least one among the three supply domains (VDD, VDDP3 or VEXT) violate their primary under-voltage reset thresholds. The PORST (output) is de-asserted by the μ C when all supplies are above their primary reset thresholds and the

Electrical Specification Power Supply Infrastructure and Supply Start-up

basic supply and clock infrastructure is available. During reset release at T3, the load jump of upto 150 mA (dIDD) is expected.

- The power sequence as shown in **Figure 3-4** is enumerated below
 - T1 up to T2 refers to the period in time when basic supply and clock infrastructure components are available as the external supply ramps up. The bandgap and internal clock sources are started. The supply mode is evaluated based on the HWCFG[2:1,4,5,6] and TESTMODE pins. T1 up to T2 refers to the period in time when basic supply and clock infrastructure components are available as the external supply ramps up. The bandgap and internal clock sources are started. The supply mode is evaluated based on the HWCFG[2:1,6] pins. These events are initiated after LVD reset release at T1. LVD reset is released the both input voltages VEXT and VEVRSB are above VLVD RST5 and VLVD RSTSB levels correspondingly. Internal pre-regulator VDDPD output voltage is above VLVD RSTC level.
 - T2 refers to the point in time where consequently a soft start of EVRC regulator is initiated. PORST (input) does not have any affect on EVRC output and regulators continue to generate the respective voltages though PORST is asserted and the device is in reset state. The generated voltage follows a soft ramp-up over the tSTR (datasheet parameter) time to avoid overshoots.
 - T3 refers to the point in time when all supplies are above their primary reset thresholds denoted by VRST5, VRST33 and VRSTC supply voltage levels. EVRC regulator has ramped up. PORST (output) is de-asserted and HWCFG[3:5] pins are latched on PORST rising edge by SCU. Firmware execution is initiated. The time between T1 and T3 is documented as tEVRstartup (datasheet parameter).
 - T4 refers to the point in time when Firmware execution is completed and User code execution starts with CPU0 at a default frequency of 100 MHz. The time between T0 and T4 is documented as tBP (datasheet parameter).
 - T5 refers to the point in time during the ramp-down phase when at least one of the externally provided or generated supplies (VDD, VDDP3 or VEXT) drop below their respective primary under-voltage reset thresholds.

Electrical Specification Power Supply Infrastructure and Supply Start-up

3.13.1.3 External Supply mode (d)

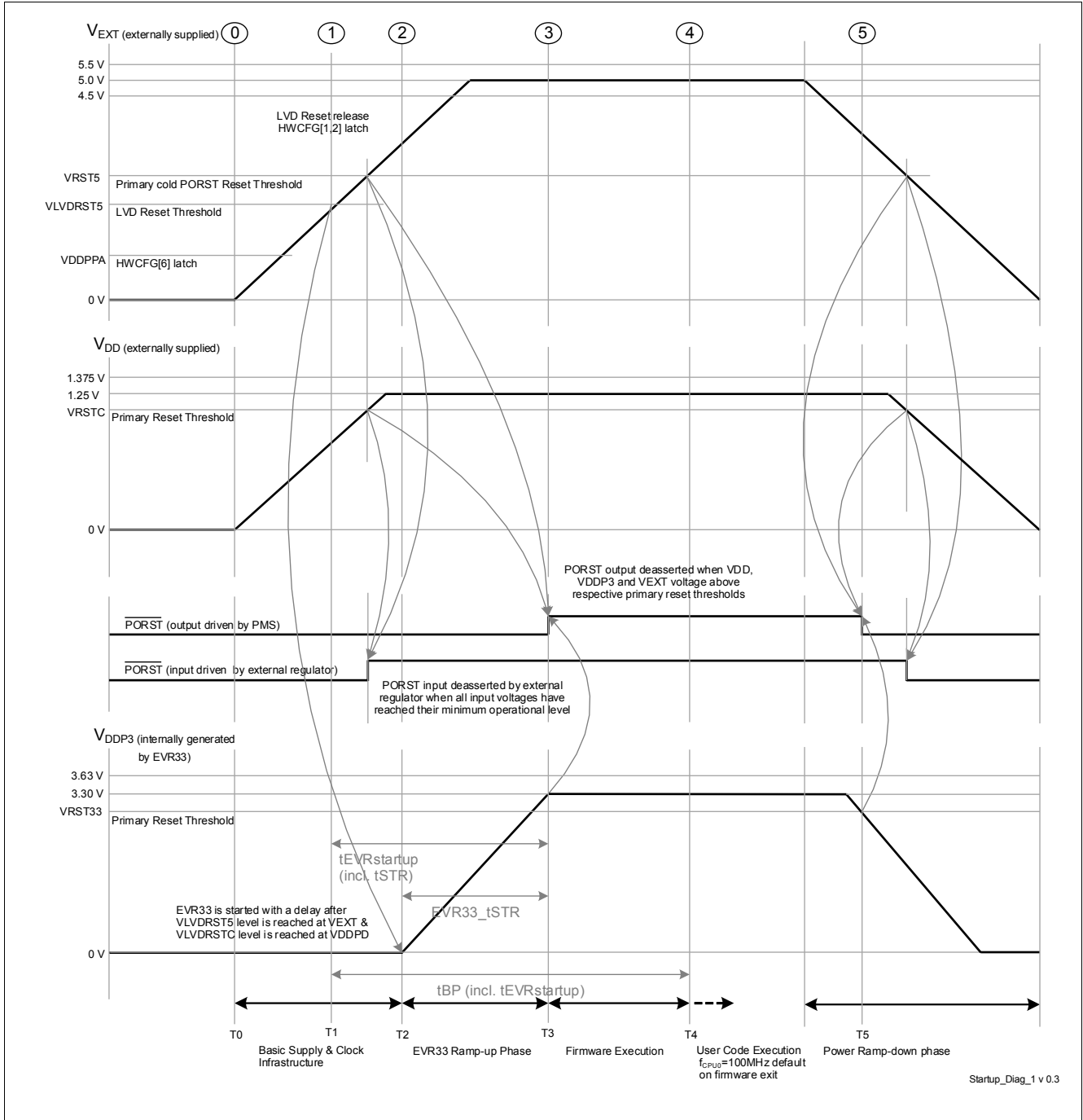

Figure 3-5 External Supply mode (d) - V_{EXT} and V_{DD} externally supplied

V_{EXT} = 5 V and V_{DD} supplies are externally supplied. 3.3V is generated internally by the EVR33 regulator.

- External supplies V_{EXT} and V_{DD} may ramp-up or ramp-down independent of each other with regards to start, rise and fall time(s). Start-up slew rates for supply rails shall comply to datasheet parameter SR. The slope is defined as the maximal tangential slope between 0% to 100% voltage level. Actual waveform may not represent the specification. It is expected that during start-up, V_{EXT} ramps up before V_{DD} rail.

Electrical Specification Power Supply Infrastructure and Supply Start-up

rail is ramped up before VEXT; VDD supply overshoots during start-up shall be limited within the operational voltage range.

- The rate at which current is drawn from the external regulator (dIEXT /dt or dIDD /dt) is limited in the Start-up phase to a maximum of 100 mA with 100 us settling time.
- PORST is active/asserted when either PORST (input) or PORST (output) is active/asserted.
- PORST (input) active means that the reset is held active by external agents by pulling the PORST pin low. It is recommended to keep the PORST (input) asserted until all the external supplies are above their primary reset thresholds.
- PORST (output) active means that μ C asserts the reset internally and drives the PORST pin low thus propagating the reset to external devices. The PORST (output) is asserted by the μ C when at least one among the three supply domains (VDD, VDDP3 or VEXT) violate their primary under-voltage reset thresholds. The PORST (output) is de-asserted by the μ C when all supplies are above their primary reset thresholds and the basic supply and clock infrastructure is available. During reset release at T3, the load jump of upto 150 mA (dIDD) is expected.
- The power sequence as shown in **Figure 3-5** is enumerated below
 - T1 up to T2 refers to the period in time when basic supply and clock infrastructure components are available as the external supply ramps up. The bandgap and internal clock sources are started. The supply mode is evaluated based on the HWCFG[2:1,4,5,6] and TESTMODE pins. T1 up to T2 refers to the period in time when basic supply and clock infrastructure components are available as the external supply ramps up. The bandgap and internal clock sources are started. The supply mode is evaluated based on the HWCFG[2:1,6] pins. These events are initiated after LVD reset release at T1. LVD reset is released the both input voltages VEXT and VEVR5B are above VLVD RST5 and VLVD RST5B levels correspondingly. Internal pre-regulator VDDPD output voltage is above VLVD RSTC level.
 - T2 refers to the point in time where consequently a soft start of EVR33 regulator is initiated. PORST (input) does not have any affect on EVR33 output and regulators continue to generate the respective voltages though PORST is asserted and the device is in reset state. The generated voltage follows a soft ramp-up over the tSTR (datasheet parameter) time to avoid overshoots.
 - T3 refers to the point in time when all supplies are above their primary reset thresholds denoted by VRST5, VRST33 and VRSTC supply voltage levels. EVR33 regulators has ramped up. PORST (output) is de-asserted and HWCFG[3:5] pins are latched on PORST rising edge by SCU. Firmware execution is initiated. The time between T1 and T3 is documented as tEVRstartup (datasheet parameter).
 - T4 refers to the point in time when Firmware execution is completed and User code execution starts with CPU0 at a default frequency of 100 MHz. The time between T0 and T4 is documented as tBP (datasheet parameter).
 - T5 refers to the point in time during the ramp-down phase when at least one of the externally provided or generated supplies (VDD, VDDP3 or VEXT) drop below their respective primary under-voltage reset thresholds.

3.13.1.4 External Supply mode (h)

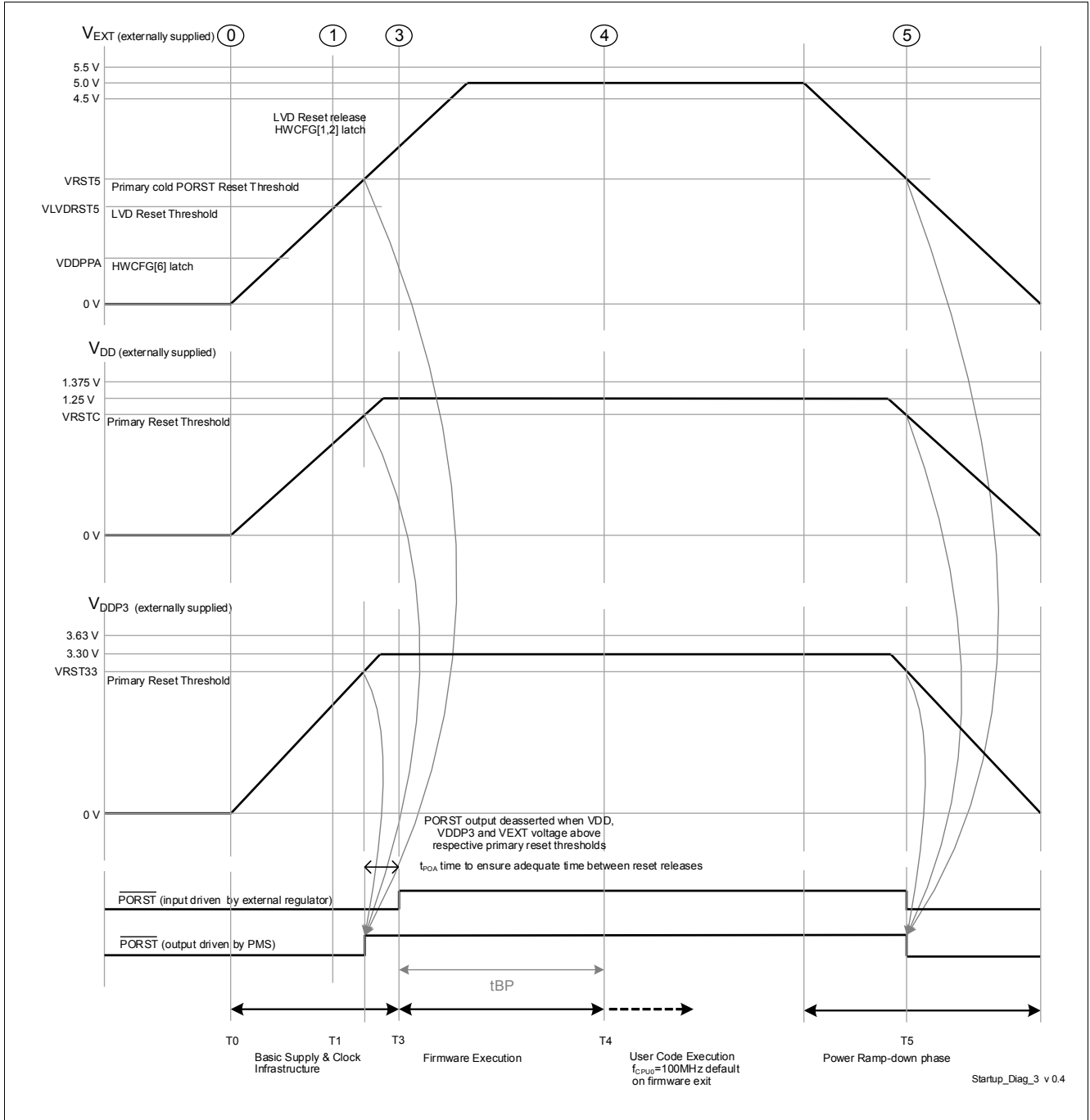

Figure 3-6 External Supply mode (h) - VEXT, VDDP3 & VDD externally supplied

All supplies, namely VEXT, VDDP3 & VDD are externally supplied.

- External supplies VEXT, VDDP3 & VDD may ramp-up or ramp-down independent of each other with regards to start, rise and fall time(s). Start-up slew rates for supply rails shall comply to datasheet parameter SR. The slope is defined as the maximal tangential slope between 0% to 100% voltage level. Actual waveform may not represent the specification. It is expected that during start-up, VEXT ramps up before VDDP3 and VDD rails. If smaller voltage rails are ramped up before VEXT; VDD and VDDP3 supply overshoots during start-up shall be limited within the operational voltage ranges of the respective rails.

Electrical Specification Power Supply Infrastructure and Supply Start-up

- The rate at which current is drawn from the external regulator (dI_{EXT}/dt , dI_{DD}/dt or dI_{DDP3}/dt) is limited in the Start-up phase to a maximum of 100 mA with 100 μ s settling time.
- PORST is active/asserted when either PORST (input) or PORST (output) is active/asserted.
- PORST (input) active means that the reset is held active by external agents by pulling the PORST pin low. It is recommended to keep the PORST (input) asserted until all the external supplies are above their primary reset thresholds.
- PORST (output) active means that μ C asserts the reset internally and drives the PORST pin low thus propagating the reset to external devices. The PORST (output) is asserted by the μ C when at least one among the three supply domains (VDD, VDDP3 or VEXT) violate their primary under-voltage reset thresholds. The PORST (output) is de-asserted by the μ C when all supplies are above their primary reset thresholds and the basic supply and clock infrastructure is available. During reset release at T3, the load jump of upto 150 mA (dI_{DD}) is expected.
- The power sequence as shown in [Figure 3-6](#) is enumerated below
 - T1 up to T3 refers to the period in time when basic supply and clock infrastructure components are available as the external supply ramps up. The bandgap and internal clock sources are started. The supply mode is evaluated based on the HWCFG[2:1,4,5,6] and TESTMODE pins. T1 up to T2 refers to the period in time when basic supply and clock infrastructure components are available as the external supply ramps up. The bandgap and internal clock sources are started. The supply mode is evaluated based on the HWCFG[2:1,6] pins. These events are initiated after LVD reset release at T1. LVD reset is released the both input voltages VEXT and VEVRSB are above VLVD RST5 and VLVD RSTSB levels correspondingly. Internal pre-regulator VDDPD output voltage is above VLVD RSTC level.
 - T3 refers to the point in time when all supplies are above their primary reset thresholds denoted by VRST5, VRST33 and VRSTC supply voltage levels. PORST (output) is de-asserted and HWCFG[3:5] pins are latched on PORST rising edge by SCU. Firmware execution is initiated.
 - T4 refers to the point in time when Firmware execution is completed and User code execution starts with CPU0 at a default frequency of 100 MHz. The time between T0 and T4 is documented as tBP (datasheet parameter).
 - T5 refers to the point in time during the ramp-down phase when at least one of the externally provided supplies (VDD, VDDP3 or VEXT) drop below their respective primary under-voltage reset thresholds.

3.14 Reset Timing

Table 3-30 Reset

Parameter	Symbol	Values			Unit	Note / Test Condition
		Min.	Typ.	Max.		
Application Reset Boot Time	t_B CC	-	-	400	μ s	operating with max. frequencies, with valid BMI header
System Reset Boot Time	t_{BS} CC	-	-	1.1	ms	RAM initialization and HSM boot time are not included, with valid BMI header
Cold Power on Reset Boot Time ¹⁾	t_{BP} CC	-	-	3.1	ms	$dV_{EXT}/dT=1V/ms$. $V_{EXT}>VLVDRST5$. Boot time after Cold PORST including EVR ramp-up and Firmware execution time; RAM initialization and HSM boot time are not included.
		-	-	1.6	ms	Firmware execution time after PORST release without EVR ramp-up; RAM initialization and HSM boot time is not included
Minimum cold PORST reset hold time incase of power fail event issued by EVR primary monitors	t_{EVRPOR} CC	10 ²⁾	-	-	μ s	
PMS Infrastructure, EVRC and EVR33 overall start-up time till cold PORST reset release	$t_{EVRstartup}$ CC	-	-	1	ms	$dV/dT=1V/ms$. EVRC and EVR33 active
Minimum PORST active hold time externally after power supplies are stable at operating levels after start-up	t_{POA} SR	1 ³⁾	-	-	ms	
Configurable PORST digital filter delay in addition to analog pad filter delay	$t_{PORSTDF}$ CC	600	-	1200	ns	
Warm Reset Sequencing Delay	$t_{WARMRSTSEQ}$ CC	-	-	180	μ s	
HWCFG pins hold time from ESR0 rising edge	t_{HDH} CC	$16 / f_{SPB}$	-	-	ns	

Electrical Specification Reset Timing
Table 3-30 Reset (cont'd)

Parameter	Symbol	Values			Unit	Note / Test Condition
		Min.	Typ.	Max.		
HWCFG pins setup time to ESR0 rising edge	t_{HDS} CC	0	-	-	ns	
Ports inactive after ESR0 reset active	t_{PI} CC	-	-	$8/f_{SPB}$	ns	
Ports inactive after PORST reset active	t_{PIP} CC	-	-	160	ns	
Hold time from PORST rising edge	t_{POH} SR	150	-	-	ns	
Setup time to PORST rising edge	t_{POS} SR	0	-	-	ns	
Warm PORST reset boot time	t_{BWP} CC	-	-	1.5	ms	without RAM initialization
LBIST execution time extending the boot time	t_{LBIST} CC	-	-	6	ms	LBIST Configuration A; $1.2V \leq V_{DD}$
SCR reset boot time	t_{SCR} CC	-	-	5	μs	User Mode 0
		-	-	16	μs	User Mode 1
		-	13.3	-	μs	WDT double bit ECC, soft reset
Minimum external supplies hold time after warm reset assertion	$t_{SUPHOLD}$ CC	-	-	250	μs	external supplies are V_{EVRSB} , V_{EXT} , $V_{FLEX/FLEX2}$, V_{DDM} , V_{DDP3} and V_{DD}

- 1) RAM initialization add 500 μs in addition.
- 2) Cold PORST reset is driven by uC and maintained in an extended voltage range between VDDPPA limit and absolute maximum rating voltage limits.
- 3) The reset release on supply ramp-up or supply restoration is delayed by a voltage hysteresis of 1.5% (default value) above the undervoltage reset limit implemented on VEXT, VDDP3 and VDD rails. This mechanism helps to avoid multiple consecutive cold PORST events during slow supply ramp-ups owing to voltage drop/current jumps when reset is released.

Electrical Specification Reset Timing

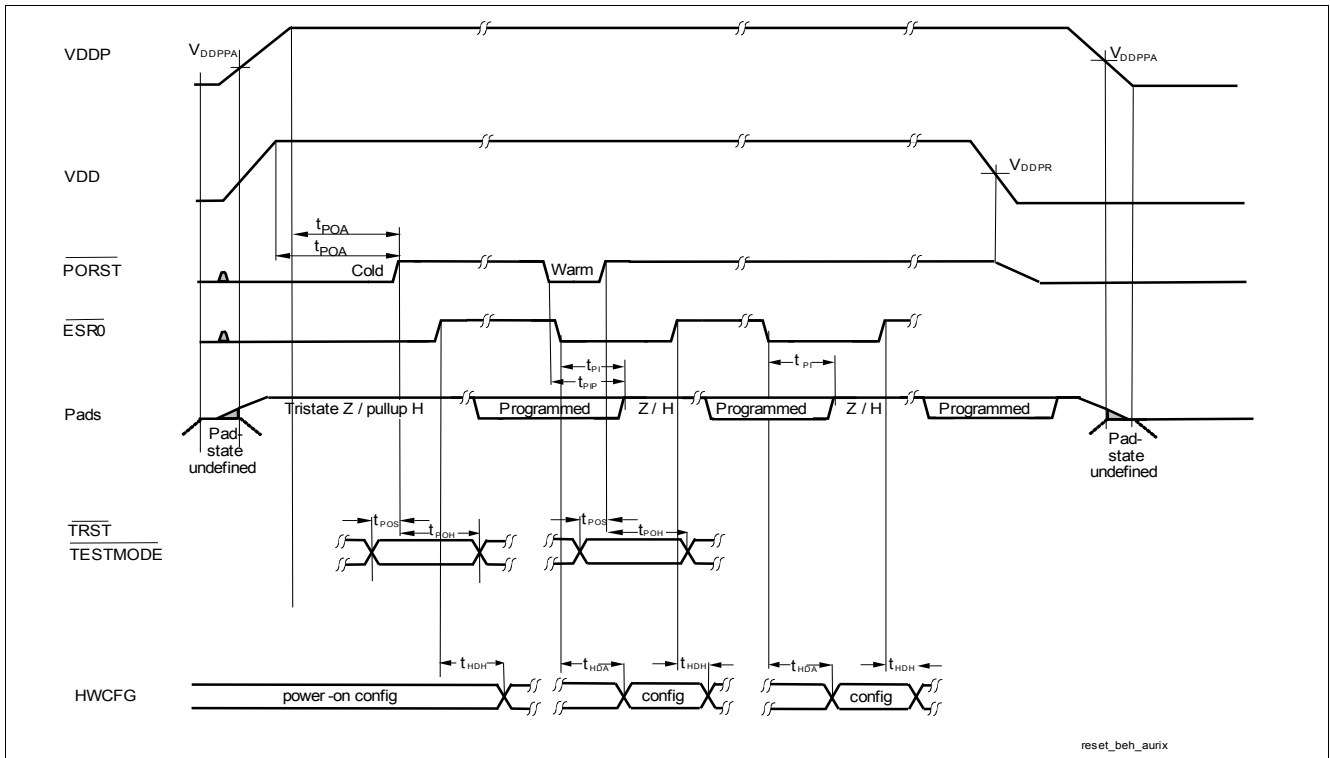

Figure 3-7 Power, Pad and Reset Timing

3.15 PMS
Table 3-31 EVR33 LDO

Parameter	Symbol	Values			Unit	Note / Test Condition
		Min.	Typ.	Max.		
Input voltage range	V_{IN} SR	3.60 ¹⁾	-	5.50	V	Normal RUN mode
		2.97 ²⁾	-	5.50	V	Low voltage cranking mode
Output voltage operational range including load/line regulation and aging ³⁾	V_{OUT} CC	2.97	3.3	3.63	V	Normal RUN mode
		2.60	3.3	3.63	V	Low voltage cranking mode; $I_{DDP3}=50mA$
Output V_{DDx3} static voltage accuracy after trimming and aging without dynamic load/line regulation.	V_{OUTT} CC	3.225	3.3	3.375	V	Normal RUN mode
		2.78	3.3	3.375	V	Low voltage cranking mode; $I_{DDP3}=50mA$
Output buffer capacitance on V_{OUT}	C_{OUT} SR	1.45	2.2	3	μF	
Output buffer capacitor ESR	C_{OUTESR} SR	-	-	100 ⁴⁾	mOhm	$f > 0.5MHz$; $f < 10MHz$
Maximum output current of the regulator	I_{MAX} CC	60 ⁵⁾	-	-	mA	Normal RUN mode
Startup time	t_{STR} CC	-	500	1000	μs	Normal RUN mode
External V_{IN} supply ramp ⁶⁾	dV_{in}/dt SR	-	1	-	V/ms	
Ripple on Output Voltage	ΔV_{OUTTC} CC	-	-	33	mV	$V_{EXT} \geq 2.97V$; $V_{EXT} \leq 5.5V$; $I_{OUTTC} \geq 10mA$; $I_{OUTTC} \leq 60mA$; ΔV_{OUTTC} = (peak to peak ripple / 2)
Load step response ⁷⁾	dV_{out}/dI_{out} CC	-165	-	-	mV	Normal RUN mode; $dI=10$ to $60mA$; $dt=20ns$; $T_{settle}=20us$
		-	-	165	mV	Normal RUN mode; $dI=60$ to $10mA$; $dt=20ns$; $T_{settle}=20us$
		-180	-	-	mV	Low voltage cranking mode; $dI=10$ to $50mA$; $dt=20ns$; $T_{settle}=20us$
		-	-	180	mV	Low voltage cranking mode; $dI=50$ to $10mA$; $dt=20ns$; $T_{settle}=20us$

Table 3-31 EVR33 LDO (cont'd)

Parameter	Symbol	Values			Unit	Note / Test Condition
		Min.	Typ.	Max.		
Line step response	dV_{out}/dV_{in} CC	-	-	40	mV	$dV_{in}/dT=1V/ms$; $dV=3.6$ to $5V$; $I_{MAX}=60mA$; ΔV_{OUTTC} is included
		-40	-	-	mV	$dV_{in}/dT=1V/ms$; $dV=5$ to $3.6V$; $I_{MAX}=60mA$; ΔV_{OUTTC} is included
		-	-	280	mV	$dV_{in}/dT=50V/ms$; $dV=3.6$ to $5V$; $I_{MAX}=60mA$
		-165	-	-	mV	$dV_{in}/dT=50V/ms$; $dV=5$ to $3.6V$; $I_{MAX}=60mA$

- 1) A maximum pass device dropout voltage of 300mV is included in the minimum input voltage to ensure optimal pass device performance during normal operation.
- 2) VEXT Input voltage drop up to 2.97V leading to VDDP3 output voltage drop upto 2.6V can be tolerated if Flash is switched before to low performance mode.
- 3) No external inductive load permissible if EVR33 is used.
- 4) It is also recommended that the resistance of the supply trace from the pin to the EVR output capacitor is less than 100 mOhm. An additional decoupling capacitor of 100nF shall be located close to the pin before Cout.
- 5) I_{MAX} is limited to 40 mA incase of Low voltage mode (cranking case) with on chip pass devices. In case EVR33 is not used, Injection current into 3.3V VDDP3 supply rail with active sink on 5V VEXT rail should be limited to 500 mA if during power sequencing 3.3V is supplied before 5V by external regulator.
- 6) EVR is robust against residual voltage ramp-up starting between 0 - 2.97 V. A VEXT voltage ramp range between 0.5V/min upto 120V/ms is covered in robustness validation. The generated voltage itself follows a soft ramp-up over the t_{STR} time to avoid overshoots.
- 7) Settling time is defined until output voltage is within +/-1% of the mean(V_{OUTT}) of the individual device.

Table 3-32 Supply Monitors

Parameter	Symbol	Values			Unit	Note / Test Condition
		Min.	Typ.	Max.		
Primary Undervoltage Reset threshold for V_{DDP3} before trimming ¹⁾	V_{RST33} CC	-	-	3.00	V	by reset release before EVR trimming on supply ramp-up
Primary undervoltage reset threshold for V_{DD} before trimming	V_{RSTC} CC	-	-	1.138	V	by reset release before trimming on supply ramp-up including 2 LSB voltage Hysteresis
V_{EXT} primary undervoltage monitor accuracy after trimming ²⁾	$V_{EXTPRIUV}$ CC	2.86	2.92	2.97	V	V_{EXT} = Undervoltage cold PORST Primary Monitor Threshold
V_{DDP3} primary undervoltage monitor accuracy after trimming ²⁾	$V_{DDP3PRIUV}$ CC	2.86 ³⁾	2.90	2.97	V	VDDP3 = Undervoltage cold PORST Primary Monitor Threshold

Table 3-32 Supply Monitors (cont'd)

Parameter	Symbol	Values			Unit	Note / Test Condition
		Min.	Typ.	Max.		
V_{DD} primary undervoltage monitor accuracy after trimming ²⁾	$V_{DDPRIUV}$ CC	1.08 ³⁾	1.105	1.125	V	VDD = Undervoltage cold PORST Primary Monitor Threshold
EVR primary monitor measurement latency for a new supply value	t_{PRIUV} CC	-	-	300	ns	The supply ramp / line jump slope is limited to 50V/ms for V_{EXT} , V_{DDP3} and V_{DD} rails.

Table 3-32 Supply Monitors (cont'd)

Parameter	Symbol	Values			Unit	Note / Test Condition
		Min.	Typ.	Max.		
V_{EXT} , V_{DDM} & V_{EVRSB} secondary supply monitor accuracy after trimming ⁴⁾ ⁵⁾	V_{EXTMON} CC	3.2	3.3	3.4	V	SWDxxVAL, VDDMxxVAL & SBxxVAL monitoring threshold=3.3V=90h(OV,UV). For BGA packages: EVRMONFILT.SWDFI L=1.
		3.2	3.3	3.4	V	SWDxxVAL, VDDMxxVAL & SBxxVAL monitoring threshold=3.3V=90h(OV,UV). For QFP packages: EVRMONFILT.SWDFI L=2
		4.5	4.6	4.7	V	SWDxxVAL, VDDMxxVAL & SBxxVAL monitoring threshold=4.6V=C8h(UV)/C9h(OV). For BGA packages: EVRMONFILT.SWDFI L=1
		4.5	4.6	4.7	V	SWDxxVAL, VDDMxxVAL & SBxxVAL monitoring threshold=4.6V=C8h(UV)/C9h(OV). For QFP packages: EVRMONFILT.SWDFI L=2
		5.3	5.4	5.5	V	SWDxxVAL, VDDMxxVAL & SBxxVAL monitoring threshold=5.4V=EAh(UV)/ECh(OV). For BGA packages: EVRMONFILT.SWDFI L=1
		5.3	5.4	5.5	V	SWDxxVAL, VDDMxxVAL & SBxxVAL monitoring threshold=5.4V=EAh(UV)/ECh(OV). For QFP packages: EVRMONFILT.SWDFI L=2
		4.9	5.0	5.1	V	SWDxxV VDDMxxVAL & SBxxVAL monitoring

Table 3-32 Supply Monitors (cont'd)

Parameter	Symbol	Values			Unit	Note / Test Condition
		Min.	Typ.	Max.		
V_{DDP3} secondary supply monitor accuracy after trimming ⁵⁾	$V_{DDP3MON}$ CC	2.97	3.035	3.1	V	EVR33xxVAL monitoring threshold=3.035V=CBh(UV)/CCh(OV). EVRMONFILT.EVR33 FIL = 3.
		3.235	3.30	3.365	V	EVR33xxVAL monitoring threshold=3.3V=DDh(OV,UV). EVRMONFILT.EVR33 FIL = 3.
		3.5	3.565	3.63	V	EVR33xxVAL monitoring threshold=3.565V=EEh(UV)/EFh(OV). EVRMONFILT.EVR33 FIL = 3.
V_{DD} & V_{DDPD} secondary supply monitor accuracy after trimming ⁵⁾	V_{DDMON} CC	1.125	1.15	1.175	V	EVRCxxVAL & PRExxVAL monitoring threshold=1.15V=C7h(UV)/C8h(OV). EVRMONFILT.EVRC FIL = 1.
		1.225	1.25	1.275	V	EVRCxxVAL & PRExxVAL monitoring threshold=1.25V=D9h(OV,UV). EVRMONFILT.EVRC FIL = 1.
		1.325	1.35	1.375	V	EVRCxxVAL & PRExxVAL monitoring threshold=1.35V=EAh(UV)/EBh(OV). EVRMONFILT.EVRC FIL = 1.
V_{EXT} LVD Primary undervoltage reset Monitor threshold	$V_{LVDRST5}$ CC	2.3	-	2.72	V	Power-down
		2.4	-	2.75	V	Power-up
V_{EVR5B} LVD Primary undervoltage reset Monitor threshold	$V_{LVDRST5B}$ CC	2.18	-	2.47	V	Power-down
		2.21	-	2.5	V	Power-up
V_{EXT} and V_{EVR5B} PBIST primary overvoltage Monitor threshold	V_{PBIST5} CC	5.63	-	-	V	

Table 3-32 Supply Monitors (cont'd)

Parameter	Symbol	Values			Unit	Note / Test Condition
		Min.	Typ.	Max.		
Primary undervoltage reset threshold for V_{EXT} before trimming	$V_{RST5} CC$	-	-	3.0	V	by last cold PORST release on supply ramp-up including voltage hysteresis.
EVR secondary monitor measurement latency for all 6 supply rails	$t_{MON} CC$	-	-	3.2	μs	HPOSC and SHPBG bandgap trimmed. Filter inactive.

- 1) The reset release on supply ramp-up is delayed by a time duration 20-40 μs after reaching undervoltage reset threshold and by a voltage hysteresis of 1.5% above the undervoltage reset limit. These mechanisms serve as hysteresis to avoid multiple consecutive cold PORST events during slow supply ramp-ups owing to voltage drop/current jumps when reset is released. The reset limit of 2.97V at pin is for the case with 3.3V generated internally from EVR33. In case the 3.3V supply is provided externally, the bondwire drop will cause a reset at a higher voltage of 3.0V at the VDDP3 pin.
- 2) The monitor tolerances constitute the inherent variation of the band gap and ADC over process, voltage and temperature operational ranges. The $V_{xxPRIUV}$ parameters are device individually tested in production with +/-1% tolerance about the $V_{xxPRIUV}$ limits. All voltages are measured on pins.
- 3) $VRST_{xx}$ parameters are relevant only for the first cold PORST release. Later the reset levels are trimmed by the Firmware and reflected as $V_{xxPRIUV}$ parameters before device is used with full performance. The cold PORST is released with a voltage hysteresis on all the primary monitors to avoid consecutive PORST toggling behavior.
- 4) In case the application is using 3.3V single supply (Single Supply mode (e), i.e. V_{EXT} and VDDP3 are shorted together), it is recommended to use secondary supply monitoring on channel VDDP3, because of the better accuracy of parameter VDDP3MON.
- 5) To monitor voltage level not provided in conditions the values for OV and UV thresholds can be generated by a linear interpolation or extrapolation based on the given points.

Table 3-33 Supply Ramp

Parameter	Symbol	Values			Unit	Note / Test Condition
		Min.	Typ.	Max.		
External V_{EXT} & V_{EVRSB} supply ramp-up and ramp-down slope 1) 2) 3)	dV_{EXT}/dt SR	8.3E-6	1	100	V/ms	
External V_{DDP3} supply ramp-up and ramp-down slope ¹⁾³⁾	dV_{DDP3}/dt SR	8.3E-6	1	100	V/ms	
External V_{DD} supply ramp-up and ramp-down slope ¹⁾³⁾	dV_{DD}/dt SR	8.3E-6	1	100	V/ms	
External V_{DDM} supply ramp-up and ramp-down slope ¹⁾³⁾	dV_{DDM}/dt SR	8.3E-6	1	100	V/ms	

- 1) The device is robust against residual voltage ramp-up starting between 0 - 2.97 V for V_{EXT} , V_{EVRSB} , VDDP3 and VDDM and 0-1 V for VDD. A voltage ramp range between 0.5V/min upto 120V/ms is covered in robustness validation.
 - 2) Also valid incase EVR33 or EVRC is used. The generated voltage itself follows a soft ramp-up over the t_{STR} time to avoid overshoots.
 - 3) The slope is defined as the maximal tangential slope between 0% to 100% voltage level. Actual waveform may not represent the specification.
- Up to 1000000 power-cycles, matching the limits defined in the table 'Supply Ramp' are allowed for TC38x, without any restriction to reliability.

Table 3-34 EVRC SMPS

Parameter	Symbol	Values			Unit	Note / Test Condition
		Min.	Typ.	Max.		
Input V_{EXT} Voltage range	V_{IN} SR	2.97	-	5.5	V	Start-up VEXT voltage > 2.6 V
SMPS regulator output voltage range including load/line regulation and aging	V_{DDDC} CC	1.125	-	1.375	V	$V_{EXT} \geq 2.97V$; $V_{EXT} \leq 5.5V$; $I_{DDDC} \geq 1mA$; $I_{DDDC} \leq 1.5A$; untrimmed
SMPS regulator static voltage output accuracy after trimming without dynamic load/line regulation.	$V_{DDDC T}$ CC	1.225	1.25	1.275	V	$V_{EXT} \geq 2.97V$; $V_{EXT} \leq 5.5V$; $I_{DDDC} \geq 1mA$; $I_{DDDC} \leq 1.5A$
Programmable switching frequency	f_{DCDC} SR	1.6	1.82	2.0	MHz	Start-up frequency switches from 500 KHz in open loop operation to 1.82 MHz in closed loop Operation.
		-	0.8	-	MHz	Start-up frequency switches from 500 KHz in open loop operation to 1.82 MHz in closed loop Operation. 0.8 MHz to be set in SW.
Startup time	t_{STRDC} CC	-	-	900	μs	SMPS Start-up Mode. It is defined between $V_{EXTPRIUV}$ reset threshold till PORST release, on condition that all other PORST requirements were released before. $I_{START} < 700mA$.
Switching frequency modulation spread	Δf_{DCSPR} CC	-	1.8%	-	MHz	
Maximum ripple at I_{MAX}	ΔV_{DDDC} CC	-	-	16	mV	$V_{EXT} \geq 2.97V$; $V_{EXT} \leq 5.5V$; $I_{DDDC} \geq 300mA$; $I_{DDDC} \leq 1.5A$; $\Delta V_{DDDC} = (\text{Peak to Peak ripple} / 2)$
No load current consumption of SMPS regulator	I_{DCNL} CC	-	15	19	mA	$f_{DCDC}=1.82MHz$; $I_{DDDC}=I_{SLEEP}$; $V_{EXT} > 2.97 V$; $T_J=25^\circ C$
		-	5	-	mA	LPM mode; $I_{DDDC}=I_{SLEEP}$; $V_{EXT} > 2.97 V$; $T_J=25^\circ C$

Table 3-34 EVRC SMPS (cont'd)

Parameter	Symbol	Values			Unit	Note / Test Condition
		Min.	Typ.	Max.		
SMPS regulator load transient response	$dV_{DDDC} / dl_{OUT} CC$	-50	-	75	mV	$dI < -250mA$; $I_{DDDC}=280-1500mA$; $t_r=0.1\mu s$; $t_f=0.1\mu s$; $V_{DDDC}=1.25V$; $T_{settle}=100\mu s$
		-50	-	87	mV	$dI < -450mA$; $I_{DDDC}=500-1500mA$; $t_r=0.1\mu s$; $t_f=0.1\mu s$; $V_{DDDC}=1.25V$; $T_{settle}=100\mu s$
		-100	-	145	mV	$dI < -700mA$; $I_{DDDC}=750-1500mA$; $t_r=0.1\mu s$; $t_f=0.1\mu s$; $V_{DDDC}=1.25V$; $T_{settle}=100\mu s$
		-26	-	26	mV	$dI < 100mA$; $I_{DDDC}=50-1500mA$; $t_r=0.1\mu s$; $t_f=0.1\mu s$; $V_{DDDC}=1.25V$; $T_{settle}=20\mu s$;
Maximum output current	$I_{MAX} CC$	100	-	-	mA	LPM mode. Typical current in LPM Mode = I_{SLEEP}
		1.5	-	-	A	limited by thermal constraints and component choice
SMPS regulator line transient response	$dV_{DDDC} / dV_{IN} CC$	-75	-	75	mV	$dV/dT=120V/ms$; $dV < 2.97 - 5.5V$; $I_{DDDC}=50-1500mA$;
		-12.5	-	12.5	mV	$dV/dT=1V/ms$; $dV < 2.97 - 5.5V$; $I_{DDDC}=50-1500mA$;
SMPS regulator efficiency	$n_{DC} CC$	-	80	-	%	$V_{IN}=3.3V$; $I_{DDDC}=1500mA$; $f_{DCDC}=1.82MHz$
		-	75	-	%	$V_{IN}=5V$; $I_{DDDC}=1500mA$; $f_{DCDC}=1.82MHz$
Input Synchronisation frequency	$f_{DCDCSYNC} SR$	1.6	1.82	2.0	MHz	

Table 3-35 EVRC SMPS External components

Parameter	Symbol	Values			Unit	Note / Test Condition
		Min.	Typ.	Max.		
External output capacitor value ¹⁾	C_{OUT} SR	20.8	32	43.2	μF	$I_{DDDC}=1.5\text{A}; f_{DDDC} = 0.8\text{MHz}$
		15.4	22	29.7	μF	$I_{DDDC}=1.5\text{A}; f_{DDDC} = 1.82\text{MHz}$
External output capacitor ESR	C_{OUT_ESR} SR	-	-	50	mOhm	$f \geq 0.5\text{MHz}; f \leq 10\text{MHz}$
		-	-	100	Ohm	$f=10\text{Hz}$
External input capacitor value ¹⁾	C_{IN} SR	6.5	10	13.5	μF	$I_{DDDC}=1.5\text{A}$
		4.42	6.8	9.18	μF	$I_{DDDC}=500\text{mA}$
External input capacitor ESR	C_{IN_ESR} SR	-	-	50	mOhm	$f \geq 0.5\text{MHz}; f \leq 10\text{MHz}$
		-	-	100	Ohm	$f=100\text{Hz}$
External inductor value	L_{DC} SR	3.29	4.7	6.11		$f_{DCDC}=0.8\text{MHz}$
		2.31	3.3	4.29	μH	$f_{DCDC}=1.82\text{MHz}$
External inductor DCR	L_{DC_DCR} SR	-	-	0.2	Ohm	
P + N-channel MOSFET logic level	V_{LL} SR	-	-	2.5	V	
P + N-channel MOSFET drain source breakdown voltage	$ V_{BR_DS} $ SR	+7	-	-	V	NMOS - $V_{GS} = 0$.
		-	-	-7	V	PMOS - $V_{GS} = 0$.
P + N-channel MOSFET drain source ON-state resistance	R_{ON} SR	-	-	150	mOhm	$I_{DDDC}=1.5\text{A}; V_{GS} =2.5\text{V}; T_A=25^\circ\text{C}$
		-	-	200	mOhm	$I_{DDDC}=500\text{mA}; V_{GS} =2.5\text{V}; T_A=25^\circ\text{C}$
P + N-channel MOSFET Gate Charge	Q_G SR	-	-	8	nC	$I_{DDDC}=1.5\text{A}; \text{NMOS-} V_{GS} =5\text{V}; 1.5\text{A pulsed drain current}$
		-8	-	-	nC	$I_{DDDC}=1.5\text{A}; \text{PMOS-} V_{GS} =5\text{V}; 1.5\text{A pulsed drain current}$
		-	-	4	nC	$I_{DDDC}=500\text{mA}; \text{NMOS-} V_{GS} =5\text{V}; 0.5\text{A pulsed drain current}$
		-4	-	-	nC	$I_{DDDC}=500\text{mA}; \text{PMOS-} V_{GS} =5\text{V}; 0.5\text{A pulsed drain current}$
External Inductor Saturation Current Margin	ΔI_{SAT} SR	400	-	-	mA	The saturation current of the coil must be larger than $I_{DDDC} + \Delta I_{SAT}$

Table 3-35 EVRC SMPS External components (cont'd)

Parameter	Symbol	Values			Unit	Note / Test Condition
		Min.	Typ.	Max.		
P + N-channel MOSFET Gate threshold voltage	$V_{G\text{STH}}$ SR	-	1	-	V	NMOS
		-	-1	-	V	PMOS
N-channel MOSFET reverse diode forward voltage	$V_{R\text{DN}}$ SR	-	0.8	-	V	

1) Capacitor min-max range represent typical +-35% tolerance including DC bias effect. The trace resistance from the capacitor to the supply or ground rail should be limited to 25 mOhm.

3.16 System Phase Locked Loop (SYS_PLL)

Table 3-36 PLL System

Parameter	Symbol	Values			Unit	Note / Test Condition
		Min.	Typ.	Max.		
DCO Input frequency range	f_{REF} CC	10	-	40	MHz	
Modulation Amplitude	MA CC	0	-	2	%	
Peak Period jitter	DP CC	-200	-	200	ps	without modulation (PLL output frequency)
Peak Accumulated Jitter	D_{PP} CC	-5	-	5	ns	without modulation
Total long term jitter	J_{TOT} CC	-	-	11.5	ns	including modulation; MA 1.25%; f_{REF} 20MHz
System frequency deviation	f_{SYSD} CC	-	-	0.01	%	with active modulation
DCO frequency range	f_{DCO} CC	400	-	800	MHz	
PLL lock-in time	t_L CC	4	-	100	μ s	

Note: The specified PLL jitter values are valid if the capacitive load per pin does not exceed $C_L = 20$ pF with the maximum driver and sharp edge.

Note: The maximum peak-to-peak noise on the power supply voltage, is limited to a peak-to-peak voltage of $V_{PP} = 100$ mV for noise frequencies below 300 KHz and $V_{PP} = 40$ mV for noise frequencies above 300 KHz. These conditions can be achieved by appropriate blocking of the supply voltage as near as possible to the supply pins and using PCB supply and ground planes.

3.17 Peripheral Phase Locked Loop (PER_PLL)

Table 3-37 PLL Peripheral

Parameter	Symbol	Values			Unit	Note / Test Condition
		Min.	Typ.	Max.		
Peak Accumulated jitter at SYSCLK pin	D_{PP} CC	-1000	-	1000	ps	Peak only
Peak accumulated jitter	D_{PPI} CC	-700	-	700	ps	Peak only
RMS Accumulated jitter	D_{RMS} CC	-100	-	100	ps	measured over 1 μ s; $f_{REF} = 20$ MHz and $f_{DCO} = 640$ MHz or $f_{REF} = 25$ MHz and $f_{DCO} = 800$ MHz
Peak Period jitter	DP CC	-200	-	200	ps	$f_{DCO} = 640$ MHz or $f_{DCO} = 800$ MHz
Absolute RMS jitter (PLL out)	J_{ABS10} CC	-125	-	125	ps	$f_{REF} = 10$ MHz; $f_{DCO} = 640$ MHz
Absolute RMS jitter (PLL out)	J_{ABS20} CC	-85	-	85	ps	$f_{REF} = 20$ MHz; $f_{DCO} = 640$ MHz
Absolute RMS jitter (PLL out)	J_{ABS25} CC	-85	-	85	ps	$f_{REF} = 25$ MHz; $f_{DCO} = 800$ MHz
DCO frequency range	f_{DCO} CC	400	-	800	MHz	
DCO input frequency range	f_{REF} CC	10	-	40	MHz	
PLL lock-in time	t_L CC	4	-	100	μ s	

Note: The specified PLL jitter values are valid if the capacitive load per pin does not exceed $C_L = 20$ pF with the maximum driver and sharp edge.

Note: The maximum peak-to-peak noise on the power supply voltage, is limited to a peak-to-peak voltage of $V_{PP} = 100$ mV for noise frequencies below 300 KHz and $V_{PP} = 40$ mV for noise frequencies above 300 KHz. These conditions can be achieved by appropriate blocking of the supply voltage as near as possible to the supply pins and using PCB supply and ground planes.

3.18 AC Specifications

All AC parameters are specified for the complete operating range defined in [Chapter 3.4](#) unless otherwise noted in column Note / Test Condition.

Unless otherwise noted in the figures the timings are defined with the following guidelines:

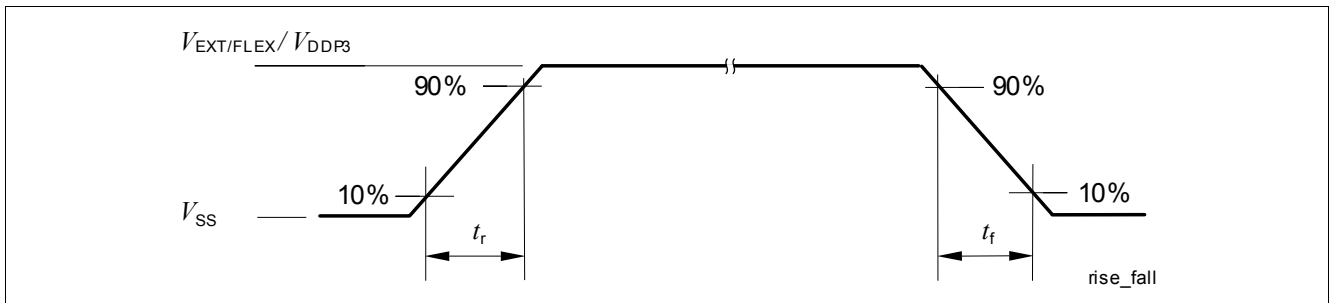

Figure 3-8 Definition of rise / fall times

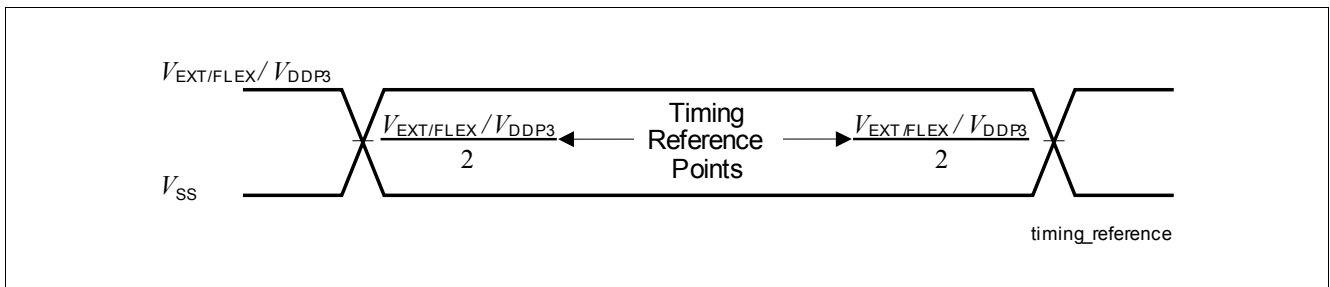

Figure 3-9 Time Reference Point Definition

3.19 JTAG Parameters

The following parameters are applicable for communication through the JTAG debug interface. The JTAG module is fully compliant with IEEE1149.1-2000.

Table 3-38 JTAG

Parameter	Symbol	Values			Unit	Note / Test Condition
		Min.	Typ.	Max.		
TCK clock period	t_1 SR	50	-	-	ns	
TCK high time	t_2 SR	10	-	-	ns	
TCK low time	t_3 SR	10	-	-	ns	
TCK clock rise time	t_4 SR	-	-	4	ns	
TCK clock fall time	t_5 SR	-	-	4	ns	
TDI/TMS setup to TCK rising edge	t_6 SR	6.0	-	-	ns	
TDI/TMS hold after TCK rising edge	t_7 SR	6.0	-	-	ns	
TDO valid after TCK falling edge (propagation delay)	t_8 CC	3.0	-	-	ns	$C_L \leq 20\text{pF}$
		-	-	25	ns	$C_L \leq 50\text{pF}$
TDO hold after TCK falling edge	t_{18} CC	2	-	-	ns	
TDO high impedance to valid from TCK falling edge	t_9 CC	-	-	25	ns	$C_L \leq 50\text{pF}$
TDO valid output to high impedance from TCK falling edge	t_{10} CC	-	-	25	ns	$C_L \leq 50\text{pF}$

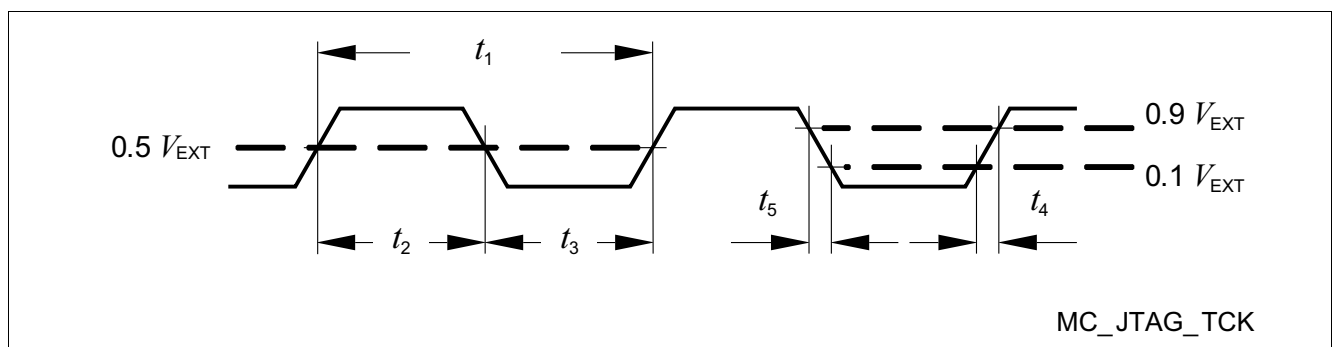
Figure 3-10 Test Clock Timing (TCK)

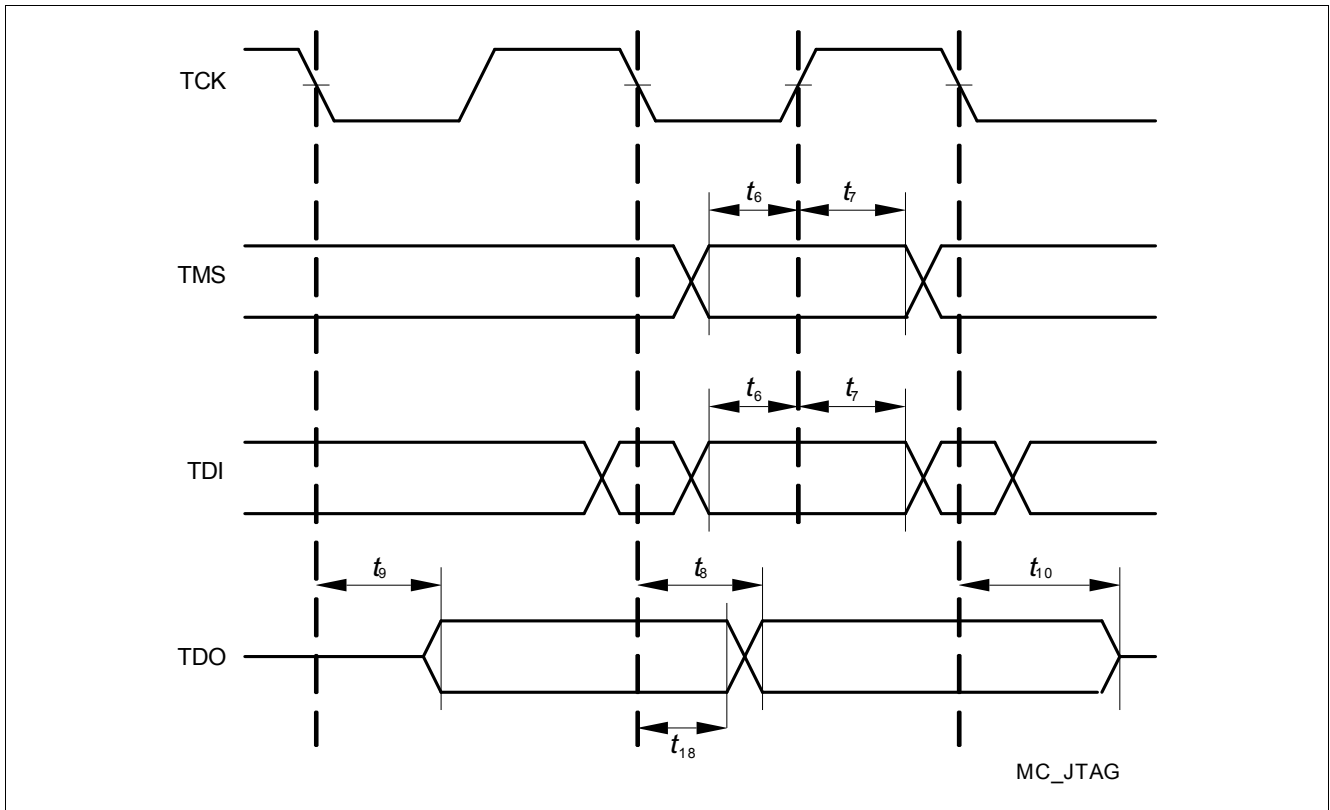

Figure 3-11 JTAG Timing

3.20 DAP Parameters

The following parameters are applicable for communication through the DAP debug interface.

Table 3-39 DAP

Parameter	Symbol	Values			Unit	Note / Test Condition
		Min.	Typ.	Max.		
DAP0 clock rise time	t_{14} SR	-	-	1	ns	f=160MHz
		-	-	4	ns	f=40MHz
		-	-	2	ns	f=80MHz
DAP0 clock fall time	t_{15} SR	-	-	1	ns	f=160MHz
		-	-	4	ns	f=40MHz
		-	-	2	ns	f=80MHz
DAP1 setup to DAP0 rising edge	t_{16} SR	4	-	-	ns	
		5	-	-	ns	f=40MHz
DAP1 hold after DAP0 rising edge	t_{17} SR	2	-	-	ns	
DAP1 valid per DAP0 clock period	t_{19} CC	4	-	-	ns	$C_L=20\text{pF}$; f=160MHz
		8	-	-	ns	$C_L=20\text{pF}$; f=80MHz
		10	-	-	ns	$C_L=50\text{pF}$; f=40MHz
DAP0 high time	t_{12} SR	2	-	-	ns	
DAP0 low time	t_{13} SR	2	-	-	ns	
DAP0 clock period	t_{11} SR	6.25	-	-	ns	

Table 3-40 SCR DAP

Parameter	Symbol	Values			Unit	Note / Test Condition
		Min.	Typ.	Max.		
DAP0 clock rise time	t_{14} SR	-	-	8	ns	f=20MHz
DAP0 clock fall time	t_{15} SR	-	-	8	ns	f=20MHz
DAP1 setup to DAP0 rising edge	t_{16} SR	10	-	-	ns	
DAP1 hold after DAP0 rising edge	t_{17} SR	10	-	-	ns	
DAP1 valid per DAP0 clock period	t_{19} CC	30	-	-	ns	$C_L=20\text{pF}$; f=20MHz
DAP0 high time	t_{12} SR	15	-	-	ns	
DAP0 low time	t_{13} SR	15	-	-	ns	
DAP0 clock period	t_{11} SR	50	-	-	ns	

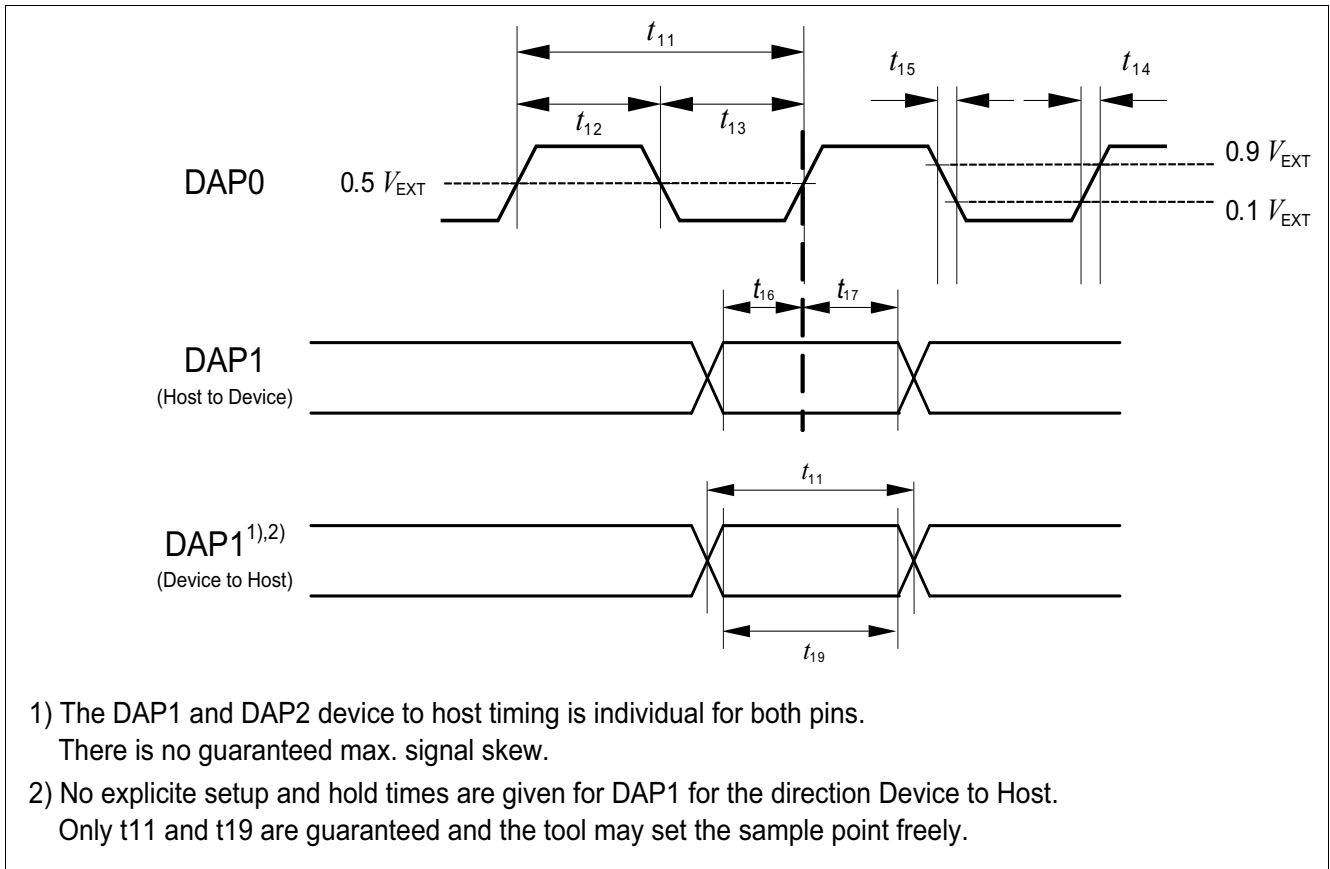

Figure 3-12 DAP Timing

Note: The DAP1 and DAP2 device to host timing is individual for both pins. There is no guaranteed max. signal skew.

3.21 ASCLIN SPI Master Timing

This section defines the timings for the ASCLIN in the TC37xEXT.

Note: Pad asymmetry is already included in the following timings.

Table 3-41 Master Mode strong sharp (ss) output pads

Parameter	Symbol	Values			Unit	Note / Test Condition
		Min.	Typ.	Max.		
ASCLKO clock period	t_{50} CC	20	-	-	ns	$C_L=25\text{pF}$
Deviation from ideal duty cycle	t_{500} CC	-2	-	2	ns	$C_L=25\text{pF}$
MISR delay from ASCLKO shifting edge	t_{51} CC	-3.5	-	3.5	ns	$C_L=25\text{pF}$
ASLSON delay from the first ASCLKO edge	t_{510} CC	-3	-	3.5	ns	$C_L=25\text{pF}$
MRST setup to ASCLKO latching edge	t_{52} SR	25	-	-	ns	$C_L=25\text{pF}$
MRST hold from ASCLKO latching edge	t_{53} SR	-2	-	-	ns	$C_L=25\text{pF}$

Table 3-42 Master Mode strong medium (sm) output pads

Parameter	Symbol	Values			Unit	Note / Test Condition
		Min.	Typ.	Max.		
ASCLKO clock period	t_{50} CC	50	-	-	ns	$C_L=50\text{pF}$
Deviation from ideal duty cycle	t_{500} CC	-5	-	5	ns	$C_L=50\text{pF}$
MISR delay from ASCLKO shifting edge	t_{51} CC	-7	-	7	ns	$C_L=50\text{pF}$
ASLSON delay from the first ASCLKO edge	t_{510} CC	-7	-	7	ns	$C_L=50\text{pF}$
MRST setup to ASCLKO latching edge	t_{52} SR	35	-	-	ns	$C_L=50\text{pF}$
MRST hold from ASCLKO latching edge	t_{53} SR	-5	-	-	ns	$C_L=50\text{pF}$

Table 3-43 Master Mode medium (m) output pads

Parameter	Symbol	Values			Unit	Note / Test Condition
		Min.	Typ.	Max.		
ASCLKO clock period	t_{50} CC	160	-	-	ns	$C_L=50\text{pF}$
Deviation from ideal duty cycle	t_{500} CC	-10	-	10	ns	$C_L=50\text{pF}$
MISR delay from ASCLKO shifting edge	t_{51} CC	-20	-	20	ns	$C_L=50\text{pF}$
ASLSON delay from the first ASCLKO edge	t_{510} CC	-20	-	20	ns	$C_L=50\text{pF}$

Electrical Specification ASCLIN SPI Master Timing

Table 3-43 Master Mode medium (m) output pads (cont'd)

Parameter	Symbol	Values			Unit	Note / Test Condition
		Min.	Typ.	Max.		
MRST setup to ASCLKO latching edge	t_{52} SR	80	-	-	ns	$C_L=50\text{pF}$
MRST hold from ASCLKO latching edge	t_{53} SR	-15	-	-	ns	$C_L=50\text{pF}$

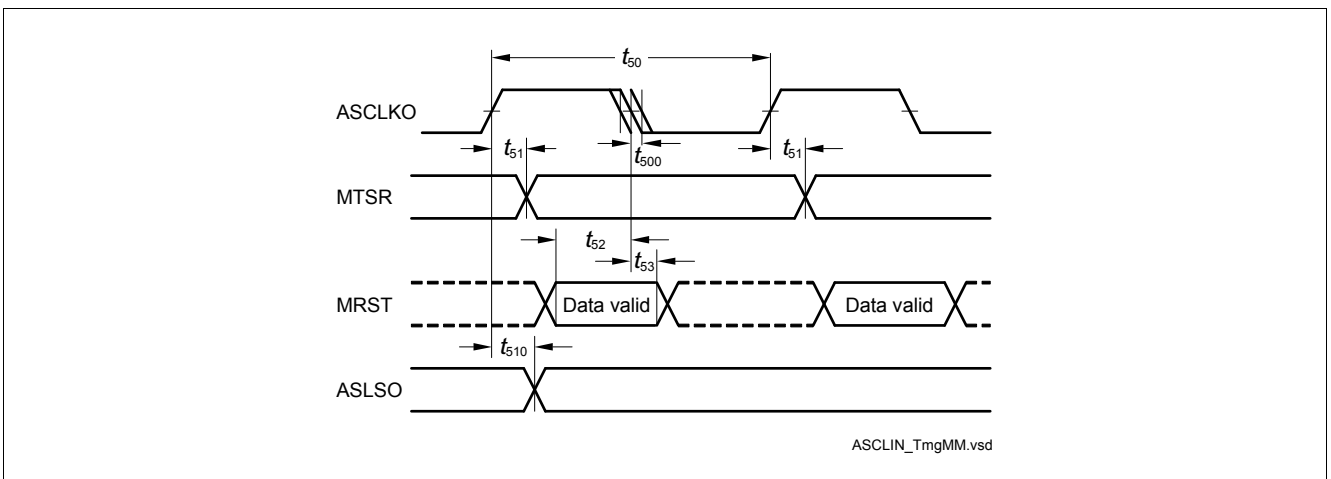

Figure 3-13 ASCLIN SPI Master Timing

3.22 QSPI Timings, Master and Slave Mode

This section defines the timings for the QSPI in the TC37xEXT.

It is assumed that SCLKO, MTSR, and SLSO pads have the same pad settings:

Note: Pad asymmetry is already included in the following timings.

Table 3-44 Master Mode Timing, LVDS output pads for data and clock

Parameter	Symbol	Values			Unit	Note / Test Condition
		Min.	Typ.	Max.		
SCLKO clock period	t_{50} CC	20 ¹⁾	-	-	ns	CL=25pF
Deviation from the ideal duty cycle	t_{500} CC	-1 ¹⁾	-	1 ¹⁾	ns	CL=25pF
MTSR delay from SCLKO shifting edge	t_{51} CC	-3 ¹⁾	-	4 ¹⁾	ns	CL=25pF
SLSOn deviation from the ideal programmed position	t_{510} CC	-4 ¹⁾	-	5.5 ¹⁾	ns	$C_L=25\text{pF}$, driver strength ss
		-10 ¹⁾	-	10 ¹⁾	ns	$C_L=25\text{pF}$, driver strength sm
		-30 ¹⁾	-	30 ¹⁾	ns	$C_L=25\text{pF}$, driver strength m
MRST setup to SCLK latching edge	t_{52} SR	18 ¹⁾	-	-	ns	CL=25pF; valid for LVDS Input pads of QSPI2 only
		19.5 ¹⁾	-	-	ns	CL=25pF; valid for LVDS Input pads of QSPI4 only
MRST hold from SCLK latching edge	t_{53} SR	-1 ¹⁾	-	-	ns	CL=25pF; valid for LVDS Input pads only

1) The load ($C_L=25\text{pF}$) defined in the condition list is a load definition for the single end signal SLSO and does not intend to add an additional load inside the differential signal lines. For single end signals the load definition defines the max length of the signal on the PCB layout. For the LVDS pads the IEEE Std 1596.3-1996 load definitions apply.

Table 3-45 Master Mode Strong Sharp (ss) output pads

Parameter	Symbol	Values			Unit	Note / Test Condition
		Min.	Typ.	Max.		
SCLKO clock period	t_{50} CC	50	-	-	ns	CL=25pF
Deviation from the ideal duty cycle	t_{500} CC	-2	-	2	ns	CL=25pF
MTSR delay from SCLKO shifting edge	t_{51} CC	-4	-	5	ns	CL=25pF
SLSOn deviation from the ideal programmed position	t_{510} CC	-4	-	5	ns	CL=25pF
MRST setup to SCLK latching edge	t_{52} SR	25 ^{1) 2)}	-	-	ns	CL=25pF
MRST hold from SCLK latching edge	t_{53} SR	-2 ^{1) 2)}	-	-	ns	CL=25pF

Electrical Specification QSPI Timings, Master and Slave Mode

- 1) For compensation of the average on-chip delay the QSPI module provides the bit fields ECONz.A, B and C.
- 2) The setup and hold times are valid for both settings of the input pads thresholds: TTL and AL.

Table 3-46 Master Mode Strong Medium (sm) output pads

Parameter	Symbol	Values			Unit	Note / Test Condition
		Min.	Typ.	Max.		
SCLKO clock period	t_{50} CC	50	-	-	ns	CL=50pF
Deviation from the ideal duty cycle	t_{500} CC	-5	-	5	ns	CL=50pF
MTSR delay from SCLKO shifting edge	t_{51} CC	-7	-	7	ns	CL=50pF
SLSON deviation from the ideal programmed position	t_{510} CC	-7	-	7	ns	CL=50pF
MRST setup to SCLK latching edge	t_{52} SR	35 ^{1) 2)}	-	-	ns	CL=50pF
MRST hold from SCLK latching edge	t_{53} SR	-5 ¹⁾²⁾	-	-	ns	CL=50pF

- 1) For compensation of the average on-chip delay the QSPI module provides the bit fields ECONz.A, B and C.
- 2) The setup and hold times are valid for both settings of the input pads thresholds: TTL and AL.

Table 3-47 Master Mode Medium (m) output pads

Parameter	Symbol	Values			Unit	Note / Test Condition
		Min.	Typ.	Max.		
SCLKO clock period	t_{50} CC	160	-	-	ns	CL=50pF
Deviation from the ideal duty cycle	t_{500} CC	-10	-	10	ns	CL=50pF
MTSR delay from SCLKO shifting edge	t_{51} CC	-20	-	20	ns	CL=50pF
SLSON deviation from the ideal programmed position	t_{510} CC	-20	-	20	ns	CL=50pF
MRST setup to SCLK latching edge	t_{52} SR	80 ^{1) 2)}	-	-	ns	CL=50pF
MRST hold from SCLK latching edge	t_{53} SR	-15 ¹⁾²⁾	-	-	ns	CL=50pF
		-13 ¹⁾²⁾	-	-	ns	CL=50pF; SCR SSC

- 1) For compensation of the average on-chip delay the QSPI module provides the bit fields ECONz.A, B and C.
- 2) The setup and hold times are valid for both settings of the input pads thresholds: TTL and AL.

Table 3-48 Slave mode timing

Parameter	Symbol	Values			Unit	Note / Test Condition
		Min.	Typ.	Max.		
SCLK clock period	t_{54} SR	$4 \times T_{MAX}$	-	-	ns	
SCLK duty cycle	t_{55}/t_{54} SR	40	-	60	%	

Electrical Specification QSPI Timings, Master and Slave Mode
Table 3-48 Slave mode timing (cont'd)

Parameter	Symbol	Values			Unit	Note / Test Condition
		Min.	Typ.	Max.		
MTSR setup to SCLK latching edge	t_{56} SR	6	-	-	ns	Input Level AL
		6	-	-	ns	Input Level TTL
MTSR hold from SCLK latching edge	t_{57} SR	4	-	-	ns	Input Level AL
		6	-	-	ns	Input Level TTL
SLSI setup to first SCLK shift edge	t_{58} SR	4	-	-	ns	Input Level AL
		6	-	-	ns	Input Level TTL
SLSI hold from last SCLK latching edge	t_{59} SR	3	-	-	ns	Input Level AL
		6	-	-	ns	Input Level TTL
MRST delay from SCLK shift edge	t_{60} CC	5	-	35	ns	driver = strong edge = medium ; $C_L=50\text{pF}$
		2	-	24	ns	driver = strong edge = sharp ; $C_L=50\text{pF}$
		15	-	80	ns	medium driver ; $C_L=50\text{pF}$
		14	-	-	ns	medium driver ; $C_L=50\text{pF}$; SCR SSC

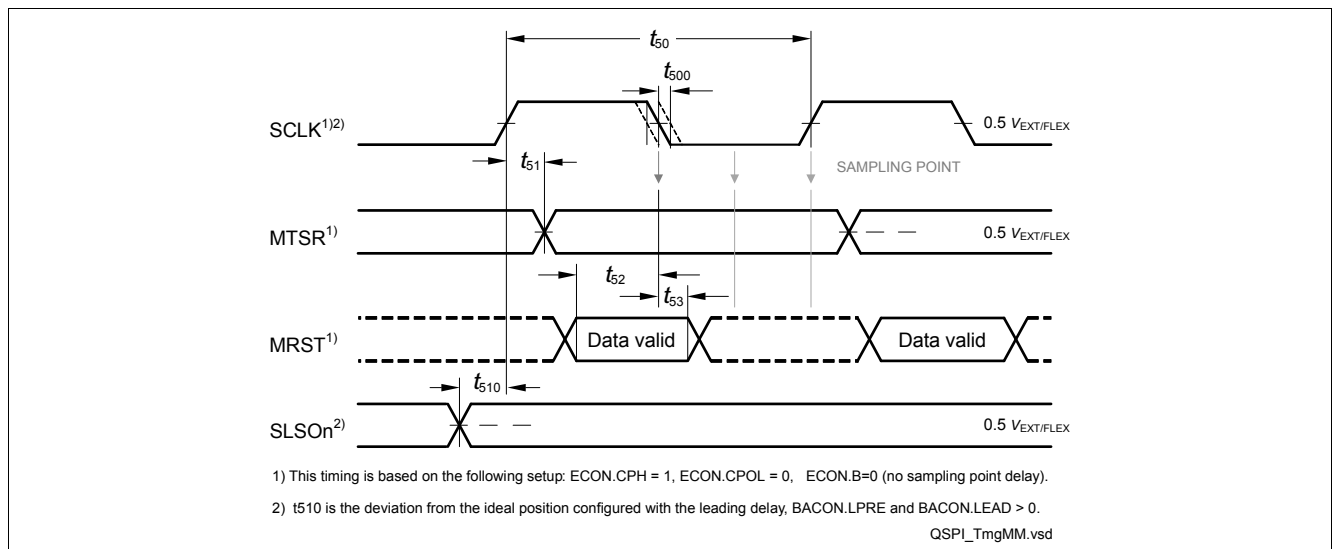
Figure 3-14 Master Mode Timing

Electrical Specification QSPI Timings, Master and Slave Mode

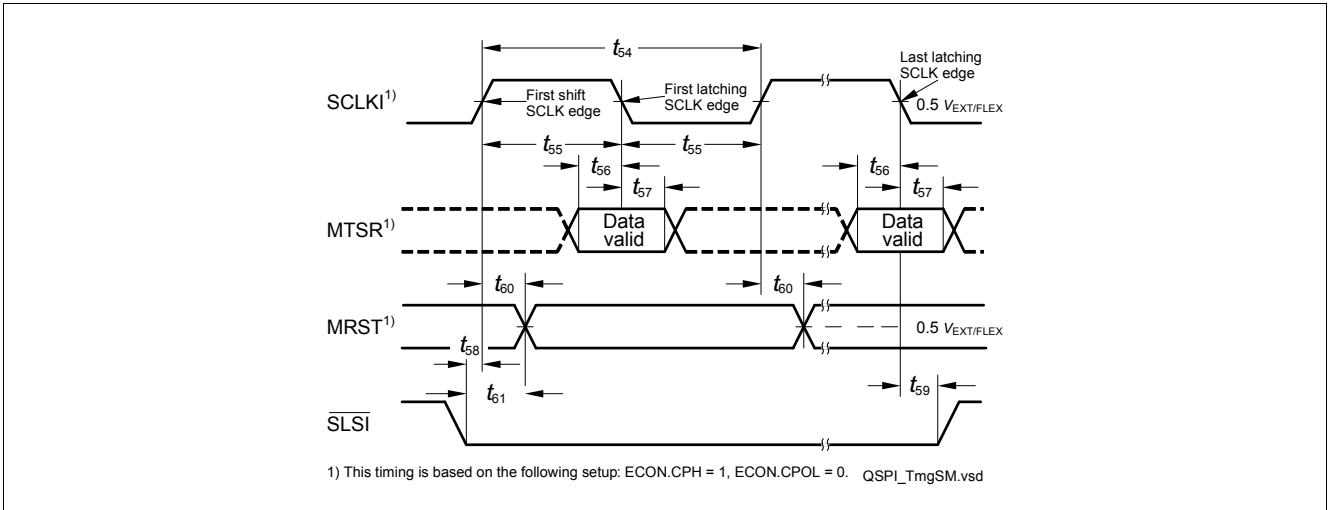

Figure 3-15 Slave Mode Timing

3.23 MSC Timing 5 V Operation

The following section defines the timings.

Note: Pad asymmetry is already included in the following timings.

Note: Load for LVDS pads are defined as differential loads in the following timings.

Table 3-49 LVDS clock/data (LVDS pads in LVDS mode) valid for 5V

Parameter	Symbol	Values			Unit	Note / Test Condition
		Min.	Typ.	Max.		
FCLPx clock period	t_{40} CC	$2 * T_A$ ^{1) 2) 3)}	-	-	ns	LVDS; $C_L=50\text{pF}$
Deviation from ideal duty cycle	t_{400} CC	-1 ³⁾	-	1 ³⁾	ns	LVDS; $0 < C_L < 50\text{pF}$
SOPx output delay	t_{44} CC	-3 ³⁾	-	3 ³⁾	ns	$CL=50\text{pF}$
ENx output delay	t_{45} CC	-4 ³⁾	-	5 ³⁾	ns	ss; $C_L=50\text{pF}$; ABRA block bypassed
		-4 ³⁾	-	4 ³⁾	ns	ss; $C_L=50\text{pF}$; ABRA block used
		-2 ³⁾	-	10 ³⁾	ns	sm; $C_L=50\text{pF}$
		-30 ³⁾	-	30 ³⁾	ns	m; $C_L=50\text{pF}$

1) T_A depends on the clock source selected for baud rate generation in the ABRA block of the MSC.

2) The capacitive load on the LVDS pins is differential, the capacitive load on the CMOS pins is single ended.

3) The load ($C_L=50\text{pF}$) defined in the condition list is a load definition for the single end signal EN and does not intend to add an additional load inside the differential signal lines. For single end signals the load definition defines the max length of the signal on the PCB layout. For the LVDS pads the IEEE Std 1596.3-1996 load definitions apply.

Table 3-50 Strong sharp (ss) driver for clock/data valid for 5V

Parameter	Symbol	Values			Unit	Note / Test Condition
		Min.	Typ.	Max.		
FCLPx clock period	t_{40} CC	$2 * T_A$	-	-	ns	$CL=50\text{pF}$
Deviation from ideal duty cycle	t_{400} CC	-2	-	2	ns	$CL=50\text{pF}$
SOPx output delay	t_{44} CC	-4	-	3.5	ns	$CL=50\text{pF}$
ENx output delay	t_{45} CC	-4	-	3.5	ns	$CL=50\text{pF}$

Table 3-51 Strong medium (sm) driver for clock/data valid for 5V

Parameter	Symbol	Values			Unit	Note / Test Condition
		Min.	Typ.	Max.		
FCLPx clock period	t_{40} CC	$2 * T_A$	-	-	ns	$CL=50\text{pF}$
Deviation from ideal duty cycle	t_{400} CC	-5	-	5	ns	$CL=50\text{pF}$
SOPx output delay	t_{44} CC	-7	-	7	ns	$CL=50\text{pF}$
ENx output delay	t_{45} CC	-7	-	7	ns	$CL=50\text{pF}$

Electrical Specification MSC Timing 5 V Operation

Table 3-52 Medium (m) driver for clock/data valid for 5V

Parameter	Symbol	Values			Unit	Note / Test Condition
		Min.	Typ.	Max.		
FCLPx clock period	t_{40} CC	$2 * T_A$	-	-	ns	CL=50pF
Deviation from ideal duty cycle	t_{400} CC	-10	-	10	ns	CL=50pF
SOPx output delay	t_{44} CC	-20	-	20	ns	CL=50pF
ENx output delay	t_{45} CC	-20	-	20	ns	CL=50pF

Table 3-53 Upstream Interface

Parameter	Symbol	Values			Unit	Note / Test Condition
		Min.	Typ.	Max.		
SDI bit time	t_{46} SR	$8 * t_{MSC}$	-	-	ns	
SDI rise time	t_{48} SR	-	-	200	ns	
SDI fall time	t_{49} SR	-	-	200	ns	

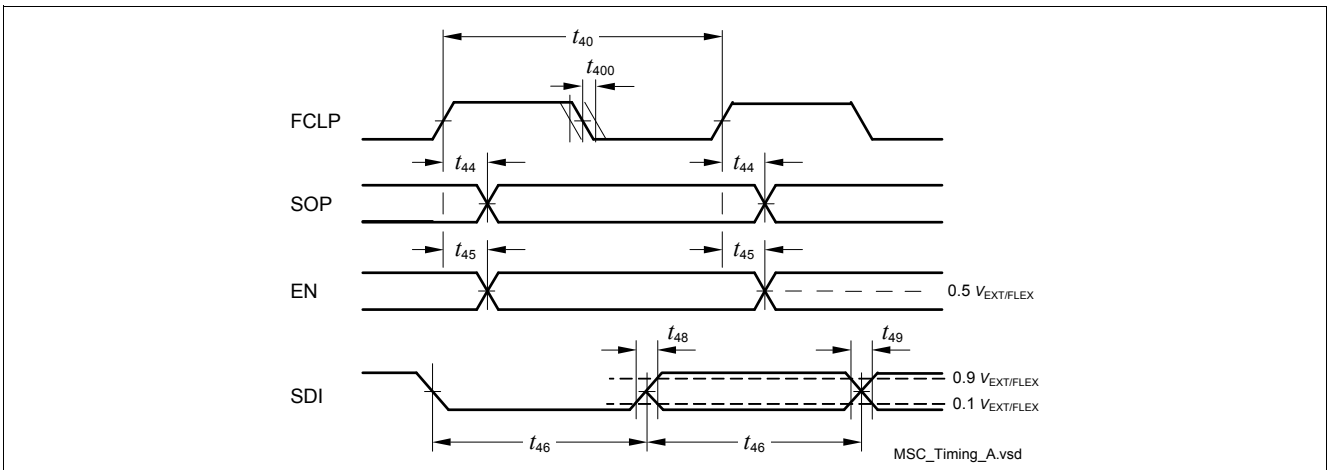

Figure 3-16 MSC Interface Timing

Note: The SOP data signal is sampled with the falling edge of FCLP in the target device.

3.24 Ethernet Interface (ETH) Characteristics

3.24.1 ETH Measurement Reference Points

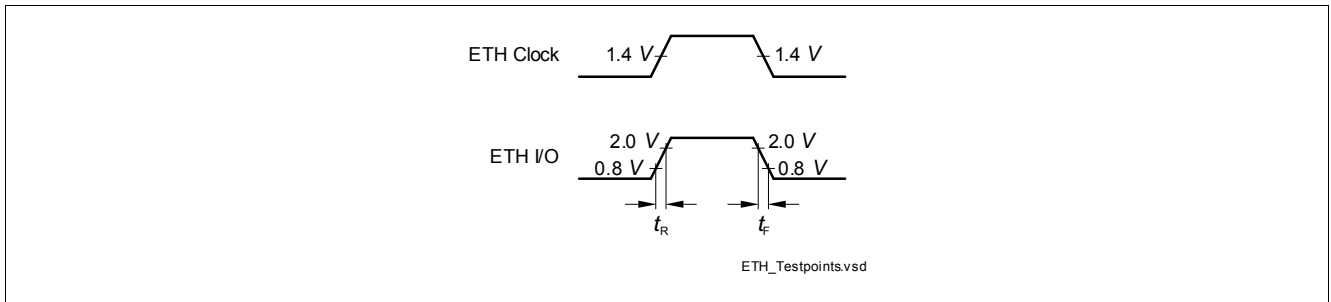

Figure 3-17 ETH Measurement Reference Points

3.24.2 ETH Management Signal Parameters (ETH_MDC, ETH_MDIO)

Table 3-54 ETH Management Signal Parameters valid for 3.3V

Parameter	Symbol	Values			Unit	Note / Test Condition
		Min.	Typ.	Max.		
ETH_MDC period	t_1 CC	400	-	-	ns	CL=25pF
ETH_MDC high time	t_2 CC	160	-	-	ns	CL=25pF
ETH_MDC low time	t_3 CC	160	-	-	ns	CL=25pF
ETH_MDIO setup time (output)	t_4 CC	10	-	-	ns	CL=25pF
ETH_MDIO hold time (output)	t_5 CC	10	-	-	ns	CL=25pF
ETH_MDIO data valid (input)	t_6 SR	0	-	300	ns	CL=25pF

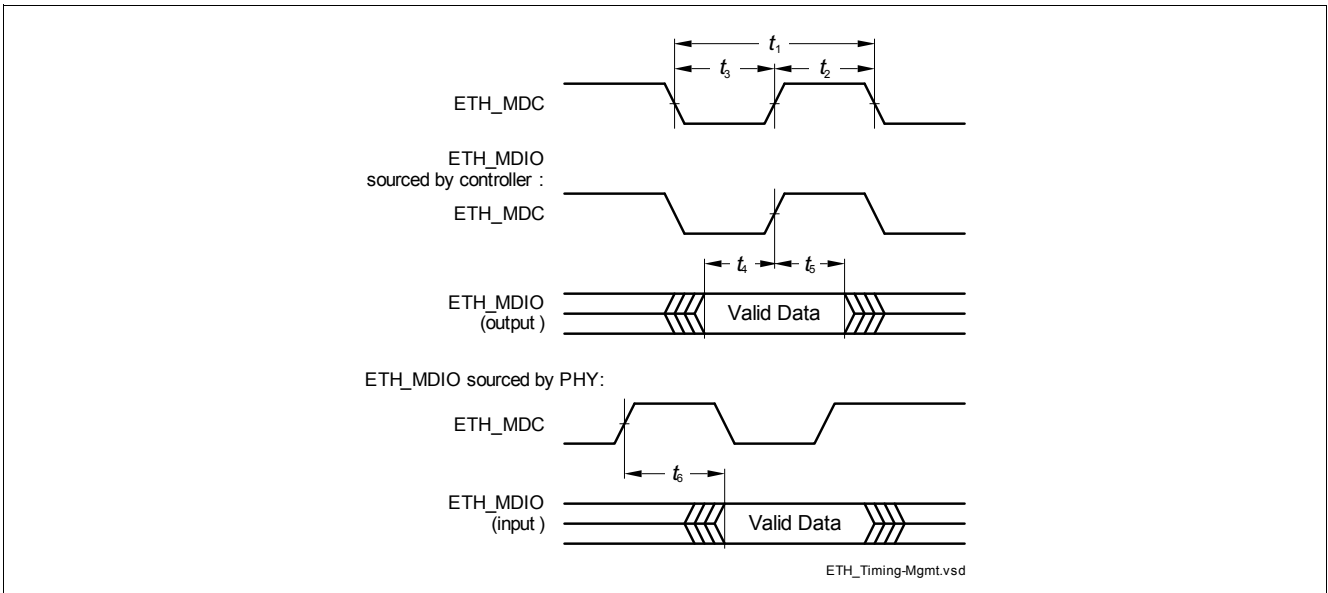

Figure 3-18 ETH Management Signal Timing

Electrical Specification Ethernet Interface (ETH) Characteristics

3.24.3 ETH MII Parameters

In the following, the parameters of the MII (Media Independent Interface) are described.

Table 3-55 ETH MII Signal Timing Parameters

Parameter	Symbol	Values			Unit	Note / Test Condition
		Min.	Typ.	Max.		
Clock period	t_7 SR	40	-	-	ns	CL=25pF ; baudrate=100Mbps
		400	-	-	ns	CL=25pF ; baudrate=10Mbps
Clock high time	t_8 SR	14	-	26	ns	CL=25pF ; baudrate=100Mbps
		140 ¹⁾	-	260 ²⁾	ns	CL=25pF ; baudrate=10Mbps
Clock low time	t_9 SR	14	-	26	ns	CL=25pF ; baudrate=100Mbps
		140 ¹⁾	-	260 ²⁾	ns	CL=25pF ; baudrate=10Mbps
Input setup time	t_{10} SR	10	-	-	ns	CL=25pF
Input hold time	t_{11} SR	10	-	-	ns	CL=25pF
Output valid time	t_{12} CC	0	-	25	ns	CL=25pF

- 1) Defined by 35% of clock period.
- 2) Defined by 65% of clock period.

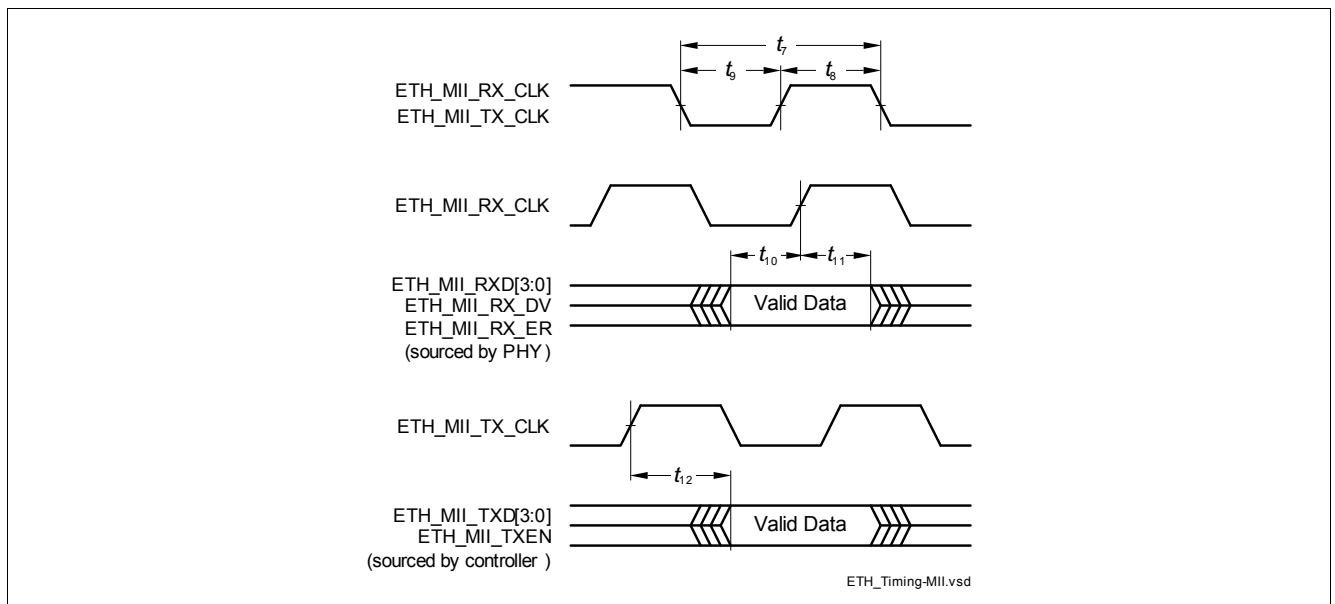

Figure 3-19 ETH MII Signal Timing

3.24.4 ETH RMII Parameters

In the following, the parameters of the RMII (Reduced Media Independent Interface) are described.

Table 3-56 ETH RMII Signal Timing Parameters valid for 3.3V

Parameter	Symbol	Values			Unit	Note / Test Condition
		Min.	Typ.	Max.		
ETH_RMII_REF_CL clock period	t_{13} CC	20	-	-	ns	50ppm ; CL=25pF
ETH_RMII_REF_CL clock high time	t_{14} CC	7 ¹⁾	-	13 ²⁾	ns	CL=25pF
ETH_RMII_REF_CL clock low time	t_{15} CC	7 ¹⁾	-	13 ²⁾	ns	CL=25pF
ETHTXEN, ETHTXD[1:0], ETHRXD[1:0], ETHCRSDV; setup time	t_{16} CC	4	-	-	ns	CL=25pF
ETHTXEN, ETHTXD[1:0], ETHRXD[1:0], ETHCRSDV; hold time	t_{17} CC	2	-	-	ns	CL=25pF

1) Defined by 35% of clock period.

2) Defined by 65% of clock period.

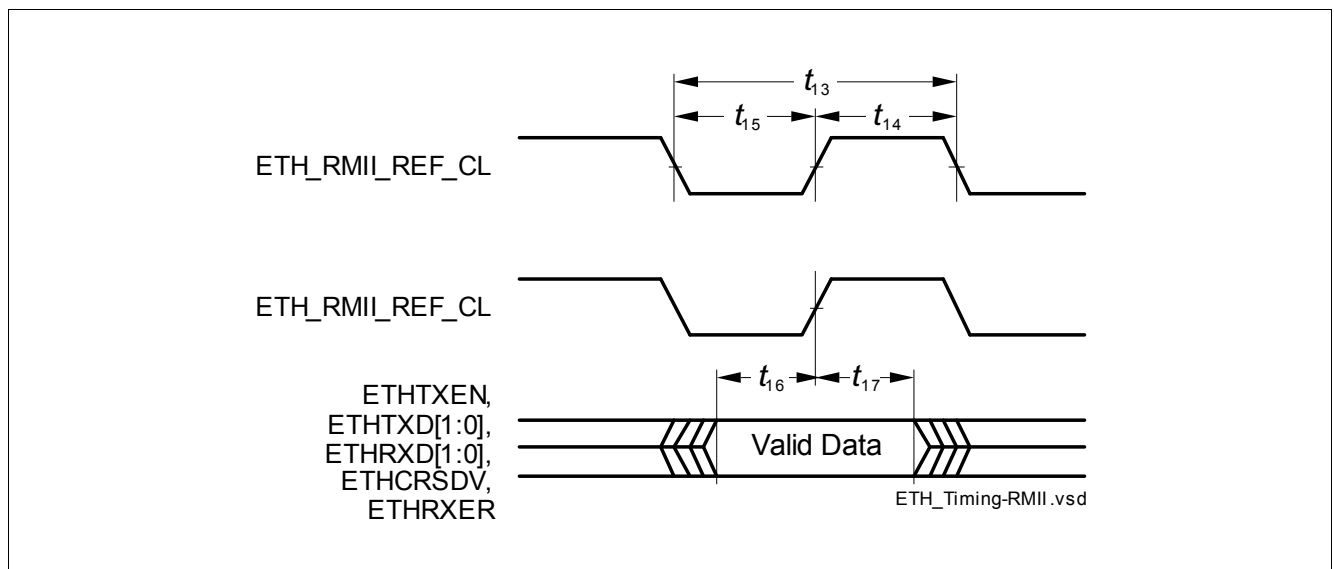

Figure 3-20 ETH RMII Signal Timing

Electrical Specification Ethernet Interface (ETH) Characteristics

3.24.5 ETH RGMII Parameters

In the following, the parameters of the RGMII are described.

Table 3-57 ETH RGMII Signal Timing Parameters valid for 3.3V

Parameter	Symbol	Values			Unit	Note / Test Condition
		Min.	Typ.	Max.		
TX Clock period	t_{19} CC	36	40	44	ns	100Mbps
		360	400	440	ns	10Mbps
		7.2	8	8.8	ns	Gigabit
Data to Clock Output skew	t_{20} CC	-500	0	500	ps	
Data to Clock input skew (at receiver)	t_{21} SR	1	1.8	2.6	ns	SKEWCTL.RXCFG = 0; SKEWCTL.TXCFG = 0
Clock duty cycle	t_{duty} CC	40	50	60	%	10/100Mbps
		45	50	55	%	Gigabit
GREFCLK duty cycle	t_{duty_in} SR	45	-	55	%	
GREFCLK Input accuracy	ACC SR	-0.005	-	0.005	%	

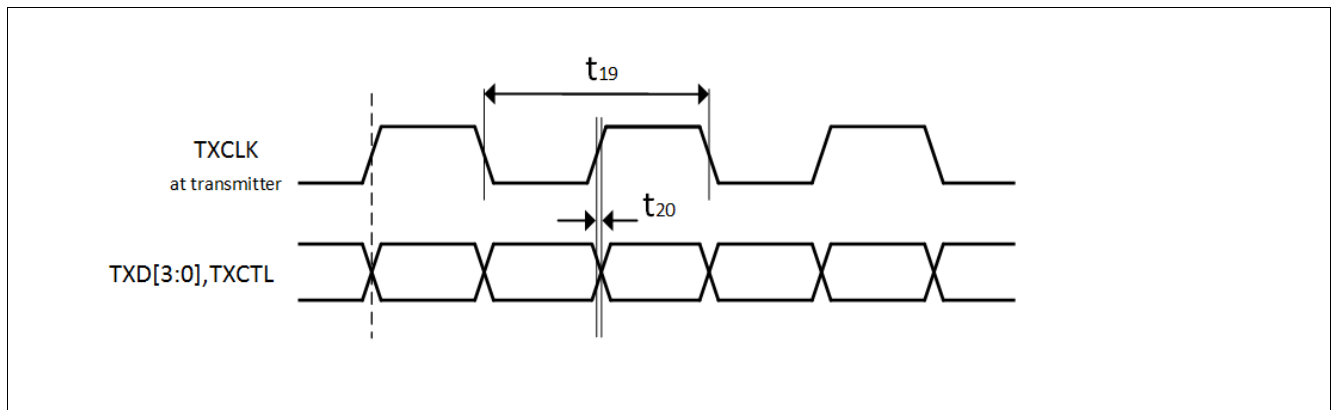

Figure 3-21 ETH RGMII TX Signal Timing (Delay on Destination (DoD))

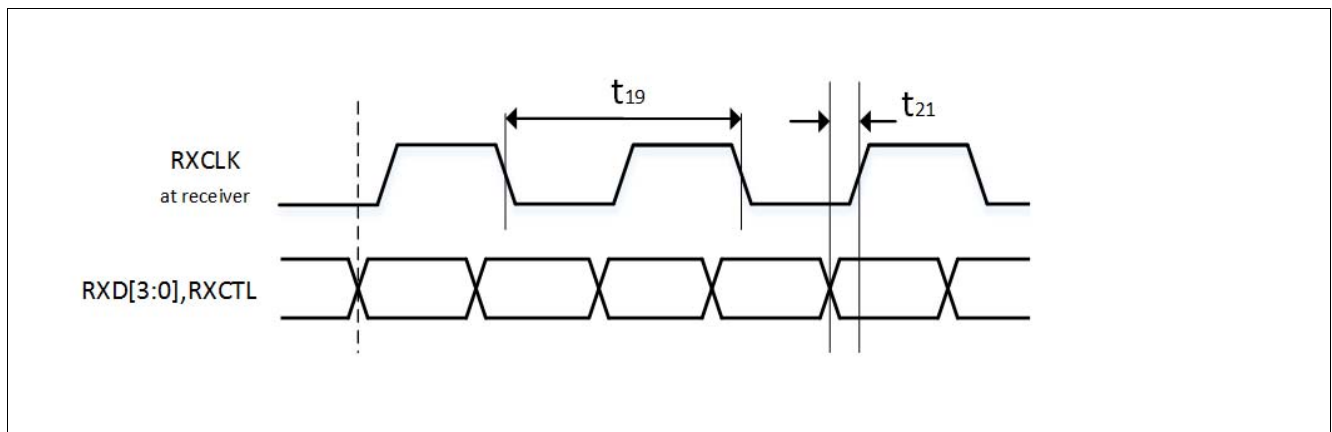

Figure 3-22 ETH RGMII RX Signal Timing (Delay on Source (DoS))

3.25 E-Ray Parameters

The timings of this section are valid for the strong driver and sharp edge settings of the output drivers with $C_L = 25$ pF.

Table 3-58 Transmit Parameters

Parameter	Symbol	Values			Unit	Note / Test Condition
		Min.	Typ.	Max.		
Rise time of TxEN	$t_{dCCTxENRise25CC}$	-	-	9	ns	$C_L=25pF$
Fall time of TxEN	$t_{dCCTxENFall25CC}$	-	-	9	ns	$C_L=25pF$
Sum of rise and fall time	$t_{dCCTxRise25+dCCTxFall25CC}$	-	-	9	ns	20% - 80% ; $C_L=25pF$
Sum of delay between TP1_FF and TP1_CC and delays derived from TP1_FFi, rising edge of TxEN	$t_{dCCTxEN01CC}$	-	-	25	ns	
Sum of delay between TP1_FF and TP1_CC and delays derived from TP1_FFi, falling edge of TxEN	$t_{dCCTxEN10CC}$	-	-	25	ns	
Asymmetry of sending	$t_{tx_asym} CC$	-2.45	-	2.45	ns	$C_L=25pF$
Sum of delay between TP1_FF and TP1_CC and delays derived from TP1_FFi, rising edge of TxD	$t_{dCCTxD01CC}$	-	-	25	ns	
Sum of delay between TP1_FF and TP1_CC and delays derived from TP1_FFi, falling edge of TxD	$t_{dCCTxD10CC}$	-	-	25	ns	
TxD signal sum of rise and fall time at TP1_BD	$t_{txd_sum} CC$	-	-	9	ns	

Table 3-59 Receive Parameters

Parameter	Symbol	Values			Unit	Note / Test Condition
		Min.	Typ.	Max.		
Acceptance of asymmetry at receiving part	$t_{dCCTxAsymAccept25} SR$	-30.5	-	43.0	ns	$C_L=25pF$
Acceptance of asymmetry at receiving part	$t_{dCCTxAsymAccept15} SR$	-31.5	-	44.0	ns	$C_L=15pF$
Threshold for detecting logical high	$T_{uCCLogic1} SR$	35	-	70	%	
Threshold for detecting logical low	$T_{uCCLogic0} SR$	30	-	65	%	

Electrical Specification E-Ray Parameters

Table 3-59 Receive Parameters (cont'd)

Parameter	Symbol	Values			Unit	Note / Test Condition
		Min.	Typ.	Max.		
Sum of delay between TP4_CC and TP4_FF and delays derived from TP4_FFi, rising edge of RxD	$t_{dCCRxD01}$ CC	-	-	10	ns	
Sum of delay between TP4_CC and TP4_FF and delays derived from TP4_FFi, falling edge of RxD	$t_{dCCRxD10}$ CC	-	-	10	ns	

3.26 HSCT Parameters

Table 3-60 HSCT - Rx parasitics and loads

Parameter	Symbol	Values			Unit	Note / Test Condition
		Min.	Typ.	Max.		
Capacitance total budget	C_{total} CC	-	3.5	5	pF	Total Budget for complete receiver including silicon, package, pins and bond wire
Parasitic inductance budget	H_{total} CC	-	5	-	nH	

Table 3-61 HSCT - Rx/Tx setup timing

Parameter	Symbol	Values			Unit	Note / Test Condition
		Min.	Typ.	Max.		
RX o/p duty cycle	DC_{rx} CC	40	-	60	%	
Disable time of the LVDS pad	$t_{LVDS_{DIS}}$ CC	-	-	20	ns	
Enable time of the LVDS pad	$t_{LVDS_{SEN}}$ CC	-	-	400	ns	
Wakeup time from Sleep Mode	t_{SWU} CC	-	-	250	ns	
Maximum length of a wake-up glitch that does not wake-up the receiver	t_{WUP} CC	-	-	0.2	ns	
Bias startup time	t_{bias} CC	-	5	10	μ s	Bias distributor waking up from power down and provide stable Bias.
RX startup time	t_{rx} CC	-	-	600	ns	Wake-up RX from power down.
TX startup time	t_{tx} CC	-	-	280	ns	Wake-up TX from power down.

3.27 Inter-IC (I2C) Interface Timing

This section defines the timings for I2C in the TC37xEXT.

All I2C timing parameter are SR for Master Mode and CC for Slave Mode.

Table 3-62 I2C Standard Mode Timing

Parameter	Symbol	Values			Unit	Note / Test Condition
		Min.	Typ.	Max.		
Fall time of both SDA and SCL	t_1	-	-	300	ns	Measured with a pull-up resistor of 4.7 kohms at each of the SCL and SDA line
Capacitive load for each bus line	C_b SR	-	-	400	pF	
Bus free time between a STOP and ATART condition	t_{10}	4.7	-	-	μ s	Measured with a pull-up resistor of 4.7 kohms at each of the SCL and SDA line
Rise time of both SDA and SCL	t_2	-	-	1000	ns	Measured with a pull-up resistor of 4.7 kohms at each of the SCL and SDA line
Data hold time	t_3	0	-	-	μ s	Measured with a pull-up resistor of 4.7 kohms at each of the SCL and SDA line
Data set-up time	t_4	250	-	-	ns	Measured with a pull-up resistor of 4.7 kohms at each of the SCL and SDA line
Low period of SCL clock	t_5	4.7	-	-	μ s	Measured with a pull-up resistor of 4.7 kohms at each of the SCL and SDA line
High period of SCL clock	t_6	4	-	-	μ s	Measured with a pull-up resistor of 4.7 kohms at each of the SCL and SDA line
Hold time for the (repeated) START condition	t_7	4	-	-	μ s	Measured with a pull-up resistor of 4.7 kohms at each of the SCL and SDA line

Electrical Specification Inter-IC (I2C) Interface Timing
Table 3-62 I2C Standard Mode Timing (cont'd)

Parameter	Symbol	Values			Unit	Note / Test Condition
		Min.	Typ.	Max.		
Set-up time for (repeated) START condition	t_8	4.7	-	-	μs	Measured with a pull-up resistor of 4.7 kohms at each of the SCL and SDA line
Set-up time for STOP condition	t_9	4	-	-	μs	Measured with a pull-up resistor of 4.7 kohms at each of the SCL and SDA line

Table 3-63 I2C Fast Mode Timing

Parameter	Symbol	Values			Unit	Note / Test Condition
		Min.	Typ.	Max.		
Fall time of both SDA and SCL	t_1	$20+0.1 \cdot C_b$	-	300	ns	Measured with a pull-up resistor of 4.7 kohms at each of the SCL and SDA line
Capacitive load for each bus line	C_b SR	-	-	400	pF	
Bus free time between a STOP and ATART condition	t_{10}	1.3	-	-	μs	Measured with a pull-up resistor of 4.7 kohms at each of the SCL and SDA line
Rise time of both SDA and SCL	t_2	$20+0.1 \cdot C_b$	-	300	ns	Measured with a pull-up resistor of 4.7 kohms at each of the SCL and SDA line
Data hold time	t_3	0	-	-	μs	Measured with a pull-up resistor of 4.7 kohms at each of the SCL and SDA line
Data set-up time	t_4	100	-	-	ns	Measured with a pull-up resistor of 4.7 kohms at each of the SCL and SDA line
Low period of SCL clock	t_5	1.3	-	-	μs	Measured with a pull-up resistor of 4.7 kohms at each of the SCL and SDA line
High period of SCL clock	t_6	0.6	-	-	μs	Measured with a pull-up resistor of 4.7 kohms at each of the SCL and SDA line

Electrical Specification Inter-IC (I2C) Interface Timing
Table 3-63 I2C Fast Mode Timing (cont'd)

Parameter	Symbol	Values			Unit	Note / Test Condition
		Min.	Typ.	Max.		
Hold time for the (repeated) START condition	t_7	0.6	-	-	μs	Measured with a pull-up resistor of 4.7 kohms at each of the SCL and SDA line
Set-up time for (repeated) START condition	t_8	0.6	-	-	μs	Measured with a pull-up resistor of 4.7 kohms at each of the SCL and SDA line
Set-up time for STOP condition	t_9	0.6	-	-	μs	Measured with a pull-up resistor of 4.7 kohms at each of the SCL and SDA line

Table 3-64 I2C High Speed Mode Timing

Parameter	Symbol	Values			Unit	Note / Test Condition
		Min.	Typ.	Max.		
Capacitive load for each bus line	C_b SR	-	-	400	pF	
Fall time of SCL	t_{11}	10 ¹⁾	-	40 ¹⁾	ns	bus line load of 100pF
Fall time of SDA	t_{12}	10 ¹⁾	-	80 ¹⁾	ns	bus line load of 100pF
Rise time of SCL	t_{13}	10 ¹⁾	-	40 ¹⁾	ns	bus line load of 100pF
Rise time of SDA	t_{14}	10 ¹⁾	-	80 ¹⁾	ns	bus line load of 100pF
Data hold time	t_3	0 ¹⁾	-	70 ¹⁾	ns	bus line load of 100pF
Data set-up time	t_4	10 ¹⁾	-	-	ns	bus line load of 100pF
Low period of SCL clock	t_5	160 ¹⁾	-	-	ns	bus line load of 100pF
High period of SCL clock	t_6	60 ¹⁾	-	-	ns	bus line load of 100pF
Hold time for the (repeated) START condition	t_7	160 ¹⁾	-	-	ns	bus line load of 100pF
Set-up time for (repeated) START condition	t_8	160 ¹⁾	-	-	ns	bus line load of 100pF
Set-up time for STOP condition	t_9	160 ¹⁾	-	-	ns	bus line load of 100pF

1) Values are defined for $C_b = 100\text{pF}$, for the Timing of $C_b = 400\text{pF}$ see the I2C Standard.

Electrical Specification Inter-IC (I2C) Interface Timing

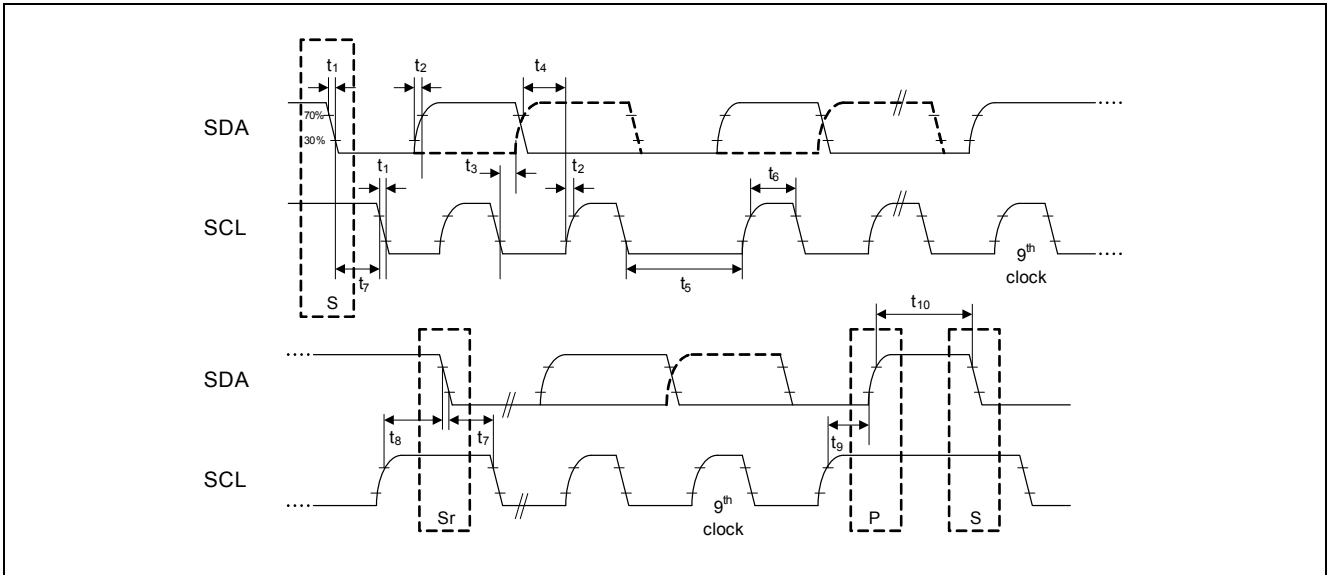
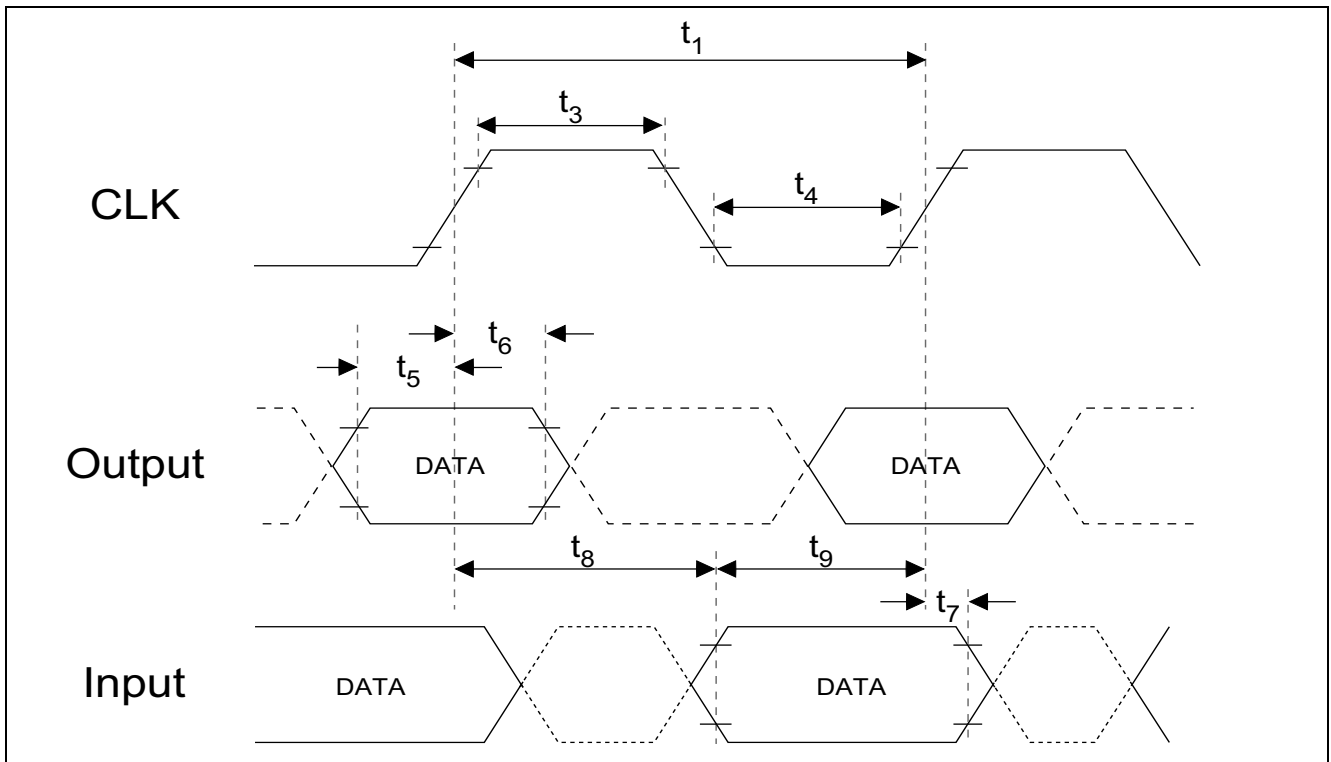

Figure 3-23 I2C Standard and Fast Mode Timing

3.28 SDMMC Interface Timing
Table 3-65 SDMMC

Parameter	Symbol	Values			Unit	Note / Test Condition
		Min.	Typ.	Max.		
Clock period Data Transfer Mode	t_1 CC	20	-	-	ns	push-pull, $C_L \leq 30\text{pF}$, $V_{EXT} = 3.3\text{V}$
Clock period Identification Mode	t_2 CC	-	-	2500	ns	open-drain, $C_L \leq 30\text{pF}$, $V_{EXT} = 3.3\text{V}$
Clock low time	t_3 CC	6,5	-	-	ns	$C_L \leq 30\text{pF}$, $V_{EXT} = 3.3\text{V}$
Clock high time	t_4 CC	6,5	-	-	ns	$C_L \leq 30\text{pF}$, $V_{EXT} = 3.3\text{V}$
Data output valid time before rising clock edge	t_5 CC	3	-	-	ns	$C_L \leq 30\text{pF}$, $V_{EXT} = 3.3\text{V}$
Data output valid time after rising clock edge	t_6 CC	3	-	-	ns	$C_L \leq 30\text{pF}$, $V_{EXT} = 3.3\text{V}$
Data input hold time	t_7 SR	2,5	-	-	ns	$C_L \leq 30\text{pF}$, $V_{EXT} = 3.3\text{V}$, TTL levels
Data Input delay time	t_8 SR	-	-	13,7	ns	$C_L \leq 30\text{pF}$, $V_{EXT} = 3.3\text{V}$, TTL levels
Data Input setup time	t_9 SR	5,2	-	-	ns	$C_L \leq 30\text{pF}$, $V_{EXT} = 3.3\text{V}$, TTL levels

Figure 3-24 SDMMC Timing

3.29 Camera Interface Timing (CIF)
Table 3-66 Timings for 3.3V±10% pad power supply

Parameter	Symbol	Values			Unit	Note / Test Condition
		Min.	Typ.	Max.		
Pixel clock period	t_{70} SR	10.42	-	-	ns	
HSYNC, VSYNC set up time	t_{71} SR	2.5	-	-	ns	CIF input level
		2.5	-	-	ns	AL input level
HSYNC, VSYNC hold time	t_{72} SR	2.5	-	-	ns	CIF input level
		2.5	-	-	ns	AL input level
Pixel data set up time	t_{73} SR	2.5	-	-	ns	AL input level
		2.5	-	-	ns	CIF input level
Pixel data hold time	t_{74} SR	2.5	-	-	ns	CIF input level
		2.5	-	-	ns	AL input level

Table 3-67 Timings for 0.4V to 2.4V input signals (2.8V imager)

Parameter	Symbol	Values			Unit	Note / Test Condition
		Min.	Typ.	Max.		
Pixel clock period	t_{70} SR	12.5	-	-	ns	
HSYNC, VSYNC set up time	t_{71} SR	3	-	-	ns	CIF Input Levels, 3.3V±10%
HSYNC, VSYNC hold time	t_{72} SR	3	-	-	ns	CIF Input Levels, 3.3V±10%
Pixel data set up time	t_{73} SR	3	-	-	ns	CIF Input Levels, 3.3V±10%
Pixel data hold time	t_{74} SR	3	-	-	ns	CIF Input Levels, 3.3V±10%

Table 3-68 Timings for 1.8V imager, CIF input level

Parameter	Symbol	Values			Unit	Note / Test Condition
		Min.	Typ.	Max.		
Pixel clock period	t_{70} SR	10.42	-	-	ns	
HSYNC, VSYNC set up time	t_{71} SR	2	-	-	ns	Input signal 0.4V to 1.4V
HSYNC, VSYNC hold time	t_{72} SR	2	-	-	ns	Input signal 0.4V to 1.4V
Pixel data set up time	t_{73} SR	2	-	-	ns	Input signal 0.4V to 1.4V
Pixel data hold time	t_{74} SR	2	-	-	ns	Input signal 0.4V to 1.4V

3.30 Flash Target Parameters
Table 3-69 Flash

Parameter	Symbol	Values			Unit	Note / Test Condition
		Min.	Typ.	Max.		
Program Flash Erase Time per logical sector ¹⁾	t_{ERP} CC	-	-	0.5	s	cycle count < 1000
Program Flash Erase Time per Multi-Sector Command ¹⁾	t_{MERP} CC	-	-	0.5	s	For consecutive logical sectors in a physical sector with total range ≤ 512 kByte; cycle count < 1000
Program Flash program time per page in 5 V mode ¹⁾	t_{PRP5} CC	-	-	80	μs	32 Byte
Program Flash program time per page in 3.3 V mode ¹⁾	t_{PRP3} CC	-	-	115	μs	32 Byte
Program Flash program time per burst in 5 V mode ¹⁾	t_{PRPB5} CC	-	-	220	μs	256 Byte
Program Flash program time per burst in 3.3 V mode ¹⁾	t_{PRPB3} CC	-	-	530	μs	256 Byte
Program Flash program time for 1 MByte with burst programming in 3.3 V mode excluding communication ¹⁾	t_{PRPB3_1MB} CC	-	-	2.2	s	Derived value for documentation purpose
Program Flash program time for 1 MByte with burst programming in 5 V mode excluding communication ¹⁾	t_{PRPB5_1MB} CC	-	-	1	s	Derived value for documentation purpose
Program Flash program time for complete PFlash with burst programming in 5 V mode excluding communication ¹⁾	t_{PRPB5_PF} CC	-	-	6	s	Derived value for documentation purpose
Write Page Once adder ¹⁾	t_{ADD} CC	-	-	20	μs	Adder to Program Time when using Write Page Once
Program Flash suspend to read latency ¹⁾	t_{SPNDP} CC	-	-	120	μs	For Write Burst, Verify Erased and for multi-(logical) sector erase commands
Data Flash Erase Disturb Limit (single ended sensing mode)	N_{DFD} CC	-	-	50	cycles	
Data Flash Erase Disturb Limit (complement sensing mode)	N_{DFDC} CC	-	-	500	cycles	
UCB Erase Disturb Limit	N_{UCBD} CC	-	-	500	cycles	

Electrical Specification Flash Target Parameters
Table 3-69 Flash (cont'd)

Parameter	Symbol	Values			Unit	Note / Test Condition
		Min.	Typ.	Max.		
Program time data flash per page ¹⁾²⁾	t_{PRD} CC	-	-	75	μ s	8 Byte
Complete Device Flash Erase Time PFlash and DFlash ^{1)3) 4) 5)}	t_{ER_Dev} CC	-	4.3	7	s	Valid for less than 1000 cycles, w/o UCB. Derived value for documentation purpose.
Data Flash program time per burst ¹⁾²⁾	t_{PRDB} CC	-	-	140	μ s	32 Byte
Data Flash suspend to read latency ¹⁾	t_{SPNDD} CC	-	-	120	μ s	
Wait time after margin change	$t_{FL_MarginDel}$ CC	-	-	2	μ s	
Program Flash Endurance per Logical Sector	N_{E_P} CC	-	-	1000	cycles	Replace logical sector command shall be used if a sector fails during erase or program
Number of erase operations per physical sector in program flash	N_{ERP} CC	-	-	16000	cycles	
Program Flash Retention Time, Sector	t_{RET} CC	20	-	-	years	Max. 1000 erase/program cycles
UCB Retention Time	t_{RTU} CC	20	-	-	years	Max. 100 erase/program cycles per UCB, max 500 erase/program cycles for all UCBs together
Data Flash access delay	t_{DF} CC	-	-	100	ns	see RFLASH of DMU register HF_DWAIT
Data Flash ECC Delay	t_{DFECC} CC	-	-	20	ns	see RECC of DMU register HF_DWAIT
Program Flash access delay	t_{PF} CC	-	-	30	ns	see RFLASH of DMU register HF_PWAIT
Program Flash ECC delay	t_{PFECC} CC	-	-	10	ns	see RECC and CECC of DMU register HF_PWAIT
Number of erase operations on DF0 over lifetime (complement sensing mode) ⁶⁾	N_{ERD0C} CC	-	-	4000000	cycles	
Number of erase operations on DF0 over lifetime (single ended sensing mode) ⁷⁾	N_{ERD0S} CC	-	-	750000	cycles	

Electrical Specification Flash Target Parameters
Table 3-69 Flash (cont'd)

Parameter	Symbol	Values			Unit	Note / Test Condition
		Min.	Typ.	Max.		
Number of erase operations on DF1 over lifetime (complement sensing mode) ⁶⁾	N_{ERD1C} CC	-	-	2000000	cycles	
Number of erase operations on DF1 over lifetime (single ended sensing mode) ⁷⁾	N_{ERD1S} CC	-	-	500000	cycles	
Data Flash Endurance per EEPROMx sector (complement sensing mode) ⁸⁾	N_{E_EEP10C} CC	-	-	500000	cycles	Max. data retention time 10 years
DataFlash Endurance per EEPROMx sector (single ended sensing mode) ⁸⁾	N_{E_EEP10S} CC	-	-	125000	cycles	Retention time and Tj according below example temperature profile
		-	-	125000	cycles	max data retention time 20y, Tj=110°C
		-	-	125000	cycles	max data retention time 8.2y, Tj=125°C
Data Flash Endurance per HSMx sector (complement sensing mode) ⁸⁾	N_{E_HSMC} CC	-	-	250000	cycles	Max. data retention time 10 years
Data Flash Endurance per HSMx sector (single ended sensing mode) ⁸⁾	N_{E_HSMs} CC	-	-	125000	cycles	Retention time and Tj according below example temperature profile
		-	-	125000	cycles	max data retention time 20y, Tj=110°C
		-	-	125000	cycles	max data retention time 8.2y, Tj=125°C
Junction temperature limit for PFlash program/erase operations	$T_{JPFlash}$ SR	-	-	150	°C	
Data Flash Erase Time per Sector ¹⁾³⁾⁵⁾	t_{ERD1} CC	-	-	0.5	s	Max. 1000 erase/program cycles
Data Flash Erase Time per Sector ¹⁾³⁾⁵⁾	t_{ERDM} CC	-	-	1.5	s	Max allowed cycles, see NE_EEP10 and NE_HSM parameters
DataFlash Adder on Erase Time per 32kByte erase size when using complement sensing mode ¹⁾	$t_{ER_ADDC32C}$ CC	-	-	50	ms	Adder per 32 kByte on erase time; applicable only when using complement mode

Electrical Specification Flash Target Parameters
Table 3-69 Flash (cont'd)

Parameter	Symbol	Values			Unit	Note / Test Condition
		Min.	Typ.	Max.		
Data Flash Erase Time per Multi-Sector Command ¹⁾³⁾⁵⁾	t_{MERD1} CC	-	-	0.5	s	Max 1000 erase/program cycles; For consecutive logical sectors ≤ 256 KBytes
Data Flash Erase Time per Multi-Sector Command ¹⁾³⁾⁵⁾	t_{MERDM} CC	-	-	1.5	s	Max allowed cycles, see NE_EEP10x and NE_HSMx Parameters; For consecutive logical sectors ≤ 256 kByte
Program Flash Access Delay at reduced VDDP3 voltage supply during cranking	$t_{PF_low_VDDP3}$ CC	-	-	60	ns	see register DMU_HF_PWAIT.CFLASH
Data Flash Erase Verify time per page (Complement Sensing) ²⁾	$t_{VER_PAGE_D}$ C CC	-	-	10	μ s	Time per 8 Byte page for Verify Erased Page command
Data Flash Erase Verify time per page (Single Ended Sensing) ¹⁾	$t_{VER_PAGE_D}$ S CC	-	-	10	μ s	Time per 8 Byte page for Verify Erased Page command
Program Flash Erase Verify time per page ¹⁾	$t_{VER_PAGE_P}$ CC	-	-	10	μ s	Time per 32 Byte page for Verify Erased Page command
Data Flash Erase Verify time per sector (Complement Sensing) ¹⁾	$t_{VER_SEC_DC}$ CC	-	-	200	μ s	Time per 2 KB sector for Verify Erased Logical Sector Range command
Data Flash Erase Verify time per sector (Single Ended Sensing) ¹⁾	$t_{VER_SEC_DS}$ CC	-	-	360	μ s	Time per 4 KB sector for Verify Erased Logical Sector Range command
Program Flash Erase Verify time per sector ¹⁾	$t_{VER_SEC_P}$ CC	-	-	360	μ s	Time per 16KB sector for Verify Erased Logical Sector Range command
Data Flash Erase Verify time per wordline (Complement Sensing) ¹⁾	$t_{VER_WL_DC}$ CC	-	-	30	μ s	
Data Flash Erase Verify time per wordline (Single Ended Sensing) ¹⁾	$t_{VER_WL_DS}$ CC	-	-	50	μ s	
Program Flash Erase Verify time per wordline ¹⁾	$t_{VER_WL_P}$ CC	-	-	30	μ s	

1) Only valid for $f_{FSI} = 100$ MHz.

2) Time is not dependent on program mode (5V or 3.3V).

Electrical Specification Flash Target Parameters

- 3) Under out-of-spec conditions (e.g. over-cycling) or in case of activation of WL oriented defects, the duration of erase processes may be increased by up to 50%.
- 4) Using 512 kByte / 256 kByte erase commands (PFlash / DFlash).
- 5) If the DataFlash is operated in Complement Sensing Mode the erase time is increased by $\text{erase_size} / 32\text{kByte} \times t_{\text{ER_ADDC32C}}$
- 6) Allows segmentation of addressable memory into 8 logical sectors; round robin cycling must still be done to consider erase disturb limit N_{DFD} .
- 7) Allows segmentation of addressable memory into 6 logical sectors; round robin cycling must still be done to consider erase disturb limit N_{DFD} .
- 8) Only valid when a robust EEPROM emulation algorithm is used. For more details see the Users Manual.

3.31 Quality Declarations

Table 3-70 Quality Parameters

Parameter	Symbol	Values			Unit	Note / Test Condition
		Min.	Typ.	Max.		
Moisture Sensitivity Level	MSL CC	-	-	3		Conforming to Jedec J-STD--020C for 240C
ESD susceptibility according to Charged Device Model (CDM)	V_{CDM} SR	-	-	500 ¹⁾	V	for all other balls/pins; conforming to JESD22-C101-C
		-	-	750	V	for corner balls/pins; conforming to JESD22-C101-C
ESD susceptibility according to Human Body Model (HBM)	V_{HBM} SR	-	-	2000 ²⁾	V	Conforming to JESD22-A114-B
ESD susceptibility of the LVDS pins according to Human Body Model (HBM)	V_{HBM1} SR	-	-	2000	V	
Operation Lifetime	t_{OP} CC	-	-	24500	hour	see below temperature profile as an example

1) Pads of the AGBT interface are limited to a maximum value of 250V.

2) Pads of the AGBT interface are limited to a maximum value of 1000V.

Example Temperature Profile

The following temperature profile is an example. Application specific temperature profiles need to be aligned and approved by Infineon Technologies for the fulfillment of quality and reliability targets.

Table 3-71 Example Temperature Profile

$T_J =$	Duration [h]	Comment
$\leq 170^\circ\text{C}$	≤ 30	
$\leq 160^\circ\text{C}$	≤ 120	
$\leq 150^\circ\text{C}$	≤ 220	
$\leq 140^\circ\text{C}$	≤ 350	
$\leq 130^\circ\text{C}$	≤ 780	
$\leq 120^\circ\text{C}$	≤ 1600	
$\leq 110^\circ\text{C}$	≤ 3000	
$\leq 100^\circ\text{C}$	≤ 7000	
$\leq 90^\circ\text{C}$	≤ 8000	
$\leq 80^\circ\text{C}$	≤ 2400	
$\leq 70^\circ\text{C}$	≤ 1000	
	≤ 24500	total time

3.32 Package Outline

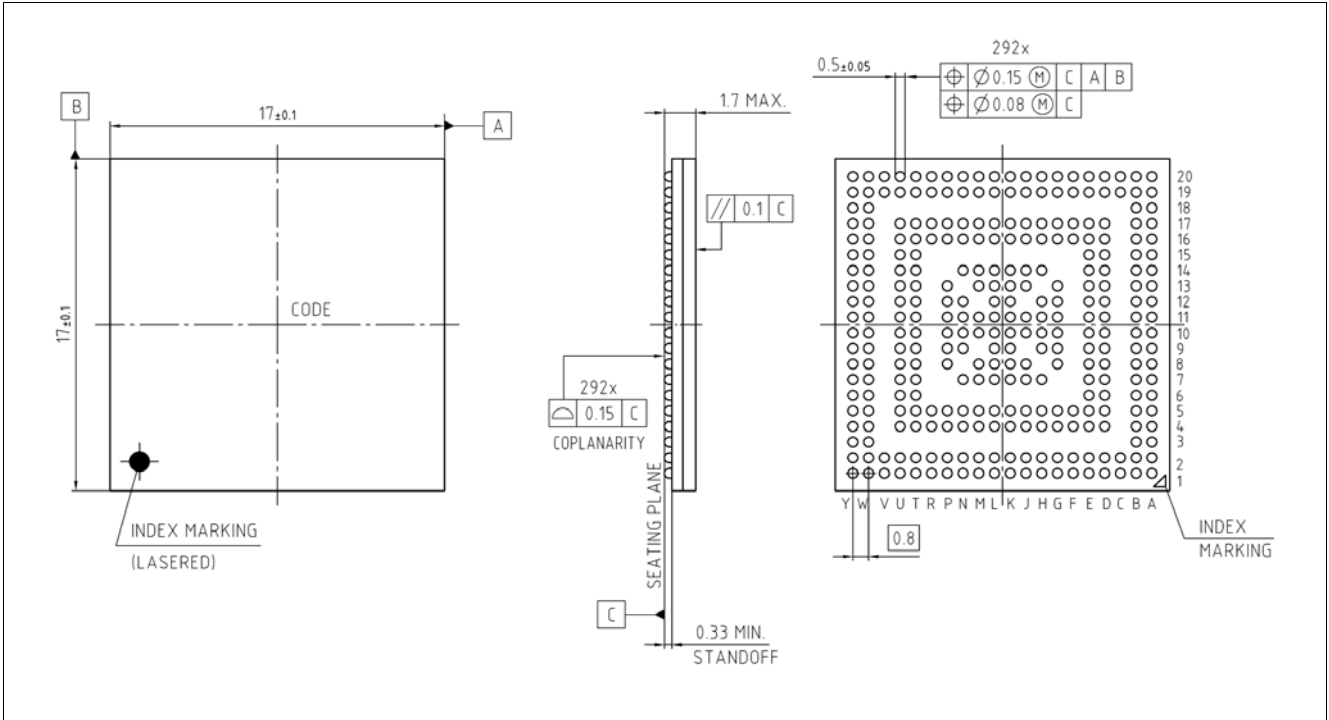

Figure 3-25 Package Outlines LFBGA-292

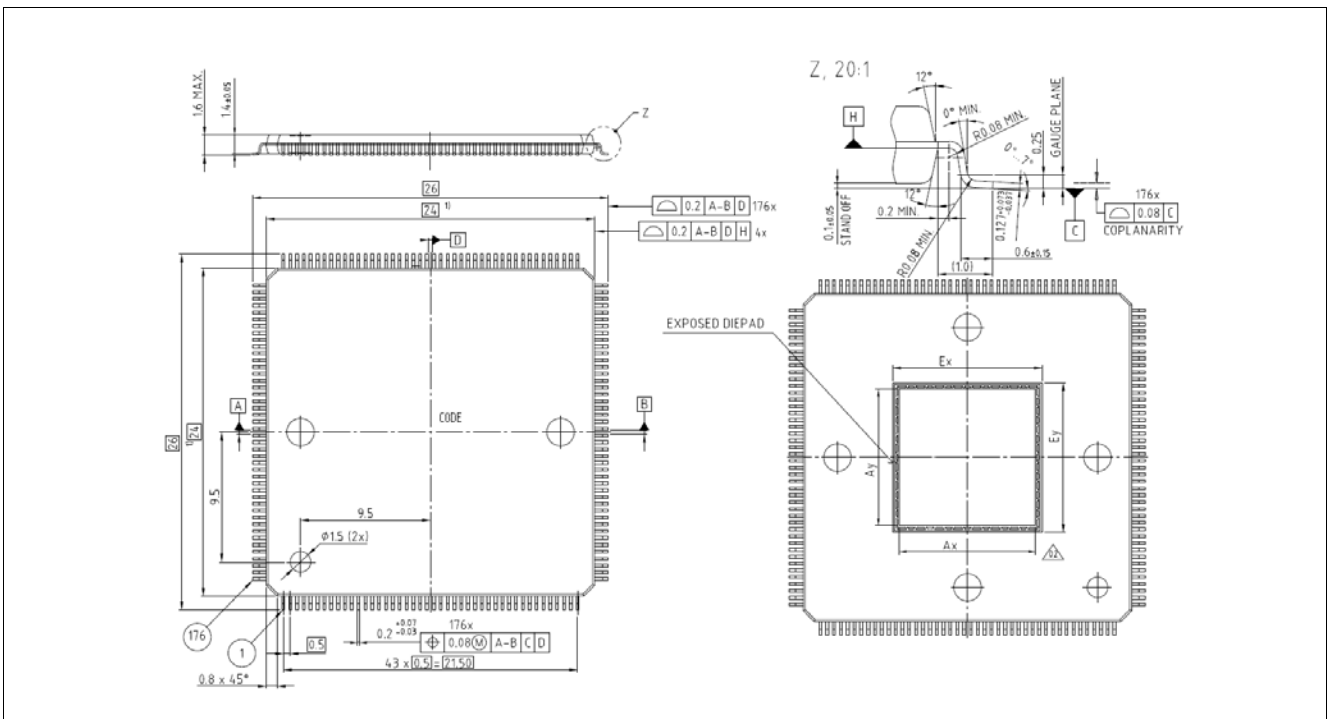

Figure 3-26 Package Outlines LQFP-176

Electrical Specification Package Outline

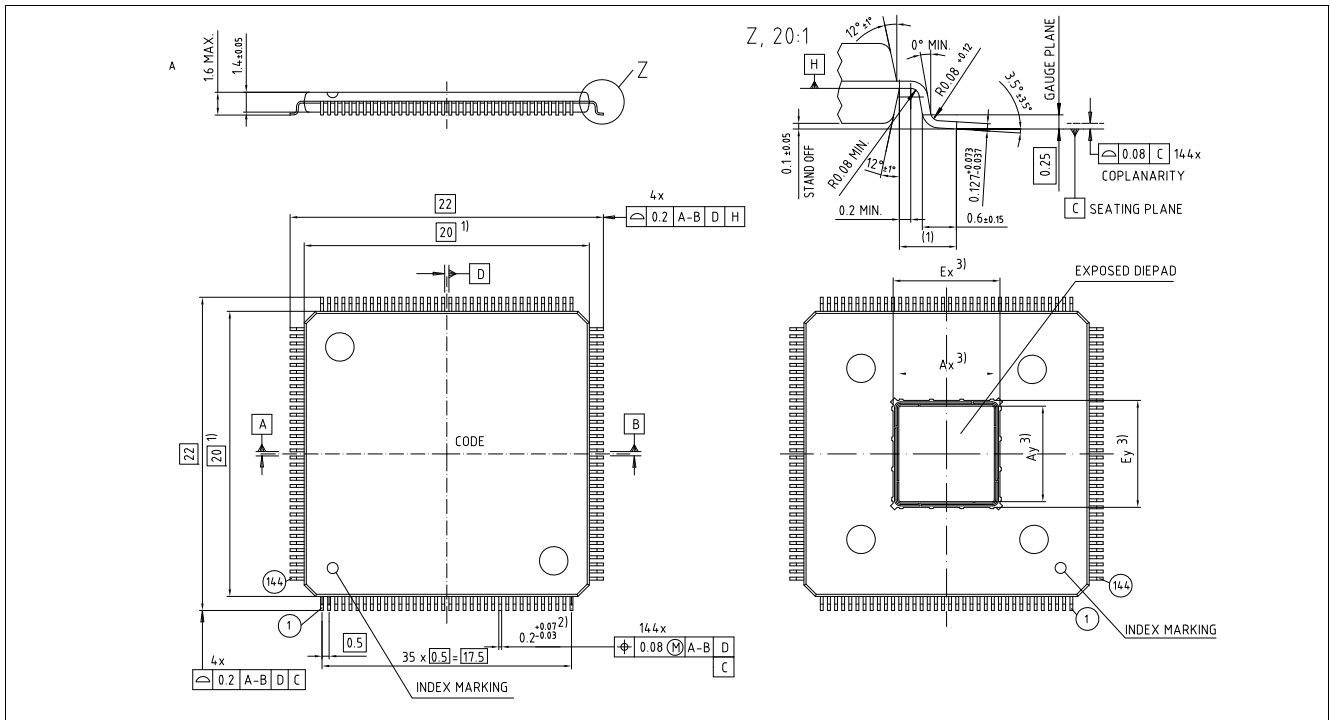

Figure 3-27 Package Outlines LQFP-144

Table 3-72 Exposed Pad Dimensions

Ex; nominal EPad size	8.7 mm ± 50 µm
Ey; nominal EPad size	8.7 mm ± 50 µm
Ax; solderable EPad size	7.9 mm ± 50 µm
Ay; solderable EPad size	7.9 mm ± 50 µm

You can find all of our packages, sorts of packing and others in our Infineon Internet Page “Products”: <http://www.infineon.com/packages>.

3.32.1 Package Parameters

Table 3-73 Package Parameters

Parameter	Symbol	Values			Unit	Note / Test Condition
		Min.	Typ.	Max.		
Thermal resistance (junction to ambient) ¹⁾	RTH_JA CC	-	-	22	K/W	LFBGA-292
		-	-	18	K/W	LQFP-144
		-	-	17	K/W	LQFP-176
Thermal resistance (junction to case bottom) ¹⁾	RTH_JCB CC	-	-	4.5	K/W	LFBGA-292
		-	-	2	K/W	LQFP-144
		-	-	2	K/W	LQFP-176

Table 3-73 Package Parameters (cont'd)

Parameter	Symbol	Values			Unit	Note / Test Condition
		Min.	Typ.	Max.		
Thermal resistance (junction to case top) ¹⁾	RTH_JCT CC	-	-	5	K/W	LFBGA-292
		-	-	10	K/W	LQFP-144
		-	-	10	K/W	LQFP-176

1) The top and bottom thermal resistances between the case and the ambient (RTH_CTA, RTH_CBA) are to be combined with the thermal resistances between the junction and the case given above (RTH_JCT, RTH_JCB), in order to calculate the total thermal resistance between the junction and the ambient (RTH_JA). The thermal resistances between the case and the ambient (RTH_CTA, RTH_CBA) depend on the external system (PCB, case) characteristics and are under user responsibility.

The junction temperature can be calculated using the following equation: $T_J = T_A + RTH_JA * P_D$, where the RTH_JA is the total thermal resistance between the junction and the ambient.

Thermal resistances as measured by the 'cold plate method' (MIL SPEC-883 Method 1012.1).

4 History

Version 0.4 is the first version of this document.

4.1 Changes from Version 0.4 to Version 0.6

Changes in chapter “Pin Definition and Functions”

- Changes in chapter TC37x T and TP - Pin Definition and Functions for package variant LFBGA-292
 - Changes in LFBGA-292 Package Variant 'Port 00 Functions' table; P00.0, P00.1, P00.2, P00.3, P00.4, P00.5, P00.6, P00.7, P00.8, P00.9, P00.10, P00.11, P00.12
 - Changes in LFBGA-292 Package Variant 'Port 01 Functions' table; P01.5
 - Changes in LFBGA-292 Package Variant 'Port 02 Functions' table; P02.0, P02.1, P02.2, P02.3, P02.4, P02.5, P02.6, P02.7, P02.8,
 - Changes in LFBGA-292 Package Variant 'Port 10 Functions' table; P10.2, P10.5, P10.6, P10.7, P10.8
 - Changes in LFBGA-292 Package Variant 'Port 11 Functions' table; P11.0, P11.1, P11.2, P11.3, P11.4, P11.5, P11.6, P11.10, P11.12, P11.14
 - Changes in LFBGA-292 Package Variant 'Port 13 Functions' table; P13.1, P13.2
 - Changes in LFBGA-292 Package Variant 'Port 14 Functions' table; P14.2, P14.3, P14.4, P14.5, P14.9, P14.10
 - Changes in LFBGA-292 Package Variant 'Port 15 Functions' table; P15.4, P15.5
 - Changes in LFBGA-292 Package Variant 'Port 20 Functions' table; P20.0, P20.3, P20.14
 - Changes in LFBGA-292 Package Variant 'Port 21 Functions' table; P21.0, P21.2, P21.3, P21.4, P21.5
 - Changes in LFBGA-292 Package Variant 'Port 22 Functions' table; P22.0, P22.1, P22.2, P22.4, P22.5, P22.6, P22.7, P22.8, P22.9, P22.10, P22.11
 - Changes in LFBGA-292 Package Variant 'Port 23 Functions' table; P23.1, P23.2, P23.3, P23.4, P23.5, P23.6, P23.7
 - Changes in LFBGA-292 Package Variant 'Port 32 Functions' table; P32.0, P32.1, P32.2, P32.3, P32.4, P32.6, P32.7
 - Changes in LFBGA-292 Package Variant 'Port 33 Functions' table; P33.0, P33.2, P33.5, P33.7, P33.10, P33.12, P33.13
 - Changes in LFBGA-292 Package Variant 'Port 34 Functions' table; P34.1, P34.2
 - Changes in LFBGA-292 Package Variant; Buffer Type changed for all Ports
 - Changes in LFBGA-292 Package Variant 'Analog Inputs' table; Buffer Type and Functions changed for all balls
 - Changes in LFBGA-292 Package Variant 'System I/O' table; Buffer Type changed for all balls
 - Changes in LFBGA-292 Package Variant 'System I/O' table; Symbol changed for balls Y17, W17
 - Changes in LFBGA-292 Package Variant 'System I/O' table; Function changed for balls Y17, W17,
 - Changes in LFBGA-292 Package Variant; 'Supply' table; Symbol and Function changed for balls L20, N19, N20
- Changes in chapter TC37x TE - Pin Definition and Functions for package variant LFBGA-292
 - Changes in LFBGA-292 Package Variant 'Port 00 Functions' table; P00.1, P00.2, P00.3, P00.4, P00.7, P00.8, P00.9, P00.10, P00.11, P00.12
 - Changes in LFBGA-292 Package Variant 'Port 01 Functions' table; P01.5
 - Changes in LFBGA-292 Package Variant 'Port 02 Functions' table; P02.3, P02.4, P02.5

History Changes from Version 0.4 to Version 0.6

- Changes in LFBGA-292 Package Variant 'Port 10 Functions' table; P10.2, P10.5, P10.6
- Changes in LFBGA-292 Package Variant 'Port 11 Functions' table; P11.0, P11.1, P11.2, P11.3, P11.4, P11.5, P11.10, P11.12
- Changes in LFBGA-292 Package Variant 'Port 13 Functions' table; P13.1, P13.2
- Changes in LFBGA-292 Package Variant 'Port 14 Functions' table; P14.2, P14.3, P14.4, P14.5
- Changes in LFBGA-292 Package Variant 'Port 15 Functions' table; P15.4, P15.5
- Changes in LFBGA-292 Package Variant 'Port 20 Functions' table; P20.0, P20.6
- Changes in LFBGA-292 Package Variant 'Port 21 Functions' table; P21.2, P21.3, P21.4, P21.5
- Changes in LFBGA-292 Package Variant 'Port 23 Functions' table; P23.1
- Changes in LFBGA-292 Package Variant 'Port 32 Functions' table; P32.1, P32.2, P32.4
- Changes in LFBGA-292 Package Variant 'Port 33 Functions' table; P33.0, P33.2, P33.5, P33.7, P33.10
- Changes in LFBGA-292 Package Variant; Buffer Type changed for all Ports
- Changes in LFBGA-292 Package Variant 'Analog Inputs' table; Buffer Type and Functions changed for all balls
- Changes in LFBGA-292 Package Variant 'System I/O' table; Buffer Type changed for all balls
- Changes in LFBGA-292 Package Variant 'System I/O' table; Symbol changed for balls Y17, W17, M20, M19
- Changes in LFBGA-292 Package Variant; 'Supply' table; Symbol and Function changed for balls L20, N19, N20
- Changes in chapter TC37x T and TP - Pin Definition and Functions for package variant LQFP-176
 - Changes in LQFP-176 Package Variant 'Port 00 Functions' table; P00.1, P00.2, P00.3, P00.4, P00.7, P00.8, P00.9, P00.10, P00.11, P00.12
 - Changes in LQFP-176 Package Variant 'Port 02 Functions' table; P02.3, P02.4, P02.5
 - Changes in LQFP-176 Package Variant 'Port 10 Functions' table; P10.2, P10.5, P10.6
 - Changes in LQFP-176 Package Variant 'Port 11 Functions' table; P11.2, P11.3, P11.6, P11.10, P11.12
 - Changes in LQFP-176 Package Variant 'Port 13 Functions' table; P13.1, P13.2
 - Changes in LQFP-176 Package Variant 'Port 14 Functions' table; P14.2, P14.3, P14.4, P14.5
 - Changes in LQFP-176 Package Variant 'Port 15 Functions' table; P15.4, P15.5
 - Changes in LQFP-176 Package Variant 'Port 20 Functions' table; P20.0
 - Changes in LQFP-176 Package Variant 'Port 21 Functions' table; P21.2, P21.3, P21.4, P21.5
 - Changes in LQFP-176 Package Variant 'Port 23 Functions' table; P23.1
 - Changes in LQFP-176 Package Variant 'Port 32 Functions' table; P32.0, P32.1, P32.2, P32.4
 - Changes in LQFP-176 Package Variant 'Port 33 Functions' table; P33.0, P33.2, P33.5, P33.7, P33.10
 - Changes in LQFP-176 Package Variant; Buffer Type changed for all Ports
 - Changes in LQFP-176 Package Variant 'Analog Inputs' table; Buffer Type and Functions changed for all pins
 - Changes in LQFP-176 Package Variant 'System I/O' table; Buffer Type changed for all pins
 - Changes in LQFP-176 Package Variant 'System I/O' table; Symbol and function changed for pins 84, 85
 - Changes in LQFP-176 Package Variant; 'Supply' table; Symbol and Function changed for pins e_pad, 101, 104
- Changes in chapter TC37x TE - Pin Definition and Functions for package variant LQFP-176
 - Changes in LQFP-176 Package Variant 'Port 00 Functions' table; P00.0, P00.1, P00.2, P00.3, P00.4, P00.5, P00.6, P00.7, P00.8, P00.9, P00.10, P00.11, P00.12

History Changes from Version 0.4 to Version 0.6

- Changes in LQFP-176 Package Variant 'Port 02 Functions' table; P02.0, P02.1, P02.2, P02.3, P02.4, P02.5, P02.6, P02.7, P02.8
- Changes in LQFP-176 Package Variant 'Port 10 Functions' table; P10.2, P10.5, P10.6, P10.7, P10.8
- Changes in LQFP-176 Package Variant 'Port 11 Functions' table; P11.2, P11.3, P11.6, P11.10, P11.12
- Changes in LQFP-176 Package Variant 'Port 13 Functions' table; P13.1, P13.2
- Changes in LQFP-176 Package Variant 'Port 14 Functions' table; P14.2, P14.3, P14.4, P14.5, P14.9, P14.10
- Changes in LQFP-176 Package Variant 'Port 15 Functions' table; P15.4, P15.5
- Changes in LQFP-176 Package Variant 'Port 20 Functions' table; P20.0, P20.3,
- Changes in LQFP-176 Package Variant 'Port 21 Functions' table; P21.0, P21.2, P21.3, P21.4, P21.5
- Changes in LQFP-176 Package Variant 'Port 22 Functions' table; P22.0, P22.1, P22.2
- Changes in LQFP-176 Package Variant 'Port 23 Functions' table; P23.1, P23.2, P23.3, P23.4, P23.5
- Changes in LQFP-176 Package Variant 'Port 32 Functions' table; P32.0, P32.1, P32.2, P32.3, P32.4
- Changes in LQFP-176 Package Variant 'Port 33 Functions' table; P33.0, P33.2, P33.5, P33.7, P33.10, P33.12, P33.13
- Changes in LQFP-176 Package Variant; Buffer Type changed for all Ports
- Changes in LQFP-176 Package Variant 'Analog Inputs' table; Buffer Type and Functions changed for all pins
- Changes in LQFP-176 Package Variant 'System I/O' table; Buffer Type changed for all pins
- Changes in LQFP-176 Package Variant 'System I/O' table; Symbol and function changed for pins 84, 85
- Changes in LQFP-176 Package Variant 'System I/O' table; function changed for pins 102, 103
- Changes in LQFP-176 Package Variant; 'Supply' table; Symbols and Functions changed for pins 101, 104
- Changes in LQFP-176 Package Variant; 'Supply' table; Symbol and Function added for pin 177
- Changes in chapter TC37x TE - Pin Definition and Functions for package variant LQFP-144
 - Changes in LQFP-144 Package Variant 'Port 00 Functions' table; P00.0, P00.1, P00.2, P00.3, P00.4, P00.5, P00.6, P00.7, P00.8, P00.9, P00.12
 - Changes in LQFP-144 Package Variant 'Port 02 Functions' table; P02.0, P02.1, P02.2, P02.3, P02.4, P02.5, P02.6, P02.7, P02.8
 - Changes in LQFP-144 Package Variant 'Port 10 Functions' table; P10.2, P10.5, P10.6
 - Changes in LQFP-144 Package Variant 'Port 11 Functions' table; P11.2, P11.3, P11.6, P11.10, P11.12
 - Changes in LQFP-144 Package Variant 'Port 13 Functions' table; P13.1, P13.2
 - Changes in LQFP-144 Package Variant 'Port 14 Functions' table; P14.2, P14.3, P14.4, P14.5
 - Changes in LQFP-144 Package Variant 'Port 15 Functions' table; P15.4, P15.5
 - Changes in LQFP-144 Package Variant 'Port 20 Functions' table; P20.0, P20.3
 - Changes in LQFP-144 Package Variant 'Port 21 Functions' table; P21.2, P21.3, P21.4, P21.5
 - Changes in LQFP-144 Package Variant 'Port 22 Functions' table; P22.0, P22.1, P22.2
 - Changes in LQFP-144 Package Variant 'Port 23 Functions' table; P23.1
 - Changes in LQFP-144 Package Variant 'Port 32 Functions' table; P32.0, P32.1, P32.4
 - Changes in LQFP-144 Package Variant 'Port 33 Functions' table; P33.5, P33.7, P33.10, P33.12, P33.13
 - Changes in LQFP-144 Package Variant; Buffer Type changed for all Ports
 - Changes in LQFP-144 Package Variant 'Analog Inputs' table; Buffer Type and Functions changed for all pins
 - Changes in LQFP-144 Package Variant 'System I/O' table; Buffer Type changed for all pins

History Changes from Version 0.4 to Version 0.6

- Changes in LQFP-144 Package Variant 'System I/O' table; Symbol and function changed for pins 70, 71
- Changes in LQFP-144 Package Variant 'System I/O' table; function changed for pins 81,82
- Changes in LQFP-144 Package Variant; 'Supply' table; Symbols and Functions changed for pins 83, 80
- Changes in LQFP-144 Package Variant; 'Supply' table; Symbol and Function added for pin 145
- Changes in chapter “Pad Position Configuration of TC37x”
 - Changes in table “Pad List” for all positions
- Changes in chapter 'Pad Position Definition'
 - Changed description in sub-chapter 'Legend' - Column “Buffer Type”: PU2

Changes in chapter “Electrical Specification”

- Changes in table 'Absolute Maximum Ratings'
 - Changed max value of V_{IN} from 7.0 V to 6.75 V
 - Changed description of V_{DDM} from 'Voltage at V_{DDM} , V_{EXT} and V_{FLEX} power supply pins with respect to V_{SS} ' to 'Voltage at V_{DDM} , V_{EXT} , V_{FLEX} and V_{EVRSB} power supply pins with respect to V_{SS} '
 - Changed note of V_{DDM} from '7.0 V' to '6.75 V'
 - Added footnote 2) to V_{DD}
 - Changed order of footnotes
- Changes in table 'Overload Parameters'
 - Changed note of I_{INANA}
 - Removed parameters of I_{ID}
 - Changed note of K_{OVAN}
 - Changed parameter conditions of K_{OVAP}
 - Added footnote 2) to K_{OVAP} and K_{OVAN}
- Changes in 'Operating Conditions' table
 - Added footnote 1) to V_{DD}
 - Changed order of footnotes
- Changes in table 'PORST Pad' of Standard Pads
 - Change value name of parameter HYS
 - Changed notes of parameter I_{OZ}
 - Added value of parameter V_{IH}
 - Added value of parameter V_{IL}
 - Add footnote 2) to I_{PDL}
- Changes in table 'Fast 5V GPIO' of Standard Pads
 - Changed values and conditions of parameter I_{OZ}
 - Combined equal values of I_{OZ} in single lines
 - Changed conditions of parameter t_{RF}
 - Changed value names of parameter of V_{IH}
 - Changed value names of parameter HYS
 - Changed value names of parameter V_{IL}
 - Changed conditions of parameter V_{ILD}
 - Changed parameter t_{SET}
 - Added footnote 1) for t_{RF}
 - Changed footnote 2) for t_{RF}

History Changes from Version 0.4 to Version 0.6

- Added footnote 4) for I_{PUH}
- Added footnote 5) for I_{PDL}
- Changed order of footnotes
- Changes in table 'Fast 3.3V GPIO' of Standard Pads
 - Changed value names of parameter HYS
 - Changed condition of parameter t_{RF}
 - Changed value names of parameter V_{IH}
 - Changed value of parameter V_{IL}
 - Changed condition of parameter V_{ILD}
 - Changed values and conditions of parameter I_{OZ}
 - Combined equal values of I_{OZ} in single lines
 - Changed parameter t_{SET}
 - Added footnote 1) for t_{RF}
 - Changed footnote 2) for t_{RF}
 - Added footnote 4) for I_{PUH}
 - Added footnote 5) for I_{PDL}
 - Changed order of footnotes
- Changes in table 'Slow 5V GPIO' of Standard Pads
 - Changed value names of parameter HYS
 - Changed conditions of parameter I_{PUH}
 - Changed values and conditions of parameter I_{OZ}
 - Combined equal values of I_{OZ} in single line
 - Changed value names of parameter V_{IL}
 - Changed value names of parameter V_{IH}
 - Changed conditions of parameter V_{ILD}
 - Changed parameter t_{SET}
 - Added footnote 1) for t_{RF}
 - Changed footnote 2) for t_{RF}
 - Added footnote 4) for I_{PUH}
 - Added footnote 5) for I_{PDL}
 - Changed order of footnotes
- Changes in table 'Slow 3.3V GPIO' of Standard Pads
 - Changed value names of parameter HYS
 - Changed conditions of parameter I_{PUH}
 - Changed values and conditions of parameter I_{OZ}
 - Combined equal values of I_{OZ} in single line
 - Removed parameter of I_{OZ}
 - Changed value and name of parameter V_{IL}
 - Changed value names of parameter V_{IH}
 - Changed conditions of parameter V_{ILD}
 - Changed parameter of t_{SET}
 - Added footnote 1) for t_{RF}

History Changes from Version 0.4 to Version 0.6

- Changed footnote 2) for t_{RF}
- Added footnote 4) for I_{PUH}
- Added footnote 5) for I_{PDL}
- Changed order of footnotes
- Changes in table 'RFast 5V GPIO' of Standard Pads
 - Changed condition of parameter t_{RF}
 - Changed value names of parameter HYS
 - Changed conditions of parameter I_{OZ}
 - Changed value names of parameter V_{IH}
 - Changed value names of parameter V_{IL}
 - Changed conditions of parameter V_{ILD}
 - Changed parameter of t_{SET}
 - Added footnote 1) for t_{RF}
 - Changed footnote 2) for t_{RF}
 - Added footnote 4) for I_{PUH}
 - Added footnote 5) for I_{PDL}
 - Changed order of footnotes
- Changes in table 'RFast 3.3V pad' of Standard Pads
 - Changed condition of parameter t_{RF}
 - Changed value names of parameter HYS
 - Changed conditions of parameter I_{OZ}
 - Changed value name of parameter V_{IH}
 - Changed value and name of parameter V_{IL}
 - Changed conditions of parameter V_{ILD}
 - Changed parameter t_{SET}
 - Added footnote 1) for t_{RF}
 - Changed footnote 2) for t_{RF}
 - Added footnote 4) for I_{PUH}
 - Added footnote 5) for I_{PDL}
 - Changed order of footnotes
- Changes in table 'Class S 5V' of Standard Pads
 - Changed value names of parameter HYS
 - Changed values of parameter I_{OZ}
 - Changed value name of parameter V_{IH}
 - Changed value name of parameter V_{IL}
 - Changed parameter of t_{SET}
 - Added footnote 2) for I_{PUH}
 - Added footnote 3) for I_{PDL}
- Changes in table 'Class D' of Standard Pads
 - Changed values of parameter I_{OZ}
- Changes in table 'ADC Reference Pads' of Standard Pads
 - Changed notes of parameter I_{OZ2}

History Changes from Version 0.4 to Version 0.6

- Added footnote 1) for I_{OZ2}
- Changes in table 'LVDS - IEEE standard LVDS general purpose link (GPL)' of LVDS Pads
 - Changed condition of parameter R_{in}
 - Added parameter t_{SET_LVDS}
 - Added footnote 1) for t_{RISE20}
 - Added footnote 2) for t_{FALL20}
 - Changed order of footnotes
- Changes in table 'VADC 5V'
 - Added conditions of parameter V_{DDK}
 - Changed parameter naming of dV_{DDK}
 - Added conditions of parameter V_{AREF}
 - Changed values and conditions of V_{AREF}
 - Added note for parameter R_{PDD}
 - Added footnote 1) for V_{AREF}
 - Changed footnote 2) for TUE , EA_{INL} , EA_{DNL} , EA_{GAIN} , EA_{OFF} , EN_{RMS}
 - Added footnote 9) for Q_{CONV}
 - Changed order of footnotes
 - Changed figure 'Equivalent Circuitry for Analog Inputs'
- Changes in table 'DSADC 5V'
 - Added parameter for R_{BIAS}
 - Changed parameters of V_{AREF}
 - Changed parameters of I_{REF}
 - Added parameters of I_{REF}
 - Changed parameters of I_{RMS}
 - Changed parameters of ED_{GAIN}
 - Changed parameters of ED_{OFF}
 - Added footnote 2) for I_{RMS} , SNR
 - Added footnote 3) for $SFDR$, ED_{GAIN} , ED_{OFF} ,
 - Changed order of footnotes
- Changes in table 'OSC_XTAL'
 - Removed parameter for V_{IHBX}
 - Removed parameter for V_{ILBX}
 - Added parameter for DC_{X1}
 - Added parameter for J_{ABSX1}
 - Added parameter for SR_{XTAL1}
 - Added footnote 3) for DC_{X1} , J_{ABSX1} , SR_{XTAL1}
- Changes in table 'Back-up Clock'
 - Changed value of f_{SB}
 - Changed footnote 1) for f_{BACKT}
- Changes in table 'DTS PMS'
 - Added parameter conditions for T_{NL}
- Changes in table 'DTS Core'

History Changes from Version 0.4 to Version 0.6

- Added parameter ΔT
- Added parameter conditions for T_{NL}
- Current Consumption
 - Added values and notes for I_{DDRAIL}
 - Changed values for I_{DDRAIL}
 - Added values and notes for $I_{DDPORST}$
 - Changed values and notes for $I_{DDPORST}$
 - Changed value and note for $I_{STANDBY}$
 - Changed value for I_{DDTOT}
 - Changed values for PD
 - Changed footnote 4) for $I_{EXTFLEX}$
 - Changed footnote 7) $I_{STANDBY}$
- Changes in table 'Module Current Consumption'
 - Changed value of parameters of $I_{DDP3PROG}$
 - Changed value of parameters of $I_{EXTLVDS}$
 - Changed value of $I_{DDP3ERASE}$
 - Changed value of parameter I_{SCRSB}
 - Changed value of parameter $I_{SCRIDLE}$
 - Added footnote 5) for I_{SCRSB}
 - Changed order of footnotes
- Changes in table 'Module Core Current Consumption'
 - Changed naming of I_{DDSPU1}
 - Changed condition of parameter $I_{DDLBISt}$
 - Changed value and condition of parameter $I_{DDLMBISt}$
 - Changed footnote 1) for I_{DDHSM}
 - Added footnote 2) for $I_{DDLBISt}$
- Changes in chapter “Single Supply mode”
 - Changed figure and description for 'Single Supply Mode (a)'
 - Changed figure and description for 'Single Supply Mode (e)'
 - Changed figure and description for 'Single Supply Mode (d)'
 - Changed figure and description for 'Single Supply Mode (h)'
- Changes in table 'Reset'
 - Changed value of parameter t_B
 - Changed value of parameter t_{BS}
 - Added parameter $t_{WARMRSTSEQ}$
 - Changed value of parameter t_{BWP}
 - Changed naming and condition of parameter t_{LBISt}
 - Added footnote 2) for t_{EVRPOR}
 - Changed order of footnotes
- Changes in table 'EVR33 LDO'
 - Changed condition of parameter t_{STR}
 - Added parameter for ' ΔV_{OUTTC} '

History Changes from Version 0.4 to Version 0.6

- Changed values and conditions of parameter dV_{OUT} / dV_{IN}
- Added footnote 7) for dV_{OUT} / dI_{OUT}
- Changes in table 'Supply Monitors'
 - Changed value of V_{RSTC}
 - Changed values of parameter V_{EXTMON}
 - Changed condition of parameter t_{MON}
 - Changed footnote 2) for $V_{EXTPRIUV}$, $V_{DDP3PRIUV}$, $V_{DDPRIUV}$,
 - Changed footnote 3) for $V_{DDP3PRIUV}$, $V_{DDPRIUV}$,
 - Added footnote 4) for V_{EXTMON}
 - Added footnote 5) for V_{EXTMON} , $V_{DDP3MON}$, V_{DDMON}
- Changes in table 'EVRC SMPS'
 - Changed values and notes of parameter of ' f_{DCDC} '
 - Changed value of parameter of ' ΔV_{DDDC} '
 - Removed values and notes of parameter C_{OUT}
 - Added values of parameter ' L_{DC} '
 - Changed condition of parameter dV_{DDDC} / dI_{OUT}
- Changed chapter naming from 'Phase Locked Loop (PLL)' to 'System Phase Locked Loop (SYS_PLL)'
- Changes in table 'PLL System'
 - Removed parameter values of ' f_{MV} '
- Changes in table 'PLL Peripheral'
 - Changed description and values of parameter D_{PP}
 - Added parameter D_{PPI}
 - Changed notes of parameter D_{RMS}
 - Changed notes of parameter DP
 - Added parameter J_{ABS25}
- Changes in table 'Master Mode Timing'
 - Added footnote 1) for all parameters
- Changes in table 'LVDS clock/data'
 - Added footnote 3) for all parameters
- Changes in table 'Receive Parameters' of ERAY
 - Changed description of $t_{dCCRxD10}$
- Changes in table 'Flash'
 - Changed description of parameter of N_{DFD}
 - Added parameter N_{DFDC}
 - Added parameter N_{UCBD}
 - Changed condition of parameter for N_{E_EEP10S}
 - Added values for parameter N_{E_EEP10S}
 - Changed condition of parameter for N_{E_HSMS}
 - Added values for parameter N_{E_HSMS}
 - Added parameter $t_{VER_PAGE_DC}$
 - Added parameter $t_{VER_PAGE_DS}$
 - Removed parameter $t_{VER_PAGE_D}$

- Changed order of footnotes
- Changes in table 'Quality Parameters'
 - Changed condition of parameter V_{HBM1}
 - Added footnote 1) for V_{CDM}
 - Added footnote 2) for V_{HBM}
- Changes in table 'Package Outline'
 - Added figures for Package Outline
 - Added tables 'Exposed Pad Dimensions'
- Changes in table 'Package Parameters'
 - Added table 'Package Parameters'
 - Added footnote 1) for all parameters

4.2 Changes from Version 0.6 to Version 0.61

Changes in chapter “Summary of Features”

- Changes in table “Platform Feature Overview” for Debug/AGBT and package variants

Changes in chapter “TC37x Pin Definition and Functions”

- Changes in overview list: spelling of LFBGA-292
- Changes in overview list for package types of LFBGA-292
- Pad Position Configuration for TP, TE and TX variants added
- Package variant LQFP-144 deleted
- Changes in chapter TC37x TP - Pin Definition and Functions for package variant LFBGA-292
 - Changes in 'Port 00 Functions' table; P00.1, P00.2, P00.3, P00.4, P00.5, P00.6, P00.7, P00.8, P00.9, P00.10, P00.11, P00.12
 - Changes in 'Port 01 Functions' table; P01.6
 - Changes in 'Port 02 Functions' table; P02.3, P02.4, P02.5, P02.6, P02.7, P02.8
 - Changes in 'Port 10 Functions' table; P10.3, P10.4, P10.5, P10.6
 - Changes in 'Port 11 Functions' table; P11.5, P11.7, P11.8, P11.9, P11.10, P11.11, P11.12, P11.15
 - Changes in 'Port 12 Functions' table; P12.0
 - Changes in 'Port 13 Functions' table; P13.1, P13.2
 - Changes in 'Port 14 Functions' table; P14.2, P14.3, P14.4, P14.5
 - Changes in 'Port 15 Functions' table; P15.4, P15.5, P15.6
 - Changes in 'Port 20 Functions' table; P20.0, P20.8, P20.14
 - Changes in 'Port 21 Functions' table; P21.0, P21.2, P21.3, P21.4, P21.5, P21.6, P21.7
 - Changes in 'Port 22 Functions' table; P22.0, P22.1, P22.4, P22.5, P22.6, P22.7, P22.8, P22.9, P22.10, P22.11
 - Changes in 'Port 23 Functions' table; P23.1, P23.2, P23.3, P23.4, P23.5, P23.6, P23.7
 - Changes in 'Port 32 Functions' table; P32.2, P32.4
 - Changes in 'Port 33 Functions' table; P33.0, P33.1, P33.2, P33.3, P33.4, P33.5, P33.6, P33.10, P33.12
 - Changes in 'Port 34 Functions' table; P34.5
 - Changes in table “System I/O”
 - Changes in table “Supply”

History Changes from Version 0.6 to Version 0.61

- Changes in chapter TC37x TE and TX - Pin Definition and Functions for package variant LFBGA-292
 - Changed order of Port Function tables
 - Changed spelling of LFBGA-292
 - Changes in 'Port 00 Functions' table; P00.8
 - Changes in 'Port 02 Functions' table; P02.4, P02.5
 - Changes in 'Port 11 Functions' table; P11.5, P11.12
 - Changes in 'Port 13 Functions' table; P13.1, P13.2
 - Changes in 'Port 20 Functions' table; P20.0
 - Changes in 'Port 23 Functions' table; P23.1
 - Changes in 'Port 32 Functions' table; P32.4
- Changes in chapter TC37x T and TP - Pin Definition and Functions for package variant LQFP-176
 - Changes in 'Port 00 Functions' table; P00.1, P00.2, P00.3, P00.4, P00.5, P00.6, P00.7, P00.8, P00.9, P00.10, P00.11, P00.12
 - Changes in 'Port 02 Functions' table; P02.3, P02.4, P02.5, P02.6, P02.7, P02.8
 - Changes in 'Port 10 Functions' table; P10.3, P10.4, P10.5, P10.6
 - Changes in 'Port 11 Functions' table; P11.9, P11.10, P11.11, P11.12
 - Changes in 'Port 13 Functions' table; P13.1, P13.2
 - Changes in 'Port 14 Functions' table; P14.2, P14.3, P14.4, P14.5
 - Changes in 'Port 15 Functions' table; P15.4, P15.5, P15.6
 - Changes in 'Port 20 Functions' table; P20.0, P20.8, P20.14
 - Changes in 'Port 21 Functions' table; P21.0, P21.2, P21.3, P21.4, P21.5, P21.6, P21.7
 - Changes in 'Port 22 Functions' table; P22.0, P22.1
 - Changes in 'Port 23 Functions' table; P23.1, P23.2, P23.3, P23.4, P23.5
 - Changes in 'Port 32 Functions' table; P32.2, P32.4
 - Changes in 'Port 33 Functions' table; P33.0, P33.1, P33.2, P33.3, P33.4, P33.5, P33.6, P33.10, P33.12
 - Changes in table “System I/O”
 - Changes in table “Supply”
- Changes in chapter TC37x TE - Pin Definition and Functions for package variant LQFP-176
 - Changes in 'Port 00 Functions' table; P00.8
 - Changes in 'Port 02 Functions' table; P02.4, P02.5
 - Changes in 'Port 11 Functions' table; P11.12
 - Changes in 'Port 13 Functions' table; P13.1, P13.2
 - Changes in 'Port 15 Functions' table; P15.4, P15.5
 - Changes in 'Port 20 Functions' table; P20.0
 - Changes in 'Port 23 Functions' table; P23.1
 - Changes in 'Port 32 Functions' table; P32.4
 - Changes in table “Supply”
- Deleted chapter TC37x TE - Pin Definition and Functions for package variant LQFP-144
- Changes in chapter “Pad Position Configuration of TC37x TP”
 - Changes in table “Pad List” for different positions
- Added chapter “Pad Position Configuration of TC37x TE and TX”
- Changes in chapter “Legend”

- Added description concerning pinning DB versions for packages

Changes in chapter “Electrical Specification”

- Changes in table 'RFast 3.3V pad'
 - Added parameter for f_{IND}
- Changes in table 'VADC 5V'
 - Added conditions for parameter V_{AIN}
- Changes in table 'DSADC 5V'
 - Added / changed values for parameter I_{RMS} and ED_{GAIN}
 - Added footnote 4)
 - Changed order of footnotes
- Changes in table “Current Consumption”
 - Added footnotes for $I_{EXTFLEX}$
 - Changed footnote for $I_{DDTOTDC3}$
 - Changed footnote for $I_{DDTOTDC5}$
 - Changed footnote for $I_{STANDBY}$
 - Changed footnote 2)
 - Added footnote 4) and 6)
 - Changed order of footnotes
- Changes in table 'Module Current Consumption'
 - Changed condition of $I_{EXTLVDS}$
 - Changed footnotes of I_{DDM}
 - Changed footnote of $I_{SCR SB}$
 - Changed footnote of $I_{SCRIDLE}$
 - Added footnote 3) and 5)
 - Changed order of footnotes
- Changes in table 'Module Core Current Consumption'
 - Changed / added values of parameter I_{DDGTM}
- Changes in table 'Reset'
 - Changed value of of parameter T_{BWP}
 - Changed values of of parameter T_{SCR}
- Changes in table 'Supply Monitors'
 - Changed condition of parameter V_{RST33}
 - Changed condition of parameter V_{RSTC}
- Changes in table 'Package Outline'
 - Changed spelling for figure from LF-BGA-292 to LFBGA-292
 - Deleted figure and table for QFP144
- Changes in table 'Package Parameters'
 - Deleted values and notes for QFP144
 - Changed value for RTH_JACC

4.3 Changes from Version 0.61 to Version 0.7

Changes in chapter “Summary of Features”

- Changes in table “Platform Feature Overview”
 - added package LQFP-144
 - change package name from LFBGA-292-10 to LFBGA-292

Changes in chapter “TC37x Pin Definition and Functions”

- Changes in overview list - package variants of LFBGA-292
 - Split of package variant description for LFBGA-292 - TE and TX version
 - Added package variant LQFP-144
 - Changed package variant figure numbering
- Changes in chapter “LFBGA-292 Package Pinning of TC37x TE”
 - Changes in ‘Port 00 Functions’ table; P00.3, P00.4, P00.8, P00.9, P00.10
 - Changes in ‘Port 01 Functions’ table; P01.6
 - Changes in ‘Port 02 Functions’ table; P02.4, P02.5, P02.6, P02.7, P02.8, P02.11
 - Changes in ‘Port 10 Functions’ table; P10.3, P10.4, P10.6
 - Changes in ‘Port 11 Functions’ table; P11.9, P11.15
 - Changes in ‘Port 13 Functions’ table; P13.1, P13.2
 - Changes in ‘Port 14 Functions’ table; P14.4
 - Changes in ‘Port 15 Functions’ table; P15.4, P15.5, P15.6
 - Changes in ‘Port 20 Functions’ table; P20.0, P20.8, P20.14
 - Changes in ‘Port 21 Functions’ table; P21.2, P21.3, P21.4, P21.5
 - Changes in ‘Port 22 Functions’ table; P22.0, P22.5, P22.10
 - Changes in ‘Port 23 Functions’ table; P23.3, P23.4
 - Changes in ‘Port 32 Functions’ table; P32.2, P32.4
 - Changes in ‘Port 33 Functions’ table; P33.3, P33.10, P33.12
 - Changes in ‘Port 34 Functions’ table; P34.5
 - Changes in table “Analog Inputs”; ball U6, EDSADC; ball T6, EDSADC; ball W2, EDSADC; ball W1, EDSADC; ball M1, EDSADC; ball M2, EDSADC
 - Changes in table “System I/O”; ball L7, K7, P10, P11, L14, G11, K14

Added chapter “LFBGA-292 Package Pinning of TC37x TX”

- **Changes in chapter “LQFP-176 Package Pinning of TC37x TE”**
 - Changes in ‘Port 00 Functions’ table; P00.3, P00.4, P00.8, P00.9, P00.10
 - Changes in ‘Port 02 Functions’ table; P02.4, P02.5, P02.6, P02.7, P02.8
 - Changes in ‘Port 10 Functions’ table; P10.3, P10.4, P10.6
 - Changes in ‘Port 11 Functions’ table; P11.9
 - Changes in ‘Port 13 Functions’ table; P13.1, P13.2
 - Changes in ‘Port 14 Functions’ table; P14.4
 - Changes in ‘Port 15 Functions’ table; P15.4, P15.5, P15.6
 - Changes in ‘Port 20 Functions’ table; P20.0, P20.8, P20.14
 - Changes in ‘Port 21 Functions’ table; P21.2, P21.3, P21.4, P21.5
 - Changes in ‘Port 22 Functions’ table; P22.0

History Changes from Version 0.61 to Version 0.7

- Changes in 'Port 23 Functions' table; P23.3, P23.4
- Changes in 'Port 32 Functions' table; P32.2, P32.4
- Changes in 'Port 33 Functions' table; P33.3, P33.10, P33.12
- Changes in table "Analog Inputs"; pin 44, EDSADC; pin 43, EDSADC; pin 29, EDSADC; pin 28, EDSADC;

Added chapter "LQFP-144 Package Pinning of TC37x TE"
Changes in chapter "Pad Position Configuration of TC37x TE/TX"

- Changes in table "Pad List", number 34, 35, 219, 220, 223, 224, 225, 307,
- Added comment concerning "neighbor pads"

Changes in chapter "Legend"

- Changed referring IO_Spirit_file version

Changes in chapter "Electrical Specification"

- Changes in table 'Operating Conditions'
 - Deleted parameter for f_{EBU}
- Changes in table 'LVDS - IEEE standard LVDS general purpose link (GPL)'
 - Changed value for parameter V_I
 - Changed test condition for parameter V_{idth}
 - Added values for parameter V_{idth}
 - Changed test condition for parameter R_{in}
 - Added notes to LVDS table
- Changes in table 'Current Consumption'
 - Deleted values for parameter I_{DDRAIL}
 - Deleted value for parameter $I_{DDPORST}$
 - Changed value of parameter $I_{EXTRAIL}$
 - Changed test condition for parameter I_{DDTOT}
 - Added values and test condition for parameter I_{DDTOT}
 - Added value for parameter $I_{DDTOTDC3}$
 - Changed test parameter for $I_{DDTOTDC3}$
 - Added value for parameter $I_{DDTOTDC5}$
 - Changed test conditions for $I_{DDTOTDC5}$
 - Changed test conditions for parameter PD
 - Added values for parameter PD
 - Modified footnote 9) for parameter PD
- Changes in table 'Module Core Current Consumption'
 - Changed values for parameter I_{DDCx0}
 - Changed values for parameter I_{DDCxX}
 - Deleted parameter for I_{DDSPU1}
 - Added value for parameter I_{DDCIF}
- Added sub-chapter 'Calculating the 1.25 V Current Consumption'
- Changes in table 'Reset'
 - Changed value for parameter t_{PIP}
- Changes in table 'PLL System'
 - Changed value for parameter f_{REF}

History Changes from Version 0.7 to Version 1.0

- Changes in sub-chapter 'ETH RGMII Parameters'
 - Added figures for ETH RGMII TX and RX signals
- Added sub-chapter 'SDMMC Interface Timing'
- Changes in table 'Flash'
 - Changed value for parameter t_{PRPB5_PF}
 - Changed values for parameter t_{ER_Dev}
- Added figure for Package Outlines LQFP-144
- Changes in table 'Package Parameters'
 - Added value for parameter RTH_JA - QFP144
 - Added value for parameter RTH_JCB - QFP144

Added value for parameter RTH_JCT - QFP144

4.4 Changes from Version 0.7 to Version 1.0

- General changes in Data Sheet TC37x: Data Sheet splitted and renamed to TC37xEXT for feature package TE/TX and TC37x for feature package T/TP
- Changed Data Sheet version 0.7 to 1.0 and from AA-Step to AB-Step
- Changes in table "Platform Feature Overview"
 - Changed GTM features
 - ASIL Level deleted
 - Debug features deleted
 - Changed packages name spelling
- Changes in chapter "TC37x Pin Definition and Functions"
 - Deleted Package Pinning for LFBGA-292-10, TC37x TP
 - Deleted Package Pinning for LQFP-176, TC37x T and TP
 - Deleted Pad Position Configuration of TC37x TP
 - Changed package name spelling (LFBGA-292)
 - Updated "CIF.*" symbol and functional description for all packages
 - Updated EDSADC functional description for all packages
 - Deleted PMS symbol in package LFBGA-292, Port 02, Ball F1
 - Deleted PMS symbol in package LQFP-176, Port 02, Pin 9
 - Deleted PMS symbol in package LQFP-144, Port 02, Pin 9
 - LFBGA-292 (feature package TE): Changes in table "Analog Inputs"; functional descriptions of ball U6, T6, W2, W1, M1, M2
 - LFBGA-292 (feature package TE): Changes in table "System I/O"; functional descriptions of ball G10, G11, K14
 - LFBGA-292 (feature package TX): Changes in table "Analog Inputs"; functional descriptions of ball U6, T6, W2, W1, M1, M2
 - LFBGA-292 (feature package TX): Changes in table "System I/O"; functional descriptions of ball G10, G11, K14
 - LFBGA-176: Changes in table "Analog Inputs"; functional descriptions of pin 44, 43, 29, 28
 - LFBGA-144: Changes in table "Analog Inputs"; changed pin naming of pin E-PAD/145
 - LFBGA-144: Changes in table "Supply"; functional description of pin 36, 35, 27, 26

History Changes from Version 0.7 to Version 1.0

- Added description regarding “neighbor pads” in chapter “Electrical Specification”
- Changes in table "Legend"
 - Spirit version for feature package TC37x TP has been deleted
- Changes in chapter "Electrical Specification"
 - Changed description in table “Absolute Maximum Ratings” for parameter ΣI_{IN}
 - Added footnote to table “Absolute Maximum Ratings”
 - Added footnote in table “Absolute Maximum Ratings” for parameter I_{IN}
 - Changed value in table “Overload Parameters” for parameter V_{OUS}
 - Changed conditions in table “Operating Conditions” for parameter V_{FLEX}
 - Added parameter in table “Operating Conditions” for V_{FLEX2}
 - Changed conditions in table “Fast 5V GPIO” for parameter t_{RF}
 - Changed values in table “Fast 5V GPIO” for parameter HYS
 - Changed conditions in table “Fast 5V GPIO” for parameter I_{OZ}
 - Changed value in table “Fast 5V GPIO” for parameter V_{IH}
 - Changed value in table “Fast 5V GPIO” for parameter V_{IL}
 - Changed condition in table “Fast 5V GPIO” for parameter V_{ILD}
 - Changed conditions in table “Fast 3.3V GPIO” for parameter t_{RF}
 - Changed values in table “Fast 3.3V GPIO” for parameter HYS
 - Changed conditions in table “Fast 3.3V GPIO” for parameter I_{OZ}
 - Changed value in table “Fast 3.3V GPIO” for parameter V_{IH}
 - Changed value in table “Fast 3.3V GPIO” for parameter V_{IL}
 - Changed condition in table “Fast 5V GPIO” for parameter V_{ILD}
 - Changed values in table “Slow 5V GPIO” for parameter HYS
 - Changed conditions in table “Slow 5V GPIO” for parameter I_{OZ}
 - Changed value in table “Slow 5V GPIO” for parameter V_{IH}
 - Changed value in table “Slow 5V GPIO” for parameter V_{IL}
 - Changed condition in table “Slow 5V GPIO” for parameter V_{ILD}
 - Changed values in table “Slow 3.3V GPIO” for parameter HYS
 - Changed conditions in table “Slow 3.3V GPIO” for parameter I_{OZ}
 - Changed value in table “Slow 3.3V GPIO” for parameter V_{IH}
 - Changed value in table “Slow 3.3V GPIO” for parameter V_{IL}
 - Changed condition in table “Slow 3.3V GPIO” for parameter V_{ILD}
 - Changed conditions in table “RFast 5V GPIO” for parameter t_{RF}
 - Changed values in table “RFast 5V GPIO” for parameter HYS
 - Changed conditions in table “RFast 5V GPIO” for parameter I_{OZ}
 - Changed value in table “RFast 5V GPIO” for parameter V_{IH}
 - Changed value in table “RFast 5V GPIO” for parameter V_{IL}
 - Changed condition in table “RFast 5V GPIO” for parameter V_{ILD}
 - Changed conditions in table “RFast 3.3V pad” for parameter t_{RF}
 - Changed values in table “RFast 3.3V pad” for parameter HYS
 - Changed conditions in table “RFast 3.3V pad” for parameter I_{OZ}
 - Changed value in table “RFast 3.3V pad” for parameter V_{IH}

History Changes from Version 0.7 to Version 1.0

- Changed value in table “RFast 3.3V pad” for parameter V_{IL}
- Added table for “Class S 3.3V” parameters to sub-chapter “5V/ 3.3V switchable Pads”
- Changed footnote 1) at table “OSC_XTAL”
- Added power pattern information to sub-chapter “Power Supply Current”
- Deleted values in table “Current Consumption” for parameter $I_{DDPORST}$
- Changed value in table “Current Consumption” for parameter $I_{EXTRAIL}$
- Changed value in table “Current Consumption” for parameter $I_{EVR SB}$
- Changed condition in table “Reset” for parameter $t_{SUPHOLD}$
- Added values and conditions in table “Supply Monitors” for parameter V_{EXTMON}
- Changed conditions in table “Supply Monitors” for parameter $V_{DDP3MON}$
- Changed conditions in table “Supply Monitors” for parameter V_{DDMON}
- Added note regarding power-cycles to table “Supply Ramp”
- Changed symbol in table “EVRC SMPS” for parameter Δf_{DCSPR}
- Changed symbol in table “EVRC SMPS” for parameter n_{DC}
- Added sub-chapter “Camera Interface Timing (CIF)”
- Changed value in table “Quality Parameters” for parameter V_{HBM1}
- Changes in “Package Outline”
 - Changed package name spelling for figure titles
 - Changed packages name spelling in table “Package Parameter”

www.infineon.com

Published by Infineon Technologies AG

OPEN MARKET VERSION

Looking for pricing, stock, or lifecycle information?

Click below to explore more details on WIN SOURCE:

- ⊖ [View TC377TX96F300SABKXUMA1 on WIN SOURCE](#)
- ⊖ [Infineon Technologies Information](#)

Optimize Your Supply Chain with WIN SOURCE Solutions

- ✓ Global Sourcing Solution
- ✓ Obsolete Management
- ✓ Cost Control Management
- ✓ Shortage Management
- ✓ Alternative Solution
- ✓ Excess Inventory Management