



**THE DATASHEET OF
PI3L2500ZHEX**



PI3L2500

2:1 Mux/DeMux 2.5/10 Gigabit Ethernet LAN Switch with Power-down Mode

Features

- 1:2 Gigabit LAN Switch
- Power-down support
- Low bit-to-bit skew: 200ps
- Very Low Crosstalk: -53dB @ 400MHz
- Status Indicator LEDs Switched with Ethernet pairs
- VDD Operating Range: +3.0V to +3.6V
- Enhanced ESD Protection (on A, B, C, LED pins):
 - 1.0kV (CDM), 4kV (HBM)
- 3GHz Bandwidth
- Totally Lead-Free & Fully RoHS Compliant (Notes 1 & 2)
- Halogen and Antimony Free. "Green" Device (Note 3)
- Packaging:
 - 42-contact TQFN (3.5 x 9mm, 0.5 pitch)

Description

The PI3L2500 is a 8-Channel 2:1 multiplexer/demultiplexer LAN Switch with Hi-Z outputs. Industry leading advantages include a propagation delay of less than 250ps, resulting from its low channel resistance and I/O capacitance. The device multiplexes differential outputs from a Gigabit Ethernet transceiver (PHY) device to one of two corresponding B or C outputs. The switch is bidirectional and offers little or no attenuation of the high-speed signals at the outputs. It is designed for low bit-to-bit skew, high channel-to-channel noise isolation and is compatible with various standards, such as 1000/2500/10000 Base-T (Ethernet).

The PI3L2500 provides a Power Down input (PD), which can put the device into standby mode (PD=1) while mobile, eliminating an external power switch.

Generally, this part can be used to replace mechanical relays in low-voltage LAN applications that interface a physical layer over CAT 5 or CAT 6 unshielded twisted pair cable through an isolation transformer.

Block Diagram

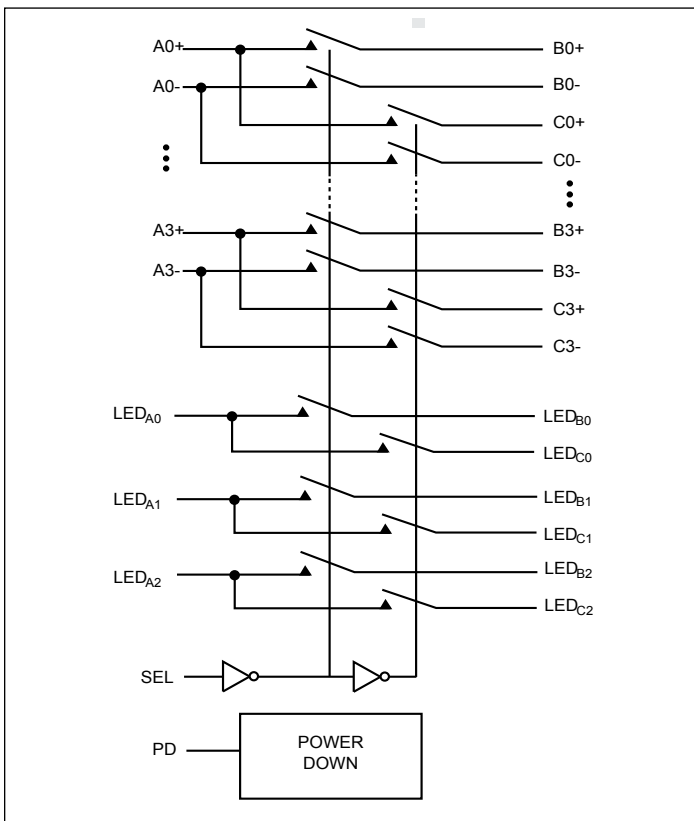

Applications

- Dual Physical Layer Device sharing to one interface connector, or one controller to dual connectors for docking
- Routes signals for 1000/2500/10000 Mbit Ethernet

Ordering Information

Part Number	Package	Description
PI3L2500ZHEX	ZH	42-contact, Very Thin Quad Flat No-Lead (TQFN)

Notes:

1. No purposely added lead. Fully EU Directive 2002/95/EC (RoHS), 2011/65/EU (RoHS 2) & 2015/863/EU (RoHS 3) compliant.
2. See <https://www.diodes.com/quality/lead-free/> for more information about Diodes Incorporated's definitions of Halogen- and Antimony-free, "Green" and Lead-free.
3. Halogen- and Antimony-free "Green" products are defined as those which contain <900ppm bromine, <900ppm chlorine (<1500ppm total Br + Cl) and <1000ppm antimony compounds.
4. E = Pb-free and Green
5. X suffix = Tape/Reel

Looking for pricing, stock, or lifecycle information?

Click below to explore more details on WIN SOURCE:

 [View PI3L2500ZHEX on WIN SOURCE](#)

 [Diodes Incorporated](#) Information

Optimize Your Supply Chain with WIN SOURCE Solutions

-  Global Sourcing Solution
-  Obsolete Management
-  Cost Control Management
-  Shortage Management
-  Alternative Solution
-  Excess Inventory Management