



**THE DATASHEET OF
ADUCM410BCBZ-RL7**



**Precision Analog Microcontroller, 16-Bit Analog Input/Output with MDIO interface,
Arm Cortex-M33****FEATURES**

- ▶ Analog input/output
- ▶ Multichannel, 16-bit, 2 MSPS ADC
 - ▶ Up to 16 external channels
 - ▶ On-chip die temperature monitor
 - ▶ 4 power monitor channels
 - ▶ 4 PGA/TIA channels supporting voltage and current measurements
 - ▶ Fully differential and single-ended modes
 - ▶ 0 V to VREF analog input range
- ▶ 12-bit voltage output DACs
 - ▶ 8× 0 V to 2.5 V, 1 kΩ load
 - ▶ 4× 0 V to 2.5 V, 2.5 kΩ load
- ▶ On-chip low drift voltage reference, 1.25 V or 2.5 V
 - ▶ Buffered 1.25 V or 2.5 V output
- ▶ 4 voltage comparators
- ▶ Microcontroller
 - ▶ 32-bit Arm Cortex-M33 core, 32-bit RISC architecture, FPU
 - ▶ Serial wire port supports code download and debug
- ▶ Clocking options
 - ▶ 16 MHz on-chip oscillator
 - ▶ 160 MHz PLL output with programmable divider
 - ▶ External clock source
- ▶ Memory
 - ▶ 2× 512 kB independent Flash/EE memories
 - ▶ 10,000-cycle Flash/EE endurance
 - ▶ 20-year Flash/EE retention
 - ▶ 128 kB SRAM with ECC
- ▶ Software triggered, in circuit reprogrammability via MDIO or I²C
- ▶ On-chip peripherals
 - ▶ 2× UART, 3× SPI, 3× I²C serial input/output
 - ▶ Multilevel voltage (3.3 V, 1.8 V, 1.2 V) GPIOs
 - ▶ MDIO slave up to 10 MHz
 - ▶ 5 general-purpose timers
 - ▶ Wake-up timer (WUTs)
 - ▶ Watchdog timers (WDTs)
 - ▶ 32-element PLA
 - ▶ 16-bit PWM
 - ▶ 10 external Interrupts
- ▶ Power
 - ▶ Multiple supplies: 3.3 V for voltage DACs and ADCs, and 3.3 V, 1.8 V, or 1.2 V for digital inputs/outputs
 - ▶ Flexible operating modes for low power applications

- ▶ Packages and temperature range
 - ▶ 5 mm × 5 mm 81-ball CSP_BGA and 3.46 mm × 3.46 mm 64-ball WLCSP
 - ▶ BGA package uses ULA molding compounds
 - ▶ Fully specified for -40°C to +105°C operation
- ▶ Tools
 - ▶ Low cost quick start development system
 - ▶ Full third-party support

APPLICATIONS

- ▶ Optical networking 100 Gbps/200 Gbps/400 Gbps and higher frequency modules
- ▶ Industrial control, automation, and instrumentation systems

Rev. B

DOCUMENT FEEDBACK**TECHNICAL SUPPORT**

Information furnished by Analog Devices is believed to be accurate and reliable "as is". However, no responsibility is assumed by Analog Devices for its use, nor for any infringements of patents or other rights of third parties that may result from its use. Specifications subject to change without notice. No license is granted by implication or otherwise under any patent or patent rights of Analog Devices. Trademarks and registered trademarks are the property of their respective owners.

TABLE OF CONTENTS

Features.....	1	RMS Noise Resolution of ADC.....	29
Applications.....	1	Applications Information.....	30
General Description.....	3	Power Supplies.....	30
Functional Block Diagram.....	4	Power-Up Requirements.....	30
Specifications.....	5	Recommended Circuit and Component Values.....	30
Timing Specifications	11	Silicon Anomaly.....	32
Absolute Maximum Ratings.....	16	ADuCM410 Functionality Issues.....	32
Thermal Resistance.....	16	Functionality Issues	32
Electrostatic Discharge (ESD) Ratings.....	16	Section 1. ADuCM410 Functionality Issues.....	32
ESD Caution.....	16	Outline Dimensions.....	33
Typical Performance Characteristics.....	17	Ordering Guide	33
Pin Configurations and Function Descriptions.....	18	Evaluation Boards.....	33
Theory of Operation.....	28		

REVISION HISTORY**11/2021—Rev. A to Rev. B**

Changes to Offset Error Parameter and Actual Offset Error Parameter, Table 1.....	5
Change to Table 10.....	16
Changes to Table 13.....	23
Added Silicon Anomaly Section, ADuCM410 Functionality Issues Section, Functionality Issues Section, Table 16, and Section 1. ADuCM410 Functionality Issues Section; Renumbered Sequentially.....	32

GENERAL DESCRIPTION

The ADuCM410 is a fully integrated, single package device that includes high performance analog peripherals together with digital peripherals (controlled by a 160 MHz Arm® Cortex™-M33 processor) and integrated flash for code and data.

The analog-to-digital converter (ADC) on the ADuCM410 provides 16-bit, 2 MSPS data acquisition using up to 16 input pins that can be programmed for single-ended or differential operation with a programmable gain amplifier (PGA) or transimpedance amplifier (TIA) for voltage and current measurements. Additionally, the die temperature and supply voltages can be measured.

The ADC input voltage is 0 V to VREF. A sequencer is provided that allows a user to select a set of ADC channels to be measured in sequence without software involvement during the sequence. The sequence can optionally repeat automatically at a user-selectable rate.

Up to 12 channels of 12-bit voltage digital-to-analog converters (VDACs) are provided with output buffers supported.

The ADuCM410 can be configured so that the digital and analog outputs retain their output voltages through a watchdog or software reset sequence. Therefore, a product can remain functional even while the ADuCM410 is resetting itself.

The ADuCM410 has a low power Arm Cortex-M33 processor and a 32-bit reduced instruction set computer (RISC) machine that offers up to 240 MIPS peak performance with a floating-point unit (FPU). Also integrated are 2× 512 kB Flash/EE memories and 128 kB static random access memory (SRAM)—both with single-error correction (SEC) and double error detection (DED) error checking and correction (ECC). The flash comprises two separate 512 kB blocks supporting execution from one flash block and simultaneous writing and/or erasing of the other flash block.

The ADuCM410 operates from an on-chip oscillator and has a phase-locked loop (PLL) of 160 MHz. This clock can optionally be divided down to reduce current consumption. Additional low power modes can be set via the ADuCM410 software.

The device includes a management data input/output (MDIO) interface capable of operating up to 10 MHz. User programming is eased by incorporating physical address (PHYADR) and device address (DEVAD) hardware comparators. The nonerasable kernel code combined with flags in user flash allow user code to reliably switch between the two hardware independent flash blocks.

The ADuCM410 integrates a range of on-chip peripherals that can be configured under software control, as required in the application. These peripherals include 2× universal asynchronous receiver transmitter (UART), 3× I²C, and 3× serial peripheral interface (SPI) serial input/output communication controllers, general-purpose inputs/outputs (GPIOs), 32-element programmable logic arrays (PLAs), five general-purpose timers, a wake-up timer (WUT), and a system watchdog timer (WDT). A 16-bit pulse-width modulation (PWM) with eight output channels is also provided.

The GPIO pins (Px.x) power up in high impedance input mode. In output mode, the software chooses between open-drain mode and push/pull mode. The pull-up and pull-down resistors can be disabled and enabled in the software. The GPIO pins can be configured with different voltage levels according to the IOVDDx pin, such as 3.3 V, 1.8 V, and 1.2 V. In GPIO output mode, the inputs can remain enabled to monitor the GPIO pins. The GPIO pins can also be programmed to handle digital or analog peripheral signals, in which case, the pin characteristics are matched to the specific requirement.

A large support ecosystem is available for the Arm Cortex-M33 processor to ease product development of the ADuCM410. Access is via the Arm serial wire debug port. On-chip factory firmware supports in-circuit serial download via MDIO or I²C. These features are incorporated into a low cost, quick start development system supporting this precision analog microcontroller.

Note that throughout this data sheet, multifunction pins, such as VDAC7/P4.2, are referred to either by the entire pin name or by a single function of the pin, for example, P4.2, when only that function is relevant.

FUNCTIONAL BLOCK DIAGRAM

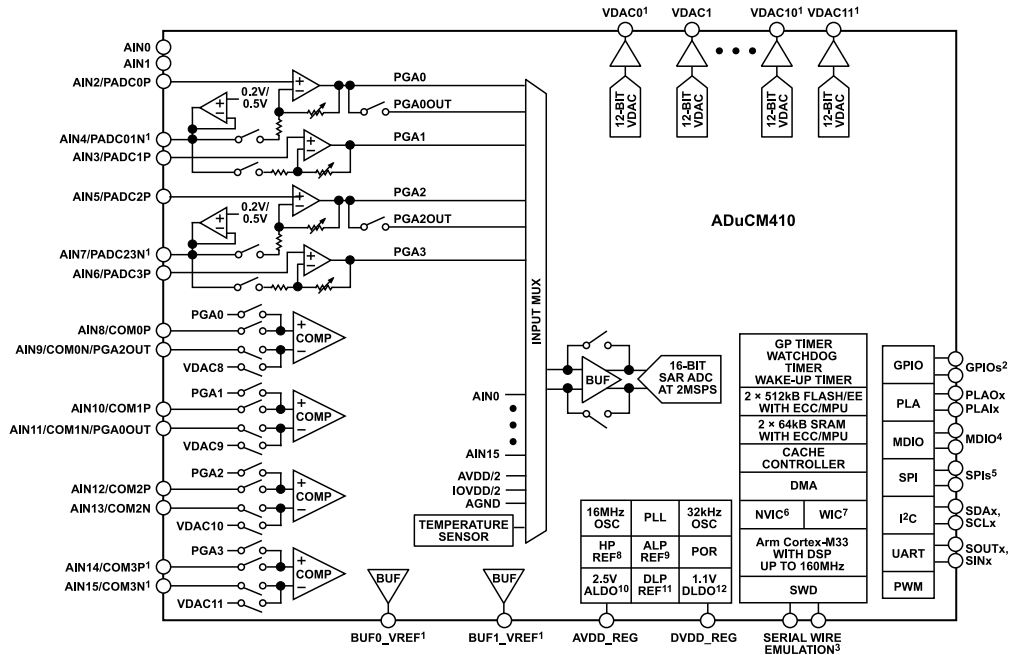

¹THIS IS A PARTIAL FUNCTION OF A MULTIFUNCTION PIN. FOR EXAMPLE, VDAC0 AND AIN4/PADC01N ARE SEPARATE FUNCTIONS ON THE SAME PIN, AIN4/PADC01N/VDAC0.
²GPIOs REFER TO Px.x.
³SERIAL WIRE EMULATION REFERS TO SWDIO, SWCLK, AND SWO.
⁴MDIO REFERS TO PRTADDRx, MDIO, AND MCK.
⁵SPIs REFER TO SCLKx, CSx, MOSIx, SRDyx, AND MISOx.
⁶NVIC IS NESTED VECTORED INTERRUPT CONTROLLER.
⁷WAKE-UP INTERRUPT CONTROLLER.
⁸HP REF IS HIGH POWER REFERENCE.
⁹ALP REF IS ANALOG LOW POWER REFERENCE.
¹⁰ALDO IS ANALOG LOW DROPOUT REGULATOR.
¹¹DLP REF IS DIGITAL LOW POWER REFERENCE.
¹²DLDO IS DIGITAL LOW DROPOUT REGULATOR.

Figure 1.

801

SPECIFICATIONS

AVDD = IOVDD0 = 2.85 V to 3.6 V, IOVDD1 = 1.2 V or 1.8 V, DVDD = 1.8 V to 3.6 V, VREF = 2.5 V for the internal reference, the core frequency (f_{CORE}) = 160 MHz, and $T_A = -40^\circ\text{C}$ to $+105^\circ\text{C}$, unless otherwise noted. HCLK is the high speed system clock.

Table 1.

Parameter	Min	Typ	Max	Unit	Test Conditions/Comments	
ADC CHANNEL SPECIFICATIONS						
ADC Power-Up Time		5		μs		
Data Rate (f_{ADC})			2	MSPS		
Resolution	16			Bits	2.5 V internal reference	
Integral Nonlinearity	-4	± 1	+3	LSB	Voltage input to AINx, PGA off, differential mode	
	-9.5	± 1	+6	LSB	Voltage input to AINx, PGA off, single-ended mode	
	-9.5	± 5	+8	LSB	PGA voltage input to ADC, G = 2	
		± 4		LSB	G = 4	
		± 5		LSB	G = 6	
		± 5		LSB	G = 8	
		± 8		LSB	G = 10	
					TIA input channels	
		-8	± 3	+12	LSB	TIA resistance (R_{TIA}) = 250 Ω
		-8	± 3	+8	LSB	R_{TIA} = 750 Ω , 2 k Ω
Differential Nonlinearity	-11.5	± 6	+11.5	LSB	R_{TIA} = 5 k Ω	
	-15	± 8	+15	LSB	R_{TIA} = 10 k Ω , 20 k Ω , 100 k Ω	
	-0.9	± 0.9	+1.5	LSB	Differential and single-ended	
					Minimum and maximum range from mean ADC codes for 1000 samples	
DC Code Distribution ¹		± 9		LSB	ADC input = 2 V, single-ended mode, f_{ADC} = 2 MSPS, PGA off	
		± 5		LSB	ADC input = 1 V, differential mode, f_{ADC} = 50 kSPS, PGA gain = 2, oversampling ratio (OSR) = 8	
		± 5		LSB	ADC input = 200 mV, differential mode, f_{ADC} = 50 kSPS, PGA gain = 10, OSR = 8	
		± 5		LSB	TIA mode, gain resistor = 100 k Ω , f_{ADC} = 25 kSPS, OSR = 4, input current = 10 μA	
ENDPOINT ERRORS						
Offset Error	-425	± 150	+330	μV	Voltage inputs only PGA off	
	-770	± 200	+830	μV	PGA channels; voltage input to ADC; G = 2, 4, 6, 8, 10; TIA input channels; all gain settings; current converted to a voltage; not production calibrated; user calibration can remove this error	
	-250	± 150	+225	μV	Gain resistor = 250 Ω , 750 Ω	
	-800	± 250	+800	μV	Gain resistor = 2 k Ω	
	-1250	± 200	+1250	μV	Gain resistor = 5 k Ω	
	-1460	± 250	+1375	μV	Gain resistor = 10 k Ω , 20 k Ω , 100 k Ω	
Offset Error Drift		± 4		$\mu\text{V}/^\circ\text{C}$	PGA off	
Offset Error Drift Matching		± 1		$\mu\text{V}/^\circ\text{C}$	Matching compared to AIN0; for voltage input channels, PGA off only	
Full-Scale Error	-900	± 250	+370	μV	PGA off, voltage input to AINx	
	-0.33	± 0.2	+0.3	% of FS ²	PGA voltage input to ADC; G = 2, 4 (not factory calibrated); user calibration can remove this error	
	-0.5	± 0.2	+0.4	% of FS ²	G = 6, 8, 10 (not factory calibrated); user calibration can remove this error	
	-5	+5	+12	% of FS ²	TIA input channels, all gain settings, current converted to a voltage	
	-1	± 0.5	+1	% of FS ²	Internal channels only	

SPECIFICATIONS

Table 1.

Parameter	Min	Typ	Max	Unit	Test Conditions/Comments
Gain Error Drift		±5		ppm/°C	
Gain Error Drift Matching		±0.5		ppm/°C	Matching compared to AIN0; for voltage input channels, PGA off only
PGA Mismatch Error	-0.3	+0.2	+0.3	%	Error between adjacent gain settings of PGA
PGA Mismatch Error Drift		4		ppm/°C	
DYNAMIC PERFORMANCE					
Signal-to-Noise Ratio (SNR)		84		dB	Input frequency (f_{IN}) = 500 Hz sine wave, sampling frequency (f_{SAMPLE}) = 1 MSPS internally Includes distortion and noise components, voltage input, PGA off, single-ended mode
		89		dB	Voltage input, PGA off, differential mode
Total Harmonic Distortion (THD)		-100		dB	
Peak Harmonic or Spurious Noise		-88		dB	
Channel to Channel Crosstalk		-96		dB	Measured on adjacent channels
ANALOG INPUT (VOLTAGE CHANNELS)					
Input Voltage Ranges					
Differential Mode	$V_{CM} - V_{REF}/(2 \times \text{gain})$		$V_{CM} + V_{REF}/(2 \times \text{gain})$	V	PGA gain = 2, 4, 6, 8, 10; V_{CM} is common-mode voltage
Single-Ended Mode	0		2.5	V	Gain = 1 and PGA = off
Leakage Current		±5		nA	Input voltage to AINx = 0.15 V to 2.5 V (except AIN4 and AIN7)
		±30		nA	AIN4 and AIN7 only
Input Current					Input buffer enabled
	-60	±10	+60	nA	At 100 kHz sample rate from 0.15 V to 2.5 V, AINx = 0.15 V to 2.5 V (except AIN4 and AIN7)
	-60	±50	+135	nA	AIN4 and AIN7 only
	-230	±50	+530	nA	PGA off, 2 MSPS ADC sample rate
Input Capacitance		30		pF	During ADC acquisition
ANALOG INPUT (PGA VOLTAGE CHANNELS)					
PGA Gain Options	1		10		G = 1, 2, 4, 6, 8, or 10
Settling Time	10			µs	
Compliant Range	250		Lower of 2500 or AVDD - 800	mV	
ANALOG INPUT (TIA CURRENT CHANNELS)					
Source and Sink Current Range	-5		+5	mA	
TIA Bias Voltage Range	250		Lower of 2500 or AVDD - 800	mV	
	500		1800	mV	$R_{TIA} = 250 \Omega$
Output Voltage Range	250		Lower of 2500 or AVDD - 800	mV	Except $R_{TIA} = 250 \Omega$
	500		1800	mV	$R_{TIA} = 250 \Omega$
Allowed External Load Capacitance ¹					No external extra capacitors to AGND or to supply on AINx when used as TIA inputs
TIA Gain Resistors					
250 Ω , 750 Ω			120	pF	
2 k Ω , 5 k Ω , 10 k Ω , 20 k Ω , 100 k Ω			30	pF	
Gain Accuracy	-5	+5	+12	%	TIA gain resistor and ADC gain error
Gain Drift over Temperature		60	120	ppm/°C	
Gain Mismatch Error	-0.8	±0.3	+0.9	%	Error introduced when moving up or down one R_{TIA} value

SPECIFICATIONS

Table 1.

Parameter	Min	Typ	Max	Unit	Test Conditions/Comments
ON-CHIP VOLTAGE REFERENCE					
Output Voltage		2.5		V	4.7 μ F decoupling capacitor between ADCREFP and ADCREFN
Accuracy			± 5	mV	$T_A = 25^\circ\text{C}$
Reference Temperature Coefficient		10	30	ppm/ $^\circ\text{C}$	$T_A = -40^\circ\text{C}$ to $+25^\circ\text{C}$ range
		10	20	ppm/ $^\circ\text{C}$	$T_A = 25^\circ\text{C}$ to 105°C range
Power Supply Rejection Ratio (PSRR)					
DC		70		dB	AVDD change effects, 2.85 V to 3.6 V
AC		60		dB	Tested with AVDD noise of 1 kHz, 10 kHz, 100 kHz, and 1 MHz
Output Impedance		2		Ω	Do not use as external reference source, $T_A = 25^\circ\text{C}$
EXTERNAL REFERENCE INPUT					
Input Voltage Range		2.5		V	Only supports 2.5 V external reference input
Input Impedance		5		k Ω	External reference source must be capable of sourcing 500 μ A minimum
BUFFERED REFERENCE VOLTAGE OUTPUTS (BUFx_VREF)					
Output Voltage		1.25 or 2.5		V	1 μ F capacitor required on both outputs
Accuracy			± 6	mV	$T_A = 25^\circ\text{C}$, load = 4 mA
Reference Temperature Coefficient		10	30	ppm/ $^\circ\text{C}$	$T_A = -40^\circ\text{C}$ to $+25^\circ\text{C}$ range
		10	20	ppm/ $^\circ\text{C}$	$T_A = 25^\circ\text{C}$ to 105°C range
Load Regulation		2.5		mV/mA	
Output Impedance		2.5		Ω	
Load Current			4	mA	
PSRR		70		dB	
VOLTAGE DAC (VDAC) CHANNEL SPECIFICATIONS					
DC Accuracy					VDAC Channel 0 to Channel 7: buffer on; load resistance (R_L) = 1 k Ω , load capacitance (C_L) = 100 pF; DACCONx, Bit 9 = 0 (normal drive, unless otherwise stated); VDAC Channel 8 to Channel 11: buffer on, $R_L = 2.5$ k Ω , $C_L = 100$ pF
Resolution	12			Bits	
Relative Accuracy ³	-2	± 1.5	+3	LSB	
Differential Nonlinearity ³	-0.9	± 0.5	+0.9	LSB	Guaranteed monotonic
Calculated Offset Error	-13.5	± 5	+15.5	mV	2.5 V internal reference
Actual Offset Error	-15	+2	+15	mV	Measured at Code 0
	-15	+2	+15	mV	VDAC Channel 0 to Channel 7: DACCONx, Bit 9 = 1; $R_L = 250$ Ω ; $C_L = 100$ pF
Gain Error	-0.7	± 0.2	+0.5	% of FS ²	
	-0.7	± 0.2	+0.5	% of FS ²	VDAC Channel 0 to Channel 7: DACCONx, Bit 9 = 1; $R_L = 250$ Ω ; $C_L = 100$ pF
Offset Error Drift		± 10		$\mu\text{V}/^\circ\text{C}$	
Gain Error Drift		15		ppm/ $^\circ\text{C}$	
Short-Circuit Current		± 32		mA	VDAC Channel 0 to Channel 7
		± 15		mA	VDAC Channel 8 to Channel 11
DAC OUTPUTS					
Output Range ¹	0		2.5	V	VDAC Channel 0 to Channel 7
	0		Lower of 2.5 or AVDD - 0.7	V	VDAC Channel 8 to Channel 11
Output Impedance		1		Ω	

SPECIFICATIONS

Table 1.

Parameter	Min	Typ	Max	Unit	Test Conditions/Comments
DAC AC CHARACTERISTICS					
Slew Rate		2.5		V/ μ s	
Voltage Output Settling Time		10		μ s	
Digital to Analog Glitch Energy		\pm 20		nV-sec	1 LSB change at major carry (where maximum number of bits simultaneously changes in DACDATx register)
COMPARATOR INPUT					
Offset Voltage		\pm 15		mV	The offset voltage is dependent on the comparator being enabled with its input pins connected to external biasing circuits; if the comparator is left powered down or if the inputs to the comparator are left floating, over time the offset error may increase
Bias Current	-30	3 ¹	+43	nA	Noninverting (positive) input
		10 ¹		nA	Inverting (negative) input, hysteresis disabled
		50 ¹		nA	Inverting (negative) input, hysteresis = 10 mV
Voltage Range	740	840	940	nA	Inverting (negative) input, hysteresis = 210 mV
	0.5		AVDD - 1.2	V	Negative input range (reference node of the comparator)
	AGND		AVDD	V	Positive input range to comparator
	0		2.0	V	Differential input range; positive input - negative input voltage
Capacitance		7		pF	
Hysteresis	10	50	210	mV	16 configurable options ⁴
Hysteresis Voltage Accuracy		10	35	% of target hysteresis	10 mV to 35 mV settings
		5	15	% of target hysteresis	50 mV to 210 mV settings
Response Time		5		μ s	
POWER-ON RESET (POR)					
POR Trip Level (DVDD)	1.6		1.77	V	Refers to voltage at DVDD pin Power-on level, see Figure 18
	1.62	1.66	1.7	V	Power-down level (brownout)
Timeout from POR		32		ms	
FLASH MEMORY					
Endurance	10,000			Cycles	2 \times 512 kB, 128 kB SRAM
Data Retention	10			Years	Junction temperature (T _J) = 125°C
	20			Years	T _J = 85°C
INTERNAL HIGH POWER OSCILLATOR					
Accuracy		16	\pm 3	MHz %	
TEMPERATURE SENSOR					
Voltage Output at 25°C		0.13625		V	Indicates die temperature
Voltage Temperature Coefficient		0.4568		mV/°C	
Accuracy	-3	\pm 2	+4.4	°C	
INTERNAL LOW POWER OSCILLATOR					
Accuracy	-10	\pm 7	+10	kHz %	
3.3 V GPIO					
Logic Inputs					IOVDD0 = 3.3 V
Input Low Voltage (V _{INL})			0.99	V	IOVDD \times 0.3
Input High Voltage (V _{INH})	2			V	
Pull-Up Current	120	160	210	μ A	V _{IN} = 0 V
Pull-Down Current	125	163	210	μ A	V _{IN} = 3.3 V

SPECIFICATIONS

Table 1.

Parameter	Min	Typ	Max	Unit	Test Conditions/Comments
Internal Pull-Up/Pull-Down Disabled	-32	+1	+65	nA	IOVDD0 power source
Logic Outputs					
Output High Voltage (V_{OH})	2.4			V	Source current (I_{SOURCE}) = 12 mA
Output Low Voltage (V_{OL})			0.4	V	Sink current (I_{SINK}) = 12 mA; for I ² C SCL0, SCL2, SDA0, and SDA2, I_{SINK} = 20 mA; for I ² C SCL1 and SDA1, I_{SINK} = 12 mA
Input Capacitor			10	pF	
Short-Circuit Current		13		mA	
1.8 V GPIO					IOVDD1 = 1.8 V
Logic Inputs					
V_{INL}			0.54	V	
V_{INH}	1.26			V	
Pull-Up Current	155	194	240	μ A	Input voltage (V_{IN}) = 0 V
Pull-Down Current	170	217	270	μ A	V_{IN} = 1.8 V
Internal Pull-Up or Pull-Down Disabled	-500	+25	+2000	nA	IOVDD1 power source
Logic Outputs					
V_{OH}	1.4			V	I_{SOURCE} = 12 mA
V_{OL}			0.3	V	I_{SINK} = 12 mA
Input Capacitor			10	pF	
Short-Circuit Current		17		mA	
1.2 V GPIO					IOVDD1 = 1.2 V
Logic Inputs					
V_{INL}			0.36	V	
V_{INH}	0.84			V	
Pull-Up Current	55	76	100	μ A	V_{IN} = 0 V
Pull-Down Current	55	82	110	μ A	V_{IN} = 1.2 V
Internal Pull-Up/Pull-Down Disabled	-450	+20	+1510	nA	IOVDD1 power source
Logic Outputs					
V_{OH}	1.0			V	I_{SOURCE} = 6 mA
V_{OL}			0.18	V	I_{SINK} = 6 mA
Input Capacitor			10	pF	
Short-Circuit Current		7		mA	
MDIO					
Logic Inputs					
V_{INL}			0.36	V	
V_{INH}	0.84			V	
Logic Output					
V_{OH}	1.0			V	I_{SOURCE} = 4 mA
V_{OL}			0.2	V	I_{SINK} = 4 mA
Input Capacitor			10	pF	
Short-Circuit Current		7		mA	
MICROCONTROLLER UNIT (MCU) CLOCK RATE					
Using PLL Output		160	163	MHz	
EXTERNAL RESET					
Minimum Pulse Duration	10			μ s	Pin voltage must stay low for this period
PROCESSOR START-UP TIME					
At Power-On		32		ms	Includes kernel power-on execution time
After Reset Event		1		ms	Includes kernel power-on execution time

SPECIFICATIONS

Table 1.

Parameter	Min	Typ	Max	Unit	Test Conditions/Comments
After Processor Power-Down					
Core Sleep (Mode 1) ⁵		30		HCLK cycles	Fixed number of HCLK periods
System Sleep (Mode 2), Hibernate (Mode 3) ⁵		85		μs	HCLK = 160 MHz from PLL
		3		μs	HCLK = 16 MHz from internal oscillator
POWER REQUIREMENTS					
Power Supply Voltage Range					
AVDD to AGND	2.85	3.3	3.6	V	
DVDD to DGND	1.8	1.8 or 3.3	3.6	V	
IOVDD0 to IOGND	2.85	3.3	3.6	V	
IOVDD1 to IOGND	1.08	1.2 or 1.8	1.98	V	If unused, can be tied to DVDD_REG or to DGND
Analog Power Supply Currents					
AVDD Current		900	1050	μA	Analog peripherals in idle mode
Digital Power Supply Current					
Current in Normal Mode					On power-up, GPIOs unloaded
IOVDD0		175	200	μA	
IOVDD1		20	60	μA	
DVDD Current		12	30	mA	
Active Mode		16		mA	Executing typical code (current from all supplies)
		4.8		mA	HCLK = 16 MHz from internal oscillator
Core Sleep (Mode 1) ⁵		11		mA	HCLK = 160 MHz from PLL
		4.3		mA	HCLK = 16 MHz from internal oscillator
System Sleep (Mode 2) ⁵		2.46	19	mA	
Hibernate (Mode 3) ⁵		2.44	17	mA	Full clock, PLL = 160 MHz
Additional Power Supply Currents					
ADC		2.8	3.4	mA	Continuously converting at 2 MSPS
PGA		0.375	0.465	mA	Per powered up PGA, excluding load current
DAC		330	350	μA	Per powered up DAC, excluding load current
Total Supply Current		18.8		mA	Active mode with PLL clock of 160 MHz and ADC enabled

¹ These numbers are not production tested but are guaranteed by design and/or characterization data at production release.

² FS is full scale.

³ VDAC linearity specifications generated using reduced DAC code range of 82 to 4095. For VDAC Channel 8 to Channel 11, end code of 4095 only used when AVDD – 0.7 V > 2.5 V.

⁴ These options include 10 mV, 25 mV, 35 mV, 50 mV, 60 mV, 75 mV, 100 mV, 110 mV, 125 mV, 135 mV, 150 mV, 160 mV, 175 mV, 185 mV, 200 mV, and 210 mV.

⁵ In core sleep mode, the system gates the clock to the Cortex-M33 core after the Cortex-M33 enters sleep mode. In system sleep mode, the system gates the system bus clock and the peripheral bus clock after the Cortex-M33 enters sleep mode. See the [ADuCM410 hardware reference manual](#) for more information about the various power modes.

SPECIFICATIONS

TIMING SPECIFICATIONS

I²C TimingTable 2. I²C Timing in Standard Mode (100 kHz)—Slave/Master

Parameter	Description	Min	Typ	Max	Unit
t _L	SCLx low pulse width	4.7			μs
t _H	SCLx high pulse width	4.0			μs
t _{SHD}	Start condition hold time	4.0			μs
t _{DSU}	Data setup time	250			ns
t _{DHD}	Data hold time (SDAx held internally after falling edge of SCLx, duration set via TCTL register, THDATIN bits)	0		3.45	μs
t _{RSU}	Setup time for repeated start	4.7			μs
t _{PSU}	Stop condition setup time	4.0			μs
t _{BUF}	Bus free time between a stop condition and a start condition	4.7			μs
t _R	Rise time for both SCLx and SDAx			1	μs
t _F	Fall time for both SCLx and SDAx		15	300	ns
t _{VD; DAT}	Data valid time			3.45	μs
t _{VD; ACK}	Data valid acknowledge time			3.45	μs
C _B	Capacitive load for each bus line (not shown in Figure 2)			400	pF

Table 3. I²C Timing in Fast Mode (400 kHz)—Slave/Master

Parameter	Description	Min	Typ	Max	Unit
t _L	SCLx low pulse width	1.3			μs
t _H	SCLx high pulse width	0.6			μs
t _{SHD}	Start condition hold time	0.6			μs
t _{DSU}	Data setup time	100			ns
t _{DHD}	Data hold time (SDAx held internally after falling edge of SCLx, duration set via TCTL register, THDATIN bits)	0			μs
t _{RSU}	Setup time for repeated start	0.6			μs
t _{PSU}	Stop condition setup time	0.6			μs
t _{BUF}	Bus free time between a stop condition and a start condition	1.3			μs
t _R	Rise time for both SCLx and SDAx	20		300	ns
t _F	Fall time for both SCLx and SDAx		15	300	ns
t _{VD; DAT}	Data valid time			0.9	μs
t _{VD; ACK}	Data valid acknowledge time			0.9	μs
C _B	Capacitive load for each bus line (not shown in Figure 2)			400	pF

I²C GPIOs (P0.7 to P0.4 and P1.3 to P1.2) drive strength set to 20 mA.

Table 4. I²C Timing in Fast Mode Plus (1 MHz)—Slave/Master

Parameter	Description	Min	Typ	Max	Unit
t _L	SCLx low pulse width	0.5			μs
t _H	SCLx high pulse width	0.26			μs
t _{SHD}	Start condition hold time.	0.26			μs
t _{DSU}	Data setup time	50			ns
t _{DHD}	Data hold time (SDAx held internally after falling edge of SCLx, duration set via TCTL register, THDATIN bits)	0			μs
t _{RSU}	Setup time for repeated start	0.26			μs
t _{PSU}	Stop condition setup time	0.26			μs
t _{BUF}	Bus-free time between a stop condition and a start condition	0.5			μs

SPECIFICATIONS

Table 4. I²C Timing in Fast Mode Plus (1 MHz)—Slave/Master

Parameter	Description	Min	Typ	Max	Unit
t _R	Rise time for both SCLx and SDAx			120	ns
t _F	Fall time for both SCLx and SDAx			120	ns
t _{VD; DAT}	Data valid time			0.45	μs
t _{VD; ACK}	Data valid acknowledge time			0.45	μs
C _B	Capacitive load for each bus line (not shown in Figure 2)			550	pF

I²C GPIOs (P0.7 to P0.4 and P1.3 to P1.2) drive strength set to 20 mA.

Table 5. I²C Timing in High Speed Mode (3.4 MHz)—Slave Only

Parameter	Description	Min	Typ	Max	Unit
t _L	SCLx low pulse width	160			ns
t _H	SCLx high pulse width	60			ns
t _{SHD}	Start condition hold time.	160			ns
t _{DSU}	Data setup time	10			ns
t _{DHD}	Data hold time (SDAx held internally after falling edge of SCLx, duration set via TCTL register, THDATIN bits)	0			ns
t _{RSU}	Setup time for repeated start	160			ns
t _{PSU}	Stop condition setup time	160			ns
t _{BUF}	Bus-free time between a stop condition and a start condition	200			ns
t _R	Rise time for both SCLx and SDAx Up to C _B = 100 pF Up to C _B = 400 pF	10		40	ns
t _F	Fall time for both SCLx and SDAx Up to C _B = 400 pF	10		40	ns
C _B	Capacitive load for each bus line (not shown in Figure 2)			400	pF

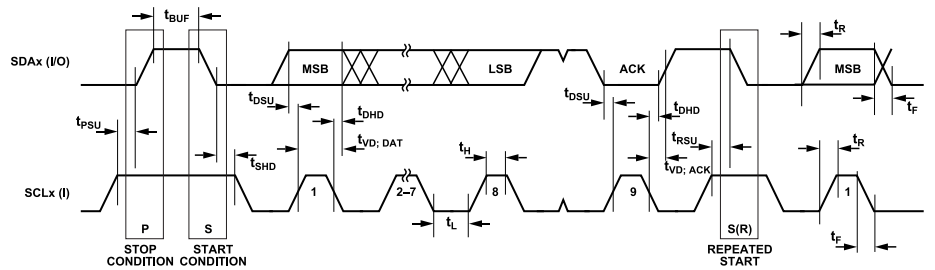

Figure 2. I²C-Compatible Interface Timing

SPECIFICATIONS

SPI Timing Specifications: Slave Mode

SPI GPIOs (P0.3 to P0.0, P1.7 to P1.4, and P2.7 to P2.4) drive strength set to 12 mA, IOVDD1 ≥ 1.2 V, and 40 MHz SPI clock.

See Figure 3 and Figure 4.

Table 6. SPI Slave Mode Timing

Parameter	Symbol	Min	Typ	Max	Unit
TIMING REQUIREMENTS					
to SCLKx Edge	$t_{\overline{CS}}$	25			ns
Minimum valid \overline{CSx} inactive period	$t_{\overline{CS}_M}$	25			ns
SCLKx Low Pulse Width	t_{SL}		10		ns
SCLKx High Pulse Width	t_{SH}		10		ns
Data Input Setup Time Before SCLKx Edge	t_{DSU}	5			ns
Data Input Hold Time After SCLKx Edge	t_{DHD}	5			ns
SWITCHING CHARACTERISTICS					
Data Output Valid After SCLKx Edge	t_{DAV}		10		ns
Data Output Valid After \overline{CSx} Edge	t_{DOCS}		15		ns
\overline{CSx} High After SCLKx Edge	t_{SFS}		8.75		ns

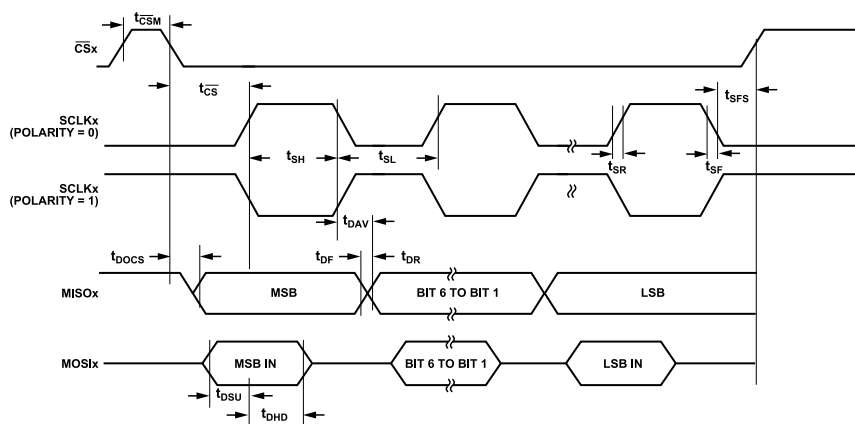

Figure 3. SPI Slave Mode Timing (Serial Clock Phase Mode, CTL Register, Bit 2, CPHA = 0)

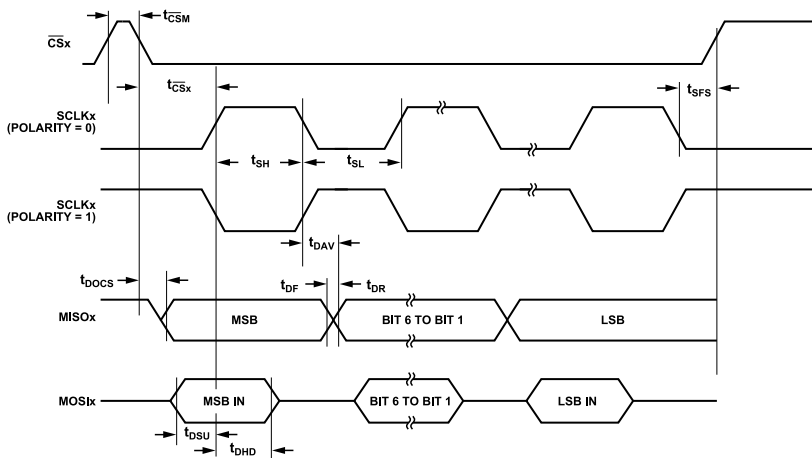

Figure 4. SPI Slave Mode Timing (CPHA = 1)

SPECIFICATIONS

SPI Timing Specifications: Master Mode

SCLKx = 40 MHz, SPI GPIOs (P0.3 to P0.0, P1.7 to P1.4, and P2.7 to P2.4) pin drive strength set to 12 mA. IOVDD1 ≥ 1.2 V. DIV is the SPI clock divider in the SPI baud rate selection register (see the [ADuCM410 hardware reference manual](#) for more information). t_{HCLK} is the time period of HCLK set up by the user.

Table 7. SPI Master Mode Timing (CPHA = 0 and 1)

Parameter	Description	Min	Typ	Max	Unit
t _{SL}	SCLKx low pulse width		(DIV + 1) × t _{HCLK} /2		ns
t _{SH}	SCLKx high pulse width		(DIV + 1) × t _{HCLK} /2		ns
t _{DAV}	Data output valid after SCLKx edge	0			ns
t _{DSU}	Data input setup time before SCLKx edge	5			ns
t _{DHD}	Data input hold time after SCLKx edge	5			ns
t _{DF}	Data output fall time		5		ns
t _{DR}	Data output rise time		5		ns
t _{SR}	SCLKx rise time		5		ns
t _{SF}	SCLKx fall time		5		ns

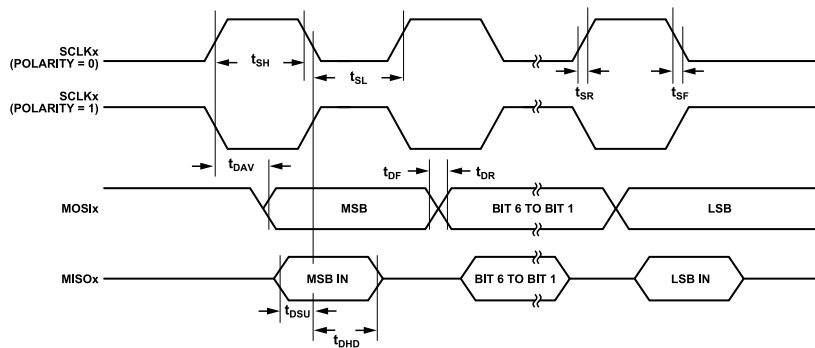

Figure 5. SPI Master Mode Timing (CPHA = 1)

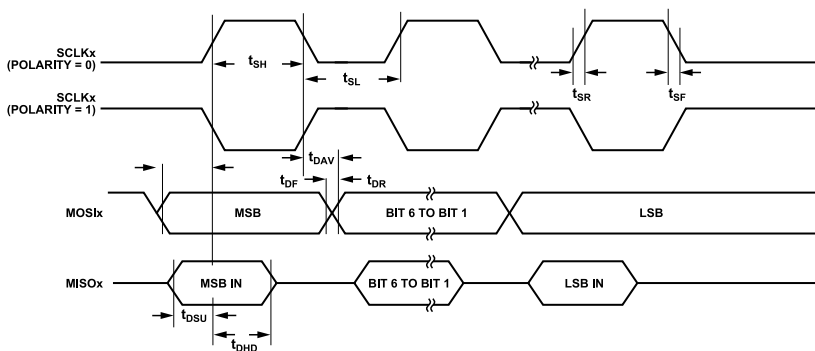

Figure 6. SPI Master Mode Timing (CPHA = 0)

Table 8. MDIO vs. Management Data Clock (MDC) Timing

Parameter ¹	Description	Min	Typ	Max	Unit
Maximum MCK Clock Speed	Push/pull mode			10	MHz
	Open-drain mode, pull-up resistance (R _{PULLUP}) = 312 Ω			4	MHz
t _{SETUP}	MDIO setup before MCK edge (push/pull mode)	5			ns
	Open-drain mode, R _{PULLUP} = 312 Ω	10			ns
t _{HOLD}	MDIO valid after MCK edge (push/pull mode)	7			ns
	Open-drain mode, R _{PULLUP} = 312 Ω	10			ns

SPECIFICATIONS

Table 8. MDIO vs. Management Data Clock (MDC) Timing

Parameter ¹	Description	Min	Typ	Max	Unit
t_{DELAY}	Data output after MCK edge (push/pull mode)			26	ns
	Open-drain mode, $R_{\text{PULLUP}} = 312 \Omega$			100	

¹ In Figure 7, CFP is C formfactor pluggable. V_{IH} is the voltage input high level, and V_{IL} is voltage input low level.

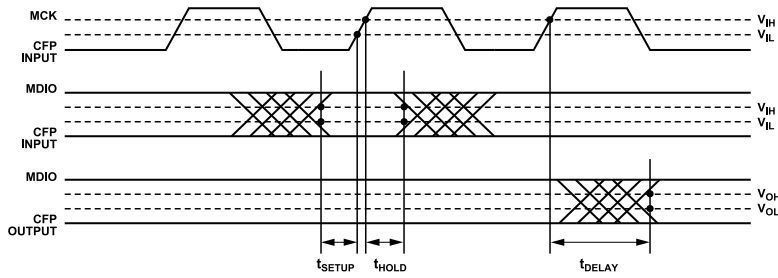

Figure 7. MDIO Timing

ABSOLUTE MAXIMUM RATINGS

Table 9.

Parameter	Rating
AVDD to AGND	-0.3 V to +3.63 V
IOVDD0 to IOGND	-0.3 V to +3.63 V
IOVDD1 to IOGND	-0.3 V to +1.98 V
DVDD to DGND	-0.3 V to +3.63 V
AVDD to IOVDD0	IOVDD0 ± 0.3 V
Analog Input Voltage to AGND (AVDD Range = 2.85 V to 3.6 V)	-0.3 V to AVDD + 0.3 V, must be ≤ 3.63 V
Digital Input Voltage to IOGND	-0.3 V to IOVDD0 + 0.3 V, must be ≤ 3.63 V
Digital Input Voltage to IOGND (P1.0 to P1.7 and P0.0 to P0.3 Only) ¹	-0.3 V to IOVDD1 + 0.3 V, must be ≤ 1.98 V
AGND to DGND	-0.3 V to +0.3 V
IOGND to DGND	-0.3 V to +0.3 V
Total Positive GPIO Pins Current	0 mA to 40 mA
Total Negative GPIO Pins Current	-40 mA to 0 mA
Temperature Ranges	
Storage	-65°C to +150°C
Operating	-40°C to +105°C
Reflow Profiles	
SnPb Assemblies (10 sec to 30 sec)	240°C
Pb-Free Assemblies (20 sec to 40 sec)	260°C
Junction Temperature	150°C

¹ When IOVDD1 is the selected power rail.

Stresses at or above those listed under Absolute Maximum Ratings may cause permanent damage to the product. This is a stress rating only; functional operation of the product at these or any other conditions above those indicated in the operational section of this specification is not implied. Operation beyond the maximum operating conditions for extended periods may affect product reliability.

THERMAL RESISTANCE

Thermal performance is directly linked to printed circuit board (PCB) design and operating environment. Careful attention to PCB thermal design is required.

θ_{JA} is the natural convection junction to ambient thermal resistance measured in a one cubic foot sealed enclosure. θ_{JC} is the junction to case thermal resistance.

Table 10. Thermal Resistance

Package Type	θ_{JA} ¹	θ_{JC}	Unit
BC-81-4	35	12.76	°C/W
CB-64-2	34	0.16	°C/W

¹ JEDEC 2S2P.

ELECTROSTATIC DISCHARGE (ESD) RATINGS

The following ESD information is provided for handling of ESD sensitive devices in an ESD protected area only.

Human body model (HBM) per ANSI/ESDA/JEDEC JS-001. Field induced charged device model (FICDM) per ANSI/ESDA/JEDEC JS-002.

ESD Ratings for ADuCM410

Table 11. ADuCM410, 81-Ball CSP_BGA and 64-Ball WLCSP

ESD Model	Withstand Threshold (kV)	Class
HBM	3	2
FICDM	0.5	C2A

ESD CAUTION



ESD (electrostatic discharge) sensitive device. Charged devices and circuit boards can discharge without detection. Although this product features patented or proprietary protection circuitry, damage may occur on devices subjected to high energy ESD. Therefore, proper ESD precautions should be taken to avoid performance degradation or loss of functionality.

TYPICAL PERFORMANCE CHARACTERISTICS

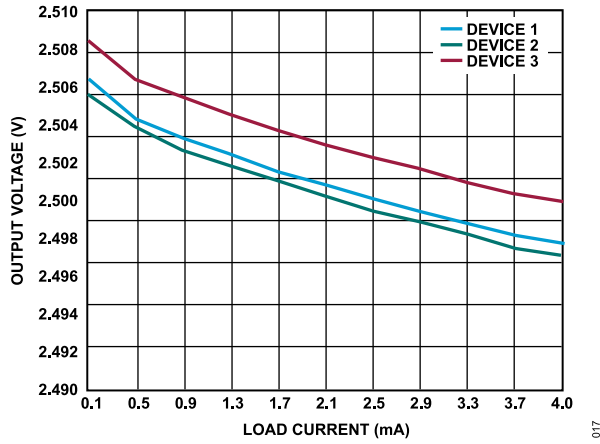

Figure 8. BUF0_VREF Load Regulation, 2.5 V Output Setting

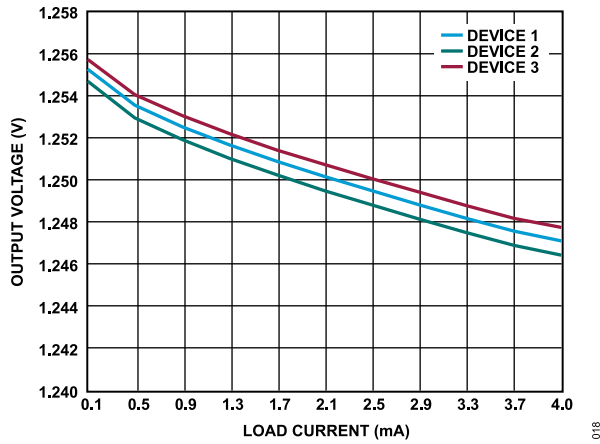

Figure 9. BUF0_VREF Load Regulation, 1.25 V Output Setting

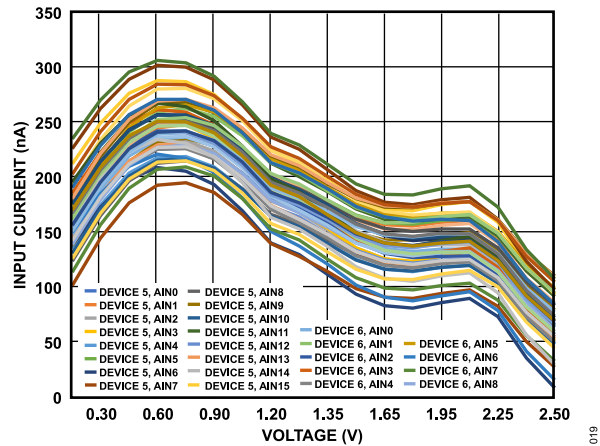

Figure 10. Input Current vs. Voltage on AINx, $f_{SAMPLE} = 2 \text{ MSPS}$

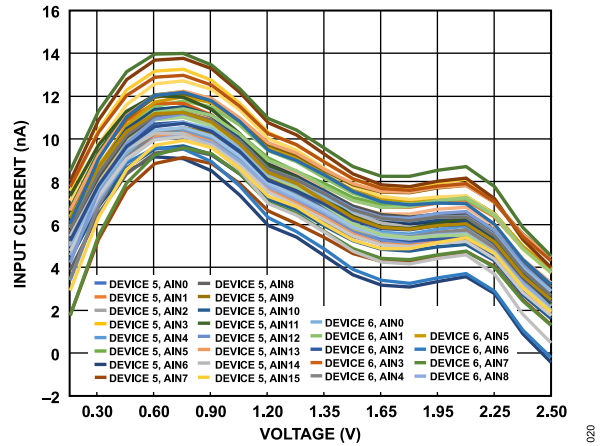

Figure 11. ADC Input Current vs. Voltage on AINx, $f_{SAMPLE} = 100 \text{ KSPS}$

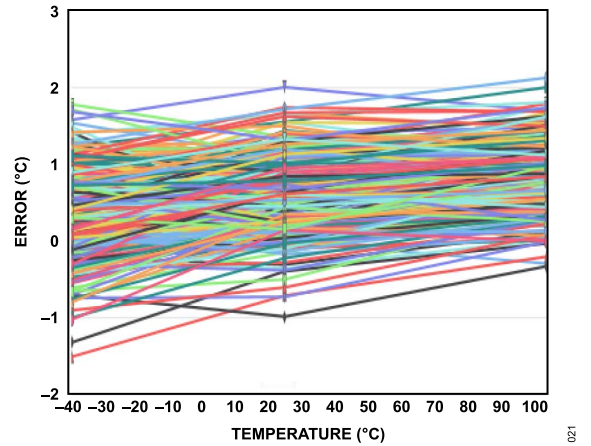

Figure 12. Temperature Sensor Accuracy, No Calibration, 240 Devices

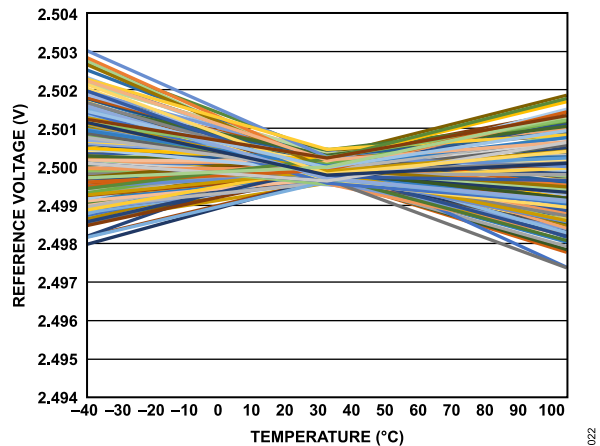

Figure 13. Reference Voltage Drift vs. Temperature, 250 Devices

PIN CONFIGURATIONS AND FUNCTION DESCRIPTIONS

	1	2	3	4	5	6	7	8	9
A	VDAC1	VDAC3/ P4.0/ PLAI11	VDAC7/ P4.2	RESET	P2.3/ BM/ PLAI10	P2.5/ MISO2/ PLAO19	P2.6/IRQ5/ SCLK2/ PLAO20	IOVDD0	IOGND
B	VREF	AIN15/ COM3N/ BUF1_VREF	VDAC6/ P4.1/ PLAO28	SWDIO	SWCLK	P2.4/ MOSI2/ PLAO18	P2.7/IRQ6/ CS2/ PLAO21	P0.4/SCL0/ SIN0/ PLAO2	P0.5/SDA0/ SOUT0/ PLAO3
C	AIN0	AIN3/ PADC1P	AIN10/ COM1P	VDAC5/ P4.4	P2.2/ POR/ CLKOUT/ SWO	P2.0/ ADCCONV/ COMPIN2/ PLAI8	P2.1/DM/ IRQ2/ ECLKIN/ COMPIN3/ PLAI9	P0.7/IRQ4/ SDA2/ COMPIN1/ PLAO5	P0.6/IRQ3/ SCL2/ COMPIN0/ PLAO4
D	AIN1	AIN2/ PADC0P	AIN11/ COM1N/ PGA0OUT	VDAC8/ P5.0	VDAC11/ P5.3	P5.6	P4.7/ IRQ7/ PLACK2	IOGND	IOVDD1
E	ADCREFN	AIN5/ PADC2P	AIN12/ COM2P	VDAC9/ P5.1	DNC	P5.5	P1.2/ SCL1/ PWM0/ PLAI6	P1.1/SOUT1/ COMOUT3/ PLAI5	P1.0/SIN1/ COMOUT2/ PLAI4
F	ADCREFP	AIN6/ PADC3P	AIN9/ COM0N/ PGA2OUT	VDAC10/ P5.2	P5.4	P4.5/PWM7	P1.3/ SDA1/ PWM1/ PLAI7	P0.1/MISO0/ COMOUT1/ PLAI1	P0.0/SCLK0/ COMOUT0/ PLAI0
G	AIN4/ PADC01N/ VDAC0	AIN14/ COM3P/ BUF0_VREF	AIN8/ COM0P	P3.2/ PRTADDR2/ PWMTRIP/ PLAI14	P3.3/ PRTADDR3/ SIN0/ PLAI15	P4.3/PWM6	P1.4/ SCL1/ PWM2/ PLAO10	P0.3/IRQ0/ CS0/ PLACK0/ PLAI3	P0.2/MOSI0/ PLACK1/ PLAI2
H	AIN7/ PADC23N/ VDAC2	AIN13/ COM2N	AGND	P3.1/ PRTADDR1/ PWMSYNC/ PLAI13	P3.4/ IRQ3/ PRTADDR4/ SOUT0/ PLAO26	P3.7/ PLAO29	P1.5/ MISO1/ PWM3/ PLAO11	DGND	DVDD
J	VDAC4	AVDD_REG	AVDD	P3.0/ IRQ8/ PRTADDR0/ SRDY0/ PLAI12	P3.5/ MCK/ SRDY1/ PLAO27	P3.6/ MDIO/ SRDY2/ PLAO30	P1.6/ MOSI1/ PWM4/ PLAO12	P1.7/IRQ1/ CS1/ PWM5/ PLAO13	DVDD_REG

DNC = DO NOT CONNECT. KEEP THIS PIN FLOATING.

009

Figure 14. 81-Ball CSP_BGA Pin Configuration

Table 12. 81-Ball CSP_BGA Pin Configuration Descriptions

Ball No.	Mnemonic	Type ¹	Description
A1	VDAC1	AO	Voltage DAC 1 Output.
A2	VDAC3/P4.0/PLAI11	AO/I/O	Voltage DAC 3 Output (VDAC3). Digital Input/Output Port 4.0 (P4.0). Input to PLA Element 11 (PLAI11).
A3	VDAC7/P4.2	AO/I/O	Voltage DAC 7 Output (VDAC7). Digital Input/Output Port 4.2 (P4.2).
A4	RESET	I	Reset Input (Active Low). An internal pull-up resistor is included with this pin.
A5	P2.3/BM/PLAI10	I/O	Digital Input/Output Port 2.3 (P2.3). An internal pull-up resistor is enabled at power-up on P2.3. Boot Mode (BM). This pin determines the start-up sequence after every reset. Input to PLA Element 10 (PLAI10).
A6	P2.5/MISO2/PLAO19	I/O	Digital Input/Output Port 2.5 (P2.5). SPI Channel 2 (SPI2) Master Input, Slave Output (MISO2). Output of PLA Element 19 (PLAO19).
A7	P2.6/IRQ5/SCLK2/PLAO20	I/O	Digital Input/Output Port 2.6 (P2.6). External Interrupt 5 (IRQ5). SPI2 Clock (SCLK2). Output of PLA Element 20 (PLAO20).
A8	IOVDD0	S	3.3 V GPIO Supply.
A9	IOGND	S	Ground for Digital Inputs/Outputs.
B1	VREF	AO/AI	0.92 V Reference with a 100 nF Capacitor.
B2	AIN15/COM3N/BUF1_VREF	A/AO	Analog Input 15 (AIN15). Comparator 3 Negative Input (COM3N). Buffered Reference Voltage Source (BUF1_VREF).
B3	VDAC6/P4.1/PLAO28	AO/I/O	Voltage DAC 6 Output (VDAC6).

PIN CONFIGURATIONS AND FUNCTION DESCRIPTIONS

Table 12. 81-Ball CSP_BGA Pin Configuration Descriptions

Ball No.	Mnemonic	Type ¹	Description
B4	SWDIO	I/O	Digital Input/Output Port 4.1 (P4.1). Output of PLA Element 2 (PLAO28).
B5	SWCLK	I	Serial Wire Bidirectional Data.
B6	P2.4/MOSI2/PLAO18	I/O	Serial Wire Debug Clock.
B7	P2.7/IRQ6/ $\overline{CS2}$ /PLAO21	I/O	Digital Input/Output Port 2.4 (P2.4). SPI2 Master Output, Slave Input (MOSI2). Output of PLA Element 18 (PLAO18).
B8	P0.4/SCL0/SIN0/PLAO2	I/O	Digital Input/Output Port 2.7 (P2.7). External Interrupt 6 (IRQ6). SPI2 Chip Select ($\overline{CS2}$). Active low. Output of PLA Element 21 (PLAO21).
B9	P0.5/SDA0/SOUT0/PLAO3	I/O	Digital Input/Output Port 0.4 (P0.4). I ² C Channel 0 (I ² C0) Serial Clock (SCL0). UART Channel 0 (UART0) Input (SIN0). Output of PLA Element 2 (PLAO2).
C1	AIN0	AI	Digital Input/Output Port 0.5 (P0.5). I ² C0 Serial Data (SDA0). UART0 Output (SOUT0). Output of PLA Element 3 (PLAO3).
C2	AIN3/PADC1P	AI	Analog Input 0.
C3	AIN10/COM1P	AI	Analog Input 3 (AIN3). PGA Channel 1 Positive Input(PADC1P).
C4	VDAC5/P4.4	AO	Analog Input 10 (AIN10). Comparator 1 Positive input (COM1P).
C5	P2.2/POR/CLKOUT/SWO	I/O	Voltage DAC 5 Output (VDAC5). Digital Input/Output Port 4.4 (P4.4).
C6	P2.0/ADCCONV/COMPIN2/PLAI8	I/O	Digital Input/Output Port 2.2 (P2.2). Reset Output (POR). This pin function is an output and it is the default. Clock Output (CLKOUT). Serial Wire Debug Output (SWO).
C7	P2.1/DM/IRQ2/ECLKIN/COMPIN3/PLAI9	I/O	Digital Input/Output Port 2.0 (P2.0). External Input to Start ADC Conversions (ADCCONV). Comparator 2 Digital Input for Three-State (COMPIN2). Input to PLA Element 8 (PLAI8).
C8	P0.7/IRQ4/SDA2/COMPIN1/PLAO5	I/O	Digital Input/Output Port 2.1 (P2.1). Download Mode Selection (DM). External Interrupt 2 (IRQ2). External Input Clock (ECLKIN). Comparator 3 Digital Input for Three-State (COMPIN3). Input to PLA Element 9 (PLAI9).
C9	P0.6/IRQ3/SCL2/COMPIN0/PLAO4	I/O	Digital Input/Output Port 0.7 (P0.7). External Interrupt 4 (IRQ4). I ² C Channel 2 (I ² C2) Serial Data (SDA2). Comparator 1 Digital Input for Three-State (COMPIN1). Output of PLA Element 5 (PLAO5).
			Digital Input/Output Port 0.6 (P0.6). External Interrupt 3 (IRQ3). I ² C2 Serial Clock (SCL2). Comparator 0 Digital Input for Three-State (COMPIN0).

PIN CONFIGURATIONS AND FUNCTION DESCRIPTIONS

Table 12. 81-Ball CSP_BGA Pin Configuration Descriptions

Ball No.	Mnemonic	Type ¹	Description
			Output of PLA Element 4 (PLA04).
D1	AIN1	AI	Analog Input 1.
D2	AIN2/PADC0P	AI	Analog Input 2 (AIN2). PGA Channel 0 Positive (PADC0P).
D3	AIN11/COM1N/PGA0OUT	AO/AI	Analog Input 11 (AIN11). Comparator 1 Negative Input (COM1N). PGA Channel 0 Output (PGA0OUT).
D4	VDAC8/P5.0	AO/I/O	Voltage DAC 8 Output (VDAC8). Digital Input/Output Port 5.0 (P5.0).
D5	VDAC11/P5.3	AO/I/O	Voltage DAC 11 Output (VDAC11). Digital Input/Output Port 5.1 (P5.3).
D6	P5.6	I/O	Digital Input/Output Port 5.6.
D7	P4.7/IRQ7/PLACLK2	I/O	Digital Input/Output Port 4.7 (P4.7). External Interrupt 7 (IRQ7). PLA Input Clock 2 (PLACLK2).
D8	IOGND	S	Ground for Digital Inputs/Outputs.
D9	IOVDD1	S	1.2 V/1.8 V GPIO Supply. If unused, IOVDD1 can be tied to DVDD_REG or to DGND.
E1	ADCREFN	AO/AI	Decoupling Capacitor Connection for ADC Reference Buffer. Connect this pin to AGND.
E2	AIN5/PADC2P	AI	Analog Input 5 (AIN5). PGA Channel 2 Positive Input (PADC2P).
E3	AIN12/COM2P	AI	Analog Input 12 (AIN12). Comparator 2 Positive Input (COM2P).
E4	VDAC9/P5.1	AO/I/O	Voltage DAC 9 Output (VDAC9). Digital Input/Output Port 5.1 (P5.1).
E5	DNC		Do Not Connect. Keep this pin floating.
E6	P5.5	I/O	Digital Input/Output Port 5.5.
E7	P1.2/SCL1/PWM0/PLAI6	I/O	Digital Input/Output Port 1.2 (P1.2). I ² C Channel 1 (I ² C1) Serial Clock (SCL1). PWM Output 0 (PWM0). Input to PLA Element 6 (PLAI6). Ball E7 is a multilevel voltage input/output with 3.3 V, 1.8 V, or 1.2 V support. Note that 3.3 V is the default.
E8	P1.1/SOUT1/COMOUT3/PLAI5	I/O	Digital Input/Output Port 1.1 (P1.1). UART1 Output (SOUT1). Comparator 3 Output (COMOUT3). Input to PLA Element 5 (PLAI5). Ball E8 is a multilevel voltage input/output with 3.3 V, 1.8 V, or 1.2 V support. Note that 3.3 V is the default.
E9	P1.0/SIN1/COMOUT2/PLAI4	I/O	Digital Input/Output Port 1.0 (P1.0). UART1 Input (SIN1). Comparator 2 Output (COMOUT2). Input to PLA Element 4 (PLAI4). Ball E9 is a multilevel voltage input/output with 3.3 V, 1.8 V, or 1.2 V support. Note that 3.3 V is the default.
F1	ADCREFP	AO/AI	Decoupling Capacitor Connection for ADC Reference Buffer with 4.7 μ F Decoupling Capacitor.
F2	AIN6/PADC3P	AI	Analog Input 6 (AIN6). PGA Channel 3 Positive Input (PADC3P).
F3	AIN9/COM0N/PGA2OUT	AO/AI	Analog Input 9 (AIN9).

PIN CONFIGURATIONS AND FUNCTION DESCRIPTIONS

Table 12. 81-Ball CSP_BGA Pin Configuration Descriptions

Ball No.	Mnemonic	Type ¹	Description
F4	VDAC10/P5.2	AO/I/O	Comparator 0 Negative Input (COM0N). PGA Channel 2 Output (PGA2OUT). Voltage DAC 10 Output (VDAC10). Digital Input/Output Port 5.2 (P5.2).
F5	P5.4	I/O	Digital Input/Output Port 5.4.
F6	P4.5/PWM7	I/O	Digital Input/Output Port 4.5 (P4.5). PWM Output 7 (PWM7).
F7	P1.3/SDA1/PWM1/PLAI7	I/O	Digital Input/Output Port 1.3 (P1.3). I ² C1 Serial Data (SDA1). PWM Output 1 (PWM1). Input to PLA Element 7 (PLAI7). Ball F7 is a multilevel voltage input/output with 3.3 V, 1.8 V, or 1.2 V support. Note that 3.3 V is the default.
F8	P0.1/MISO0/COMOUT1/PLAI1	I/O	Digital Input/Output Port 0.1 (P0.1). SPI Channel 0 (SPI0) Master Input, Slave Output (MISO0). Comparator 1 Output (COMOUT1). Input to PLA Element 1 (PLAI1). Ball F8 is a multilevel voltage input/output with 3.3 V, 1.8 V, or 1.2 V support. Note that 3.3 V is the default.
F9	P0.0/SCLK0/COMOUT0/PLAI0	I/O	Digital Input/Output Port 0.0 (P0.0). SPI0 Clock (SCLK0). Comparator 0 Output (COMOUT0). Input to PLA Element 0 (PLAI0). Ball F9 is a multilevel voltage input/output with 3.3 V, 1.8 V, or 1.2 V support. Note that 3.3 V is the default.
G1	AIN4/PADC01N/VDAC0	AI/AO	Analog Input 4 (AIN4). PGA Channel 0/PGA Channel 1 Negative Input (PADC01N). Voltage DAC 0 Output (VDAC0).
G2	AIN14/COM3P/BUF0_VREF	AI/AO	Analog Input 14 (AIN14). Comparator 3 Positive Input (COM3P). Buffered Reference Voltage Source (BUF0_VREF).
G3	AIN8/COM0P	AI	Analog Input 8 (AIN8). Comparator 0 Positive Input (COM0P).
G4	P3.2/PRTADDR2/PWMTRIP/PLAI14	I/O	Digital Input/Output Port 3.2 (P3.2). MDIO Port Address Bit 2 (PRTADDR2). PWM Trip (PWMTRIP). Input to PLA Element 14 (PLAI14).
G5	P3.3/PRTADDR3/SIN0/PLAI15	I/O	Digital Input/Output Port 3.3 (P3.3). MDIO Port Address Bit 3 (PRTADDR3). UART0 Input (SIN0). Input of PLA Element 15 (PLAI15).
G6	P4.3/PWM6	I/O	Digital Input/Output Port 4.3 (P4.3). PWM Output 6 (PWM6).
G7	P1.4/SCLK1/PWM2/PLAO10	I/O	Digital Input/Output Port 1.4 (P1.4). SPI Channel 1 (SPI1) Clock (SCLK1). PWM Output 2 (PWM2). Output of PLA Element 10 (PLAO10). Ball G7 is a multilevel voltage input/output with 3.3 V, 1.8 V, or 1.2 V support. Note that 3.3 V is the default.

PIN CONFIGURATIONS AND FUNCTION DESCRIPTIONS

Table 12. 81-Ball CSP_BGA Pin Configuration Descriptions

Ball No.	Mnemonic	Type ¹	Description
G8	P0.3/IRQ0/CS0/PLACLK0/PLAI3	I/O	Digital Input/Output Port 0.3 (P0.3). External Interrupt 0 (IRQ0). SPI0 Chip Select (CS0). Active low. PLA Clock 0 (PLACLK0). Input to PLA Element 3 (PLAI3). Ball G8 is a multilevel voltage input/output with 3.3 V, 1.8 V, or 1.2 V support. Note that 3.3 V is the default.
G9	P0.2/MOSI0/PLACLK1/PLAI2	I/O	Digital Input/Output Port 0.2 (P0.2). SPI0 Master Output, Slave Input (MOSI0). PLA Clock 1 (PLACLK1). Input to PLA Element 2 (PLAI2). Ball G9 is a multilevel voltage input/output with 3.3 V, 1.8 V, or 1.2 V support. Note that 3.3 V is the default.
H1	AIN7/PADC23N/VDAC2	A/AO	Analog Input 7 (AIN7). PGA Channel 2/PGA Channel 3 Negative Input (PADC23N). Voltage DAC 2 Output (VDAC2).
H2	AIN13/COM2N	AI	Analog Input 13 (AIN13). Comparator 2 Negative Input (COM2N).
H3	AGND	S	Analog Ground.
H4	P3.1/PRTADDR1/PWMSYNC/PLAI13	I/O	Digital Input/Output Port 3.1 (P3.1). MDIO Port Address Bit 1 (PRTADDR1). PWM Synchronization (PWMSYNC). Input to PLA Element 13 (PLAI13).
H5	P3.4/IRQ9/PRTADDR4/SOUT0/PLAO26	I/O	Digital Input/Output Port 3.4 (P3.4). External Interrupt 9 (IRQ9). MDIO Port Address Bit 4 (PRTDR4). UART0 Output (SOUT0). Output of PLA Element 26 (PLAO26).
H6	P3.7/PLAO29	I/O	Digital Input/Output Port 3.7 (P3.7). Output of PLA Element 29 (PLAO29).
H7	P1.5/MISO1/PWM3/PLAO11	I/O	Digital Input/Output Port 1.5 (P1.5). SPI1 Master Input, Slave Output (MISO1). PWM Output 3 (PWM3). Output of PLA Element 11 (PLAO11). Ball H7 is a multilevel voltage input/output with 3.3 V, 1.8 V, or 1.2 V support. Note that 3.3 V is the default.
H8	DGND	S	Digital Ground.
H9	DVDD	S	1.8 V/3.3 V Digital Power Supply.
J1	VDAC4	AO	Voltage DAC 4 Output.
J2	AVDD_REG	AO	2.5 V Analog Regulator Supply with 0.47 μ F Decoupling Capacitor. Do not use AVDD_REG to power external circuits.
J3	AVDD	S	3.3 V Analog Power Supply.
J4	P3.0/IRQ8/PRTADDR0/SRDY0/PLAI12	I/O	Digital Input/Output Port 3.0 (P3.0). External Interrupt 8 (IRQ8). MDIO Port Address Bit 0 (PRTADDR0). SPI0 Ready (SRDY0). Input to PLA Element 12 (PLAI12).
J5	P3.5/MCK/SRDY1/PLAO27	I/O	Digital Input/Output Port 3.5 (P3.5). MDIO Slave Clock (MCK).

PIN CONFIGURATIONS AND FUNCTION DESCRIPTIONS

Table 12. 81-Ball CSP_BGA Pin Configuration Descriptions

Ball No.	Mnemonic	Type ¹	Description
J6	P3.6/MDIO/SRDY2/PLAO30	I/O	SPI1 Ready (SRDY1). Output of PLA Element 27 (PLAO27). Digital Input/Output Port 3.6 (P3.6). MDIO Slave Data (MDIO). SPI2 Ready (SRDY2).
J7	P1.6/MOSI1/PWM4/PLAO12	I/O	Output of PLA Element 30 (PLAO30). Digital Input/Output Port 1.6 (P1.6). SPI1 Master Output, Slave Input (MOSI1). PWM Output 4 (PWM4). Output of PLA Element 12 (PLAO12). Ball J7 is a multilevel voltage input/output with 3.3 V, 1.8 V, or 1.2 V support. Note that 3.3 V is the default.
J8	P1.7/IRQ1/ $\overline{CS1}$ /PWM5/PLAO13	I/O	Digital Input/Output Port 1.7 (P1.7). External Interrupt 1 (IRQ1). SPI1 Chip Select ($\overline{CS1}$). Active low. PWM Output 5 (PWM5). Output of PLA Element 13 (PLAO13). Ball J8 is a multilevel voltage input/output with 3.3 V, 1.8 V, or 1.2 V support. Note that 3.3 V is the default.
J9	DVDD_REG	AO	1.1 V Digital Regulator Supply with 0.47 μ F Decoupling Capacitor. Do not use DVDD_REG to power external circuits.

¹ AO is analog output, I/O is input/output, I is digital input, S is supply, and AI is analog input.

	1	2	3	4	5	6	7	8
A	IOGND	P2.0/ ADCCONV/ COMPIN2/ PLAI8	P2.1/DM/ IRQ2/ ECLKIN/ COMPIN3/ PLAI9	SWDIO	VDAC7	VDAC6	VDAC5	VDAC3
B	P0.3/IRQ0/ $\overline{CS0}$ / PLACLK0/ PLAI3	P0.2/MOSI0/ PLACLK1/ PLAI2	P2.3/ BM PLAI10	SWCLK	\overline{RESET}	VDAC1	VREF	AVDD
C	IOVDD1	P0.1/MISO0/ COMOUT1/ PLAI1	P0.0/SCLK0/ COMOUT0/ PLAI0	P1.0/SIN1/ COMOUT2/ PLAI4	P2.2/ POR/ CLKOUT/ SWO	AIN14/ COM3P/ BUF0_VREF	AIN2/ PADC0P	AIN4/ PADC01N/ VDAC0
D	DVDD_REG	DGND	P1.2/ SCL1/ PWM0/ PLAI6	P1.3/ SDA1/ PWM1/ PLAI7	P1.1/ SOUT1/ COMOUT3/ PLAI5	AIN3/ PADC1P	AIN0	AIN10/ COM1P
E	IOVDD0	IOGND	P1.4/ SCLK1/ PWM2/ PLAO10	P1.7/ IRQ1/ $\overline{CS1}$ / PWM5/ PLAO13	VDAC8/ P5.0	AIN12/ COM2P	AGND	AVDD_REG
F	P1.5/ MISO1/ PWM3/ PLAO11	P1.6/ MOSI1/ PWM4/ PLAO12	P0.7/IRQ4/ SDA2/ COMPIN1/ PLAO5	P3.2/ PRTADDR2/ PWMTRIP/ PLAI14	VDAC9/ P5.1	AIN8/ COM0P	ADCREFN	ADCREFP
G	P0.4/SCL0/ SIN0/ PLAO2	P0.5/SDA0/ SOUT0/ PLAO3	P0.6/IRQ3/ SCL2/ COMPIN0/ PLAO4	P3.1/ PRTADDR1/ PWMSYNC/ PLAI13	VDAC11/ P5.3	AIN7/ PADC23N/ VDAC2	AIN1	AIN9/ COM0N
H	IOGND	DVDD	P3.6/ MDIO	P3.5/ MCK/ SRDY1/ PLAO27	P3.0/ PRTADDR0/ SRDY0/ PLAI12	VDAC10/ P5.2	VDAC4	AIN13/ COM2N

Figure 15. 64-Ball WLCSP Pin Configuration

Table 13. 64-Ball WLCSP Pin Function Descriptions

Pin No.	Mnemonic	Type ¹	Description
A1	IOGND	S	Ground for Digital Inputs/Outputs.
A2	P2.0/ADCCONV/COMPIN2/PLAI8	I/O	Digital Input/Output Port 2.0 (P2.0).

PIN CONFIGURATIONS AND FUNCTION DESCRIPTIONS

Table 13. 64-Ball WLCSP Pin Function Descriptions

Pin No.	Mnemonic	Type ¹	Description
A3	P2.1/DM/IRQ2/ECLKIN/COMP3IN3/PLAI9	I/O	External Input to Start ADC Conversions (ADCCONV). Comparator 2 Digital Input for Three-State (COMP2IN2). Input to PLA Element 8 (PLAI8). Digital I/O Port 2.1 (P2.1). Download Mode Selection (DM). External Interrupt 2 (IRQ2). External Input Clock (ECLKIN). Comparator 3 Digital Input for Three-State (COMP3IN3). Input to PLA Element 9 (PLAI9).
A4	SWDIO	I/O	Serial Wire Bidirectional Data.
A5	VDAC7	AO	Voltage DAC 7 Output.
A6	VDAC6	AO	Voltage DAC 6 Output.
A7	VDAC5	AO	Voltage DAC 5 Output.
A8	VDAC3	AO	Voltage DAC 3 Output.
B1	P0.3/IRQ0/ $\overline{CS0}$ /PLACK0/PLAI3	I/O	Digital Input/Output Port 0.3 (P0.3). External Interrupt 0 (IRQ0). SPI0 Chip Select ($\overline{CS0}$). PLA Clock 0 (PLACK0). Input to PLA Element 3 (PLAI3). Ball B1 is a multilevel voltage input/output with 3.3 V, 1.8 V, or 1.2 V support. Note that 3.3 V is the default.
B2	P0.2/MOSI0/PLACK1/PLAI2	I/O	Digital Input/Output Port 0.2 (P0.2). SPI0 Master Out, Slave In (MOSI0). PLA Clock 1 (PLACK1). Input to PLA Element 2 (PLAI2). Ball B2 is a multilevel voltage input/output with 3.3 V, 1.8 V, or 1.2 V support. Note that 3.3 V is the default.
B3	P2.3/BM/PLAI10	I/O	Digital Input/Output Port 2.3 (P2.3). An internal pull-up resistor is enabled at power-up on P2.3. Boot Mode (BM). This pin determines the start-up sequence after every reset. Input to PLA Element 10 (PLAI10).
B4	SWCLK	I	Serial Wire Debug Clock.
B5	RESET	I	Reset Input (Active Low). An internal pull-up resistor is included with this pin.
B6	VDAC1	AO	Voltage DAC 1 Output.
B7	VREF	AO/AI	0.92 V Reference with a 100 nF Capacitor.
B8	AVDD	S	3.3 V Analog Power Supply.
C1	IOVDD1	S	1.2 V/1.8 V GPIO Supply. If unused, IOVDD1 can be tied to DVDD_REG or to DGND.
C2	P0.1/MISO0/COMOUT1/PLAI1	I/O	Digital Input/Output Port 0.1 (P0.1). SPI 0 Master Input, Slave Output (MISO0). Comparator 1 Output (COMOUT1) Input to PLA Element 1 (PLAI1). Ball C2 is a multilevel voltage input/output with 3.3 V, 1.8 V, or 1.2 V support. Note that 3.3 V is the default.
C3	P0.0/SCLK0/COMOUT0/PLAI0	I/O	Digital Input/Output Port 0.0 (P0.0). SPI 0 Clock (SCLK0). Comparator 0 Output (COMOUT0). Input to PLA Element 0 (PLAI0). Ball C3 is a multilevel voltage input/output with 3.3 V, 1.8 V, or 1.2 V support. Note that 3.3 V is the default.

PIN CONFIGURATIONS AND FUNCTION DESCRIPTIONS

Table 13. 64-Ball WLCSP Pin Function Descriptions

Pin No.	Mnemonic	Type ¹	Description
C4	P1.0/SIN1/COMOUT2/PLAI4	I/O	Digital Input/Output Port 1.0 (P1.0). UART Input 1 (SIN1). Comparator 2 Output (COMOUT2). Input to PLA Element 4 (PLAI4). Ball C4 is a multilevel voltage input/output with 3.3 V, 1.8 V, or 1.2 V support. Note that 3.3 V is the default.
C5	P2.2/POR/CLKOUT/SWO	I/O	Digital Input/Output Port 2.2 (P2.2). Reset Output (POR). This pin function is an output, and it is the default. Clock Output (CLKOUT). Serial Wire Debug (SWD) Output (SWO).
C6	AIN14/COM3P/BUF0_VREF	AI/AO	Analog Input 14 (AIN14). Comparator 3 Positive Input (COM3P). Buffered Reference Voltage source (BUF0_VREF).
C7	AIN2/PADC0P	AI	Analog Input 2 (AIN2). PGA Channel 0 Positive (PADC0P).
C8	AIN4/PADC01N/VDAC0	AI/AO	Analog Input 4 (AIN4). PGA Channel 0/PGA Channel 1 Negative Input (PADC01N). Voltage DAC 0 Output (VDAC0).
D1	DVDD_REG	AO	1.1 V Digital Regulator Supply with 0.47 μ F Decoupling Capacitor. Do not use DVDD_REG to power external circuits.
D2	DGND	S	Digital Ground.
D3	P1.2/SCL1/PWM0/PLAI6	I/O	Digital Input/Output Port 1.2 (P1.2). I ² C1 Serial Clock (SCL1). PWM Output 0 (PWM0). Input to PLA Element 6 (PLAI6). Ball D3 is a multilevel voltage input/output with 3.3 V, 1.8 V, or 1.2 V support. Note that 3.3 V is the default.
D4	P1.3/SDA1/PWM1/PLAI7	I/O	Digital Input/Output Port 1.3 (P1.3). I ² C1 Serial Data (SDA1). PWM Output 1 (PWM1). Input to PLA Element 7 (PLAI7). Ball D4 is a multilevel voltage input/output with 3.3 V, 1.8 V, or 1.2 V support. Note that 3.3 V is the default.
D5	P1.1/SOUT1/COMOUT3/PLAI5	I/O	Digital Input/Output Port 1.1 (P1.1). UART Channel 1 (UART1) Output (SOUT1). Comparator 3 Output (COMOUT3). Input to PLA Element 5 (PLAI5). Ball D5 is a multilevel voltage input/output with 3.3 V, 1.8 V, or 1.2 V support. Note that 3.3 V is the default.
D6	AIN3/PADC1P	AI	Analog Input 3 (AIN3). PGA Channel 1 Positive Input (PADC1P).
D7	AIN0	AI	Analog Input 0.
D8	AIN10/COM1P	AI	Analog Input 10 (AIN10). Comparator 1 Positive Input (COM1P).
E1	IOVDD0	S	3.3 V GPIO Supply.
E2	IOGND	S	Ground for Digital Inputs/Outputs.
E3	P1.4/SCLK1/PWM2/PLAO10	I/O	Digital Input/Output Port 1.4 (P1.4). SPI1 Clock (SCLK1). PWM Output 2 (PWM2).

PIN CONFIGURATIONS AND FUNCTION DESCRIPTIONS

Table 13. 64-Ball WLCSP Pin Function Descriptions

Pin No.	Mnemonic	Type ¹	Description
E4	P1.7/IRQ1/ $\overline{CS1}$ /PWM5/PLAO13	I/O	Output of PLA Element 10 (PLAO10). Ball E3 is a multilevel voltage input/output with 3.3 V, 1.8 V, or 1.2 V support. Note that 3.3 V is the default. Digital Input/Output Port 1.7 (P1.7). External Interrupt 1 (IRQ1). SPI1 Chip Select ($\overline{CS1}$). PWM Output 5 (PWM5). Output of PLA Element 13 (PLAO13). Ball E4 is a multilevel voltage input/output with 3.3 V, 1.8 V, or 1.2 V support. Note that 3.3 V is the default.
E5	VDAC8/P5.0	AO/I/O	Voltage DAC 8 Output (VDAC8). Digital Input/Output Port 5.0 (P5.0).
E6	AIN12/COM2P	AI	Analog Input 12 (AIN12). Comparator 2 Positive Input (COM2P).
E7	AGND	S	Analog Ground.
E8	AVDD_REG	AO	2.5 V Analog Regulator Supply with 0.47 μ F Decoupling Capacitor. Do not use AVDD_REG to power external circuits.
F1	P1.5/MISO1/PWM3/PLAO11	I/O	Digital Input/Output Port 1.5 (P1.5). SPI1 Master Input, Slave Output (MISO1). PWM Output 3 (PWM3). Output of PLA Element 11 (PLAO11). Ball F1 is a multilevel voltage input/output with 3.3 V, 1.8 V, or 1.2 V support. Note that 3.3 V is the default.
F2	P1.6/MOS11/PWM4/PLAO12	I/O	Digital Input/Output Port 1.6 (P1.6). SPI1 Master Out, Slave Input (MOS11). PWM Output 4 (PWM4). Output of PLA Element 12 (PLAO12). Ball F2 is a multilevel voltage input/output with 3.3 V, 1.8 V, or 1.2 V support. Note that 3.3 V is the default.
F3	P0.7/IRQ4/SDA2/COMPIN1/PLAO5	I/O	Digital Input/Output Port 0.7 (P0.7). External Interrupt 4 (IRQ4). I ² C2 Serial Data (SDA2). Comparator 1 Digital Input for Three-State (COMPIN1). Output of PLA Element 5 (PLAO5).
F4	P3.2/PRTADDR2/PWMTRIP/PLA14	I/O	Digital Input/Output Port 3.2 (P3.2). MDIO Port Address Bit 2 (PRTADDR2). PWM Trip (PWMTRIP). Input to PLA Element 14 (PLA14).
F5	VDAC9/P5.1	AO/I/O	Voltage DAC 9 Output (VDAC9). Digital Input/Output Port 5.1 (P5.1).
F6	AIN8/COM0P	AI	Analog Input 8 (AIN8). Comparator 0 Positive Input (COM0P).
F7	ADCREFN	AO/AI	Decoupling Capacitor Connection for ADC. Connect ADCREFN to AGND.
F8	ADCREFP	AO/AI	Decoupling Capacitor Connection for ADC Reference Buffer with 4.7 μ F Decoupling Capacitor.
G1	P0.4/SCL0/SIN0/PLAO2	I/O	Digital Input/Output Port 0.4 (P0.4). I ² C0 Serial Clock (SCL0). UART0 Input (SIN0). Output of PLA Element 2 (PLAO2).
G2	P0.5/SDA0/SOUT0/PLAO3	I/O	Digital Input/Output Port 0.5 (P0.5).

PIN CONFIGURATIONS AND FUNCTION DESCRIPTIONS

Table 13. 64-Ball WLCSP Pin Function Descriptions

Pin No.	Mnemonic	Type ¹	Description
G3	P0.6/IRQ3/SCL2/COMPDI0/PLAO4	I/O	I ² C0 Serial Data (SDA0). UART0 Output (SOUT0). Output of PLA Element 3 (PLAO3). Digital Input/Output Port 0.6 (P0.6). External Interrupt 3 (IRQ3). I ² C2 Serial Clock (SCL2). Comparator 0 Digital Input for Three-State (COMPDI0). Output of PLA Element 4 (PLAO4).
G4	P3.1/PRTADDR1/PWMSYNC/PLAI13	I/O	Digital Input/Output Port 3.1 (P3.1). MDIO Port Address Bit 1 (PRTADDR1). PWM Synchronization (PWMSYNC). Input to PLA Element 13 (PLAI13).
G5	VDAC11/P5.3	AO/I/O	Voltage DAC 11 Output (VDAC11). Digital Input/Output Port 5.1 (P5.3).
G6	AIN7/PADC23N/VDAC2	AI/AO	Analog Input 7 (AIN7). PGA Channel 2/PGA Channel 3 Negative Input (PADC23N). Voltage DAC 2 Output (VDAC2).
G7	AIN1	AI	Analog Input 1.
G8	AIN9/COM0N	AI	Analog Input 9 (AIN9). Comparator 0 Negative Input (COM0N).
H1	IOGND	S	Ground for Digital Inputs/Outputs.
H2	DVDD	S	1.8 V/3.3 V Digital Power Supply.
H3	P3.6/MDIO	I/O	Digital Input/Output Port 3.6 (P3.6). MDIO Slave Data (MDIO). See the Silicon Anomaly section.
H4	P3.5/MCK/SRDY1/PLAO27	I/O	Digital Input/Output Port 3.5 (P3.5). MDIO Slave Clock (MCK). See the Silicon Anomaly section. SPI1 Ready (SRDY1). Output of PLA Element 27 (PLAO27).
H5	P3.0/PRTADDR0/SRDY0/PLAI12	I/O	Digital Input/Output Port 3.0 (P3.0). MDIO Port Address Bit 0 (PRTADDR0). SPI 0 Ready (SRDY0). Input to PLA Element 12 (PLAI12).
H6	VDAC10/P5.2	AO/I/O	Voltage DAC 10 Output (VDAC10). Digital Input/Output Port 5.2 (P5.2).
H7	VDAC4	AO	Voltage DAC 4 Output.
H8	AIN13/COM2N	AI	Analog Input 13 (AIN13). Comparator 2 Negative Input (COM2N).

¹ S is supply, I/O is input/output, AO is analog output, I is digital input, and AI is analog input.

THEORY OF OPERATION

The ADuCM410 is an on-chip system. The ADuCM410 is mixed-signal microcontroller based on the Arm Cortex-M33 processor.

See the [ADuCM410 hardware reference manual](#) for full details on the operation of the ADuCM410, including, but not limited to,

all register details and information about the various features and operation of the power management unit, the Arm Cortex-M33 processor, the ADC circuit, the flash controller, and the SPI, I²C, and UART interfaces.

RMS NOISE RESOLUTION OF ADC

The rms noise specifications for the ADC with different ADC digital filter settings are described in [Table 14](#).

The internal 2.5 V reference was used for all measurements.

For gain = 1, single-ended measurements with $V_{IN} = 2$ V was used.

For PGA gains ≥ 2 , a differential input voltage was applied, ensuring the PGA output to the ADC was always 2 V. For example, for gain = 4, $V_{IN} = 500$ mV.

[Table 15](#) shows the rms and peak-to-peak effective number of bits based on the noise results in [Table 14](#) for various PGA gain set-

tings. Peak-to-peak effective bit results are shown in parentheses. RMS bits are calculated as follows:

$$\log\left(\frac{\text{Input Range}}{\text{RMS Noise}}\right) \quad (1)$$

Peak-to-peak bits are calculated as follows:

$$\log_2\left(\frac{\text{Input Range}}{6.6 \times \text{RMS Noise}}\right) \quad (2)$$

Table 14. ADC RMS Noise

Update Rate (Hz)	Oversampling Ratio (OSR)	RMS Noise (μ V), PGA Output Voltage = 2 V for All Settings					
		Gain = 1	Gain = 2	Gain = 4	Gain = 6	Gain = 8	Gain = 10
2,000,000	1	81.3	Not applicable	Not applicable	Not applicable	Not applicable	Not applicable
50,000	8	32.44	30.8	17.4	11.9	7.5	5.2
20,000	32	20.15	Not applicable	Not applicable	Not applicable	Not applicable	Not applicable
5000	16	Not applicable	13.4	10.0	11.5	9.96	10.78
5000	8	Not applicable	15.8	11.47	12.7	10.6	11.4

Table 15. ADC Effective Bits, Based on RMS Noise (Peak-to-Peak Effective Bits in Parenthesis)

Update Rate (Hz)	Sinc3 OSR	Gain = 1	Gain = 2	Gain = 4	Gain = 6	Gain = 8	Gain = 10
2,000,000	1	14.9 (12.18 p-p)	Not applicable	Not applicable	Not applicable	Not applicable	Not applicable
50,000	8	16 (13.5 p-p)	15.3 (12.6 p-p)	15.1 (12.4 p-p)	15.1 (12.37 p-p)	15.3 (12.6 p-p)	15.5 (12.8 p-p)
20,000	32	16 (14.19 p-p)	Not applicable	Not applicable	Not applicable	Not applicable	Not applicable
5000	16	Not applicable	16 (13.78 p-p)	15.9 (13.2 p-p)	15.15 (12.4 p-p)	14.9 (12.2 p-p)	14.5 (11.8 p-p)
5000	8	Not applicable	16 (13.54 p-p)	15.73 (13 p-p)	15 (12.27 p-p)	14.85 (12.1 p-p)	14.4 (11.7 p-p)

APPLICATIONS INFORMATION

POWER SUPPLIES

The ADuCM410 operational power supply voltage range is 2.85 V to 3.6 V for AVDD and IOVDD0. IOVDD1 can be 1.2 V, 1.8 V, or the same as IOVDD0. The DVDD range is 1.8 V to 3.6 V. Separate analog (AVDD) and digital power supply pins (IOVDD1 and DVDD) allow AVDD to be kept relatively free of noisy digital signals often present in the system DVDD line. In this mode, the ADuCM410 can also operate with split supplies. That is, the device can use different voltage levels for each supply (see Table 1). A typical split supply configuration is shown in Figure 16.

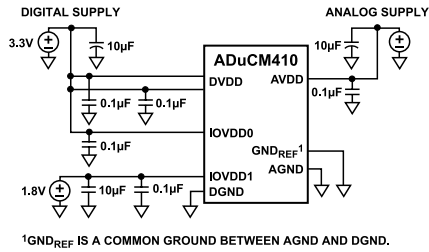

Figure 16. External Multiple Supply Connections

As an alternative to providing two separate power supplies, the user can reduce noise on AVDD by placing a small series resistor and/or ferrite bead between AVDD and DVDD, and then decoupling AVDD separately to ground. An example of this configuration is shown in Figure 17. With this configuration, other analog circuitry (such as op amps and voltage reference) can be powered from the AVDD supply line as well.

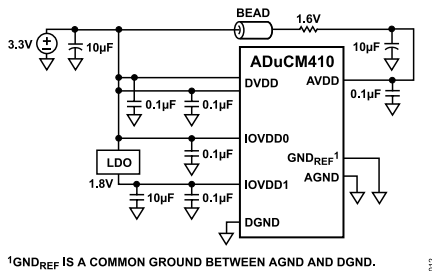

Figure 17. External Single-Supply Connections

In both Figure 16 and Figure 17, a large value (10 µF) reservoir capacitor is connected to DVDD, and a separate 10 µF capacitor is connected to AVDD. In addition, local small value (0.1 µF) capacitors are located at each AVDD, IOVDD0, IOVDD1, and DVDD pin of the chip. Include all recommended capacitors shown, and ensure that the smaller capacitors are close to each supply pin with trace lengths as short as possible. Connect the ground terminal of each of these capacitors directly to the underlying ground plane.

The analog and digital ground pins on the ADuCM410 must be referenced to the same system ground reference point.

POWER-UP REQUIREMENTS

Figure 18 and Figure 19 show the power-up requirements for DVDD and AVDD. Figure 20 shows the power-up requirement for IOVDD0 if no external pull-up is applied to the P2.3/BM/PLA110 pin.

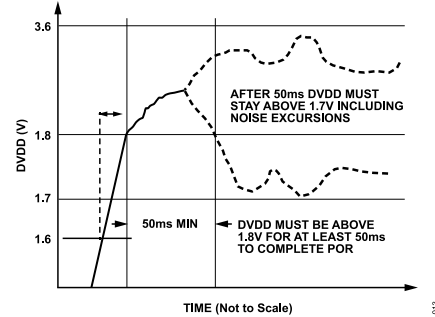

Figure 18. DVDD Power-Up Requirements

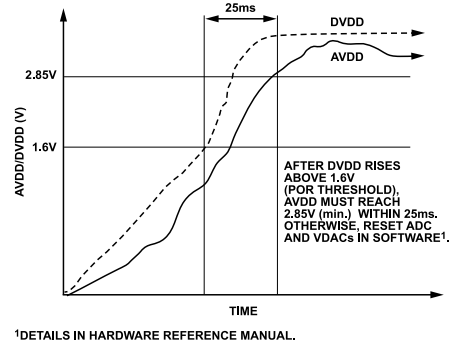

Figure 19. AVDD Power-Up Requirements

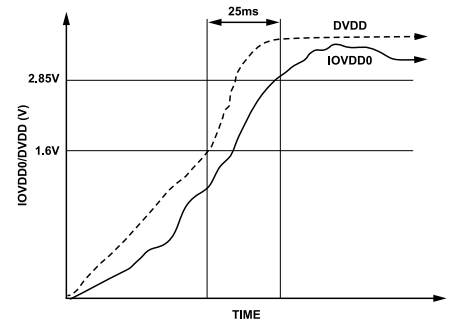

Figure 20. IOVDD0 Power-Up Requirement, No External Pull-Up

RECOMMENDED CIRCUIT AND COMPONENT VALUES

Figure 21 shows a typical connection diagram for the ADuCM410.

Adequately decouple the supplies and regulators with capacitors connected between the AVDD_REG, DVDD_REG, and IOVDDx balls and their associated ground balls (AGND and DGND). Table 12 and Table 13 indicate which ground balls are paired with which supply balls.

APPLICATIONS INFORMATION

There are three digital supply balls, IOVDD0, IOVDD1, and DVDD. Decouple these balls with a 0.1 μF capacitor placed as near as possible to each of the three balls and their associated ground balls (IOGND and DGND). In addition, place a 10 μF capacitor near these balls. For DVDD, to improve noise reduction, place a ferrite bead in series with a 10 μF capacitor to DGND.

Similarly, the analog supply pin (AVDD) requires a 0.1 μF capacitor placed as near as possible to each ball and its associated AGND ball. Also, place a 10 μF capacitor near these balls.

The ADC reference requires a 4.7 μF capacitor be placed between ADCREFP and ADCREFN and located as near as possible to each ball. ADCREFN must be connected directly to AGND. The ADuCM410 contains two internal regulators. These regulators require external decoupling capacitors. The DVDD_REG and AVDD_REG balls each require a 0.47 μF capacitor to DGND and AGND, respectively. Take care in the layout to ensure that currents flowing from the ground end of each decoupling capacitor to its associated ground ball share as little track as possible with other ground currents on the PCB.

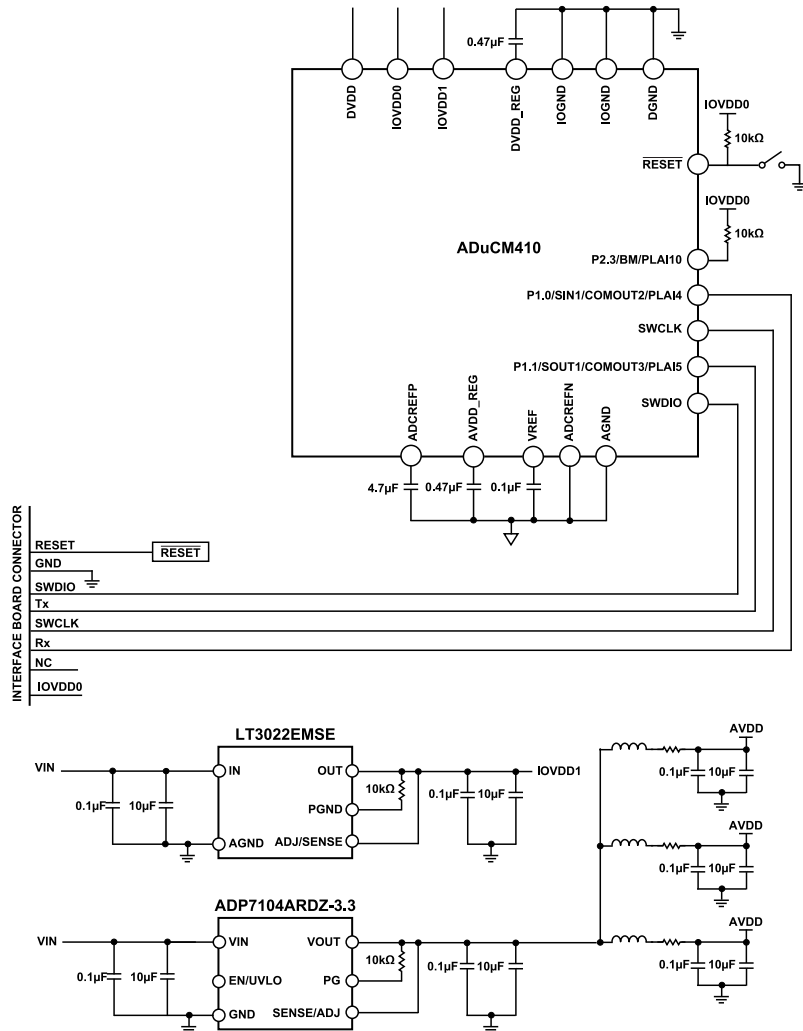

Figure 21. Recommended Circuit and Component Values (ADuCM410, LT3022EMSE, and ADP7104ARDZ-3.3)

SILICON ANOMALY

This anomaly list describes the known bugs, anomalies, and workarounds for the ADuCM410 microcontroller Revision B silicon. The anomaly listed applies to the WLCSP ADuCM410 packaged material that is branded as follows:

First Line ADuCM410
Third Line B90 or newer (revision identifier)

The anomaly does not apply to the CSP_BGA version of the ADuCM410.

Analog Devices, Inc., is committed, through future silicon revisions, to continuously improve silicon functionality. Analog Devices tries to ensure that these future silicon revisions remain compatible with your present software/systems by implementing the recommended workarounds outlined here.

ADUCM410 FUNCTIONALITY ISSUES

Silicon Revision Identifier	Kernel Revision Identifier	Chip Marking	Silicon Status	Anomaly Sheet	No. of Reported Anomalies
B	0	All silicon branded B90	Release	Rev. 0	1

FUNCTIONALITY ISSUES

Table 16. PLL Unlock Interrupt Asserted When P3.6/MDIO Pin Toggles [er001]

Background	The default system clock for the ADuCM410 is from an internal PLL. The PLL input is the internal 16 MHz oscillator. The oscillator output by default is 160 MHz and can be selected as the system clock for the memories, Cortex-M33, and other peripherals. An interrupt is provided to detect PLL lock and unlock states. If a PLL unlock interrupt is asserted, do not select the PLL output as the system clock.
Issue	When P3.6/MDIO is toggled as a GPIO pin or when used as the MDIO data I/O function, the PLL lock detection circuit can assert many PLL unlock interrupts to the Cortex-M33 core if the PLL interrupt is enabled. On the WLCSP models, the P3.6/MDIO pin is directly underneath the 16 MHz oscillator. If P3.6/MDIO toggles at frequencies >1 kHz, the oscillator output frequency can vary beyond the frequency range allowed by the PLL lock detection circuit.
Workaround	On the WLCSP models for the ADuCM410 device, do not use the MDIO feature. If using P3.6/MDIO as a digital I/O pin, its input or output frequency must be less than 1 kHz.
Related Issues	None.

SECTION 1. ADUCM410 FUNCTIONALITY ISSUES

Reference Number	Description	Status
er001	PLL unlock interrupt asserted when P3.6/MDIO pin toggles	Open

OUTLINE DIMENSIONS

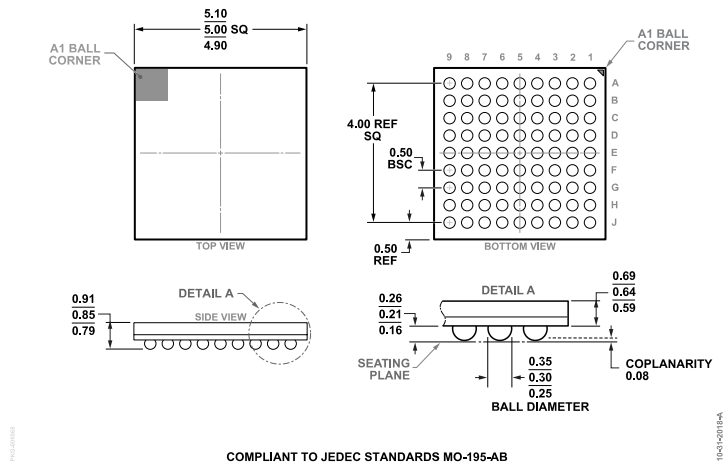

Figure 22. 81-Ball Chip Scale Package Ball Grid Array [CSP_BGA] (BC-81-6)
 Dimensions shown in millimeters

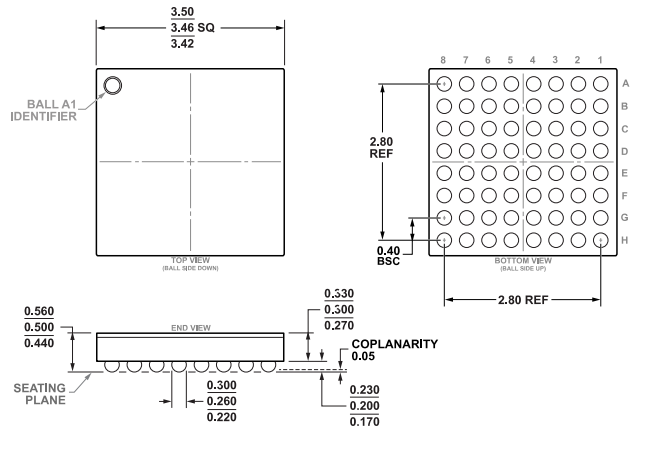

Figure 23. 64-Ball Wafer Level Chip Scale Package [WLCSP] (CB-64-2)
 Dimensions shown in millimeters

Updated: November 11, 2021

ORDERING GUIDE

Model ¹	Temperature Range	Package Description	Packing Quantity	Package Option
ADUCM410BBCZ	-40°C to +105°C	81-Ball CSP-BGA (5mm x 5mm x 0.85mm)	Tray, 640	BC-81-6
ADUCM410BBCZ-RL7	-40°C to +105°C	81-Ball CSP-BGA (5mm x 5mm x 0.85mm)	Reel, 1000	BC-81-6
ADUCM410BCBZ-RL7	-40°C to +105°C	64-Ball LFCWLCSP (3.46mm x 3.46mm x 0.5mm)	Reel, 1500	CB-64-2

¹ Z = RoHS Compliant Part.

EVALUATION BOARDS

Model ¹	Description
EVAL-ADuCM410QSPZ	CSP_BGA Evaluation Board and Quick Start Development System

OUTLINE DIMENSIONS

Model ¹	Description
EVAL-ADuCM410QSP1Z	WLCSP Evaluation Board and Quick Start Development System

¹ Z = RoHS Compliant Part.

I²C refers to a communications protocol originally developed by Philips Semiconductors (now NXP Semiconductors).

Looking for pricing, stock, or lifecycle information?

Click below to explore more details on WIN SOURCE:

 [View ADUCM410BCBZ-RL7 on WIN SOURCE](#)

 [Analog Devices Inc. Information](#)

Optimize Your Supply Chain with WIN SOURCE Solutions

-  Global Sourcing Solution
-  Obsolete Management
-  Cost Control Management
-  Shortage Management
-  Alternative Solution
-  Excess Inventory Management