



**THE DATASHEET OF
8T39210NLGI8**



Description

The 8T39210 is a high-performance clock fanout buffer. The input clock can be selected from two differential inputs or one crystal input. The internal oscillator circuit is automatically disabled if the crystal input is not selected. The crystal pin can be driven by a single-ended clock. The selected signal is distributed to ten differential outputs that can be configured as LVPECL, LVDS, or HCSL outputs. In addition, an LVCMOS output is provided. All outputs can be disabled into a high-impedance state.

The device is designed for a signal fanout of high-frequency, low phase-noise clock and data signal. The outputs are at a defined level when inputs are open or tied to ground. It is designed to operate from a 3.3V or 2.5V core power supply, and either a 3.3V or 2.5V output operating supply.

Block Diagram

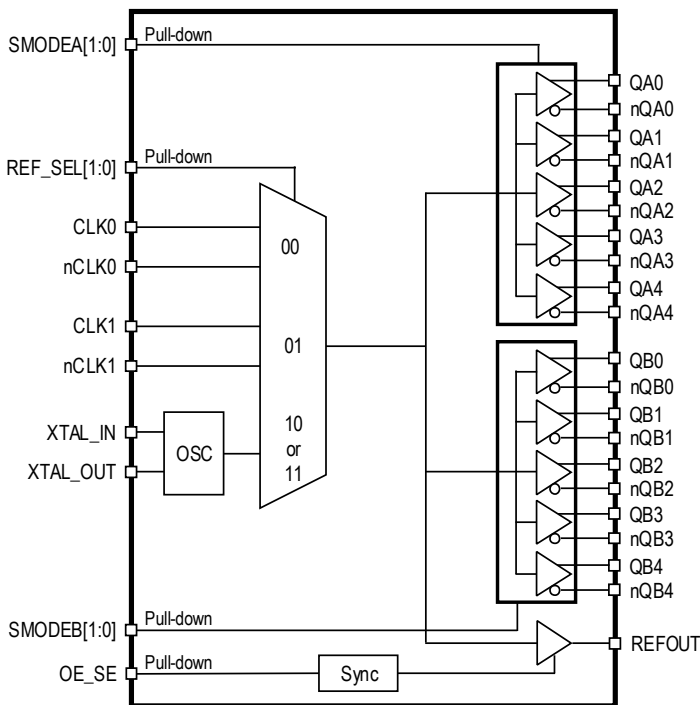

Features

- Two differential reference clock input pairs
- Differential input pairs can accept the following differential input levels: LVPECL, LVDS, HCSL, HSTL, or Single ended
- Crystal Input accepts 10MHz to 40MHz Crystal or Single-ended Clock
- Maximum Output Frequency
 - LVPECL - 1.5GHz
 - LVDS - 1.5GHz
 - HCSL - 750MHz
 - LVCMOS - 250MHz
- Two banks, each has five differential output pairs that can be configured as LVPECL, LVDS, or HCSL
- One single-ended reference output with synchronous enable to avoid clock glitch
- Output skew: 81ps (maximum)
(Bank A and Bank B at the same output level)
- Part-to-part skew: 200ps (typical)
- Additive RMS phase jitter at 156.25MHz:
37.6fs RMS (12kHz - 20MHz), typical at 3.3V/3.3V
- Supply voltage modes:
 - V_{DD}/V_{DD0}
 - 3.3V/3.3V
 - 3.3V/2.5V
 - 2.5V/2.5V
- -40°C to 85°C ambient operating temperature
- Lead-free (RoHS 6) packaging

Contents

Description	1
Block Diagram	1
Features	1
Pin Assignments	3
Pin Descriptions	3
Pin Characteristics	5
Function Tables	6
Absolute Maximum Ratings	9
Recommended Operating Conditions	9
DC Electrical Characteristics	10
AC Electrical Characteristics	14
Additive Phase Jitter	20
Applications Information	21
Recommendations for Unused Input and Output Pins	21
Inputs	21
CLK/nCLK Inputs	21
Crystal Inputs	21
LVCMOS Control Pins	21
Outputs	21
LVCMOS Output (REFOUT)	21
LVPECL and HCSL Outputs	21
LVDS Outputs	21
Differential Outputs	21
Crystal Input Interface	22
Power-up Ramp Sequence	22
Overdriving the XTAL Interface	23
Wiring the Differential Input to Accept Single-Ended Levels	24
3.3V Differential Clock Input Interface	25
2.5V Differential Clock Input Interface	26
LVDS Driver Termination	28
Termination for 3.3V LVPECL Outputs	29
Termination for 2.5V LVPECL Outputs	30
Recommended Termination	31
VFQFPN EPAD Thermal Release Path	31
LVPECL Power Considerations	32
LVPECL Power Considerations (Application Frequency 156.25MHz)	33
LVDS Power Considerations	35
LVDS Power Considerations (Application Frequency 156.25MHz)	36
HCSL Power Considerations	37
HCSL Power Considerations (Application Frequency 156.25MHz)	38
Reliability Information	39
Transistor Count	39
Package Outline Drawings	40
Ordering Information	40
Revision History	40

Pin Assignments

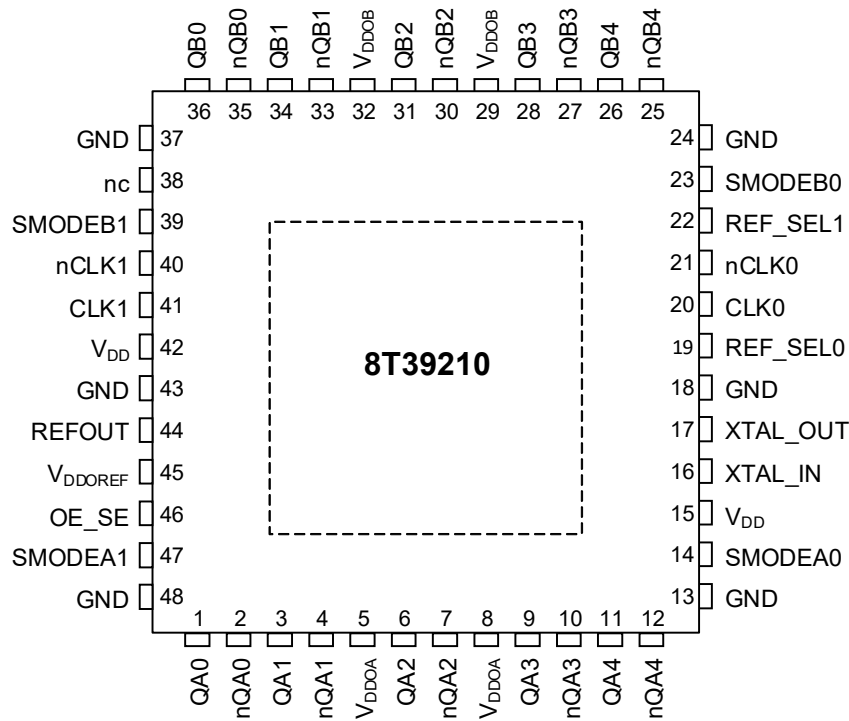

Pin Descriptions

Table 1. Pin Descriptions^[a]

Number	Name	Type		Description
1	QA0	Output		Differential Bank A clock output pair. LVPECL, LVDS or HCSL interface levels.
2	nQA0	Output		Differential Bank A clock output pair. LVPECL, LVDS or HCSL interface levels.
3	QA1	Output		Differential Bank A clock output pair. LVPECL, LVDS or HCSL interface levels.
4	nQA1	Output		Differential Bank A clock output pair. LVPECL, LVDS or HCSL interface levels.
5	V _{DD0A}	Power		Output supply pins for Bank QA outputs.
6	QA2	Output		Differential Bank A clock output pair. LVPECL, LVDS or HCSL interface levels.
7	nQA2	Output		Differential Bank A clock output pair. LVPECL, LVDS or HCSL interface levels.
8	V _{DD0A}	Power		Output supply pins for Bank QA outputs.
9	QA3	Output		Differential Bank A clock output pair. LVPECL, LVDS or HCSL interface levels.
10	nQA3	Output		Differential Bank A clock output pair. LVPECL, LVDS or HCSL interface levels.
11	QA4	Output		Differential Bank A clock output pair. LVPECL, LVDS or HCSL interface levels.
12	nQA4	Output		Differential Bank A clock output pair. LVPECL, LVDS or HCSL interface levels.
13	GND	Power		Power supply ground.
14	SMODEA0	Input	Pulldown	Output driver select for Bank A outputs. See Table 8 for function. LVCMOS/LVTTL interface levels.
15	V _{DD}	Power		Power supply pin.
16	XTAL_IN	Input		Crystal oscillator interface.

Table 1. Pin Descriptions^[a] (Cont.)

Number	Name	Type		Description
17	XTAL_OUT	Output		Crystal oscillator interface.
18	GND	Power		Power supply ground.
19	REF_SEL0	Input	Pulldown	Input clock selection. LVCMOS/LVTTL interface levels. See Table 3 for function.
20	CLK0	Input	Pullup/ Pulldown	Non-inverting differential clock. Internally biased to 0.33V _{DD} .
21	nCLK0	Input	Pullup/ Pulldown	Inverting differential clock. Internally biased to 0.4V _{DD} .
22	REF_SEL1	Input	Pulldown	Input clock selection. LVCMOS/LVTTL interface levels. See Table 3 for function.
23	SMODEB0	Input	Pulldown	Output driver select for Bank B outputs. See Table 9 for function. LVCMOS/LVTTL interface levels.
24	GND	Power		Power supply ground.
25	nQB4	Output		Differential Bank B clock output pair. LVPECL, LVDS or HCSL interface levels.
26	QB4	Output		Differential Bank B clock output pair. LVPECL, LVDS or HCSL interface levels.
27	nQB3	Output		Differential Bank B clock output pair. LVPECL, LVDS or HCSL interface levels.
28	QB3	Output		Differential Bank B clock output pair. LVPECL, LVDS or HCSL interface levels.
29	V _{DDOB}	Power		Output supply pins for Bank QB outputs.
30	nQB2	Output		Differential Bank B clock output pair. LVPECL, LVDS or HCSL interface levels.
31	QB2	Output		Differential Bank B clock output pair. LVPECL, LVDS or HCSL interface levels.
32	V _{DDOB}	Power		Output supply pins for Bank QB outputs.
33	nQB1	Output		Differential Bank B clock output pair. LVPECL, LVDS or HCSL interface levels.
34	QB1	Output		Differential Bank B clock output pair. LVPECL, LVDS or HCSL interface levels.
35	nQB0	Output		Differential Bank B clock output pair. LVPECL, LVDS or HCSL interface levels.
36	QB0	Output		Differential Bank B clock output pair. LVPECL, LVDS or HCSL interface levels.
37	GND	Power		Power supply ground.
38	nc	Unused		No connect pin.
39	SMODEB1	Input	Pulldown	Output driver select for Bank B outputs. See Table 9 for function. LVCMOS/LVTTL interface levels.
40	nCLK1	Input	Pullup/ Pulldown	Inverting differential clock. Internally biased to 0.4V _{DD} .
41	CLK1	Input	Pullup/ Pulldown	Non-inverting differential clock. Internally biased to 0.33V _{DD} .
42	V _{DD}	Power		Power supply pin.
43	GND	Power		Power supply ground.
44	REFOUT	Output		Single-ended reference clock output. LVCMOS/LVTTL interface levels.
45	V _{DDOREF}	Power		Output supply pin for REFOUT output.
46	OE_SE	Input	Pulldown	Output enable. LVCMOS/LVTTL interface levels (see Table 4).

Table 1. Pin Descriptions^[a] (Cont.)

Number	Name	Type		Description
47	SMODEA1	Input	Pulldown	Output driver select for Bank A outputs. See Table 8 for function. LVCMOS/LVTTL interface levels.
48	GND	Power		Power supply ground.
ePad	GND_EP	Power		Connect ePad to ground to ensure proper heat dissipation.

[a] *Pulldown* and *Pullup* refer to internal input resistors. See Table 2, *Pin Characteristics*, for typical values.

Pin Characteristics

Table 2. Pin Characteristics

Symbol	Parameter		Test Conditions	Minimum	Typical	Maximum	Unit
C_{IN}	Input Capacitance	OE_SE, SMODEx[1:0], REF_SEL[1:0]			2		pF
$R_{PULLDOWN}$	Input Pulldown Resistor				50		k Ω
R_{PULLUP}	Input Pullup Resistor	CLK0, CLK1			100		k Ω
		nCLK0, nCLK1			75		k Ω
C_{PD}	Power Dissipation Capacitance	REFOUT	$V_{DDOREF} = 3.465V$		5.0		pF
		REFOUT	$V_{DDOREF} = 2.625V$		4.5		pF
R_{OUT}	Output Impedance	REFOUT	$V_{DDOREF} = 3.3V$		45		Ω
		REFOUT	$V_{DDOREF} = 2.5V$		58		Ω

Function Tables

Table 3. REF_SELx Function Table

Control Input	Selected Input Reference Clock
REF_SEL[1:0]	
00 (default)	CLK0, nCLK0
01	CLK1, nCLK1
10	XTAL
11	XTAL

Table 4. OE_SE Function Table^[a]

OE_SE	REFOUT
0 (default)	High-Impedance
1	Enabled

[a] Synchronous output enable to avoid clock glitch.

Table 5. Input/Output Operation Table, OE_SE

Input Status			Output State
OE_SE	REF_SEL [1:0]	CLKx and nCLKx	REFOUT
0 (default)	Don't care	Don't Care	High Impedance
1	10 or 11	Don't Care	Fanout crystal oscillator
1	00 (default)	CLK0 and nCLK0 are both open circuit	Logic Low
		CLK0 and nCLK0 are tied to ground	Logic Low
		CLK0 is high, nCLK0 is low	Logic High
		CLK0 is low, nCLK0 is high	Logic Low
1	01	CLK1 and nCLK1 are both open circuit	Logic Low
		CLK1 and nCLK1 are tied to ground	Logic Low
		CLK1 is high, nCLK1 is low	Logic High
		CLK1 is low, nCLK1 is high	Logic Low

Table 6. Input/Output Operation Table, SMODEA

Input Status			Output State
SMODEA[1:0]	REF_SEL[1:0]	CLKx and nCLKx	QA[4:0], nQA[4:0]
11	Don't care	Don't Care	High Impedance
00, 01 or 10	10 or 11	Don't Care	Fanout crystal oscillator
00, 01 or 10	00 (default)	CLK0 and nCLK0 are both open circuit	QA[4:0] = Low nQA[4:0] = High
		CLK0 and nCLK0 are tied to ground	QA[4:0] = Low nQA[4:0] = High
		CLK0 is high, nCLK0 is low	QA[4:0] = High nQA[4:0] = Low
		CLK0 is low, nCLK0 is high	QA[4:0] = Low nQA[4:0] = High
00, 01 or 10	01	CLK1 and nCLK1 are both open circuit	QA[4:0] = Low nQA[4:0] = High
		CLK1 and nCLK1 are tied to ground	QA[4:0] = Low nQA[4:0] = High
		CLK1 is high, nCLK1 is low	QA[4:0] = High nQA[4:0] = Low
		CLK1 is low, nCLK1 is high	QA[4:0] = Low nQA[4:0] = High

Table 7. Input/Output Operation Table, SMODEB

Input Status			Output State
SMODEB[1:0]	REF_SEL[1:0]	CLKx and nCLKx	QB[4:0], nQB[4:0]
11	Don't care	Don't Care	High Impedance
00, 01 or 10	10 or 11	Don't Care	Fanout crystal oscillator
00, 01 or 10	00 (default)	CLK0 and nCLK0 are both open circuit	QB[4:0] = Low nQB[4:0] = High
		CLK0 and nCLK0 are tied to ground	QB[4:0] = Low nQB[4:0] = High
		CLK0 is high, nCLK0 is low	QB[4:0] = High nQB[4:0] = Low
		CLK0 is low, nCLK0 is high	QB[4:0] = Low nQB[4:0] = High
00, 01 or 10	01	CLK1 and nCLK1 are both open circuit	QB[4:0] = Low nQB[4:0] = High
		CLK1 and nCLK1 are tied to ground	QB[4:0] = Low nQB[4:0] = High
		CLK1 is high, nCLK1 is low	QB[4:0] = High nQB[4:0] = Low
		CLK1 is low, nCLK1 is high	QB[4:0] = Low nQB[4:0] = High

Table 8. Output Level Selection Table, QA[0:4], nQA[0:4]

SMODEA1	SMODEA0	Output Type
0	0	LVPECL (default)
0	1	LVDS
1	0	HCSL
1	1	High-Impedance

Table 9. Output Level Selection Table, QB[0:4], nQB[0:4]

SMODEB1	SMODEB0	Output Type
0	0	LVPECL (default)
0	1	LVDS
1	0	HCSL
1	1	High-Impedance

Absolute Maximum Ratings

Exposure to absolute maximum rating conditions for extended periods may affect product reliability. Stresses beyond those listed under *Absolute Maximum Ratings* may cause permanent damage to the device. These ratings are stress specifications only. Functional operation of the product at these conditions or any conditions beyond those listed in the *DC Characteristics* or *AC Characteristics* is not implied.

Table 10. Absolute Maximum Ratings

Item	Rating
Supply Voltage, V_{DD}	4.6V
Inputs, V_I XTAL_IN Other Inputs	0V to 2V -0.5V to $V_{DD} + 0.5V$
Outputs, V_O , (HCSL, LVCMOS)	-0.5V to $V_{DDOX}^{[a]} + 0.5V$
Outputs, I_O , (LVPECL) Continuous Current Surge Current	50mA 100mA
Outputs, I_O , (LVDS) Continuous Current Surge Current	10mA 15mA
Junction Temperature	150°C
Storage Temperature, T_{STG}	-65°C to 150°C
ESD - Human Body Mode ^[b]	2000V
ESD - Charged Device Mode ^[b]	500V

[a] V_{DDOX} denotes V_{DDOA} , V_{DDOB} .

[b] According to JEDEC/JSED JS-001-2012/22-C101 E.

Recommended Operating Conditions

Table 11. Recommended Operating Conditions^[a]

Symbol	Parameter	Minimum	Typical	Maximum	Unit
T_A	Ambient air temperature	-40		85	°C
T_J	Junction temperature ^{[b][c]}			125	°C

[a] All conditions in the table must be met to guarantee device functionality.

[b] It is the user's responsibility to ensure that device junction temperature remains below the maximum allowed.

[c] The device is verified to the maximum operating junction temperature through simulation.

DC Electrical Characteristics

Table 12. Power Supply DC Characteristics, $V_{DD} = 3.3V \pm 5$, $V_{DDOA} = V_{DDOB} = 3.3V \pm 5$, $GND = 0V$, $T_A = -40^{\circ}C$ to $85^{\circ}C$ ^[a]

Symbol	Parameter	Test Conditions		Minimum	Typical	Maximum	Unit
V_{DD}	Power Supply Voltage			3.135		3.465	V
V_{DDOA} , V_{DDOB} , V_{DDOREF}	Output Power Voltage			3.135		3.465	V
I_{DD}	Power Supply Current				34	38	mA
I_{EE}	Output Power Supply Current	SMODEA/B[1:0]=00 (default, LVPECL)	Outputs Unloaded	$f_{OUT} = 156.25MHz$	88	100	mA
				$f_{OUT} = 781.25MHz$	147	166	mA
				$f_{OUT} = 1500MHz$	181	205	mA

[a] V_{DDOX} denotes V_{DDOA} , V_{DDOB}

Table 13. Power Supply DC Characteristics, $V_{DD} = 3.3V \pm 5$ or $2.5V \pm 5$, $V_{DDOA} = V_{DDOB} = 2.5V \pm 5$, $GND = 0V$, $T_A = -40^{\circ}C$ to $85^{\circ}C$ ^[a]

Symbol	Parameter	Test Conditions		Minimum	Typical	Maximum	Unit
V_{DD}	Power Supply Voltage			2.375		3.465	V
V_{DDOA} , V_{DDOB} , V_{DDOREF}	Output Power Voltage			2.375		3.465	V
I_{DD}	Power Supply Current				34	38	mA
I_{EE}	Output Power Supply Current	SMODEA/B[1:0]=00 (default, LVPECL)	Outputs Unloaded	$f_{OUT} = 156.25MHz$	83	94	mA
				$f_{OUT} = 781.25MHz$	140	158	mA
				$f_{OUT} = 1500MHz$	181	205	mA

[a] V_{DDOX} denotes V_{DDOA} , V_{DDOB}

Table 14. Maximum Output Supply Current, $V_{DDOx} = 3.3V \pm 5\%$, or $2.5V \pm 5\%$, $GND = 0V$, $T_A = -40^\circ C$ to $85^\circ C$ ^[a]

Symbol	Parameter	Test Conditions		$V_{DDOx} = 3.3 \pm 5\%$			$V_{DDOx} = 2.5 \pm 5\%$			Unit
				Min.	Typ.	Max.	Min.	Typ.	Max.	
$I_{DDOA} + I_{DDOB}$	Bank A & Bank B Current SMODEA/B[1:0]=00 (default; LVPECL)	Outputs Unloaded	$f_{OUT} = 156.25MHz$		44	51		43	50	mA
			$f_{OUT} = 781.25MHz$		99	114		99	114	mA
			$f_{OUT} = 1500MHz$		147	169		147	169	mA
		Outputs Loaded 50Ω to $V_{DDOx} - 2V$	$f_{OUT} = 156.25MHz$		243	279		217	249	mA
			$f_{OUT} = 781.25MHz$		306	352		262	301	mA
			$f_{OUT} = 1500MHz$		355	408		302	347	mA
$I_{DDOA} + I_{DDOB}$	Bank A & Bank B Current SMODEA/B[1:0]=01 (LVDS)	Outputs Unloaded	$f_{OUT} = 156.25MHz$		94	108		93	107	mA
			$f_{OUT} = 468.75MHz$		135	155		134	154	mA
			$f_{OUT} = 800MHz$		166	191		166	191	mA
		Outputs Loaded	$f_{OUT} = 156.25MHz$		91	105		91	105	mA
			$f_{OUT} = 468.75MHz$		127	146		128	147	mA
			$f_{OUT} = 800MHz$		165	189		165	190	mA
$I_{DDOA} + I_{DDOB}$	Bank A & Bank B Current SMODEA/B[1:0]=10 (HCSL)	Outputs Unloaded	$f_{OUT} = 100MHz$		42	48		41	47	mA
			$f_{OUT} = 156.25MHz$		48	55		46	53	mA
			$f_{OUT} = 250MHz$		57	66		55	64	mA
			$f_{OUT} = 750MHz$		105	118		103	117	mA
		Outputs Loaded	$f_{OUT} = 100MHz$		190	218		188	216	mA
			$f_{OUT} = 156.25MHz$		195	224		193	222	mA
			$f_{OUT} = 250MHz$		204	234		202	233	mA
			$f_{OUT} = 750MHz$		258	292		257	290	mA

[a] V_{DDOx} denotes V_{DDOA} , V_{DDOB}

Table 15. LVCMOS/LVTTL DC Characteristics, $V_{DD} = 3.3V \pm 5\%$, $2.5V \pm 5\%$, $V_{DDOREF} = 3.3V \pm 5\%$ or $2.5V \pm 5\%$, $GND = 0V$, $T_A = -40^\circ C$ to $85^\circ C$

Symbol	Parameter	Test Conditions	Minimum	Typical	Maximum	Unit
V_{IH}	Input High Voltage	$V_{DD} = 3.3V \pm 5\%$	2		$V_{DD} + 0.3$	V
		$V_{DD} = 2.5V \pm 5\%$	1.7		$V_{DD} + 0.3$	V
V_{IL}	Input Low Voltage	$V_{DD} = 3.3V \pm 5\%$	-0.3		0.8	V
		$V_{DD} = 2.5V \pm 5\%$	-0.3		0.7	V
I_{IH}	Input High Current	$V_{DD} = V_{IN} = 3.465V$ or $2.625V$			150	μA
I_{IL}	Input Low Current	$V_{DD} = 3.465V$ or $2.625V$, $V_{IN} = 0V$	-5			μA
V_{OH}	Output High Voltage	$V_{DDOREF} = 3.3V \pm 5\%$: $I_{OH} = -1mA$	2.6			V
		$V_{DDOREF} = 2.5V \pm 5\%$: $I_{OH} = -1mA$	1.8			V
V_{OL}	Output Low Voltage	$V_{DDOREF} = 3.3V \pm 5\%$ or $2.5V \pm 5\%$: $I_{OL} = 1mA$			0.5	V

Table 16. Differential DC Characteristics, $V_{DD} = 3.3V \pm 5\%$ or $2.5V \pm 5\%$, $GND = 0V$, $T_A = -40^\circ C$ to $85^\circ C$

Symbol	Parameter	Test Conditions	Minimum	Typical	Maximum	Unit
I_{IH}	Input High Current	CLK[0:1], nCLK[0:1] $V_{DD} = V_{IN} = 3.465V$ or $2.625V$			150	μA
I_{IL}	Input Low Current	CLK[0:1], nCLK[0:1] $V_{DD} = 3.465V$ or $2.625V$, $V_{IN} = 0V$	-150			μA
V_{PP}	Peak-to-Peak Input Voltage ^[a]		0.240		1.3	V
V_{CMR}	Common Mode Input Voltage ^{[a][b]}		$GND + 0.5$		$V_{DD} - 0.85$	V

[a] Input voltage should not be less than -0.3V, and greater than V_{DD} .

[b] Common mode voltage is defined as the crosspoint.

Table 17. LVPECL DC Characteristics, $V_{DD} = V_{DDOA} = V_{DDOB} = 3.3V \pm 5\%$, $GND = 0V$, $T_A = -40^\circ C$ to $85^\circ C$ ^[a]

Symbol	Parameter	Test Conditions	Minimum	Typical	Maximum	Unit
V_{OH}	Output High Voltage ^[b]		$V_{DDOX} - 1.135$		$V_{DDOX} - 0.8$	V
V_{OL}	Output Low Voltage ^[b]		$V_{DDOX} - 2.1$		$V_{DDOX} - 1.6$	V
V_{SWING}	Peak-to-Peak Output Voltage Swing	$DC \leq f_{OUT} \leq 500MHz$	0.6		1.24	V
		$500MHz < f_{OUT} \leq 1GHz$	0.4		1.10	V
		$f_{OUT} > 1.0GHz$		0.60		V

[a] V_{DDOX} denotes V_{DDOA} and V_{DDOB} .

[b] Outputs terminated with 50Ω to $V_{DDOX} - 2V$.

Table 18. LVPECL DC Characteristics, $V_{DD} = V_{DDOA} = V_{DDOB} = 3.3V \pm 5\%$, $GND = 0V$, $T_A = -40^\circ C$ to $85^\circ C$ ^[a]

Symbol	Parameter	Test Conditions	Minimum	Typical	Maximum	Unit
V_{OH}	Output High Voltage ^[b]		$V_{DDOX} - 1.125$		$V_{DDOX} - 0.8$	V
V_{OL}	Output Low Voltage ^[b]		$V_{DDOX} - 2.1$		$V_{DDOX} - 1.6$	V
V_{SWING}	Peak-to-Peak Output Voltage Swing	$DC \leq f_{OUT} \leq 500MHz$	0.6		1.20	V
		$500MHz < f_{OUT} \leq 1GHz$	0.4		1.00	V
		$f_{OUT} > 1.0GHz$		0.56		V

[a] V_{DDOX} denotes V_{DDOA} and V_{DDOB} .

[b] Outputs terminated with 50Ω to $V_{DDOX} - 2V$.

Table 19. LVDS DC Characteristics, $V_{DDOA} = V_{DDOB} = 3.3V \pm 5\%$, $GND = 0V$, $T_A = -40^\circ C$ to $85^\circ C$

Symbol	Parameter	Test Conditions	Minimum	Typical	Maximum	Unit
V_{OD}	Differential Output Voltage		435		570	mV
ΔV_{OD}	V_{OD} Magnitude Change			50		mV
V_{OS}	Offset Voltage		1.16		1.375	V
ΔV_{OS}	V_{OS} Magnitude Change			50		mV

Table 20. LVDS DC Characteristics, $V_{DDOA} = V_{DDOB} = 2.5V \pm 5\%$, $GND = 0V$, $T_A = -40^\circ C$ to $85^\circ C$

Symbol	Parameter	Test Conditions	Minimum	Typical	Maximum	Unit
V_{OD}	Differential Output Voltage		425		570	mV
ΔV_{OD}	V_{OD} Magnitude Change			50		mV
V_{OS}	Offset Voltage		1.15		1.365	V
ΔV_{OS}	V_{OS} Magnitude Change			50		mV

Table 21. Crystal Characteristics^[a]

Parameter	Test Conditions	Minimum	Typical	Maximum	Unit
Mode of Oscillation		Fundamental			
Frequency		10		40	MHz
Equivalent Series Resistance (ESR)				50	Ω
Shunt Capacitance				7	pF
Capacitive Loading (C_L)			12	18	pF

[a] Crystal operation requires tuning caps. For more information, see [Applications Information](#).

AC Electrical Characteristics

Table 22. AC Characteristics, $V_{DD} = V_{DDOA} = V_{DDOB} = V_{DDOREF} = 3.3V \pm 5\%$, $GND = 0V$, $T_A = -40^\circ C$ to $85^\circ C$ ^{[a][b]}

Symbol	Parameter		Test Conditions	Minimum	Typical	Maximum	Unit	
f_{OUT}	Output Frequency	LVPECL Outputs		DC		1500	MHz	
		LVDS Outputs		DC		800	MHz	
		HCSL Outputs		DC		750	MHz	
		LVC MOS (REFOUT)		DC		250	MHz	
t_{jit}	Buffer Additive Phase Jitter, RMS: Integration Range 12kHz - 20MHz REF_SEL[1:0] = 00 or 01		Clock Frequency = 156.25MHz; Input Clock from 8T49NS010A, Input Clock Jitter = 83.9fs; SMODEA/B[1:0] = 00 (default, LVPECL)		37.6		fs	
$t_{jit}(\emptyset)$	RMS Phase Jitter; 25MHz Integration Range: 100Hz - 1MHz		REF_SEL[1:0] = 10 or 11 ^[c]		0.307		ps	
NF	Noise Floor	LVPECL Outputs	Offset Frequency > 10MHz; 156.25MHz Clock Frequency		-159.5		dBc/Hz	
		LVDS Outputs			-157.9		dBc/Hz	
		HCSL Outputs			-157.7		dBc/Hz	
t_{PD}	Propagation Delay ^[d]	CLK0, nCLK0 or CLK1, nCLK1 to any Qx, nQx Outputs	SMODEA/B[1:0] = 00 (default, LVPECL)	$f_{OUT} \leq 1GHz$	0.75	1.50	ns	
				$f_{OUT} > 1GHz$		1.23	ns	
			SMODEA/B[1:0] = 01 (LVDS)		0.820		1.475	ns
			SMODEA/B[1:0] = 10 (HCSL)		0.860		1.440	ns
$t_{sk(o)}$	Output Skew ^{[e][f]}					81	ps	
$t_{sk(pp)}$	Part-to-Part Skew ^{[f][g]}				200		ps	
V_{OH}	Voltage High ^{[h][i]}	HCSL Outputs	$R_T = 50\Omega$ to GND, $C_L \leq 5pF$	520		931	mV	
V_{OL}	Voltage Low ^{[h][j]}	HCSL Outputs		-150		150	mV	
V_{CROSS}	Absolute Crossing Voltage ^{[h][k][l]}	HCSL Outputs		225		460	mV	
ΔV_{CROSS}	Total Variation of V_{CROSS} over all Edges ^{[h][k][m]}	HCSL Outputs				140	mV	
	Rise/Fall Edge Rate ^{[c][n][o]}	HCSL Outputs		0.6		4.0	V/ns	
t_R / t_F	Output Rise/Fall Time	LVPECL Outputs	20% to 80%		200	695	ps	
		LVDS Outputs	20% to 80%		230	510	ps	
		HCSL Outputs	20% to 80%		260	420	ps	
		REFOUT	20% to 80%		438	575	ps	
odc	Output Duty Cycle ^[p]		With Crystal Input	45		55	%	
			With External 50%/ 50% Duty Cycle Clock Input	45		55	%	
MUX_ISOLATION	MUX Isolation		156.25MHz		75		dB	

[a] Electrical parameters are guaranteed over the specified ambient operating temperature range, which is established when the device is mounted in a test socket with maintained transverse airflow greater than 500 lfm. The device will meet specifications after thermal equilibrium has been reached under these conditions.

- [b] LVPECL parameters characterized up to 1.5GHz. LVDS parameters characterized up to 800MHz. HCSL parameters characterized up to 750MHz.
- [c] Measurement taken from differential waveform.
- [d] Measured from the differential input crosspoint to the differential output crosspoint.
- [e] Defined as skew between outputs at the same supply voltage and with equal load conditions. Measured at the differential crosspoint.
- [f] This parameter is defined in accordance with JEDEC Standard 65.
- [g] Defined as skew between outputs on different devices operating at the same supply voltage, same temperature, same frequency and with equal load conditions. Using the same type of inputs on each device, the outputs are measured at the differential crosspoint
- [h] Measurement taken from single-ended waveform.
- [i] Vlow is defined as the statistical average Low value as obtained by using the oscilloscope Vlow Math function.
- [j] Vhigh is defined as the statistical average High value as obtained by using the oscilloscope Vhigh Math function.
- [k] Measured at crosspoint where the instantaneous voltage value of the rising edge of Qx equals the falling edge of nQx.
- [l] Refers to the total variation from the lowest crosspoint to the highest, regardless of which edge is crossing. Refers to all crosspoint for this measurement.
- [m] Defined as the total variation of all crossing voltages of rising Qx and falling nQx, This is the maximum allowed variance in Vcross for any particular system.
- [n] Measured from -150mV to +150mV on the differential waveform (Qx minus nQx). The signal must be monotonic through the measurement region for rise and fall time. The 300mV measurement window is centered on the differential zero crossing.
- [o] Measured at 100MHz.
- [p] Measured for the following frequencies: 25MHz, 100MHz, 125MHz, 156.25MHz, 312.5MHz, 400MHz, 644.5313MHz, and 750MHz.

Table 23. AC Characteristics, $V_{DD} = 3.3V \pm 5\%$, $V_{DDOA} = V_{DDOB} = V_{DDOREF} = 2.5V \pm 5\%$, $GND = 0V$, $T_A = -40^\circ C$ to $85^\circ C$ ^{[a][b]}

Symbol	Parameter		Test Conditions	Minimum	Typical	Maximum	Unit
f_{OUT}	Output Frequency	LVPECL Outputs		DC		1500	MHz
		LVDS Outputs		DC		800	MHz
		HCSL Outputs		DC		750	MHz
		LVC MOS (REFOUT)		DC		250	MHz
t_{jit}	Buffer Additive Phase Jitter, RMS: Integration Range 12kHz - 20MHz REF_SEL[1:0] = 00 or 01		Clock Frequency = 156.25MHz; Input Clock from 8T49NS010A, Input Clock Jitter = 83.9fs; SMODEA/B[1:0] = 00 (default, LVPECL)		45.5		fs
$t_{jit}(\emptyset)$	RMS Phase Jitter; 25MHz Integration Range: 100Hz - 1MHz		REF_SEL[1:0] = 10 or 11 ^[c]		0.309		ps
NF	Noise Floor	LVPECL	Offset Frequency > 10MHz; 156.25MHz Clock Frequency		-158.5		dBc/Hz
		LVDS			-158.1		dBc/Hz
		HCSL			-157.6		dBc/Hz
t_{PD}	Propagation Delay ^[d]	CLK0, nCLK0 or CLK1, nCLK1 to any Qx, nQx Outputs	SMODEA/B[1:0] = 00 (default, LVPECL)	$f_{OUT} \leq 1GHz$	0.58	1.66	ns
				$f_{OUT} > 1GHz$		1.23	ns
			SMODEA/B[1:0] = 01 (LVDS)	0.75	1.50	ns	
		SMODEA/B[1:0] = 10 (HCSL)	0.87	1.43	ns		
$t_{sk(o)}$	Output Skew ^{[e][f]}					75	ps
$t_{sk(pp)}$	Part-to-Part Skew ^{[f][g]}				200		ps
V_{OH}	Voltage High ^{[h][i]}	HCSL Outputs	$R_T = 50\Omega$ to GND, $C_L \leq 5pF$	520		931	mV
V_{OL}	Voltage Low ^{[h][j]}	HCSL Outputs		-150		150	mV
V_{CROSS}	Absolute Crossing Voltage ^{[h][k][l]}	HCSL Outputs		225		460	mV
ΔV_{CROSS}	Total Variation of V_{CROSS} over all Edges ^{[h][k][m]}	HCSL Outputs				140	mV
	Rise/Fall Edge Rate ^{[c][n][o]}	HCSL Outputs		0.6		4	V/ns
t_R / t_F	Output Rise/Fall Time	LVPECL Outputs	20% to 80%		130	450	ps
		LVDS Outputs	20% to 80%		225	475	ps
		HCSL Outputs	20% to 80%		275	485	ps
		REFOUT	20% to 80%		434	600	ps
odc	Output Duty Cycle ^[p]		With Crystal Input	45		55	%
			With external 50%/ 50% Duty Cycle Clock Input	45		55	%
MUX_ISOLATION	MUX Isolation		156.25MHz		75		dB

[a] Electrical parameters are guaranteed over the specified ambient operating temperature range, which is established when the device is mounted in a test socket with maintained transverse airflow greater than 500 lfm. The device will meet specifications after thermal equilibrium has been reached under these conditions.

- [b] LVPECL parameters characterized up to 1.5GHz. LVDS parameters characterized up to 800MHz. HCSL parameters characterized up to 750MHz.
- [c] Measurement taken from differential waveform.
- [d] Measured from the differential input crosspoint to the differential output crosspoint.
- [e] Defined as skew between outputs at the same supply voltage and with equal load conditions. Measured at the differential crosspoint.
- [f] This parameter is defined in accordance with JEDEC Standard 65.
- [g] Defined as skew between outputs on different devices operating at the same supply voltage, same temperature, same frequency and with equal load conditions. Using the same type of inputs on each device, the outputs are measured at the differential crosspoint
- [h] Measurement taken from single-ended waveform.
- [i] Vlow is defined as the statistical average Low value as obtained by using the oscilloscope Vlow Math function.
- [j] Vhigh is defined as the statistical average High value as obtained by using the oscilloscope Vhigh Math function.
- [k] Measured at crosspoint where the instantaneous voltage value of the rising edge of Qx equals the falling edge of nQx.
- [l] Refers to the total variation from the lowest crosspoint to the highest, regardless of which edge is crossing. Refers to all crosspoint for this measurement.
- [m] Defined as the total variation of all crossing voltages of rising Qx and falling nQx, This is the maximum allowed variance in Vcross for any particular system.
- [n] Measured from -150mV to +150mV on the differential waveform (Qx minus nQx). The signal must be monotonic through the measurement region for rise and fall time. The 300mV measurement window is centered on the differential zero crossing.
- [o] Measured at 100MHz.
- [p] Measured for the following frequencies: 25MHz, 100MHz, 125MHz, 156.25MHz, 312.5MHz, 400MHz, 644.5313MHz, and 750MHz.

Table 24. AC Characteristics, $V_{DD} = V_{DDOA} = V_{DDOB} = V_{DDOREF} = 2.5V \pm 5\%$, $GND = 0V$, $T_A = -40^\circ C$ to $85^\circ C$ ^{[a][b]}

Symbol	Parameter		Test Conditions	Minimum	Typical	Maximum	Unit
f_{OUT}	Output Frequency	LVPECL Outputs		DC		1500	MHz
		LVDS Outputs		DC		800	MHz
		HCSL Outputs		DC		750	MHz
		LVC MOS (REFOUT)		DC		250	MHz
t_{jit}	Buffer Additive Phase Jitter, RMS: Integration Range 12kHz - 20MHz REF_SEL[1:0] = 00 or 01		Clock Frequency = 156.25MHz; Input Clock from 8T49NS010A, Input Clock Jitter = 83.9fs; SMODEA/B[1:0] = 00 (default, LVPECL)		46.9		fs
$t_{jit}(\emptyset)$	RMS Phase Jitter; 25MHz Integration Range: 100Hz - 1MHz		REF_SEL[1:0] = 10 or 11 ^[c]		0.313		ps
NF	Noise Floor	LVPECL	Offset Frequency > 10MHz; 156.25MHz Clock Frequency		-159.3		dBc/Hz
		LVDS			-157.9		dBc/Hz
		HCSL			-157.8		dBc/Hz
t_{PD}	Propagation Delay ^[d]	CLK0, nCLK0 or CLK1, nCLK1 to any Qx, nQx Outputs	SMODEA/B[1:0] = 00 (default, LVPECL)	$f_{OUT} \leq 1GHz$	0.63	1.6	ns
				$f_{OUT} > 1GHz$		1.23	ns
			SMODEA/B[1:0] = 01 (LVDS)		0.825	1.6	ns
			SMODEA/B[1:0] = 10 (HCSL)		0.865	1.5	ns
$t_{sk(o)}$	Output Skew ^{[e][f]}					75	ps
$t_{sk(pp)}$	Part-to-Part Skew ^{[f][g]}				200		ps
V_{OH}	Voltage High ^{[h][i]}	HCSL Outputs	$R_T = 50\Omega$ to GND, $C_L \leq 5pF$		520	920	mV
V_{OL}	Voltage Low ^{[h][j]}	HCSL Outputs			-150	150	mV
V_{CROSS}	Absolute Crossing Voltage ^{[k][l]}	HCSL Outputs			225	460	mV
ΔV_{CROSS}	Total Variation of V_{CROSS} over all Edges ^{[h][k][m]}	HCSL Outputs				140	mV
	Rise/Fall Edge Rate ^{[c][n][o]}	HCSL Outputs			0.6	4	V/ns
t_R / t_F	Output Rise/Fall Time	LVPECL Outputs	20% to 80%		200	525	ps
		LVDS Outputs	20% to 80%		220	485	ps
		HCSL Outputs	20% to 80%		265	485	ps
		REFOUT	20% to 80%		432	625	ps
odc	Output Duty Cycle ^[p]	With Crystal Input		45		55	%
		With external 50%/ 50% Duty Cycle Clock Input		45		55	%
MUX_ISOLATION	MUX Isolation	156.25MHz			75		dB

[a] Electrical parameters are guaranteed over the specified ambient operating temperature range, which is established when the device is mounted in a test socket with maintained transverse airflow greater than 500 lpm. The device will meet specifications after thermal equilibrium has been reached under these conditions.

- [b] LVPECL parameters characterized up to 1.5GHz. LVDS parameters characterized up to 800MHz. HCSL parameters characterized up to 750MHz.
- [c] Measurement taken from differential waveform.
- [d] Measured from the differential input crosspoint to the differential output crosspoint.
- [e] Defined as skew between outputs at the same supply voltage and with equal load conditions. Measured at the differential crosspoint.
- [f] This parameter is defined in accordance with JEDEC Standard 65.
- [g] Defined as skew between outputs on different devices operating at the same supply voltage, same temperature, same frequency and with equal load conditions. Using the same type of inputs on each device, the outputs are measured at the differential crosspoint
- [h] Measurement taken from single-ended waveform.
- [i] Vlow is defined as the statistical average Low value as obtained by using the oscilloscope Vlow Math function.
- [j] Defined as the minimum instantaneous voltage including undershoot.
- [k] Measured at crosspoint where the instantaneous voltage value of the rising edge of Qx equals the falling edge of nQx.
- [l] Refers to the total variation from the lowest crosspoint to the highest, regardless of which edge is crossing. Refers to all crosspoint for this measurement.
- [m] Defined as the total variation of all crossing voltages of rising Qx and falling nQx, This is the maximum allowed variance in Vcross for any particular system.
- [n] Measured from -150mV to +150mV on the differential waveform (Qx minus nQx). The signal must be monotonic through the measurement region for rise and fall time. The 300mV measurement window is centered on the differential zero crossing.
- [o] Measured at 100MHz.
- [p] Measured for the following frequencies: 25MHz, 100MHz, 125MHz, 156.25MHz, 312.5MHz, 400MHz, 644.5313MHz, and 750MHz.

Additive Phase Jitter

The spectral purity in a band at a specific offset from the fundamental compared to the power of the fundamental is called the **dBc Phase Noise**. This value is normally expressed using a Phase noise plot and is most often the specified plot in many applications. Phase noise is defined as the ratio of the noise power present in a 1Hz band at a specified offset from the fundamental frequency to the power value of the fundamental. This ratio is expressed in decibels (dBm) or a ratio of the power in the 1Hz band to the power in the fundamental. When the required offset is specified, the phase noise is called a **dBc** value, which simply means dBm at a specified offset from the fundamental. By investigating jitter in the frequency domain, we get a better understanding of its effects on the desired application over the entire time record of the signal. It is mathematically possible to calculate an expected bit error rate given a phase noise plot.

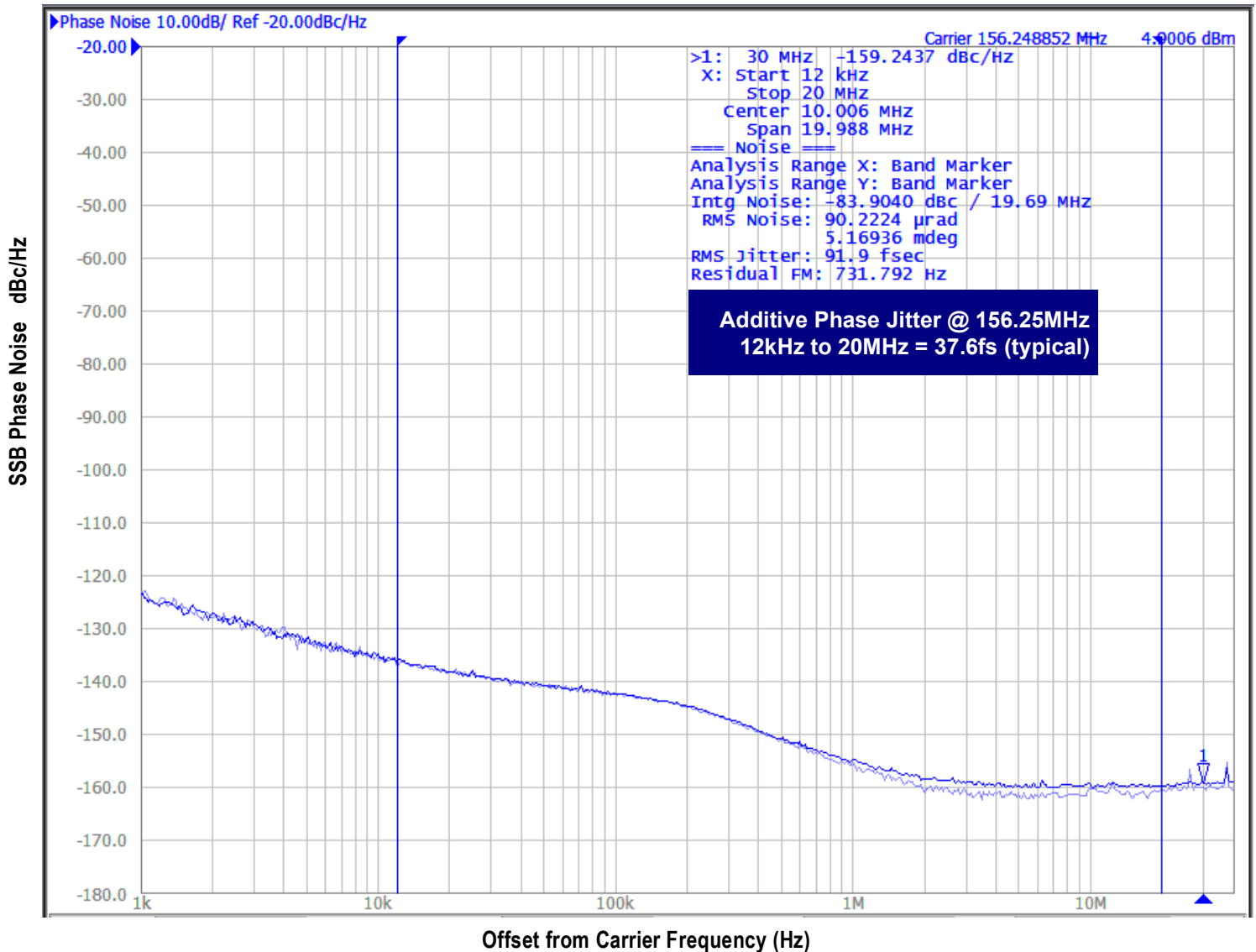

As with most timing specifications, phase noise measurements have issues relating to the limitations of the measurement equipment. The noise floor of the equipment can be higher or lower than the noise floor of the device. Additive phase noise is dependent on both the noise floor of the input source and measurement equipment.

The additive phase jitter for this device was measured using an Renesas Clock Driver 8T49NS010A as an input source and Agilent E5052 phase noise analyzer.

Applications Information

Recommendations for Unused Input and Output Pins

Inputs

CLK/nCLK Inputs

For applications not requiring the use of the differential input, both CLK and nCLK can be left floating. Though not required, but for additional protection, 1k Ω resistors can be tied from CLK to ground and nCLK to V_{DD}.

Crystal Inputs

For applications not requiring the use of the crystal oscillator input, both XTAL_IN and XTAL_OUT can be left floating. Though not required, but for additional protection, a 1k Ω resistor can be tied from XTAL_IN to ground.

LVC MOS Control Pins

All control pins have internal pull-downs; additional resistance is not required but can be added for additional protection. A 1k Ω resistor can be used.

Outputs

LVC MOS Output (REFOUT)

If LVC MOS output is not used, then disable the output and it can be left floating.

LVPECL and HCSL Outputs

Any unused output pairs can be left floating. We recommend that there is no trace attached.

LVDS Outputs

Any unused LVDS output pairs can be either left floating or terminated with 100 Ω across. If they are left floating, we recommend that there is no trace attached.

Differential Outputs

If all the outputs of any bank are not used, then disable all outputs to High-Impedance.

Crystal Input Interface

The 8T39210 has been characterized with 18pF parallel resonant crystals. The capacitor values, C1 and C2, shown in *Figure 1* below were determined using an 18pF parallel resonant crystal and were chosen to minimize the ppm error. In addition, the recommended 12pF parallel resonant crystal tuning is shown in *Figure 2*. The optimum C1 and C2 values can be slightly adjusted for different board layouts.

Figure 1. Crystal Input Interface

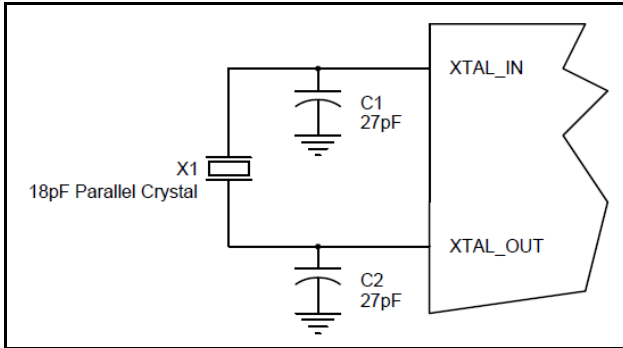
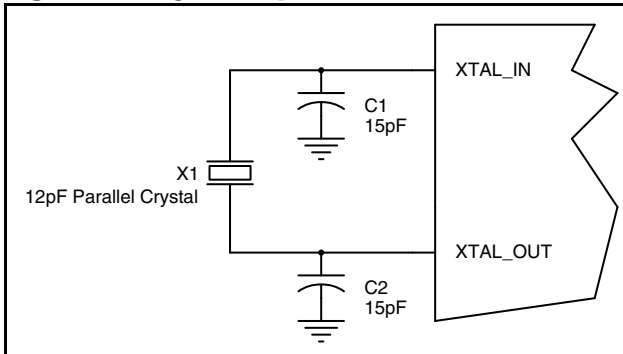

Figure 2. Crystal Input Interface



Power-up Ramp Sequence

This device has multiple supply pins dedicated for different blocks. Output power supplies V_{DDOx} (V_{DDOA} , V_{DDOB} , V_{DDOREF}) must ramp up before, or concurrently with core power supply V_{DD} . All power supplies must ramp up in a linear fashion and monotonically.

Overdriving the XTAL Interface

The XTAL_IN input can be overdriven by an LVCMOS driver or by one side of a differential driver through an AC coupling capacitor. The XTAL_OUT pin can be left floating. The amplitude of the input signal should be between 500mV and 1.8V and the slew rate should not be less than 0.2V/ns. For 3.3V LVCMOS inputs, the amplitude must be reduced from full swing to at least half the swing in order to prevent signal interference with the power rail and to reduce internal noise. Figure 3 shows an example of the interface diagram for a high speed 3.3V LVCMOS driver.

This configuration requires that the sum of the output impedance of the driver (R_o) and the series resistance (R_s) equals the transmission line impedance. In addition, matched termination at the crystal input will attenuate the signal in half. This can be done in one of two ways. First, R1 and R2 in parallel should equal the transmission line impedance. For most 50Ω applications, R1 and R2 can be 100Ω. This can also be accomplished by removing R1 and changing R2 to 50Ω. The values of the resistors can be increased to reduce the loading for a slower and weaker LVCMOS driver. Figure 4 shows an example of the interface diagram for an LVPECL driver. This is a standard LVPECL termination with one side of the driver feeding the XTAL_IN input. It is recommended that all components in the schematics be placed in the layout. Though some components might not be used, they can be utilized for debugging purposes. The datasheet specifications are characterized and guaranteed by using a quartz crystal as the input.

Figure 3. General Diagram for LVCMOS Driver to XTAL Input Interface

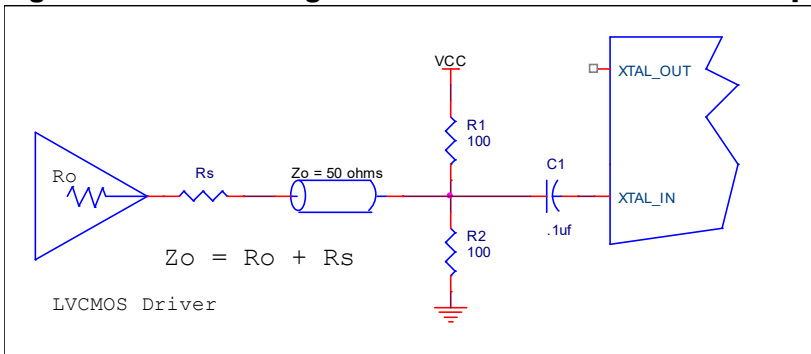
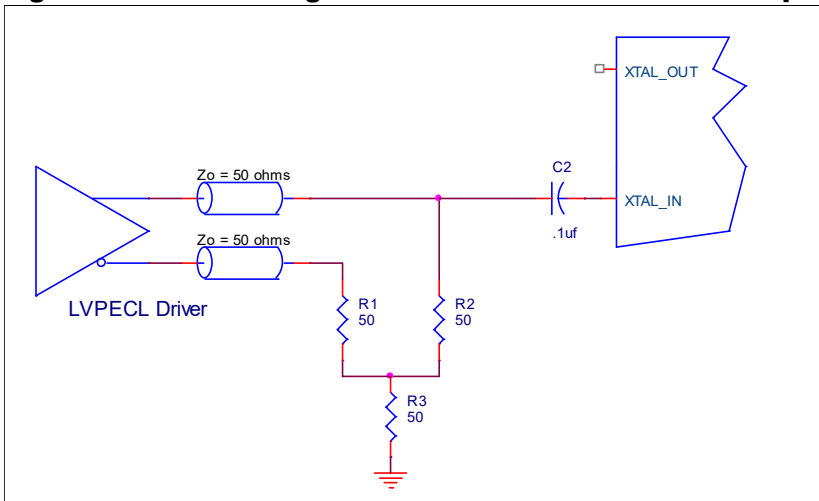

Figure 4. General Diagram for LVPECL Driver to XTAL Input Interface



Wiring the Differential Input to Accept Single-Ended Levels

Figure 5 shows how a differential input can be wired to accept single ended levels. The reference voltage $V_1 = V_{DD}/2$ is generated by the bias resistors R1 and R2. The bypass capacitor (C1) is used to help filter noise on the DC bias. This bias circuit should be located as close to the input pin as possible. The ratio of R1 and R2 might need to be adjusted to position the V_1 in the center of the input voltage swing. For example, if the input clock swing is 2.5V and $V_{DD} = 3.3V$, R1 and R2 value should be adjusted to set V_1 at 1.25V. The values below are for when both the single ended swing and V_{DD} are at the same voltage. This configuration requires that the sum of the output impedance of the driver (R_o) and the series resistance (R_s) equals the transmission line impedance. In addition, matched termination at the input will attenuate the signal in half. This can be done in one of two ways. First, R3 and R4 in parallel should equal the transmission line impedance. For most 50Ω applications, R3 and R4 can be 100Ω. The values of the resistors can be increased to reduce the loading for slower and weaker LVCMOS driver.

When using single-ended signaling, the noise rejection benefits of differential signaling are reduced. Even though the differential input can handle full rail LVCMOS signaling, it is recommended that the amplitude be reduced. The datasheet specifies a lower differential amplitude, however this only applies to differential signals. For single-ended applications, the swing can be larger, however V_{IL} cannot be less than -0.3V and V_{IH} cannot be more than $V_{DD} + 0.3V$. Suggest edge rate faster than 1V/ns. Though some of the recommended components might not be used, the pads should be placed in the layout. They can be utilized for debugging purposes. The datasheet specifications are characterized and guaranteed by using a differential signal.

Figure 5. Recommended Schematic for Wiring a Differential Input to Accept Single-ended Levels

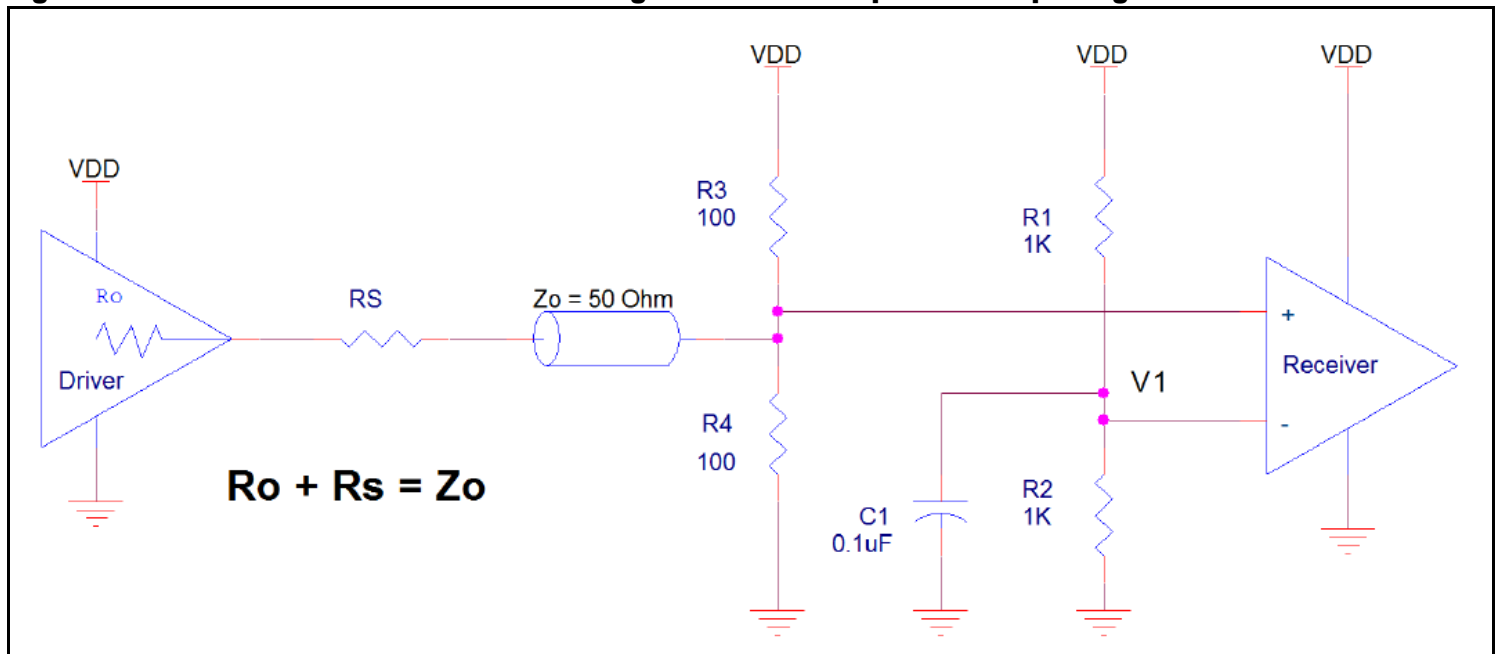

3.3V Differential Clock Input Interface

The CLK/nCLK accepts LVDS, LVPECL, HCSL and other differential signals. Both differential signals must meet the V_{PP} and V_{CMR} input requirements. Figure 6 to Figure 9 show interface examples for the CLK/nCLK input driven by the most common driver types. The input interfaces suggested here are examples only. Please consult with the vendor of the driver component to confirm the driver termination requirements.

Figure 6. CLK/nCLK Input Driven by a 3.3V LVPECL Driver

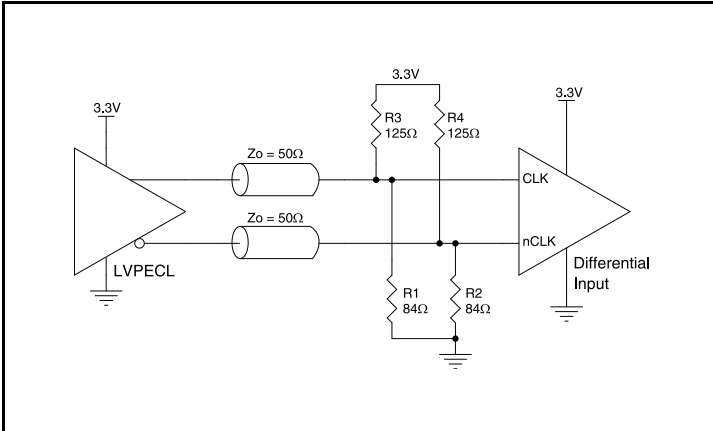

Figure 7. CLK/nCLK Input Driven by a 3.3V HCSL Driver

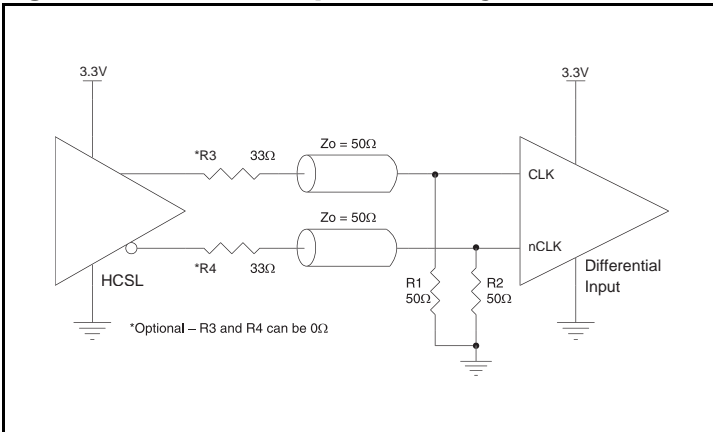

Figure 8. CLK/nCLK Input Driven by a 3.3V LVPECL Driver

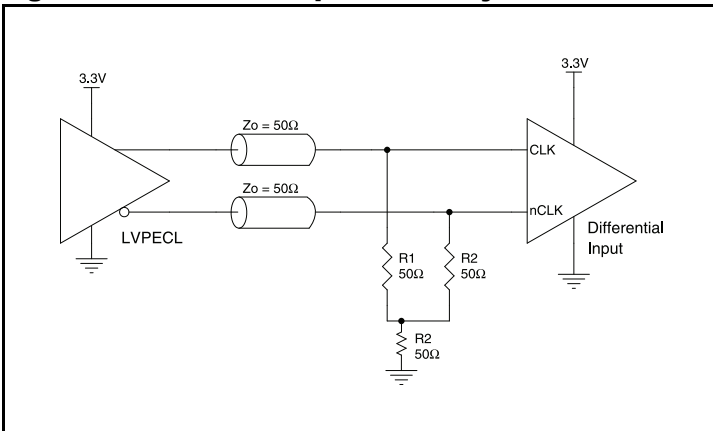
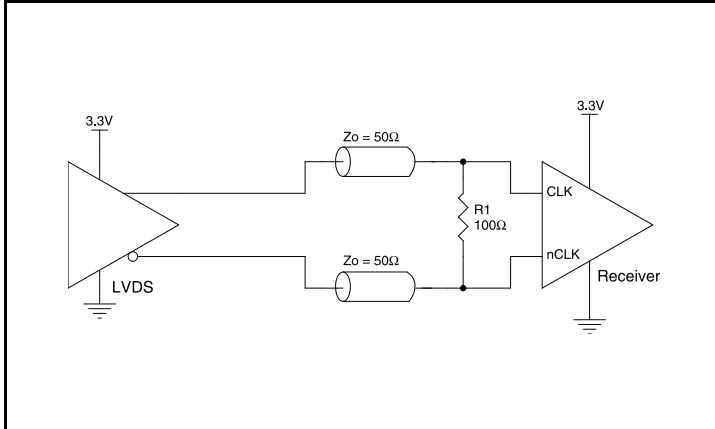

Figure 9. CLK/nCLK Input Driven by a 3.3V LVDS Driver



2.5V Differential Clock Input Interface

The CLK /nCLK accepts LVDS, LVPECL, HCSL and other differential signals. Both differential signals must meet the V_{PP} and V_{CMR} input requirements. Figure 10 to Figure 13 show interface examples for the CLK/nCLK input driven by the most common driver types. The input interfaces suggested here are examples only. Please consult with the vendor of the driver component to confirm the driver termination requirements.

Figure 10. CLK/nCLK Input Driven by a 2.5V LVPECL Driver

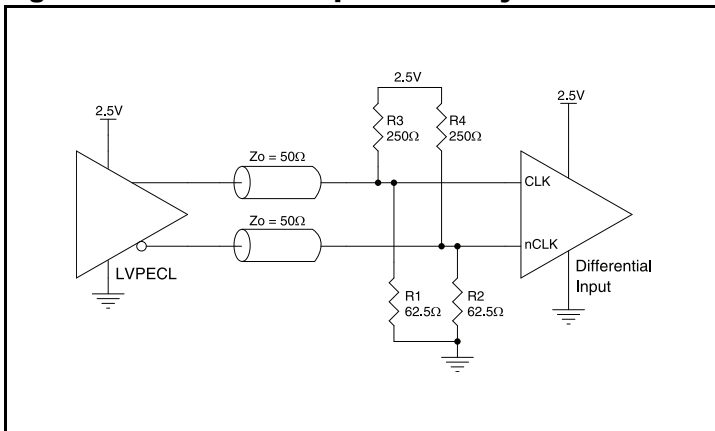

Figure 11. CLK/nCLK Input Driven by a 2.5V LVDS Driver

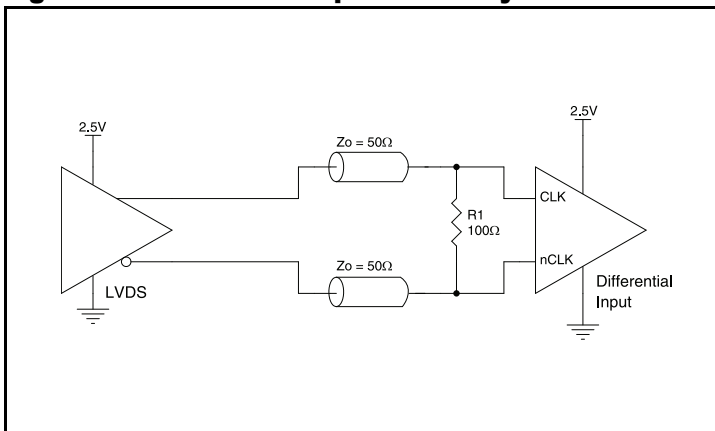

Figure 12. CLK/nCLK Input Driven by a 2.5V LVPECL Driver

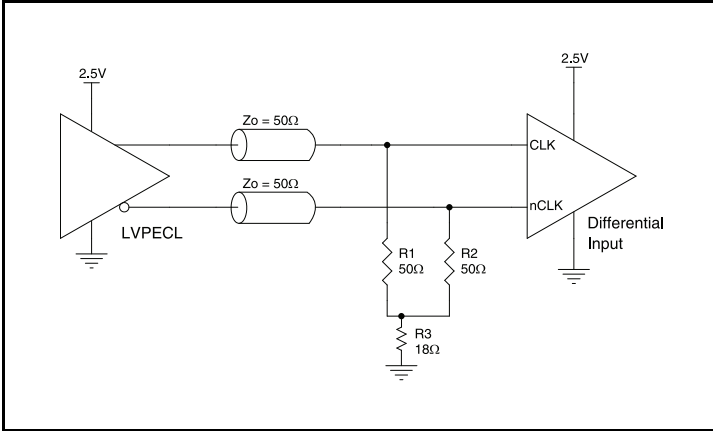
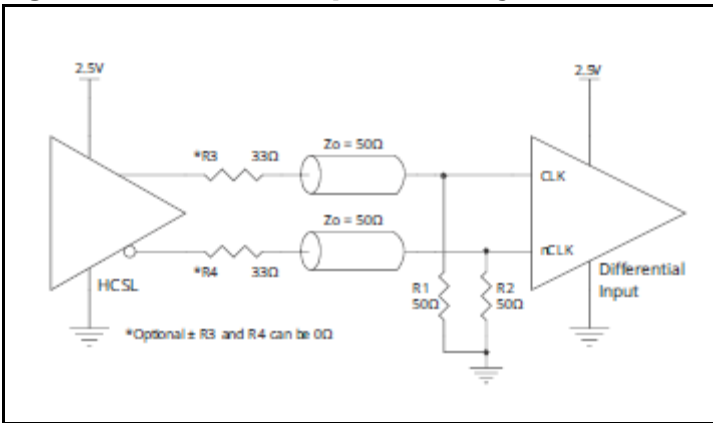

Figure 13. CLK/nCLK Input Driven by a 2.5V HCSL Driver



LVDS Driver Termination

For a general LVDS interface, the recommended value for the termination impedance (Z_T) is between 90Ω and 132Ω . The actual value should be selected to match the differential impedance (Z_0) of your transmission line. A typical point-to-point LVDS design uses a 100Ω parallel resistor at the receiver and a 100Ω differential transmission-line environment. In order to avoid any transmission-line reflection issues, the components should be surface mounted and must be placed as close to the receiver as possible. Renesas offers a full line of LVDS compliant devices with two types of output structures: current source and voltage source. The standard termination schematic as shown in Figure 14 can be used with either type of output structure. Figure 15, which can also be used with both output types, is an optional termination with center tap capacitance to help filter common mode noise. The capacitor value should be approximately 50pF . If using a non-standard termination, it is recommended to contact Renesas and confirm if the output structure is current source or voltage source type. In addition, since these outputs are LVDS compatible, the input receiver's amplitude and common-mode input range should be verified for compatibility with the output.

Figure 14. Standard LVDS Termination

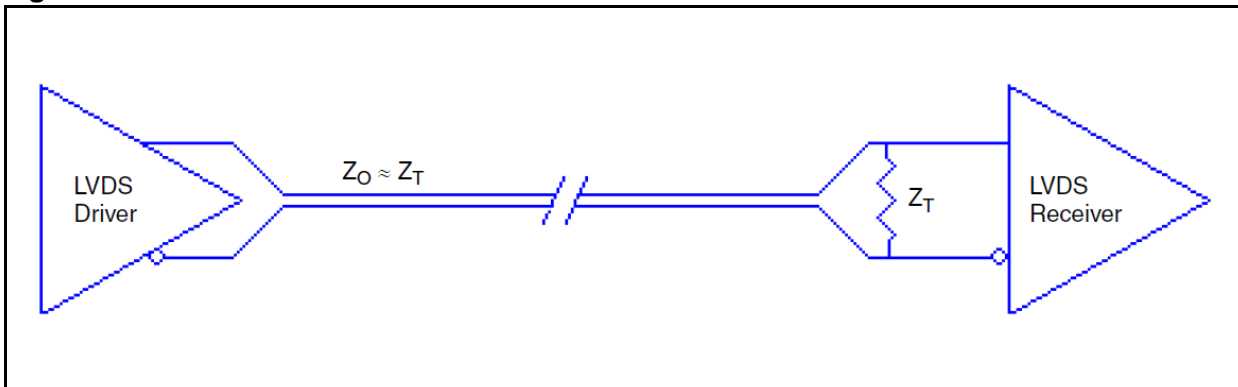
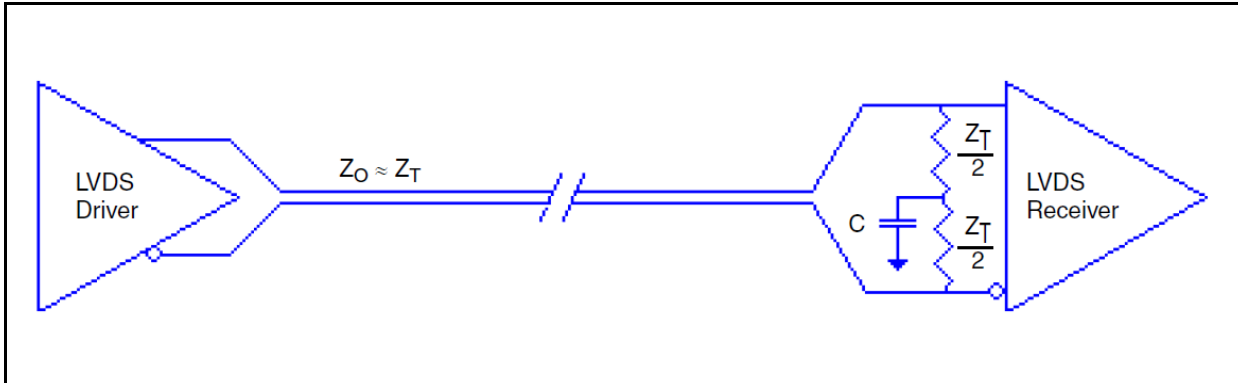

Figure 15. Optional LVDS Termination



Termination for 3.3V LVPECL Outputs

The clock topology shown below is a typical termination for LVPECL outputs. The two different terminations mentioned are recommended only as guidelines.

The differential outputs are low impedance follower outputs that generate ECL/LVPECL compatible outputs. Therefore, terminating resistors (DC current path to ground) or current sources must be used for functionality. These outputs are designed to drive 50Ω transmission lines. Matched impedance techniques should be used to maximize operating frequency and minimize signal distortion.

Figure 16. 3.3V LVPECL Output Termination

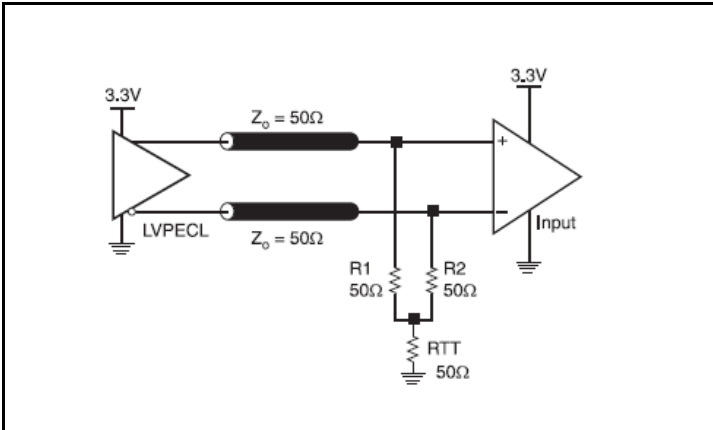
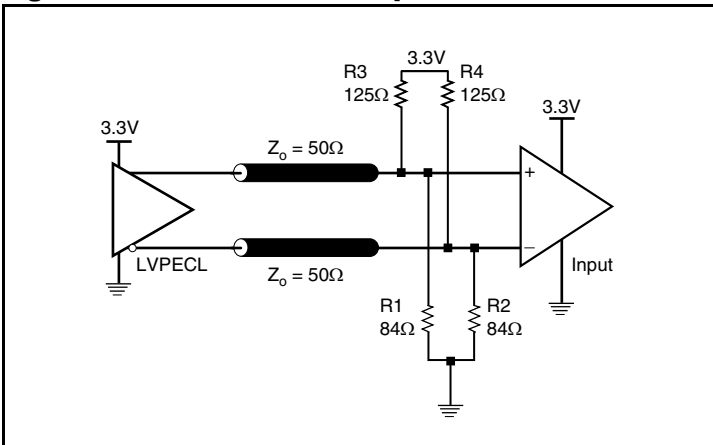

Figure 17. 3.3V LVPECL Output Termination



Termination for 2.5V LVPECL Outputs

Figure 18 and Figure 19 show examples of termination for 2.5V LVPECL driver. These terminations are equivalent to terminating 50Ω to $V_{DDO} - 2V$. For $V_{DDO} = 2.5V$, the $V_{DDO} - 2V$ is very close to ground level. The $R3$ in Figure 19 can be eliminated and the termination is shown in Figure 20.

Figure 18. 2.5V LVPECL Driver Termination Example

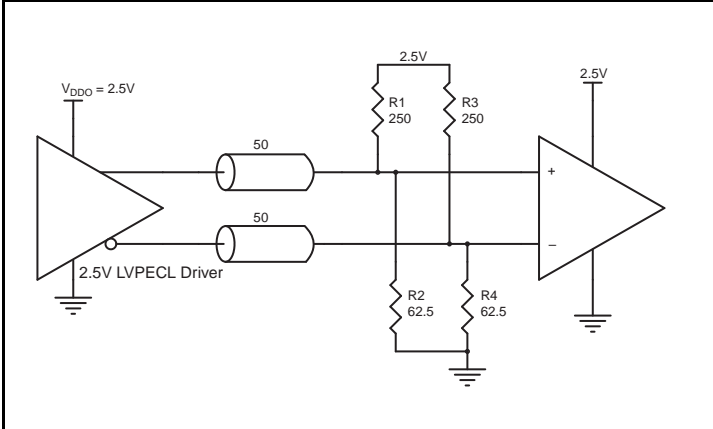

Figure 19. 2.5V LVPECL Driver Termination Example

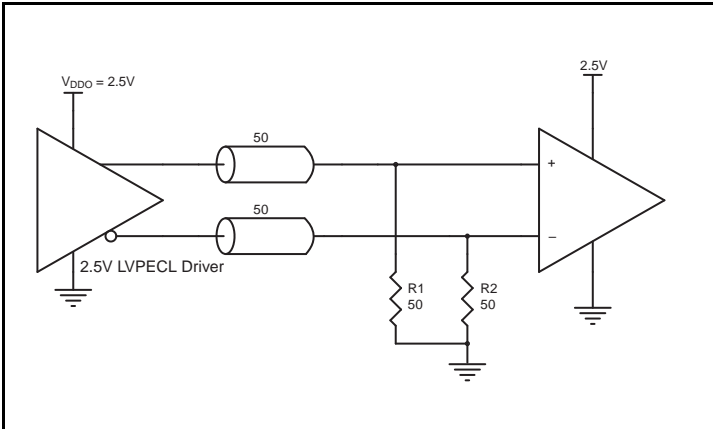
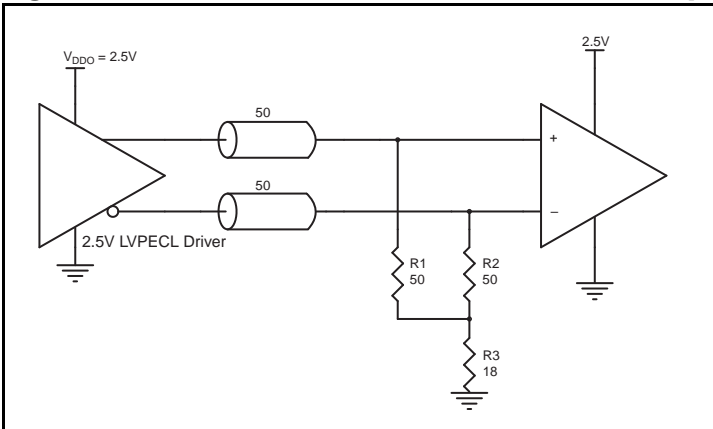

Figure 20. 2.5V LVPECL Driver Termination Example



Recommended Termination

Figure 21 is the recommended termination for applications where a point-to-point connection can be used. A point-to-point connection contains both the driver and the receiver on the same PCB. With a matched termination at the receiver, transmission-line reflections will be minimized. In addition, a series resistor (R_s) at the driver offers flexibility and can help dampen unwanted reflections. All traces should be 50Ω impedance single-ended or 100Ω differential.

Figure 21. Recommended Termination (where a point-to-point connection can be used)

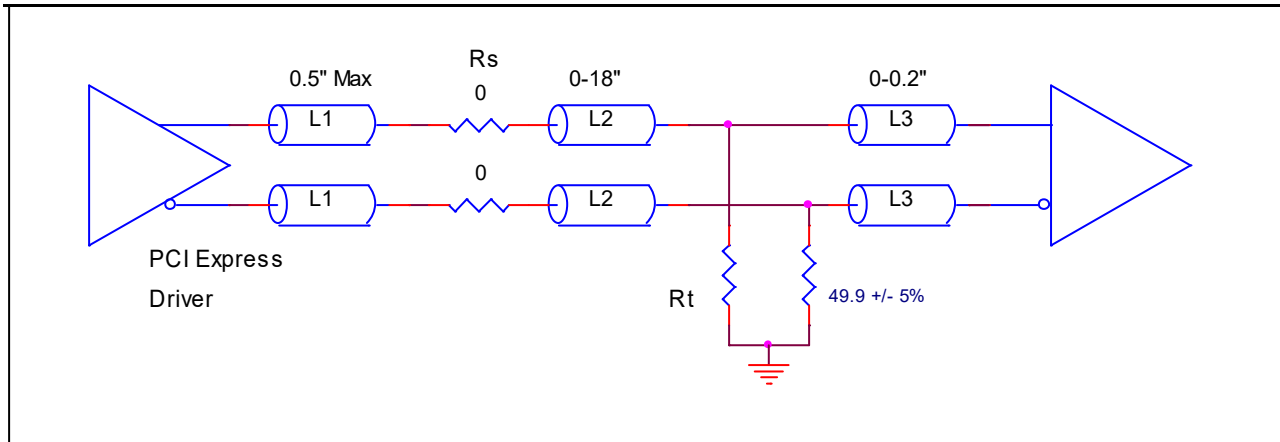

VFQFPN EPAD Thermal Release Path

In order to maximize both the removal of heat from the package and the electrical performance, a land pattern must be incorporated on the Printed Circuit Board (PCB) within the footprint of the package corresponding to the exposed metal pad or exposed heat slug on the package, as shown in Figure 22. The solderable area on the PCB, as defined by the solder mask, should be at least the same size/shape as the exposed pad/slug area on the package to maximize the thermal/electrical performance. Sufficient clearance should be designed on the PCB between the outer edges of the land pattern and the inner edges of pad pattern for the leads to avoid any shorts.

While the land pattern on the PCB provides a means of heat transfer and electrical grounding from the package to the board through a solder joint, thermal vias are necessary to effectively conduct from the surface of the PCB to the ground plane(s). The land pattern must be connected to ground through these vias. The vias act as “heat pipes”. The number of vias (i.e. “heat pipes”) are application specific and dependent upon the package power dissipation as well as electrical conductivity requirements. Thus, thermal and electrical analysis and/or testing are recommended to determine the minimum number needed. Maximum thermal and electrical performance is achieved when an array of vias is incorporated in the land pattern. It is recommended to use as many vias connected to ground as possible. It is also recommended that the via diameter should be 12 to 13mils (0.30 to 0.33mm) with 1oz copper via barrel plating. This is desirable to avoid any solder wicking inside the via during the soldering process which may result in voids in solder between the exposed pad/slug and the thermal land. Precautions should be taken to eliminate any solder voids between the exposed heat slug and the land pattern. Note: These recommendations are to be used as a guideline only. For further information, please refer to the Application Note on the Surface Mount Assembly of Amkor’s Thermally/ Electrically Enhance Lead frame Base Package, Amkor Technology.

Figure 22. P.C. Assembly for Exposed Pad Thermal Release Path – Side View (drawing not to scale)

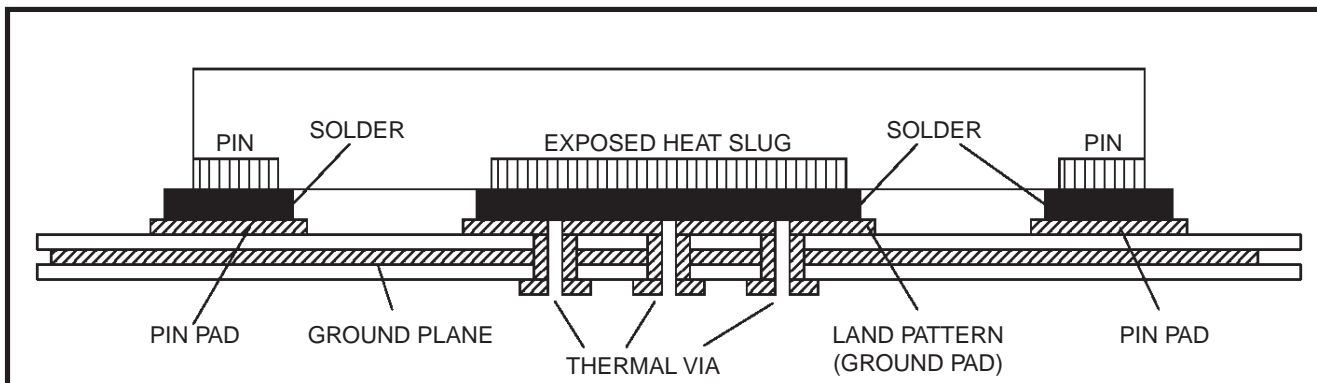

LVPECL Power Considerations

This section provides information on power dissipation and junction temperature for the 8T39210. Equations and example calculations are also provided.

LVPECL Power Considerations

1. Power Dissipation.

The total power dissipation for the 8T39210 is the sum of the core power plus the power dissipated due to outputs switching. The following is the power dissipation for $V_{DD} = 3.3V + 5\% = 3.465V$, which gives worst case results.

The Maximum current at 85°C is as follows:

$$I_{EE_MAX} = 204.614mA$$

- Power (core)_{MAX} = $I_{EE_MAX} * V_{DD_MAX} = 3.465V * 204.61mA = 708.99mW$
- Power (outputs)_{MAX} = **32mW/Loaded Output pair**

If all outputs are loaded, the total output power is $10 * 32mW = 320mW$

$$\text{Max LVPECL Power Dissipation} = 708.99mW + 320mW = \mathbf{1029mW}$$

LVC MOS Output Power Dissipation

- Static Power Dissipation:
Power (static)_{max} = $V_{DDOREF_max} * I_{DDOREF_max} = 3.465V * 2mA = 6.93mW$
($I_{DDOREF_max} = 2mA$)
- Dynamic Power Dissipation at 250MHz:
Power (Dynamic)_{max} = $C_{PD} * f_{MAX} * N * V_{DDOREF}^2 = 5.0pF * 250MHz * 1 * 3.465^2 = 15.01mW$
- LVC MOS Power Dissipation = $6.93mW + 15.01mW = 21.938mW$

$$\text{Total Power Dissipation} = 1029mW + 21.938mW = \mathbf{1051mW}$$

2. Junction Temperature.

Junction temperature, T_j , is the temperature at the junction of the bond wire and bond pad directly affects the reliability of the device. The maximum recommended junction temperature is 125°C. Limiting the internal transistor junction temperature, T_j , to 125°C ensures that the bond wire and bond pad temperature remains below 125°C.

The equation for T_j is as follows: $T_j = \theta_{JA} * Pd_total + T_A$

T_j = Junction Temperature

θ_{JA} = Junction-to-Ambient Thermal Resistance

Pd_total = Total Device Power Dissipation (example calculation is in section 1 above)

T_A = Ambient Temperature

In order to calculate junction temperature, the appropriate junction-to-ambient thermal resistance θ_{JA} must be used. Assuming no air flow and a multi-layer board, the appropriate value is 25.58°C/W per the following table. Therefore, T_j for an ambient temperature of 85°C with all outputs switching is:

$$85^\circ C + 1.051W * 25.58^\circ C/W = 111.88^\circ C. \text{ This is below the limit of } 125^\circ C.$$

This calculation is only an example. Tj will obviously vary depending on the number of loaded outputs, supply voltage, air flow and the type of board (multi-layer).

Table 25. Thermal Resistance θ_{JA} for 48-Lead VFQFN

Symbol	Parameter	Value	Unit
θ_{JA}	Theta J _A , Junction to Ambient Air Thermal Coefficient	0m/s air flow	25.58
		1m/s air flow	21.78
		2m/s air flow	20.35
θ_{JB}	Theta J _B , Junction to Board Thermal Coefficient	2.82	°C/W

LVPECL Power Considerations (Application Frequency 156.25MHz)

This section provides information on power dissipation and junction temperature for the 8T39210. Equations and example calculations are also provided.

LVPECL Power Considerations

1. Power Dissipation.

The total power dissipation for the 8T39210 is the sum of the core power plus the power dissipated due to outputs switching. The following is the power dissipation for $V_{DD} = 3.3V + 5\% = 3.465V$, which gives worst case results.

The Maximum current at 85°C is as follows:

$$I_{EE_MAX} = 98.961mA$$

- Power (core)_{MAX} = $I_{EE_MAX} * V_{DD_MAX} = 3.465V * 98.961mA = 342.9mW$
- Power (outputs)_{MAX} = **32mW/Loaded Output pair**

If all outputs are loaded, the total output power is $10 * 32mW = 320mW$

$$\text{Max LVPECL Power Dissipation} = 342.9mW + 320mW = \mathbf{662.9mW}$$

LVC MOS Output Power Dissipation

- Static Power Dissipation:
Power (static)_{max} = $V_{DDOREF_max} * I_{DDOREF_max} = 3.465V * 2mA = 6.93mW$
($I_{DDOREF_max} = 2mA$)
- Dynamic Power Dissipation at 250MHz:
Power (Dynamic)_{max} = $C_{PD} * f_{MAX} * N * V_{DDOREF}^2 = 5.0pF * 156.25MHz * 1 * 3.465^2 = 9.38mW$
- LVC MOS Power Dissipation = $6.93mW + 9.38mW = 16.31mW$

$$\text{Total Power Dissipation} = 662.9mW + 16.31mW = \mathbf{679.21mW}$$

2. Junction Temperature.

Junction temperature, Tj, is the temperature at the junction of the bond wire and bond pad directly affects the reliability of the device. The maximum recommended junction temperature is 125°C. Limiting the internal transistor junction temperature, Tj, to 125°C ensures that the bond wire and bond pad temperature remains below 125°C.

The equation for Tj is as follows: $Tj = \theta_{JA} * Pd_total + T_A$

Tj = Junction Temperature

θ_{JA} = Junction-to-Ambient Thermal Resistance

P_{d_total} = Total Device Power Dissipation (example calculation is in section 1 above)

T_A = Ambient Temperature

In order to calculate junction temperature, the appropriate junction-to-ambient thermal resistance θ_{JA} must be used. Assuming no air flow and a multi-layer board, the appropriate value is 25.58°C/W per the following table. Therefore, T_J for an ambient temperature of 85°C with all outputs switching is:

$85^\circ\text{C} + 0.679\text{W} * 25.58^\circ\text{C/W} = 102.37^\circ\text{C}$. This is below the limit of 125°C.

This calculation is only an example. T_J will obviously vary depending on the number of loaded outputs, supply voltage, air flow and the type of board (multi-layer).

Table 26. Thermal Resistance θ_{JA} for 48-Lead VFQFN

Symbol	Parameter	Value	Unit
θ_{JA}	Theta J_A , Junction to Ambient Air Thermal Coefficient	0m/s air flow	25.58
		1m/s air flow	21.78
		2m/s air flow	20.35
θ_{JB}	Theta J_B , Junction to Board Thermal Coefficient	2.82	°C/W

3. Calculations and Equations.

The purpose of this section is to calculate the power dissipation for the LVPECL output pairs.

LVPECL output driver circuit and termination are shown in Figure 23.

Figure 23. LVPECL Driver Circuit and Termination

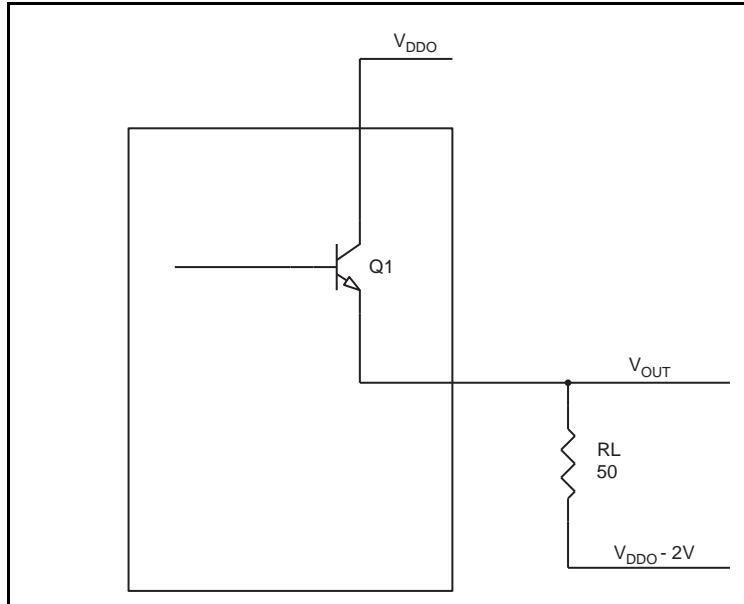

To calculate power dissipation per output pair due to loading, use the following equations which assume a 50Ω load, and a termination voltage of $V_{DDO} - 2V$.

- For logic high, $V_{OUT} = V_{OH_MAX} = V_{DDO_MAX} - 0.8V$
 $(V_{DDO_MAX} - V_{OH_MAX}) = 0.8V$
- For logic low, $V_{OUT} = V_{OL_MAX} = V_{DDO_MAX} - 1.6V$
 $(V_{DDO_MAX} - V_{OL_MAX}) = 1.6V$

Pd_H is power dissipation when the output drives high.

Pd_L is the power dissipation when the output drives low.

$$Pd_H = [(V_{OH_MAX} - (V_{DDO_MAX} - 2V))/R_L] * (V_{DDO_MAX} - V_{OH_MAX}) = [(2V - (V_{DDO_MAX} - V_{OH_MAX}))/R_L] * (V_{DDO_MAX} - V_{OH_MAX}) = [(2V - 0.8V)/50\Omega] * 0.8V = \mathbf{19.20mW}$$

$$Pd_L = [(V_{OL_MAX} - (V_{DDO_MAX} - 2V))/R_L] * (V_{DDO_MAX} - V_{OL_MAX}) = [(2V - (V_{DDO_MAX} - V_{OL_MAX}))/R_L] * (V_{DDO_MAX} - V_{OL_MAX}) = [(2V - 1.6V)/50\Omega] * 1.6V = \mathbf{12.80mW}$$

Total Power Dissipation per output pair = $Pd_H + Pd_L = 32mW$

LVDS Power Considerations

This section provides information on power dissipation and junction temperature for the 8T39210. Equations and example calculations are also provided.

LVDS Power Considerations

1. Power Dissipation.

The total power dissipation for the 8T39210 is the sum of the core power plus the power dissipated due to outputs switching. The following is the power dissipation for $V_{DD} = 3.3V + 5\% = 3.465V$, which gives worst case results.

The Maximum current at $85^\circ C$ is as follows:

$$I_{DD_MAX} = 37mA$$

$$I_{DDO_MAX} = 189mA$$

$$\text{Max LVDS Power Dissipation} = V_{DD_MAX} * (I_{DD_MAX} + I_{DDO_MAX}) = 3.465V * (37mA + 189mA) = \mathbf{782.55mW}$$

LVC MOS Output Power Dissipation

- Static Power Dissipation:
 $\text{Power (static)}_{max} = V_{DDOREF_max} * I_{DDOREF_max} = 3.465V * 2mA = \mathbf{6.93mW}$
 $(I_{DDOREF_max} = 2mA)$
- Dynamic Power Dissipation at 250MHz:
 $\text{Power (Dynamic)}_{max} = C_{PD} * f_{MAX} * N * V_{DDOREF}^2 = 5.0pF * 250MHz * 1 * 3.465^2 = \mathbf{15.01mW}$
- LVC MOS Power Dissipation = $6.93mW + 15.01mW = \mathbf{21.938mW}$

$$\text{Total Power Dissipation} = 782.55mW + 21.938mW = \mathbf{804.49mW}$$

2. Junction Temperature.

Junction temperature, T_j , is the temperature at the junction of the bond wire and bond pad directly affects the reliability of the device. The maximum recommended junction temperature is $125^\circ C$. Limiting the internal transistor junction temperature, T_j , to $125^\circ C$ ensures that the bond wire and bond pad temperature remains below $125^\circ C$.

The equation for T_j is as follows: $T_j = \theta_{JA} * Pd_total + T_A$

T_j = Junction Temperature

θ_{JA} = Junction-to-Ambient Thermal Resistance

Pd_{total} = Total Device Power Dissipation (example calculation is in section 1 above)

T_A = Ambient Temperature

In order to calculate junction temperature, the appropriate junction-to-ambient thermal resistance θ_{JA} must be used. Assuming no air flow and a multi-layer board, the appropriate value is 25.58°C/W per Table 25. Therefore, T_j for an ambient temperature of 85°C with all outputs switching is:

$$85^{\circ}\text{C} + 0.805\text{W} * 25.58^{\circ}\text{C}/\text{W} = 105.58^{\circ}\text{C}. \text{ This is below the limit of } 125^{\circ}\text{C}.$$

This calculation is only an example. T_j will obviously vary depending on the number of loaded outputs, supply voltage, air flow and the type of board (multi-layer).

LVDS Power Considerations (Application Frequency 156.25MHz)

This section provides information on power dissipation and junction temperature for the 8T39210. Equations and example calculations are also provided.

LVDS Power Considerations

1. Power Dissipation.

The total power dissipation for the 8T39210 is the sum of the core power plus the power dissipated due to outputs switching. The following is the power dissipation for $V_{DD} = 3.3\text{V} + 5\% = 3.465\text{V}$, which gives worst case results.

The Maximum current at 85°C is as follows:

$$I_{DD_MAX} = 36\text{mA}$$

$$I_{DDO_MAX} = 105\text{mA}$$

$$\text{Max LVDS Power Dissipation} = V_{DD_MAX} * (I_{DD_MAX} + I_{DDO_MAX}) = 3.465\text{V} * (36\text{mA} + 105\text{mA}) = \mathbf{487.67\text{mW}}$$

LVC MOS Output Power Dissipation

- Static Power Dissipation:

$$\text{Power (static)}_{max} = V_{DDOREF_max} * I_{DDOREF_max} = 3.465\text{V} * 2\text{mA} = \mathbf{6.93\text{mW}}$$

($I_{DDOREF_max} = 2\text{mA}$)

- Dynamic Power Dissipation at 156.25MHz:

$$\text{Power (Dynamic)}_{max} = C_{PD} * f_{MAX} * N * V_{DDOREF}^2 = 5.0\text{pF} * 156.25\text{MHz} * 1 * 3.465^2 = \mathbf{9.38\text{mW}}$$

- LVC MOS Power Dissipation = 6.93mW + 9.38mW = **16.31mW**

$$\text{Total Power Dissipation} = 487.67\text{mW} + 16.31\text{mW} = \mathbf{503.98\text{mW}}$$

2. Junction Temperature.

Junction temperature, T_j , is the temperature at the junction of the bond wire and bond pad directly affects the reliability of the device. The maximum recommended junction temperature is 125°C. Limiting the internal transistor junction temperature, T_j , to 125°C ensures that the bond wire and bond pad temperature remains below 125°C.

The equation for T_j is as follows: $T_j = \theta_{JA} * Pd_{total} + T_A$

T_j = Junction Temperature

θ_{JA} = Junction-to-Ambient Thermal Resistance

Pd_{total} = Total Device Power Dissipation (example calculation is in section 1 above)

T_A = Ambient Temperature

In order to calculate junction temperature, the appropriate junction-to-ambient thermal resistance θ_{JA} must be used. Assuming no air flow and a multi-layer board, the appropriate value is 25.58°C/W per Table 25. Therefore, T_j for an ambient temperature of 85°C with all outputs switching is:

$$85^{\circ}\text{C} + 0.504\text{W} * 25.58^{\circ}\text{C}/\text{W} = 97.9^{\circ}\text{C}. \text{ This is below the limit of } 125^{\circ}\text{C}.$$

This calculation is only an example. T_j will obviously vary depending on the number of loaded outputs, supply voltage, air flow and the type of board (multi-layer).

HCSL Power Considerations

This section provides information on power dissipation and junction temperature for the 8T39210. Equations and example calculations are also provided.

HCSL Power Considerations

1. Power Dissipation.

The total power dissipation for the 8T39210 is the sum of the core power plus the power dissipated due to outputs switching. The following is the power dissipation for $V_{DD} = 3.3\text{V} + 5\% = 3.465\text{V}$, which gives worst case results.

The Maximum current at 85°C is as follows:

$$I_{DD_MAX} = 38\text{mA}$$

$$I_{DDO_MAX} = 118\text{mA} \text{ (application frequency} = 750\text{MHz)}$$

- Power (core)_{MAX} = $V_{DD_MAX} * (I_{DD_MAX} + I_{DDO_MAX}) = 3.465\text{V} * (38\text{mA} + 118\text{mA}) = \mathbf{541.92\text{mW}}$
- Power (outputs)_{MAX} = **44.5mW/Loaded Output pair**

If all outputs are loaded, the total power is $10 * 44.5\text{mW} = \mathbf{445\text{mW}}$

$$\text{Max HCSL Power Dissipation} = 541.92\text{mW} + 445\text{mW} = \mathbf{986.92\text{mW}}$$

LVC MOS Output Power Dissipation

- Static Power Dissipation:
Power (static)_{max} = $V_{DDOREF_max} * I_{DDOREF_max} = 3.465\text{V} * 2\text{mA} = \mathbf{6.93\text{mW}}$
($I_{DDOREF_max} = 2\text{mA}$)
- Dynamic Power Dissipation at 250MHz:
Power (Dynamic)_{max} = $C_{PD} * f_{MAX} * N * V_{DDOREF}^2 = 5.0\text{pF} * 250\text{MHz} * 1 * 3.465^2 = \mathbf{15.01\text{mW}}$
- LVC MOS Power Dissipation = $6.93\text{mW} + 15.01\text{mW} = \mathbf{21.938\text{mW}}$

$$\text{Total Power Dissipation} = 986.92\text{mW} + 21.94\text{mW} = \mathbf{1008.85\text{mW}}$$

2. Junction Temperature.

Junction temperature, T_j , is the temperature at the junction of the bond wire and bond pad directly affects the reliability of the device. The maximum recommended junction temperature is 125°C. Limiting the internal transistor junction temperature, T_j , to 125°C ensures that the bond wire and bond pad temperature remains below 125°C.

The equation for T_j is as follows: $T_j = \theta_{JA} * Pd_total + T_A$

T_j = Junction Temperature

θ_{JA} = Junction-to-Ambient Thermal Resistance

Pd_total = Total Device Power Dissipation (example calculation is in section 1 above)

T_A = Ambient Temperature

In order to calculate junction temperature, the appropriate junction-to-ambient thermal resistance θ_{JA} must be used. Assuming no air flow and a multi-layer board, the appropriate value is 25.58°C/W per Table 25. Therefore, Tj for an ambient temperature of 85°C with all outputs switching is:

$$85^{\circ}\text{C} + 1.009\text{W} * 25.58^{\circ}\text{C}/\text{W} = 110.81^{\circ}\text{C}. \text{ This is below the limit of } 125^{\circ}\text{C}.$$

This calculation is only an example. Tj will obviously vary depending on the number of loaded outputs, supply voltage, air flow and the type of board (multi-layer).

HCSL Power Considerations (Application Frequency 156.25MHz)

This section provides information on power dissipation and junction temperature for the 8T39210. Equations and example calculations are also provided.

HCSL Power Considerations

1. Power Dissipation.

The total power dissipation for the 8T39210 is the sum of the core power plus the power dissipated due to outputs switching. The following is the power dissipation for $V_{DD} = 3.3\text{V} + 5\% = 3.465\text{V}$, which gives worst case results.

The Maximum current at 85°C is as follows:

$$I_{DD_MAX} = 38\text{mA}$$

$$I_{DDO_MAX} = 48\text{mA} \text{ (Application Frequency = 156.25MHz)}$$

- Power (core)_{MAX} = $V_{DD_MAX} * (I_{DD_MAX} + I_{DDO_MAX}) = 3.465\text{V} * (38\text{mA} + 48\text{mA}) = \mathbf{300.34\text{mW}}$
- Power (outputs)_{MAX} = **44.5mW/Loaded Output pair**

If all outputs are loaded, the total power is $10 * 44.5\text{mW} = \mathbf{445\text{mW}}$

$$\text{Max HCSL Power Dissipation} = 300.34\text{mW} + 445\text{mW} = \mathbf{745.34\text{mW}}$$

LVC MOS Output Power Dissipation

- Static Power Dissipation:
Power (static)_{max} = $V_{DDOREF_max} * I_{DDOREF_max} = 3.465\text{V} * 2\text{mA} = \mathbf{6.93\text{mW}}$
($I_{DDOREF_max} = 2\text{mA}$)
- Dynamic Power Dissipation at 156.25MHz:
Power (Dynamic)_{max} = $C_{PD} * f_{MAX} * N * V_{DDOREF}^2 = 5.0\text{pF} * 156.25\text{MHz} * 1 * 3.465^2 = \mathbf{9.38\text{mW}}$
- LVC MOS Power Dissipation = $6.93\text{mW} + 9.38\text{mW} = \mathbf{16.31\text{mW}}$

$$\text{Total Power Dissipation} = 745.34\text{mW} + 16.31\text{mW} = \mathbf{761.65\text{mW}}$$

2. Junction Temperature.

Junction temperature, Tj, is the temperature at the junction of the bond wire and bond pad directly affects the reliability of the device. The maximum recommended junction temperature is 125°C. Limiting the internal transistor junction temperature, Tj, to 125°C ensures that the bond wire and bond pad temperature remains below 125°C.

The equation for Tj is as follows: $T_j = \theta_{JA} * Pd_total + T_A$

Tj = Junction Temperature

θ_{JA} = Junction-to-Ambient Thermal Resistance

Pd_{total} = Total Device Power Dissipation (example calculation is in section 1 above)

T_A = Ambient Temperature

In order to calculate junction temperature, the appropriate junction-to-ambient thermal resistance θ_{JA} must be used. Assuming no air flow and a multi-layer board, the appropriate value is 25.58°C/W per Table 25. Therefore, T_j for an ambient temperature of 85°C with all outputs switching is:

$$85^{\circ}\text{C} + 0.761\text{W} * 25.58^{\circ}\text{C}/\text{W} = 104.6^{\circ}\text{C}.$$

This is below the limit of 125°C.

This calculation is only an example. T_j will obviously vary depending on the number of loaded outputs, supply voltage, air flow and the type of board (multi-layer).

3. Calculations and Equations.

The purpose of this section is to calculate power dissipation on the IC per HCSL output pair.

HCSL output driver circuit and termination are shown in Figure 24.

Figure 24. HCSL Driver Circuit and Termination

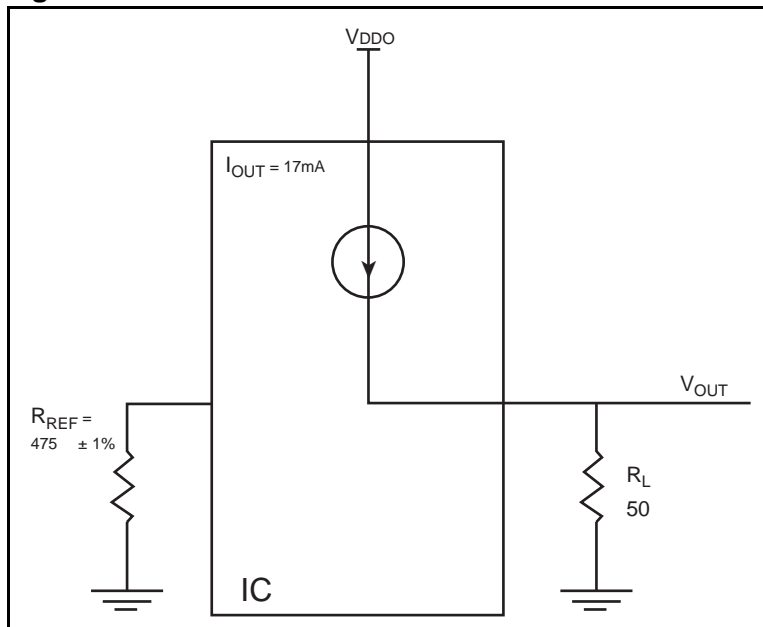

HCSL is a current steering output which sources a maximum of 17mA of current per output. To calculate worst case on-chip power dissipation, use the following equations which assume a 50Ω load to ground.

The highest power dissipation occurs when V_{DDO_MAX} .

$$\text{Power} = (V_{DDO_MAX} - V_{OUT}) * I_{OUT},$$

$$\text{since } V_{OUT} = I_{OUT} * R_L$$

$$= (V_{DDO_MA} - I_{OUT} * R_L) * I_{OUT}$$

$$= (3.465\text{V} - 17\text{mA} * 50\Omega) * 17\text{mA}$$

Total Power Dissipation per output pair = **44.5mW**

Reliability Information

See Table 25.

Transistor Count

The transistor count for 8T39210 is: 8654

Package Outline Drawings

The package outline drawings are located at the end of this document and are accessible from the Renesas website. The package information is the most current data available and is subject to change without revision of this document.

Ordering Information

Part Number	Marking	Package Description	Carrier Type	Temperature Range
8T39210NLGI	IDT8T39210NLGI	48-VFQFPN, Lead-Free	Tray	-40°C to 85°C
8T39210NLGI8	IDT8T39210NLGI	48-VFQFPN, Lead-Free	Tape and Reel	-40°C to 85°C

Revision History

Revision Date	Description of Change
February 2, 2023	<ul style="list-style-type: none"> ▪ Updated Recommended Termination section. ▪ Updated Rs value in Figure 21 to '0' from '0 to 33'.
February 22, 2021	<ul style="list-style-type: none"> ▪ Updated footnote [p] in Table 22, Table 23, and Table 24
February 19, 2021	<ul style="list-style-type: none"> ▪ Increased maximum frequency for HCSL output
December 16, 2019	<ul style="list-style-type: none"> ▪ Corrected a calculation mistake in LVDS Power Considerations (Application Frequency 156.25MHz) ▪ Dynamically linked the package outline drawings to the document; however, no technical changes.
December 6, 2019	Added package outline drawings.
November 22, 2019	Initial release.

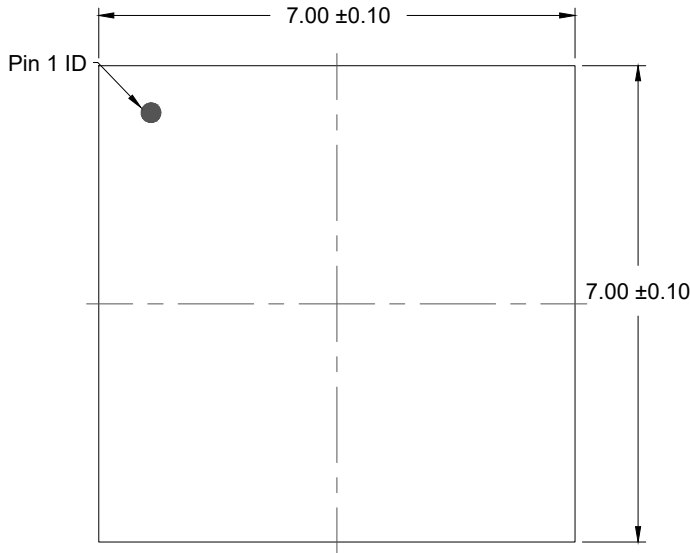

TOP VIEW

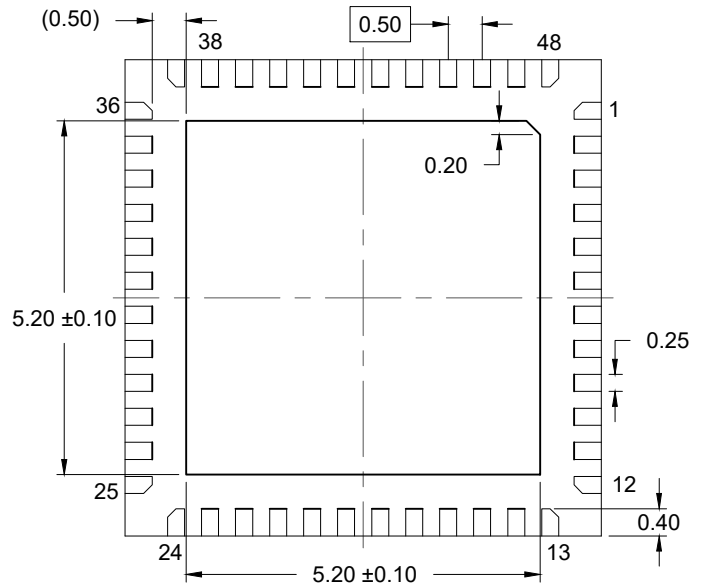

BOTTOM VIEW

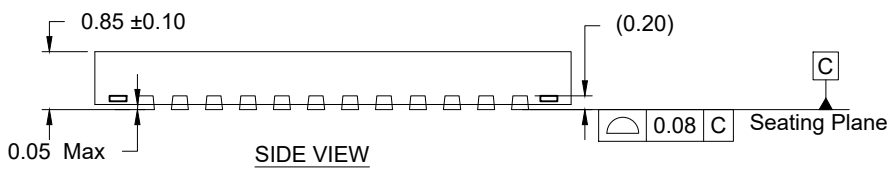

SIDE VIEW

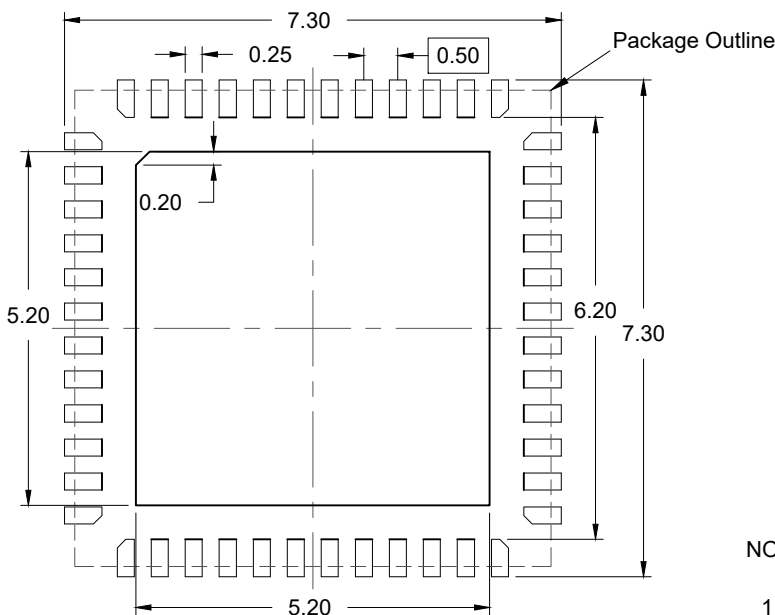

RECOMMENDED LAND PATTERN
(PCB Top View, NSMD Design)

NOTES:

1. JEDEC compatible.
2. All dimensions are in mm and angles are in degrees.
3. Use ± 0.05 mm for the non-toleranced dimensions.
4. Numbers in () are for references only.

IMPORTANT NOTICE AND DISCLAIMER

RENESAS ELECTRONICS CORPORATION AND ITS SUBSIDIARIES (“RENESAS”) PROVIDES TECHNICAL SPECIFICATIONS AND RELIABILITY DATA (INCLUDING DATASHEETS), DESIGN RESOURCES (INCLUDING REFERENCE DESIGNS), APPLICATION OR OTHER DESIGN ADVICE, WEB TOOLS, SAFETY INFORMATION, AND OTHER RESOURCES “AS IS” AND WITH ALL FAULTS, AND DISCLAIMS ALL WARRANTIES, EXPRESS OR IMPLIED, INCLUDING, WITHOUT LIMITATION, ANY IMPLIED WARRANTIES OF MERCHANTABILITY, FITNESS FOR A PARTICULAR PURPOSE, OR NON-INFRINGEMENT OF THIRD-PARTY INTELLECTUAL PROPERTY RIGHTS.

These resources are intended for developers who are designing with Renesas products. You are solely responsible for (1) selecting the appropriate products for your application, (2) designing, validating, and testing your application, and (3) ensuring your application meets applicable standards, and any other safety, security, or other requirements. These resources are subject to change without notice. Renesas grants you permission to use these resources only to develop an application that uses Renesas products. Other reproduction or use of these resources is strictly prohibited. No license is granted to any other Renesas intellectual property or to any third-party intellectual property. Renesas disclaims responsibility for, and you will fully indemnify Renesas and its representatives against, any claims, damages, costs, losses, or liabilities arising from your use of these resources. Renesas' products are provided only subject to Renesas' Terms and Conditions of Sale or other applicable terms agreed to in writing. No use of any Renesas resources expands or otherwise alters any applicable warranties or warranty disclaimers for these products.

(Disclaimer Rev.1.01 Jan 2024)

Corporate Headquarters

TOYOSU FORESIA, 3-2-24 Toyosu,
Koto-ku, Tokyo 135-0061, Japan
www.renesas.com

Trademarks



Renesas and the Renesas logo are trademarks of Renesas Electronics Corporation. All trademarks and registered trademarks are the property of their respective owners.

Contact Information

For further information on a product, technology, the most up-to-date version of a document, or your nearest sales office, please visit www.renesas.com/contact-us/.

Looking for pricing, stock, or lifecycle information?

Click below to explore more details on WIN SOURCE:

-  [View 8T39210NLG18 on WIN SOURCE](#)
-  [Renesas Electronics America](#) Information

Optimize Your Supply Chain with WIN SOURCE Solutions

-  Global Sourcing Solution
-  Obsolete Management
-  Cost Control Management
-  Shortage Management
-  Alternative Solution
-  Excess Inventory Management