



**THE DATASHEET OF
EVAL-AD4003FMCZ**





Easy to Use **AD4000** Series 16-/18-/20-Bit Precision SAR ADCs User Guide

UG-1042

One Technology Way • P.O. Box 9106 • Norwood, MA 02062-9106, U.S.A. • Tel: 781.329.4700 • Fax: 781.461.3113 • www.analog.com

Evaluation Board for the **AD4000** Series 16-/18-/20-Bit Precision SAR ADCs

FEATURES

- Fully featured evaluation board for 10-lead precision ADCs
- Versatile analog signal conditioning circuitry
- On-board reference, reference buffers, and ADC drivers
- PC software for control and data analysis of time and frequency domain
- System demonstration platform-compatible (**SDP-H1**)

EVALUATION BOARD KIT CONTENTS

- AD4000/AD4001/AD4002/AD4003/AD4020** evaluation board (see Table 7)
- 12 V wall adapter power supply

EQUIPMENT NEEDED

- PC running Windows 7 or Windows 10
- SDP-H1** board (**EVAL-SDP-CH1Z**) or FMC-compatible controller board
- Precision signal source
- Cable (SMA input to evaluation board)
- One end of cable is standard USB A and other end of cable is mini-B USB
- Band-pass filter suitable for 16-bit, 18-bit, and 20-bit testing (value based on signal frequency)
- AD40XX** evaluation software

GENERAL DESCRIPTION

The **AD4000/AD4001/AD4002/AD4003/AD4020** family of evaluation boards enable quick, simplified evaluation of the **AD4000** family of 16-/18-/20-bit, precision successive approximation register (SAR) analog-to-digital converters (ADCs). The **AD4000/AD4001/AD4002/AD4003/AD4020** are low power, 16-bit/18-bit/20-bit, precision SAR ADCs that offer high performance with throughputs up to 2 MSPS (1.8 MSPS for the **AD4020**). The evaluation board demonstrates the performance of the **AD4000/AD4001/AD4002/AD4003/AD4020** family of

ADCs and provides a simplified interface for a variety of system applications.

The **EVAL-AD4000FMCZ/EVAL-AD4001FMCZ/EVAL-AD4002FMCZ/EVAL-AD4003FMCZ/EVAL-AD4020FMCZ** evaluation boards, accessible from the **EVAL-AD400x-FMCZ** product page, (see Figure 1) are ideal for use with the Analog Devices, Inc., high speed system demonstration platform (**SDP-H1**). These evaluation boards interface to the **SDP-H1** board via a field-programmable gate array (FPGA) mezzanine card (FMC) low pin count (LPC) connector.

On-board components include a high precision buffered band gap 5.0 V reference (**ADR4550**), a reference buffer (**ADA4807-1**), a common-mode buffer (**ADA4807-1**), a signal conditioning circuit with two op amps (**ADA4807-1**), and a power supply to derive the necessary voltage levels to supply all voltage needs.

The **EVAL-AD4000FMCZ**, **EVAL-AD4001FMCZ**, **EVAL-AD4002FMCZ**, **EVAL-AD4003FMCZ**, and **EVAL-AD4020FMCZ** are populated with the **AD4000**, **AD4001**, **AD4002**, **AD4003**, and **AD4020**, respectively. However, these boards can be used to evaluate the performance of the **AD4004**, **AD4005**, **AD4006**, **AD4007**, **AD4008**, **AD4010**, **AD4011**, **AD4021**, and **AD4022** by limiting the sample rate in the evaluation software to the maximum sample rate of the specific ADC. For example, the **AD4000** on the **EVAL-AD4000FMCZ** can be used to evaluate the performance of the **AD4004** if the sample rate is limited to 1 MSPS. See the data sheet of each product for the corresponding evaluation board.

Full descriptions of these products are available in their respective data sheets, which must be consulted when using the corresponding evaluation board. Table 7 shows the models of the **AD4000/AD4001/AD4002/AD4003/AD4020** evaluation boards.

TABLE OF CONTENTS

Features	1	Establishing Hardware Connection	12
Evaluation Board Kit Contents	1	Overview of the Front Panel	12
Equipment Needed	1	Configure Tab	13
General Description	1	Waveform Tab View	15
Revision History	2	Histogram Tab View	16
Evaluation Board Photograph.....	4	FFT Tab View.....	17
Evaluation Board Hardware.....	5	Summary Tab View.....	18
Setting Up the Evaluation Board.....	5	Graph Viewing Controls	19
Power Supplies	5	Saving and Loading Sessions	19
Reference, Reference Buffer, and Common-Mode Buffer	5	Offline Mode.....	19
SDP-H1 Controller Board	6	Troubleshooting.....	20
Solder Links.....	6	Software	20
Analog Inputs.....	7	Hardware	20
Getting Started	8	Evaluation Board Schematics and Artwork.....	21
Software Installation Procedures.....	8	Ordering Information.....	28
Evaluation Hardware Setup Procedures.....	11	Evaluation Board Bill of Materials	28
Software Operation	12		
Running the Evaluation Software.....	12		

REVISION HISTORY

11/2019—Rev. H to Rev. I

Changes to General Description Section	1
Changes to Table 4.....	7

8/2019—Rev. G to Rev. H

Changed EVAL-SDP-CH1Z to SDP-H1	Throughout
Changes to Equipment Needed Section and General Description Section.....	1
Added Figure 1 Caption.....	4
Added Identifying the Evaluation Board Section	5
Changes to Power Supplies Section.....	5
Deleted Evaluation Board Software Section, Installing the Software Section, and Installation Steps Section.....	6
Changes to SDP-H1 Controller Board Section, and Table 2	6
Added Endnote 1 to Table 2.....	6
Changes to Table 4 and Analog Inputs Section	7
Deleted Board Operation/Connection Sequence Section, Running the Software with the Hardware Connected Section, and Figure 16 to Figure 18; Renumbered Sequentially	8
Added Getting Started Section, Software Installation Procedures Section, and Installing the AD40XX Evaluation Software Section	8
Changes to Figure 4 to Figure 6.....	8
Added Installing the SDP-H1 Board Drivers Section, Figure 12; Renumbered Sequentially.....	9

Changes to Figure 7 to Figure 9, Figure 10 Caption, and Figure 11	9
Deleted Figure 20.....	10
Changes to Figure 13, Figure 14, Figure 15, and Figure 16 Caption	10
Deleted Waveform Capture Section.....	11
Added Uninstalling the Software Section, Evaluation Hardware Setup Procedures Section, Connecting the Evaluation Hardware to a PC Section, and Verifying Hardware Connection Section	11
Deleted AC Testing—Histogram Section and DC Testing—Histogram Section	12
Added Running the Evaluation Software Section, Establishing Hardware Connection Section, and Overview of the Front Panel Section, and Figure 18.....	12
Changes to Software Operation Section, Figure 17, and File Menu Section	12
Deleted AC Testing—FFT Capture Section.....	13
Added Edit Menu Section, Help Menu Section, Display Tabs Section, Single Capture Button Section, Continuous Capture Button Section, Samples Dropdown List Section, Status Bar Section, and Configure Tab Section.....	13
Deleted Summary Tab Section	14
Added Waveform Tab View Section	15
Changes to Figure 19.....	15
Added Histogram Tab View Section.....	16
Changes to Figure 20.....	16

Added FFT Tab View Section.....17
 Changes to Figure 2117
 Added Summary Tab View Section19
 Changes to Figure 2219
 Moved Table 5 and Figure 2320
 Added Graph Viewing Controls Section, Saving and Loading Sessions Section, Offline Mode Section20
 Changes to Software Section21
 Changes to Figure 2422
 Changes to Figure 2523
 Changes to Figure 2624
 Deleted Related Links Table.....25
 Changes to Figure 27 Caption25
 Changes to Figure 28 Caption and Figure 29 Caption26
 Changes to Figure 30 Caption and Figure 31 Caption27
 Changes to Figure 32 Caption28
 Changed Products on this Evaluation Board Section to Ordering Information Section and AD4000/AD4001/AD4002/AD4003/AD4020 Evaluation Board Bill of Materials Section to Evaluation Board Bill of Materials Section29
 Changes to Table 730

12/2018—Rev. F to Rev. G
 Change to Solder Links Section5
 Added Figure 3 and Table 4; Renumbered Sequentially5

6/2018—Rev. E to Rev. F
 Change to Figure 24
 Changes to Table 523

1/2018—Rev. D to Rev. E
 Added AD4002, AD4006, AD4010..... Throughout
 Changes to Figure 2 and Setting Up the Evaluation Board Section4
 Changes to Table 626

9/2017—Rev. C to Rev. D
 Change to General Description Section..... 1

7/2017—Rev. B to Rev. C
 Added AD4020..... Universal
 Added EVAL-AD4020FMCZ Universal
 Changes to User Guide Title and Subject, Evaluation Board Kit Contents Section, and General Description Section 1
 Moved Evaluation Board Photograph Section..... 3
 Changes to Figure 2 and Setting Up the Evaluation Board Section 4
 Changes to Table 3 5
 Changes to Figure 18 9
 Changes to Description of the User Panel Section 10
 Changes to Table 6 25

1/2017—Rev. A to Rev. B
 Added AD4001 Universal
 Changes to User Guide Title.....Throughout
 Changes to User Guide Subject Line 1
 Changes to Figure 2 3
 Changes to Table 3 4
 Moved Troubleshooting Section 15
 Changes to Table 5 22
 Changes to Table 6 23

11/2016—Rev. 0 to Rev. A
 Added Figure 1, Renumbered Sequentially 1
 Changes to General Description Section 1
 Changes to Setting Up the Evaluation Board 3

10/2016—Revision 0: Initial Version

EVALUATION BOARD PHOTOGRAPH

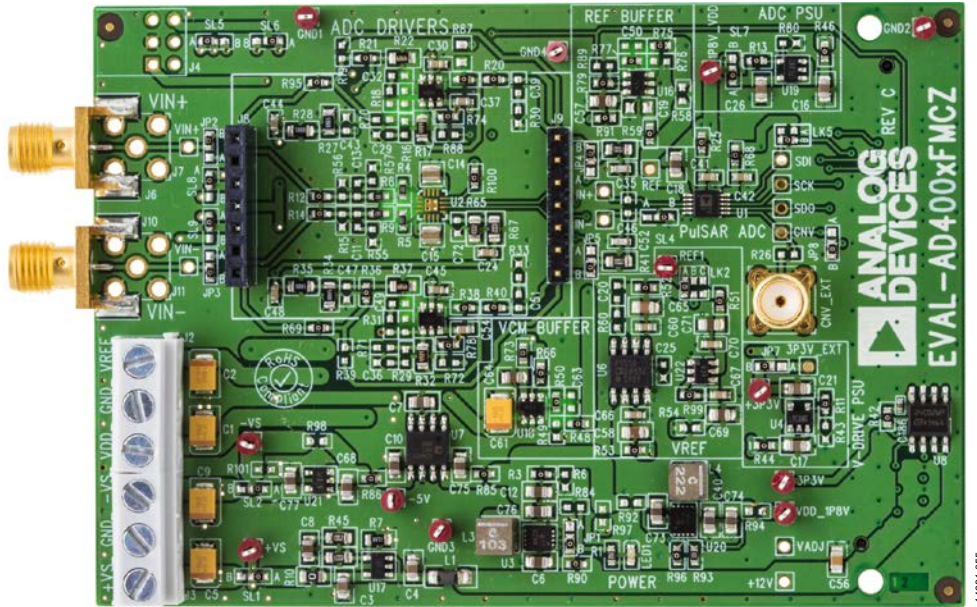

Figure 1. EVAL-AD400x-FMCZ

EVALUATION BOARD HARDWARE

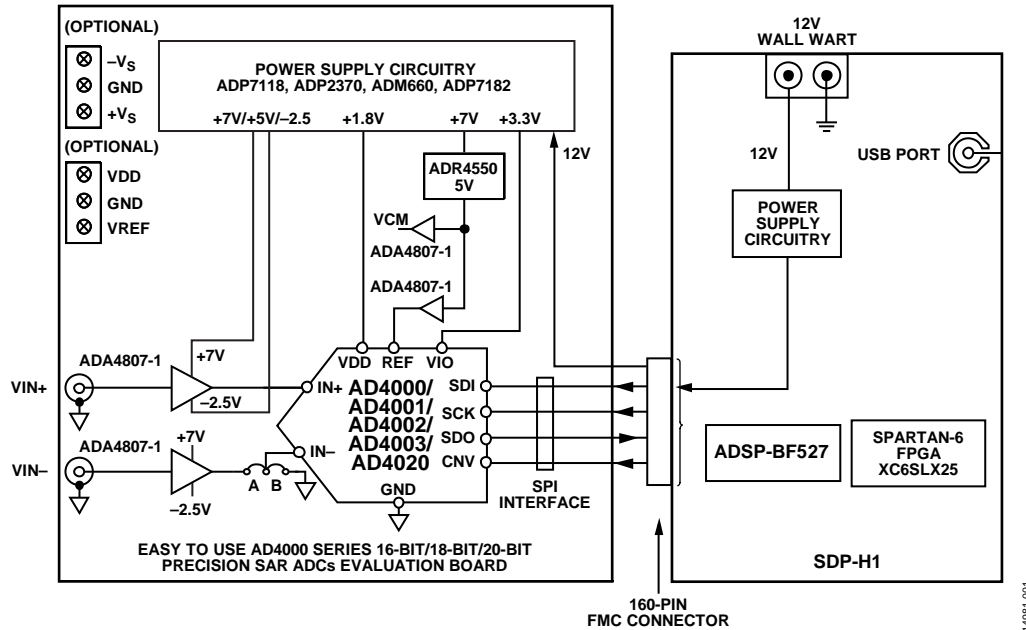

Figure 2. Simplified Evaluation Board Block Diagram

SETTING UP THE EVALUATION BOARD

Figure 2 shows the simplified evaluation board block diagram. Figure 24 shows the evaluation board schematic. The board consists of the ADC, U1, with a reference, U6 (ADR4550), and ADC drivers, U12 and U14, the ADA4807-1 for the AD4001/AD4002/AD4003/AD4020, and the ADA4805-1 for the AD4000 (see Table 6). The user also has an option to populate U2 with a low power, fully differential ADC driver, such as the ADA4940-1, when evaluating the AD4001/AD4003/AD4020. The evaluation board is a flexible design that enables the user to select components in addition to operating from an adjustable bench top power supply.

Identifying the Evaluation Board

A sticker label included on the bottom side (not pictured) of the EVAL-AD4000FMCZ/EVAL-AD4001FMCZ/EVAL-AD4002FMCZ/EVAL-AD4003FMCZ/EVAL-AD4020FMCZ indicates evaluation board options. For example, the EVAL-AD4020FMCZ evaluation board includes a sticker labeled EVAL-AD4020FMCZ.

POWER SUPPLIES

The system demonstration platform (SDP-H1) board supplies 12 V to power the necessary rails for the EVAL-AD400x-FMCZ evaluation boards.

The 7 V amplifier positive rail (+V_S) is generated from U17 (ADP7118). The -2.5 V negative amplifier rail (-V_S) is generated by a combination of U3 (ADP2370), U7 (ADM660), and U21 (ADP7182).

Each supply is decoupled where it enters the board and at each device. A single ground plane is used on this board to minimize the effect of high frequency noise interference.

In addition, the board can be powered from a benchtop power supply. The screw terminals, J2 and J3, are provided for this function. When bench power is used, the on-board power supplies are no longer required. The solder links also must be changed as follows: SL1 = SL2 = SL5 = SL6 = SL7 = SL8 = SL9 = B.

Table 1. Power Supplies Provided on the Board

Power Supply (V)	Function	Components Used
5, 7 (Default) ¹	Positive rail	ADP7118
-5, -2.5 (Default) ¹	Negative rail	ADP2370, ADM660, ADP7182
1.8	ADC power	ADP7118, ADP5300
3.3	V _{DRIVE} (digital power)	ADP7118

¹ See Table 2.

REFERENCE, REFERENCE BUFFER, AND COMMON-MODE BUFFER

An external 5 V reference (U6, ADR4550) is used by default to supply the ADCs directly. The user can also use one of the 2.5 V, 3.3 V, and 4.096 V references by changing the on-board reference device U6 (ADR4525/ADR4533/ADR4540). There is an option to use a lower power reference, U22 (ADR3450). Note that the ADR3450 cannot accept input voltages beyond 5.5 V. The ADA4807-1 is used as a reference buffer (U16) and common-mode buffer (U18) by default. However, U16 can also be replaced by the AD8031 if required without compromising the performance.

SDP-H1 CONTROLLER BOARD

The evaluation board uses a serial port interface (SPI) and is connected to the system demonstration platform (SDP-H1) controller board. The SDP-H1 board requires power from a 12 V wall adapter (included with the SDP-H1). The SDP-H1 has a Xilinx® Spartan 6 and an ADSP-BF527 processor with connectivity to the PC through a USB 2.0 high speed port. The SDP-H1 allows the configuration and capture of data on the evaluation boards from the PC via USB.

The SDP-H1 has an FMC LPC connector with full differential low voltage differential signaling (LVDS) and singled-ended low voltage complementary metal-oxide semiconductor (LVCMOS) support. The SDP-H1 also has a 120-pin connector that exposes the Blackfin® processor peripherals. This connector provides a configurable serial, parallel I²C and SPI, and general-purpose input/output (GPIO) communications lines to the attached daughter board.

SOLDER LINKS

The three solder link options on the evaluation board are configured depending on the generic of the ADC on the specific evaluation board, as described in Table 3.

The evaluation board supports any amplifier mezzanine card (AMC). Insert this add on card on the 7-pin headers. Figure 3 shows the AMC mounted on the evaluation board. The AMC ADC driver settings are required to use this option, described in Table 4.



Figure 3. AMC Installed on the EVAL-AD400x-FMCZ

14881-103

Table 2. Jumper Detail with Factory Default Setting

Link	Default Position	Function	Comments
SL1	A	+V _S	Change to Position B if using bench supplies
SL2	A	-V _S	Change to Position B if using bench supplies
SL5	A	+V _S	Change to Position B if using bench supplies
SL6	A	-V _S	Change to Position B if using bench supplies
SL7	A	VDD for ADC	Change to Position B if using bench supplies
LK2	A	VREF	Change to Position B if using the ADR3450
LK5 ¹	B	SDI	Change to Position A if using connecting SDI to the VIO voltage (V_DRIVE) ¹
JP1	B	FSEL (U3)	Change to Position A if selecting a 600 kHz switching frequency for the ADP2370 (U3)
JP2	B	ADC drivers	Change to Position A if using the ADA4940-1 fully differential ADC
JP3	B	ADC drivers	Change to Position A if using the ADA4940-1 fully differential ADC
JP4	B	ADC drivers	Change to Position A if using the ADA4940-1 fully differential ADC
JP5	B	ADC drivers	Change to Position A if using the ADA4940-1 fully differential ADC
JP7	B	V_DRIVE	Change to Position A if using external 3.3 V for V_DRIVE (VIO voltage)
JP8	B	Stop (U20)	Change to Position A if synchronizing ADP5300 (U20) STOP input with CNV_FMC from SDP-H1 connector

¹Setting LK5 to Position A prevents access to the configuration register of the connected device and does not allow features including turbo mode, high-Z mode, and so on, to be enabled.

Table 3. Jumpers Specific to 10-Lead Precision ADCs

Link	Default Position	Configuration	Generic
SL4	A	Differential input	AD4001 , AD4003 , AD4020
SL4	B	Single-ended or pseudo differential	AD4000 , AD4002

Table 4. EVAL-AD400x-FMCZ Configuration Settings for Amplifier Mezzanine Card ADC Driver

Component	Default Position/Values	Function	Comments
SL8	A	$-V_5$	Change to Position B if using bench supplies for AMC power
SL9	A	$+V_5$	Change to Position B if using bench supplies for AMC power
JP4, JP5	B	ADC driver outputs	Must be set to Position B to connect the ADC inputs to the AMC outputs
R20, R40	0 Ω	ADC driver outputs	Must not be installed in order to disconnect the on-board ADC driver outputs (U12 and U14)
R69, R95	0 Ω	ADC driver inputs	Must not be installed in order to disconnect the on-board ADC driver inputs (U12 and U14)
R28, R35	590 Ω	Provides dc common-mode voltage to ADC driver inputs	Must not be installed in order to disconnect the dc common-mode voltage from the on-board ADC driver inputs (U12 and U14)

ANALOG INPUTS

The analog inputs to the evaluation board are SMA connectors, J6 and J10. These inputs are buffered with dedicated amplifier circuitry (U12 and U14), as shown in Figure 26. The circuit allows different configurations, input range scaling, filtering, addition of a dc component, and use of different op amp and supplies. The analog input amplifiers are set as unity-gain buffers at the factory.

The optional fully differential amplifier (FDA) can be used with the fully differential **AD4000** devices on the **EVAL-AD4001FMCZ**, **EVAL-AD4003FMCZ**, and **EVAL-AD4020FMCZ** boards. Table 2 lists the necessary jumper positions for using the FDA (U2).

The **AD4000** family devices require the inputs to be biased at midscale. The default configuration also sets both U12 and U14 at midscale, generated from a buffered reference voltage divider (VCM). The noninverting inputs of both U12 and U14 are connected to the 590 Ω resistor dividers by default. These resistor

dividers, R27, R28, R34, and R35, divide the reference voltage in half. The 590 Ω resistor dividers must be taken into account when interfacing with an external source via J6 and J10. The FDA (U2) outputs are biased to midscale with a 10 k Ω resistor divider (R65 and R67).

The **EVAL-AD400x-FMCZ** evaluation boards are factory configured to provide the appropriate input signal type, single-ended or fully differential, with the SL4 link. See Table 2 and Figure 26 for more information.

To evaluate dynamic performance, a fast Fourier transform (FFT) test can be performed by applying a very low distortion ac source.

For low frequency testing, the audio precision source (such as the SYS-2700 series) can be used directly because the outputs on these are isolated. Set the outputs for balanced and floating ground. Different precision sources can be used with additional filtering.

GETTING STARTED

The [EVAL-AD400x-FMCZ](#) evaluation boards can be controlled with the [AD40XX Evaluation Software Installer](#). The following sections provide instructions for installing the supporting software and an overview for connecting the hardware to the PC.

SOFTWARE INSTALLATION PROCEDURES

The [AD40XX Evaluation Software Installer](#) installs the [AD40XX Evaluation Software Installer](#) and accompanying drivers for the [SDP-H1](#) board. Install this software installer package before connecting the [SDP-H1](#) board to the PC USB port to ensure that the [SDP-H1](#) board is recognized when it connects to the PC.

Installing the [AD40XX Evaluation Software Installer](#)

To install the [AD40XX Evaluation Software Installer](#), adhere to the following steps:

1. Start the Windows® operating system and download the software from the [EVAL-AD400x-FMCZ](#) product page.
2. Unzip the downloaded file. Run the **setup.exe** file.
3. Begin installing the evaluation software by clicking the **setup.exe** file. The software installation window opens as shown in Figure 4.

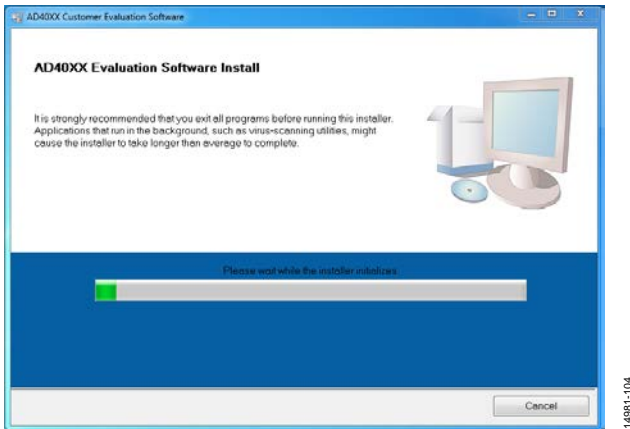

Figure 4. **AD40XX Evaluation Software Install Window**

4. Choose the installation directory and click **Next**. The default location is **C:\Program Files (x86)\Analog Devices**.

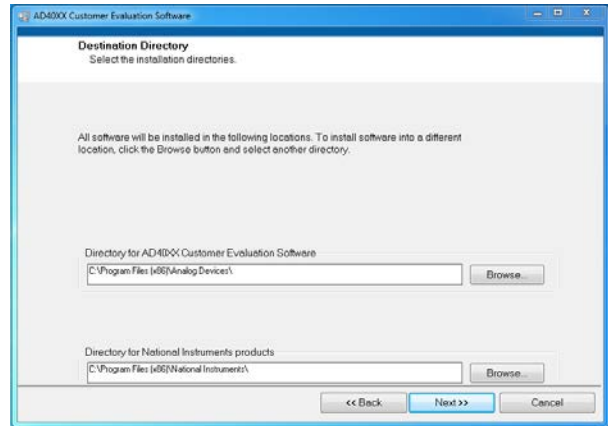

Figure 5. **Destination Directory Window**

5. Installing the [AD40XX Evaluation Software Installer](#) requires users to accept the license agreement shown in Figure 6. Read the agreement before clicking **Next** to proceed.



Figure 6. **License Agreement Window**

- The window shown in Figure 7 provides a summary of the software installation. Click **Next** to install the software listed in the window.

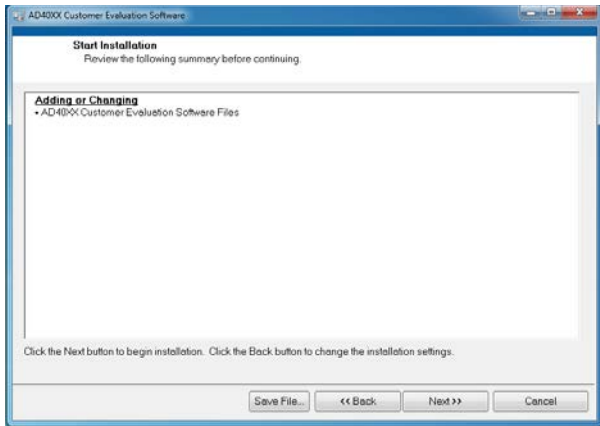

Figure 7. Start Installation Window

- A pop-up window opens and displays a bar showing the installation progress, as shown in Figure 8.

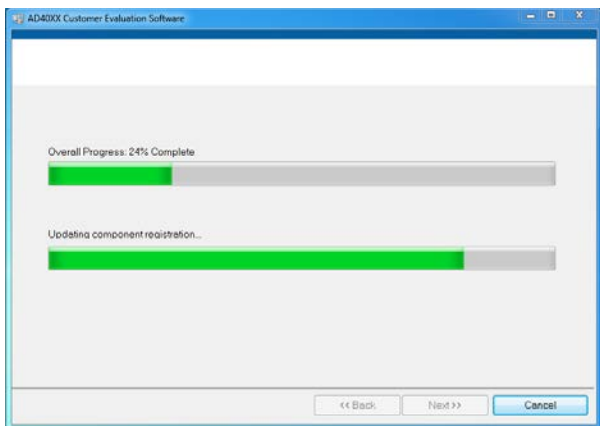

Figure 8. Overall Progress

- Click **Next** to complete the installation and launch the **SDP-H1** driver installation, as shown in Figure 9.

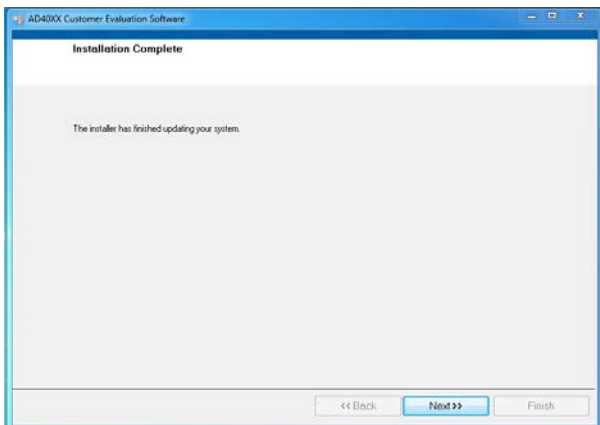

Figure 9. Installation Complete Window

Installing the **SDP-H1** Board Drivers

The **AD40XX Evaluation Software Installer** uses the ADI SDP drivers (Version 2.3.0.207) to interface with the **SDP-H1** controller board. Following the successful software installation, the installer automatically begins installing the ADI SDP drivers (indicated by the pop-up shown in Figure 10).

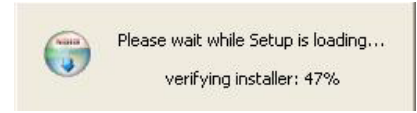

Figure 10. **SDP-H1** Driver Installation

- The **ADI SDP Drivers 2.3.0.207 Setup** wizard opens the window, as shown in Figure 11. Click **Next** to install the **SDP-H1** drivers.



Figure 11. **ADI SDP Drivers 2.3.0.207 Setup** Window

- Installing the **ADI SDP Drivers 2.3.0.207** requires the user to accept the license agreement that appears in Figure 12. Read the agreement before clicking **I Agree** to proceed.

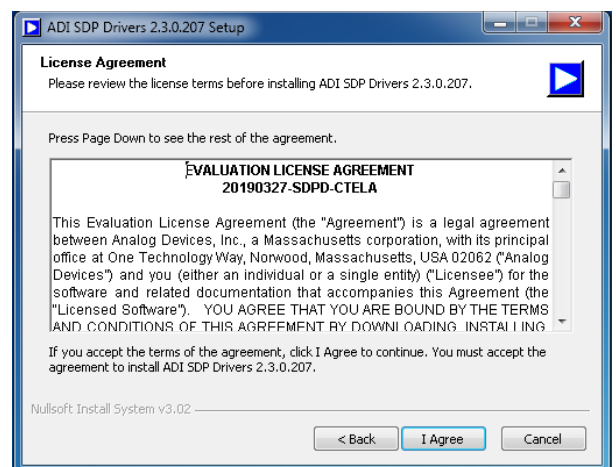

Figure 12. **ADI SDP Drivers (v2.3.0.207) License Agreement** Window

- Choose the destination folder for the ADI SDP drivers and click **Install**. The default folder is shown in Figure 13.

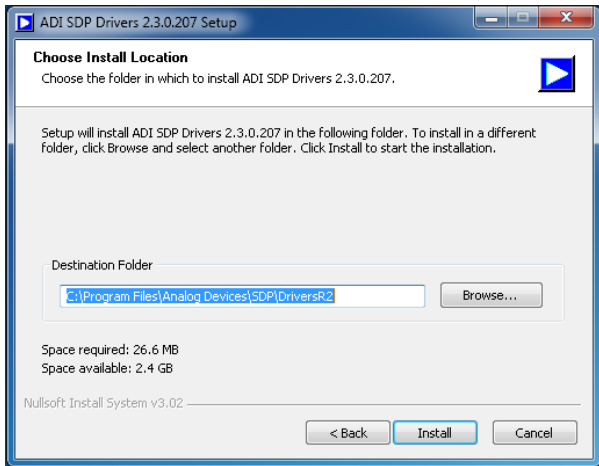

Figure 13. Choose Install Location

- Click the **Close** button shown in Figure 15 when the installation is complete.

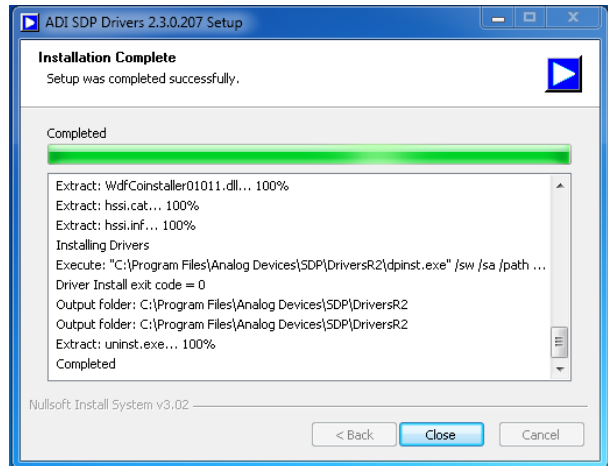

Figure 15. Installation Complete

- The installation begins, and a progress bar shown in Figure 14 is displayed.

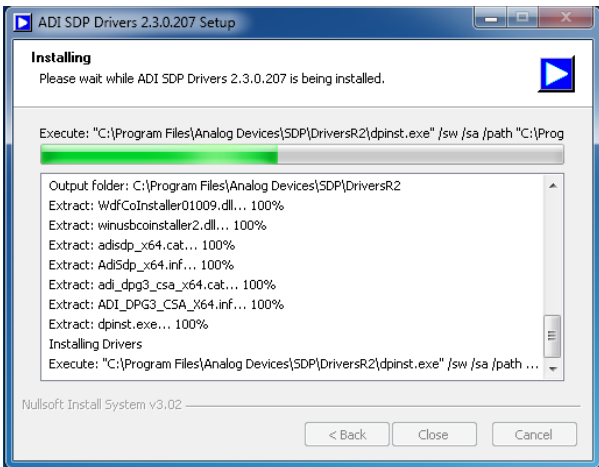

Figure 14. Installing

When plugging in the **SDP-H1** board via the provided USB cable, allow the **Found New Hardware Wizard** to run. Check that the drivers are installed and the **SDP-H1** board are connected properly by checking the **Device Manager** of the PC. If the drivers and board are connected, **Analog Devices System Development Platform (32MB)** appears under **ADI Development Tools** (see Figure 16).

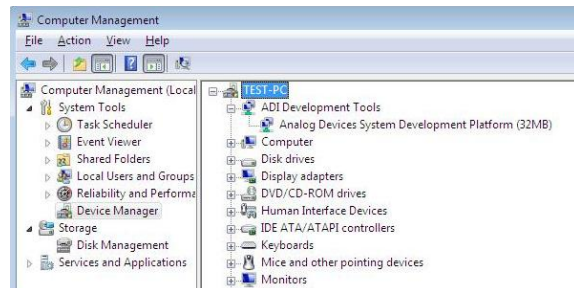

Figure 16. Device Manager Menu

Uninstalling the Software

To uninstall the [AD40XX Evaluation Software Installer](#), take the following steps:

1. Launch the uninstall wizard by navigating to **Start > Control Panel > Programs and Features > AD40XX Customer Evaluation Software** to open a window with the **Uninstall** button.
2. Click **Yes** in the confirmation window that appears.

To uninstall the SDP drivers, adhere to the following steps:

1. Launch the uninstall wizard by navigating to **Start > Control Panel > Programs and Features > ADI SDP Drivers 2.3.0.207** to open a window with the **Uninstall** button.
2. Click **Yes** in the confirmation window that appears.

EVALUATION HARDWARE SETUP PROCEDURES

The [EVAL-AD400x-FMCZ](#) evaluation boards connect to the [SDP-H1](#) via the FMC connector (J5). The [SDP-H1](#) is the controller board and functions as the communication link between the PC and connected [EVAL-AD400x-FMCZ](#) evaluation board.

Connecting the Evaluation Hardware to a PC

To connect the [EVAL-AD400x-FMCZ](#) evaluation board and [SDP-H1](#) board to a PC:

1. Before connecting power, connect the FMC connector of the [EVAL-AD400x-FMCZ](#) evaluation board (J5) to the FMC connector on the [SDP-H1](#) board (J4).
2. Power the [SDP-H1](#) with the appropriate supply, as described in the Power Supplies section.
3. Connect the [SDP-H1](#) to the PC with the USB cable.

Verifying Hardware Connection

To verify the [AD4000](#) family evaluation board is properly connected to the PC, take the following steps:

1. Allow the **Found New Hardware Wizard** to finish running after the [SDP-H1](#) board is connected to the PC via the USB cable. Choose the **automatically search for the appropriate drivers** option for the SDP drivers if prompted.
2. Verify the hardware to PC connection by navigating to the **Device Manager** via the **Control Panel**. If the hardware is properly connected, **Analog Devices SDP-H1** appears under **ADI Development Tools**.

SOFTWARE OPERATION

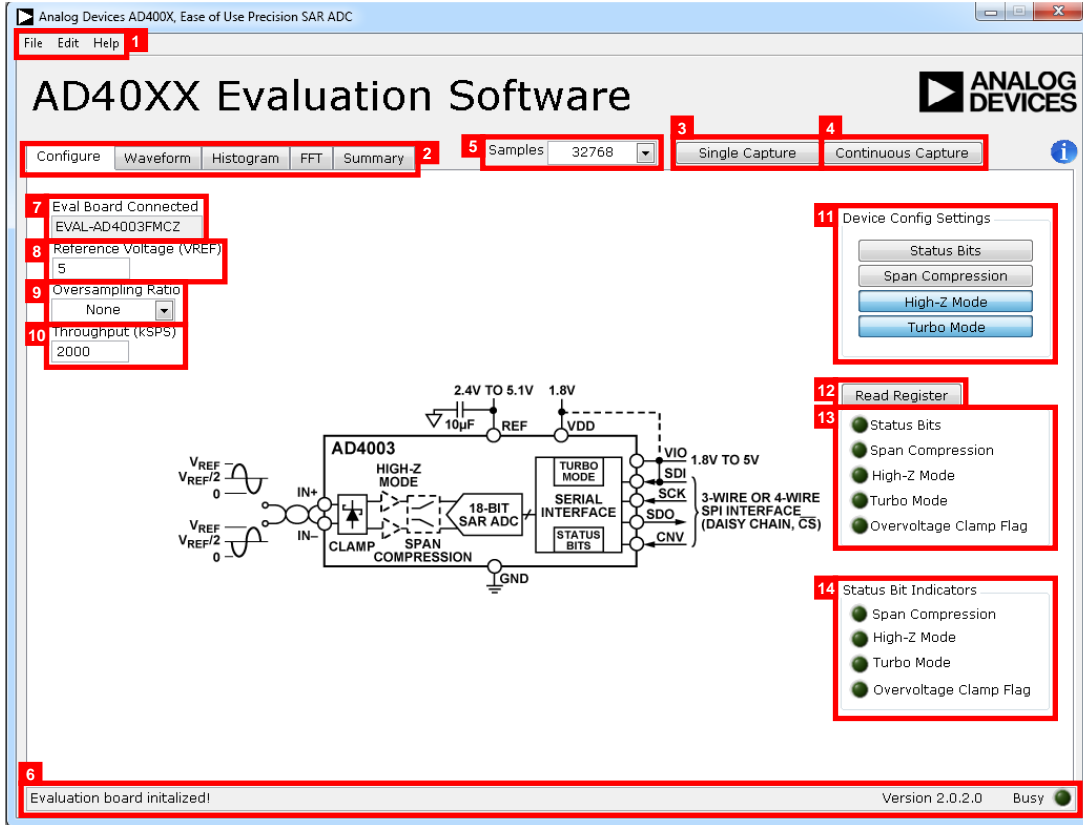

Figure 17. AD40XX Evaluation Software Front Panel (Configure Tab View)

RUNNING THE EVALUATION SOFTWARE

After installing the [AD40XX Evaluation Software Installer](#) (see the Software Installation Procedures section), run the software with either of the following methods:

- Navigate to the destination folder of the [AD40XX Evaluation Software Installer](#) selected during the installation procedure and run the EVAL-AD40xx.exe file.
- Click **Start > All Programs > Analog Devices > AD40XX Evaluation Software > AD40xx Evaluation Software**.

ESTABLISHING HARDWARE CONNECTION

After the [AD40XX Evaluation Software Installer](#) initializes, the software front panel appears, and the software automatically connects to any EVAL-AD400x-FMCZ evaluation board connected to the PC. The detected evaluation board is displayed in the **Eval Board Connected** indicator on the front panel (see Label 7 in Figure 17).

If the software does not detect a valid EVAL-AD400x-FMCZ evaluation board, a connectivity error dialog box appears (see Figure 18). Clicking the **Rescan** button instructs the software to try to detect the hardware again. Clicking the **Offline Mode** button causes the software to boot in offline mode. See the Saving and Loading Sessions section for the functions provided in offline mode.

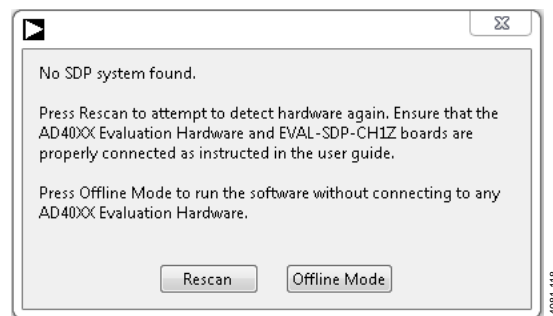

Figure 18. Connectivity Error Dialog Box

OVERVIEW OF THE FRONT PANEL

The [AD40XX Evaluation Software Installer](#) front panel is shown in Figure 17. The following sections describe the various software controls accessible on the front panel.

File Menu

The **File** menu (Label 1 in Figure 17) provides the following options:

- **Save Captured Data (Ctrl + S):** saves the current [AD40XX Evaluation Software Installer](#) session in a .csv file. The user is prompted to either choose or enter the path of the file in the **Save As** dialog box. This saved file can be loaded by the software at a future time to display previously captured data.

- **Load Captured Data (Ctrl + O):** opens the **Load File** dialog box and the user is prompted to load the previously saved evaluation software session files (.csv).
- **Take Screenshot:** saves the current front panel display as an image file (.jpg). The user is prompted to either choose or enter the path of the file in a **Save As** dialog box.
- **Print Screenshot:** sends a screenshot of the current front panel display directly to the default printer identified by the operating system for printing.
- **Exit:** closes the **AD40XX Evaluation Software Installer** front panel and exits the software.

Edit Menu

The **Edit** (Label 1 in Figure 17) menu provides the following option:

- **Reinitialize Default Values:** resets a subset of the **AD40XX Evaluation Software Installer** front panel controls to the default state.

Help Menu

The **Help** menu (Label 1 in Figure 17) provides the following options:

- **Analog Devices Website:** opens the Analog Devices webpage (www.analog.com) in the default browser of the PC.
- **AD4000 Evaluation Hardware Info:** opens the **AD4000** family evaluation board **EVAL-AD400x-FMCZ** product page in the default browser of the PC.
- **Context Help (Ctrl + H):** displays a context help dialog box, which displays information about the various software controls when the mouse hovers over them.
- **About (Ctrl + A):** displays version and copyright information of the **AD40XX Evaluation Software Installer** in a dialog box.

Display Tabs

The following five tabs are located at the top of the front panel (Label 2 in Figure 17): **Configure**, **Waveform**, **Histogram**, **FFT**, and **Summary**. These tabs select various front panel views.

Single Capture Button

Click **Single Capture** (Label 3 in Figure 17) to perform a single set of conversions. The number of conversions performed is set with the **Samples** dropdown list, which is located to the left of the **Single Capture** control.

Continuous Capture Button

Click **Continuous Capture** (Label 4 in Figure 17) to perform repeated sets of conversions. The number of conversions performed per set is set with the **Samples** dropdown list.

Samples Dropdown List

The **Samples** dropdown list (Label 5 in Figure 17) sets the number of conversions that are performed when **Single Capture** is clicked. The button also sets the number of conversions per set when **Continuous Capture** is clicked.

Status Bar

The status bar (Label 6 in Figure 17) displays information about the current process being completed by the **AD40XX Evaluation Software Installer**. The **Status Bar** includes a **Busy** indicator, which displays if the software is busy performing a task such as performing conversions, analyzing results, and so on.

CONFIGURE TAB

Figure 17 shows the **Configure** tab view. The **Configure** tab provides controls for configuring the connected **AD4000** family device and software settings. The **Configure** tab view contains the following controls and indicators:

- **Eval Board Connected** (Label 7 in Figure 17): indicates that the **EVAL-AD400x-FMCZ** board is connected to the software.
- **Reference Voltage (VREF)** (Label 8 in Figure 17): sets the VREF used in data analysis such as when calculating **LSB Size** (see Label 2 in Figure 19), or measured voltage in the waveform graph (see the **Waveform Tab View** section. This control must be set to match the VREF used on the connected **AD4000** family evaluation board.
- **Oversampling Ratio** (Label 9 in Figure 17): sets the oversampling ratio applied to the captured data. After this control is set to any value other than **None**, the software sums up the consecutive conversion results together to increase effective resolution. The number of conversions summed together is set by the **Oversampling Ratio** control.
- **Throughput (kSPS)** (Label 10 in Figure 17): sets the throughput of the connected **AD4000** family device. The maximum value of this control is automatically set to reflect the maximum achievable throughput of the connected device, given the state of the **Status Bits** and **Turbo Mode** controls. See the relevant **AD4000** family device data sheet for more information on maximum achievable throughput.
- **Device Config Settings** (Label 11 in Figure 17): configures the connected **AD4000** family device user configuration register settings. See the relevant **AD4000** family device data sheet for a detailed description of the user configuration register and the device features.
 - **Status Bits:** enables or disables the status bits for the connected device.
 - **Span Compression:** enables or disables span compression for the connected device.
 - **High-Z Mode:** enables or disables high-Z mode.
 - **Turbo Mode:** enables or disables turbo mode for the connected device.
- **Read Register** (Label 12 in Figure 17): reads the **AD4000** family device user register. When **Read Register** is clicked, the contents of the connected **AD4000** family device register are read to update the **Device Config Settings** items accordingly.
- **Device configuration settings display** (Label 13 in Figure 17): displays the status of the user register when **Read Register** is clicked. Each of the following indicators displays the state of the corresponding settings:

- **Status Bits, Span Compression, High-Z Mode, and Turbo Mode** status indicators indicate whether the corresponding AD4000 family device are reported as enabled or disabled in the user configuration register of the connected AD4000 family device.
- **Overvoltage Clamp Flag:** indicates the status of the \overline{OV} clamp flag in the user configuration register of the connected device. When this indicator is red, the \overline{OV} flag is low, indicating the presence of an overvoltage event.
- **Status Bits Indicators** (Label 14 in Figure 17): displays the configuration settings of the device as indicated by the status bits. The status bits are enabled with the **Status Bits** control in the **Device Config Settings** pane (Label 11 in Figure 17). The **Status Bits Indicators** are only updated after conversions are performed with the **Single Capture** or **Continuous Capture** controls when the status bits are enabled on the connected AD4000 family device. The

status bit functionality is described in the relevant AD4000 family device data sheet.

- The **Span Compression, High-Z Mode, and Turbo Mode** status indicators indicate whether features of the corresponding AD4000 family device is reported as enabled or disabled by the status bits of the connected AD4000 family device.
- **Overvoltage Clamp Flag:** displays whether the \overline{OV} clamp flag in the status bits indicated an overvoltage event in any of the conversions in the most recently displayed results. When this indicator is red, the \overline{OV} flag is low, indicating the presence of an overvoltage event. See the AD4000 family data sheets for more details on the \overline{OV} clamp flag.

WAVEFORM TAB VIEW

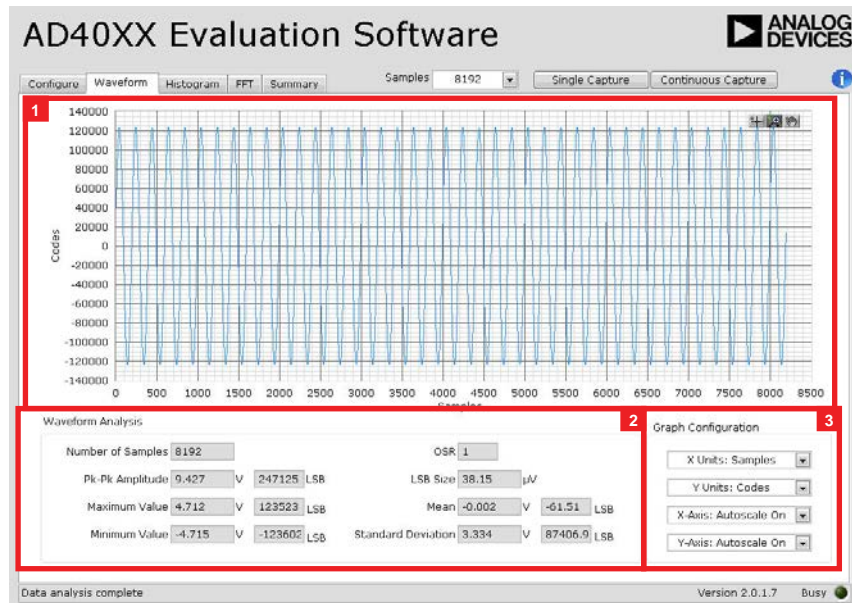

Figure 19. Waveform Tab View

Figure 19 shows the **Waveform** tab view. The **Waveform** tab view shows the time domain representation of the conversion results from the connected **AD4000** family device, as well as several analysis items. The **Waveform** tab view contains the following controls and indicators:

- **Waveform graph** (Label 1 in Figure 19): displays the time domain plot of the most recently captured or loaded conversion results. The scale and range of the waveform graph can be set in the **Waveform Analysis** box by double clicking on the **Minimum Value** and **Maximum Value** fields and entering the desired values. The waveform graph also includes viewing tools that are described in Table 5.
- **Waveform Analysis** (Label 2 in Figure 19): shows the following analysis items for the currently displayed data.
 - **Number of Samples**: displays the number of captured samples in the data displayed in the waveform graph. The displayed value factors in the oversampling ratio that is set with the **OSR** control.
 - **Pk-Pk Amplitude**: displays the peak-to-peak amplitude of the captured data (the difference between the **Maximum Value** and the **Minimum Value**).
 - **Maximum Value**: displays the maximum value measured in the captured data.
 - **Minimum Value**: displays the minimum value measured in the captured data.
 - **OSR**: displays the oversampling ratio applied to the captured data. The **OSR** can be changed using the **Oversampling Ratio** control in the **Configure** tab view.
 - **LSB Size**: displays the effective size (in μV) of each LSB given the resolution of the connected **AD4000** family device, the **Reference Voltage (VREF)**, and the **Oversampling Ratio** values selected in the **Configure** tab view.
 - **Mean**: displays the arithmetic mean of the captured data.
 - **Standard Deviation**: displays the standard deviation of the captured data.
- **Graph Configuration** pane (Label 3 in Figure 19): sets the following waveform graph axis properties.
 - **X units**: sets the x-axis units of the waveform graph. The x-axis units can be either set to samples or seconds. The time step size, when **Seconds** is selected, is calculated from the selected **Throughput** and **Oversampling Ratio** controls in the **Configure** tab view.
 - **Y units**: sets the y-axis units of the waveform graph. The y-axis units can be either set to codes or volts. The voltage values, displayed when **Volts** is selected, is calculated from the **LSB Size** in the **Waveform Analysis** items.
 - **X-axis: autoscale**: sets whether the x-axis range of the waveform graph autoscales as new data is plotted or remains at a fixed scale.
 - **Y-axis: autoscale**: sets whether the y-axis range of the waveform graph autoscales or remains at a fixed scale as new data is plotted.

HISTOGRAM TAB VIEW

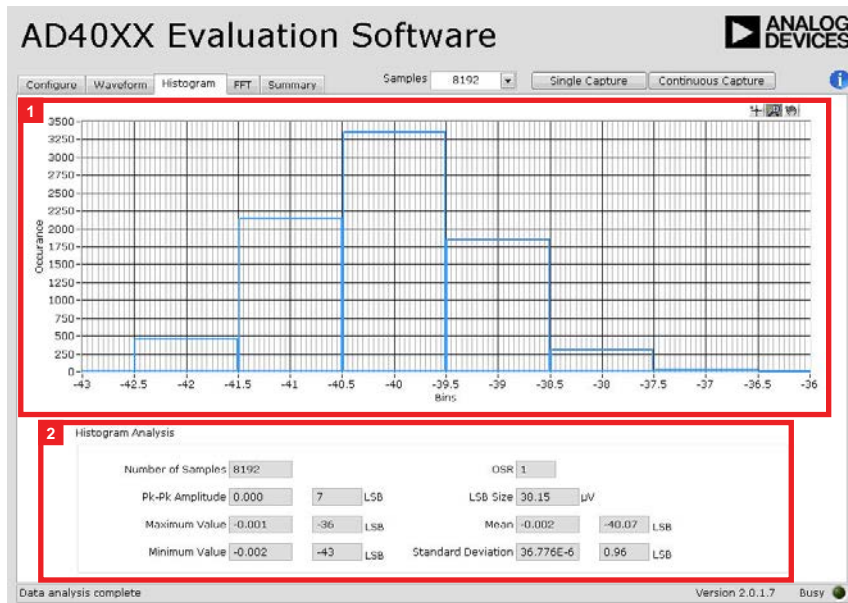

Figure 20. Histogram Tab View

Figure 20 shows the **Histogram** tab view. The **Histogram** tab is useful for performing statistical analysis of the **AD4000** family device conversion results, especially when measuring dc signals. The histogram graph shows the distribution of the conversion results as well as various statistical analysis items. The **Histogram** tab contains the following controls and indicators:

- **Histogram graph** (Label 1 in Figure 20): displays histogram of the most recently captured or loaded conversion results. The scale and range of the histogram graph can be set by double-clicking on the minimum and maximum axis values and entering the desired values. The histogram graph also includes viewing tools, described in Table 5.
- **Histogram Analysis** (Label 2 in Figure 20): shows the following analysis items for the currently displayed data.
 - **Number of Samples**: displays the number of captured samples in the data displayed in the histogram graph. The displayed value factors in the oversampling ratio shown in the **OSR** indicator.
 - **Pk-Pk Amplitude**: displays the peak-to-peak amplitude of the captured data (the difference between the **Maximum Value** and the **Minimum Value**).
 - **Maximum Value**: displays the maximum value measured in the captured data.
 - **Minimum Value**: displays the minimum value measured in the captured data.
 - **OSR**: displays the oversampling ratio applied to the captured data. The **OSR** can be changed using the **Oversampling Ratio** control in the **Configure** tab view.
 - **LSB Size**: displays the effective size (in μV) of each LSB given the resolution of the connected **AD4000** family device, and the **Reference Voltage (VREF)** and **Oversampling Ratio** values selected in the **Configure** tab.
 - **Mean**: displays the arithmetic mean of the captured data.
 - **Standard Deviation**: displays the standard deviation of the captured data.

FFT TAB VIEW

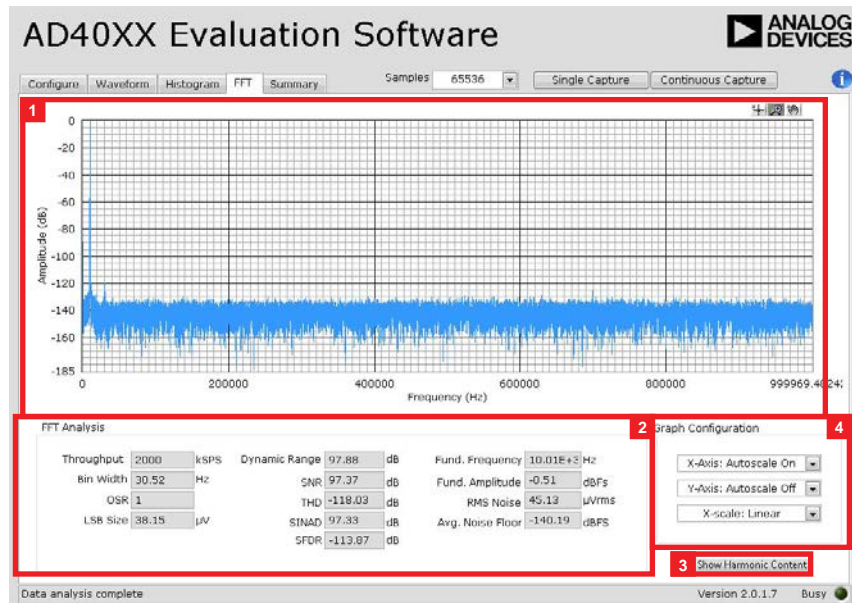

Figure 21. FFT Tab View

Figure 21 shows the FFT tab view. The FFT tab displays the calculated FFT representation of the conversions results from the connected **AD4000** family device and common ac performance metrics. The FFT tab contains the following controls and indicators:

- **FFT graph** (Label 1 in Figure 21): displays an FFT of the most recently captured or loaded conversion results. Set the scale and range of the FFT graph by double clicking on the minimum and maximum values along the x-axis and y-axis and entering the desired values. The FFT graph also includes viewing tools that described in Table 5.
- **FFT Analysis** (Label 2 in Figure 21): displays common ac performance metrics of the captured data. Results are calculated from the FFT spectrum, typically ignoring the first six frequency bins.
 - **Throughput**: displays the effective throughput (sample rate) of the captured data. The displayed value factors in the oversampling ratio displayed in the **OSR** indicator.
 - **Bin Width**: displays the size of the frequency bins in the FFT graph x-axis. The bin width is a function of both the **Throughput (kSPS)** control (Label 10 in Figure 17) and the number of samples in the captured data.
 - **OSR**: displays the oversampling ratio applied to the captured data. The **OSR** can be changed using the **Oversampling Ratio** control in the **Configure** tab.
 - **LSB Size**: displays the effective size (in μV) of each LSB. The LSB size is a function of the resolution of the connected **AD4000** family device, the **Reference Voltage (VREF)**, and the **Oversampling Ratio** values selected in the **Configure** tab view.
 - **Dynamic Range**: displays the calculated dynamic range.
 - **SNR**: displays the calculated signal-to-noise ratio (SNR).
 - **THD**: displays calculated total harmonic distortion (THD), up to the fifth harmonic.
 - **SINAD**: displays the calculated single-to-noise and distortion ratio (SINAD).
 - **SFDR**: displays the calculated spurious-free dynamic range (SFDR).
 - **Fund. Frequency**: displays the frequency identified as fundamental, the frequency bin with the largest signal.
 - **Fund. Amplitude**: displays amplitude of the fundamental frequency, the frequency bin with the largest signal.
 - **RMS Noise**: displays the measured rms voltage noise.
 - **Avg. Noise Floor**: displays the average amplitude of noise frequency bins, more specifically, bins not identified as fundamental or harmonic.
- **Show Harmonic Content**: contains **Frequency** and **Amplitude** information for the fundamental and harmonic tones identified in the FFT. These displays are only visible when toggled by the **Show Harmonic Content** control and are not displayed in Figure 21.
 - **Frequency**: frequency bins identified as fundamental and harmonic.
 - **Amplitude**: amplitude of the fundamental and harmonic frequencies.
- **Graph Configuration**: sets the following FFT graph axis properties.
 - **X-axis: autoscale**: sets whether the FFT graph x-axis range autoscales as new data is plotted or remains at a fixed scale.
 - **Y-axis: autoscale**: sets whether the FFT graph y-axis range autoscales as new data is plotted or remains at a fixed scale.
 - **X-axis scale**: sets whether the FFT graph x-axis scaling is linear or logarithmic.

SUMMARY TAB VIEW

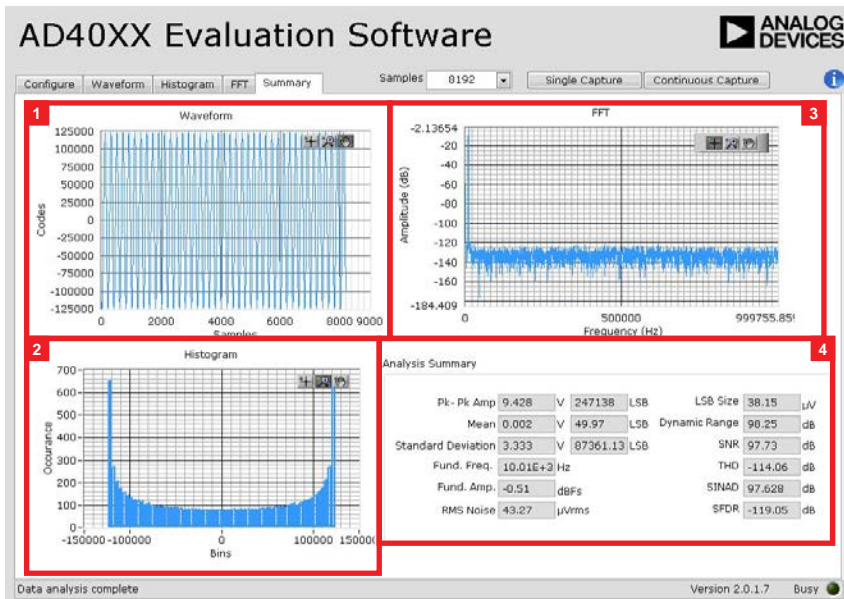

Figure 22. AD40XX Evaluation Software **Summary** Tab View



Figure 22 shows the **Summary** tab view. The **Summary** tab simultaneously displays the waveform, histogram, and FFT graphs and analysis for the AD4000 family device conversion results on the screen. The **Summary** tab contains the following controls and indicators:

- **Waveform graph** (Label 1 in Figure 22): displays the time domain plot of the most recently captured or loaded conversion results. The scale and range of the waveform graph can be set by double-clicking on the minimum and maximum axis values along the x-axis and y-axis and entering the desired values. The waveform graph also includes viewing tools that are described in Table 5.
- **Histogram graph** (Label 2 in Figure 22): displays the histogram of the most recently captured or loaded conversion results. The scale and range of the histogram graph can be set by double-clicking on the minimum and maximum values along the x-axis and y-axis and entering the desired values. The histogram graph also includes viewing tools that are described in Table 5.
- **FFT graph** (Label 3 in Figure 22): displays an FFT of the most recently captured or loaded conversion results. The scale and range of the FFT graph can be set by double-clicking on the minimum and maximum axis values and entering the desired values. The FFT graph also includes viewing tools that are described in Table 5.
- **Analysis Summary** (Label 4 in Figure 22): shows the following analysis items for the currently displayed data.
 - **Pk-Pk Amp:** displays the peak-to-peak amplitude of the captured data.
 - **Mean:** displays the arithmetic mean of the captured data.
 - **Standard Deviation:** displays the standard deviation of the captured data.
 - **Fund. Freq.:** displays frequency identified as the fundamental (the frequency bin with the largest signal).
 - **Fund. Amp.:** displays the amplitude of the **Fund. Freq.**
 - **RMS Noise:** displays the measured rms voltage noise of the captured data.
 - **LSB Size:** displays the effective size (in μV) of each LSB. The LSB size is a function of the resolution of the connected AD4000 family device, the **Reference Voltage (VREF)**, and **Oversampling Ratio** values selected in the **Configure** tab.
 - **Dynamic Range:** displays the calculated dynamic range of the captured data.
 - **SNR:** displays the calculated SNR of the captured data.
 - **THD:** displays the calculated THD of the captured data (up to the fifth harmonic).
 - **SINAD:** displays the calculated SINAD of the captured data.
 - **SFDR:** displays the calculated SFDR of the captured data.

GRAPH VIEWING CONTROLS

The tools described in Table 5 allow users to control the different chart displays within any of the chart panels in the graphical user interface (GUI) tabs.

Table 5. GUI Tools

Symbol	Description
	This tool controls the cursor, if present.
	This tool zooms in and out of the data on the graph.
	This tool is used for panning.

SAVING AND LOADING SESSIONS

The [AD40XX Evaluation Software Installer](#) allow users to save and load data to quickly recall previous results.

Clicking **File > Save Captured Data** or using the shortcut **Ctrl + S** saves the capture data and relevant sampling parameters for the currently displayed [AD4000](#) family device in a .csv file. These saved files can be loaded at a later time by clicking **File > Load Captured Data** or using the shortcut **Ctrl + O**. Upon loading these .csv files, the evaluation software displays the data in the **Waveform**, **Histogram**, **FFT**, and **Summary** tabs.

The evaluation software also allows the user to export the raw data of any of the graphs into a generic text file by right clicking them and selecting **Export > Export Data to Excel**, as shown in Figure 23. The exported data can be used for additional postprocessing, but the generated text file cannot be loaded back into the [AD40XX Evaluation Software Installer](#).

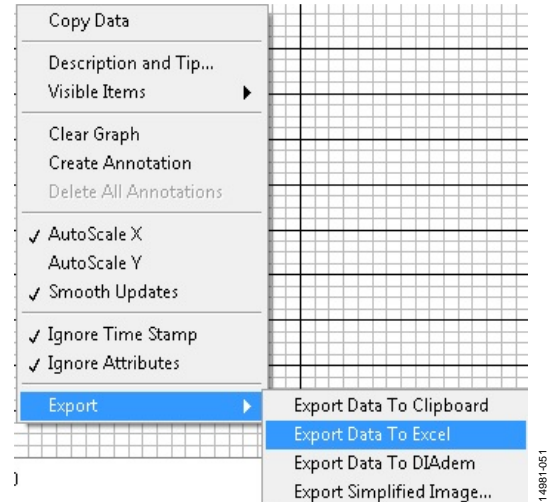

Figure 23. Export Raw Data

OFFLINE MODE

The [AD40XX Evaluation Software Installer](#) can be operated without an accompanying [EVAL-AD400x-FMCZ](#) evaluation board. If no [EVAL-AD400x-FMCZ](#) evaluation board is detected when the software initializes, the dialog box in Figure 18 is displayed. Clicking **Offline Mode** causes the evaluation software to boot in offline mode.

In offline mode, new conversion results cannot be captured, but previously saved [AD40XX Evaluation Software Installer](#) sessions can be loaded to view previously captured data. See the Saving and Loading Sessions section for instructions on loading previously saved data.

TROUBLESHOOTING

SOFTWARE

To troubleshoot the software, take the following steps:

1. Always install the software before connecting the hardware to the PC.
2. Always allow the install to fully complete (the software is a two-part installation, the ADC evaluation software and the [SDP-H1](#) drivers). A restart is recommended after installation is finished.
3. When the user first plugs in the [SDP-H1](#) board via the provided USB cable, allow the **Found New Hardware Wizard** to run, which can take several seconds. However, allow this to happen before starting the software.
4. If the [EVAL-AD400x-FMCZ](#) evaluation boards or [SDP-H1](#) board are connected to the PC via the USB port but are not being detected by the [AD40XX Evaluation Software Installer](#), ensure that the board is being recognized in the **Device Manager**, as shown in Figure 16.
5. If connected to a slower USB port where the [SDP-H1](#) cannot read as quickly as it needs to, a timeout error can result. In this case, it is advised not to read continuously, or alternatively, to lower the number of samples taken.

HARDWARE

To troubleshoot the hardware, take the following steps:

1. If the software does not read back any data, do the following:
 - a. Check that the power is applied within the power ranges described in the Power Supplies section.
 - b. Using a voltmeter, measure the voltage present at each of the test points: +V_s, -V_s, 1P8V_VDD, VDD_1P8V, +3P3V, +5V, and REF1, and common-mode voltages (REF/2) at IN+ and IN- to ensure that they are accurate. The [SDP-H1](#) board LED1 must be illuminated.
 - c. Launch the software and read the data. If nothing happens, exit the software.
 - d. Power down the board and relaunch the software.
 - e. If no data is read back, confirm that the ADC evaluation board is connected to the [SDP-H1](#) board and that the board is being recognized in the **Device Manager**, as shown in Figure 16.
2. When the user is working with the software in standalone/offline mode (no hardware connected) and later chooses to connect hardware, close and relaunch the software.

EVALUATION BOARD SCHEMATICS AND ARTWORK

Power supply for Amplifiers

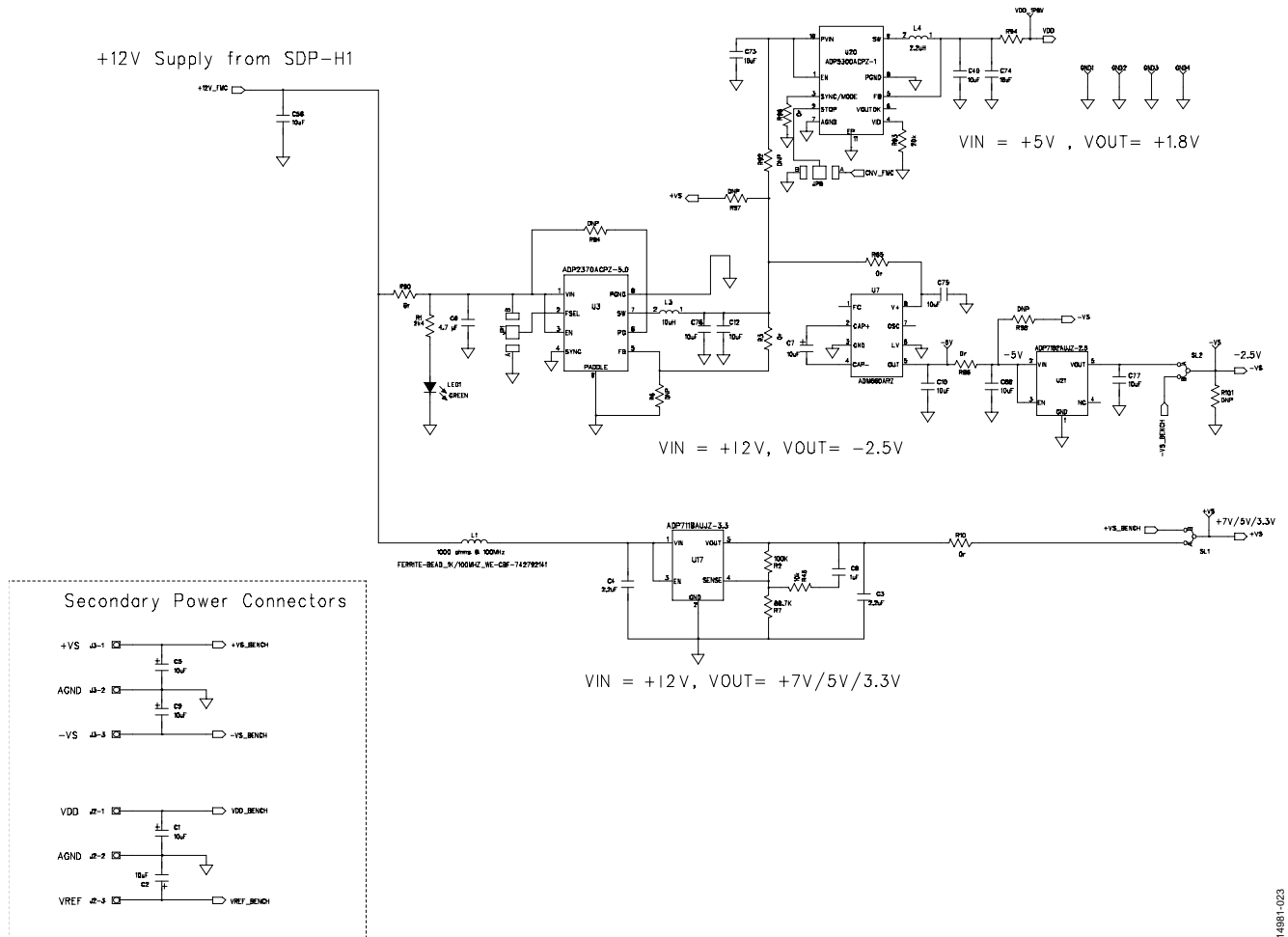
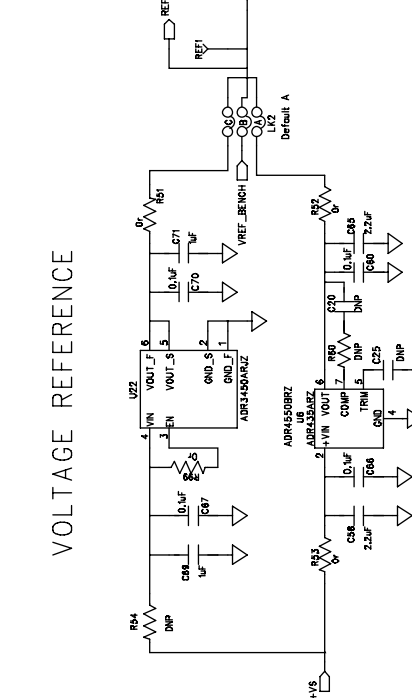
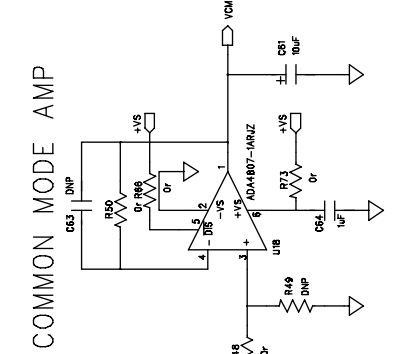
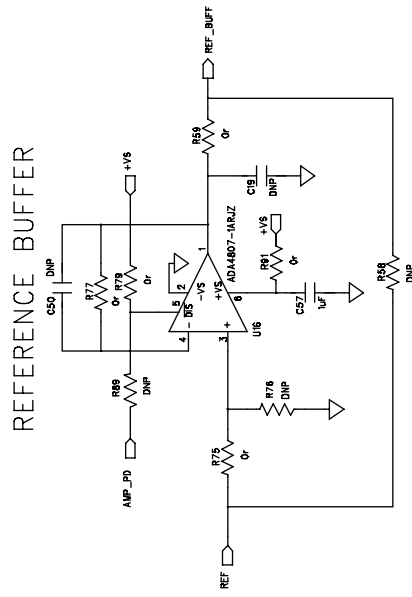
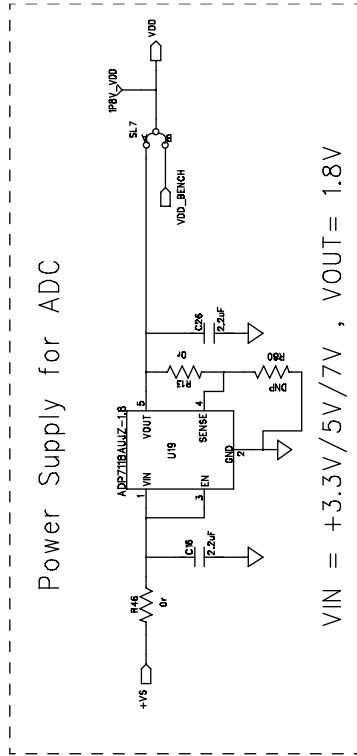
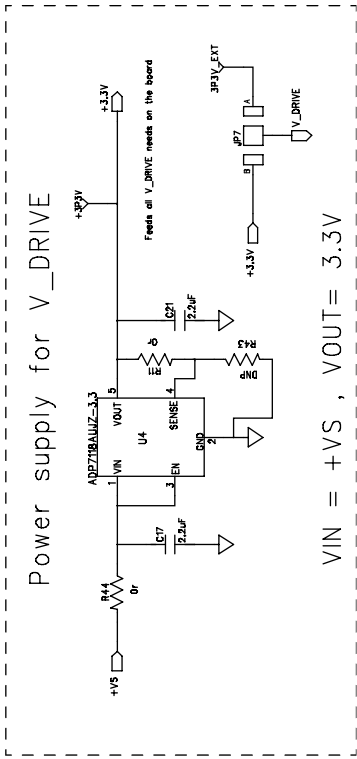

Figure 24. EVAL-AD4000x-FMCG, Power Supplies

14481-023



FMC-LPC Male 160-Pin Connector

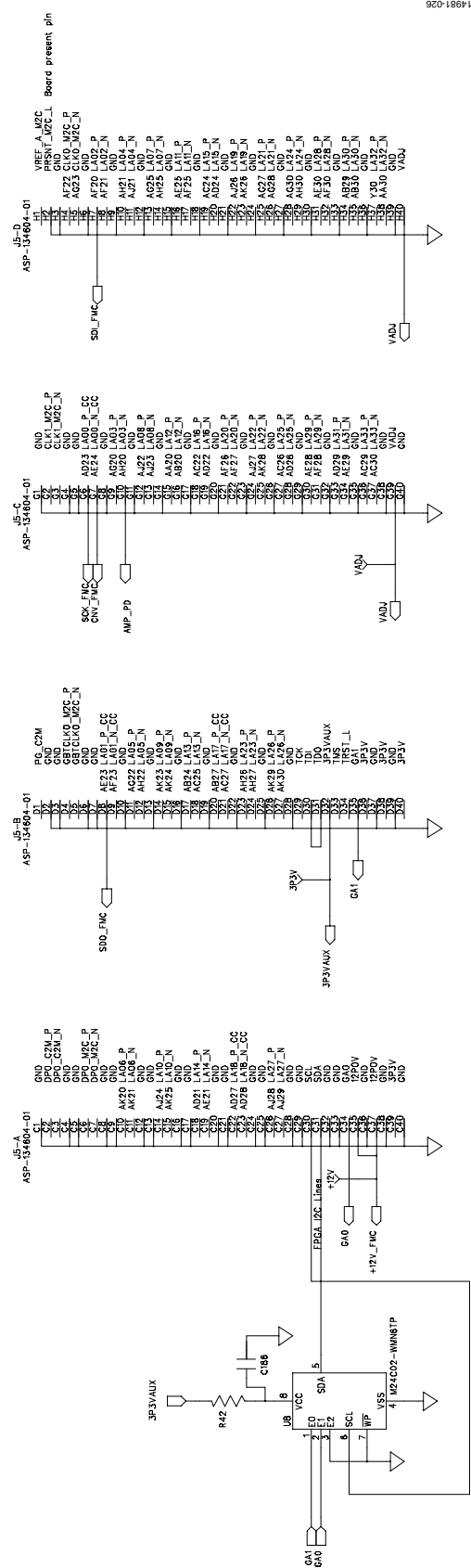

Figure 27. EVAL-AD400x-FMCZ, EVAL-SDP-CH1Z Connector

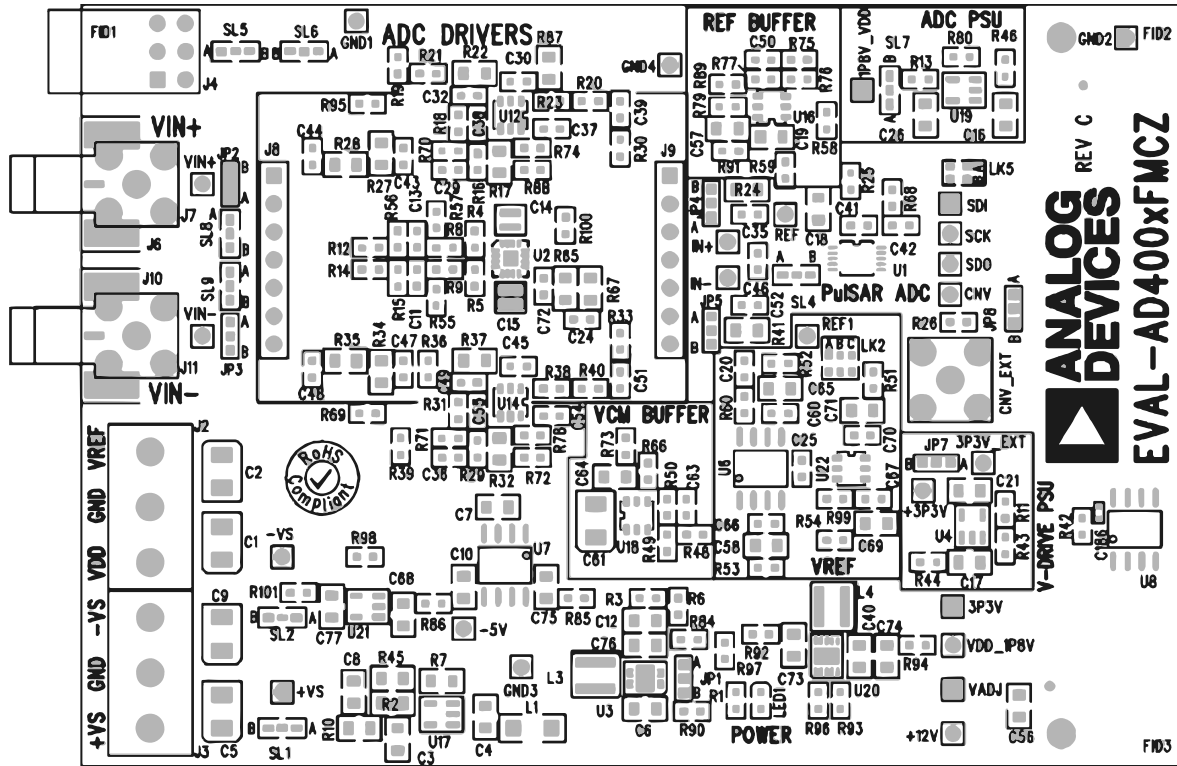

Figure 28. EVAL-AD400x-FMCZ Silkscreen, Top Layer

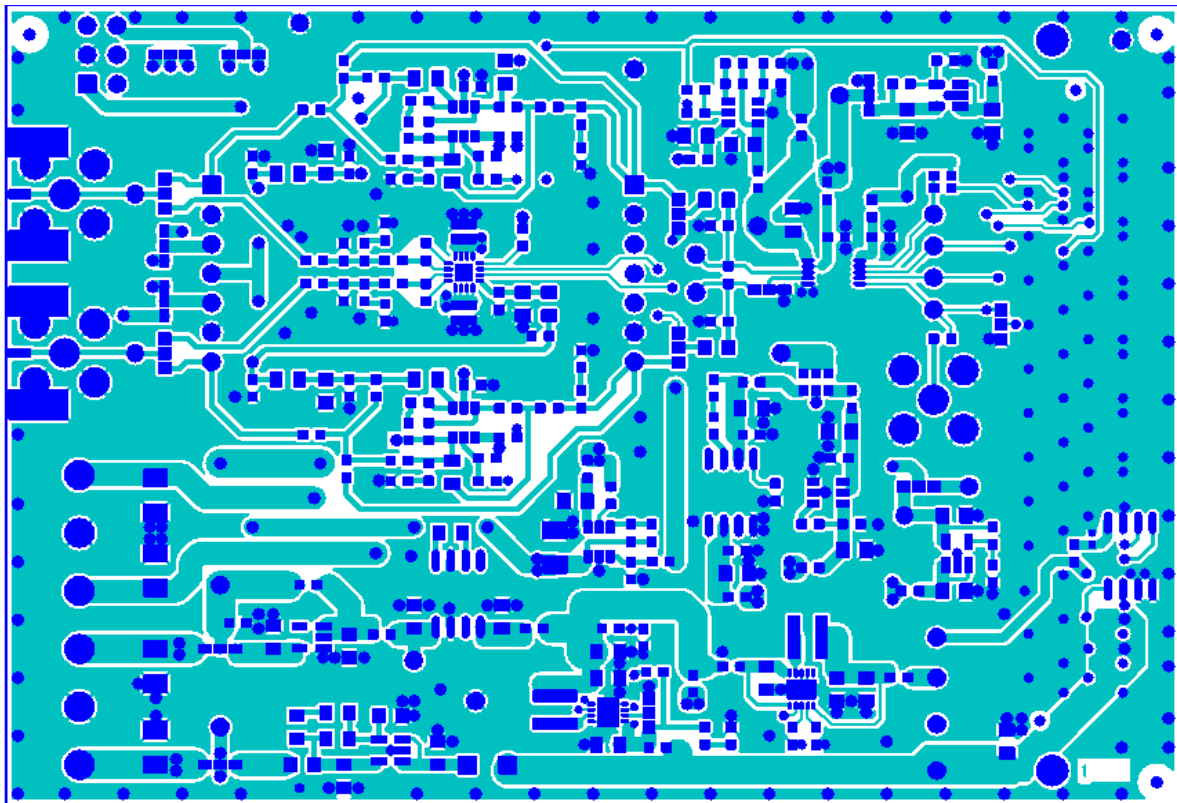
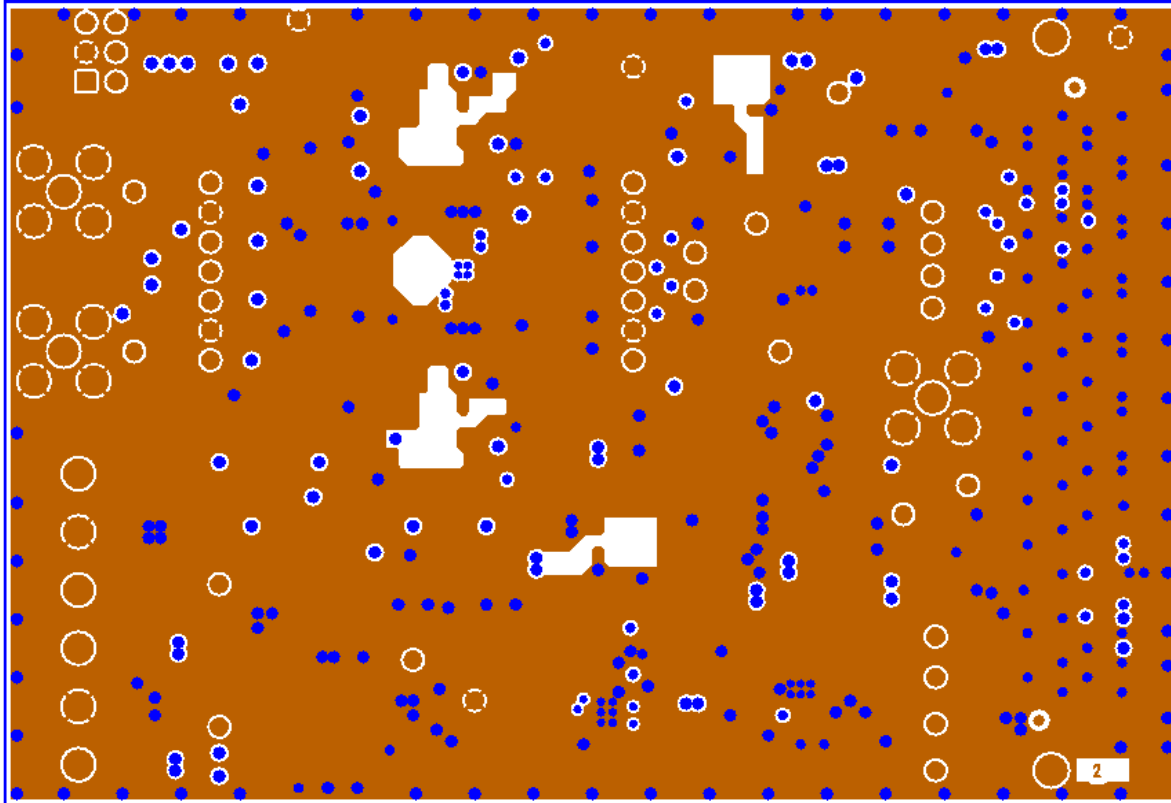
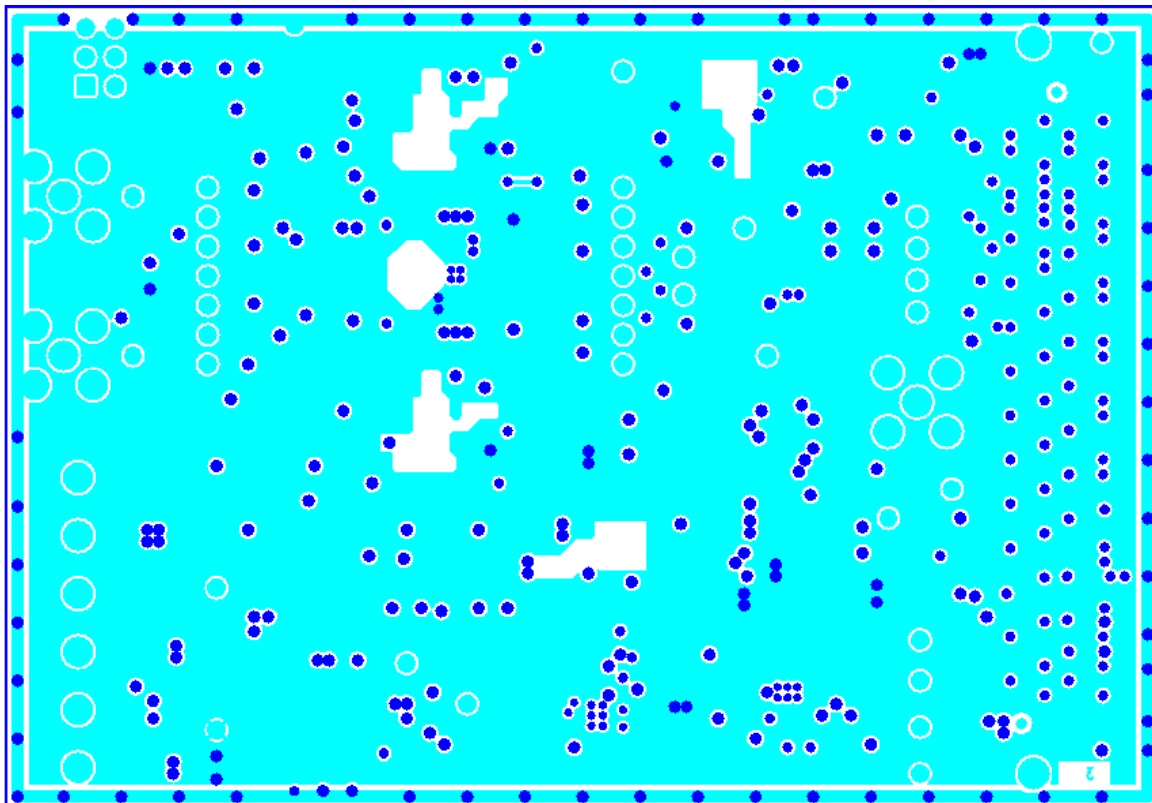

Figure 29. EVAL-AD400x-FMCZ, Layer 1



14881-029

Figure 30. EVAL-AD400x-FMCZ, Layer 2



14881-030

Figure 31. EVAL-AD400x-FMCZ, Layer 3

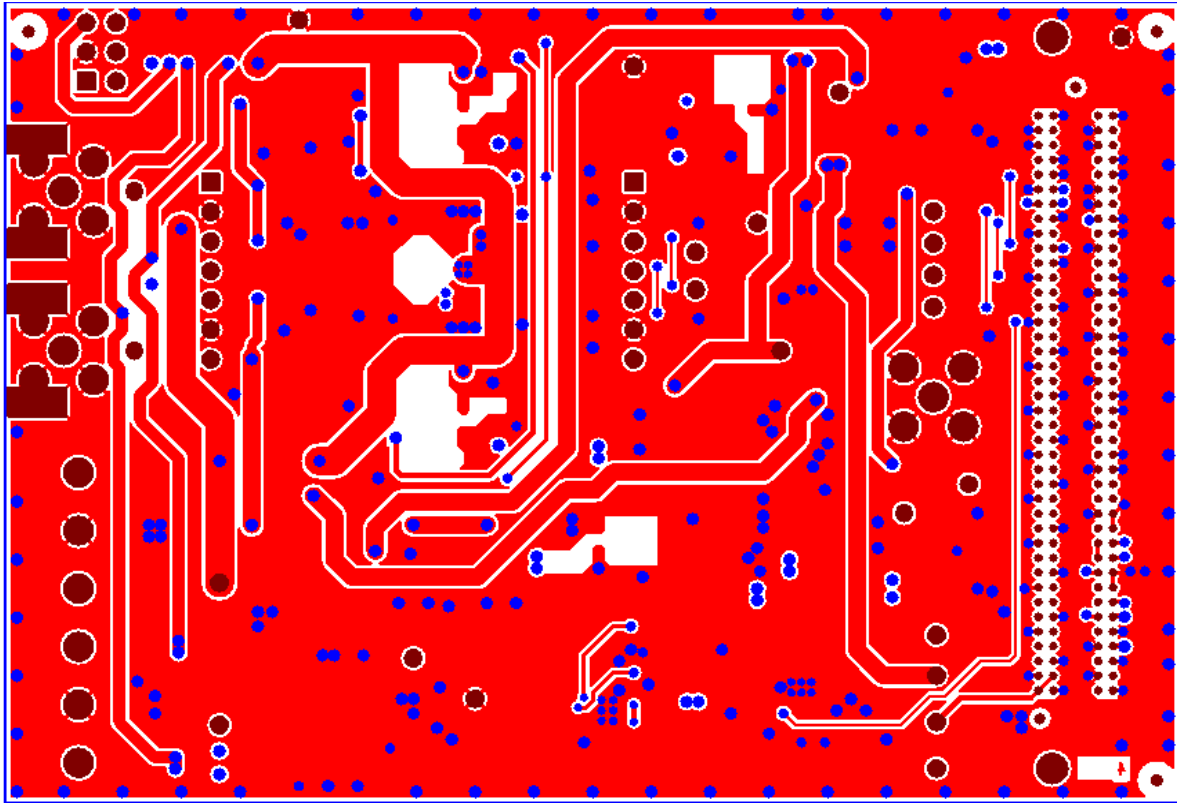

Figure 32. EVAL-AD400x-FMCZ, Layer 4

14981-031

ORDERING INFORMATION

EVALUATION BOARD BILL OF MATERIALS

Table 6. Bill of Materials

Reference Designator	Description	Manufacturer	Part Number	Stock Code
U1	16-/18-bit, 2 MSPS or 20-bit, 1.8 MSPS precision SAR ADC in 10-lead mini small outline package (MSOP)	Analog Devices	See Table 7	See Table 7
U2	Ultralow power, low distortion ADC driver, 4 nV/√Hz	Analog Devices	ADA4940-1	Do not place
U3	High voltage, 1.2 MHz/600 kHz, 800 mA, low quiescent current buck regulator	Analog Devices	ADP2370	ADP2370ACPZ-5.0-R7
U4	Linear regulator, 3.3 V, ultralow noise, complementary metal-oxide semiconductor (CMOS)	Analog Devices	ADP7118	ADP7118AUJZ-3.3-R7
U6	Ultralow noise, high accuracy voltage reference	Analog Devices	ADR4550	ADR4550BRZ
U7	CMOS, switched capacitor voltage converter	Analog Devices	ADM660	ADM660ARZ
U8	IC EEPROM, 2 kb, 400 kHz, 8-lead small outline integrated circuit (SOIC)	ST	M24C02-WMN6TP	Digi-Key 497-8552-1-ND
U12, U14 (only for AD4001/AD4002/AD4003/AD4020)	Low noise, high speed amplifier	Analog Devices	ADA4807-1	ADA4807-1ARJZ
U12, U14 (only for AD4000)	Low noise, high speed amplifier	Analog Devices	ADA4805-1	ADA4805-1ARJZ
U16, U18	Low noise, high speed amplifier	Analog Devices	ADA4807-1	ADA4807-1ARJZ
U17	Linear regulator, 3.3 V, ultralow noise, CMOS	Analog Devices	ADP7118	ADP7118AUJZ-3.3-R7
U19	Linear regulator, 1.8 V, ultralow noise, CMOS	Analog Devices	ADP7118	ADP7118AUJZ-1.8-R7
U20	Ultralow power step-down regulator	Analog Devices	ADP5300	ADP5300ACPZ-1-R7
U21	-28 V, -200 mA, low noise, linear regulator	Analog Devices	ADP7182	ADP7182AUJ-2.5-R7
U22	Micropower, high accuracy, 5 V voltage reference	Analog Devices	ADR3450	ADR3450ARJZ-R2
C1, C2, C5, C9, C61	10 μF, 20 V tantalum capacitor	AVX	TAJB106K020RNJ	FEC 197427
C3, C4, C16, C17, C21, C26	2.2 μF, X7R, 16 V, 0805 capacitor, multilayer ceramic capacitor (MLCC)	Murata	GRM21BR71C225KA12L	FEC 1828829
C6	4.7 μF, 16 V, X7R, 0805 ceramic capacitor	Taiyo Yuden	EMK212B7475KG-T	FEC 1853520
C7, C10, C12, C18, C40, C68, C73, C74, C75, C76, C77	10 μF, 16 V, 0805 capacitor	Murata	GRM219R61C106KA73D	FEC 1845747
C8, C57, C64, C69, C71	1 μF, X7R, 50 V, 0805 capacitor	Murata	GRM21BR71H105KA12L	FEC 1735541
C14, C15	100 nF, X7R, 25 V, 0805 capacitor	Murata	LLL216R71E104MA01L	FEC 1294646
C24, C30, C37, C41, C42, C44, C45, C48, C54, C60, C66, C67, C70	0.1 μF, X7R, 50 V ceramic capacitor	Murata	GRM188R71H104KA93D	FEC 8820023
C35, C52	180 pF, 50 V, 0603, C0G/NP0 capacitor	YAGEO (Phycomp)	CC0603JRNPO9BN181	FEC 3019494
C11, C13, C19, C20, C25, C29, C32, C36, C38, C39, C43, C46, C47, C49, C50, C51, C55, C63, C72	SMD capacitor	Not applicable	Not applicable	Do not place
C56	10 μF, X5R, 25 V, 0805, MLCC capacitor	Murata	GRM219R61E106KA12D	FEC 2426961
C58, C65	2.2 μF, 50 V, 0805, X7R capacitor	TDK	C2012X7R1H225K125AC	FEC 2346945
C186	SMD capacitor	EPCOS	B37921C9104K60	Digi-Key 495-3265-1-ND
L1	1000 Ω at 100 MHz, 1206, WE-CBF SMD, EMI suppression ferrite	Würth	742792141	Würth 742792141
L3	10 μH, inductor, shielded power, XAL40 series	Coilcraft	XAL4040-103ME	XAL4040-103ME
L4	2.2 μH, inductor, shielded power, XAL40 series	Coilcraft	XAL4020-222MEB	Coilcraft XAL4020-222MEB

Reference Designator	Description	Manufacturer	Part Number	Stock Code
LED1	LED, SMD, green	OSRAM	LGQ971	Digi-Key 475-1409-1-ND
R1	2.4 k Ω , 0.063 W, 1%, 0603 resistor	Multicomp	MC0063W060312K4	FEC 9330879
R2	100 k Ω , 0.1 W, 1%, 0805 resistor	Multicomp	MC01W08051100K	FEC 9332405
R3, R11, R12, R13, R14, R20, R21, R23, R25, R36, R38, R40, R42, R44, R46, R48, R50, R51, R52, R53, R59, R66, R68, R69, R73, R74, R75, R77, R78, R79, R85, R86, R90, R91, R95, R96, R99, R100	0 Ω , SMD resistor	Multicomp	MC 0.063W 0603 0R	FEC 9331662
R4, R5, R8, R9	1 k Ω , 0.063 W, 1%, 0603 resistor	Multicomp	MC0063W060311K	FEC 9330380
R7	88.7 k Ω , 1%, 0805 resistor	Vishay Draloric	CRCW080588K7FKEA	FEC 2139026
R10	1%, 0805 resistor	Multicomp	MC01W08050R	FEC 9333681
R17, R22, R32, R37	49.9 Ω , 0.1 W, 0.1%, 0805 resistor	Panasonic	RN73C2A49R9BTG	FEC 1140694
R24, R41	200 Ω , 0.1 W, 1%, 0805 resistor	Multicomp	MC01W08051200R	FEC 9332758
R27, R28, R34, R35	Thick film, chip, resistor	Vishay Draloric	CRCW0805590RFKEA	FEC 1653021
R45, R65, R67	10 k Ω , 0.1 W, 1%, 0805 resistor	Multicomp	MC01W0805110K	FEC 9332391
R93	20 k Ω , 0.063 W, 1%, 0603 resistor	Multicomp	MC0063W0603120K	FEC 9330771
R6, R15, R16, R18, R19, R26, R29, R30, R31, R33, R39, R43, R49, R54, R55, R56, R57, R58, R60, R70, R71, R72, R76, R80, R84, R87, R88, R89, R92, R94, R97, R98, R101	SMD resistor, 0603	Not applicable	Not applicable	Do not place
J2, J3	3-pin terminal block (5 mm pitch)	CamdenBoss	CTB5000/3	FEC 151790
J5	160-pin, 10 mm male, VITA 57 connector	Samtec	ASP-134604-01	Samtec ASP-134604-01
J6, J10	Connector, jack end launch PC gold SMA	Emerson	142-0701-851	Digikey J658-ND
J8	7-way, SSW, 2.54 mm, vertical socket	Samtec	SSW-107-01-T-S	FEC 1803478
J9	7-way, SIP, 2.54 mm, TH header	Samtec	TLW-107-05-G-S	FEC 1668499

Table 7. Evaluation Board Models

Product	Ordering Model	Maximum Throughput (MSPS)	Input Type	Sample Rate (MSPS)	Resolution (Bits)	Package Used on Evaluation Board
AD4000BRMZ	EVAL-AD4000FMCZ	2	Pseudo differential	2	16	10-lead MSOP
AD4001BRMZ	EVAL-AD4001FMCZ	2	Fully differential	2	16	10-lead MSOP
AD4002BRMZ	EVAL-AD4002FMCZ	2	Pseudo differential	2	18	10-lead MSOP
AD4003BRMZ	EVAL-AD4003FMCZ	2	Fully differential	2	18	10-lead MSOP
AD4020BRMZ	EVAL-AD4020FMCZ	1	Fully differential	1.8	20	10-lead MSOP

NOTES

¹C refers to a communications protocol originally developed by Philips Semiconductors (now NXP Semiconductors).

**ESD Caution**

ESD (electrostatic discharge) sensitive device. Charged devices and circuit boards can discharge without detection. Although this product features patented or proprietary protection circuitry, damage may occur on devices subjected to high energy ESD. Therefore, proper ESD precautions should be taken to avoid performance degradation or loss of functionality.

Legal Terms and Conditions

By using the evaluation board discussed herein (together with any tools, components documentation or support materials, the "Evaluation Board"), you are agreeing to be bound by the terms and conditions set forth below ("Agreement") unless you have purchased the Evaluation Board, in which case the Analog Devices Standard Terms and Conditions of Sale shall govern. Do not use the Evaluation Board until you have read and agreed to the Agreement. Your use of the Evaluation Board shall signify your acceptance of the Agreement. This Agreement is made by and between you ("Customer") and Analog Devices, Inc. ("ADI"), with its principal place of business at One Technology Way, Norwood, MA 02062, USA. Subject to the terms and conditions of the Agreement, ADI hereby grants to Customer a free, limited, personal, temporary, non-exclusive, non-sublicensable, non-transferable license to use the Evaluation Board FOR EVALUATION PURPOSES ONLY. Customer understands and agrees that the Evaluation Board is provided for the sole and exclusive purpose referenced above, and agrees not to use the Evaluation Board for any other purpose. Furthermore, the license granted is expressly made subject to the following additional limitations: Customer shall not (i) rent, lease, display, sell, transfer, assign, sublicense, or distribute the Evaluation Board; and (ii) permit any Third Party to access the Evaluation Board. As used herein, the term "Third Party" includes any entity other than ADI, Customer, their employees, affiliates and in-house consultants. The Evaluation Board is NOT sold to Customer; all rights not expressly granted herein, including ownership of the Evaluation Board, are reserved by ADI. CONFIDENTIALITY. This Agreement and the Evaluation Board shall all be considered the confidential and proprietary information of ADI. Customer may not disclose or transfer any portion of the Evaluation Board to any other party for any reason. Upon discontinuation of use of the Evaluation Board or termination of this Agreement, Customer agrees to promptly return the Evaluation Board to ADI. ADDITIONAL RESTRICTIONS. Customer may not disassemble, decompile or reverse engineer chips on the Evaluation Board. Customer shall inform ADI of any occurred damages or any modifications or alterations it makes to the Evaluation Board, including but not limited to soldering or any other activity that affects the material content of the Evaluation Board. Modifications to the Evaluation Board must comply with applicable law, including but not limited to the RoHS Directive. TERMINATION. ADI may terminate this Agreement at any time upon giving written notice to Customer. Customer agrees to return to ADI the Evaluation Board at that time. LIMITATION OF LIABILITY. THE EVALUATION BOARD PROVIDED HEREUNDER IS PROVIDED "AS IS" AND ADI MAKES NO WARRANTIES OR REPRESENTATIONS OF ANY KIND WITH RESPECT TO IT. ADI SPECIFICALLY DISCLAIMS ANY REPRESENTATIONS, ENDORSEMENTS, GUARANTEES, OR WARRANTIES, EXPRESS OR IMPLIED, RELATED TO THE EVALUATION BOARD INCLUDING, BUT NOT LIMITED TO, THE IMPLIED WARRANTY OF MERCHANTABILITY, TITLE, FITNESS FOR A PARTICULAR PURPOSE OR NON-INFRINGEMENT OF INTELLECTUAL PROPERTY RIGHTS. IN NO EVENT WILL ADI AND ITS LICENSORS BE LIABLE FOR ANY INCIDENTAL, SPECIAL, INDIRECT, OR CONSEQUENTIAL DAMAGES RESULTING FROM CUSTOMER'S POSSESSION OR USE OF THE EVALUATION BOARD, INCLUDING BUT NOT LIMITED TO LOST PROFITS, DELAY COSTS, LABOR COSTS OR LOSS OF GOODWILL. ADI'S TOTAL LIABILITY FROM ANY AND ALL CAUSES SHALL BE LIMITED TO THE AMOUNT OF ONE HUNDRED US DOLLARS (\$100.00). EXPORT. Customer agrees that it will not directly or indirectly export the Evaluation Board to another country, and that it will comply with all applicable United States federal laws and regulations relating to exports. GOVERNING LAW. This Agreement shall be governed by and construed in accordance with the substantive laws of the Commonwealth of Massachusetts (excluding conflict of law rules). Any legal action regarding this Agreement will be heard in the state or federal courts having jurisdiction in Suffolk County, Massachusetts, and Customer hereby submits to the personal jurisdiction and venue of such courts. The United Nations Convention on Contracts for the International Sale of Goods shall not apply to this Agreement and is expressly disclaimed.

Looking for pricing, stock, or lifecycle information?

Click below to explore more details on WIN SOURCE:

- ⊖ [View EVAL-AD4003FMCZ on WIN SOURCE](#)
- ⊖ [Analog Devices Inc. Information](#)

Optimize Your Supply Chain with WIN SOURCE Solutions

- ✓ Global Sourcing Solution
- ✓ Obsolete Management
- ✓ Cost Control Management
- ✓ Shortage Management
- ✓ Alternative Solution
- ✓ Excess Inventory Management