



**THE DATASHEET OF
DAC7512E/2K5**





Low-Power, Rail-to-Rail Output, 12-Bit Serial Input DIGITAL-TO-ANALOG CONVERTER

FEATURES

- **microPOWER OPERATION:** 135 μ A at 5V
- **POWER-DOWN:** 200nA at 5V, 50nA at 3V
- **POWER SUPPLY:** +2.7V to +5.5V
- **TESTED MONOTONIC BY DESIGN**
- **POWER-ON RESET TO 0V**
- **THREE POWER-DOWN FUNCTIONS**
- **LOW POWER SERIAL INTERFACE WITH SCHMITT-TRIGGERED INPUTS**
- **ON-CHIP OUTPUT BUFFER AMPLIFIER, RAIL-TO-RAIL OPERATION**
- **SYNC INTERRUPT FACILITY**
- **SOT23-6 AND MSOP-8 PACKAGES**

APPLICATIONS

- **PORTABLE BATTERY-POWERED INSTRUMENTS**
- **DIGITAL GAIN AND OFFSET ADJUSTMENT**
- **PROGRAMMABLE VOLTAGE AND CURRENT SOURCES**

DESCRIPTION

The DAC7512 is a low-power, single, 12-bit buffered voltage output Digital-to-Analog Converter (DAC). Its on-chip precision output amplifier allows rail-to-rail output swing to be achieved. The DAC7512 uses a versatile three-wire serial interface that operates at clock rates up to 30MHz and is compatible with standard SPI™, QSPI™, Microwire™, and DSP interfaces.

The reference for the DAC7512 is derived from the power supply, resulting in the widest dynamic output range possible. The DAC7512 incorporates a power-on reset circuit that ensures that the DAC output powers up at 0V and remains there until a valid write takes place in the device. The DAC7512 contains a power-down feature, accessed over the serial interface, that can reduce the current consumption of the device to 50nA at 5V.

The low power consumption of this part in normal operation makes it ideally suited to portable battery-operated equipment. The power consumption is 0.7mW at 5V reducing to 1 μ W in power-down mode.

The DAC7512 is available in a SOT23-6 package and an MSOP-8 package.

SPI and QSPI are registered trademarks of Motorola.
Microwire is a registered trademark of National Semiconductor.

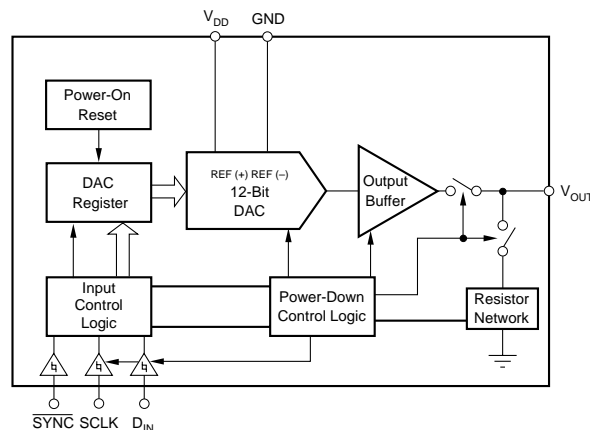

Please be aware that an important notice concerning availability, standard warranty, and use in critical applications of Texas Instruments semiconductor products and disclaimers thereto appears at the end of this data sheet.

ABSOLUTE MAXIMUM RATINGS⁽¹⁾

| | |
|---|---|
| V_{DD} to GND | -0.3V to +6V |
| Digital Input Voltage to GND | -0.3V to $V_{DD} + 0.3V$ |
| V_{OUT} to GND | -0.3V to $V_{DD} + 0.3V$ |
| Operating Temperature Range | -40°C to +105°C |
| Storage Temperature Range | -65°C to +150°C |
| Junction Temperature Range (T_J max) | +150°C |
| SOT23 Package: | |
| Power Dissipation | $(T_J \text{ max} - T_A) / \theta_{JA}$ |
| θ_{JA} Thermal Impedance | 240°C/W |
| Lead Temperature, Soldering: | |
| Vapor Phase (60s) | +215°C |
| Infrared (15s) | +220°C |
| MSOP Package: | |
| Power Dissipation | $(T_J \text{ max} - T_A) / \theta_{JA}$ |
| θ_{JA} Thermal Impedance | 206°C/W |
| θ_{JC} Thermal Impedance | 44°C/W |
| Lead Temperature, Soldering: | |
| Vapor Phase (60s) | +215°C |
| Infrared (15s) | +220°C |

NOTE: (1) Stresses above those listed under "Absolute Maximum Ratings" may cause permanent damage to the device. Exposure to absolute maximum conditions for extended periods may affect device reliability.

PACKAGE/ORDERING INFORMATION

| PRODUCT | MINIMUM RELATIVE ACCURACY (LSB) | DIFFERENTIAL NONLINEARITY (LSB) | PACKAGE-LEAD | PACKAGE DESIGNATOR ⁽¹⁾ | SPECIFIED TEMPERATURE RANGE | PACKAGE MARKING | ORDERING NUMBER ⁽¹⁾ | TRANSPORT MEDIA, QUANTITY |
|----------|---------------------------------|---------------------------------|--------------|-----------------------------------|-----------------------------|-----------------|--------------------------------|---------------------------|
| DAC7512E | ±8 | ±1 | MSOP-8 | DGK | -40°C to +105°C | D12E | DAC7512E/250 | Tape and Reel, 250 |
| " | " | " | " | " | " | " | DAC7512E/2K5 | Tape and Reel, 2500 |
| DAC7512N | ±8 | ±1 | SOT23-6 | DBV | -40°C to +105°C | D12N | DAC7512N/250 | Tape and Reel, 250 |
| " | " | " | " | " | " | " | DAC7512N/3K | Tape and Reel, 3000 |

NOTES: (1) For the most current specifications and package information, refer to our web site at www.ti.com. (2) Models with a slash (/) are available only in Tape and Reel in the quantities indicated (e.g., /2K5 indicates 2500 devices per reel). Ordering 2500 pieces of "DAC7512E/2K5" will get a single 2500-piece Tape and Reel.

PIN CONFIGURATIONS

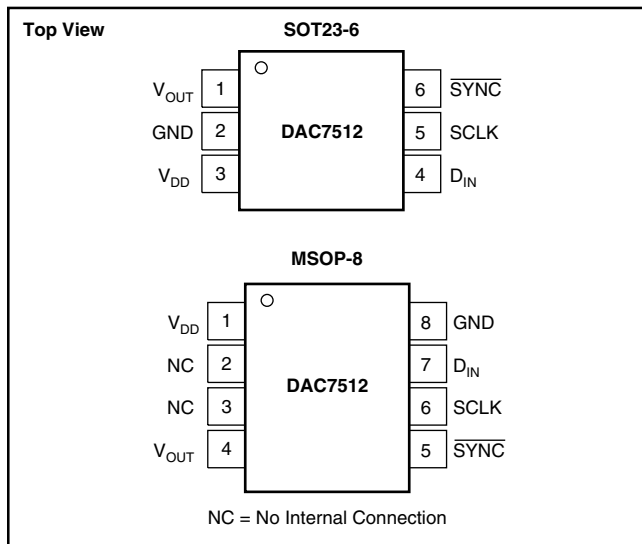

ELECTROSTATIC DISCHARGE SENSITIVITY

This integrated circuit can be damaged by ESD. Texas Instruments recommends that all integrated circuits be handled with appropriate precautions. Failure to observe proper handling and installation procedures can cause damage.

ESD damage can range from subtle performance degradation to complete device failure. Precision integrated circuits may be more susceptible to damage because very small parametric changes could cause the device not to meet its published specifications.

PIN DESCRIPTION (SOT23-6)

| PIN | NAME | DESCRIPTION |
|-----|-------------------|---|
| 1 | V_{OUT} | Analog output voltage from DAC. The output amplifier has rail-to-rail operation. |
| 2 | GND | Ground reference point for all circuitry on the part. |
| 3 | V_{DD} | Power Supply Input, +2.7V to 5.5V. |
| 4 | D_{IN} | Serial Data Input. Data is clocked into the 16-bit input shift register on the falling edge of the serial clock input. |
| 5 | SCLK | Serial Clock Input. Data can be transferred at rates up to 30MHz. |
| 6 | \overline{SYNC} | Level triggered control input (active LOW). This is the frame synchronization signal for the input data. When \overline{SYNC} goes LOW, it enables the input shift register and data is transferred in on the falling edges of the following clocks. The DAC is updated following the 16th clock cycle unless \overline{SYNC} is taken HIGH before this edge, in which case the rising edge of \overline{SYNC} acts as an interrupt and the write sequence is ignored by the DAC7512. |

DAC7512N LOT TRACE LOCATION

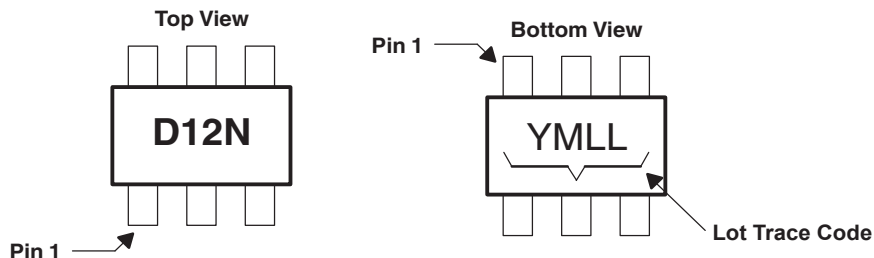

ELECTRICAL CHARACTERISTICS

$V_{DD} = +2.7V$ to $+5.5V$; $R_L = 2k\Omega$ to GND; $C_L = 200pF$ to GND.

| PARAMETER | CONDITIONS | DAC7512E, N | | | UNITS |
|--|--|-------------|-------|------------|-------------------------|
| | | MIN | TYP | MAX | |
| STATIC PERFORMANCE ⁽¹⁾ | | | | | |
| Resolution | | 12 | | | Bits |
| Relative Accuracy | | | | ± 8 | LSB |
| Differential Nonlinearity | Tested Monotonic by Design | | | ± 1 | LSB |
| Zero Code Error | All Zeroes Loaded to DAC Register | | +5 | +20 | mV |
| Full-Scale Error | All Ones Loaded to DAC Register | | -0.15 | -1.25 | % of FSR |
| Gain Error | | | | ± 1.25 | % of FSR |
| Zero Code Error Drift | | | -20 | | $\mu V/^{\circ}C$ |
| Gain Temperature Coefficient | | | -5 | | ppm of FSR/ $^{\circ}C$ |
| OUTPUT CHARACTERISTICS ⁽²⁾ | | | | | |
| Output Voltage Range | | 0 | | V_{DD} | V |
| Output Voltage Settling Time | 1/4 Scale to 3/4 Scale Change (400 _H to C00 _H) | | 8 | 10 | μs |
| | $R_L = 2k\Omega$; $0pF < C_L < 200pF$ | | 12 | | μs |
| Slew Rate | $R_L = 2k\Omega$; $C_L = 500pF$ | 1 | | | V/ μs |
| Capacitive Load Stability | $R_L = x$ | | 470 | | pF |
| | $R_L = 2k\Omega$ | | 1000 | | pF |
| Code Change Glitch Impulse | 1LSB Change Around Major Carry | | 20 | | nV-s |
| Digital Feedthrough | | | 0.5 | | nV-s |
| DC Output Impedance | | | 1 | | Ω |
| Short-Circuit Current | $V_{DD} = +5V$ | | 50 | | mA |
| | $V_{DD} = +3V$ | | 20 | | mA |
| Power-Up Time | Coming Out of Power-Down Mode | | | | |
| | $V_{DD} = +5V$ | | 2.5 | | μs |
| | Coming Out of Power-Down Mode | | | | |
| | $V_{DD} = +3V$ | | 5 | | μs |
| LOGIC INPUTS ⁽²⁾ | | | | | |
| Input Current | | | | ± 1 | μA |
| V_{INL} , Input Low Voltage | $V_{DD} = +5V$ | | | 0.8 | V |
| V_{INL} , Input Low Voltage | $V_{DD} = +3V$ | | | 0.6 | V |
| V_{INH} , Input High Voltage | $V_{DD} = +5V$ | 2.4 | | | V |
| V_{INH} , Input High Voltage | $V_{DD} = +3V$ | 2.1 | | | V |
| Pin Capacitance | | | | 3 | pF |
| POWER REQUIREMENTS | | | | | |
| V_{DD} | | 2.7 | | 5.5 | V |
| I_{DD} (normal mode) | DAC Active and Excluding Load Current | | | | |
| $V_{DD} = +3.6V$ to $+5.5V$ | $V_{IH} = V_{DD}$ and $V_{IL} = GND$ | | 135 | 200 | μA |
| $V_{DD} = +2.7V$ to $+3.6V$ | $V_{IH} = V_{DD}$ and $V_{IL} = GND$ | | 115 | 160 | μA |
| I_{DD} (all power-down modes) | | | | | |
| $V_{DD} = +3.6V$ to $+5.5V$ | $V_{IH} = V_{DD}$ and $V_{IL} = GND$ | | 0.2 | 1 | μA |
| $V_{DD} = +2.7V$ to $+3.6V$ | $V_{IH} = V_{DD}$ and $V_{IL} = GND$ | | 0.05 | 1 | μA |
| POWER EFFICIENCY | | | | | |
| I_{OUT}/I_{DD} | $I_{LOAD} = 2mA$. $V_{DD} = +5V$ | | 93 | | % |
| TEMPERATURE RANGE | | | | | |
| Specified Performance | | -40 | | +105 | $^{\circ}C$ |

NOTES: (1) Linearity calculated using a reduced code range of 48 to 4047; output unloaded. (2) Guaranteed by design and characterization, not production tested.

TIMING CHARACTERISTICS(1, 2)

$V_{DD} = +2.7V$ to $+5.5V$; all specifications $-40^{\circ}C$ to $+105^{\circ}C$, unless otherwise noted.

| PARAMETER | DESCRIPTION | CONDITIONS | DAC7512E, N | | | UNITS |
|-------------|--|--|-------------|-----|-----|----------|
| | | | MIN | TYP | MAX | |
| $t_1^{(3)}$ | SCLK Cycle Time | $V_{DD} = 2.7V$ to $3.6V$ $V_{DD} = 3.6V$ to $5.5V$ | 50 33 | | | ns ns |
| t_2 | SCLK HIGH Time | $V_{DD} = 2.7V$ to $3.6V$ $V_{DD} = 3.6V$ to $5.5V$ | 13 13 | | | ns ns |
| t_3 | SCLK LOW Time | $V_{DD} = 2.7V$ to $3.6V$ $V_{DD} = 3.6V$ to $5.5V$ | 22.5 13 | | | ns ns |
| t_4 | \overline{SYNC} to SCLK Rising Edge Setup Time | $V_{DD} = 2.7V$ to $3.6V$ $V_{DD} = 3.6V$ to $5.5V$ | 0 0 | | | ns ns |
| t_5 | Data Setup Time | $V_{DD} = 2.7V$ to $3.6V$ $V_{DD} = 3.6V$ to $5.5V$ | 5 5 | | | ns ns |
| t_6 | Data Hold Time | $V_{DD} = 2.7V$ to $3.6V$ $V_{DD} = 3.6V$ to $5.5V$ | 4.5 4.5 | | | ns ns |
| t_7 | SCLK Falling Edge to \overline{SYNC} Rising Edge | $V_{DD} = 2.7V$ to $3.6V$ $V_{DD} = 3.6V$ to $5.5V$ | 0 0 | | | ns ns |
| t_8 | Minimum \overline{SYNC} HIGH Time | $V_{DD} = 2.7V$ to $3.6V$ $V_{DD} = 3.6V$ to $5.5V$ | 50 33 | | | ns ns |

NOTES: (1) All input signals are specified with $t_R = t_F = 5ns$ (10% to 90% of V_{DD}) and timed from a voltage level of $(V_{IL} + V_{IH})/2$. (2) See Serial Write Operation timing diagram, below. (3) Maximum SCLK frequency is 30MHz at $V_{DD} = +3.6V$ to $+5.5V$ and 20MHz at $V_{DD} = +2.7V$ to $+3.6V$.

SERIAL WRITE OPERATION

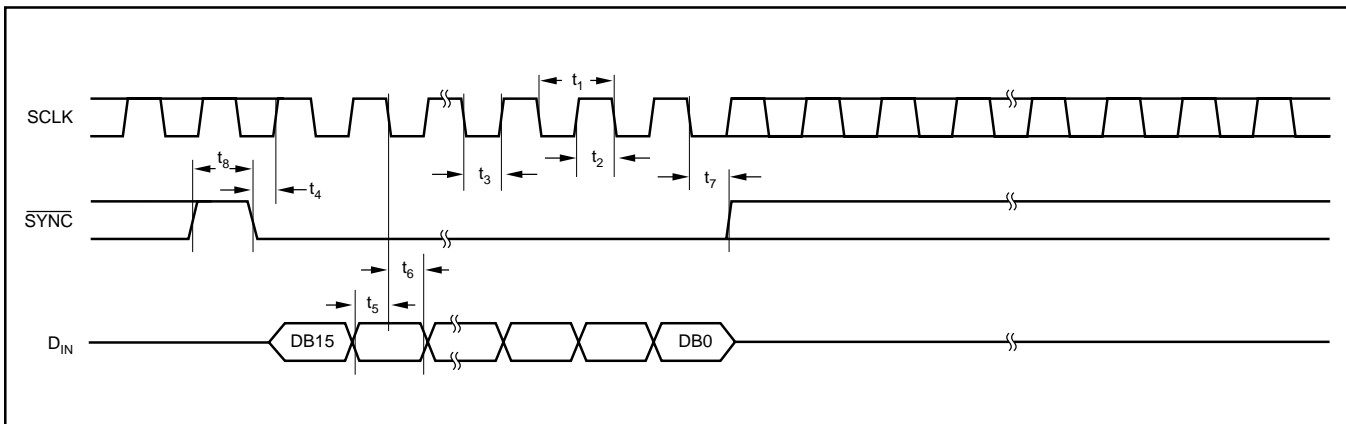

TYPICAL CHARACTERISTICS: $V_{DD} = +5V$

At $T_A = +25^\circ C$, $+V_{DD} = +5V$, unless otherwise noted.

LINEARITY ERROR AND DIFFERENTIAL LINEARITY ERROR vs CODE (-40°C)

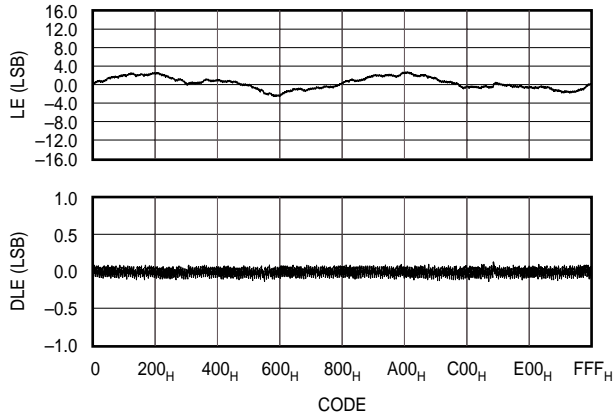

LINEARITY ERROR AND DIFFERENTIAL LINEARITY ERROR vs CODE (+25°C)

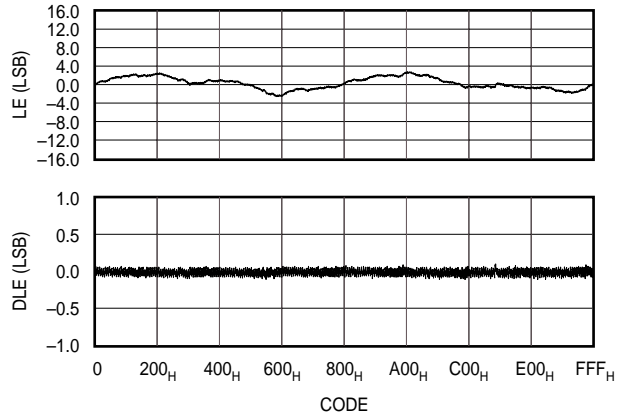

LINEARITY ERROR AND DIFFERENTIAL LINEARITY ERROR vs CODE (+105°C)

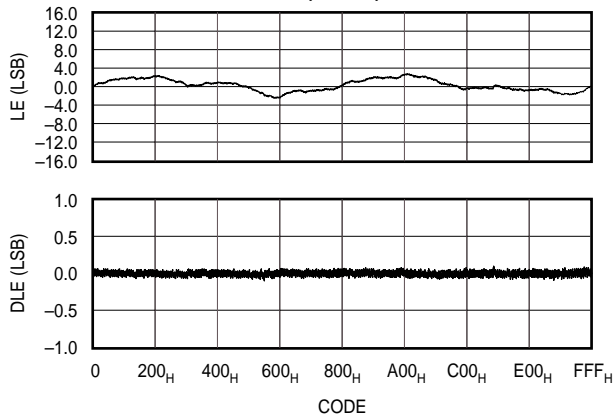

TYPICAL TOTAL UNADJUSTED ERROR

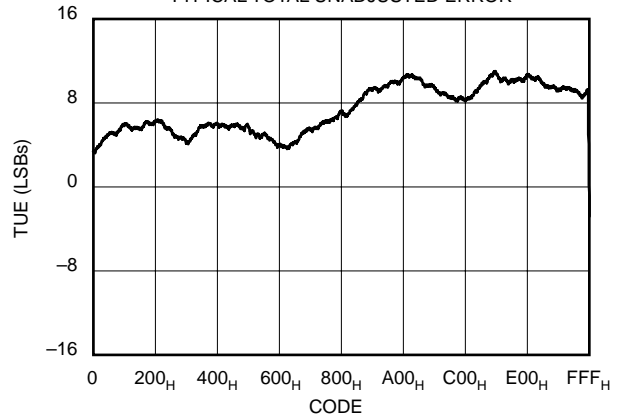

ZERO-SCALE ERROR vs TEMPERATURE

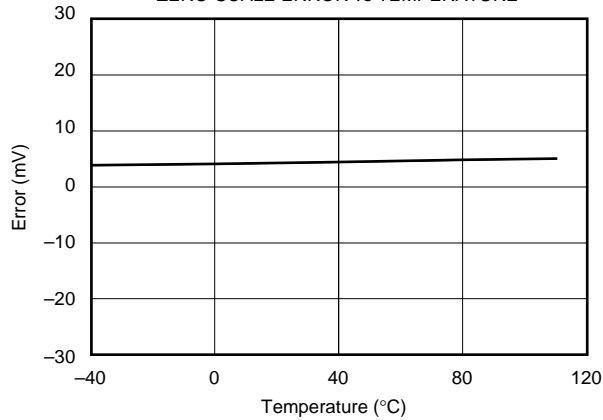

FULL-SCALE ERROR vs TEMPERATURE

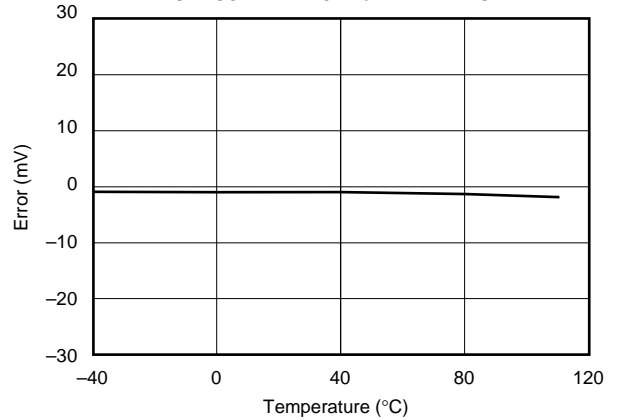

TYPICAL CHARACTERISTICS: $V_{DD} = +5V$ (Cont.)

At $T_A = +25^\circ\text{C}$, $+V_{DD} = +5V$, unless otherwise noted.

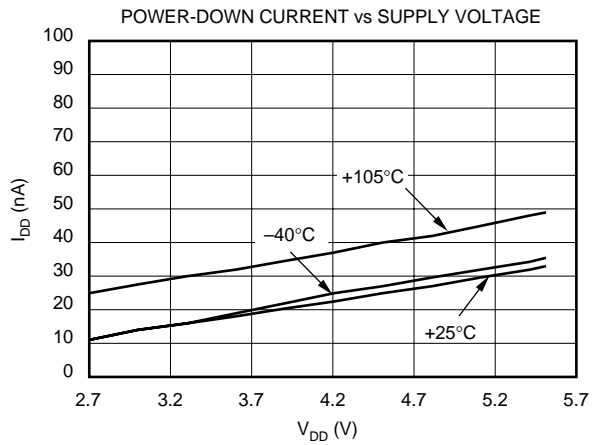
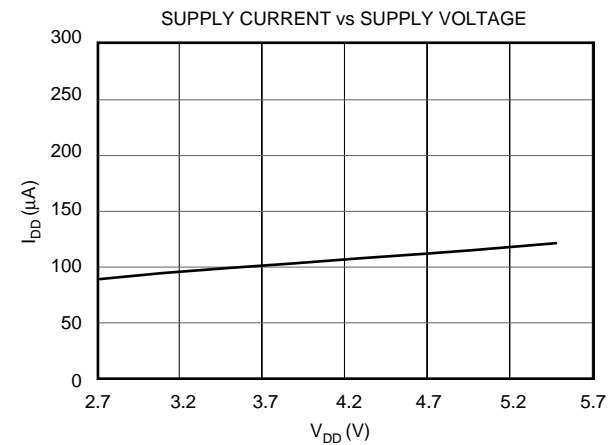
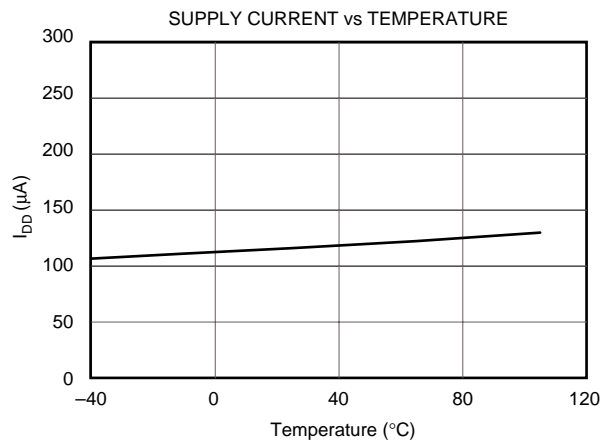
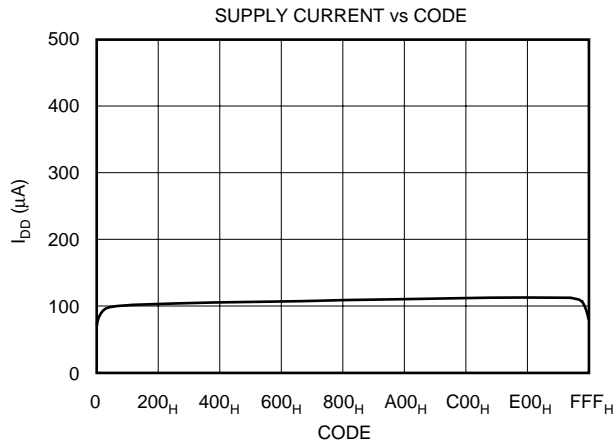
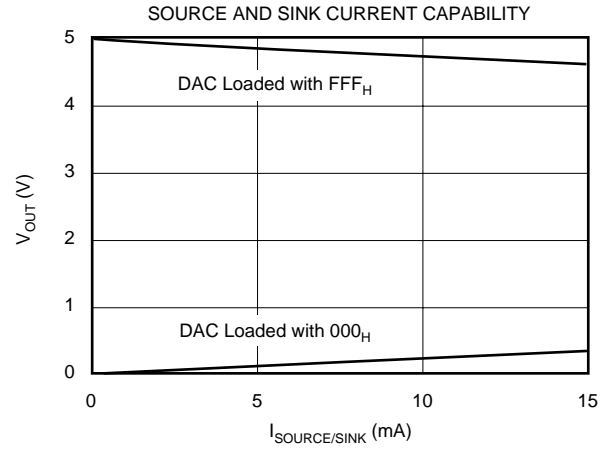
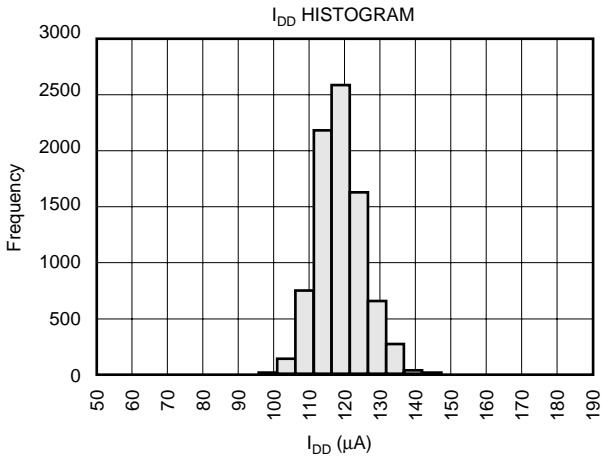

TYPICAL CHARACTERISTICS: $V_{DD} = +5V$ (Cont.)

At $T_A = +25^\circ C$, $+V_{DD} = +5V$, unless otherwise noted.

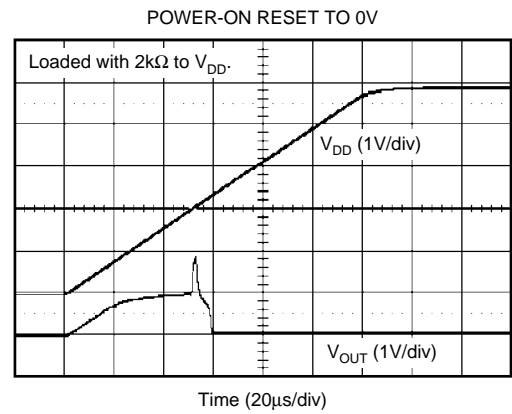
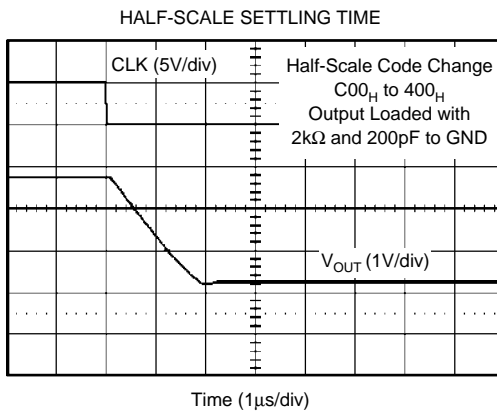
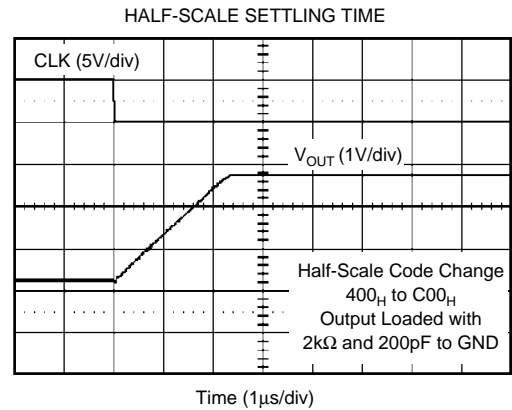
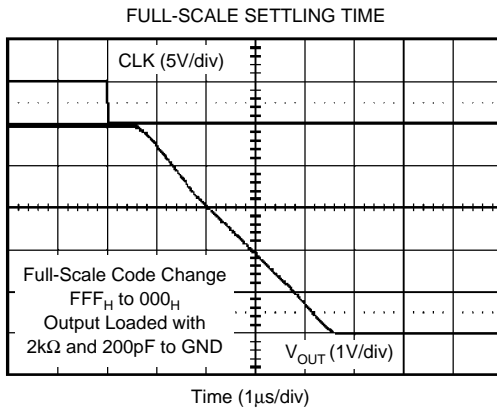
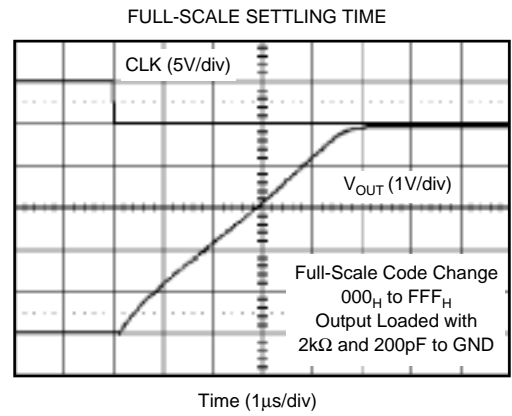
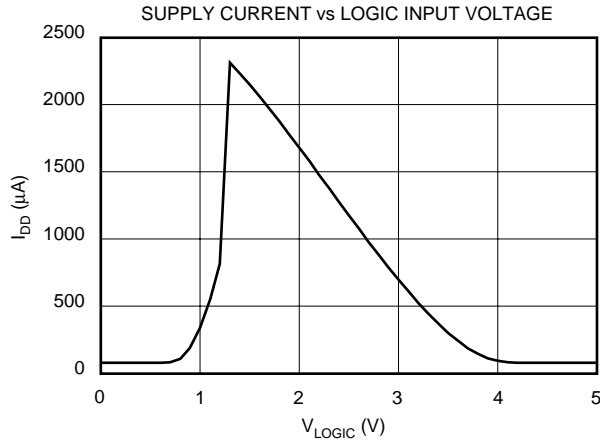

TYPICAL CHARACTERISTICS: $V_{DD} = +5V$ (Cont.)

At $T_A = +25^\circ\text{C}$, $+V_{DD} = +5V$, unless otherwise noted.

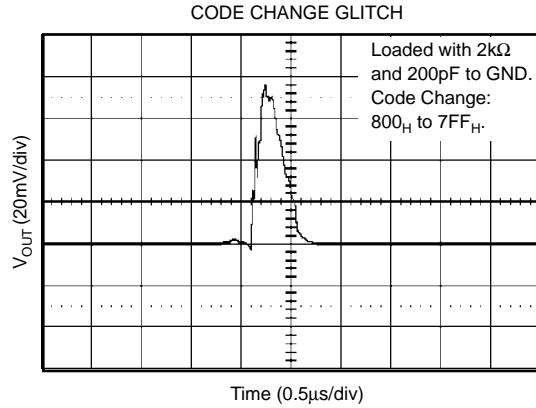
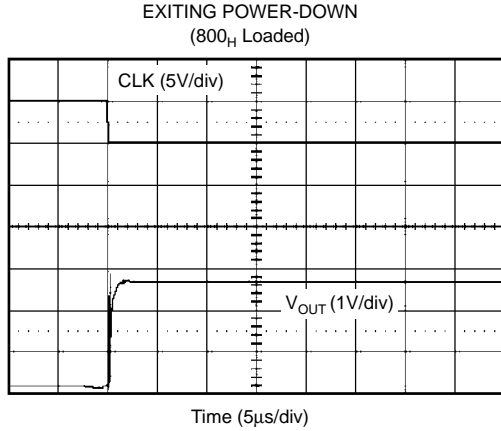

TYPICAL CHARACTERISTICS: $V_{DD} = +2.7V$

At $T_A = +25^\circ\text{C}$, $+V_{DD} = +2.7V$, unless otherwise noted.

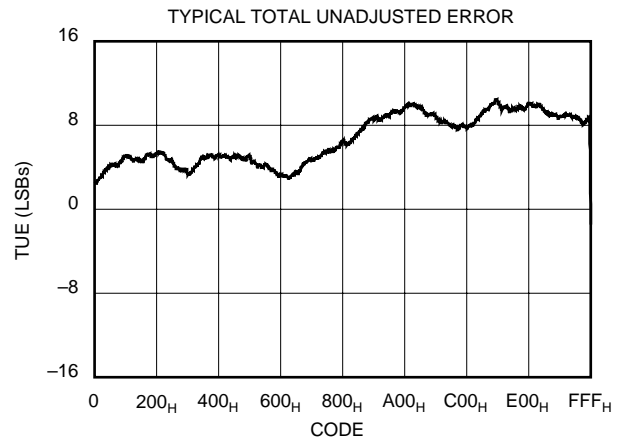
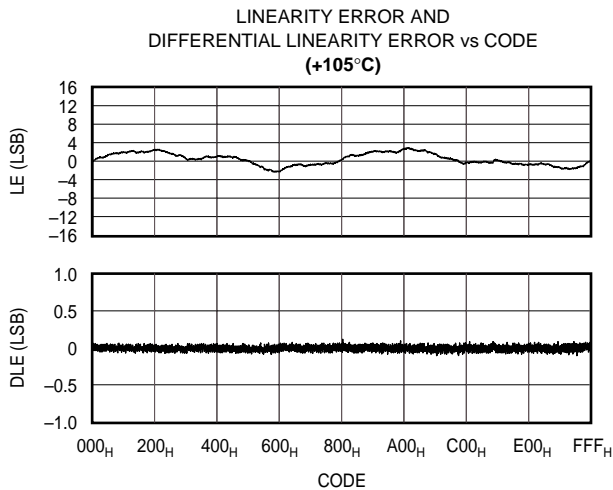
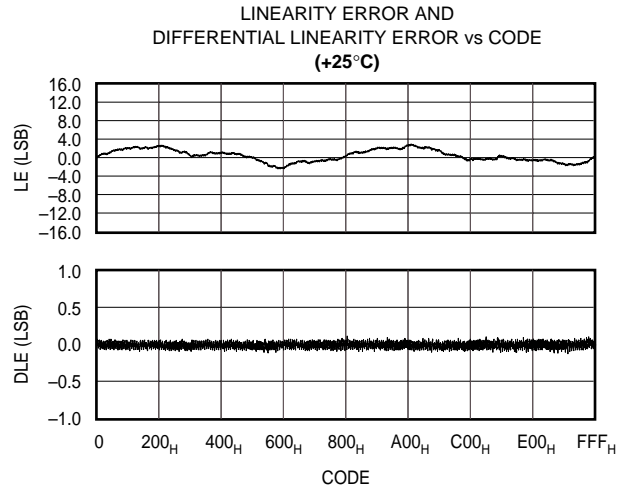
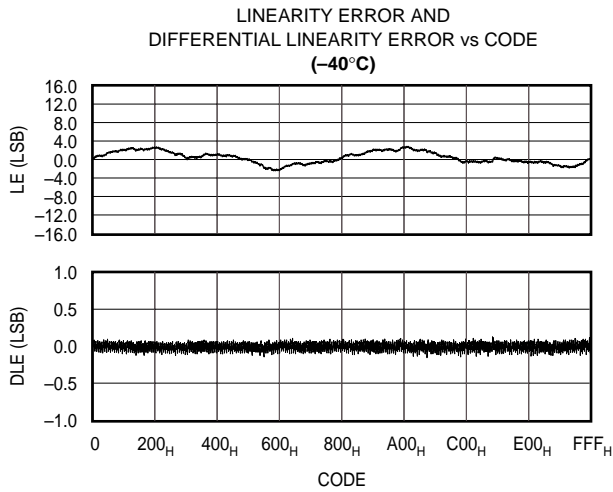

TYPICAL CHARACTERISTICS: $V_{DD} = +2.7V$ (Cont.)

At $T_A = +25^\circ C$, $+V_{DD} = +2.7V$, unless otherwise noted.

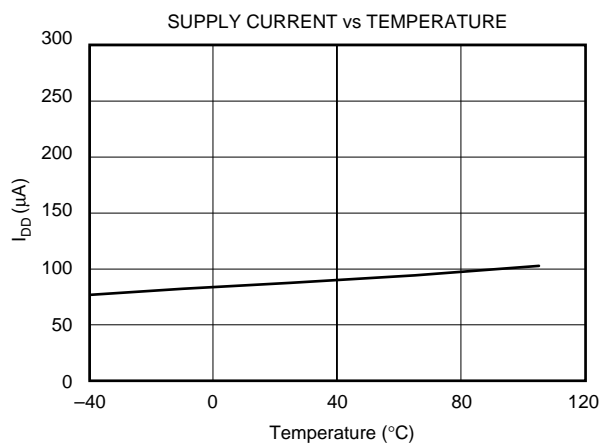
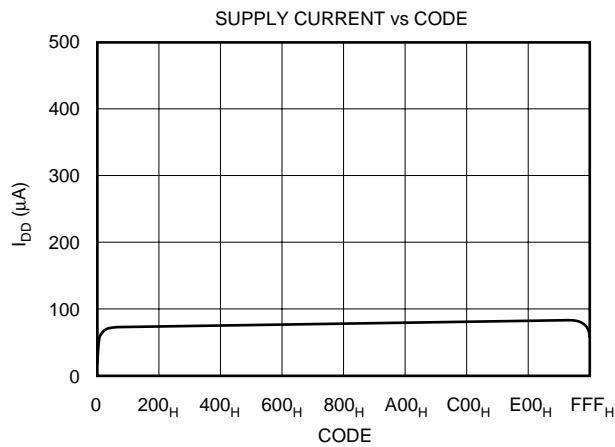
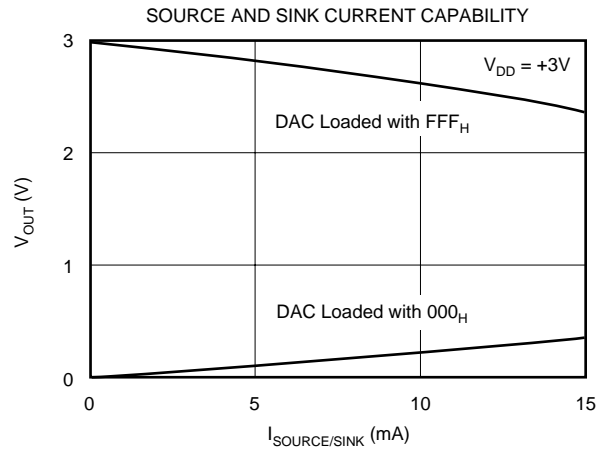
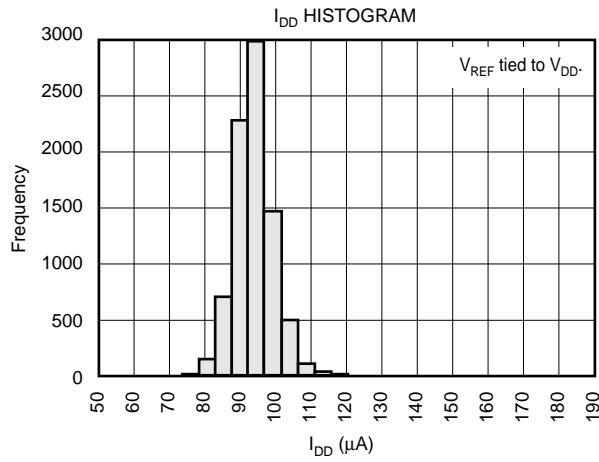
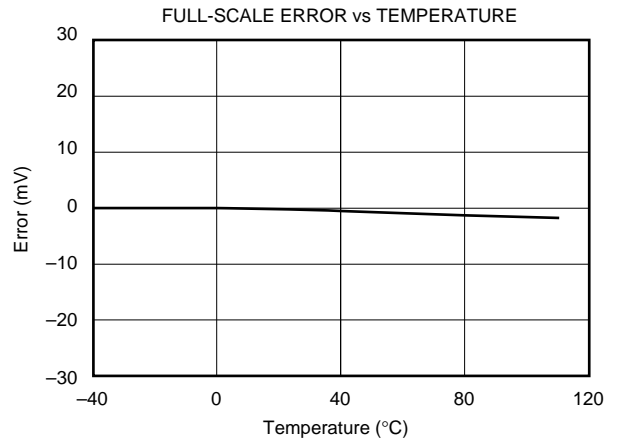
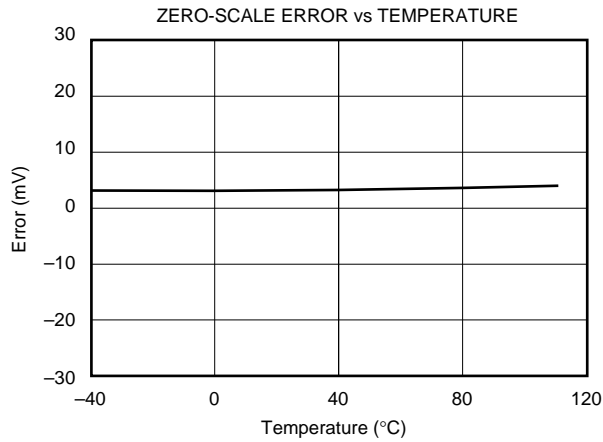

TYPICAL CHARACTERISTICS: $V_{DD} = +2.7V$ (Cont.)

At $T_A = +25^\circ C$, $+V_{DD} = +2.7V$, unless otherwise noted.

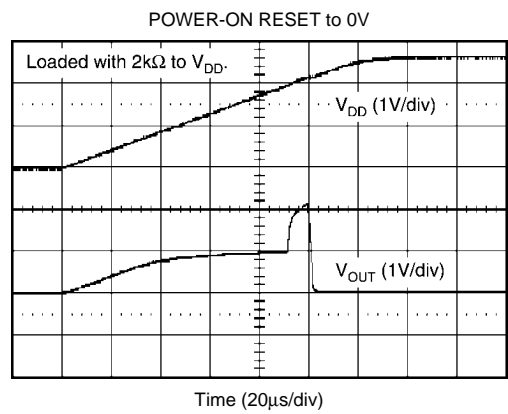
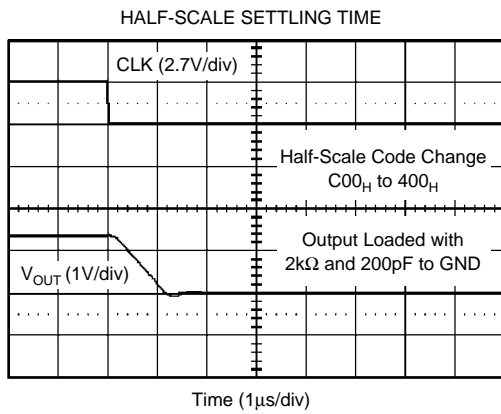
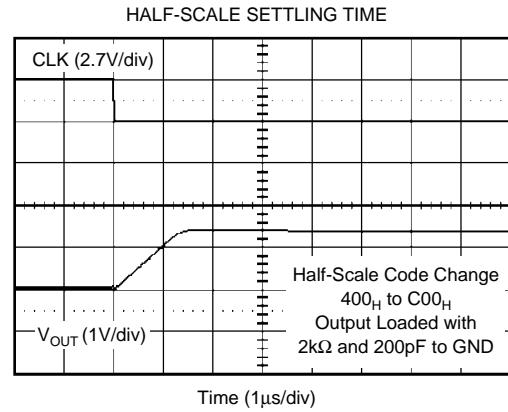
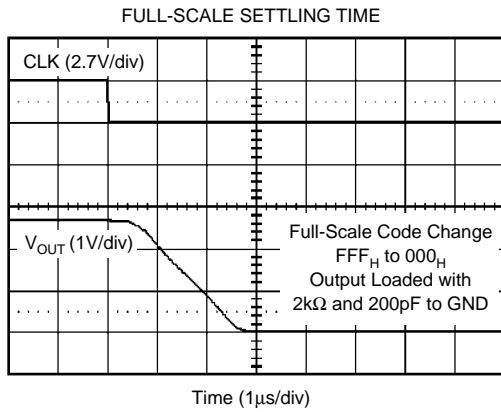
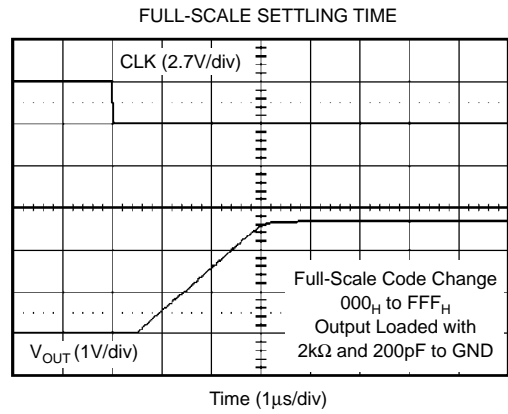
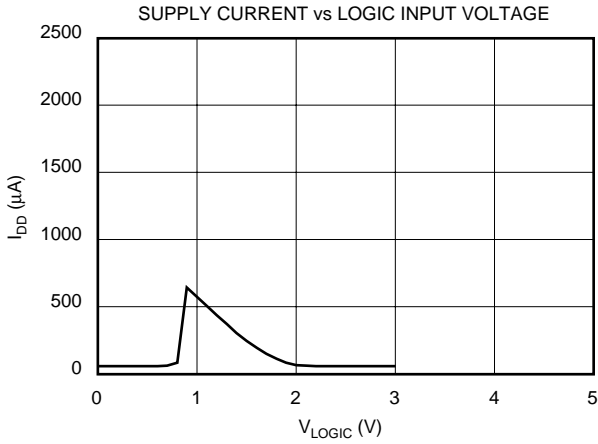

TYPICAL CHARACTERISTICS: $V_{DD} = +2.7V$ (Cont.)

At $T_A = +25^\circ C$, $+V_{DD} = +2.7V$, unless otherwise noted.

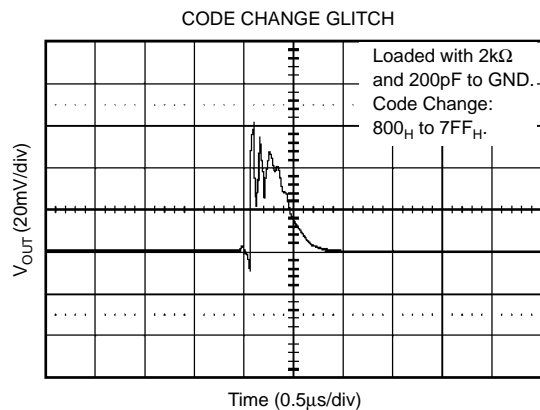
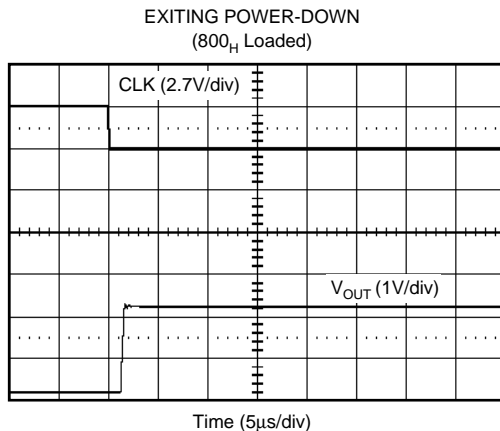

THEORY OF OPERATION

DAC SECTION

The DAC7512 is fabricated using a CMOS process. The architecture consists of a string DAC followed by an output buffer amplifier. Since there is no reference input pin, the power supply (V_{DD}) acts as the reference. Figure 1 shows a block diagram of the DAC architecture.

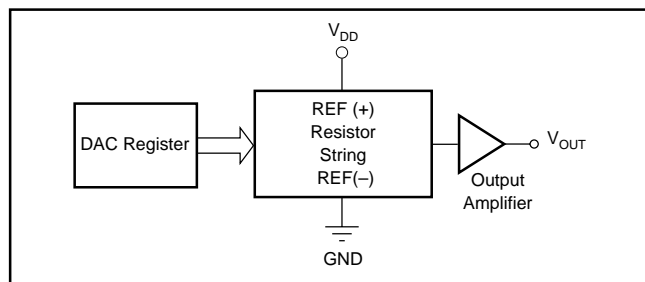

FIGURE 1. DAC7512 Architecture.

The input coding to the DAC7512 is straight binary, so the ideal output voltage is given by:

$$V_{OUT} = V_{DD} \cdot \frac{D}{4096}$$

where D = decimal equivalent of the binary code that is loaded to the DAC register; it can range from 0 to 4095.

RESISTOR STRING

The resistor string section is shown in Figure 2. It is simply a string of resistors, each of value R . The code loaded into the DAC register determines at which node on the string the voltage is tapped off to be fed into the output amplifier by closing one of the switches connecting the string to the amplifier. It is tested monotonic because it is a string of resistors.

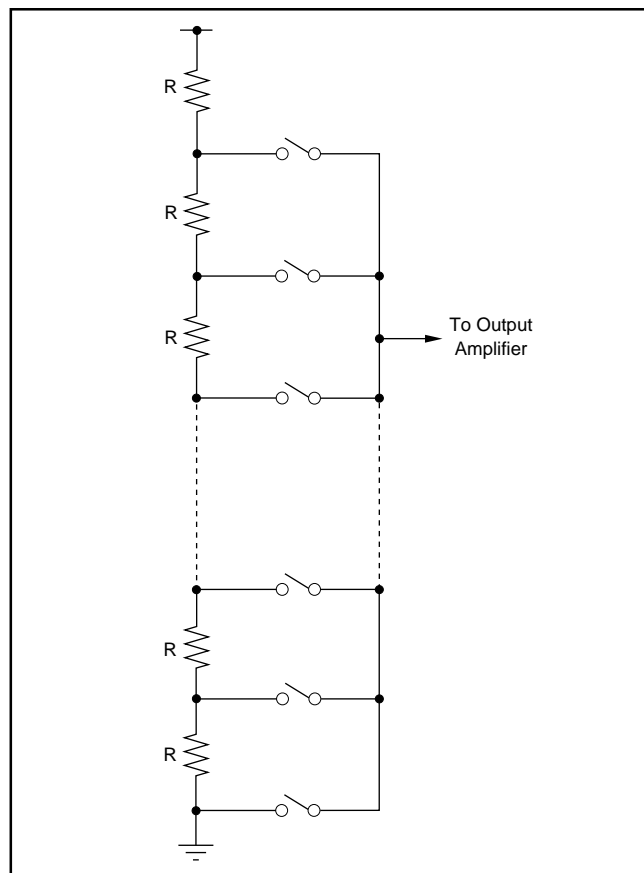

FIGURE 2. Resistor String.

OUTPUT AMPLIFIER

The output buffer amplifier is capable of generating rail-to-rail voltages on its output which gives an output range of 0V to V_{DD} . It is capable of driving a load of $2k\Omega$ in parallel with $100pF$ to GND. The source and sink capabilities of the output amplifier can be seen in the typical characteristics. The slew rate is $1V/\mu s$ with a half-scale settling time of $8\mu s$ with the output unloaded.

SERIAL INTERFACE

The DAC7512 has a three-wire serial interface ($\overline{\text{SYNC}}$, SCLK, and D_{IN}), which is compatible with SPI, QSPI, and Microwire interface standards as well as most Digital Signal Processors (DSPs). See the Serial Write Operation timing diagram for an example of a typical write sequence.

The write sequence begins by bringing the $\overline{\text{SYNC}}$ line LOW. Data from the D_{IN} line is clocked into the 16-bit shift register on the falling edge of SCLK. The serial clock frequency can be as high as 30MHz, making the DAC7512 compatible with high-speed DSPs. On the 16th falling edge of the serial clock, the last data bit is clocked in and the programmed function is executed (i.e., a change in DAC register contents and/or a change in the mode of operation).

At this point, the $\overline{\text{SYNC}}$ line may be kept LOW or brought HIGH. In either case, it must be brought HIGH for a minimum of 33ns before the next write sequence so that a falling edge of $\overline{\text{SYNC}}$ can initiate the next write sequence. Since the $\overline{\text{SYNC}}$ buffer draws more current when the $\overline{\text{SYNC}}$ signal is HIGH than it does when it is LOW, $\overline{\text{SYNC}}$ should be idled LOW between write sequences for lowest power operation of the part. As mentioned above, however, it must be brought HIGH again just before the next write sequence.

INPUT SHIFT REGISTER

The input shift register is 16 bits wide, as shown in Figure 3. The first two bits are “don’t cares”. The next two bits (PD1 and PD0) are control bits that control which mode of operation the part is in (normal mode or one of three power-down modes). There is a more complete description of the various modes in the Power-Down Modes section. The next 12 bits are the data bits. These are transferred to the DAC register on the 16th falling edge of SCLK.

$\overline{\text{SYNC}}$ INTERRUPT

In a normal write sequence, the $\overline{\text{SYNC}}$ line is kept LOW for at least 16 falling edges of SCLK and the DAC is updated on the 16th falling edge. However, if $\overline{\text{SYNC}}$ is brought HIGH before the 16th falling edge, this acts as an interrupt to the

write sequence. The shift register is reset and the write sequence is seen as invalid. Neither an update of the DAC register contents or a change in the operating mode occurs, as shown in Figure 4.

POWER-ON RESET

The DAC7512 contains a power-on reset circuit that controls the output voltage during power-up. On power-up, the DAC register is filled with zeros and the output voltage is 0V; it remains there until a valid write sequence is made to the DAC. This is useful in applications where it is important to know the state of the output of the DAC while it is in the process of powering up.

POWER-DOWN MODES

The DAC7512 contains four separate modes of operation. These modes are programmable by setting two bits (PD1 and PD0) in the control register. Table I shows how the state of the bits corresponds to the mode of operation of the device.

| DB13 | DB12 | OPERATING MODE |
|------|------|--|
| 0 | 0 | Normal Operation |
| 0 | 1 | Power-Down Modes: Output 1kΩ to GND |
| 1 | 0 | Output 100kΩ to GND |
| 1 | 1 | High-Z |

TABLE I. Modes of Operation for the DAC7512.

When both bits are set to 0, the part works normally with its normal power consumption of 135μA at 5V. However, for the three power-down modes, the supply current falls to 200nA at 5V (50nA at 3V). Not only does the supply current fall, but the output stage is also internally switched from the output of the amplifier to a resistor network of known values. This has the advantage that the output impedance of the part is known while the part is in power-down mode. There are three different options. The output is connected internally to GND through a 1kΩ resistor, a 100kΩ resistor, or it is left open-circuited (High-Z). See Figure 5 for the output stage.

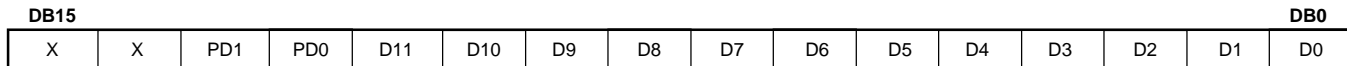

FIGURE 3. Data Input Register.

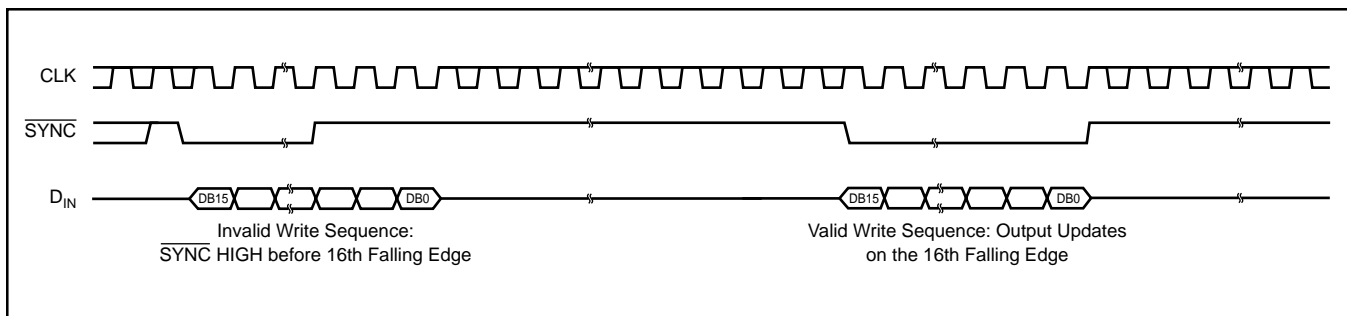

FIGURE 4. $\overline{\text{SYNC}}$ Interrupt Facility.

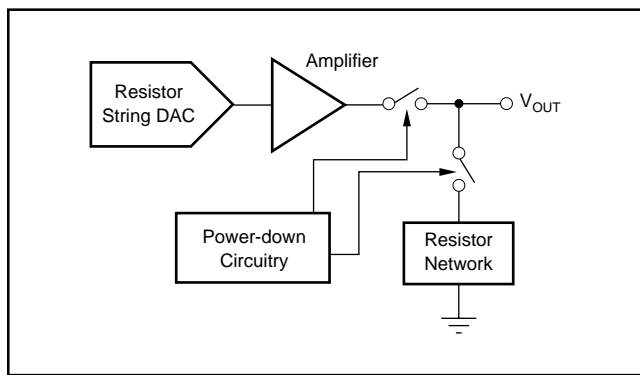

FIGURE 5. Output Stage During Power-Down.

All linear circuitry is shut down when the power-down mode is activated. However, the contents of the DAC register are unaffected when in power-down. The time to exit power-down is typically 2.5 μ s for $V_{DD} = 5V$ and 5 μ s for $V_{DD} = 3V$. See the Typical Characteristics for more information.

MICROPROCESSOR INTERFACING

DAC7512 TO 8051 INTERFACE

Figure 6 shows a serial interface between the DAC7512 and a typical 8051-type microcontroller. The setup for the interface is as follows: TXD of the 8051 drives SCLK of the DAC7512, while RXD drives the serial data line of the part. The $\overline{\text{SYNC}}$ signal is derived from a bit programmable pin on the port. In this case, port line P3.3 is used. When data is to be transmitted to the DAC7512, P3.3 is taken LOW. The 8051 transmits data only in 8-bit bytes; thus only eight falling clock edges occur in the transmit cycle. To load data to the DAC, P3.3 is left LOW after the first eight bits are transmitted, and a second write cycle is initiated to transmit the second byte of data. P3.3 is taken HIGH following the completion of this cycle. The 8051 outputs the serial data in a format which has the LSB first. The DAC7512 requires its data with the MSB as the first bit received. The 8051 transmit routine must therefore take this into account, and "mirror" the data as needed.

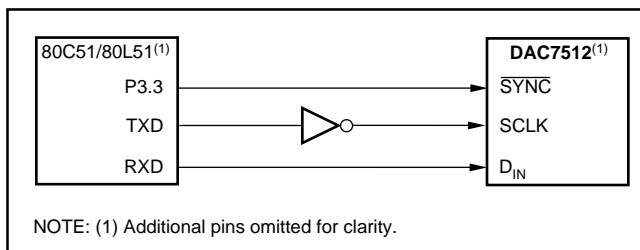

FIGURE 6. DAC7512 to 80C51/80L51 Interface.

DAC7512 TO MICROWIRE™ INTERFACE

Figure 7 shows an interface between the DAC7512 and any Microwire compatible device. Serial data is shifted out on the falling edge of the serial clock and is clocked into the DAC7512 on the rising edge of the SK signal.

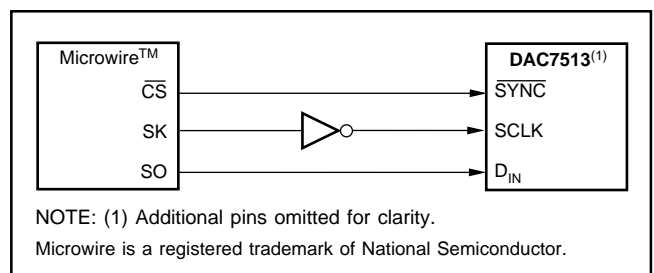

FIGURE 7. DAC7512 to Microwire Interface.

DAC7512 TO 68HC11 INTERFACE

Figure 8 shows a serial interface between the DAC7512 and the 68HC11 microcontroller. SCK of the 68HC11 drives the SCLK of the DAC7512, while the MOSI output drives the serial data line of the DAC. The $\overline{\text{SYNC}}$ signal is derived from a port line (PC7), similar to what was done for the 8051.

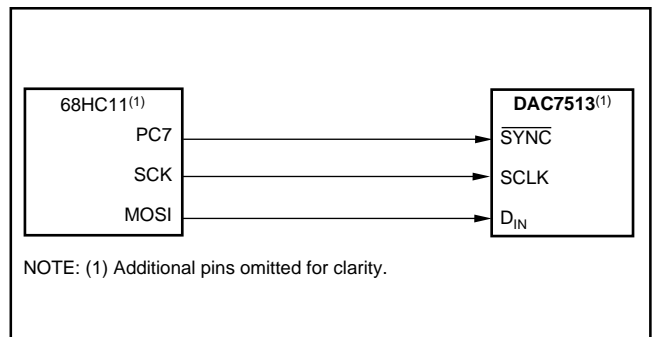

FIGURE 8. DAC7512 to 68HC11 Interface.

The 68HC11 should be configured so that its CPOL bit is a 0 and its CPHA bit is a 1. This configuration causes data appearing on the MOSI output is valid on the falling edge of SCK. When data is being transmitted to the DAC, the $\overline{\text{SYNC}}$ line is taken LOW (PC7). Serial data from the 68HC11 is transmitted in 8-bit bytes with only eight falling clock edges occurring in the transmit cycle. Data is transmitted MSB first. In order to load data to the DAC7512, PC7 is left LOW after the first eight bits are transferred, and a second serial write operation is performed to the DAC and PC7 is taken HIGH at the end of this procedure.

APPLICATIONS

USING REF02 AS A POWER SUPPLY FOR THE DAC7512

Due to the extremely low supply current required by the DAC7512, an alternative option is to use a REF02 +5V precision voltage reference to supply the required voltage to the part, see Figure 9. This is especially useful if the power supply is too noisy or if the system supply voltages are at some value other than 5V. The REF02 will output a steady supply voltage for the DAC7512. If the REF02 is used, the current it needs to supply to the DAC7512 is 135 μ A. This is with no load on the output of the DAC. When the DAC output

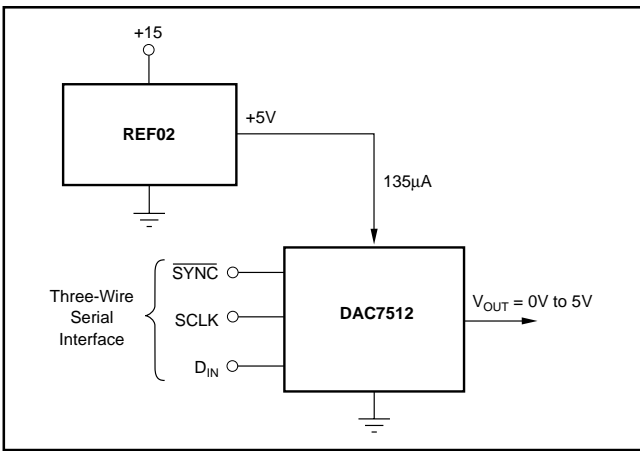

FIGURE 9. REF02 as Power Supply to DAC7512.

is loaded, the REF02 also needs to supply the current to the load. The total current required (with a 5kΩ load on the DAC output) is:

$$135\mu\text{A} + (5\text{V}/5\text{k}\Omega) = 1.14\text{mA}$$

The load regulation of the REF02 is typically 0.005%/mA, which results in an error of 285µV for the 1.14mA current drawn from it. This corresponds to a 0.2LSB error.

BIPOLAR OPERATION USING THE DAC7512

The DAC7512 has been designed for single-supply operation but a bipolar output range is also possible using the circuit in Figure 10. The circuit shown will give an output voltage range of ±5V. Rail-to-rail operation at the amplifier output is achievable using an OPA340 as the output amplifier.

The output voltage for any input code can be calculated as follows:

$$V_O = \left[V \cdot \left(\frac{D}{4096} \right) \cdot \left(\frac{R_1 + R_2}{R_1} \right) - V_{DD} \cdot \left(\frac{R_2}{R_1} \right) \right]$$

where D represents the input code in decimal (0 - 4095).

With $V_{DD} = 5\text{V}$, $R_1 = R_2 = 10\text{k}\Omega$:

$$V_O = \left(\frac{10 \cdot D}{4096} \right) - 5\text{V}$$

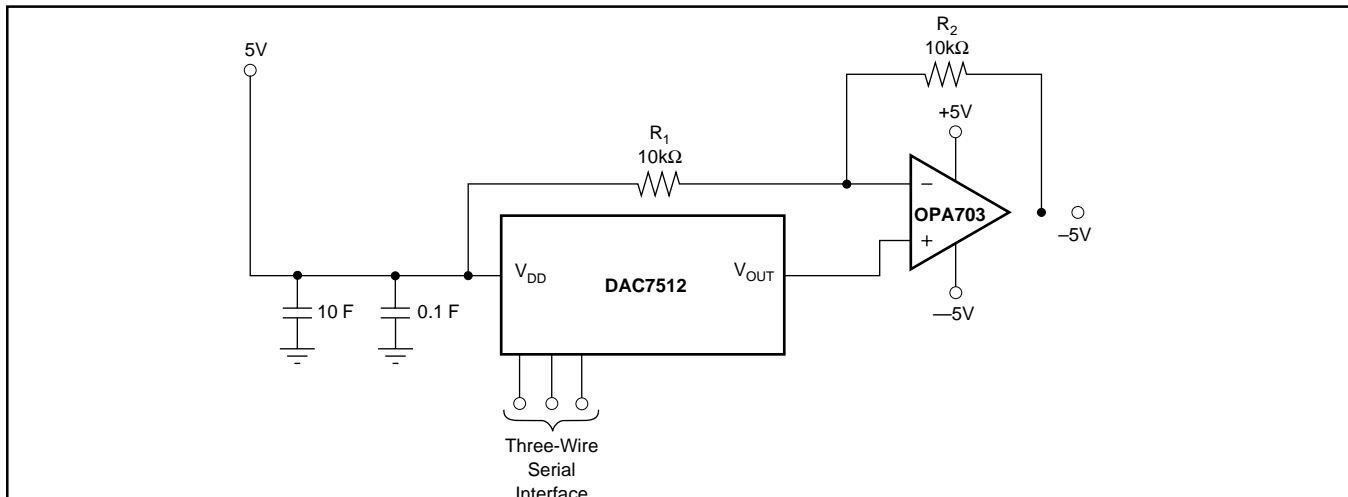

FIGURE 10. Bipolar Operation with the DAC7512.

This is an output voltage range of ±5V with 000_H corresponding to a -5V output and FFF_H corresponding to a +5V output.

LAYOUT

A precision analog component requires careful layout, adequate bypassing, and clean, well-regulated power supplies.

As the DAC7512 offers single-supply operation, it will often be used in close proximity with digital logic, microcontrollers, microprocessors, and digital signal processors. The more digital logic present in the design and the higher the switching speed, the more difficult it will be to achieve good performance from the converter.

Due to the single ground pin of the DAC7512, all return currents, including digital and analog return currents, must flow through the GND pin. Ideally, GND would be connected directly to an analog ground plane. This plane would be separate from the ground connection for the digital components until they were connected at the power entry point of the system.

The power applied to V_{DD} should be well regulated and low noise. Switching power supplies and DC/DC converters will often have high-frequency glitches or spikes riding on the output voltage. In addition, digital components can create similar high-frequency spikes as their internal logic switches states. This noise can easily couple into the DAC output voltage through various paths between the power connections and analog output. This is particularly true for the DAC7512, as the power supply is also the reference voltage for the DAC.

As with the GND connection, V_{DD} should be connected to a +5V power supply plane or trace that is separate from the connection for digital logic until they are connected at the power entry point. In addition, the 1µF to 10µF and 0.1µF bypass capacitors are strongly recommended. In some situations, additional bypassing may be required, such as a 100µF electrolytic capacitor or even a "Pi" filter made up of inductors and capacitors—all designed to essentially low-pass filter the +5V supply, removing the high-frequency noise.

DGK (R-PDSO-G8)

PLASTIC SMALL-OUTLINE PACKAGE

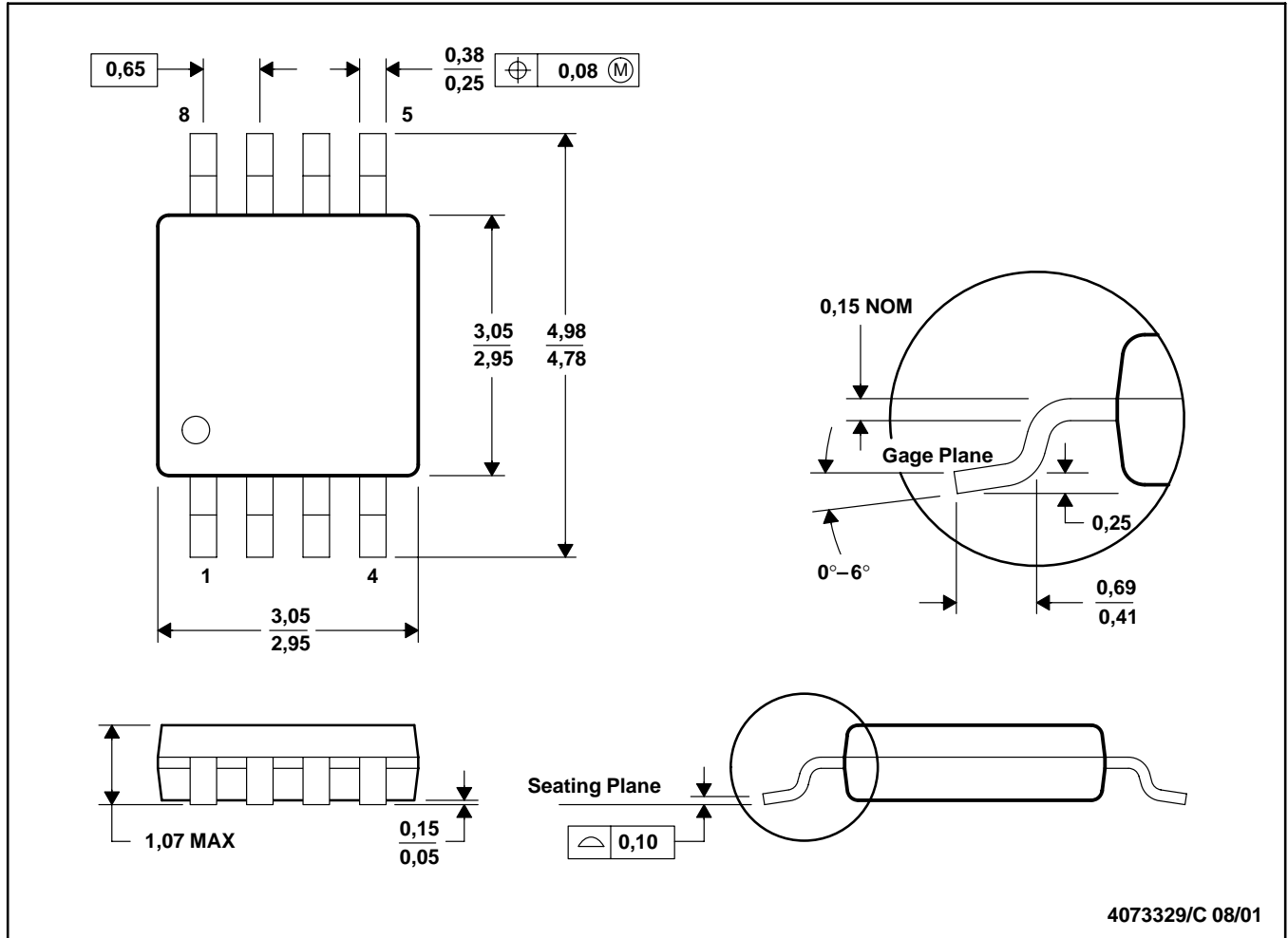

- NOTES: A. All linear dimensions are in millimeters.
 B. This drawing is subject to change without notice.
 C. Body dimensions do not include mold flash or protrusion.
 D. Falls within JEDEC MO-187

DBV (R-PDSO-G6)

PLASTIC SMALL-OUTLINE

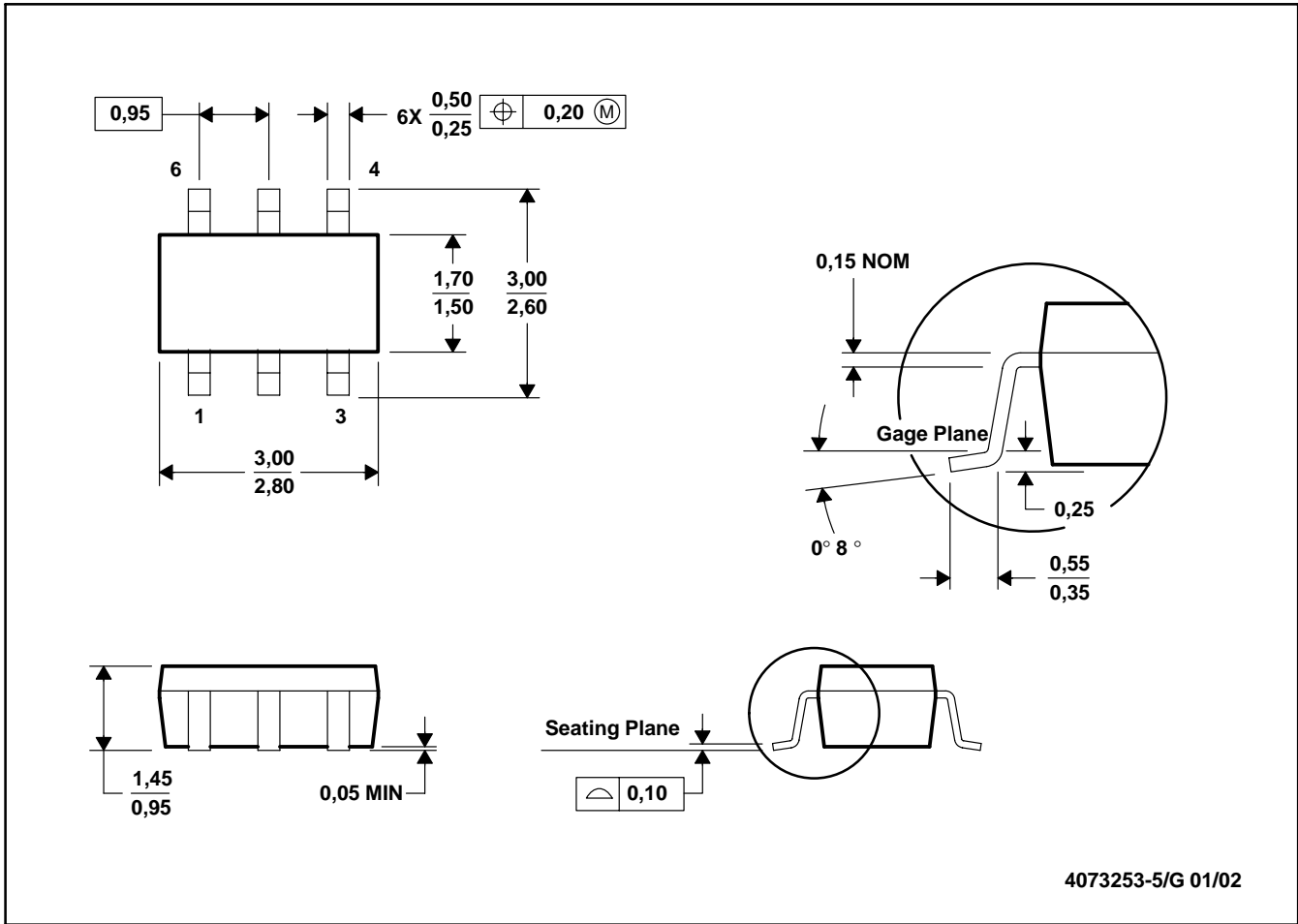

- NOTES: A. All linear dimensions are in millimeters.
 B. This drawing is subject to change without notice.
 C. Body dimensions do not include mold flash or protrusion.
 D. Leads 1, 2, 3 may be wider than leads 4, 5, 6 for package orientation.

PACKAGING INFORMATION

| Orderable Device | Status (1) | Package Type | Package Drawing | Pins | Package Qty | Eco Plan (2) | Lead finish/ Ball material (6) | MSL Peak Temp (3) | Op Temp (°C) | Device Marking (4/5) | Samples |
|------------------|---------------|--------------|-----------------|------|-------------|-----------------|--------------------------------------|----------------------|--------------|-------------------------|-------------------------|
| DAC7512E/250 | ACTIVE | VSSOP | DGK | 8 | 250 | RoHS & Green | Call TI NIPDAUAG | Level-2-260C-1 YEAR | -40 to 105 | D12E | Samples |
| DAC7512E/250G4 | ACTIVE | VSSOP | DGK | 8 | 250 | RoHS & Green | Call TI | Level-2-260C-1 YEAR | -40 to 105 | D12E | Samples |
| DAC7512E/2K5 | ACTIVE | VSSOP | DGK | 8 | 2500 | RoHS & Green | Call TI NIPDAUAG | Level-2-260C-1 YEAR | -40 to 105 | D12E | Samples |
| DAC7512N/250 | ACTIVE | SOT-23 | DBV | 6 | 250 | RoHS & Green | NIPDAU | Level-2-260C-1 YEAR | -40 to 105 | D12N | Samples |
| DAC7512N/250G4 | ACTIVE | SOT-23 | DBV | 6 | 250 | RoHS & Green | NIPDAU | Level-2-260C-1 YEAR | -40 to 105 | D12N | Samples |
| DAC7512N/3K | ACTIVE | SOT-23 | DBV | 6 | 3000 | RoHS & Green | NIPDAU | Level-2-260C-1 YEAR | -40 to 105 | D12N | Samples |
| DAC7512N/3KG4 | ACTIVE | SOT-23 | DBV | 6 | 3000 | RoHS & Green | NIPDAU | Level-2-260C-1 YEAR | -40 to 105 | D12N | Samples |

(1) The marketing status values are defined as follows:

ACTIVE: Product device recommended for new designs.

LIFEBUY: TI has announced that the device will be discontinued, and a lifetime-buy period is in effect.

NRND: Not recommended for new designs. Device is in production to support existing customers, but TI does not recommend using this part in a new design.

PREVIEW: Device has been announced but is not in production. Samples may or may not be available.

OBSOLETE: TI has discontinued the production of the device.

(2) **RoHS:** TI defines "RoHS" to mean semiconductor products that are compliant with the current EU RoHS requirements for all 10 RoHS substances, including the requirement that RoHS substance do not exceed 0.1% by weight in homogeneous materials. Where designed to be soldered at high temperatures, "RoHS" products are suitable for use in specified lead-free processes. TI may reference these types of products as "Pb-Free".

RoHS Exempt: TI defines "RoHS Exempt" to mean products that contain lead but are compliant with EU RoHS pursuant to a specific EU RoHS exemption.

Green: TI defines "Green" to mean the content of Chlorine (Cl) and Bromine (Br) based flame retardants meet JS709B low halogen requirements of <=1000ppm threshold. Antimony trioxide based flame retardants must also meet the <=1000ppm threshold requirement.

(3) MSL, Peak Temp. - The Moisture Sensitivity Level rating according to the JEDEC industry standard classifications, and peak solder temperature.

(4) There may be additional marking, which relates to the logo, the lot trace code information, or the environmental category on the device.

(5) Multiple Device Markings will be inside parentheses. Only one Device Marking contained in parentheses and separated by a "~" will appear on a device. If a line is indented then it is a continuation of the previous line and the two combined represent the entire Device Marking for that device.

⁽⁶⁾ Lead finish/Ball material - Orderable Devices may have multiple material finish options. Finish options are separated by a vertical ruled line. Lead finish/Ball material values may wrap to two lines if the finish value exceeds the maximum column width.

Important Information and Disclaimer:The information provided on this page represents TI's knowledge and belief as of the date that it is provided. TI bases its knowledge and belief on information provided by third parties, and makes no representation or warranty as to the accuracy of such information. Efforts are underway to better integrate information from third parties. TI has taken and continues to take reasonable steps to provide representative and accurate information but may not have conducted destructive testing or chemical analysis on incoming materials and chemicals. TI and TI suppliers consider certain information to be proprietary, and thus CAS numbers and other limited information may not be available for release.

In no event shall TI's liability arising out of such information exceed the total purchase price of the TI part(s) at issue in this document sold by TI to Customer on an annual basis.

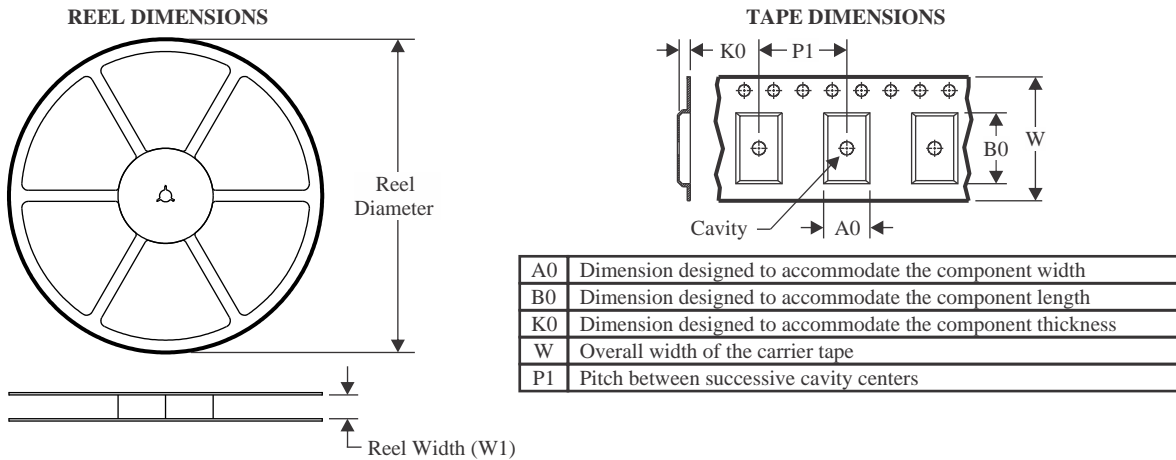
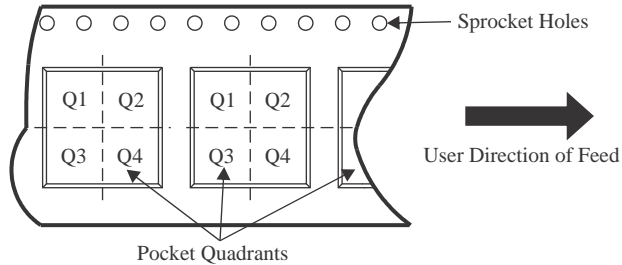
TAPE AND REEL INFORMATION

QUADRANT ASSIGNMENTS FOR PIN 1 ORIENTATION IN TAPE

*All dimensions are nominal

| Device | Package Type | Package Drawing | Pins | SPQ | Reel Diameter (mm) | Reel Width W1 (mm) | A0 (mm) | B0 (mm) | K0 (mm) | P1 (mm) | W (mm) | Pin1 Quadrant |
|--------------|--------------|-----------------|------|------|--------------------|--------------------|---------|---------|---------|---------|--------|---------------|
| DAC7512N/250 | SOT-23 | DBV | 6 | 250 | 178.0 | 9.0 | 3.23 | 3.17 | 1.37 | 4.0 | 8.0 | Q3 |
| DAC7512N/3K | SOT-23 | DBV | 6 | 3000 | 178.0 | 9.0 | 3.23 | 3.17 | 1.37 | 4.0 | 8.0 | Q3 |

TAPE AND REEL BOX DIMENSIONS

*All dimensions are nominal

| Device | Package Type | Package Drawing | Pins | SPQ | Length (mm) | Width (mm) | Height (mm) |
|--------------|--------------|-----------------|------|------|-------------|------------|-------------|
| DAC7512N/250 | SOT-23 | DBV | 6 | 250 | 180.0 | 180.0 | 18.0 |
| DAC7512N/3K | SOT-23 | DBV | 6 | 3000 | 180.0 | 180.0 | 18.0 |

EXAMPLE BOARD LAYOUT

DBV0006A

SOT-23 - 1.45 mm max height

SMALL OUTLINE TRANSISTOR

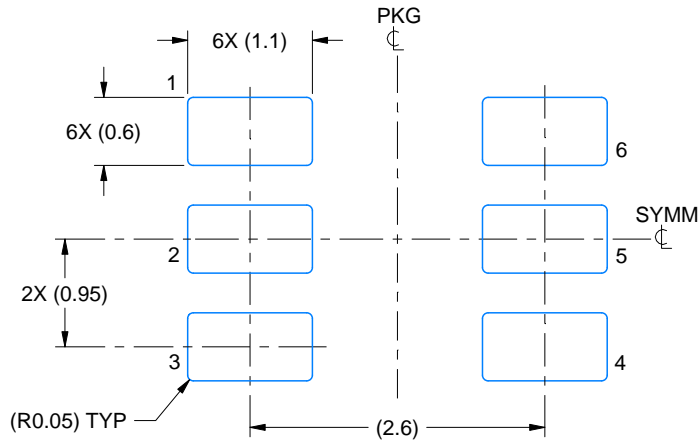

LAND PATTERN EXAMPLE
EXPOSED METAL SHOWN
SCALE:15X

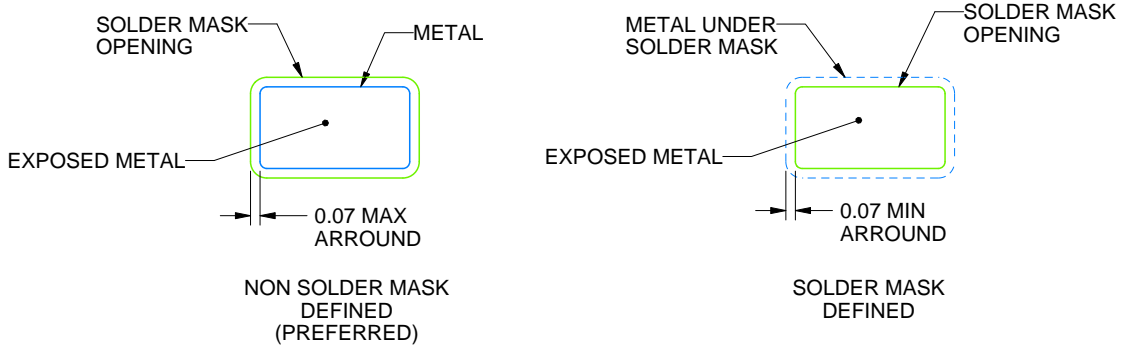

SOLDER MASK DETAILS

4214840/E 02/2024

NOTES: (continued)

- 6. Publication IPC-7351 may have alternate designs.
- 7. Solder mask tolerances between and around signal pads can vary based on board fabrication site.

EXAMPLE STENCIL DESIGN

DBV0006A

SOT-23 - 1.45 mm max height

SMALL OUTLINE TRANSISTOR

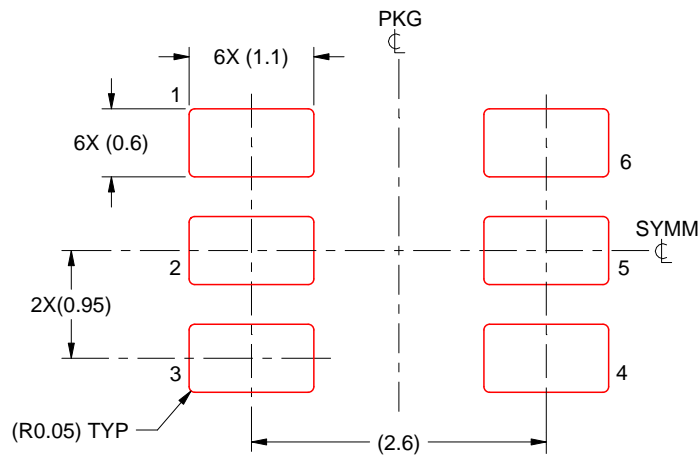

SOLDER PASTE EXAMPLE
BASED ON 0.125 mm THICK STENCIL
SCALE:15X

4214840/E 02/2024

NOTES: (continued)

8. Laser cutting apertures with trapezoidal walls and rounded corners may offer better paste release. IPC-7525 may have alternate design recommendations.
9. Board assembly site may have different recommendations for stencil design.

DGK0008A



PACKAGE OUTLINE

VSSOP - 1.1 mm max height

SMALL OUTLINE PACKAGE



4214862/A 04/2023

NOTES:

PowerPAD is a trademark of Texas Instruments.

1. All linear dimensions are in millimeters. Any dimensions in parenthesis are for reference only. Dimensioning and tolerancing per ASME Y14.5M.
2. This drawing is subject to change without notice.
3. This dimension does not include mold flash, protrusions, or gate burrs. Mold flash, protrusions, or gate burrs shall not exceed 0.15 mm per side.
4. This dimension does not include interlead flash. Interlead flash shall not exceed 0.25 mm per side.
5. Reference JEDEC registration MO-187.

EXAMPLE BOARD LAYOUT

DGK0008A

™ VSSOP - 1.1 mm max height

SMALL OUTLINE PACKAGE



LAND PATTERN EXAMPLE
EXPOSED METAL SHOWN
SCALE: 15X



SOLDER MASK DETAILS

4214862/A 04/2023

NOTES: (continued)

6. Publication IPC-7351 may have alternate designs.
7. Solder mask tolerances between and around signal pads can vary based on board fabrication site.
8. Vias are optional depending on application, refer to device data sheet. If any vias are implemented, refer to their locations shown on this view. It is recommended that vias under paste be filled, plugged or tented.
9. Size of metal pad may vary due to creepage requirement.

EXAMPLE STENCIL DESIGN

DGK0008A

TM VSSOP - 1.1 mm max height

SMALL OUTLINE PACKAGE



SOLDER PASTE EXAMPLE
SCALE: 15X

4214862/A 04/2023

NOTES: (continued)

11. Laser cutting apertures with trapezoidal walls and rounded corners may offer better paste release. IPC-7525 may have alternate design recommendations.
12. Board assembly site may have different recommendations for stencil design.

IMPORTANT NOTICE AND DISCLAIMER

TI PROVIDES TECHNICAL AND RELIABILITY DATA (INCLUDING DATA SHEETS), DESIGN RESOURCES (INCLUDING REFERENCE DESIGNS), APPLICATION OR OTHER DESIGN ADVICE, WEB TOOLS, SAFETY INFORMATION, AND OTHER RESOURCES "AS IS" AND WITH ALL FAULTS, AND DISCLAIMS ALL WARRANTIES, EXPRESS AND IMPLIED, INCLUDING WITHOUT LIMITATION ANY IMPLIED WARRANTIES OF MERCHANTABILITY, FITNESS FOR A PARTICULAR PURPOSE OR NON-INFRINGEMENT OF THIRD PARTY INTELLECTUAL PROPERTY RIGHTS.

These resources are intended for skilled developers designing with TI products. You are solely responsible for (1) selecting the appropriate TI products for your application, (2) designing, validating and testing your application, and (3) ensuring your application meets applicable standards, and any other safety, security, regulatory or other requirements.

These resources are subject to change without notice. TI grants you permission to use these resources only for development of an application that uses the TI products described in the resource. Other reproduction and display of these resources is prohibited. No license is granted to any other TI intellectual property right or to any third party intellectual property right. TI disclaims responsibility for, and you will fully indemnify TI and its representatives against, any claims, damages, costs, losses, and liabilities arising out of your use of these resources.

TI's products are provided subject to [TI's Terms of Sale](#) or other applicable terms available either on [ti.com](https://www.ti.com) or provided in conjunction with such TI products. TI's provision of these resources does not expand or otherwise alter TI's applicable warranties or warranty disclaimers for TI products.

TI objects to and rejects any additional or different terms you may have proposed.

Mailing Address: Texas Instruments, Post Office Box 655303, Dallas, Texas 75265
Copyright © 2024, Texas Instruments Incorporated

Looking for pricing, stock, or lifecycle information?

Click below to explore more details on WIN SOURCE:

 [View DAC7512E/2K5 on WIN SOURCE](#)

 [Texas Instruments](#) Information

Optimize Your Supply Chain with WIN SOURCE Solutions

-  Global Sourcing Solution
-  Obsolete Management
-  Cost Control Management
-  Shortage Management
-  Alternative Solution
-  Excess Inventory Management