



**THE DATASHEET OF
SF1186B-3**



- **Designed for GPS RF Front-end Applications**
- **Low Insertion Loss**
- **3.0 x 3.0 x 1.3 mm Surface-mount Case**
- **No Matching Circuit Required**
- **Complies with Directive 2002/95/EC (RoHS)**
- **Moisture Sensitivity Level: 1**
- **AEC-Q200 Qualified**

SF1186B-3

**1575.42 MHz
SAW Filter**

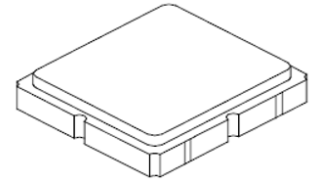

SM3030-6

Maximum Ratings at +25 °C Unless Stated Otherwise

Rating	Symbol	Value	Units
Maximum Input Signal Level		+10	dBm
Maximum DC Voltage	WVdc	4	Volts
Operating Temperature Range	T _A	-40 to +85	°C
Storage Temperature Range	T _{STG}	-40 to +105	°C
Reflow Soldering Temperature, 10 Seconds	T _{Reflow10}	260	°C
Reflow Soldering Temperature, 40 Seconds	T _{Reflow40}	235	°C

Characteristic	Sym	Notes	Min	Typ	Max	Units	
Center Frequency	f _C			1575.42		MHz	
1 dB Bandwidth			10	18		MHz	
VSWR, f _C ±2.0 MHz				1.4:1	2.0:1		
Insertion Loss				2.68	3.5	dB	
Attenuation Referenced to 0 dB:							
850 MHz			45	51.2		dB	
1500 MHz			40	52.7			
1535.42 MHz			20	38.9			
1615.42 MHz			20	58.8			
1640 MHz			45	59.1			
1700 MHz			50	56.7			
Temperature Coefficient			-30			ppm/°C	
Operating Temperature	T _A		-40		+85	°C	
Single Ended Input / Output, Impedance match	No matching network required for operation at 50 ohms						
Case Style	SM3030-6 3 x 3 mm Nominal Footprint						
Lid Symbolization	Y=year, WW=week, S=shift					598	YWWS

Electrical Connections

Pin #	Description	Pin #	Description
1	Ground	4	Ground
2	Input	5	Output
3	Ground	6	Ground

 **CAUTION: Electrostatic Sensitive Device. Observe precautions for handling.**
NOTES:

1. The design, manufacturing process, and specifications of this device are subject to change.
2. US or International patents may apply.
3. RoHS compliant from the first date of manufacture.

25 Jul 2005 11:14:38

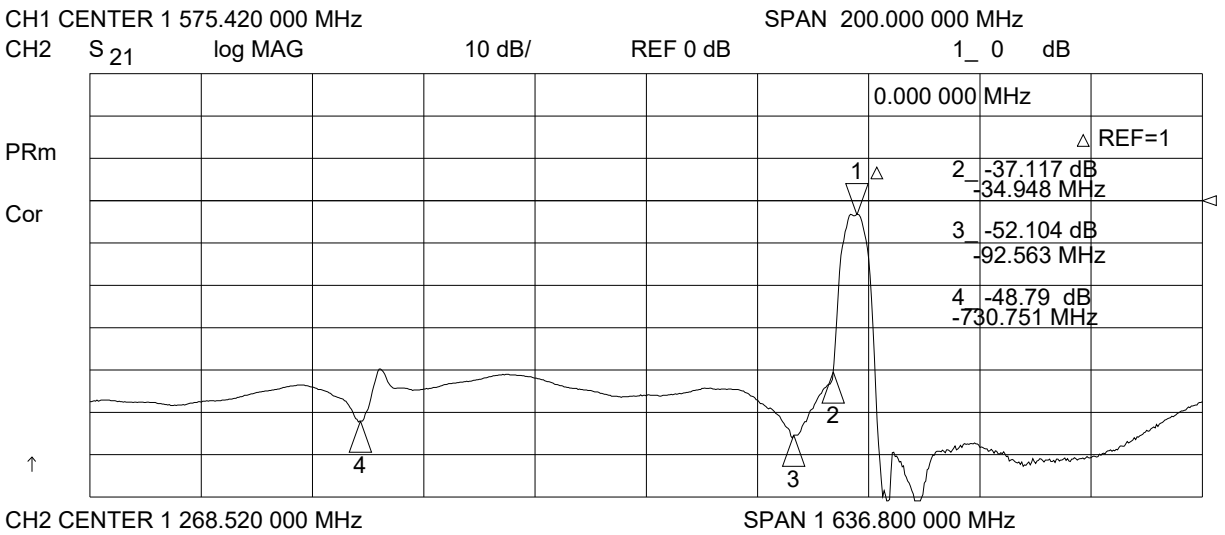
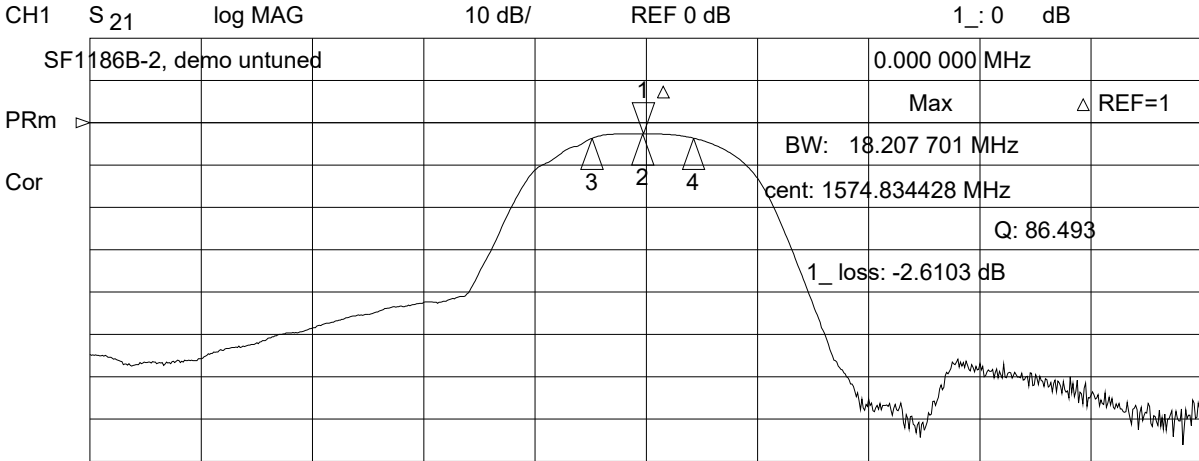

CH1 S₁₁ 1 UFS
[h]

25 Jul 2005 11:15:25
1_ 34.395 Ω 3.5762 Ω 361.28 pH

PRm
Cor

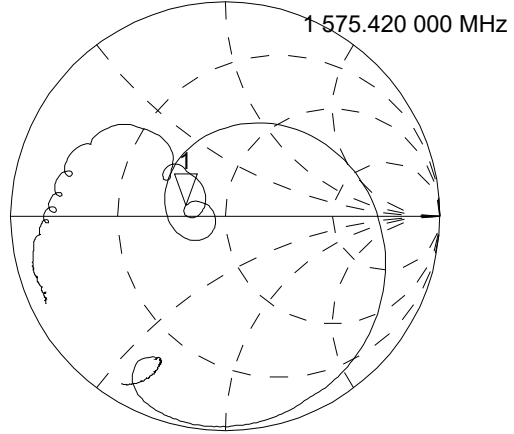

↑

CH2 S₂₂ 1 UFS
SF1186B-2, demo untuned

1_ : 34.543 Ω 2.1738 Ω 219.61 pH

PRm
Cor

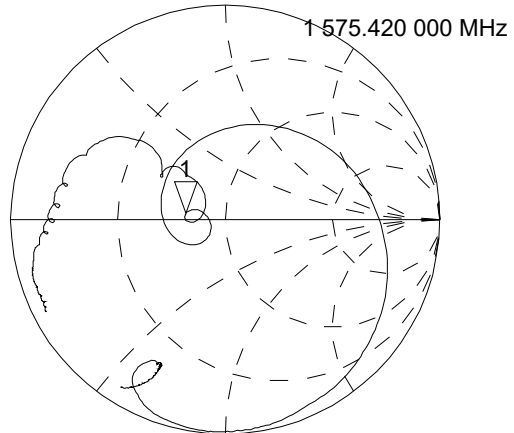

↑

CENTER 1 575.420 000 MHz

SPAN 200.000 000 MHz

Tape and Reel Specifications

Tape and Reel Standard per ANSI/EIA-481

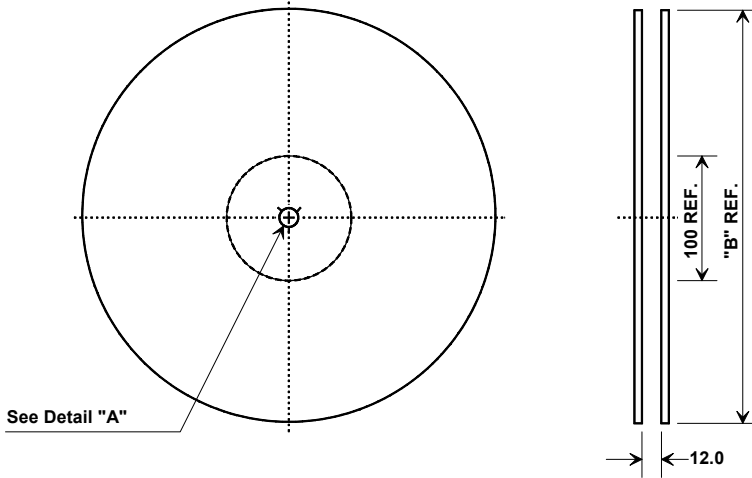

"B" Nominal Size		Quantity Per Reel
Inches	millimeters	
7	178	500
13	330	3000

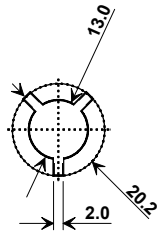

COMPONENT ORIENTATION

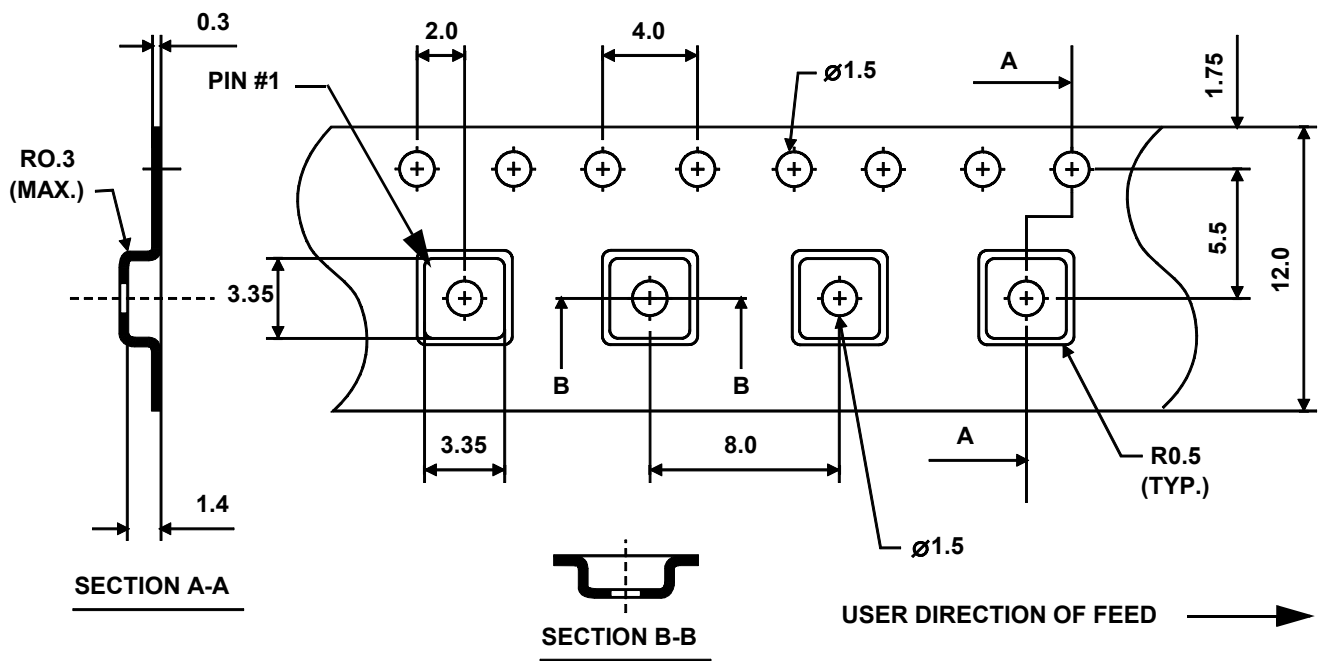

SM3030-6 Case

6-Terminal Ceramic Surface-Mount Case 3.0 X 3.0 mm Nominal Footprint

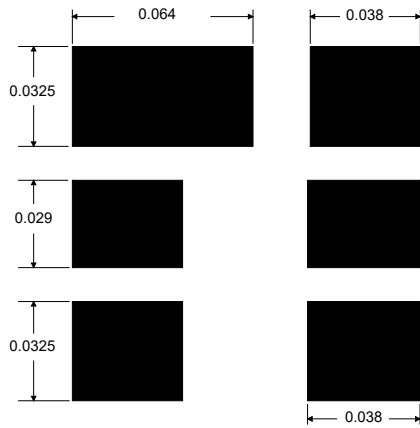
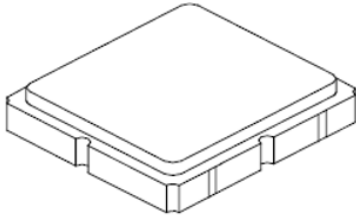

Foot Print Dimensions in Inches

Case Dimensions						
Dimension	mm			Inches		
	Min	Nom	Max	Min	Nom	Max
A	2.87	3.0	3.13	0.113	0.118	0.123
B	2.87	3.0	3.13	0.113	0.118	0.123
C	1.12	1.25	1.38	0.044	0.049	0.054
D	0.77	0.9	1.03	0.030	0.035	0.040
E	2.67	2.80	2.93	0.105	0.110	0.115
F	1.47	1.6	1.73	0.058	0.063	0.068
G	0.72	0.85	0.98	0.028	0.033	0.038
H	1.37	1.5	1.63	0.054	0.059	0.064
I	0.47	0.6	0.73	0.019	0.024	0.029
J	1.17	1.3	1.43	0.046	0.051	0.056

Electrical Connections		
Connection	Terminals	
Port 1	Single-ended Input	2
Port 2	Single-ended Output	5
	Ground	All others
Single-ended Operation Only		
Dot indicates Pin 1		

Case Materials	
Solder Pad Plating	0.3 to 1.0 μm Gold over 1.27 to 8.89 μm Nickel
Lid Plating	2.0 to 3.0 μm Nickel
Body	Al_2O_3 Ceramic

TOP VIEW

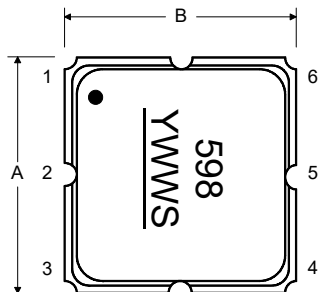

BOTTOM VIEW

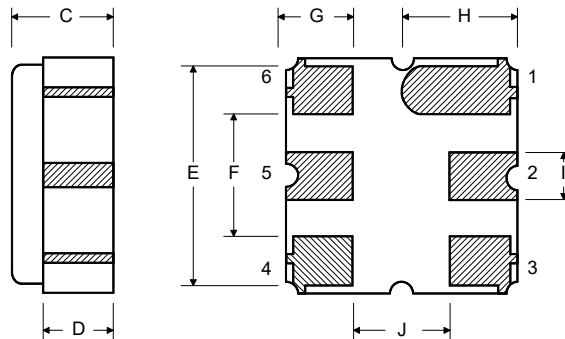

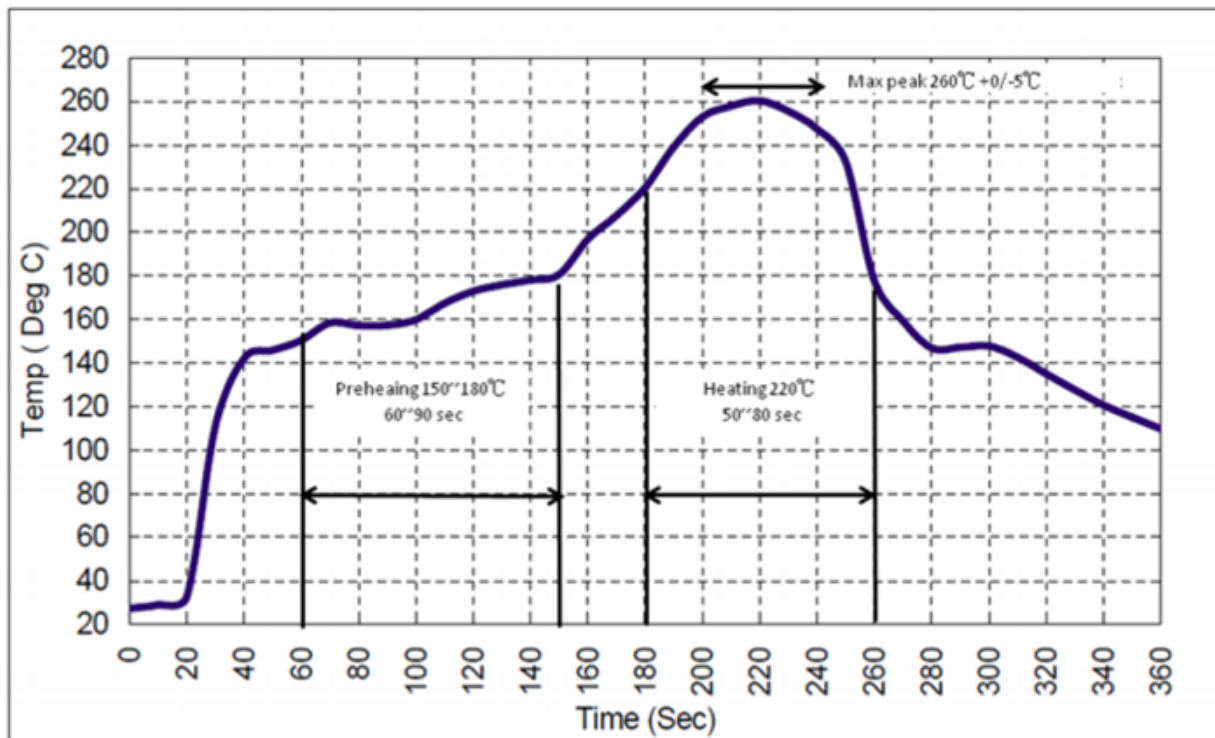

Recommended Reflow Profile

1. Preheating shall be fixed at 150~180°C for 60~90 seconds.
2. Ascending time to preheating temperature 150°C shall be 30 seconds min.
3. Heating shall be fixed at 220°C for 50~80 seconds and at 260°C+0/-5°C peak (10 seconds).
4. Time: 5 times maximum.



Looking for pricing, stock, or lifecycle information?

Click below to explore more details on WIN SOURCE:

-  [View SF1186B-3 on WIN SOURCE](#)
-  [RF Monolithics, Inc Information](#)

Optimize Your Supply Chain with WIN SOURCE Solutions

-  Global Sourcing Solution
-  Obsolete Management
-  Cost Control Management
-  Shortage Management
-  Alternative Solution
-  Excess Inventory Management