



**THE DATASHEET OF  
SF2250E-1**



# SF2250E-1

## 1615 MHz SAW Filter

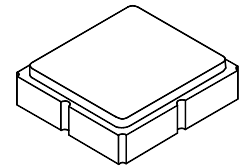

SM3030-6

- Low-loss SAW Filter, 1615 MHz, 20 MHz Bandwidth
- 3.0 x 3.0 x 1.4 mm Surface-mount Case
- 50  $\Omega$  Input/Output Impedance
- Complies with Directive 2002/95/EC (RoHS)
- Moisture Sensitivity Level: 1

### Absolute Maximum Ratings

Rating	Value	Units
Incident Power in Passband	+24	dBm
DC Voltage on any Non-ground Terminal	3	VDC
Operating Temperature Range	-20 to +70	$^{\circ}$ C
Storage Temperature Range in Tape and Reel	-40 to +85	$^{\circ}$ C
Maximum Soldering Profile, 5 cycles/10 seconds maximum	265	$^{\circ}$ C

### Electrical Characteristics

Characteristic	Sym	Notes	Min	Typ	Max	Units
Center Frequency	$f_c$			1615		MHz
Insertion Loss, 1605 to 1625 MHz	IL			3.4	4.6	dB
Amplitude Ripple, p-p, 1605 to 1625 MHz				0.3	2.0	
Attenuation Referenced to 0 dB						dB
1100 to 1400 MHz			40	55		
1400 to 1550 MHz			33	52		
1700 to 1825 MHz			30	52		
1825 to 1900 MHz			36	52		
Terminating Source impedance	$Z_s$			50		$\Omega$
Terminating Load impedance	$Z_L$			50		$\Omega$
Input/Output Impedance Match	No matching network required for 50 ohm source/load					
Case Style	SM3030-6					
Lid Symbolization: Y = year, WW = week, S = shift	5M, <u>YWWS</u>					



**CAUTION: Electrostatic Sensitive Device. Observe precautions for handling.**

#### NOTES:

1. The design, manufacturing process, and specifications of this device are subject to change.
2. US or International patents may apply.
3. RoHS compliant from the first date of manufacture.

## Matching Circuit

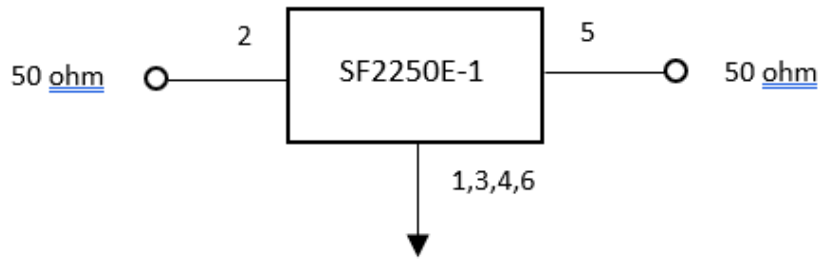

## Frequency Response Plots

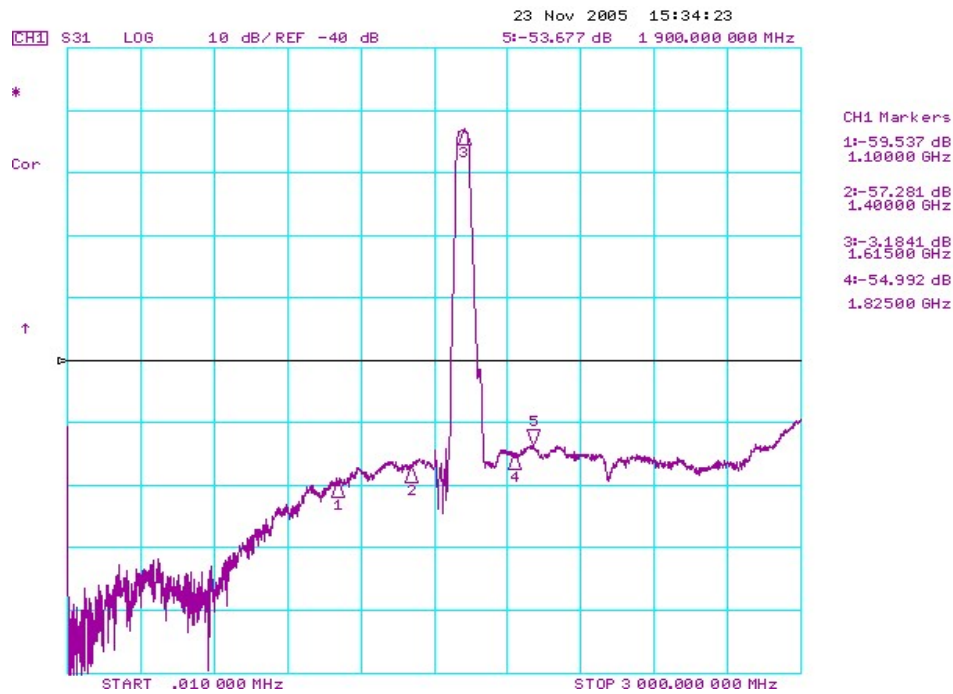

## 6-Terminal Ceramic Surface-Mount Case 3.0 X 3.0 mm Nominal Footprint

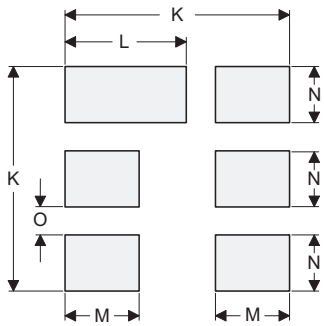
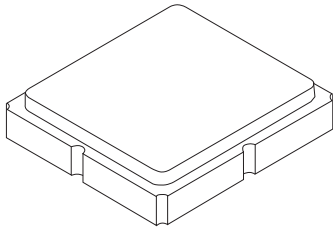

**PCB Footprint Top View**

### Case and PCB Footprint Dimensions

Dimension	mm			Inches		
	Min	Nom	Max	Min	Nom	Max
<b>A</b>	2.87	3.00	3.13	0.113	0.118	0.123
<b>B</b>	2.87	3.00	3.13	0.113	0.118	0.123
<b>C</b>	1.12	1.25	1.38	0.044	0.049	0.054
<b>D</b>	0.77	0.90	1.03	0.030	0.035	0.040
<b>E</b>	2.67	2.80	2.93	0.105	0.110	0.115
<b>F</b>	1.47	1.60	1.73	0.058	0.063	0.068
<b>G</b>	0.72	0.85	0.98	0.028	0.033	0.038
<b>H</b>	1.37	1.50	1.63	0.054	0.059	0.064
<b>I</b>	0.47	0.60	0.73	0.019	0.024	0.029
<b>J</b>	1.17	1.30	1.43	0.046	0.051	0.056
<b>K</b>		3.20			0.126	
<b>L</b>		1.70			0.067	
<b>M</b>		1.05			0.041	
<b>N</b>		0.81			0.032	
<b>O</b>		0.38			0.015	

### Case Materials

Materials	
Solder Pad Plating	0.3 to 1.0 $\mu$ m Gold over 1.27 to 8.89 $\mu$ m Nickel
Lid Plating	2.0 to 3.0 $\mu$ m Nickel
Body	Al <sub>2</sub> O <sub>3</sub> Ceramic

### TOP VIEW

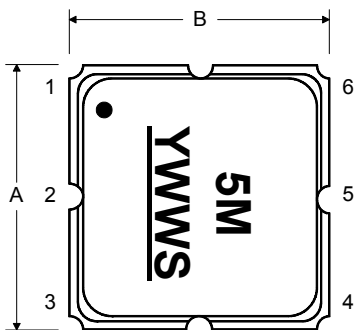

### BOTTOM VIEW

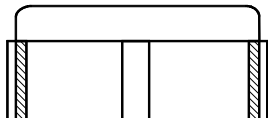
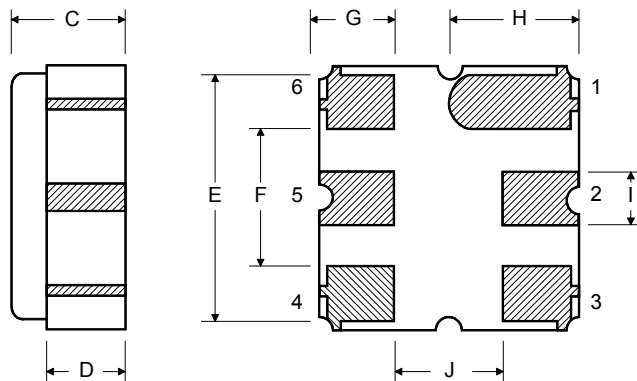



## Recommended Reflow Profile

1. Preheating shall be fixed at 150~180°C for 60~90 seconds.
2. Ascending time to preheating temperature 150°C shall be 30 seconds min.
3. Heating shall be fixed at 220°C for 50~80 seconds and at 260°C +0/-5°C peak (10 seconds).
4. Time: 5 times maximum.



## Looking for pricing, stock, or lifecycle information?

Click below to explore more details on WIN SOURCE:

 [View SF2250E-1 on WIN SOURCE](#)

 [RF Monolithics, Inc Information](#)

## Optimize Your Supply Chain with WIN SOURCE Solutions

-  Global Sourcing Solution
-  Obsolete Management
-  Cost Control Management
-  Shortage Management
-  Alternative Solution
-  Excess Inventory Management