



THE DATASHEET OF SF2170D



- **Low Insertion Loss**
- **3.8 X 3.8 X 1.0 mm Surface Mount Case**
- **Single-Ended Input/Output**
- **Complies with Directive 2002/95/EC (RoHS)**
- **Moisture Sensitivity Level: 1**

Absolute Maximum Ratings

Rating	Value	Units
Maximum Incident Power in Passband	+10	dBm
Maximum DC Voltage Between any 2 Terminals	30	VDC
Storage Temperature Range in Tape and Reel	-40 to +85	°C
Suitable for Lead-free Soldering - Maximum Soldering Profile	260°C for 30 s	

SF2170D

**165 MHz
SAW Filter**

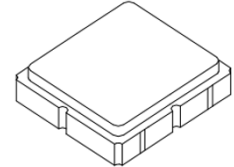

SM3838-6

Electrical Characteristics

Characteristic	Sym	Notes	Min	Typ	Max	Units
Center Frequency	f_c			165		MHz
Source Impedance to Matching Network (single ended)				50		Ω
Load Impedance to Matching Network (single ended)				50		Ω
Passband Width			20	22		MHz
Rejection Referenced to Minimum Insertion Loss:						dB
10 MHz to 110 MHz			35	40		
127 MHz to 149 MHz			10	15		
190 to 210 MHz			30	40		
210 to 450 MHz			40	45		
Maximum Insertion Loss				9	10	dB
Insertion Loss Variation over -40 to 85 °C					1	dB
Amplitude Variation over 20 MHz Passband				1.0	1.5	dB _{p,p}
Group Delay Variation over 20 MHz Passband				40	80	ns _{p,p}
Absolute Group Delay at f_c				0.33		μ s
Input/Output Return Loss into Matching over 20 MHz BW			6	8		dB
Operating Temperature			-40		+85	°C

Case Style	SM3838-6 3.8 x 3.8 mm Nominal Footprint
Lid Symbolization (Y=year, WW=week, S=shift) dot=pin 1 indicator	865, <u>YWWS</u>



CAUTION: Electrostatic Sensitive Device. Observe precautions for handling.

NOTES:

1. The design, manufacturing process, and specifications of this device are subject to change.
2. US or International patents may apply.
3. RoHS compliant from the first date of manufacture.

Broadband Filter Response and Return Loss (through matching network)

17 Sep 2008 06:49:06

CH1 LOG 5 dB/ REF 0 dB
S11 3 : 5.2056 dB 20 .000 000 MHz

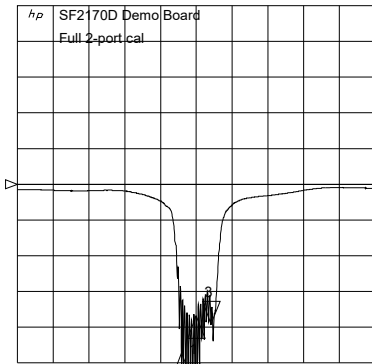

CH1 Markers
Δ REF=2
mean : -20 .948 dB
s. dev : 5.2747 dB
p-p : 29.591 dB

CH3 LOG 5 dB/ REF 0 dB
S22 3 : -3 .5658 dB 20 .000 000 MHz

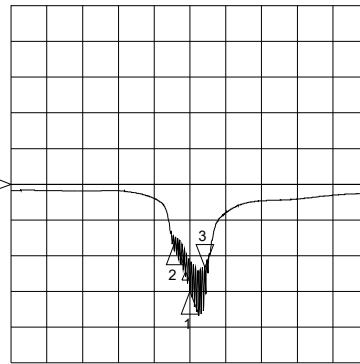

CH3 Markers
Δ REF=2
mean : -12 .005 dB
s. dev : 2.7750 dB
p-p : 11.003 dB

CENTR 165 .000 MHz SPAN 240 .000 MHz

CENTR 165 .000 MHz SPAN 240 .000 MHz

CH2 S21 LOG 10 dB/ REF -55 dB 1 : -9 .8909 dB 158 .700 000 MHz

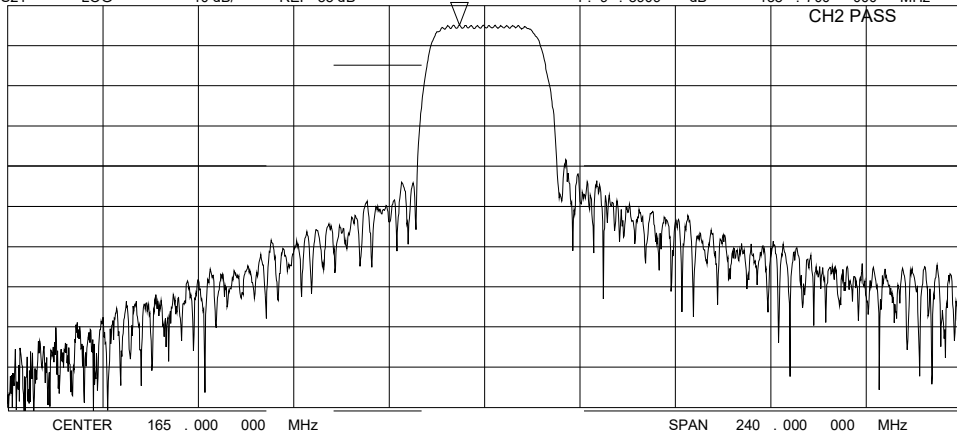

Max

↑

CENTR 165 .000 000 MHz

SPAN 240 .000 000 MHz

Passband Amplitude and Impedance Detail

17 Sep 2008 14:04:20

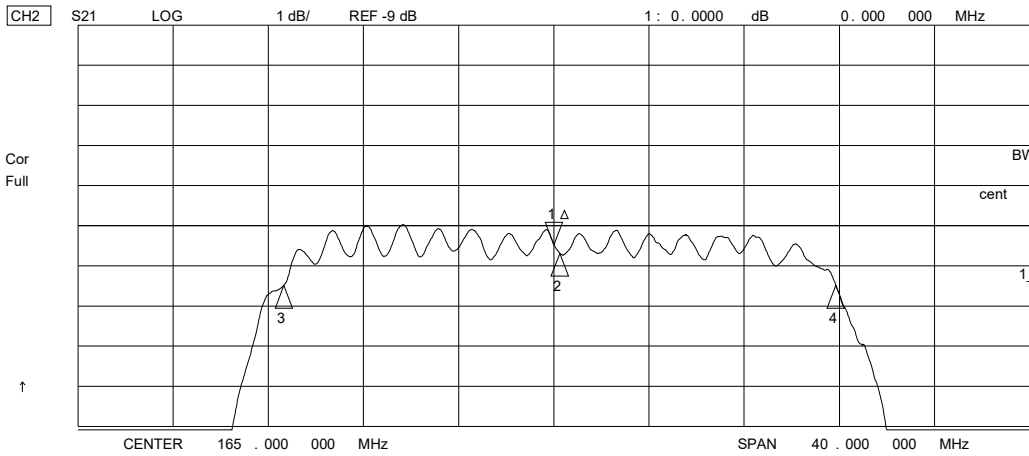
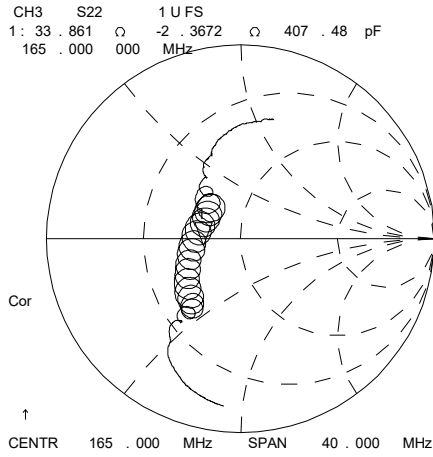
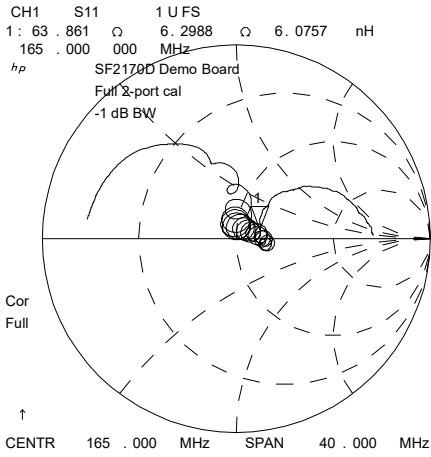

CH2 Markers
 Δ REF=1
 BW: 23 . 196777 MHz
 cent : 165 . 256979 MHz
 Q: 7 . 1241
 1 loss : -9 . 4834 dB

Passband Group Delay and Amplitude Ripple

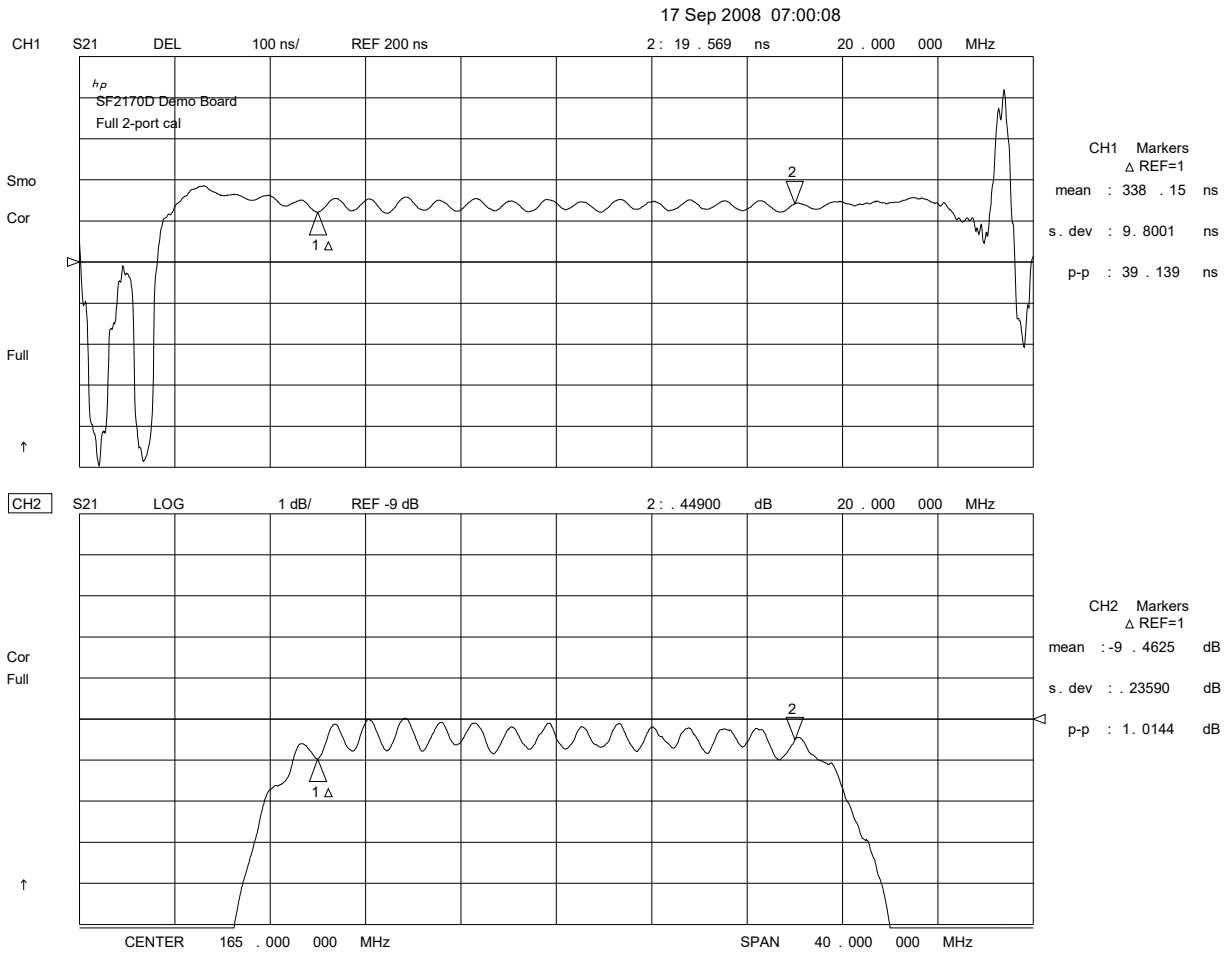

SF2170D Demo Circuit

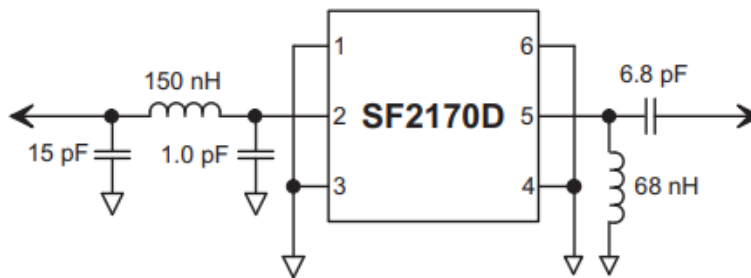

Tape and Reel Specifications

Tape and Reel Standard per ANSI/EIA-481

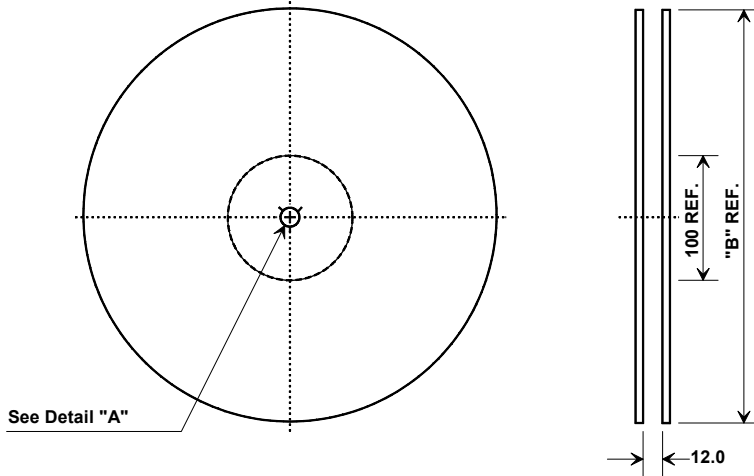

"B"		Quantity Per Reel
Inches	millimeters	
7	178	500
13	330	2000

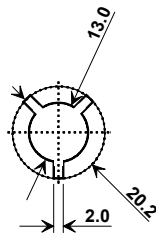

COMPONENT ORIENTATION and DIMENSIONS

Carrier Tape Dimensions	
Ao	4.25 mm
Bo	4.25 mm
Ko	1.30 mm
Pitch	8.0 mm
W	12.0 mm

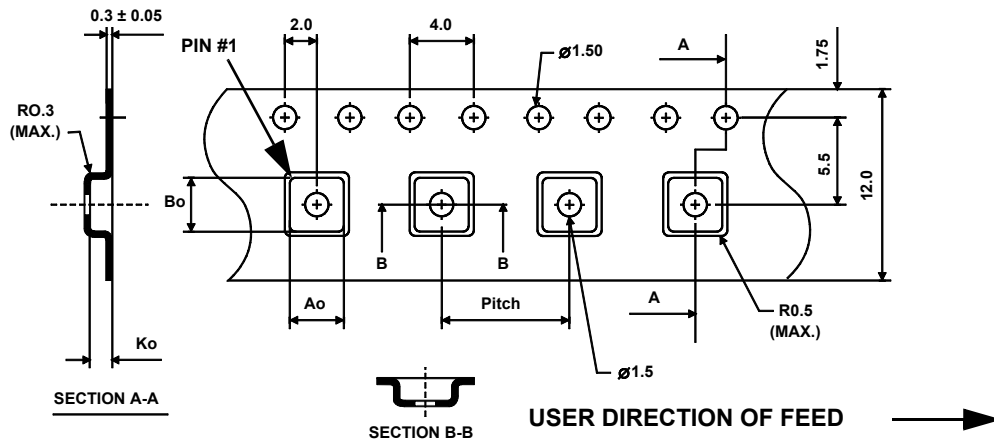

SM3838-6 Case

6-Terminal Ceramic Surface-Mount Case

3.8 X 3.8 mm Nominal Footprint

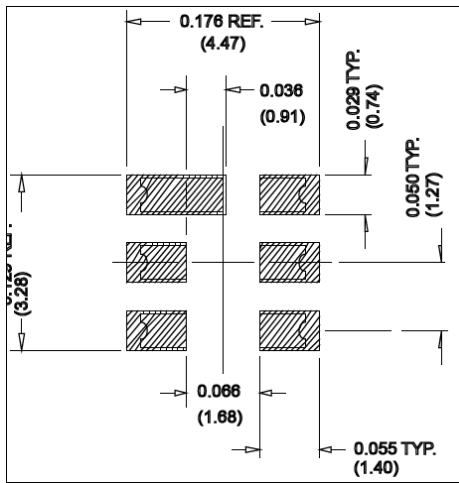
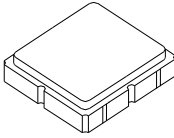

PCB Footprint

Case Dimensions						
Dimension	mm			Inches		
	Min	Nom	Max	Min	Nom	Max
A	3.60	3.80	4.0	0.14	0.15	0.16
B	3.60	3.80	4.0	0.14	0.15	0.16
C	1.30	1.50	1.70	0.05	0.06	0.067
D	0.95	1.10	1.25	0.037	0.043	0.05
E	2.39	2.54	2.69	0.090	0.10	0.110
G	0.90	1.0	1.10	0.035	0.04	0.043
H	1.90	2.0	2.10	0.75	0.08	0.83
I	0.50	0.6	0.70	0.020	0.024	0.028
J	1.70	1.8	1.90	0.067	0.07	0.075

Electrical Connections		
Connection	Terminals	
Port 1	Single-ended Input	2
Port 2	Single-ended Output	5
	Ground	All others

Single Ended Operation Only

Dot indicates Pin 1

Materials	
Solder Pad Plating	0.3 to 1.0 μm Gold over 1.27 to 8.89 μm Nickel
Lid Plating	2.0 to 3.0 μm Nickel
Body	Al_2O_3 Ceramic

TOP VIEW

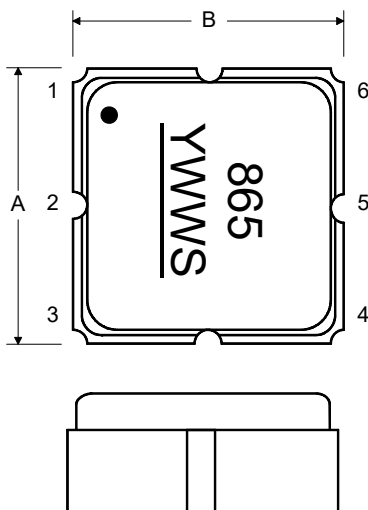

BOTTOM VIEW

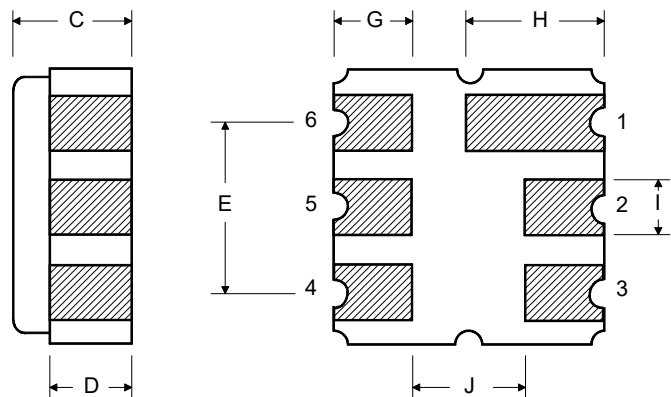

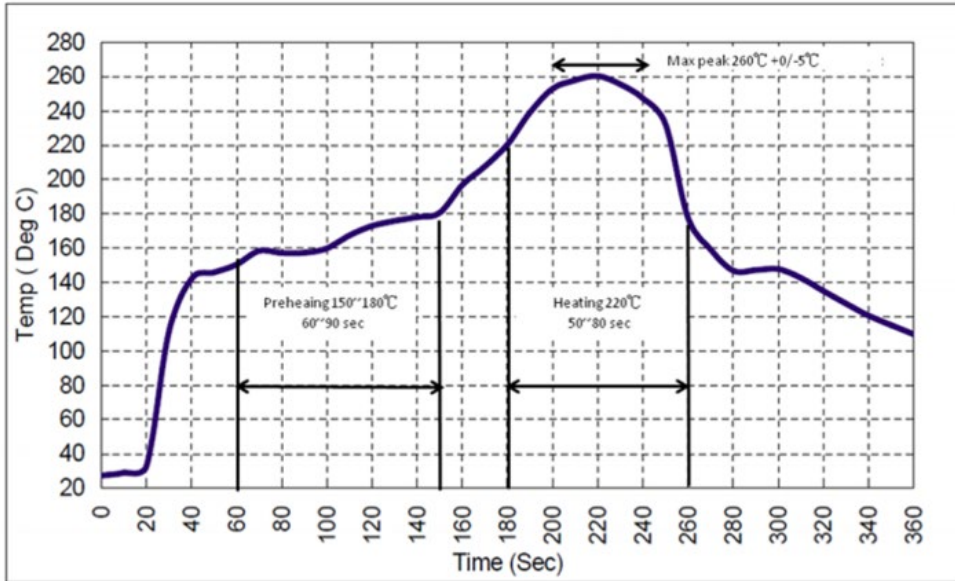

Recommended Reflow Profile

1. Preheating shall be fixed at 150~180°C for 60~90 seconds.
2. Ascending time to preheating temperature 150°C shall be 30 seconds min.
3. Heating shall be fixed at 220°C for 50~80 seconds and at 260°C +0/-5°C peak (10 seconds).
4. Time: 5 times maximum.



Looking for pricing, stock, or lifecycle information?

Click below to explore more details on WIN SOURCE:

-  [View SF2170D on WIN SOURCE](#)
-  [RF Monolithics, Inc Information](#)

Optimize Your Supply Chain with WIN SOURCE Solutions

-  Global Sourcing Solution
-  Obsolete Management
-  Cost Control Management
-  Shortage Management
-  Alternative Solution
-  Excess Inventory Management