



THE DATASHEET OF SF2304B



- **High Performance 175 MHz SAW Filter**
- **Hermetic 5 x 7 mm Surface-mount Case**
- **Single-ended or Differential Input Operation**
- **Complies with Directive 2002/95/EC (RoHS)**
- **Moisture Sensitivity Level: 1**
- **AEC-Q200 Qualified**

SF2304B

**175 MHz
SAW Filter**

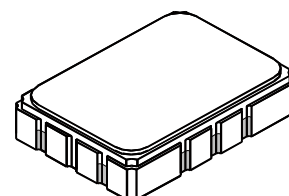

SMP-03

Absolute Maximum Ratings

Rating	Value	Units
Maximum Incident Power in Passband	+10	dBm
DC Voltage on any Non-ground Terminal	10	VDC
Operating Temperature Range	-40 to +85	°C
Storage Temperature Range in Tape and Reel	-40 to +85	°C
Suitable for Lead-free Soldering - Maximum Soldering Profile	260 °C for 30 s	

Characteristic	Sym	Notes	Min	Typ	Max	Units
Center Frequency	f_C			175		MHz
Minimum insertion Loss	IL_{MIN}			7.5	10	dB
Amplitude Ripple, $f_C \pm 0.45$ MHz				0.7	1.0	dB _{P-P}
Group Delay Ripple, $f_C \pm 0.45$ MHz				200	300	ns _{P-P}
Absolute Delay				0.68	1.50	µs
1 dB Bandwidth	BW_1		0.90	1.04		MHz
2.5 dB Bandwidth	$BW_{2.5}$		1.20	1.38		
3 dB Bandwidth	BW_3		1.30	1.46		
5 dB Bandwidth	BW_5		1.55	1.66	1.85	
30 dB Bandwidth	BW_{30}			3.21	3.65	
40 dB Bandwidth	BW_{40}			3.47	3.95	
Ultimate Rejection, 186 to 900 MHz			47	50		dB
Input/Output Return Loss, $f_C \pm 0.45$ MHz			10	12		dB

Single-ended Terminating Source Impedance		$Z_S = 50$ ohms
Differential Terminating Source Impedance		$Z_S = 100$ ohms
Terminating Load Impedance		$Z_L = 50$ ohms
Case Style		SMP-03 7 x 5 mm Nominal Footprint
Lid Symbolization, YY = year, WW = week, S = shift, ## = Sequence Code)		RFM, SF2304B, <u>YYWWS##</u>

Electrical Connection

Connection	Terminals
Single-ended Input Port	10
Balanced Input Port	10, 1
Single-ended Output Port	5
Ground	All others

 **CAUTION: Electrostatic Sensitive Device. Observe precautions for handling.**

NOTES:

1. The design, manufacturing process, and specifications of this device are subject to change.
2. US or International patents may apply.
3. RoHS compliant from the first date of manufacture.

Filter Response Plots

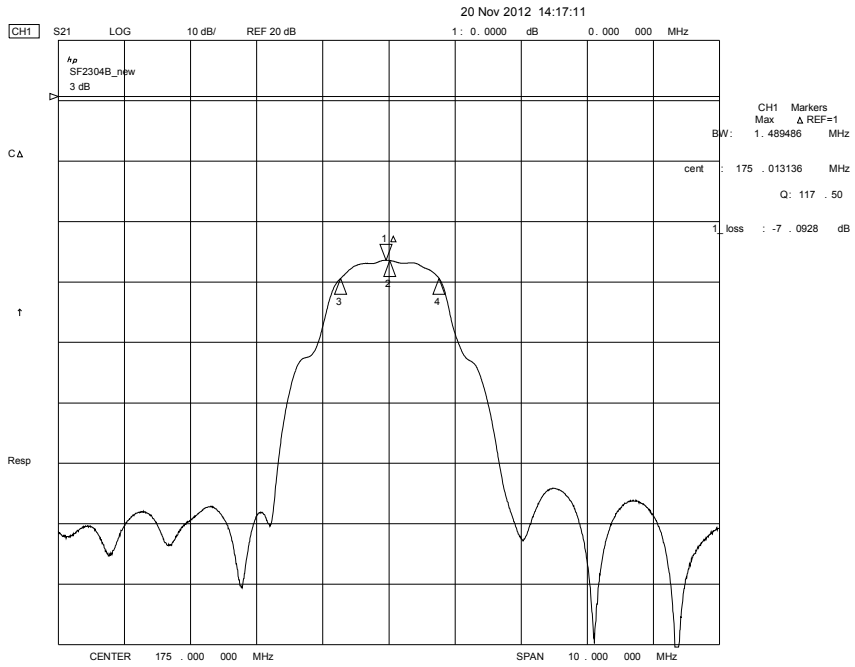
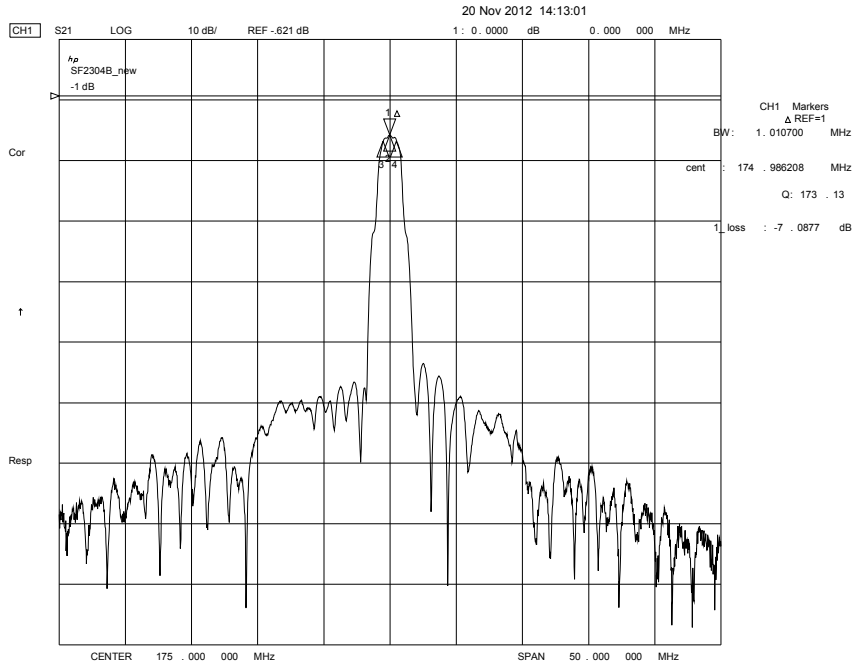

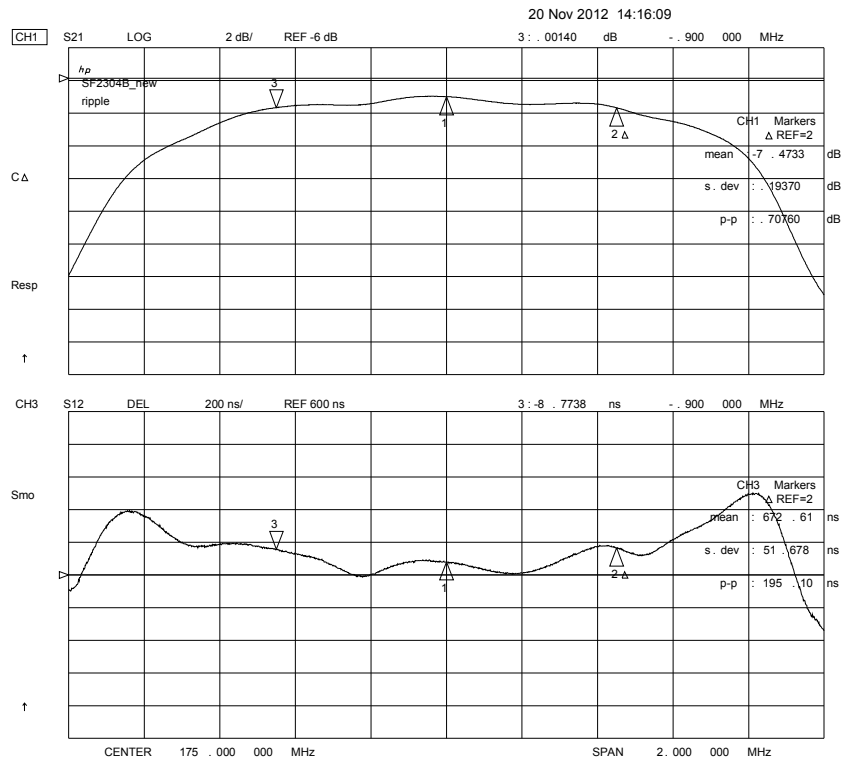

Typical Matching Network

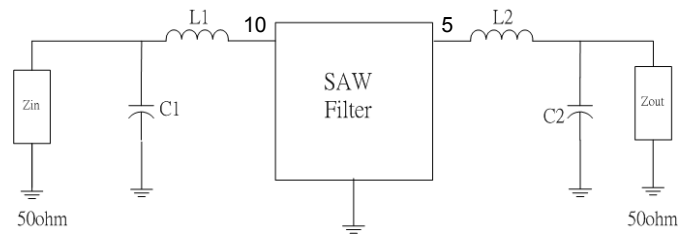

$$C1 = 33 \text{ pF}, L1 = (150 + 22) \text{ nH}, L2 = (24 + 150) \text{ nH}, C2 = 36 \text{ pF}$$

SMP-03 10-Terminal Ceramic Surface-mount Case

5 x 7 mm Nominal Footprint

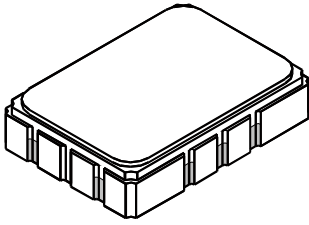

Recommended PCB Footprint

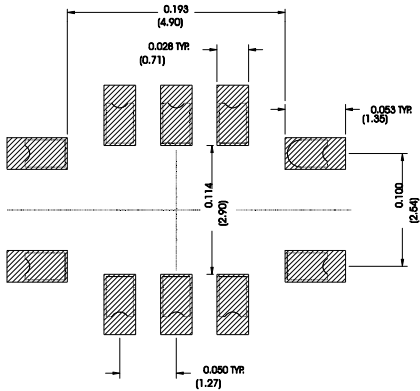

Case Dimensions						
Dimension	mm			Inches		
	Min	Nom	Max	Min	Nom	Max
A	6.80	7.00	7.20	0.268	0.276	0.283
B	4.80	5.00	5.20	0.189	0.197	0.205
C	-	1.65	2.00	-	0.065	0.079
D	0.47	0.60	0.73	0.019	0.024	0.029
E	2.41	2.54	2.67	0.095	0.100	0.105
H	0.87	1.0	1.13	0.034	0.039	0.044
J	4.87	5.00	5.13	0.192	0.197	0.202
K	2.87	3.00	3.13	0.113	0.118	0.123
P	1.14	1.27	1.40	0.045	0.050	0.055

Electrical Connections		
Connection	Terminals	
Port 1	Single-ended Input	10
Port 1	Differential Input	10, 1
Port 2	Single-ended Output	5
	Ground	All others

Case Materials	
Solder Pad Plating	0.3 to 1.0 μm Gold over 1.27 to 8.89 μm Nickel
Lid Plating	2.0 to 3.0 μm Nickel
Body	Al_2O_3 Ceramic

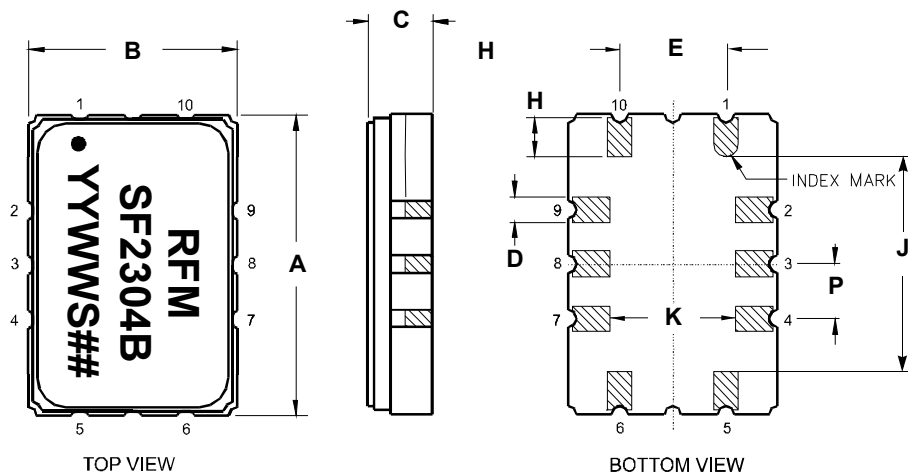

Tape and Reel Specifications

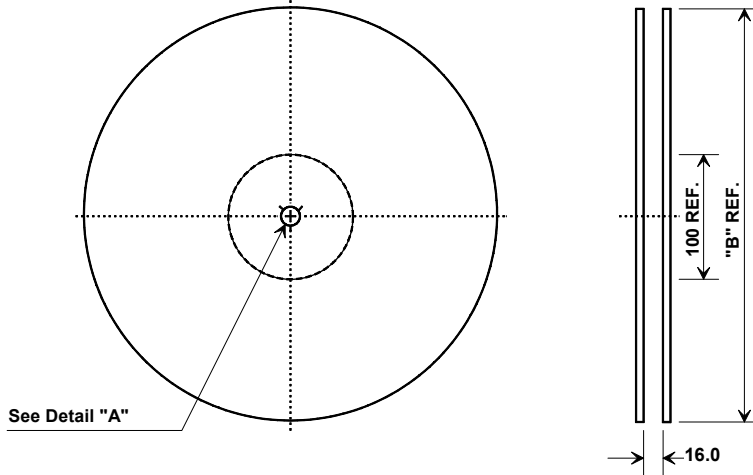

Tape and Reel Standard per ANSI/EIA-481

"B"		Quantity Per Reel
Nominal Size		
Inches	millimeters	
7	178	500
13	330	2000

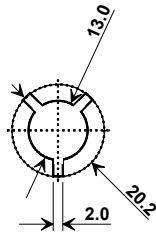

COMPONENT ORIENTATION and DIMENSIONS

Carrier Tape Dimensions	
Ao	5.6 mm
Bo	7.6 mm
Ko	2.0 mm
Pitch	8.0 mm
W	16.0 mm

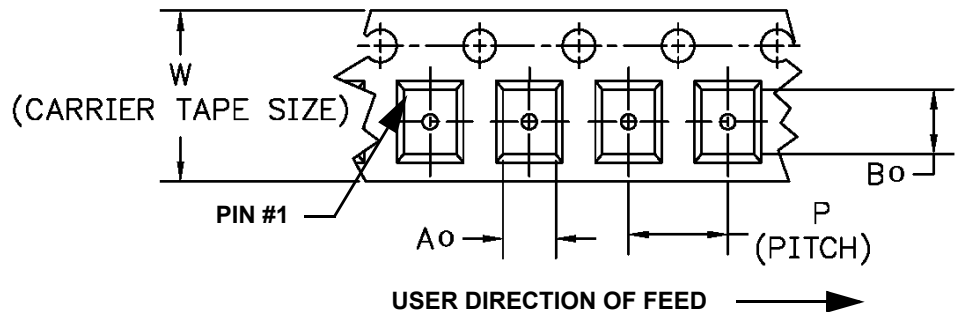
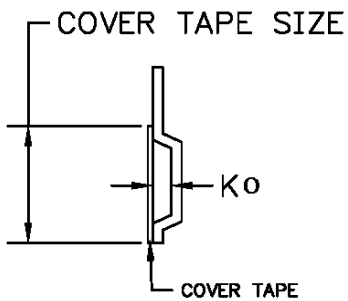

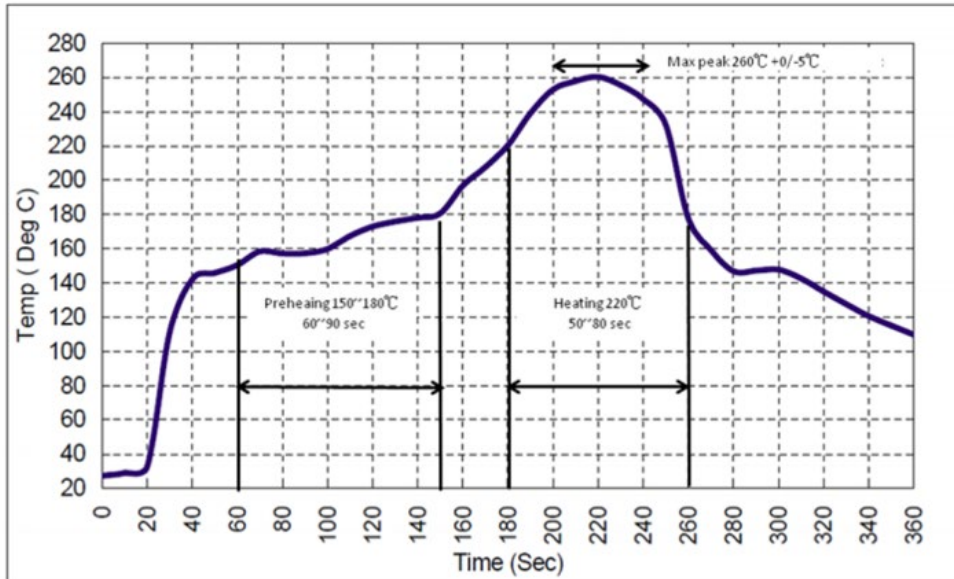

Recommended Reflow Profile

1. Preheating shall be fixed at 150~180°C for 60~90 seconds.
2. Ascending time to preheating temperature 150°C shall be 30 seconds min.
3. Heating shall be fixed at 220°C for 50~80 seconds and at 260°C +0/-5°C peak (10 seconds).
4. Time: 5 times maximum.



Looking for pricing, stock, or lifecycle information?

Click below to explore more details on WIN SOURCE:

-  [View SF2304B on WIN SOURCE](#)
-  [RF Monolithics, Inc Information](#)

Optimize Your Supply Chain with WIN SOURCE Solutions

-  Global Sourcing Solution
-  Obsolete Management
-  Cost Control Management
-  Shortage Management
-  Alternative Solution
-  Excess Inventory Management