



**THE DATASHEET OF  
SF2237C**



- High Performance SAW Filter
- 5 x 5 mm Surface-mount Package
- Complies with Directive 2011/65/EU (RoHS)
- Moisture Sensitivity Level: 1
- AEC-Q200 Qualified

#### Absolute Maximum Ratings

Rating	Value	Units
Maximum Incident Power in Passband	+10	dBm
Maximum DC Voltage Between any Two Active Terminals	3	VDC
Operable Temperature Range	-45 to +125	°C
Specification Temperature Range	-40 to +85	°C
Storage Temperature Range in Tape and Reel	-40 to +85	°C
Suitable for Lead-free Soldering - Maximum Soldering Profile	260 °C for 30 s	

**SF2237C**

**515.0 MHz  
SAW Filter**

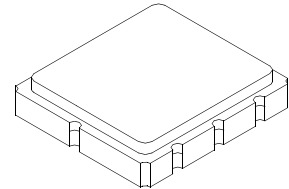

**SM5050-8**

#### Electrical Characteristics

Characteristic	Sym	Notes	Min	Typ	Max	Units
Nominal Center Frequency	$f_c$			515.0		MHz
Insertion Loss @ 510 - 520 MHz				2.7	3.0	dB
1 dB Bandwidth	$BW_1$		18	34		MHz
Amplitude Ripple, $f_c \pm 11.5$ MHz				0.6	1.5	dB <sub>P-P</sub>
Rejection referenced to IL at Peak:						
400 to 430 MHz			35	50		dB
430 to 470 MHz			32	40		
550 to 600 MHz			20	30		
600 to 740 MHz			35	40		
Frequency Temperature Drift				-93		ppm/°C

Case Style	5 x 5 mm Nominal Footprint	
Lid Symbolization, Y=year, WW=week, S=shift, Dot=pin 1 indicator	971, <u>YWWS</u>	
Standard Reel Quantity	Reel Size 7 Inch	500 Pieces/Reel
	Reel Size 13 Inch	3000 Pieces/Reel

#### Electrical Connections

Connection	Terminals
Input	1
Output	5
Case Ground	All others

 **CAUTION: Electrostatic Sensitive Device. Observe precautions for handling.**

#### NOTES:

1. The design, manufacturing process, and specifications of this device are subject to change.
2. US or International patents may apply.
3. RoHS compliant from the first date of manufacture.

## Filter Amplitude and Group Delay Response Plots

S21 Response: (span 350 MHz)

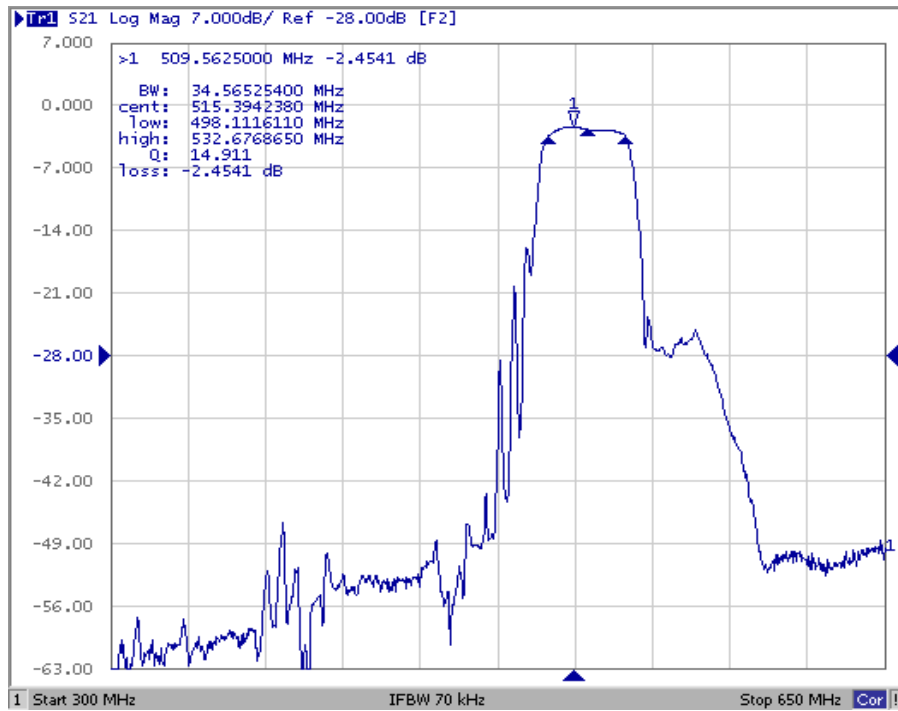

Group Delay Response: (span 50 MHz)

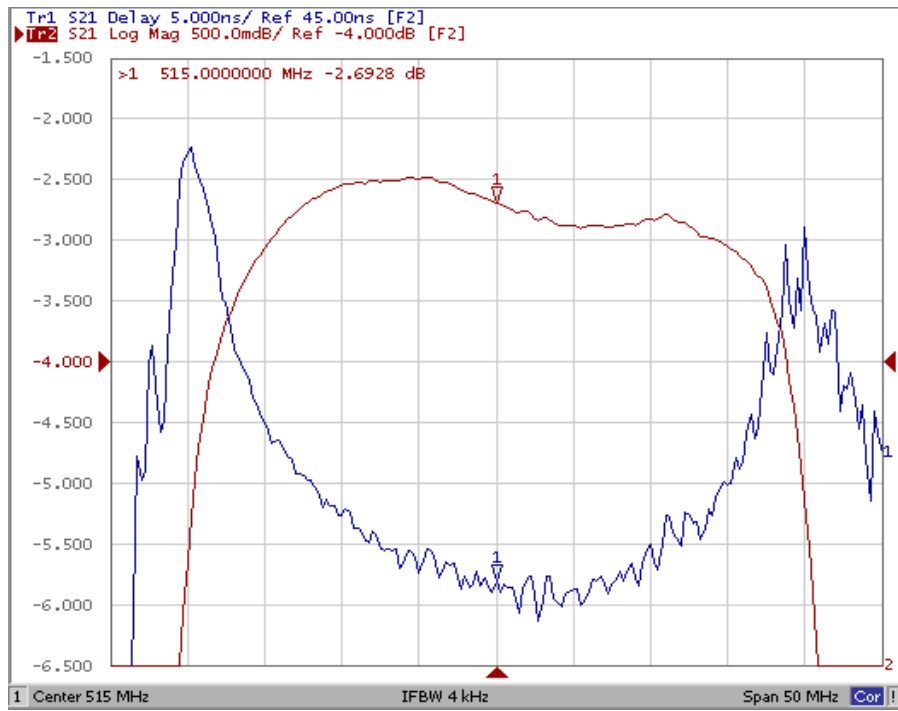

S11 Smith Chart: (span 350 MHz)

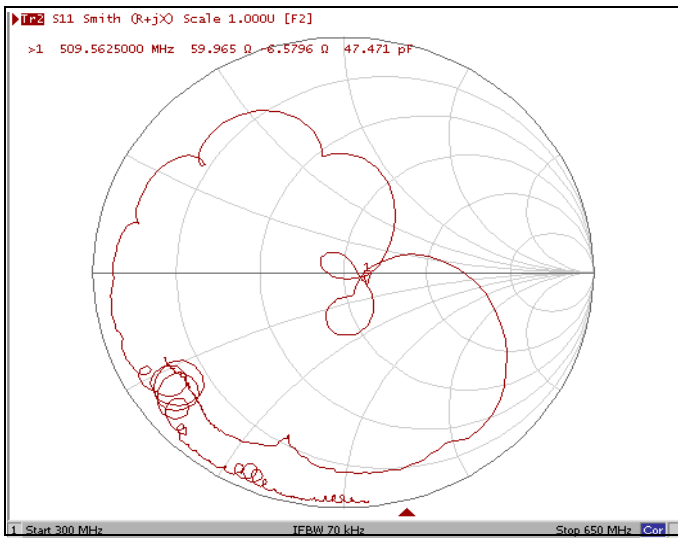

S22 Smith Chart: (span 350 MHz)

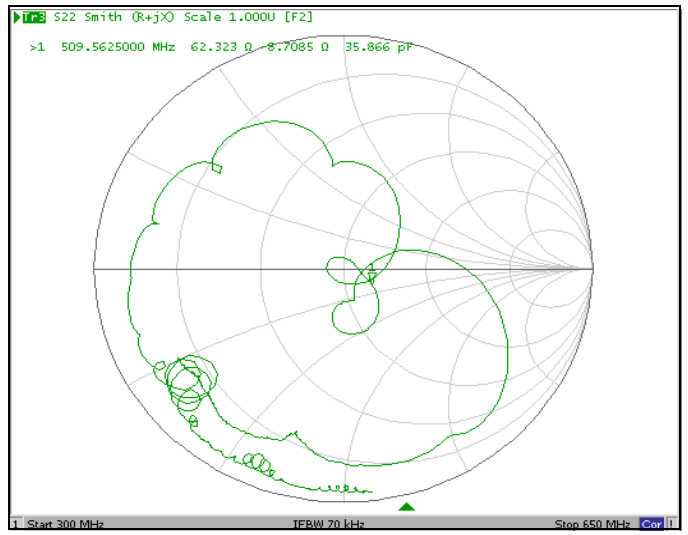

### Test Circuit

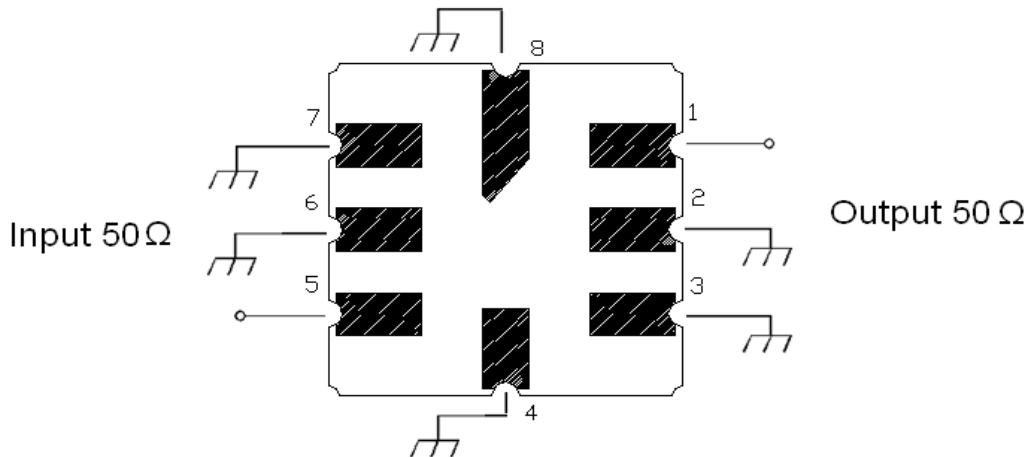

# SM5050-8 Case

## 8-Terminal Ceramic Surface-Mount Case 5.0 X 5.0 mm Nominal Footprint

### Case Dimensions

Dimension	mm			Inches		
	Min	Nom	Max	Min	Nom	Max
A	4.80	5.00	5.20	0.189	0.197	0.205
B	4.80	5.00	5.20	0.189	0.197	0.205
C	1.30	1.50	1.70	0.050	0.060	0.067
D	1.98	2.08	2.18	0.078	0.082	0.086
E	1.07	1.17	1.27	0.042	0.046	0.050
F	0.50	0.64	0.70	0.020	0.025	0.028
G	2.39	2.54	2.69	0.094	0.100	0.106
H		1.35			0.053	

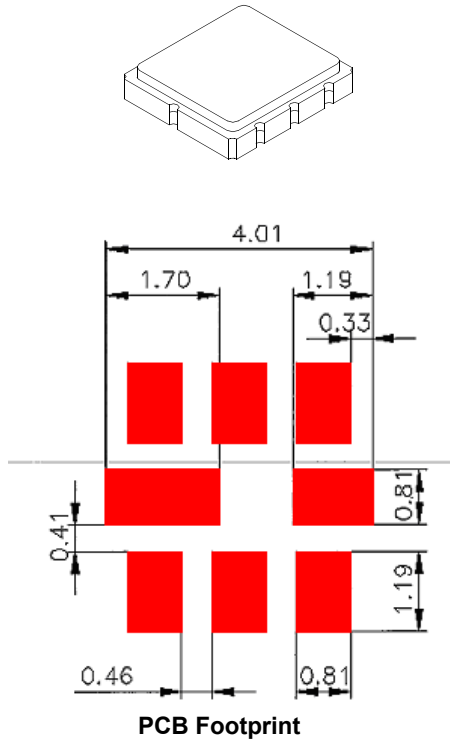

### Case Materials

Materials	
Solder Pad Plating	0.3 to 1.0 $\mu\text{m}$ Gold over 1.27 to 8.89 $\mu\text{m}$ Nickel
Lid Plating	2.0 to 3.0 $\mu\text{m}$ Nickel
Body	$\text{Al}_2\text{O}_3$ Ceramic

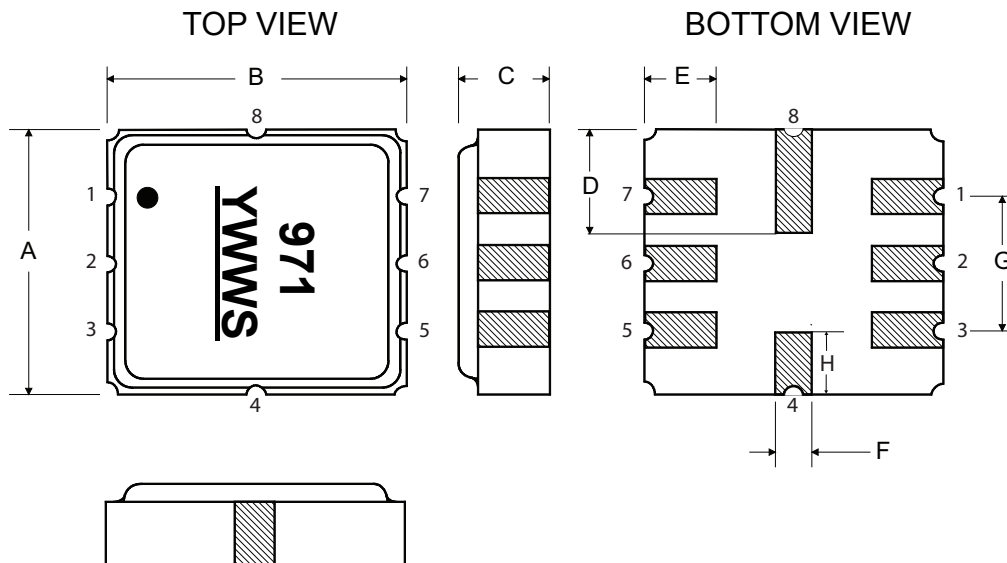

## Tape and Reel Specifications

Tape and Reel Standard per ANSI/EIA-481

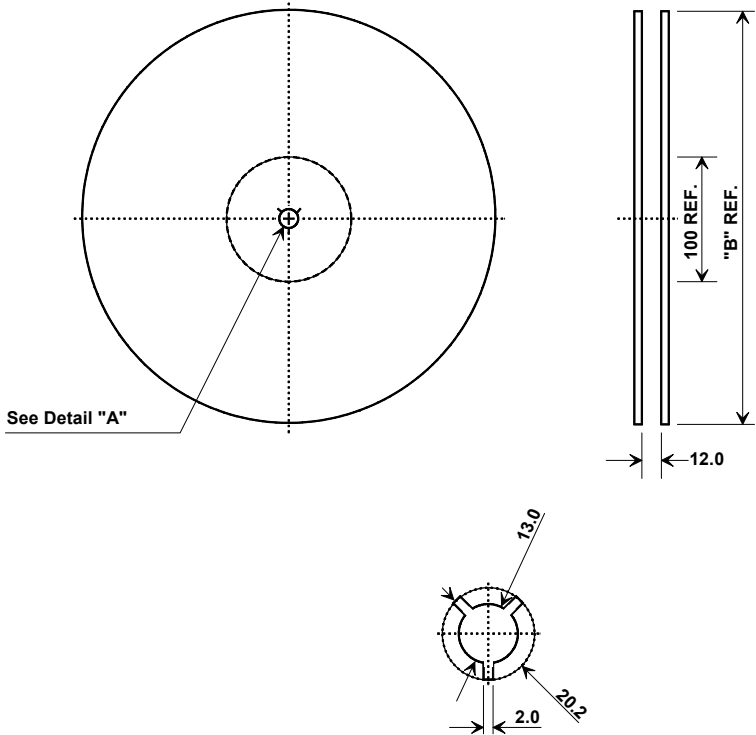

"B" Nominal Size		Quantity Per Reel
Inches	millimeters	
7	178	500
13	330	3000

### COMPONENT ORIENTATION and DIMENSIONS

Carrier Tape Dimensions	
Ao	5.3 mm
Bo	5.3 mm
Ko	2.0 mm
Pitch	8.0 mm
W	12.0 mm

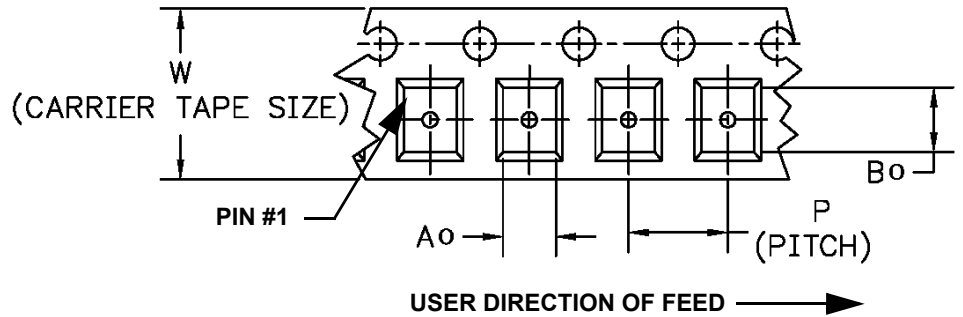
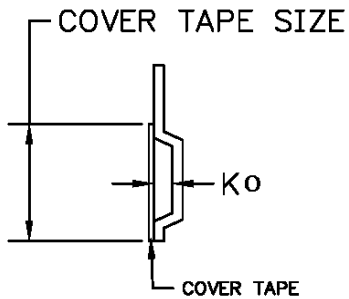

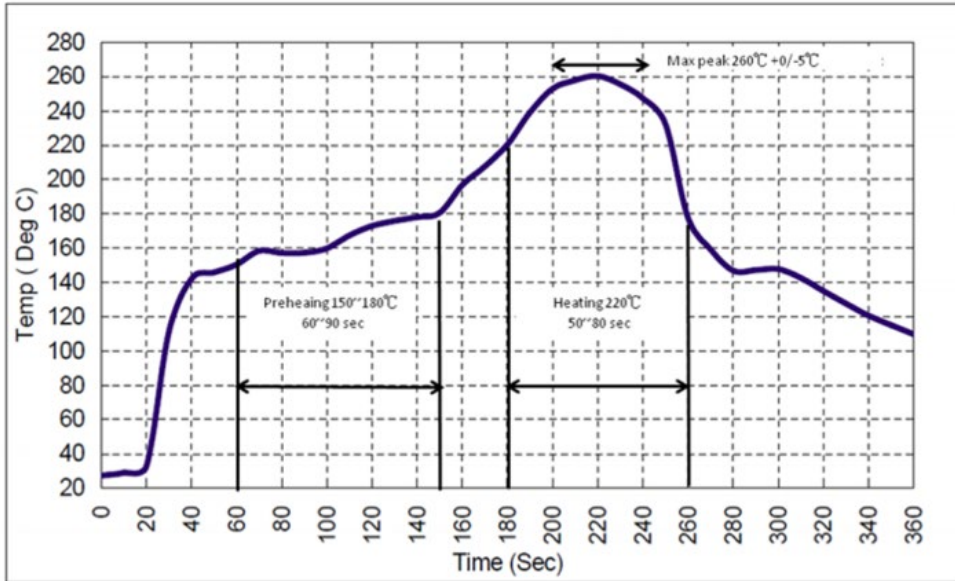

## Recommended Reflow Profile

1. Preheating shall be fixed at 150~180°C for 60~90 seconds.
2. Ascending time to preheating temperature 150°C shall be 30 seconds min.
3. Heating shall be fixed at 220°C for 50~80 seconds and at 260°C +0/-5°C peak (10 seconds).
4. Time: 5 times maximum.



## Looking for pricing, stock, or lifecycle information?

Click below to explore more details on WIN SOURCE:

-  [View SF2237C on WIN SOURCE](#)
-  [RF Monolithics, Inc Information](#)

## Optimize Your Supply Chain with WIN SOURCE Solutions

-  Global Sourcing Solution
-  Obsolete Management
-  Cost Control Management
-  Shortage Management
-  Alternative Solution
-  Excess Inventory Management