



# THE DATASHEET OF SF2425E



- 868.6 MHz Low-loss SAW Filter
- Surface Mount 3.0 x 3.0 mm Package
- Complies with Directive 2002/95/EC (RoHS)
- Moisture Sensitivity Level: 1

#### Absolute Maximum Ratings

Rating	Value	Units
Input Power Level	15	dBm
DC Voltage on any Non-ground Terminal	5	V
Operable Temperature Range	-45 to +125	°C
Specification Temperature Range	-40 to +85	°C
Storage Temperature Range in Tape and Reel	-40 to +85	°C
Solder Reflow Temperature, 10 seconds, 5 cycles maximum	260	°C

**SF2425E**

**868.6 MHz  
SAW Filter**

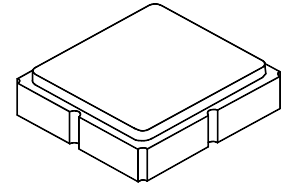

**SM3030-8**

#### Electrical Characteristics

Characteristic	Sym	Notes	Min	Typ	Max	Units
Center Frequency	$f_C$			868.6		MHz
Minimum Insertion Loss, incl. loss of matching elements	$IL_{MIN}$			2.65	3.50	dB
3dB BW			1.3	1.5		MHz
Attenuation (Relative to $IL_{min}$ )						dB
10.00 to 820.00 MHz			40	45		
820.00 to 859.00 MHz			28	33		
859.00 to 866.60 MHz			18	23		
866.60 to 867.20 MHz			10	14		
870.40 to 871.40 MHz			10	20		
871.40 to 875.00 MHz			15	19		
875.00 to 890.00 MHz			14	17		
890.00 to 950.00 MHz			32	36		
950.00 to 1500.00 MHz			50	55		
1500.00 to 2420.00 MHz			48	65		
2420.00 to 2500.00 MHz			-35	-40		
Case Style	SM3030-8 3.0 x 3.0 mm Nominal Footprint					
Lid Symbolization, Y=year, WW=week, S=shift, dot=pin 1 indicator	8J, YWWS					
INPUT $Z_{in} = R_{in}    C_{in}$				386  1.6		$\Omega    pF$
OUTPUT $Z_{out} = R_{out}    C_{out}$				371  1.8		



**CAUTION: Electrostatic Sensitive Device. Observe precautions for handling.**

#### NOTES:

1. The design, manufacturing process, and specifications of this device are subject to change.
2. US or International patents may apply.
3. RoHS compliant from the first date of manufacture.

# Frequency Characteristics

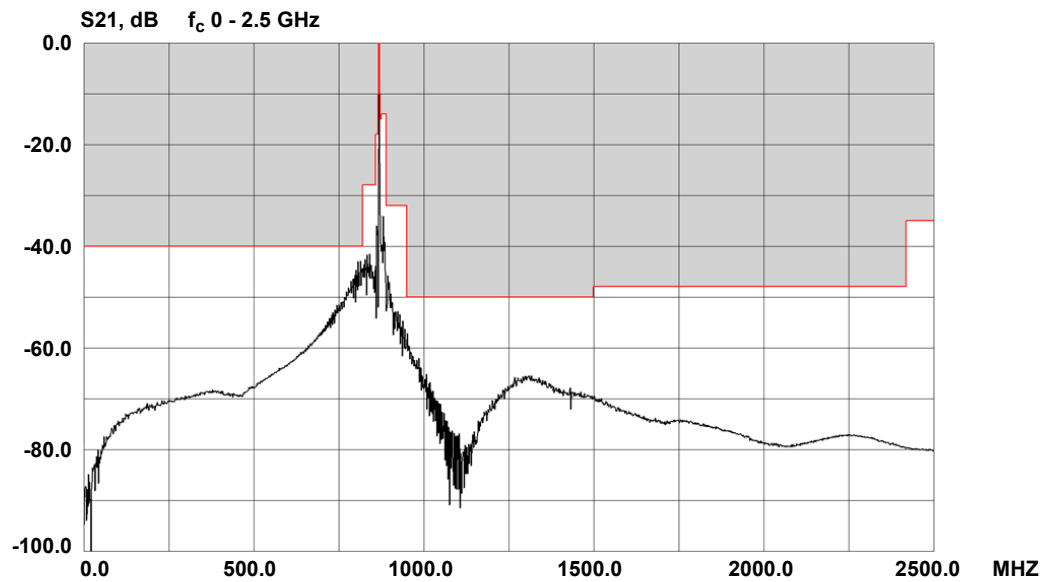
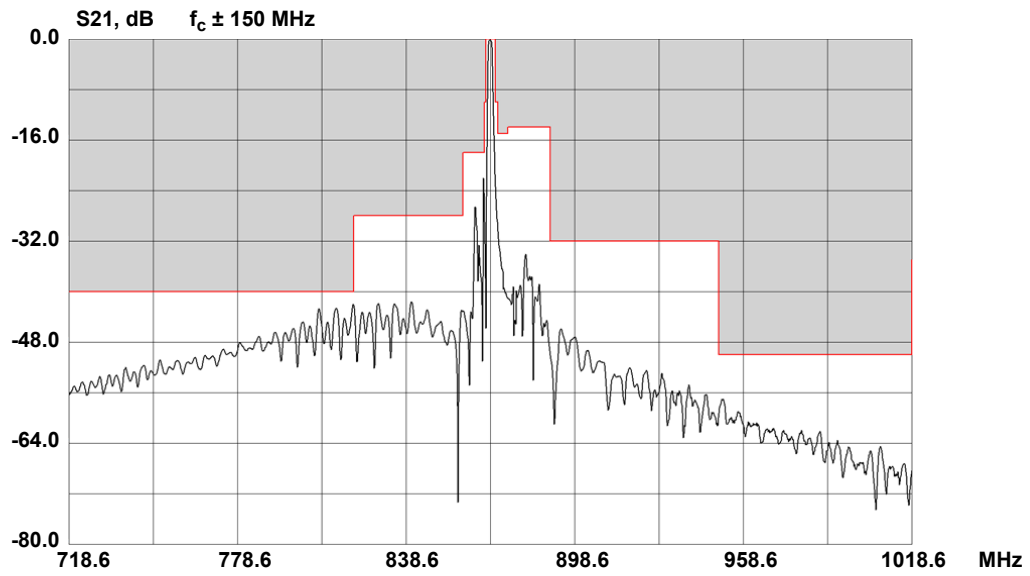
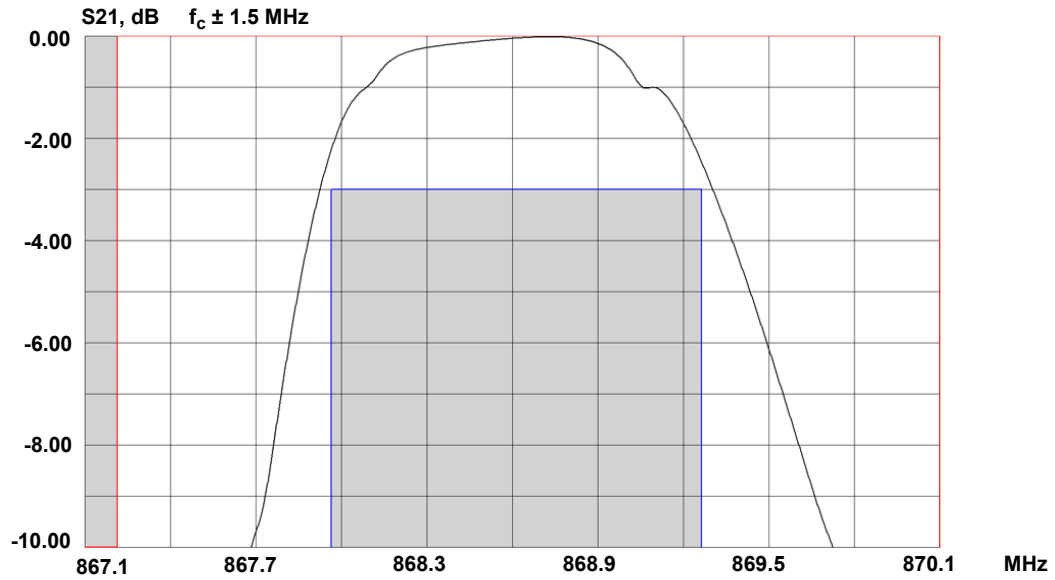

# SM3030-8 Case

## 8-Terminal Ceramic Surface-Mount Case 3.0 X 3.0 mm Nominal Footprint

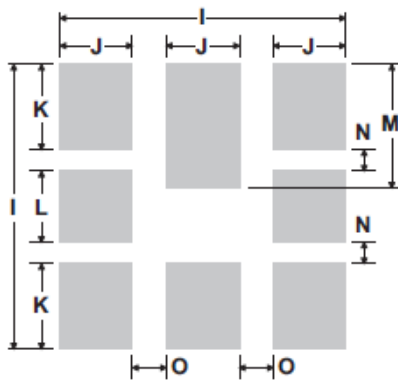
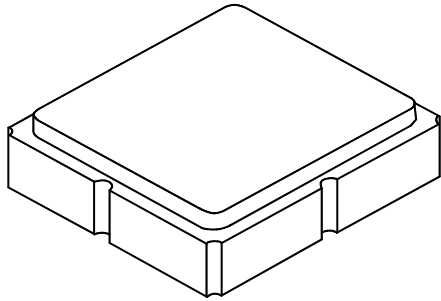

PCB Land Pattern  
Top View

### Electrical Connections

Connection	Terminals
Input Ground or Input	1
Input or Input Ground	2
Output Ground or Output	5
Output or Output Ground	6
Ground	3, 4, 7, 8

TOP VIEW

### Case and PCB Footprint Dimensions

Dimension	mm			Inches		
	Min	Nom	Max	Min	Nom	Max
A	2.87	3.00	3.13	0.113	0.118	0.123
B	2.87	3.00	3.13	0.113	0.118	0.123
C	-	-	1.10	-	-	0.043
D	0.79	0.92	1.05	0.031	0.036	0.041
E	0.62	0.75	0.88	0.024	0.029	0.034
F	0.47	0.60	0.73	0.018	0.024	0.029
G	0.47	0.60	0.73	0.018	0.024	0.029
H	1.07	1.20	1.33	0.042	0.047	0.052
I		3.19			0.126	
J		0.81			0.032	
K		0.96			0.038	
L		0.81			0.032	
M		1.39			0.055	
N		0.23			0.009	
O		0.38			0.015	

### Case Materials

Materials	
Solder Pad Plating	0.3 to 1.0 $\mu\text{m}$ Gold over 1.27 to 8.89 $\mu\text{m}$ Nickel
Lid Plating	2.0 to 3.0 $\mu\text{m}$ Nickel
Body	$\text{Al}_2\text{O}_3$ Ceramic

### Test Circuit

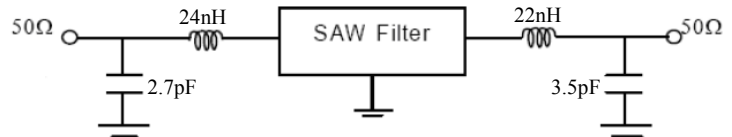

BOTTOM VIEW

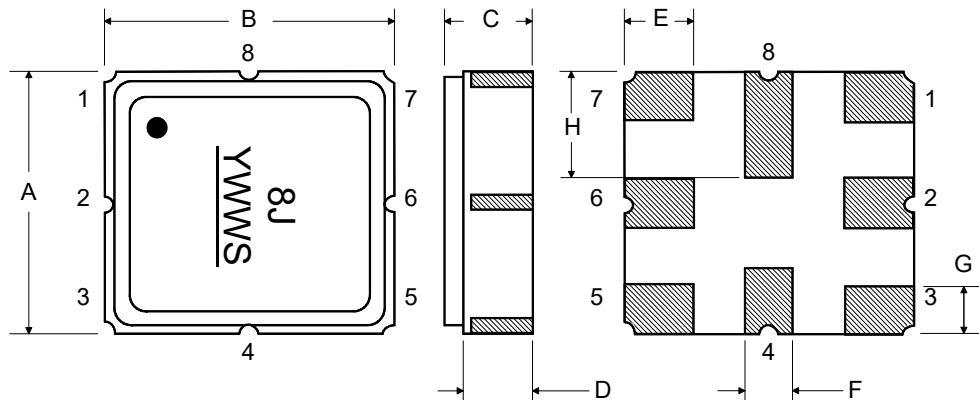

## Tape and Reel Specifications

Tape and Reel Standard per ANSI/EIA-481

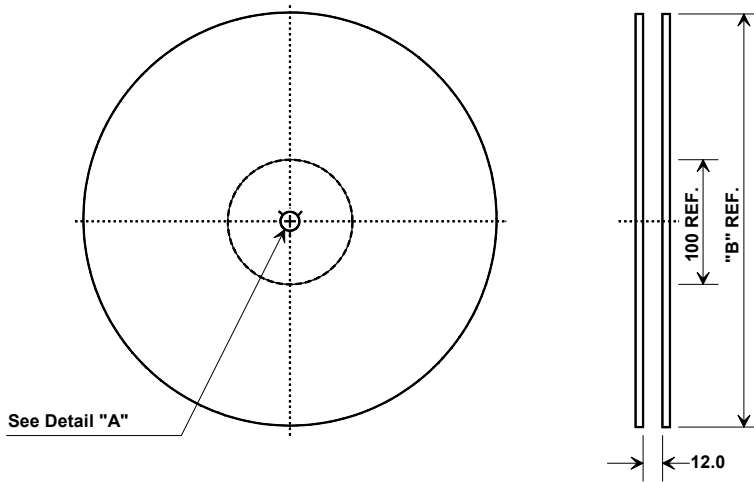

"B"		Quantity Per Reel
Inches	millimeters	
7	178	500
13	330	3000

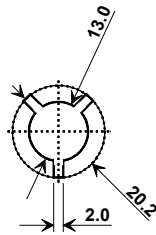

### COMPONENT ORIENTATION and DIMENSIONS

Carrier Tape Dimensions	
Ao	3.3 ± 1 mm
Bo	3.3 ± 1 mm
Ko	1.4 ± 1 mm
Pitch	4.0 mm
W	12.0 ± 3 mm

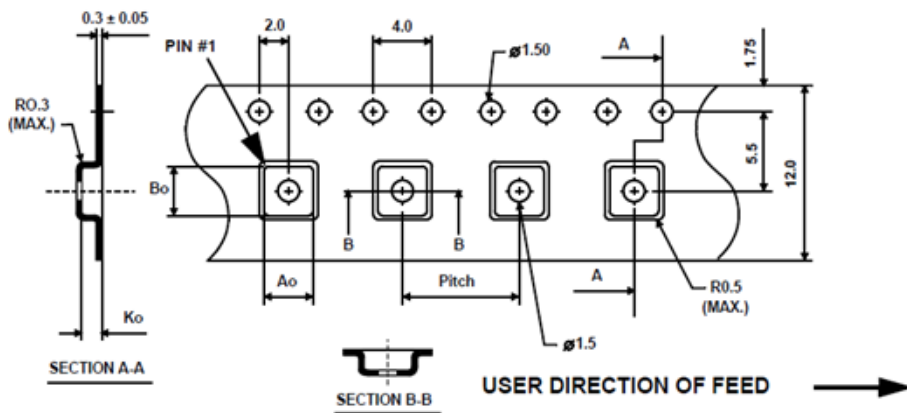

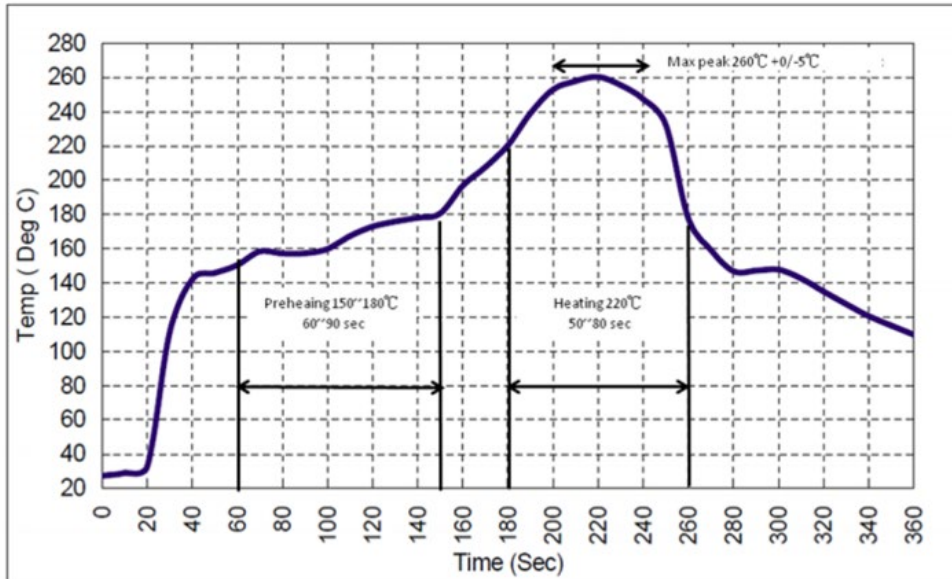

## Recommended Reflow Profile

1. Preheating shall be fixed at 150~180°C for 60~90 seconds.
2. Ascending time to preheating temperature 150°C shall be 30 seconds min.
3. Heating shall be fixed at 220°C for 50~80 seconds and at 260°C +0/-5°C peak (10 seconds).
4. Time: 5 times maximum.



## Looking for pricing, stock, or lifecycle information?

Click below to explore more details on WIN SOURCE:

-  [View SF2425E on WIN SOURCE](#)
-  [RF Monolithics, Inc Information](#)

## Optimize Your Supply Chain with WIN SOURCE Solutions

-  Global Sourcing Solution
-  Obsolete Management
-  Cost Control Management
-  Shortage Management
-  Alternative Solution
-  Excess Inventory Management