



THE DATASHEET OF DAC5686IPZP



16-BIT, 500-MSPS, 2x–16x INTERPOLATING DUAL-CHANNEL DIGITAL-TO-ANALOG CONVERTER

FEATURES

- 500-MSPS Maximum-Update-Rate DAC
- WCDMA ACPR
 - 1 Carrier: 76 dB Centered at 30.72-MHz IF, 245.76 MSPS
 - 1 Carrier: 73 dB Centered at 61.44-MHz IF, 245.76 MSPS
 - 2 Carrier: 72 dB Centered at 30.72-MHz IF, 245.76 MSPS
 - 4 Carrier: 64 dB Centered at 92.16-MHz IF, 491.52 MSPS
- Selectable 2x, 4x, 8x, and 16x Interpolation
 - Linear Phase
 - 0.05-dB Pass-Band Ripple
 - 80-dB Stop-Band Attenuation
 - Stop-Band Transition 0.4–0.6 f_{DATA}
- 32-Bit Programmable NCO
- On-Chip 2x–16x PLL Clock Multiplier With Bypass Mode
- Differential Scalable Current Outputs: 2 mA to 20 mA
- On-Chip 1.2-V Reference

- 1.8-V Digital and 3.3-V Analog Supplies
- 1.8-V/3.3-V CMOS-Compatible Interface
- Power Dissipation: 950 mW at Full Maximum Operating Conditions
- Package: 100-Pin HTQFP

APPLICATIONS

- Cellular Base Transceiver Station Transmit Channel
 - CDMA: W-CDMA, CDMA2000, IS-95
 - TDMA: GSM, IS-136, EDGE/UWC-136
- Baseband I and Q Transmit
- Input Interface: Quadrature Modulation for Interfacing With Baseband Complex Mixing ASICs
- Single-Sideband Up-Conversion
- Diversity Transmit
- Cable Modem Termination System

DESCRIPTION

The DAC5686 is a dual-channel 16-bit high-speed digital-to-analog converter (DAC) with integrated 2x, 4x, 8x, and 16x interpolation filters, a numerically controlled oscillator (NCO), onboard clock multiplier, and on-chip voltage reference. The DAC5686 has been specifically designed to allow for low input data rates between the DAC and ASIC, or FPGA, and high output transmit intermediate frequencies (IF). Target applications include high-speed digital data transmission in wired and wireless communication systems and high-frequency direct-digital synthesis DDS.

The DAC5686 provides three modes of operation: dual-channel, single-sideband, and quadrature modulation. In dual-channel mode, interpolation filtering increases the DAC update rate, which reduces sinc/x rolloff and enables the use of relaxed analog post-filtering.

Single-sideband mode provides an alternative interface to the analog quadrature modulators. Channel carrier selection is performed at baseband by mixing in the ASIC/FPGA. Baseband I and Q from the ASIC/FPGA are input to the DAC5686, which in turn performs a complex mix resulting in Hilbert transform pairs at the outputs of the DAC5686's two DACs. An external RF quadrature modulator then performs the final single-sideband up-conversion. The DAC5686's complex mixing frequencies are flexibly chosen with the 32-bit programmable NCO.



Please be aware that an important notice concerning availability, standard warranty, and use in critical applications of Texas Instruments semiconductor products and disclaimers thereto appears at the end of this data sheet.

PowerPAD is a trademark of Texas Instruments.

Excel is a trademark of Microsoft Corporation.

All other trademarks are the property of their respective owners.

Unmatched gains and offsets at the RF quadrature modulator result in unwanted sideband and local oscillator feedthrough. Each DAC in the DAC5686 has an 11-bit offset adjustment and 12-bit gain adjustment, which compensate for quadrature modulator input imbalances, thus reducing RF filtering requirements.

In quadrature modulation mode, on-chip mixing provides baseband-to-IF up-conversion. Mixing frequencies are flexibly chosen with a 32-bit programmable NCO. Channel carrier selection is performed at baseband by complex mixing in the ASIC/FPGA. Baseband I and Q from the ASIC/FPGA are input to the DAC5686, which interpolates the low data-rate signal to higher data rates. The single DAC output from the DAC5686 is the final IF single-sideband spectrum presented to RF.

The 2x, 4x, 8x, and 16x interpolation filters are implemented as a cascade of half-band 2x interpolation filters. Unused filters for interpolation rates of less than 16x are shut off to reduce power consumption. The DAC5686 provides a full bypass mode, which enables the user to bypass all the interpolation and mixing.

The DAC5686 PLL clock multiplier controls all internal clocks for the digital filters and the DAC cores. The differential clock input and internal clock circuitry provides for optimum jitter performance. Sine wave clock input signal is supported. The PLL can be bypassed by an external clock running at the DAC core update rate. The clock divider of the PLL ensures that the digital filters operate at the correct clock frequencies.

The DAC5686 operates with an analog supply voltage of 3.3 V and a digital supply voltage of 1.8 V. Digital I/Os are 1.8-V and 3.3-V CMOS compatible. Power dissipation is 950 mW at maximum operating conditions. The DAC5686 provides a nominal full-scale differential current output of 20 mA, supporting both single-ended and differential applications. The output current can be directly fed to the load with no additional external output buffer required. The device has been specifically designed for a differential transformer-coupled output with a 50-Ω doubly terminated load. For a 20-mA full-scale output current, both a 4:1 impedance ratio (resulting in an output power of 4 dBm) and 1:1 impedance ratio transformer (–2-dBm output power) are supported.

The DAC5686 operational modes are configured by programming registers through a serial interface. The serial interface can be configured to either a 3- or 4-pin interface allowing it to communicate with many industry-standard microprocessors and microcontrollers. Data (I and Q) can be input to the DAC5686 as separate parallel streams on two data buses, or as a single interleaved data stream on one data bus.

An accurate on-chip 1.2-V temperature-compensated band-gap reference and control amplifier allows the user to adjust the full-scale output current from 20 mA down to 2 mA. This provides 20-dB gain range control capabilities. Alternatively, an external reference voltage can be applied for maximum flexibility. The device features a SLEEP mode, which reduces the standby power to approximately 10 mW, thereby minimizing the system power consumption.

The DAC5686 is available in a 100-pin HTQFP package. The device is characterized for operation over the industrial temperature range of –40C to 85C.

ORDERING INFORMATION

T_A	PACKAGE DEVICES
–40C to 85C	100 HTQFP ⁽¹⁾ (PZP) PowerPAD™ plastic quad flatpack
	DAC5686IPZP

(1) Thermal pad size: 6 mm × 6 mm

FUNCTIONAL BLOCK DIAGRAM

Block Diagram of the DAC5686

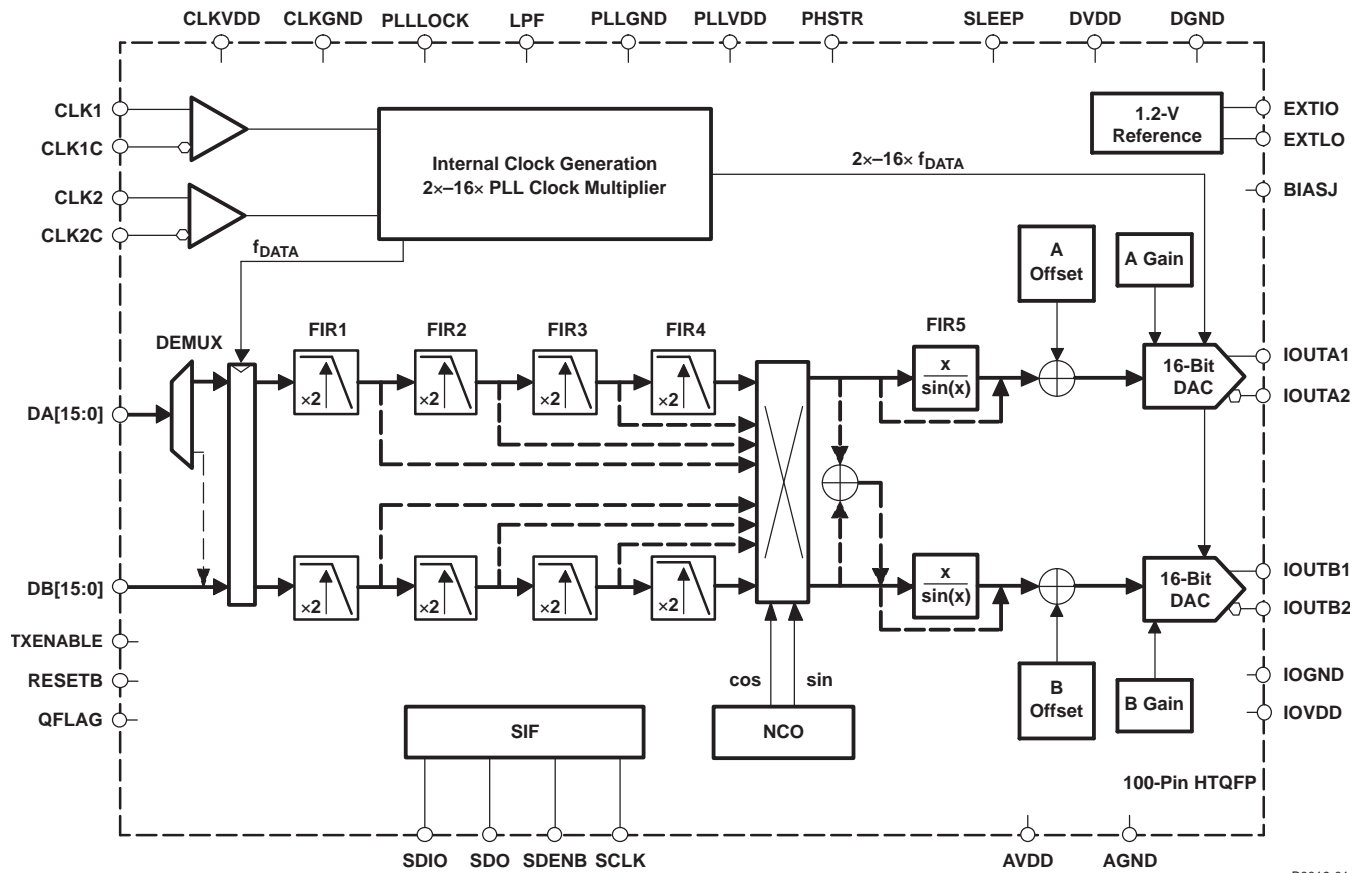

B0019-01

DEVICE INFORMATION

Terminal Functions

TERMINAL NAME	NO.	I/O	DESCRIPTION
AGND	1, 4, 7, 9, 12, 17, 19, 22, 25	I	Analog ground return
AVDD	2, 3, 8, 10, 14, 16, 18, 23, 24	I	Analog supply voltage
BIASJ	13	I/O	Full-scale output current bias
CLK1	59	I	External clock input; data clock input
CLK1C	60	I	Complementary external clock input; data clock input
CLK2	62	I	External clock input; sample clock for the DAC (optional if PLL disabled)
CLK2C	63	I	Complementary external clock input; sample clock for the DAC (optional if PLL disabled)
CLKGND	58, 64		Ground return for internal clock buffer
CLKVDD	61		Internal clock buffer supply voltage
DA[15:0]	34–36, 39–43, 48–55	I	A-channel data bits 0 through 15 DA15 is most significant data bit (MSB). DA0 is least significant data bit (LSB). Internal pulldown
DB[15:0]	92–90, 87–83, 78–71	I	B-channel data bits 0 through 15 DB15 is most significant data bit (MSB). DB0 is least significant data bit (LSB). Internal pulldown Note: The order of the B data bus can be reversed by register rev_bbus.
DGND	27, 38, 45, 57, 69, 81, 88, 93, 99		Digital ground return
DVDD	26, 32, 37, 44, 56, 68, 82, 89, 100		Digital supply voltage
EXTIO	11	I	Used as external reference input when internal reference is disabled (i.e., EXTLO connected to AVDD). Used as internal reference output when EXTLO = AGND, requires a 0.1- μ F decoupling capacitor to AGND when used as reference output
EXTLO	15	I	Internal reference ground. Connect to AVDD to disable the internal reference
IOUTA1	21	O	A-channel DAC current output. Full scale when all input bits are set to 1
IOUTA2	20	O	A-channel DAC complementary current output. Full scale when all input bits are set to 0
IOUTB1	5	O	B-channel DAC current output. Full scale when all input bits are set to 1
IOUTB2	6	O	B-channel DAC complementary current output. Full scale when all input bits are set to 0
IOGND	47, 79		Digital I/O ground return
IOVDD	46, 80		Digital I/O supply voltage
LPF	66	I/O	PLL loop filter connection. Can be left open or connected to GND if PLL is not used (PLLVD = 0 V).
PHSTR	94	I	The PHSTR pin has two functions. When the sync_phstr register is 0, a high on the PHSTR pin resets the NCO phase accumulator. When the sync_phstr register is 1, a PHSTR pin low-to-high transition sets the divided clock phase in external clock mode, and a high on the PHSTR pin resets the NCO phase accumulator. Internal pulldown
PLLGND	65		Ground return for internal PLL
PLLVDD	67		PLL supply voltage. When PLLVDD is 0 V, the PLL is disabled.
PLLLOCK	70	O	PLL lock status bit. In PLL clock mode, PLLLOCK is high when PLL is locked to the input clock. In external clock mode, PLLLOCK outputs the input rate clock.
QFLAG	98	I	Used in the interleaved data input mode: When the qflag register bit is 1, the QFLAG pin is used as an input to identify the interleaved data sequence. QFLAG high identifies the data as channel B. Pin can be left open when not used. Internal pulldown
RESETB	95	I	Resets the chip when low. Internal pullup
SCLK	29	I	Serial interface clock. Internal pulldown
SDENB	28	I	Active-low serial data enable, always an input to the DAC5686. Internal pulldown

Terminal Functions (continued)

TERMINAL NAME	NO.	I/O	DESCRIPTION
SDIO	30	I/O	Bidirectional serial-port data in the three-pin serial interface mode. Input-only serial data in the four-pin serial interface mode. Internal pulldown
SDO	31	O	High-impedance state (the pin is not used) in the three-pin serial interface mode. Serial-port output data in the four-pin serial interface mode.
SLEEP	96	I	Asynchronous hardware power-down input. Active high. Internal pulldown
TESTMODE	97	I	TESTMODE is DGND for the user.
TxENABLE	33	I	TxENABLE is used in interleaved mode. The rising edge of TxENABLE synchronizes the data of channels A and B. The first data after the rising edge of TxENABLE is treated as A data, while the next data is treated as B data and so on. In any mode, TxENABLE being low sets DAC outputs to midscale. Internal pulldown

ABSOLUTE MAXIMUM RATINGS

over operating free-air temperature range (unless otherwise noted) ⁽¹⁾

		UNIT
Supply voltage range	AVDD ⁽²⁾	–0.5 V to 4 V
	DVDD ⁽³⁾	–0.5 V to 2.3 V
	CLKVDD ⁽²⁾	–0.5 V to 4 V
	IOVDD ⁽²⁾	–0.5 V to 4 V
	PLLVDD ⁽²⁾	–0.5 V to 4 V
Voltage between AGND, DGND, CLKGND, PLLGND, and IOGND		–0.5 V to 0.5 V
Supply voltage range	AVDD to DVDD	–0.5 V to 2.6 V
	DA[15:0] ⁽³⁾	–0.5 V to IOVDD + 0.5 V
	DB[15:0] ⁽³⁾	–0.5 V to IOVDD + 0.5 V
	SLEEP ⁽³⁾	–0.5 V to IOVDD + 0.5 V
	CLK1, CLK2, CLK1C, CLK2C ⁽³⁾	–0.5 V to CLKVDD + 0.5 V
	RESETB ⁽³⁾	–0.5 V to IOVDD + 0.5 V
	LPF ⁽³⁾	–0.5 V to PLLVDD + 0.5 V
	IOUT1, IOUT2 ⁽²⁾	–1 V to AVDD + 0.5 V
	EXTIO, BIASJ ⁽²⁾	–0.5 V to AVDD + 0.5 V
EXTLO ⁽²⁾	–0.5 V to IOVDD + 0.5 V	
Peak input current (any input)		20 mA
Operating free-air temperature range, T _A : DAC5686I		–40C to 85C
Storage temperature range		–65C to 150C
Lead temperature 1,6 mm (1/16 inch) from the case for 10 seconds		260C

(1) Stresses beyond those listed under *Absolute Maximum Ratings* may cause permanent damage to the device. These are stress ratings only, and functional operation of the device at these or any other conditions beyond those indicated under *Recommended Operating Conditions* is not implied. Exposure to absolute-maximum-rated conditions for extended periods may affect device reliability.

(2) Measured with respect to AGND

(3) Measured with respect to DGND

ELECTRICAL CHARACTERISTICS (DC SPECIFICATIONS)⁽¹⁾

 over operating free-air temperature range, AVDD = 3.3 V, CLKVDD = 3.3 V, PLLVDD = 3.3 V, IOVDD = 3.3 V, DVDD = 1.8 V, IOUT_{FS} = 20 mA (unless otherwise noted)

PARAMETER		TEST CONDITIONS	MIN	TYP	MAX	UNIT
Resolution			16			
DC Accuracy⁽²⁾						
INL	Integral nonlinearity	1 LSB = IOUT _{FS} /2 ¹⁶ , T _{MIN} to T _{MAX}		12		LSB
DNL	Differential nonlinearity			1.84e-4		IOUT _{FS}
				9		LSB
				1.37e-4		IOUT _{FS}
Analog Output						
	Coarse gain linearity (INL)	LSB = 1/10 th of full scale		0.016		LSB
	Fine gain linearity (INL)			3		LSB
	Offset error	Mid-code offset		0.003		%FSR
	Gain error	Without internal reference		0.7		%FSR
		With internal reference		0.7		
	Gain mismatch	With internal reference, dual DAC, SSB mode	-2		2	%FSR
	Full-scale output current ⁽³⁾		2		20	mA
	Output compliance range ⁽⁴⁾	IOUT _{FS} = 20 mA	AVDD - 0.5		AVDD + 0.5	V
	Output resistance			300		kΩ
	Output capacitance			5		pF
Reference Output						
	Reference voltage		1.14	1.2	1.26	V
	Reference output current ⁽⁵⁾			100		nA
Reference Input						
V _{EXTIO}	Input voltage range		0.1		1.25	V
	Input resistance			1		MΩ
	Small-signal bandwidth			2.5		kHz
	Input capacitance			100		pF
Temperature Coefficients						
	Offset drift			3		ppm of FSR/C
	Gain drift	Without internal reference		15		ppm of FSR/C
		With internal reference		40		
	Reference voltage drift			25		ppm/C

(1) Specifications subject to change without notice.

(2) Measured differential across IOUTA1 and IOUTA2 or IOUTB1 and IOUTB2 with 25 Ω each to AVDD

 (3) Nominal full-scale current, IOUT_{FS}, equals 16x the IBIAS current.

(4) The upper limit of the output compliance is determined by the CMOS process. Exceeding this limit may result in transistor breakdown, resulting in reduced reliability of the DAC5686 device. The lower limit of the output compliance is determined by the load resistors and full-scale output current. Exceeding the upper limit adversely affects distortion performance and integral nonlinearity.

(5) Use an external buffer amplifier with high-impedance input to drive any external load.

ELECTRICAL CHARACTERISTICS (DC SPECIFICATIONS) (continued)

over operating free-air temperature range, AVDD = 3.3 V, CLKVDD = 3.3 V, PLLVDD = 3.3 V, IOVDD = 3.3 V, DVDD = 1.8 V, IOUT_{FS} = 20 mA (unless otherwise noted)

PARAMETER		TEST CONDITIONS	MIN	TYP	MAX	UNIT
Power Supply						
AVDD	Analog supply voltage		3	3.3	3.6	V
DVDD	Digital supply voltage		1.65	1.8	1.95	V
CLKVDD	Clock supply voltage		3	3.3	3.6	V
IOVDD	I/O supply voltage		1.65		3.6	V
PLLVDD	PLL supply voltage		3	3.3	3.6	V
I _{AVDD}	Analog supply current	Single (quad) DAC mode; including output current through load resistor, mode 7		30		mA
		Dual DAC mode; including output current through load resistor, mode 11			55	
I _{DVDD}	Digital supply current			242		mA
I _{CLKVDD}	Clock supply current	f _{DATA} = 125 MSPS, SSB mode, f _{DAC} = 500 MSPS, 40-MHz IF		10		mA
I _{PLLVDD}	PLL supply current			28		mA
I _{IOVDD}	IO supply current			< 3		mA
I _{AVDD}	Sleep mode, AVDD supply current	Sleep mode		1		mA
I _{DVDD}	Sleep mode, DVDD supply current			4		mA
I _{CLKVDD}	Sleep mode, CLKVDD supply current			2		mA
I _{PLLVDD}	Sleep mode, PLLVDD supply current			0.5		mA
I _{IOVDD}	Sleep mode, IOVDD supply current			0.25		mA
P _D	Power dissipation		Mode 1 ⁽⁶⁾ AVDD = 3.3 V, DVDD = 1.8 V		215	
		Mode 2 ⁽⁷⁾ AVDD = 3.3 V, DVDD = 1.8 V		495		
		Mode 5 ⁽⁸⁾ AVDD = 3.3 V, DVDD = 1.8 V		445		
		Mode 7 ⁽⁹⁾ AVDD = 3.3 V, DVDD = 1.8 V		754		
		Mode 9 ⁽¹⁰⁾ AVDD = 3.3 V, DVDD = 1.8 V		547		
		Mode 11 ⁽¹¹⁾ AVDD = 3.3 V, DVDD = 1.8 V		855	950	
APSR	Power supply rejection ratio		-0.2		0.2	%FSR/V
DPSR	Power supply rejection ratio		-0.2		0.2	%FSR/V

- (6) Mode 1: Dual DAC mode, fully bypassed, f_{DAC} = 160 MSPS, f_{OUT} = 20 MHz
- (7) Mode 2: Dual DAC mode, 2x interpolation, f_{DAC} = 320 MSPS, f_{OUT} = 20 MHz
- (8) Mode 5: Quadrature modulation mode, 4x interpolation, f_{DAC}/4 mixing, f_{DAC} = 320 MSPS, f_{OUT} = 100 MHz
- (9) Mode 7: Quadrature modulation mode, 4x interpolation, NCO running at 320 MHz, f_{DAC} = 320 MSPS, f_{OUT} = 100 MHz
- (10) Mode 9: SSB modulation mode, 4x interpolation, f_{DAC}/4 mixing, f_{DAC} = 320 MSPS, f_{OUT} = 100 MHz
- (11) Mode 11: SSB modulation mode, 4x interpolation, NCO running at 320 MHz, f_{OUT} = 100 MHz, maximum operating condition

ELECTRICAL CHARACTERISTICS (AC SPECIFICATIONS)⁽¹⁾

over operating free-air temperature range, AVDD = 3.3 V, CLKVDD = 3.3 V, PLLVDD = 0 V, IOVDD = 3.3 V, DVDD = 1.8 V, IOUT_{FS} = 20 mA, external clock mode, differential transformer-coupled output, 50-Ω doubly terminated load (unless otherwise noted)

PARAMETER		TEST CONDITIONS	MIN	TYP	MAX	UNIT
Analog Output						
f _{CLK}	Maximum output update rate		500			MSPS
t _{s(DAC)}	Output settling time to 0.1%	Mid-scale transition		12		ns
t _{pd}	Output propagation delay			2.5		ns
t _{r(IOUT)} ⁽²⁾	Output rise time 10% to 90%			2.5		ns
t _{f(IOUT)} ⁽²⁾	Output fall time 90% to 10%			2.5		ns
AC Performance—1:1 Impedance-Ratio Transformer						
SFDR	Spurious free dynamic range	First Nyquist zone < f _{DATA} /2 ⁽³⁾ , 4x interpolation, dual DAC mode, f _{DATA} = 52 MSPS, f _{OUT} = 14 MHz, T _A = 25C, IOVDD = 1.8 V		89		dBc
		First Nyquist zone < f _{DATA} /2 ⁽³⁾ , 4x interpolation, dual DAC mode, f _{DATA} = 160 MSPS, f _{OUT} = 20 MHz, full bypass, T _A = T _{MIN} to T _{MAX} and PLLVDD = 3.3 V for MIN, 25C for TYP, IOVDD = 1.8 V for TYP	68	79		
		First Nyquist zone < f _{DATA} /2 ⁽³⁾ , 2x interpolation, dual DAC mode, f _{DATA} = 160 MSPS, f _{OUT} = 41 MHz, T _A = 25C, IOVDD = 1.8 V		72		
		First Nyquist zone < f _{DATA} /2 ⁽³⁾ , 2x interpolation, dual DAC mode, f _{DATA} = 160 MSPS, f _{OUT} = 61 MHz, T _A = 25C, IOVDD = 1.8 V		68		
SNR	Signal-to-noise ratio	First Nyquist zone < f _{DATA} /2, f _{DATA} = 100 MSPS, f _{OUT} = 5 MHz, IOVDD = 1.8 V, f _{DAC} = 400 MSPS		80		dB
		First Nyquist zone < f _{DATA} /2, f _{DATA} = 78 MSPS, f _{OUT} = 15.6 MHz, 15.8 MHz, 16.2 MHz, 16.4 MHz, IOVDD = 1.8 V, f _{DAC} = 314 MSPS		72		
ACLR	Adjacent-channel power ratio	Single carrier W-CDMA with 3.84-MHz BW, 5-MHz spacing, centered at IF, TESTMODEL 1, 10 ms, f _{DATA} = 122.88 MSPS, baseband, dual DAC, 2x interpolation, f _{OUT} = 245 MSPS		72		dB
		Single carrier W-CDMA with 3.84-MHz BW, 5-MHz spacing, centered at IF, TESTMODEL 1, 10 ms, f _{DATA} = 76.8 MSPS, IF = 19.2 MHz, dual DAC, 2x interpolation, f _{OUT} = 153.6 MSPS		77		
		Single carrier W-CDMA with 3.84-MHz BW, 5-MHz spacing, centered at IF, TESTMODEL 1, 10 ms, f _{DATA} = 122.88 MSPS, IF = 30.72 MHz, dual DAC, 2x interpolation, f _{DAC} = 245 MSPS		76		
		Single carrier W-CDMA with 3.84-MHz BW, 5-MHz spacing, centered at IF, TESTMODEL 1, 10 ms, f _{DATA} = 61.44 MSPS, IF = 61.44 MHz, quad mode, f _{DAC} /4, 4x interpolation, f _{DAC} = 245 MSPS		73		
		Two-carrier W-CDMA with 3.84-MHz BW, 5-MHz spacing, centered at IF, TESTMODEL 1, 10 ms, f _{DATA} = 122.88 MSPS, IF = 30.72 MHz, dual DAC, 2x interpolation, f _{DAC} = 245 MSPS		72		
		Four-carrier W-CDMA with 3.84-MHz BW, 5-MHz spacing, centered at IF, TESTMODEL 1, 10 ms, f _{DATA} = 121.88 MSPS, complex IF - 30.72 MHz, quad mode, f _{DAC} /4, 4x interpolation, IF = 92.16 MHz		64		

(1) Specifications subject to change without notice

(2) Measured single-ended into 50-Ω load

(3) See the *Non-Harmonic Clock-Related Spurious Signals* section for information on spurious products out of band (> f_{DATA}/2).

ELECTRICAL CHARACTERISTICS (AC SPECIFICATIONS) (continued)

over operating free-air temperature range, AVDD = 3.3 V, CLKVDD = 3.3 V, PLLVDD = 0 V, IOVDD = 3.3 V, DVDD = 1.8 V, IOU_{TFS} = 20 mA, external clock mode, differential transformer-coupled output, 50-Ω doubly terminated load (unless otherwise noted)

PARAMETER		TEST CONDITIONS	MIN	TYP	MAX	UNIT
IMD3	Third-order two-tone intermodulation	f _{DATA} = 160 MSPS, f _{OUT} = 60.1 and 61.1 MHz, 2x interpolation, 320 MSPS, IOVDD = 1.8 V, each tone at –6 dBFS		74		dBc
		f _{DATA} = 100 MSPS, f _{OUT} = 15.1 and 16.1 MHz, 2x interpolation, 200 MSPS, IOVDD = 1.8 V, each tone at –6 dBFS		84		
IMD	Four-tone intermodulation	f _{DATA} = 100 MSPS, f _{OUT} = 15.6 MHz, 15.8 MHz, 16.2 MHz, 16.4 MHz, 4x interpolation, 400 MSPS, IOVDD = 1.8 V, each tone at –12 dBFS		85		dBc

ELECTRICAL CHARACTERISTICS (DIGITAL SPECIFICATIONS)⁽¹⁾

over operating free-air temperature range, AVDD = 3.3 V, CLKVDD = 3.3 V, PLLVDD = 3.3 V, IOVDD = 3.3 V, DVDD = 1.8 V, IOU_{TFS} = 20 mA (unless otherwise noted)

PARAMETER		TEST CONDITIONS	MIN	TYP	MAX	UNIT
CMOS Interface						
V _{IH}	High-level input voltage		2	3		V
V _{IL}	Low-level input voltage		0	0	0.8	V
I _{IH}	High-level input current		–40		40	A
I _{IL}	Low-level input current		–40		40	A
	Input capacitance			5		pF
V _{OH}	High-level output voltage, PLLLOCK, SDO, SDIO (I/O)	I _L = –100 A	IOVDD – 0.2			V
		I _L = –8 mA	0.8 × IOVDD			
V _{OL}	Low-level output voltage, PLLLOCK, SDO, SDIO (I/O)	I _L = 100 A			0.2	V
		I _L = 8 mA			0.22 × IOVDD	
PLL⁽²⁾						
	Input data rate supported		1		160	MSPS
	Phase noise	At 600-kHz offset, measured at DAC output, 25-MHz 0-dBFS tone, f _{DATA} = 125 MSPS, 4x interpolation		128		dBc/Hz
		At 6-MHz offset, measured at DAC output, 25-MHz 0-dBFS tone, f _{DATA} = 125 MSPS, 4x interpolation		151		
	VCO minimum frequency	PLL _{rng} = 00 (nominal)			120	MHz
	VCO maximum frequency	PLL _{rng} = 00 (nominal)	500			MHz
NCO						
	NCO clock (DAC update rate)				320	MHz
Serial Port Timing						
t _{su} (SDENB)	Setup time, SDENB to rising edge of SCLK		20			ns
t _{su} (SDIO)	Setup time, SDIO valid to rising edge of SCLK		10			ns
t _h (SDIO)	Hold time, SDIO valid to rising edge of SCLK		5			ns
t _{SCLK}	Period of SCLK		100			ns
t _{SCLKH}	High time of SCLK		40			ns
t _{SCLKL}	Low time of SCLK		40			ns

(1) Specifications subject to change without notice.

(2) See the *Non-Harmonic Clock-Related Spurious Signals* section for information on spurious products generated in PLL clock mode.

ELECTRICAL CHARACTERISTICS (DIGITAL SPECIFICATIONS) (continued)

over operating free-air temperature range, AVDD = 3.3 V, CLKVDD = 3.3 V, PLLVDD = 3.3 V, IOVDD = 3.3 V, DVDD = 1.8 V, IOU_{TFS} = 20 mA (unless otherwise noted)

PARAMETER	TEST CONDITIONS	MIN	TYP	MAX	UNIT		
t _d (DATA)	Data output delay after falling edge of SCLK		10		ns		
Parallel Data Input Timing, CLK1 Latching (PLL Mode and Dual Clock Mode)							
t _{su} (DATA)	Setup time, data valid to rising edge of CLK1	0.3	-0.4		ns		
t _h (DATA)	Hold time, data valid after rising edge of CLK1	1.2	0.6		ns		
Timing Parallel Data Input (External Clock Mode, CLK2 Input)							
t _{su} (DATA)	Setup time, DATA valid to rising edge of PLLLOCK	High-impedance load on PLLLOCK. Note that t _{su} increases with a lower-impedance load.		4.6	3	ns	
t _h (DATA)	Hold time, DATA valid after rising edge of PLLLOCK	High-impedance load on PLLLOCK. Note that t _h decreases (becomes more negative) with a lower-impedance load.		-0.8	-2.4	ns	
t _d (PLLlock)	Delay from CLK2 rising edge to PLLLOCK rising edge	High-impedance load on PLLLOCK. Note that PLLLOCK delay increases with a lower-impedance load.		2.5	4.2	6.5	ns

TYPICAL CHARACTERISTICS

INTEGRAL NONLINEARITY ERROR

vs

INPUT CODE

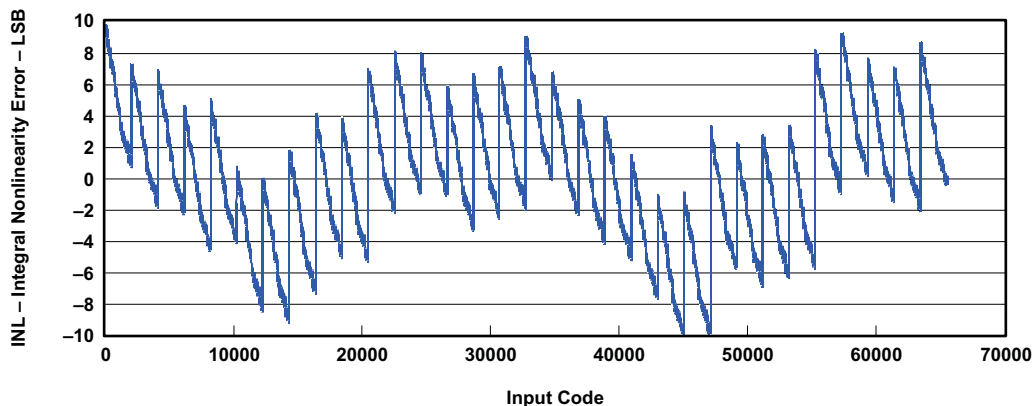

G001

Figure 1.

TYPICAL CHARACTERISTICS (continued)

DIFFERENTIAL NONLINEARITY ERROR
vs
INPUT CODE

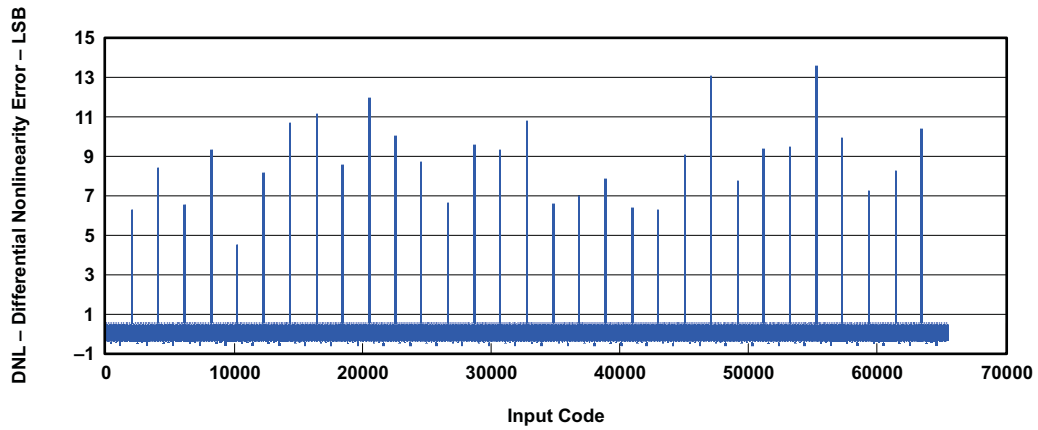

G002

Figure 2.

SINGLE-TONE SPECTRUM

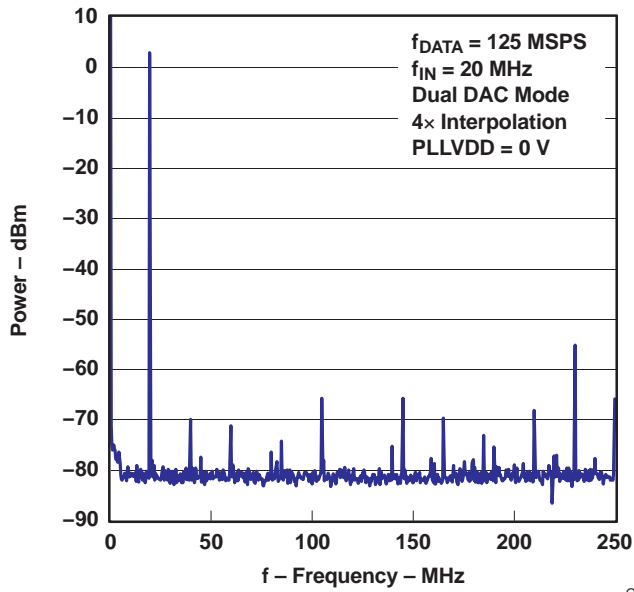

G003

Figure 3.

IN-BAND SPURIOUS-FREE DYNAMIC RANGE
vs
OUTPUT FREQUENCY

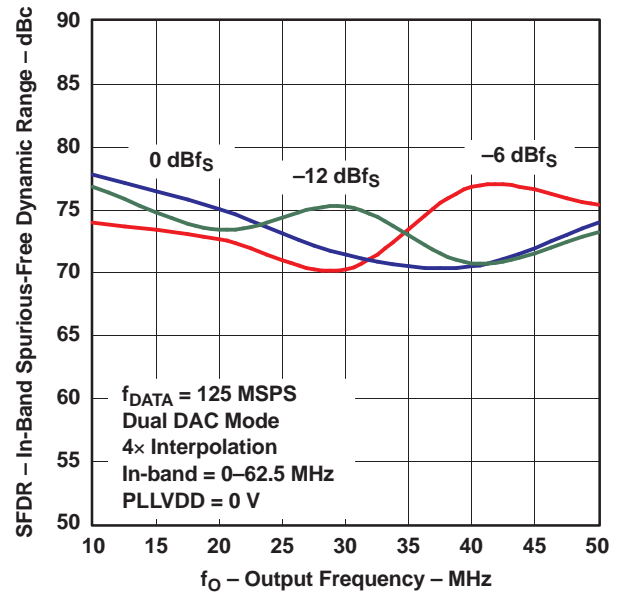

G004

Figure 4.

TYPICAL CHARACTERISTICS (continued)

OUT-OF-BAND SPURIOUS-FREE DYNAMIC RANGE vs OUTPUT FREQUENCY

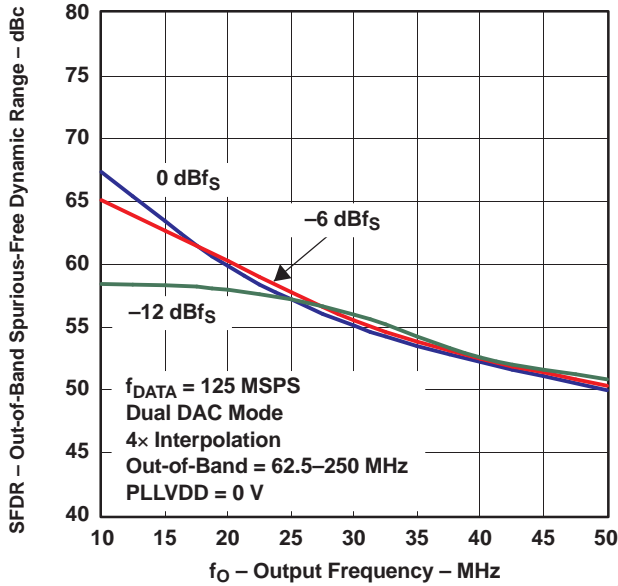

Figure 5.

G005

SINGLE-TONE SPECTRUM

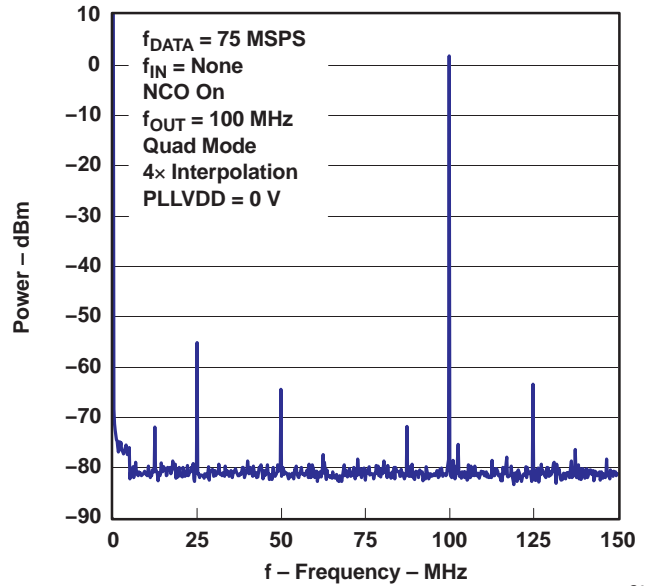

Figure 6.

G006

TWO-TONE IMD3 vs OUTPUT FREQUENCY

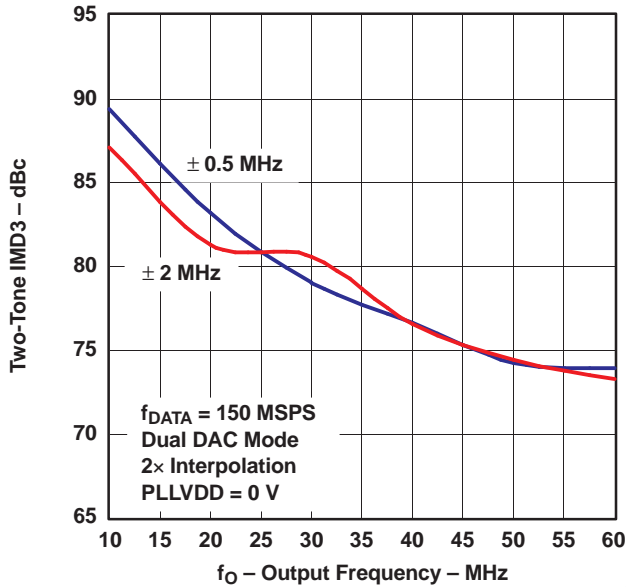

Figure 7.

G007

TWO-TONE IMD PERFORMANCE

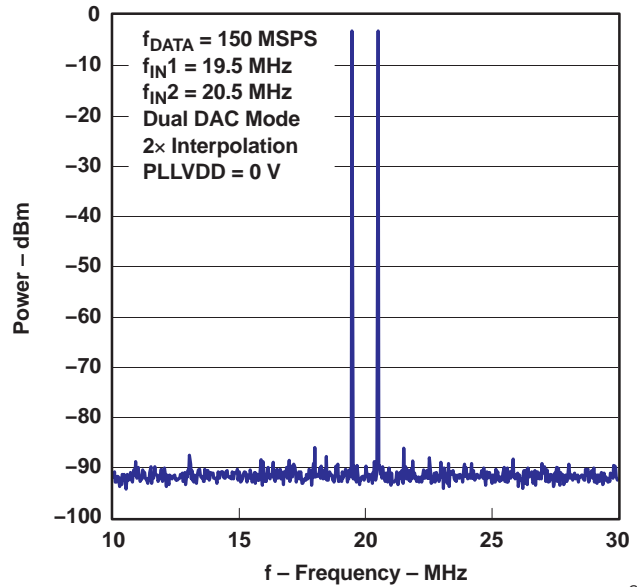

Figure 8.

G008

TYPICAL CHARACTERISTICS (continued)

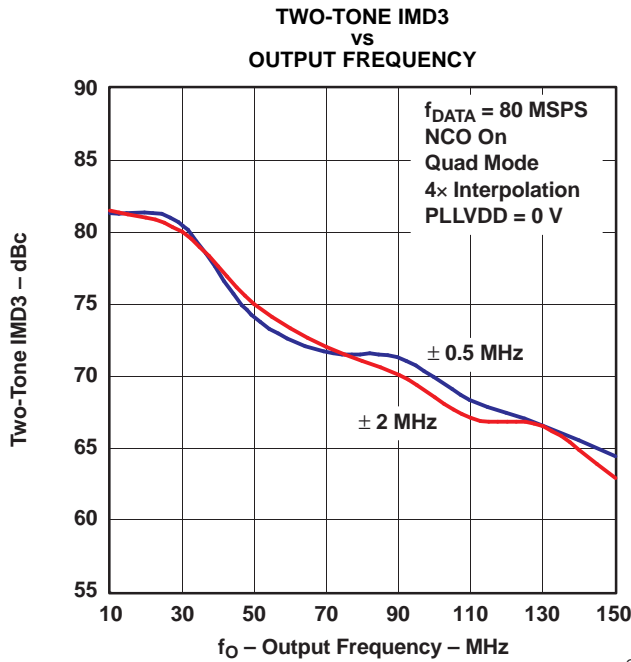

Figure 9.

G009

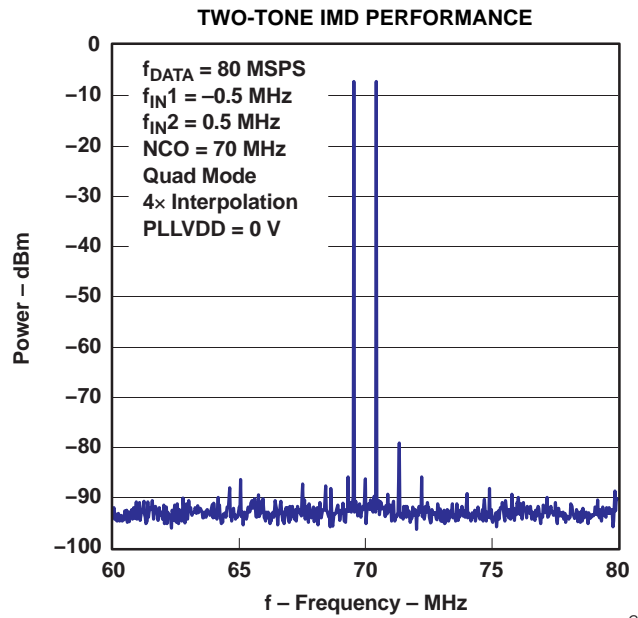

Figure 10.

G010

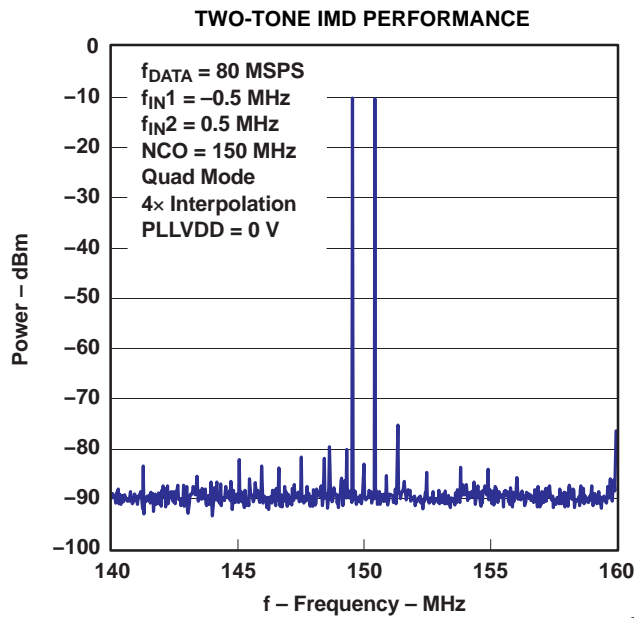

Figure 11.

G011

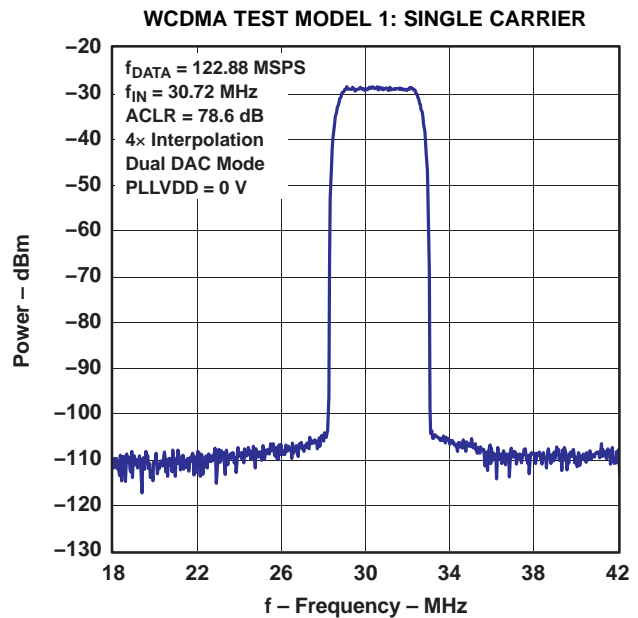

Figure 12.

G012

TYPICAL CHARACTERISTICS (continued)

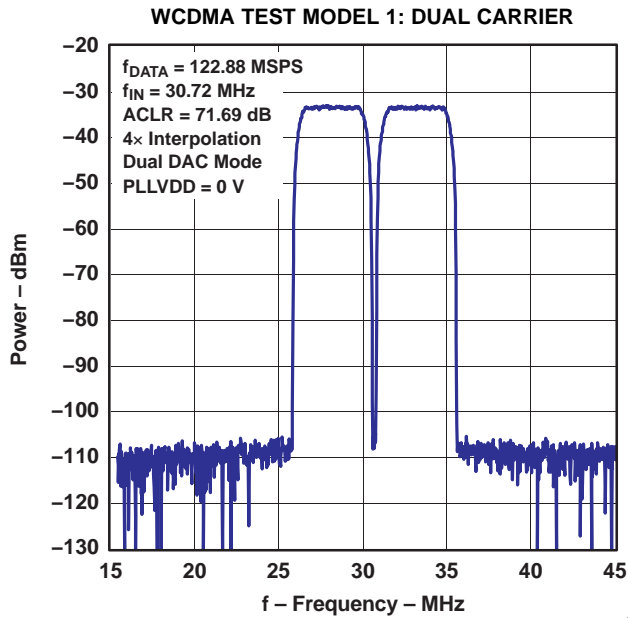

Figure 13.

G013

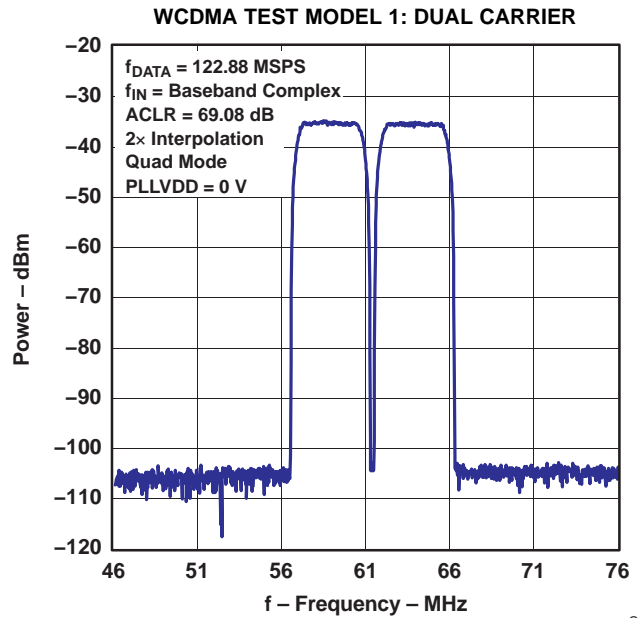

Figure 14.

G014

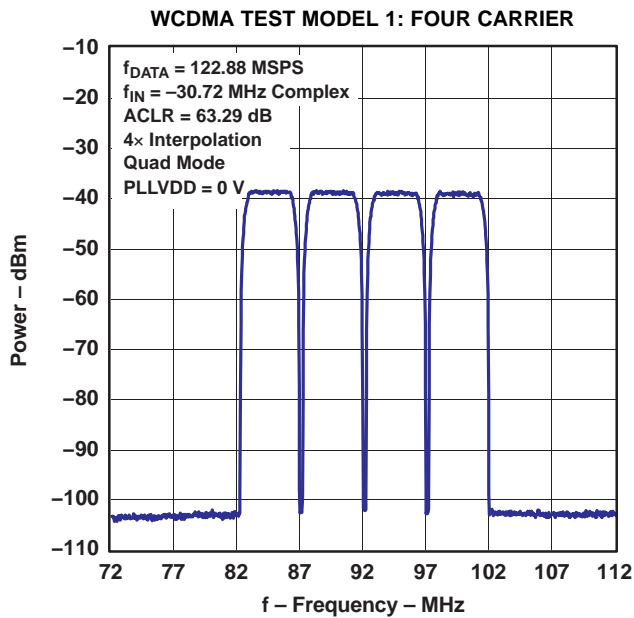

Figure 15.

G015

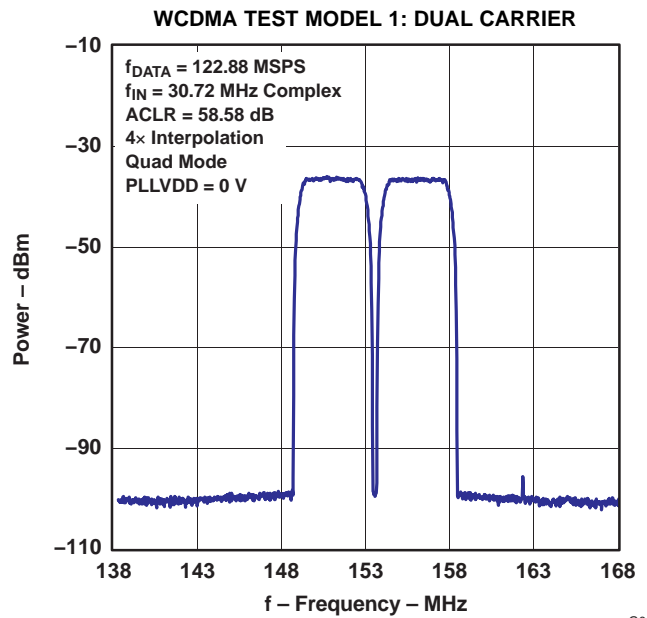
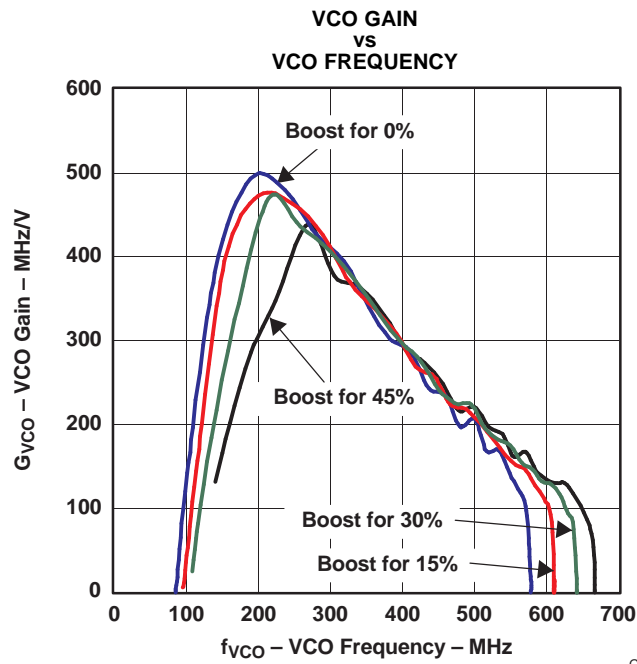

Figure 16.

G016

TYPICAL CHARACTERISTICS (continued)



DETAILED DESCRIPTION

Dual-Channel Mode

In dual-channel mode, interpolation filtering increases the DAC update rate, thereby reducing sinc/x rolloff and enabling relaxed analog post-filtering, and is useful for baseband I and Q modulation or two-channel low-IF signals. The dual-channel mode is set by **mode[1:0]** = 00 in the config_lsb register. Figure 18 shows the data path architecture in dual-channel mode. The A- and B-data paths, which are independent, consist of four cascaded half-band interpolation filters, followed by an optional inverse sinc filter. Interpolation filtering is selected as 2x, 4x, 8x, or 16x by **sel[1:0]** in the config_lsb register. Magnitude spectral responses of each filter are presented following in the section on digital filtering. Full bypass of all the interpolation filters is selected by **fbypass** in the config_lsb register. The inverse sinc filter is intended for use in single-sideband and quadrature modulation modes and is of limited benefit in dual-channel mode.

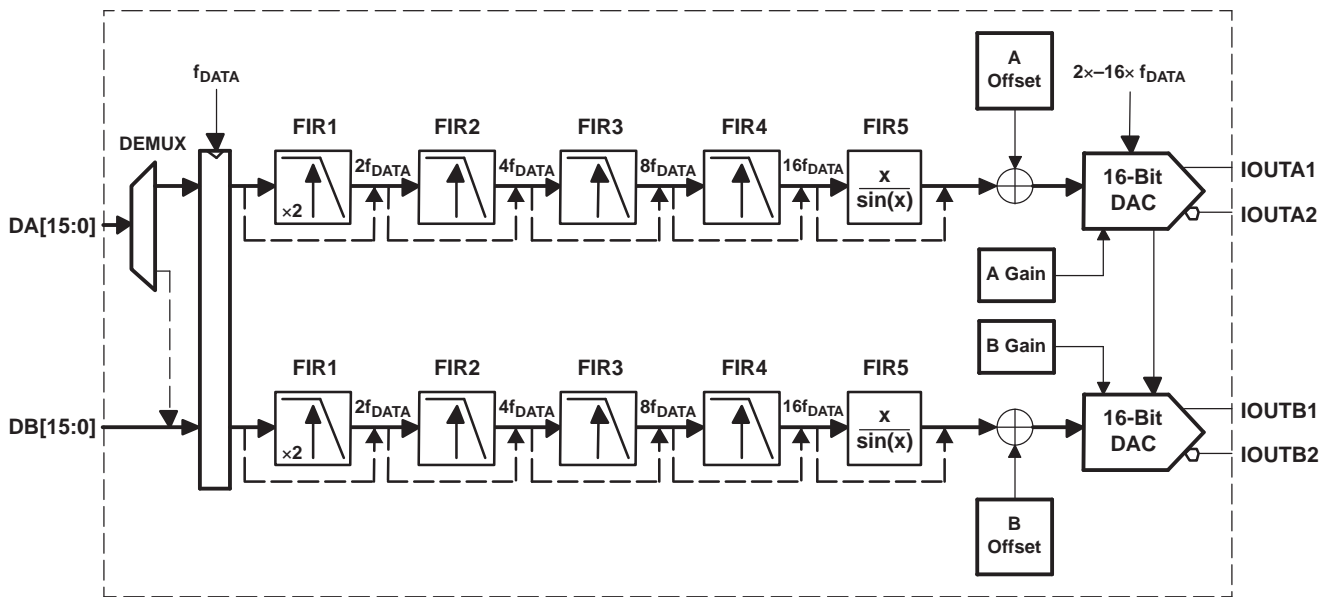

B0020-01

Figure 18. Data Path in Dual-Channel Mode

Single-Sideband Mode

Single-sideband (SSB) mode provides optimum interfacing to analog quadrature modulators. The SSB mode is selected by **mode[1:0]** = 01 in the config_lsb register. Figure 19 shows the data path architecture in single-sideband mode. Complex baseband I and Q are input to the DAC5686, which in turn performs a complex mix, resulting in Hilbert transform pairs at the outputs of the DAC5686's two DACs. NCO mixing frequencies are programmed through 32-bit **freq** (4 registers); 16-bit phase adjustments are programmed through **phase** (2 registers). The NCO operates at the DAC update rate; thus, increased amounts of interpolation allow for higher IFs. More details for the NCO are provided as follows. For mixing to $f_{\text{DAC}}/4$, DAC5686 provides a specific architecture that exploits the {... -1 0 1 0 ...} resultant streams from sin and cos; the NCO is shut off in this mode to conserve power. $f_{\text{DAC}}/4$ mix mode is implemented by deasserting **nco** in register config_msb while in single-sideband or quadrature modulation mode.

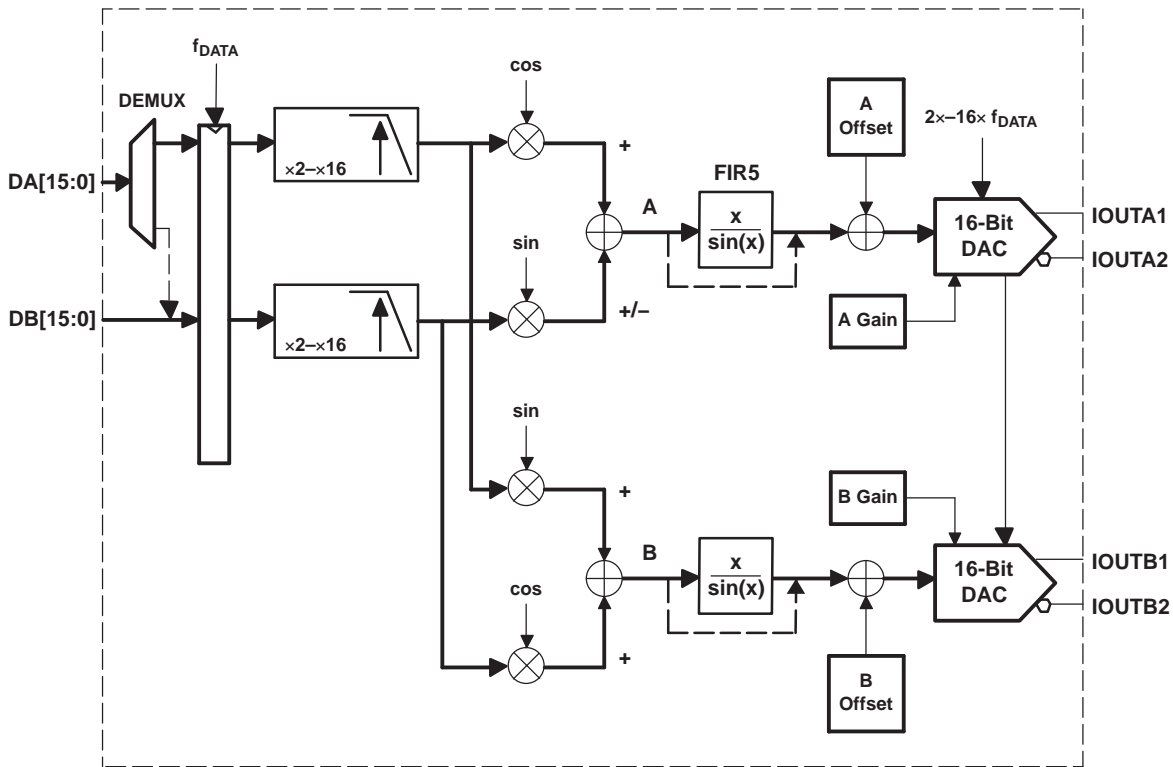

B0021-01

Figure 19. Data Path in SSB Mode

Figure 20 shows the DAC5686 interfaced to an RF quadrature modulator. The outputs of the complex mixer stage can be expressed as:

$$A(t) = I(t)\cos(\omega_c t) - Q(t)\sin(\omega_c t) = m(t)$$

$$B(t) = I(t)\sin(\omega_c t) + Q(t)\cos(\omega_c t) = m_h(t)$$

where $m(t)$ and $m_h(t)$ connote a Hilbert transform pair. Upper single-sideband up-conversion is achieved at the output of the analog quadrature modulator, whose output is expressed as:

$$IF(t) = I(t)\cos(\omega_c + \omega_{LO})t - Q(t)\sin(\omega_c + \omega_{LO})t$$

Flexibility is provided to the user by allowing for the selection of $-B(t)$ out, which results in lower-sideband up-conversion. This option is selected by **ssb** in the `config_msb` register. Figure 21 depicts the magnitude spectrum along the signal path during single-sideband up-conversion for real input. Further flexibility is provided to the user by allowing for the inverse of sin to be used in the complex mixer by programming **rspect** in the `config_usb` register. The four combinations of **rspect** and **ssb** allow the user to select one of four complex spectral bands to input to a quadrature modulator (see Figure 22).

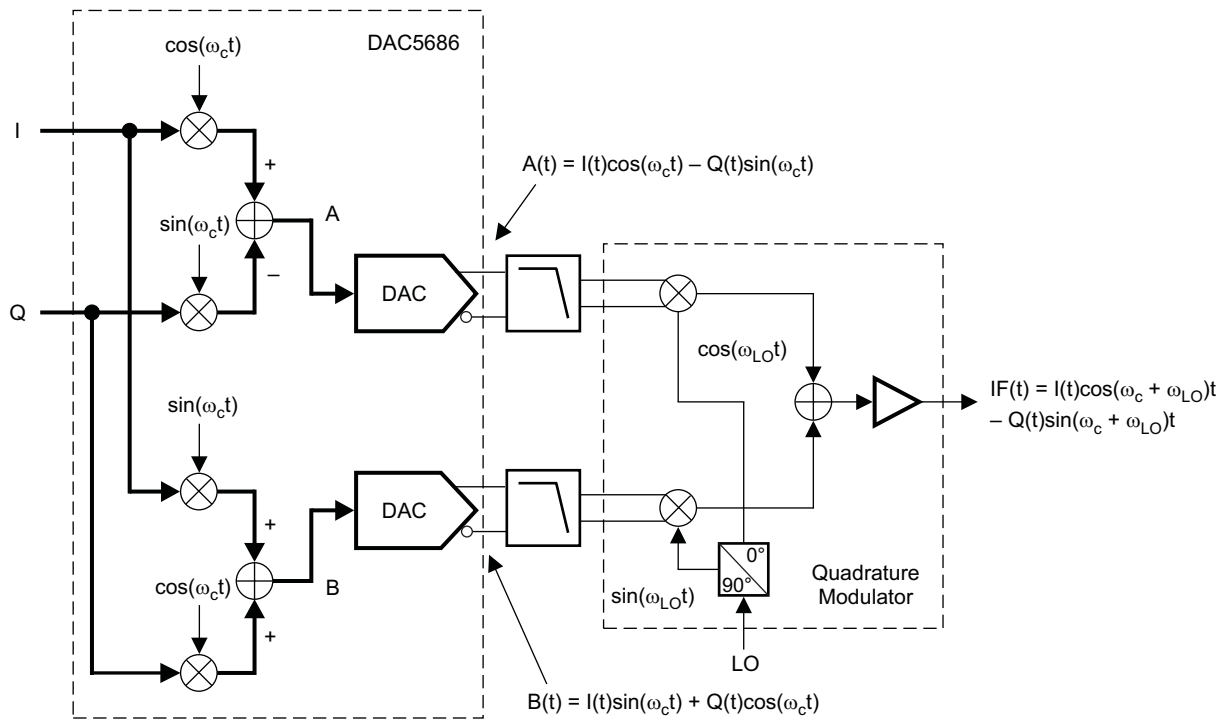

B0022–01

Figure 20. DAC5686 in SSB Mode With Quadrature Modulator

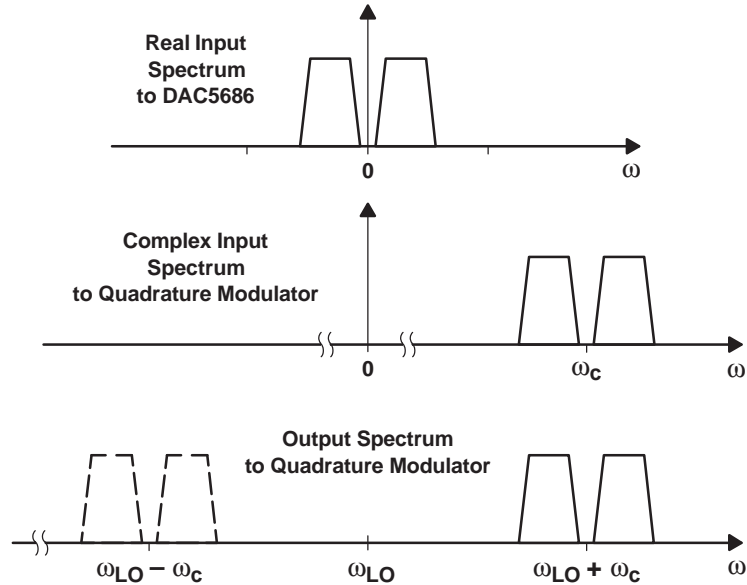

M0016-01

Figure 21. Spectrum After First and Second Up-Conversion for Real Input

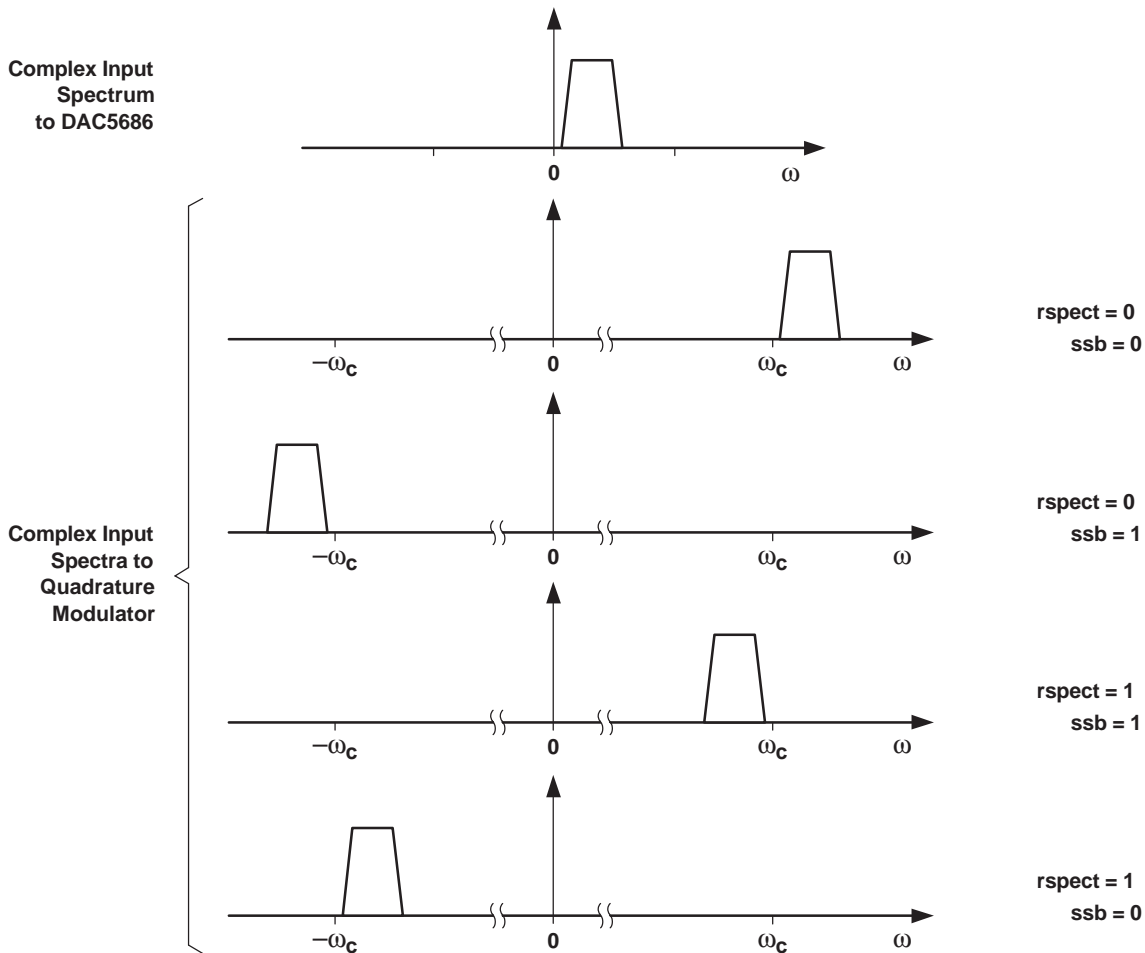

M0017-01

Figure 22. Complex Input Spectrum and DAC Output Spectra

To compensate for the sinc/x rolloff of the zero-order hold of the DACs, the DAC5686 provides an inverse sinc FIR, which provides high-frequency boost. The magnitude spectral response of this filter is presented in the *Digital Filters* section.

DAC Gain and Offset Control

Unmatched gains and offsets at the RF quadrature modulator result in unwanted sideband and local-oscillator feedthrough. Gain and offset imbalances between the two DACs are compensated for by programming **daca_gain**, **dacb_gain**, **daca_offset**, and **dacb_offset** in registers 0x0A through 0x0F (see the following register descriptions). The DAC gain value controls the full-scale output current. The DAC offset value adds a digital offset to the digital data before digital-to-analog conversion. Care must be taken when using the offset by restricting the dynamic range of the digital signal to prevent saturation when the offset value is added to the digital signal.

Dual-Channel Real Up-Conversion With NCO Set to $f_{\text{DAC}}/2$

The final interpolation filter in the DAC5686 can be converted from a low-pass filter to a high-pass filter by multiplying the interpolation filter output by the $(-1)^N = 1, -1, 1, -1, \dots$ sequence generated by the NCO in single-sideband mode. The high-pass filter selects a spectrally inverted image at $f_{\text{DAC}}/2 - f_{\text{IF}}$, where f_{IF} is the center frequency of the input spectrum. Note that in this mode f_{DAC} is limited by the 320-MHz maximum frequency for NCO operation.

The output of the mixer for the Nth sample is

$$A_{out}(N) = A_{in}(N)\cos(2\pi(Nf + f_0)/f_{DAC} + \phi) - B_{in}(N)\sin(2\pi(Nf + f_0)/f_{DAC} + \phi)$$

$$B_{out}(N) = A_{in}(N)\sin(2\pi(Nf + f_0)/f_{DAC} + \phi) + B_{in}(N)\cos(2\pi(Nf + f_0)/f_{DAC} + \phi)$$

where $f = \mathbf{freq} \times f_{DAC}/2^{32}$ and $\phi = \mathbf{phase} \times \pi/2^{15}$ and f_0 is the initial value of the NCO accumulator. When $f = f_{DAC}/2$, $f_0 = 0$, and $\phi = 0$, the sine term is 0 and the equations simplify to

$$A_{out}(N) = A_{in}(N) \times (-1)^N$$

$$B_{out}(N) = B_{in}(N) \times (-1)^N$$

resulting in two independent, real up-conversion paths.

It is essential that the NCO accumulator initial value $f_0 = 0$ to eliminate the cross-terms between the A and B channels. The accumulator is reset to 0 when the NCO is running by raising the PHSTR pin to IOVDD (when **sync_phstr** is set to 0). Note that the accumulator remains at 0 until the PHSTR pin is lowered to GND. The following steps ensure that the accumulator does not have a non-zero starting value:

1. Program the frequency register to 2^{31} .
2. Enable the NCO by asserting register bit **nco** in **config_msb**.
3. Raise PHSTR to IOVDD.
4. Lower PHSTR to GND.

Quadrature Modulation Mode

In quadrature modulation mode, on-chip mixing of complex I and Q inputs provides the final baseband-to-IF up-conversion. Quadrature modulation mode is selected by **mode[1:0] = 10** in the **config_lsb** register. [Figure 23](#) shows the data path architecture in quadrature modulation mode. Complex baseband I and Q from the ASIC/FPGA are input to the DAC5686, which in turn quadrature modulates I and Q to produce the final IF single-sideband spectrum. DAC A is held constant, while DAC B presents the DAC5686 quadrature modulator mode output.

NCO mixing frequencies are programmed through 32-bit **freq** (4 registers); 16-bit phase adjustments are programmed through **phase** (2 registers). The NCO operates at the DAC update rate; thus, increased amounts of interpolation allow for higher IFs. More details for the NCO are provided in the NCO section. For mixing to $f_{DAC}/4$, the DAC5686 provides a specific architecture that exploits the $\{\dots -1\ 0\ 1\ 0\ \dots\}$ resultant streams from sin and cos; the NCO is shut off in this mode to conserve power. The $f_{DAC}/4$ mix mode is implemented by deasserting **nco** in register **config_msb** while in single-sideband or quadrature modulation mode.

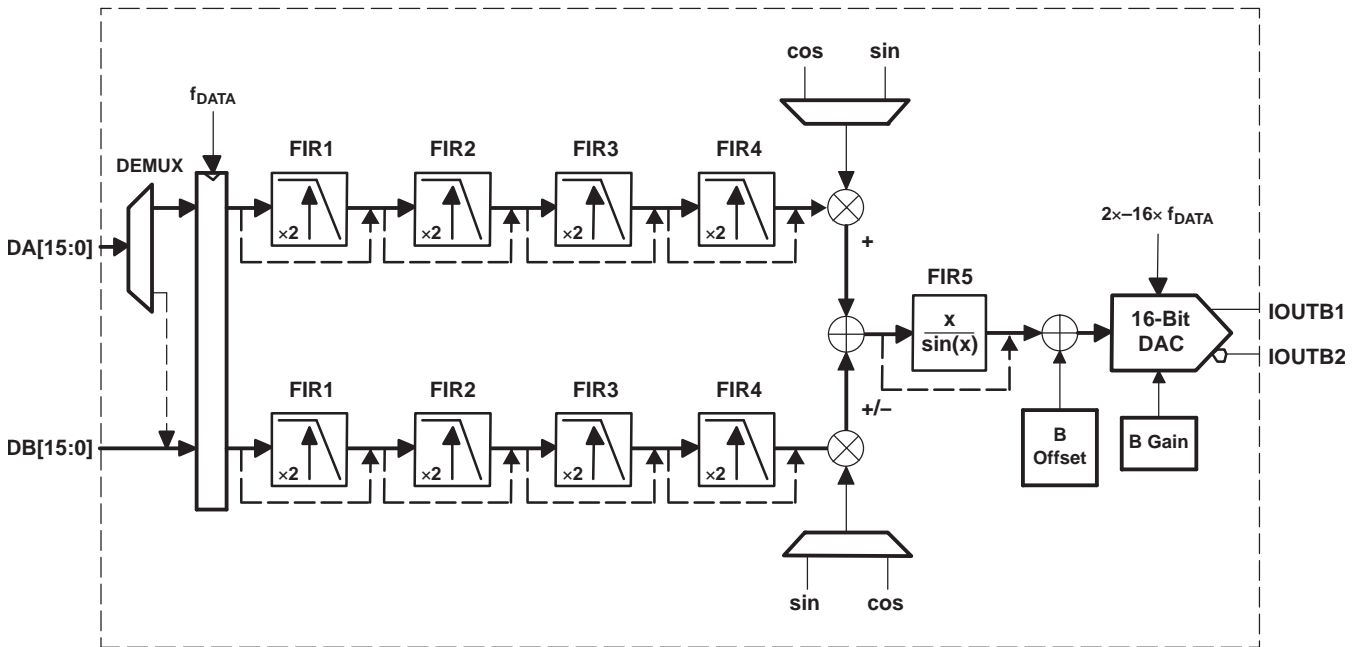

B0023-01

Figure 23. Data Path in Quadrature Modulation Mode

In quadrature modulation mode, only one output from the complex mixer stage is routed to the B DAC. The output can be expressed as:

$$B(t) = I(t)\sin(\omega_c t) + Q(t)\cos(\omega_c t)$$

or

$$B(t) = I(t)\cos(\omega_c t) - Q(t)\sin(\omega_c t)$$

Single-sideband up-conversion is achieved when I and Q are Hilbert transform pairs. Upper- or lower-sideband up-conversion is selected by **ssb** in the **config_msb** register, which selects the output from the mixer stage that is routed out.

The offset and gain features for the B DAC, as previously described, are functional in the quadrature mode.

Serial Interface

The serial port of the DAC5686 is a flexible serial interface that communicates with industry-standard microprocessors and microcontrollers. The interface provides read/write access to all registers used to define the operating modes of the DAC5686. It is compatible with most synchronous transfer formats and can be configured as a 3- or 4-pin interface by **sif4** in register **config_msb**. In both configurations, **SCLK** is the serial-interface input clock and **SDENB** is the serial-interface enable. For the 3-pin configuration, **SDIO** is a bidirectional pin for both data-in and data-out. For the 4-pin configuration, **SDIO** is data-in only and **SDO** is data-out only.

Each read/write operation is framed by signal **SDENB** (serial data enable bar) asserted low for 2 to 5 bytes, depending on the data length to be transferred (1–4 bytes). The first frame byte is the instruction cycle, which identifies the following data transfer cycle as read or write, how many bytes to transfer, and the address to/from which to transfer the data. Table 1 indicates the function of each bit in the instruction cycle and is followed by a detailed description of each bit. Frame bytes 2 through 5 comprise the data to be transferred.

Table 1. Instruction Byte of the Serial Interface

	MSB							LSB
Bit	7	6	5	4	3	2	1	0

Table 1. Instruction Byte of the Serial Interface (continued)

MSB					LSB			
Description	R/ \overline{W}	N1	N0	–	A3	A2	A1	A0

R/ \overline{W} : Identifies the following data transfer cycle as a read or write operation. A high indicates a read operation from the DAC5686 and a low indicates a write operation to the DAC5686.

N[1:0]: Identifies the number of data bytes to be transferred per [Table 2](#). Data is transferred MSB-first.

Table 2. Number of Transferred Bytes Within One Communication Frame

N1	N0	DESCRIPTION
0	0	Transfer 1 byte
0	1	Transfer 2 bytes
1	0	Transfer 3 bytes
1	1	Transfer 4 bytes

A4: Unused

A[3:0]: Identifies the address of the register to be accessed during the read or write operation. For multibyte transfers, this address is the starting address and the address decrements. Note that the address is written to the DAC5686 MSB-first.

Serial-Port Timing Diagrams

[Figure 24](#) shows the serial-interface timing diagram for a DAC5686 write operation. **SCLK** is the serial-interface clock input to the DAC5686. Serial data enable **SDENB** is an active-low input to the DAC5686. **SDIO** is serial data-in. Input data to the DAC5686 is clocked on the rising edges of **SCLK**.

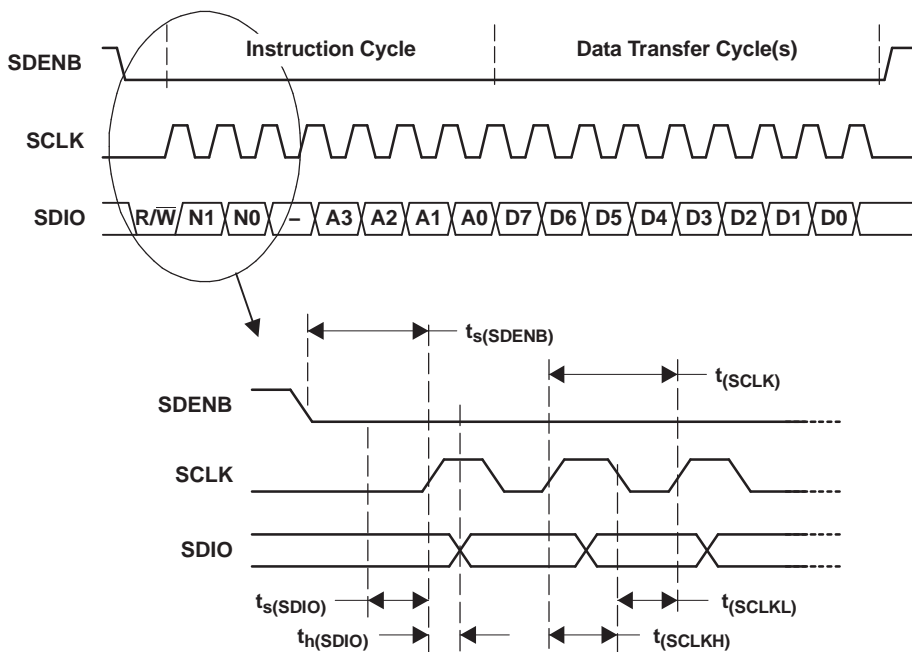

T0037-01

Figure 24. Serial-Interface Write Timing Diagram

[Figure 25](#) shows the serial-interface timing diagram for a DAC5686 read operation. **SCLK** is the serial-interface

clock input to the DAC5686. Serial data enable **SDENB** is an active-low input to the DAC5686. **SDIO** is serial data-in during the instruction cycle. In the 3-pin configuration, **SDIO** is data-out from the DAC5686 during the data transfer cycle(s), while **SDO** is in a high-impedance state. In the 4-pin configuration, **SDO** is data-out from the DAC5686 during the data transfer cycle(s). **SDO** is never placed in the high-impedance state in the four-pin configuration.

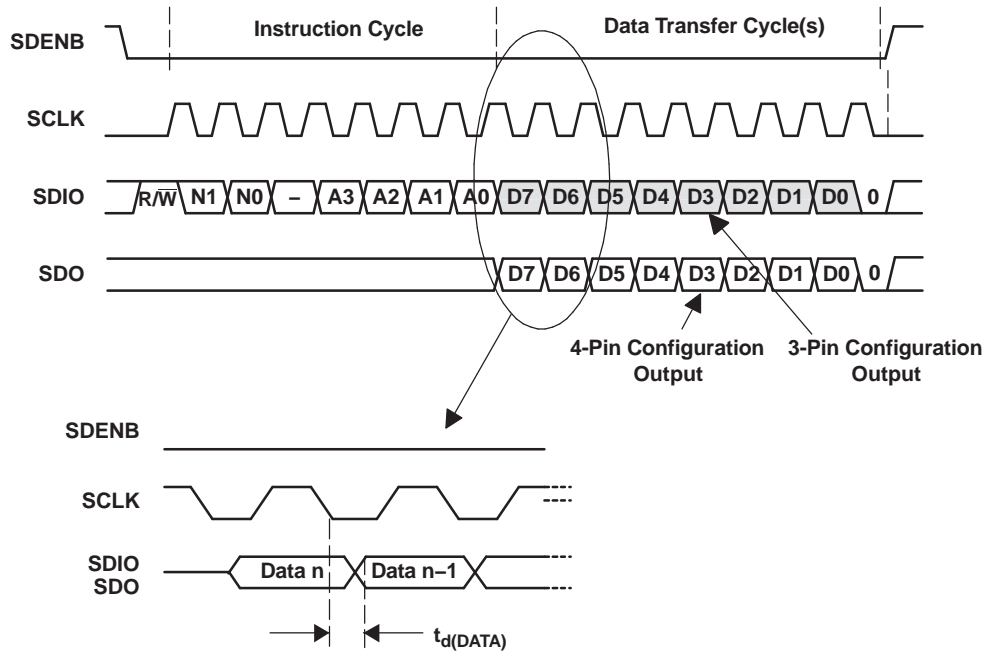

T0038-01

Figure 25. Serial-Interface Read Timing Diagram

Clock Generation

In the DAC5686, the internal clocks (1x, 2x, 4x, 8x, and 16x, as needed) for the logic, FIR interpolation filters, and DAC are derived from a clock at either the input data rate using an internal PLL (PLL clock mode) or the DAC output sample rate (external clock mode). Power for the internal PLL blocks (PLLVDV and PLLGND) is separate from power for the other clock generation blocks (CLKVDD and CLKGND), thus minimizing phase noise within the PLL.

The DAC5686 has three clock modes for generating the internal clocks (1x, 2x, 4x, 8x, and 16x, as needed) for the logic, FIR interpolation filters, and DACs. The clock mode is set using the PLLVDV pin and **dual_clk** in register **config_usb**. A block diagram for the clock generation circuit is shown in [Figure 27](#).

1. PLLVDV = 0 V and **dual_clk** = 0: EXTERNAL CLOCK MODE

In EXTERNAL CLOCK MODE, the user provides a clock signal at the DAC output sample rate through CLK2/CLK2C. CLK1/CLK1C and the internal PLL are not used, so the LPF circuit is not applicable. The input data rate clock and interpolation rate are selected by the registers **sel[1:0]**, and are output through the PLLLOCK pin. It is common to use the PLLLOCK clock to drive the chip that sends the data to the DAC; otherwise, there is phase ambiguity regarding how the DAC divides down to the input sample rate clock and an external clock divider divides down. (For a divide-by-N, there are N possible phases.) The phase ambiguity can also be solved by using PHSTR pin with a synchronization signal.

2. PLLVDV = 3.3 V (**dual_clk** can be 0 or 1 and is ignored): PLL CLOCK MODE

Power for the internal PLL blocks (PLLVDV and PLLGND) is separate from power for the other clock generation blocks (CLKVDD and CLKGND), thus minimizing PLL phase noise.

In PLL CLOCK MODE, the DAC is driven at the input sample rate (unless the data is multiplexed) through CLK1/CLK1C. CLK2/CLK2C is not used. In this case, there is no phase ambiguity on the clock. The DAC generates the higher-speed DAC sample-rate clock using an internal PLL/VCO. In PLL clock mode, the user provides a differential external reference clock on CLK1/CLK1C.

A type-4 phase-frequency detector (PFD) in the internal PLL compares this reference clock to a feedback clock and drives the PLL to maintain synchronization between the two clocks. The feedback clock is generated by dividing the VCO output by 1x, 2x, 4x, or 8x as selected by the prescaler (**div[1:0]**). The output of the prescaler is the DAC sample rate clock and is divided down to generate clocks at ÷2, ÷4, ÷8, and ÷16. The feedback clock is selected by the registers **sel[1:0]**, and then is fed back to the PFD for synchronization to the input clock. Because the feedback clock is also used for the data input rate, the interpolation rate of the DAC5686 is the ratio of DAC output clock to the feedback clock. The PLLLOCK pin is an output that indicates when the PLL has achieved lock. An external RC low-pass PLL filter is provided by the user at pin LPF. See the low-pass filter section for filter-setting calculations. This is the only mode where the LPF filter applies.

Use of the internal PLL/VCO generally results in higher phase noise than if an externally generated DAC clock is used. At low frequencies, such as baseband signals, use of the internal PLL/VCO likely has a minimal effect on signal quality. For higher IF frequencies, such as in single sideband or quadrature modulation mode, the PLL/VCO phase noise can result in degradation of the signal. Note that most of the DAC5686 plots and typical specifications are in external clock mode (PLLVD = 0). Use of the DAC5686 PLL/VCO also can result in higher out-of-band spurious signals (see the *Non-Harmonic Clock-Related Spurious Signals* section).

3. PLLVD = 0 V and **dual_clk** = 1: DUAL CLOCK MODE

In DUAL CLOCK MODE, the DAC is driven at the DAC sample rate through CLK2/CLK2C and at the input data rate through CLK1/CLK1C. The DUAL CLOCK MODE has the advantage of a clean external clock for DAC sampling without the phase ambiguity. The edges of CLK1 and CLK2 must be aligned to within t_{align} (See Figure 26), defined as

$$t_{align} = \frac{1}{2f_{CLK2}} - 0.5 \text{ ns}$$

where f_{CLK2} is the clock frequency of CLK2. For example, $t_{align} = 0.5 \text{ ns}$ at $f_{CLK2} = 500 \text{ MHz}$ and 1.5 ns at $f_{CLK2} = 250 \text{ MHz}$.

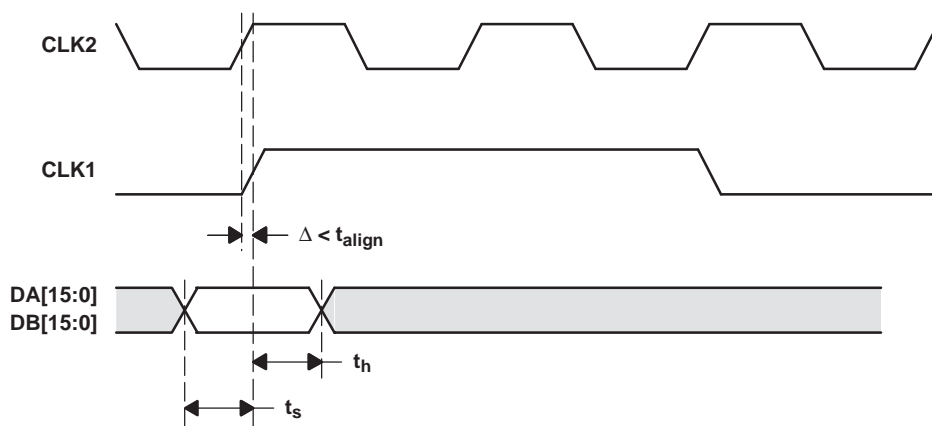

Figure 26. DAC and Data Clock Mode

The CDC7005 from Texas Instruments is recommended for providing phase-aligned clocks at different frequencies for this application.

Table 3 provides a summary of the clock configurations with corresponding data rate ranges.

Table 3. Clock-Mode Configuration (continued)

CLOCK MODE	PLLVD	DIV[1:0]	SEL[1:0]	DATA RATE (MSPS)	PLLLOCK PIN FUNCTION
Non-interleaved input data; internal PLL on; DA[15:0] data rate matches DB[15:0] data rate.					
Internal 2x	3.3 V	00	00	125 to 160	Internal PLL lock indicator
Internal 2x	3.3 V	01	00	62.5 to 125	Internal PLL lock indicator
Internal 2x	3.3 V	10	00	31.25 to 62.5	Internal PLL lock indicator
Internal 2x	3.3 V	11	00	15.63 to 31.25	Internal PLL lock indicator
Internal 4x	3.3 V	00	01	62.5 to 125	Internal PLL lock indicator
Internal 4x	3.3 V	01	01	31.25 to 62.5	Internal PLL lock indicator
Internal 4x	3.3 V	10	01	15.63 to 31.25	Internal PLL lock indicator
Internal 4x	3.3 V	11	01	7.8125 to 15.625	Internal PLL lock indicator
Internal 8x	3.3 V	00	10	31.25 to 62.5	Internal PLL lock indicator
Internal 8x	3.3 V	01	10	15.63 to 31.25	Internal PLL lock indicator
Internal 8x	3.3 V	10	10	7.8125 to 15.625	Internal PLL lock indicator
Internal 8x	3.3 V	11	10	3.9 to 7.8125	Internal PLL lock indicator
Internal 16x	3.3 V	00	11	15.625 to 31.25	Internal PLL lock indicator
Internal 16x	3.3 V	01	11	7.8125 to 15.625	Internal PLL lock indicator
Internal 16x	3.3 V	10	11	3.9062 to 7.8125	Internal PLL lock indicator
Interleaved input data on the DA[15:0] input pins; internal PLL on					
Internal 2x	3.3 V	00	00	Not recommended	Internal PLL lock indicator
Internal 2x	3.3 V	01	00	62.5 to 80	Internal PLL lock indicator
Internal 2x	3.3 V	10	00	31.25 to 62.5	Internal PLL lock indicator
Internal 2x	3.3 V	11	00	15.625 to 31.25	Internal PLL lock indicator
Internal 4x	3.3 V	00	01	62.5 to 80	Internal PLL lock indicator
Internal 4x	3.3 V	01	01	31.25 to 62.5	Internal PLL lock indicator
Internal 4x	3.3 V	10	01	15.625 to 31.25	Internal PLL lock indicator
Internal 4x	3.3 V	11	01	7.8125 to 15.625	Internal PLL lock indicator
Internal 8x	3.3 V	00	10	31.25 to 62.5	Internal PLL lock indicator
Internal 8x	3.3 V	01	10	15.625 to 31.25	Internal PLL lock indicator
Internal 8x	3.3 V	10	10	7.8125 to 15.625	Internal PLL lock indicator
Internal 8x	3.3 V	11	10	3.9062 to 7.8125	Internal PLL lock indicator
Internal 16x	3.3 V	00	11	15.625 to 31.25	Internal PLL lock indicator
Internal 16x	3.3 V	01	11	7.8125 to 15.625	Internal PLL lock indicator
Internal 16x	3.3 V	10	11	3.9062 to 7.8125	Internal PLL lock indicator
Internal 16x	3.3 V	11	11	1.9531 to 3.9062	Internal PLL lock indicator

Non-Harmonic Clock-Related Spurious Signals

In interpolating DACs, imperfect isolation between the digital and DAC clock circuits generates spurious signals at frequencies related to the DAC clock rate. The digital interpolation filters in these DACs run at sub-harmonic frequencies of the output rate clock, where these frequencies are $f_{DAC}/2^N$, $N = 1-4$. For example, for 2x interpolation there is only one interpolation filter running at $f_{DAC}/2$; for 4x interpolation, on the other hand, there are two interpolation filters running at $f_{DAC}/2$ and $f_{DAC}/4$. These lower-speed clocks for the interpolation filter mix with the DAC clock circuit and create spurious images of the wanted signal and second Nyquist-zone image at offsets of $f_{DAC}/2^N$.

The location of these spurious signals is determined by whether the DAC5686 output is used as a complex signal to be feed to an analog quadrature modulator or as a real IF signal. [Figure 28\(a\)](#) shows the location of the largest spurious signals for $f_{DAC} = 500$ MSPS and 4x interpolation for a complex output signal. At the output of the analog quadrature modulator, the spurious signals with negative frequencies appear on the opposite sideband from the wanted signal. The closest spurious signal results from the wanted signal mixing with the $f_{DAC}/4$ interpolation-filter clock, which in this example is 125 MHz from the wanted signal for all IF frequencies.

Figure 28(b) shows the location of the largest spurious signals for $f_{DAC} = 500$ MSPS and 4x interpolation for a real output signal. With a real output signal, there is no distinction between negative and positive frequencies, and therefore the signals that appear at negative frequencies with a complex signal potentially fall near the wanted signal. In particular, at IFs near $f_{DAC}/8$, $f_{DAC}/4$, and $f_{DAC} \times 3/4$ (62.5 MHz, 125 MHz and 187.5 MHz in this example) the mixing effect results in spurious signals falling near the wanted signal, which may present a problem depending on the system application. For a frequency-symmetric signal (such as a single WCDMA or CDMA carrier), operating at exactly $f_{DAC}/8$, $f_{DAC}/4$ and $f_{DAC} \times 3/4$, the spurious signal falls completely inside the wanted signal, which produces a clean spectrum but may result in degradation of the signal quality.

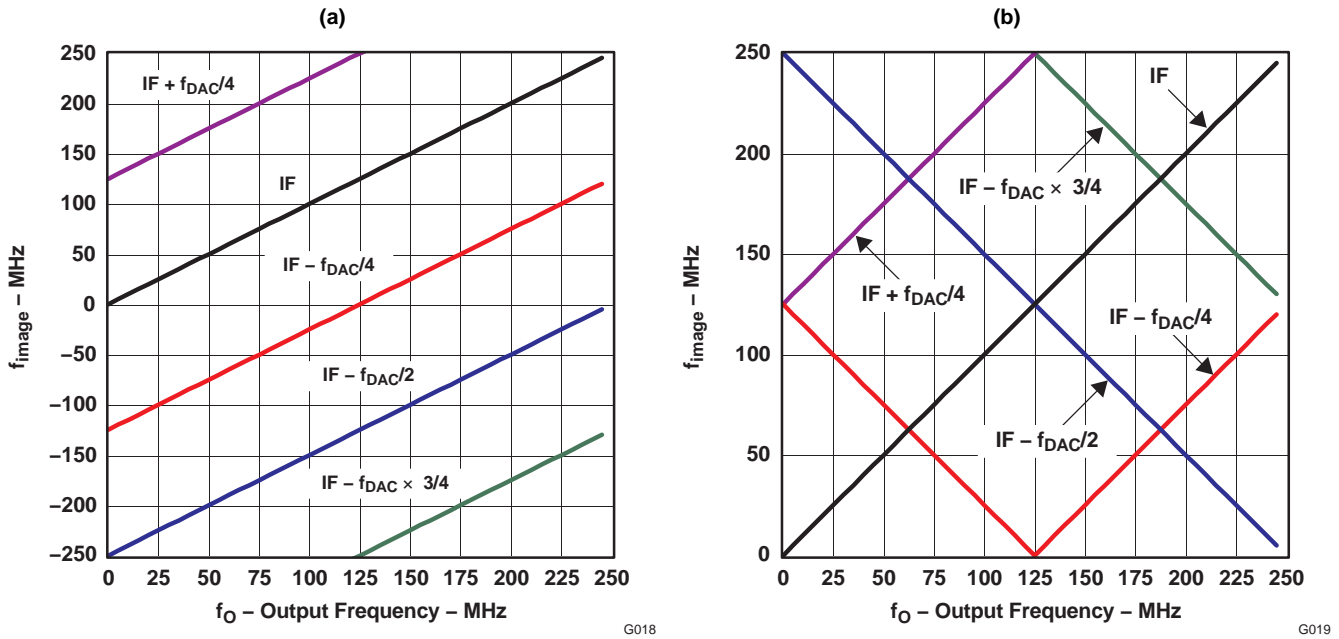

Figure 28. Spurious Frequency vs IF

The offset between wanted and spurious signals is maximized at low IFs ($< f_{DAC}/8$) and at $f_{DAC} \times 3/16$, $f_{DAC} \times 5/16$ and $f_{DAC} \times 7/16$. For example, with $f_{DATA} = 122.88$ MSPS and 4x interpolation, operating with $IF = f_{DAC} \times 5/16 = 153.6$ MHz results in spurious signals at offsets of 60 MHz from the wanted signal.

Figure 29(a) shows the amplitude of each spurious signal as a function of IF in external-clock mode (CLK2 input). The dominant spurious signal is $IF - f_{DAC}/2$. The amplitudes of the $IF + f_{DAC}/4$ and $IF - f_{DAC}/4$ are the next-highest spurious signals and are approximately at the same amplitude. Finally, at IF frequencies greater than 100 MHz, small spurious signals at $IF - f_{DAC}/8$ and $IF - f_{DAC} \times 3/4$ are measurable.

Figure 29(b) shows the amplitude of each spurious signal as a function of IF in PLL clock mode (CLK1 input). Generating the DAC clock with the onboard PLL/VCO increases the $IF - f_{DAC}/2$ by 10 dB and the amplitude of the $IF - f_{DAC}/4$ and $IF - f_{DAC} \times 3/4$ by 25 dB compared to the external-clock mode. The $IF - f_{DAC}/8$ spurs are the same as in the external-clock mode.

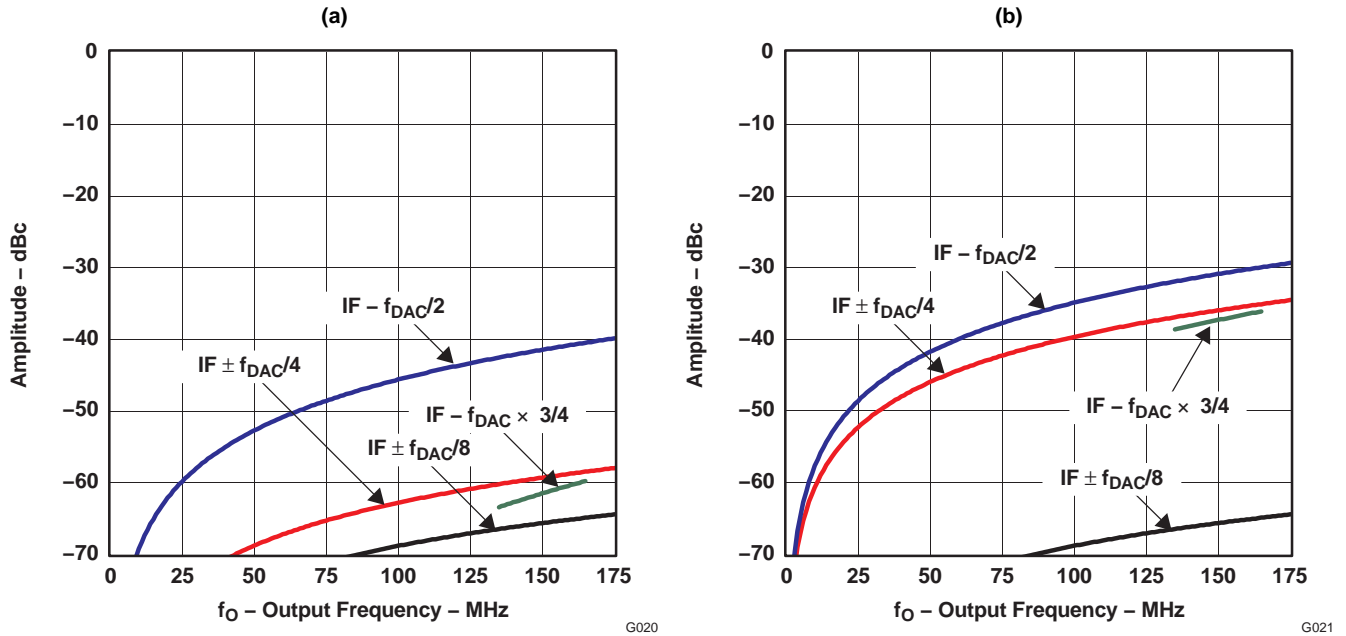

Figure 29. Typical Amplitude of Clock-Related Spurious Signals in (a) External-Clock Mode and (b) PLL Mode

The amplitudes in Figure 29 are typical values and will vary by a few dB across different parts, supply voltages, and temperatures. Figure 28 and Figure 29 can be used to estimate the non-harmonic clock-related harmonic signals. Take the example for using the DAC5686 in external-clock mode, $f_{DAC} = 500$ MHz, 4x interpolation, and $IF = 85$ MHz with a real output. Figure 28(b) and Figure 29(a) predict the spurious signals shown in Table 4.

Table 4. Predicted Frequency and Amplitude for $f_{DAC} = 500$ MHz, 4x Interpolation, $IF = 85$ MHz in External-Clock Mode

Spurious Signal	Frequency (MHz)	Amplitude (dBc)
$IF - f_{DAC}/2$	165	-47
$IF + f_{DAC}/4$	210	-64
$IF - f_{DAC}/4$	40	-64
$IF - f_{DAC} \times 3/4$	> 250	N/A

Figure 30 shows the DAC5686 output spectrum for the preceding example. The amplitudes of the clock-related spurs agree quite well with the predicted amplitudes in Table 4.

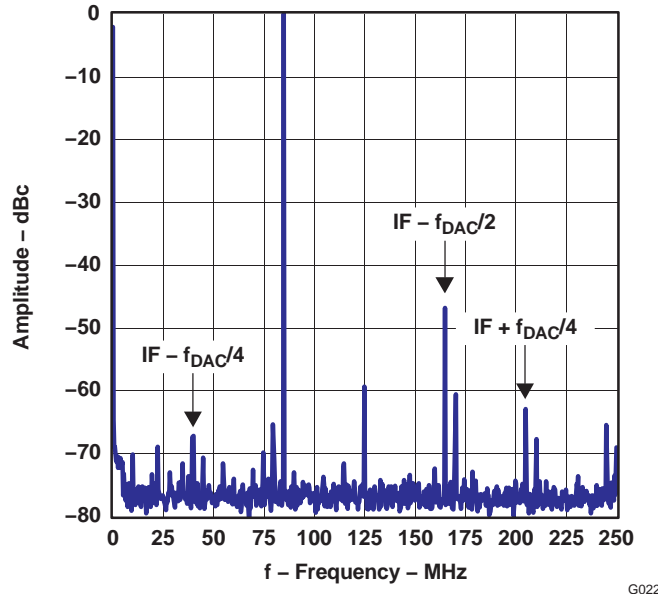

Figure 30. DAC5686 Output Spectrum With $f_{DAC} = 500$ MSPS, 4x Interpolation, IF = 85 MHz, and External-Clock Mode

Dual-Bus Mode

In dual-bus mode, two separate parallel data streams (I and Q) are input to the DAC5686 on data bus **DA** and data bus **DB**. Dual-bus mode is selected by setting **INTERL** to 0 in the **config_msb** register. Figure 31 shows the DAC5686 data path in dual-bus mode. The dual-bus mode timing diagram is shown in Figure 32 for the PLL clock mode and in Figure 33 for the external clock mode.

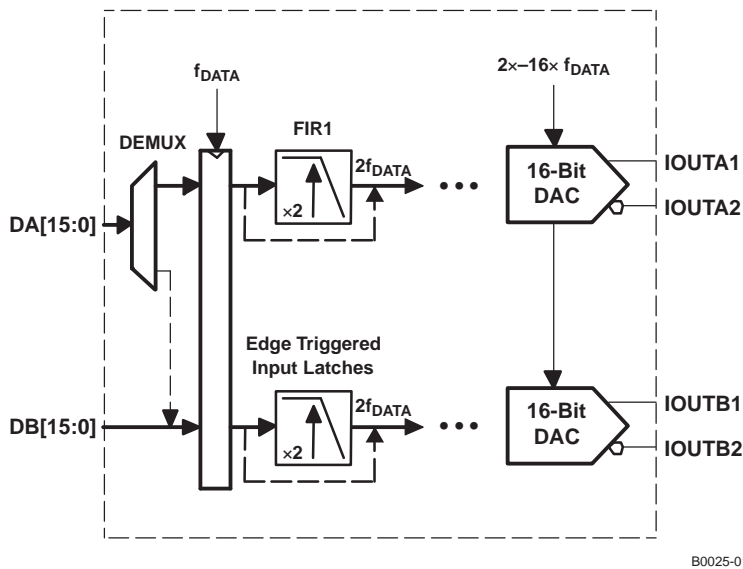
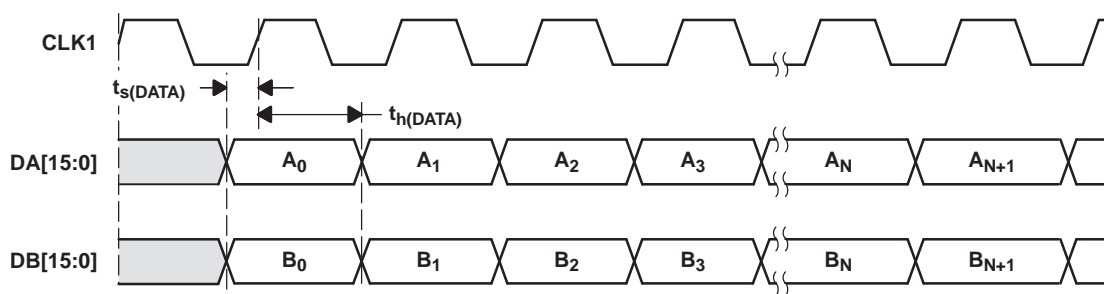
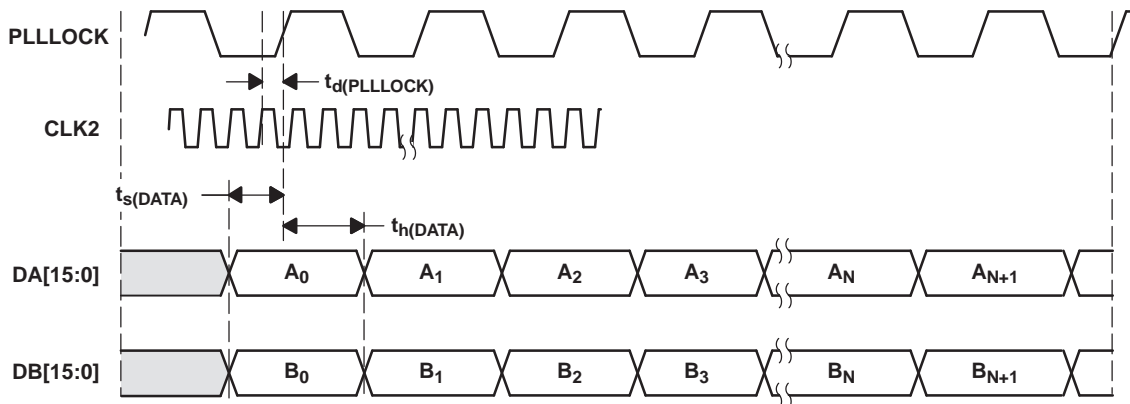

Figure 31. Dual-Bus Mode Data Path



T0039-01

Figure 32. Dual-Bus Mode Timing Diagram (PLL Mode)



T0040-01

Figure 33. Dual-Bus Mode Timing Diagram (External Clock Mode)

Interleave Bus Mode

In interleave bus mode, one parallel data stream with interleaved data (I and Q) is input to the DAC5686 on data bus **DA**. Interleave bus mode is selected by setting **INTERL** to 1 in the **config_msb** register. Figure 34 shows the DAC5686 data path in interleave bus mode. The interleave bus mode timing diagram is shown in Figure 35.

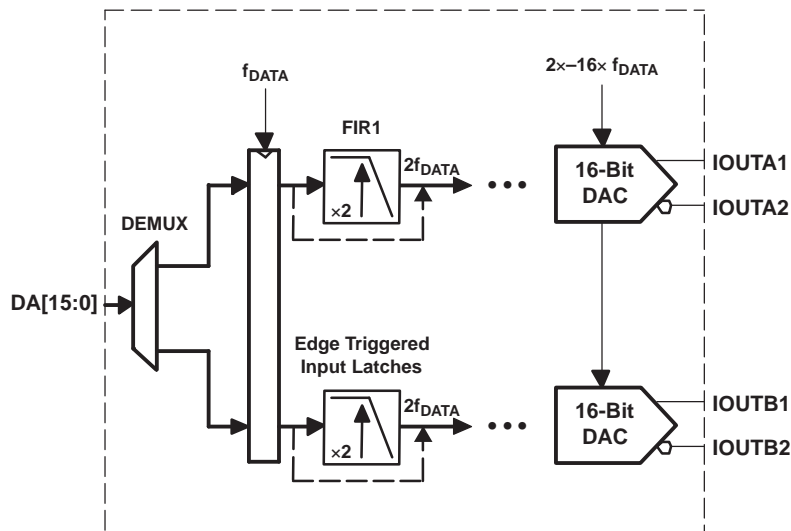

B0025-02

Figure 34. Interleave Bus Mode Data Path

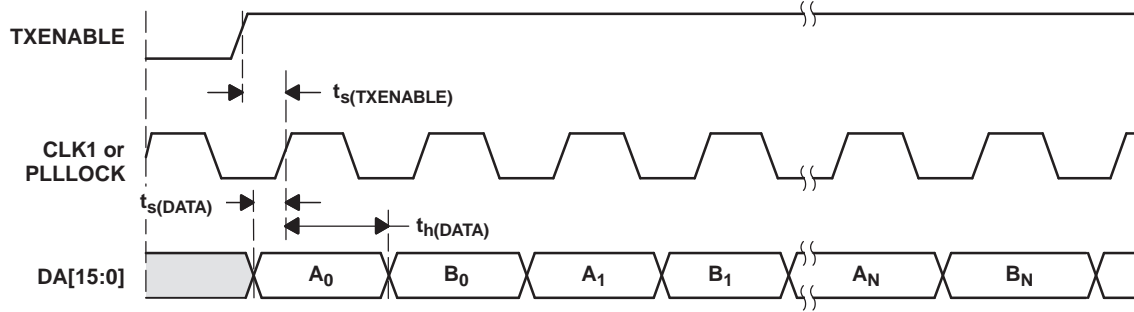

T0041-01

Figure 35. Interleave Bus Mode Timing Diagram Using TxENABLE

Interleaved user data on data bus **DA** is alternately multiplexed to internal data channels A and B. Data channels A and B can be synchronized using either the **QFLAG** pin or the **TxENABLE** pin. When **qflag** in register **config_usb** is 0, transitions on **TxENABLE** identify the interleaved data sequence. The first data after the rising edge of **TxENABLE** is latched with the rising edge of **CLK** as channel-A data. Data is then alternately distributed to B and A channels with successive rising edges of **CLK**. When **qflag** is 1, the **QFLAG** pin is used as an input by the user to identify the interleaved data sequence. **QFLAG** high identifies data as channel B (see Figure 36).

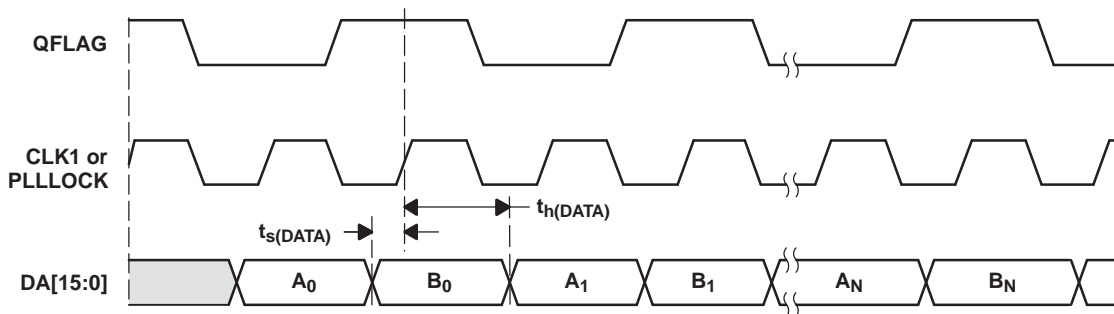

T0001-01

Figure 36. Interleave Bus Mode Timing Diagram Using QFLAG

When using interleaved input mode with the PLL enabled, the input clock CLK1 is at 2x the frequency of the input to FIR1. The divider that generates the clock for the FIR1 input cannot be synchronized between multiple DAC5686s, which can result in a one-CLK1-period output time difference between devices that have synchronized input data. Dual-clock mode is recommended in applications where multiple DAC5686s must be synchronized in interleaved input mode.

The dual-clock mode is selected by setting **dualclk** high in the **config_usb** register. In this mode, the DAC5686 uses both clock inputs; **CLK1/CLK1C** is the input data clock, and **CLK2/CLK2C** is the external clock. The edges of the two input clocks must be phase-aligned within 500 ps to function properly.

Clock Synchronization Using the PHSTR Pin in External Clock Mode

In external clock mode, the DAC5686 is clocked at the DAC output sample frequency (CLK2 and CLK2C). For an interpolation rate N, there are N possible phases for the DAC input clock on the PLLLOCK pin (see Figure 37 for N = 4).

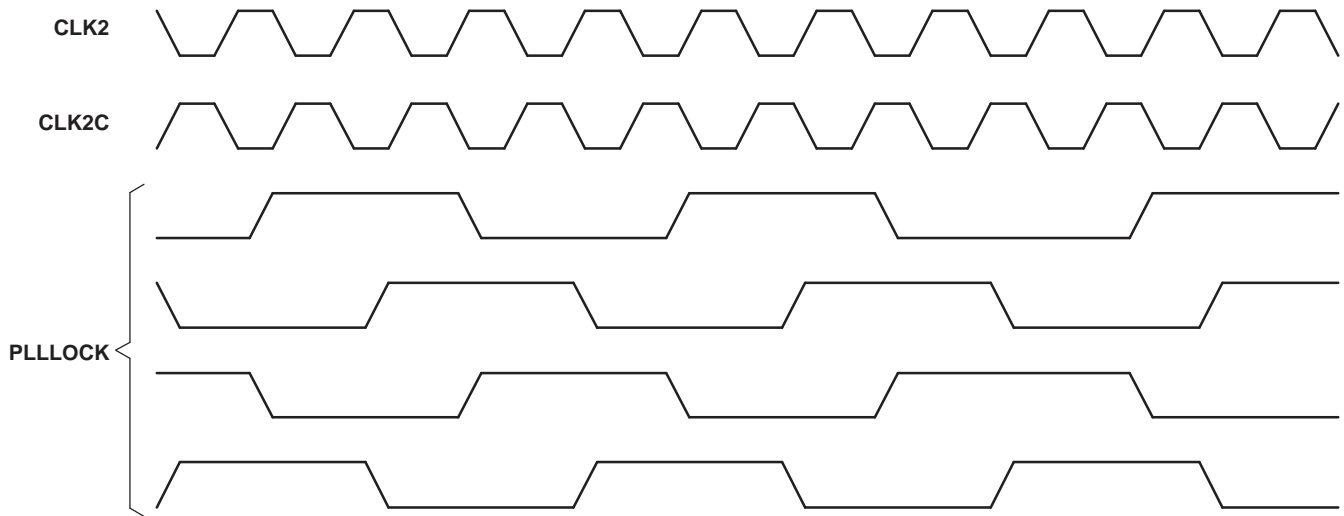

T0003-01

Figure 37. Four Possible PLLLOCK Phases for N = 4 in External Clock Mode

To synchronize PLLLOCK input clocks across multiple DAC5686 chips, a synchronization signal on the PHSTR pin is used. During configuration of the DAC5686 chips, address `sync_phstr` in `config_msb` is set high to enable the PHSTR input pin as a synchronization input to the clock dividers generating the input clock. A simultaneous low-to-high transition on the PHSTR pin for each DAC5686 then forces the input clock on PLLLOCK to start in phase on each DAC. See Figure 38.

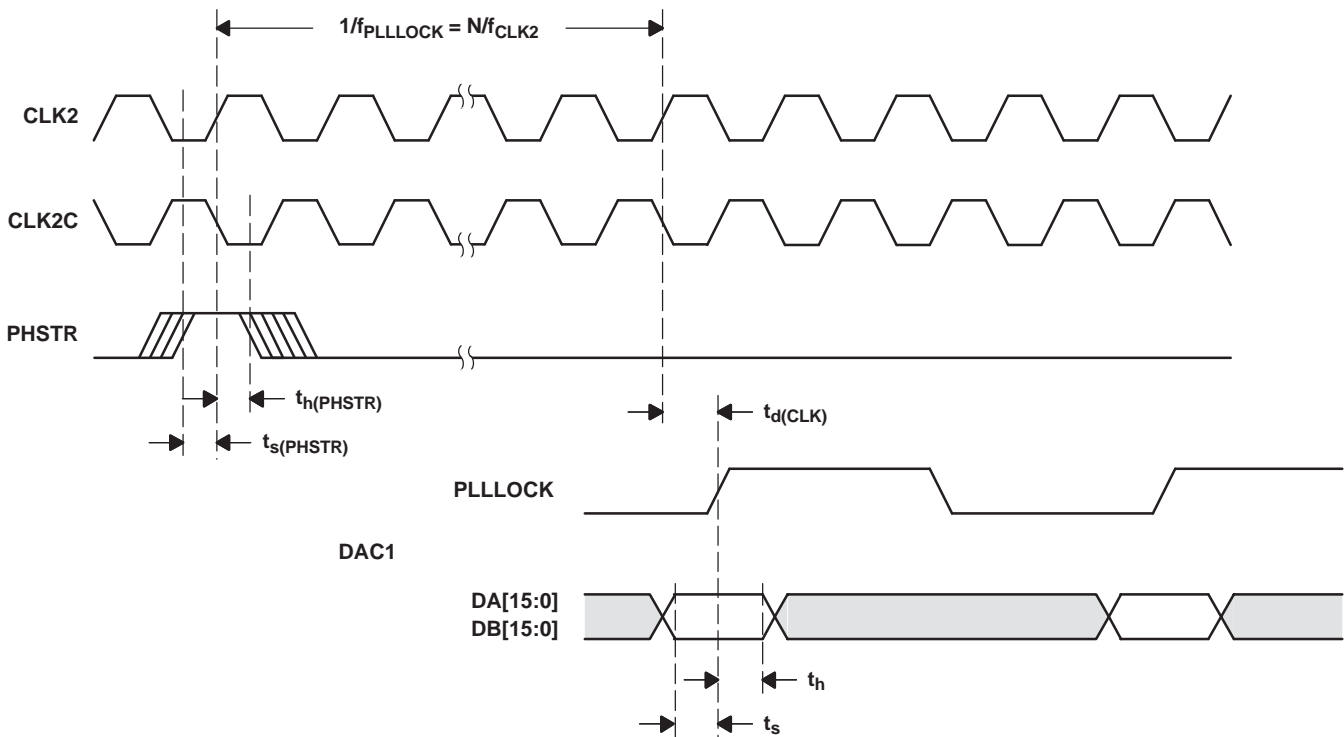

T0004-01

Figure 38. Using PHSTR to Synchronize PLLLOCK Input Clock for Multiple DACs in External Clock Mode

The PHSTR transition has a setup and hold time relative to the DAC output sample clock (t_{s_PHSTR} and t_{h_PHSTR}) equal to 50% of the DAC output sample clock period up to a maximum of 1 ns. At 500 MHz, the setup and hold times are therefore 0.5 ns. The PHSTR signal can remain high after synchronization, or can return low. A new low-to-high transition resynchronizes the input clock. Note that the PHSTR transition also resets the NCO accumulator.

Digital Filters

Figure 39 through Figure 42 show magnitude spectrum responses for 2x, 4x, 8x, and 16x FIR interpolation filtering. The transition band is from 0.4 to 0.6 f_{DATA} with < 0.002-dB pass-band ripple and > 80-dB stop-band attenuation for all four configurations. The filters are linear phase. The **sel** field in register **config_lsb** selects the interpolation filtering rate as 2x, 4x, 8x, or 16x; interpolation filtering can be completely bypassed by setting **fullbypass** in register **config_lsb**.

Figure 43 shows the spectral correction of the DAC sinc/x rolloff achieved with use of inverse sinc filtering. Pass-band ripple from 0 to 0.4 f_{DATA} is < 0.03 dB. Inverse sinc filtering is enabled by **sinc** in register **config_msb**.

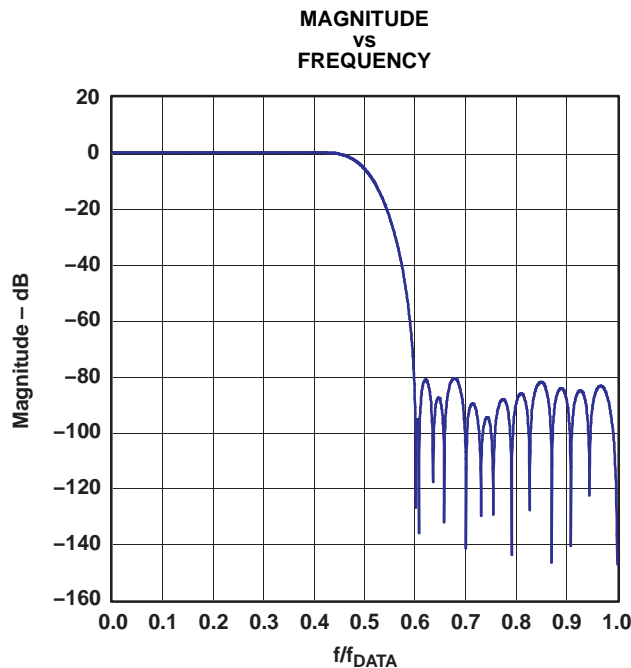

Figure 39. Magnitude Spectrum for 2x Interpolation (dB)

G023

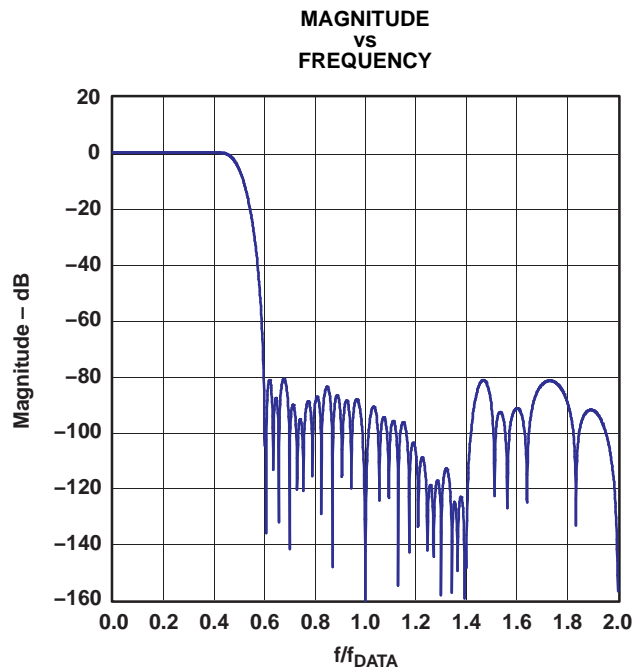

Figure 40. Magnitude Spectrum for 4x Interpolation (dB)

G024

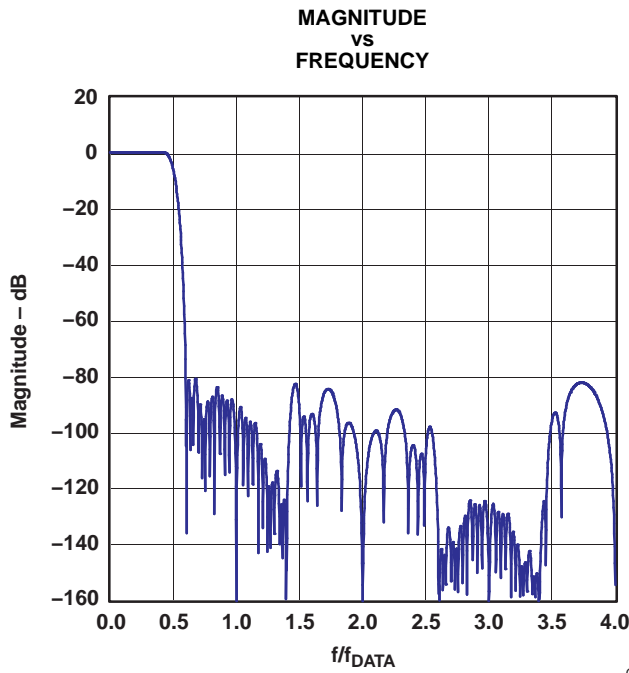

Figure 41. Magnitude Spectrum for 8x Interpolation (dB)

G025

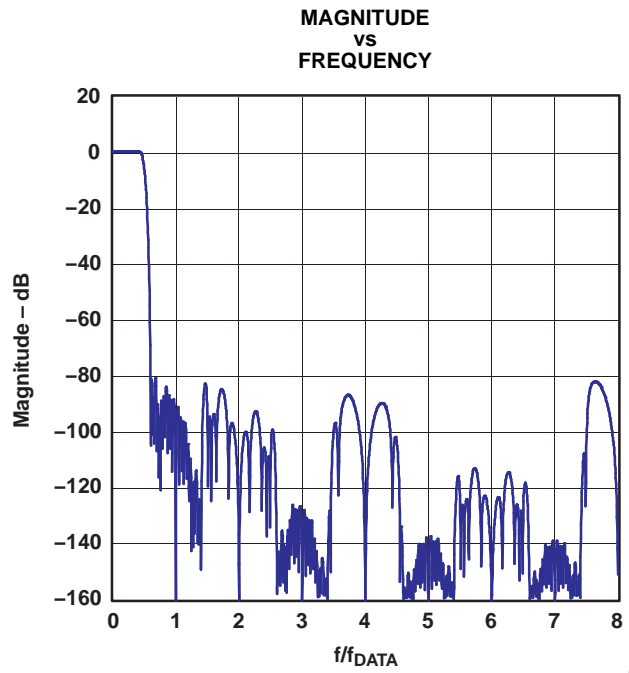

Figure 42. Magnitude Spectrum for 16x Interpolation (dB)

G026

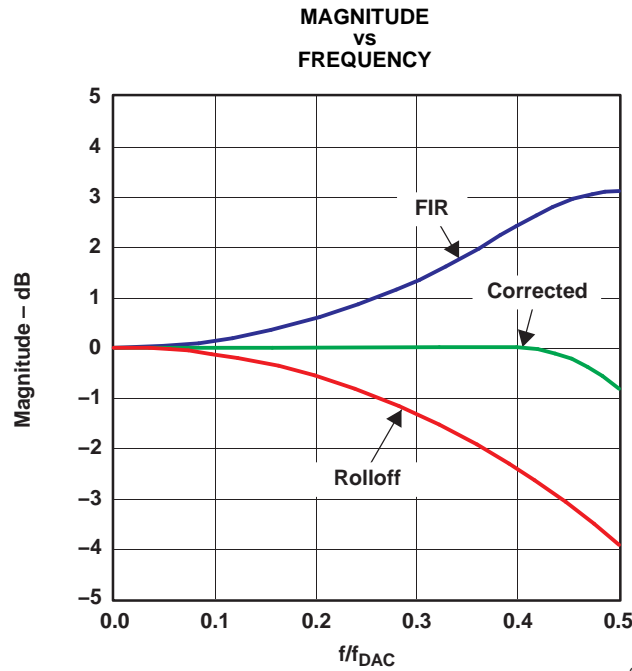

Figure 43. Magnitude Spectrum for Inverse sinc Filtering

G027

The filter taps for interpolation filters FIR1–FIR4 and inverse sinc filter FIR5 are listed in [Table 5](#).

Table 5. Filter Taps for FIR1–FIR5

FIR1	FIR2	FIR3	FIR4	FIR5 (INVSINC)
8	9	31	-33	1
0	0	0	0	-3
-24	-58	-219	289	9
0	0	0	512	-34
58	214	1212	289	400
0	0	2048	0	-34
-120	-638	1212	-33	9
0	0	0		-3
221	2521	-219		1
0	4096	0		
-380	2521	31		
0	0			
619	-638			
0	0			
-971	214			
0	0			
1490	-58			
0	0			
-2288	9			
0				
3649				
0				
-6628				
0				
20750				
32768				
20750				
0				
-6628				
0				
3649				
0				
-2288				
0				
1490				
0				
-971				
0				
619				
0				
-380				
0				
221				
0				
-120				

Table 5. Filter Taps for FIR1–FIR5 (continued)

FIR1	FIR2	FIR3	FIR4	FIR5 (INVSINC)
0				
58				
0				
-24				
0				
8				

NCO

The DAC5686 uses a numerically controlled oscillator (NCO) with a 32-bit frequency register and a 16-bit phase register. The NCO is used in quadrature-modulation and single-sideband modes to provide sin and cos for mixing. The NCO tuning frequency is programmed in registers 0x1 through 0x4. Phase offset is programmed in registers 0x5 and 0x6. A block diagram of the NCO is shown in Figure 44.

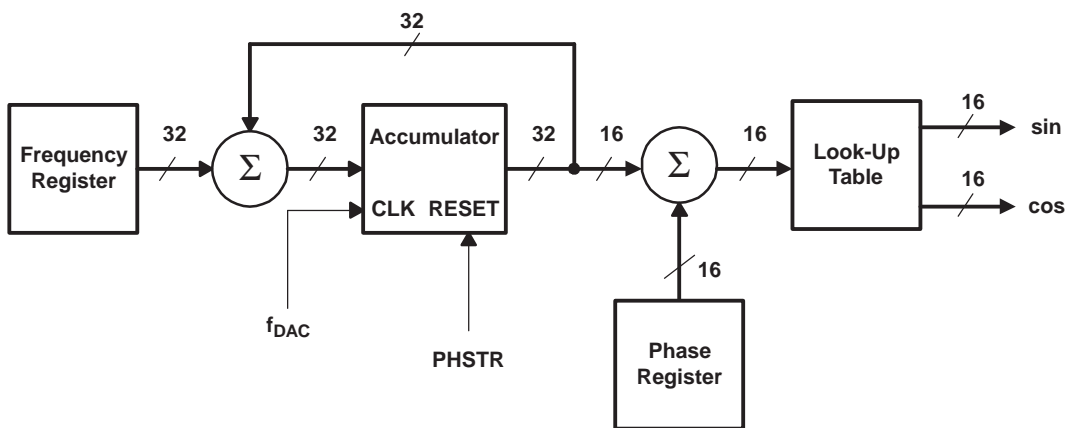

B0026-01

Figure 44. Block Diagram of the NCO

The NCO accumulator is reset to zero when the PHSTR pin is high and remains at zero until PHSTR is set low. Frequency word **freq** in the frequency register is added to the accumulator every clock cycle. The output frequency of the NCO is:

$$f_{NCO} = \frac{freq \times f_{DAC}}{2^{32}}$$

While the maximum clock frequency of the DACs is 500 MSPS, the maximum clock frequency the NCO can operate at is 320 MHz; mixing at DAC rates higher than 320 MSPS requires using the f_{DAC}/4 mixing option.

Register Bit Allocation Map

NAME	R/W	ADDRESS	BIT 7	BIT 6	BIT 5	BIT 4	BIT 3	BIT 2	BIT 1	BIT 0
chip_ver	R/W	0x00	atest[4:0]				version[2:0] <i>read only</i>			
freq_lsb	R/W	0x01	freq_int[7:0]							
freq_lmidsb	R/W	0x02	freq_int[15:8]							
freq_umidsb	R/W	0x03	freq_int[23:16]							
freq_msb	R/W	0x04	freq_int[31:24]							
phase_lsb	R/W	0x05	phase_int[7:0]							
phase_msb	R/W	0x06	phase_int[15:8]							
config_lsb	R/W	0x07	mode[1:0]		div[1:0]		sel[1:0]		counter	full_bypass
config_msb	R/W	0x08	ssb	interl	sinc	dith	sync_phstr	nco	sif4	twos
config_usb	R/W	0x09	dual_clk	DDS_gain[1:0]		rspect	qflag	PLL_rng[1:0]		rev_bbus
daca_offset_lsb	R/W	0x0A	daca_offset[7:0]							
daca_gain_lsb	R/W	0x0B	daca_gain[7:0]							
daca_offset_gain_msb	R/W	0x0C	daca_offset[10:8]			sleepa	daca_gain[11:8]			
dacb_offset_lsb	R/W	0x0D	dacb_offset[7:0]							
dacb_gain_lsb	R/W	0x0E	dacb_gain[7:0]							
dacb_offset_gain_msb	R/W	0x0F	dacb_offset[10:8]			sleepb	dacb_gain[11:8]			

REGISTER DESCRIPTIONS

Register Name: chip_ver

MSB					LSB		
atest[4:0]					chip_ver[2:0] <i>read only</i>		
0	0	0	0	0	1	0	1

chip_ver[3:0]: chip_ver [3:0] stores the device version, initially 0x5. The user can find out which version of the DAC5686 is in the system by reading this byte.

a_test[4:0]: must be 0 for proper operation.

Register Name: freq_lsb

MSB							LSB
freq_int[7:0]							
0	0	0	0	0	0	0	0

freq_int[7:0]: The lower 8 bits of the frequency register in the DDS block

Register Name: freq_lmidsb

MSB							LSB
freq_int[15:8]							
0	0	0	0	0	0	0	0

freq_int[15:8]: The lower mid 8 bits of the frequency register in the DDS block

Register Name: freq_umidsb

MSB							LSB
freq_int[23:16]							
0	0	0	0	0	0	0	0

freq_int[23:16]: The upper mid 8 bits of the frequency register in the DDS block

Register Name: freq_msb

MSB							LSB
freq_int[31:24]							
0	0	1	0	0	0	0	0

freq_int[31:24]: The most significant 8 bits of the frequency register in the DDS block

Register Name: phase_lsb

MSB							LSB
phase_int[7:0]							
0	0	0	0	0	0	0	0

phase_int[7:0]: The lower 8 bits of the phase register in the DDS block

Register Name: phase_msb

MSB							LSB
phase_int[15:8]							
0	0	0	0	0	0	0	0

phase_int[15:8]: The most significant 8 bits of the phase register in the DDS block

Register Name: config_lsb

MSB						LSB	
mode[1:0]		div[1:0]		sel[1:0]		counter	Full_bypass
0	0	0	0	0	0	0	1

mode[1:0]: Controls the mode of the DAC5686; summarized in [Table 6](#).

Table 6. DAC5686 Modes

mode[1:0]	DAC5686 MODE
00	Dual-DAC
01	Single-sideband
10	Quadrature
11	Dual-DAC

div[1:0]: Controls the PLL divider value; summarized in [Table 7](#).

Table 7. PLL Divide Ratios

div[1:0]	PLL DIVIDE RATIO
00	1x divider
01	2x divider
10	4x divider
11	8x divider

sel[1:0]: Controls the selection of interpolating filters used; summarized in [Table 8](#).

Table 8. DAC5686 Filter Configuration

sel[1:0]	INTERP. FIR SETTING
00	x2
01	x4
10	x8
11	x16

counter: When asserted, the DAC5686 goes into counter mode and uses an internal counter as a ramp input to the DAC. The count range is determined by the A-side input data DA[2:0], as summarized in [Table 9](#).

Table 9. DAC5686 Counter Mode Count Range

DA[2:0]	COUNT RANGE
000	All bits D[15:0]
001	Lower 7 bits D[6:0]
010	Mid 4 bits D[10:7]
100	Upper 5 bits D[15:11]

full_bypass: When asserted, the interpolation filters and mixer logic are bypassed, and the data inputs DA[15:0] and DB[15:0] go straight to the DAC inputs.

Register Name: config_msb

MSB							LSB
ssb	interl	sinc	dith	sync_phstr	nco	sif4	twos
0	0	0	0	0	0	0	0

ssb: In single-sideband mode, assertion inverts the B data; in quadrature modulation mode, assertion routes the A data path to DACB instead of the B data path.

interl: When asserted, data input to the DAC5686 on channel DA[15:0] is interpreted as a single interleaved stream (I/Q); channel DB[15:0] is unused.

sinc: Assertion enables the INVSINC filter.

dith: Assertion enables dithering in the PLL.

sync_phstr: Assertion enables the PHSTR input as a sync input to the clock dividers in external single-clock mode.

nco: Assertion enables the NCO.

sif4: When asserted, the sif interface becomes a 4-pin interface instead of a 3-pin interface. The SDIO pin becomes an input only, and the SDO is the output.

twos: When asserted, the chip interprets the input data as 2s complement form instead of binary offset.

Register Name: config_usb

MSB						LSB	
dualclk	DDS_gain[1:0]		rspect	qflag	pll_rng[1:0]		rev_bbuss
0	0	0	0	0	0	0	0

dual_clk: When asserted, the DAC5686 uses both clock inputs; CLK1/CLK1C is the input data clock and CLK2/CLK2C is the DAC output clock. These two clocks must be phase-aligned within 500 ps to function properly. When deasserted, CLK2/CLK2C is the DAC output clock and is divided down to generate the input data clock, which is output on PLLLOCK. Dual clock mode is only available when PLLVDD = 0.

DDS_gain[1:0]: Controls the gain of the DDS so that the overall gain of the DDS is unity. It is important to

ensure that $\max(\cos(\omega t) + \sin(\omega t)) < 1$. At different frequencies, the summation produces different maximum outputs and must be reduced. The simplest is $f_{DAC}/4$ mode where the maximum is 1 and the gain multiply should be 1 to maintain unity. However, due to the fact that the digital logic does a divide-by-two in this summation, the gain necessary to achieve unity must be double ($DDS_gain[1:0] = 01$). [Table 10](#) shows the digital gain necessary and the actual signal gain needed to make the above equation have a maximum value of 1.

Table 10. Digital Gain for DDS

DDS_gain [1:0]	DIGITAL GAIN	SIGNAL GAIN FOR UNITY
00	1.40625	0.703125
01	2	1
10	1.59375	0.7936
11	1.40625	0.703125

rspect: When asserted, the sin term is negated before being used in mixing. This gives the reverse spectrum in single-sideband mode.

qflag: When asserted, the QFLAG pin is used by the user as an input indicator during interleaved data input mode to identify the Q sample. When deasserted, the TxENABLE pin transition is used to start an internal toggling signal, which is used to interpret the interleaved data sequence; the first sample clocked into the DAC5686 after TxENABLE goes high is routed through the A data path.

PLL_rng[1:0]: Increases the PLL VCO Vtol current, summarized in [Table 11](#). See [Figure 17](#) for the effect on VCO gain and range.

Table 11. PLL VCO Vtol Current Increase

PLL_rng[1:0]	Vtol CURRENT INCREASE
00	nominal
01	15%
10	30%
11	45%

rev_bbus[1:0]: When asserted, pin 92 changes from DB15 to DB0, pin 91 changes from DB14 to DB1, etc., reversing the order of the DB[15:0] pins.

Register Name: dca_offset_lsb (2s complement)

MSB							LSB
dca_offset[7:0]							
0	0	0	0	0	0	0	0

dca_offset[7:0]: The lower 8 bits of the DACA offset

Register Name: dca_gain_lsb (2s complement)

MSB							LSB
dca_gain[7:0]							
0	0	0	0	0	0	0	0

dca_gain[7:0]: The lower 8 bits of the DACA gain control register. These lower 8 bits are for fine gain control. This word is a 2s complement value that adjusts the full-scale output current over an approximate 4% to –4% range.

Register Name: dca_offset_gain_msb (2s complement)

MSB			sleepa		LSB		
dca_offset[10:8]					dca_gain[11:8]		
0	0	0	0	0	0	0	0

dca_offset[10:8]: The upper 3 bits of the DACA_offset

sleepa: When asserted, DACA is put into the sleep mode.

daca_gain[11:8]: Coarse gain control for DACA; the full-scale output current is:

$$I_{fullscale} = \left[\frac{16(V_{extio})}{R_{biasj}} \times \frac{(GAINCODE + 1)}{16} \div \left(1 - \frac{FINEGAIN}{3072} \right) \right]$$

where GAINCODE is the decimal equivalent of daca_gain [11:8] {0...15} and the FINEGAIN is daca_gain [7:0] as 2s complement {-127...128}.

Register Name: dacb_offset_lsb (2s complement)

MSB				LSB			
dacb_offset[7:0]							
0	0	0	0	0	0	0	0

dacb_offset[7:0]: The lower 8 bits of the DACB offset

Register Name: dacb_gain_lsb (2s complement)

MSB				LSB			
dacb_gain[7:0]							
0	0	0	0	0	0	0	0

dacb_gain[7:0]: The lower 8 bits of the DACB gain control register. These lower 8 bits are for fine gain control. This word is a 2s complement value that adjusts the full-scale output current over an approximate 4% to -4% range.

Register Name: dacb_offset_gain_msb (2s complement)

MSB			LSB				
dacb_offset[10:8]			sleepb	dacb_gain[11:8]			
0	0	0	0	0	0	0	0

dacb_offset[10:8]: The upper 3 bits of the DACA_offset

sleepb: When asserted, DACB is put into the sleep mode.

dacb_gain[11:8]: Coarse gain control for DACB; the full-scale output current is:

$$I_{fullscale} = \left[\frac{16(V_{extio})}{R_{biasj}} \times \frac{(GAINCODE + 1)}{16} \div \left(1 - \frac{FINEGAIN}{3072} \right) \right]$$

where GAINCODE is the decimal equivalent of dacb_gain [11:8] {0...15} and the FINEGAIN is dacb_gain [1:0] as 2s complement {-127...128}.

DIGITAL INPUTS

Figure 45 shows a schematic of the equivalent CMOS digital inputs of the DAC5686. DA[15:0], DB[15:0], SLEEP, PHSTR, TxENABLE, QFLAG, SDIO, SCLK, and SDENB have pull-down resistors and RESETB has a pullup resistor internal to the DAC5686. The pullup and pull-down circuitry is approximately equivalent to 100 kΩ. See the specification table for logic thresholds.

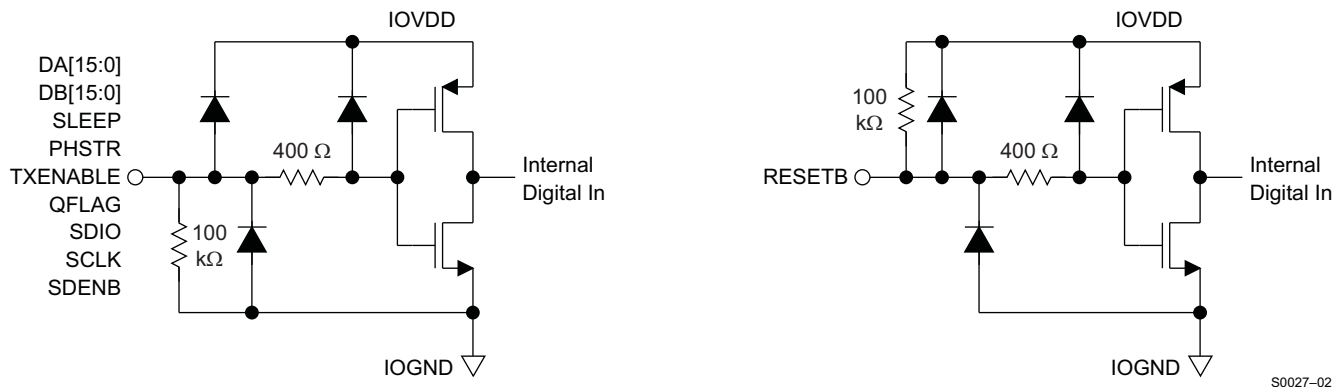

Figure 45. CMOS/TTL Digital Equivalent Input

CLOCK INPUT AND TIMING

Figure 46 shows an equivalent circuit for the clock input.

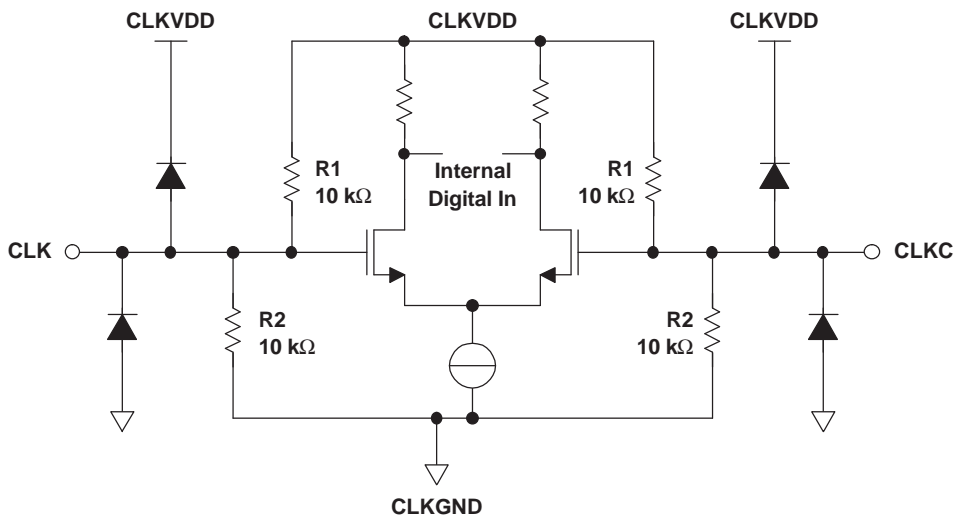
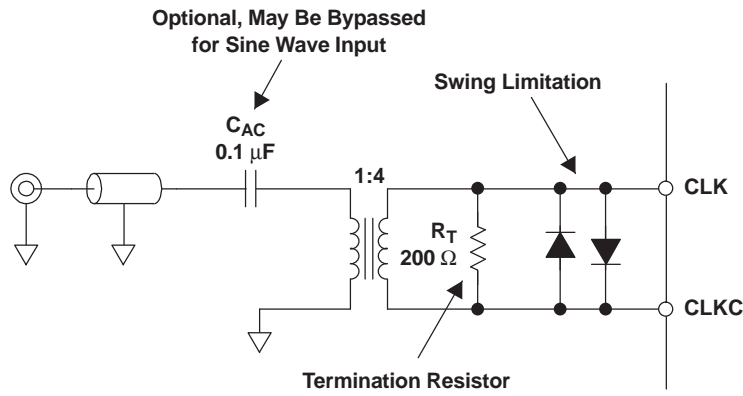

Figure 46. Clock Input Equivalent Circuit

Figure 47, Figure 48, and Figure 49 show various input configurations for driving the differential clock input (CLK/CLKC).



S0029-01

Figure 47. Preferred Clock Input Configuration

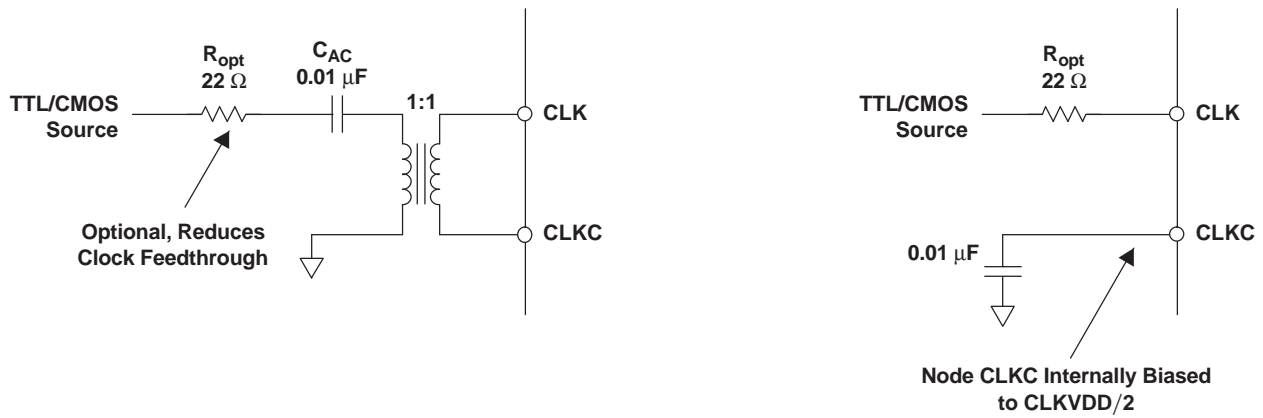

S0030-01

Figure 48. Driving the DAC5686 With a Single-Ended TTL/CMOS Clock Source

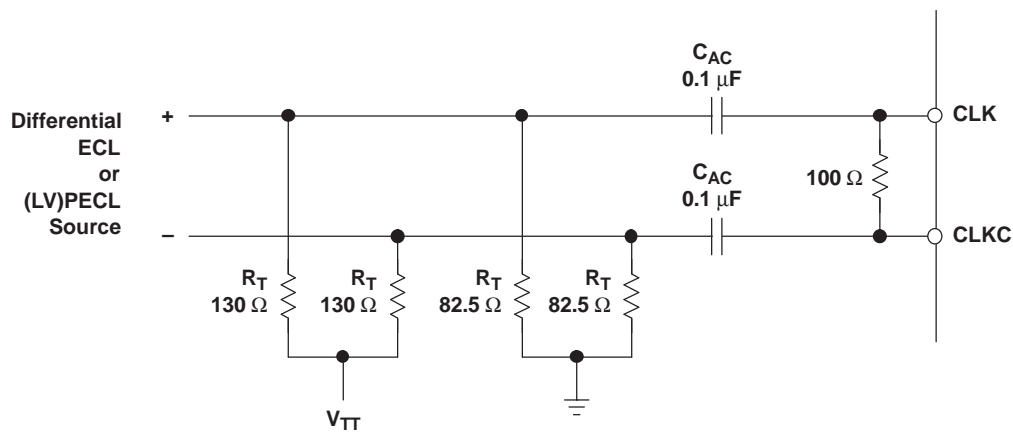

S0031-01

Figure 49. Driving the DAC5686 With a Differential ECL/PECL Clock Source

DAC Transfer Function

The CMOS DAC's consist of a segmented array of NMOS current sinks, capable of sinking a full-scale output current up to 20 mA. Differential current switches direct the current of each current source through either one of the complementary output nodes IOUT1 or IOUT2. Complementary output currents enable differential operation, thus canceling out common mode noise sources (digital feed-through, on-chip and PCB noise), dc offsets, even order distortion components, and increasing signal output power by a factor of two.

The full-scale output current is set using external resistor R_{BIAS} in combination with an on-chip bandgap voltage reference source (1.2 V) and control amplifier. Current I_{BIAS} through resistor R_{BIAS} is mirrored internally to provide a full-scale output current equal to 16 times I_{BIAS} . The full-scale current $I_{OUT_{FS}}$ can be adjusted from 20 mA down to 2 mA.

The relation between IOUT1 and IOUT2 can be expressed as:

$$I_{OUT1} = -I_{OUT_{FS}} - I_{OUT2}$$

We denote current flowing into a node as – current and current flowing out of a node as + current. Because the output stage is a current sink, the current can only flow from AVDD into the IOUT1 and IOUT2 pins. If $I_{OUT2} = -5$ mA and $I_{OUT_{FS}} = 20$ mA then:

$$I_{OUT1} = -20 - (-5) = -15 \text{ mA}$$

The output current flow in each pin driving a resistive load can be expressed as:

$$I_{OUT1} = I_{OUT_{FS}} \times (65535 - \text{CODE}) / 65536$$

$$I_{OUT2} = I_{OUT_{FS}} \times \text{CODE} / 65536$$

where CODE is the decimal representation of the DAC data input word.

For the case where IOUT1 and IOUT2 drive resistor loads R_L directly, this translates into single ended voltages at IOUT1 and IOUT2:

$$V_{OUT1} = AVDD - |I_{OUT1}| \times R_L$$

$$V_{OUT2} = AVDD - |I_{OUT2}| \times R_L$$

Assuming that the data is full scale (65535 in offset binary notation) and the R_L is 25 Ω , the differential voltage between pins IOUT1 and IOUT2 can be expressed as:

$$V_{OUT1} = AVDD - | -20 \text{ mA} | \times 25 \Omega = 2.8 \text{ V}$$

$$V_{OUT2} = AVDD - | -0 \text{ mA} | \times 25 \Omega = 3.3 \text{ V}$$

$$V_{DIFF} = V_{OUT1} - V_{OUT2} = 0.5 \text{ V}$$

Note that care should be taken not to exceed the compliance voltages at node IOUT1 and IOUT2, which would lead to increased signal distortion.

Reference Operation

The DAC5686 comprises a band-gap reference and control amplifier for biasing the full-scale output current. The full-scale output current is set by applying an external resistor R_{BIAS} . The bias current I_{BIAS} through resistor R_{BIAS} is defined by the on-chip band-gap reference voltage and control amplifier. The full-scale output current equals 16 times this bias current. The full-scale output current $I_{OUT_{FS}}$ can thus be expressed as (coarse gain = 15, fine gain = 0):

$$I_{OUT_{FS}} = \frac{16 \times V_{EXTIO}}{R_{BIAS}}$$

where V_{EXTIO} is the voltage at terminal EXTIO. The band-gap reference voltage delivers an accurate voltage of 1.2 V. This reference is active when terminal EXTLO is connected to AGND. An external decoupling capacitor C_{EXT} of 0.1 μF should be connected externally to terminal EXTIO for compensation. The band-gap reference additionally can be used for external reference operation. In that case, an external buffer with a high-impedance input should be used in order to limit the band-gap load current to a maximum of 100 nA. The internal reference can be disabled and overridden by an external reference by connecting EXTLO to AVDD. Capacitor C_{EXT} may hence be omitted. Terminal EXTIO serves as either input or output node.

The full-scale output current can be adjusted from 20 mA down to 2 mA by varying resistor R_{BIAS} or changing the externally applied reference voltage. The internal control amplifier has a wide input range supporting the full-scale output current range of 20 dB.

Analog Current Outputs

Figure 50 shows a simplified schematic of the current source array with corresponding switches. Differential switches direct the current of each individual NMOS current source to either the positive output node IOU1 or its complementary negative output node IOU2. The output impedance is determined by the stack of the current sources and differential switches and is typically $>300\text{ k}\Omega$ in parallel with an output capacitance of 5 pF .

The external output resistors are terminated to AVDD. The maximum output compliance at nodes IOU1 and IOU2 is limited to $AVDD + 0.5\text{ V}$, determined by the CMOS process. Beyond this value, transistor breakdown can occur, resulting in reduced reliability of the DAC5686 device. The minimum output compliance voltage at nodes IOU1 and IOU2 equals $AVDD - 0.5\text{ V}$. Exceeding the minimum output compliance voltage adversely affects distortion performance and integral nonlinearity. The optimum distortion performance for a single-ended or differential output is achieved when the maximum full-scale signal at IOU1 and IOU2 does not exceed 0.5 V .

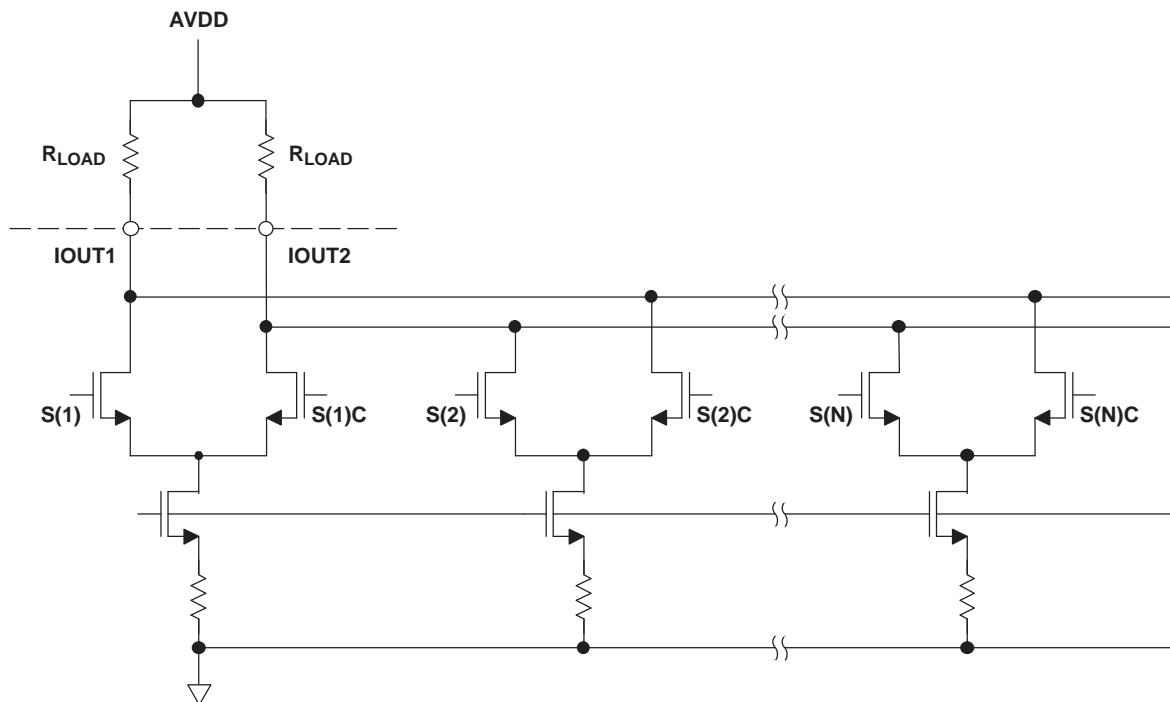

S0032-01

Figure 50. Equivalent Analog Current Output

The DAC5686 can be easily configured to drive a doubly terminated $50\text{-}\Omega$ cable using a properly selected RF transformer. Figure 51 and Figure 52 show the $50\text{-}\Omega$ doubly terminated transformer configuration with 1:1 and 4:1 impedance ratios, respectively. Note that the center tap of the primary input of the transformer must be connected to AVDD to enable a dc current flow. Applying a 20-mA full-scale output current would lead to a 0.5-Vpp output for a 1:1 transformer and a 1-Vpp output for a 4:1 transformer.

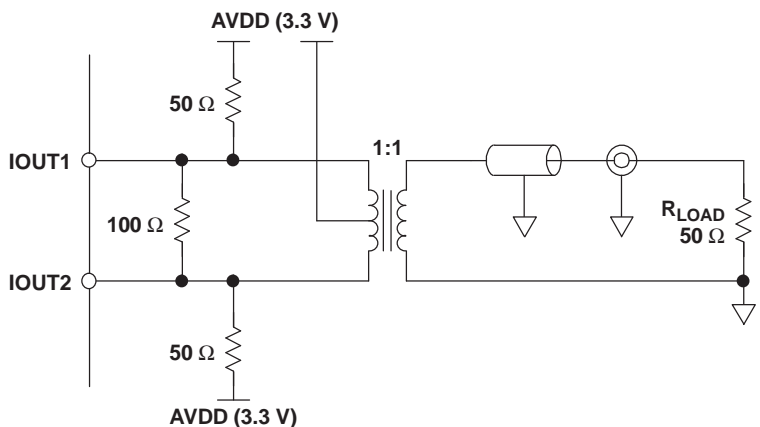

S0033-01

Figure 51. Driving a Doubly Terminated 50-Ω Cable Using a 1:1 Impedance-Ratio Transformer

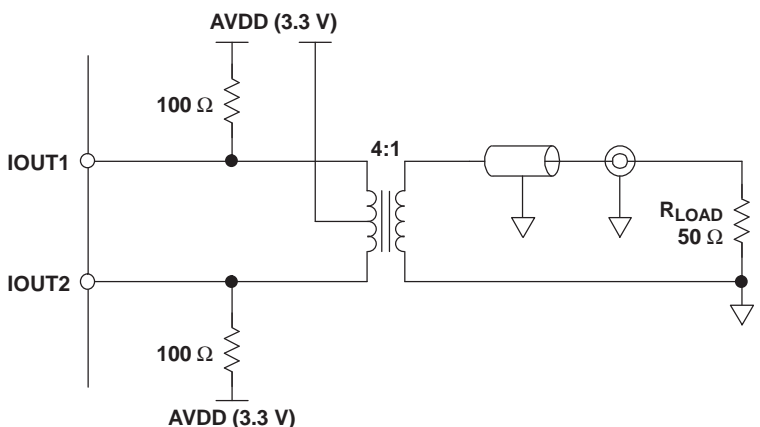

S0033-02

Figure 52. Driving a Doubly Terminated 50-Ω Cable Using a 4:1 Impedance-Ratio Transformer

SLEEP MODE

The DAC5686 features a power-down mode that turns off the output current and reduces the supply current to less than 5 mA over the supply range of 3 V to 3.6 V and temperature range of -40°C to 85°C . The power-down mode is activated by applying a logic level 1 to the SLEEP pin (e.g., by connecting pin SLEEP to IOVDD). An internal pulldown circuit at node SLEEP ensures that the DAC5686 is enabled if the input is left disconnected. Power-up and power-down activation times depend on the value of the external capacitor at node SLEEP. For a nominal capacitor value of 0.1 mF, it takes less than 5 ms to power down and approximately 3 ms to power up.

POWER-UP SEQUENCE

In all conditions, bring up DVDD first. If PLLVDD is powered (PLL on), CLKVDD should be powered before or simultaneously with PLLVDD. AVDD, CLKVDD and IOVDD can be powered simultaneously or in any order. Within AVDD, the multiple AVDD pins should be powered simultaneously.

DAC5686 EVALUATION BOARD

There is a combination EVM board for the DAC5686 digital-to-analog converter for evaluation. This board allows the user the flexibility to operate the DAC5686 in various configurations. Possible output configurations include transformer-coupled, resistor-terminated, inverting/non-inverting and differential amplifier outputs. The digital inputs are designed to be driven directly from various pattern generators with the onboard option to add a resistor network for proper load termination.

APPENDIX A. PLL LOOP FILTER COMPONENTS

DESIGNING THE PLL LOOP FILTER

The DAC5686 contains an external loop filter to set the bandwidth and phase margin of the PLL. For the external second-order filter shown in Figure 53, the components R1, C1, and C2 are set by the user to optimize the PLL for the application. The resistance R3 = 200 Ω and the capacitance C3 = 8 pF are internal to the DAC5686. Note that the positions of R1 and C1 can be reversed, relative to each other.

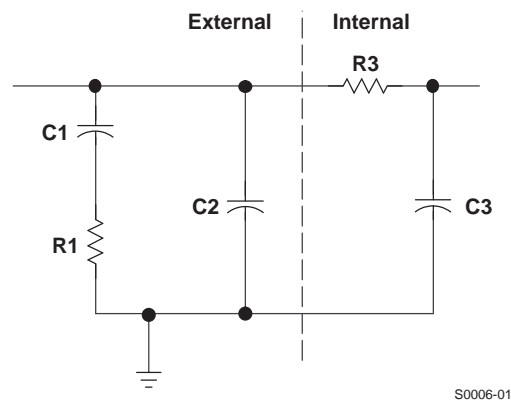

Figure 53. DAC5686 Loop Filter

The typical VCO gain (G_{vco}) (the slope of VCO frequency vs voltage) as a function of VCO frequency for the DAC5686 is shown in Figure 17. The VCO frequency range can be extended to higher frequencies by setting the `pll_rng[1:0]` registers to increase the VCO V_{tol} current (see Table 11). However, only the range for `PLL_rng = 00` (nominal) is specified.

For the lowest possible phase noise, the VCO frequency should be chosen so G_{vco} is minimized, where

$$f_{vco} = f_{data} \times \text{Interpolation} \times \text{PLL Divider}$$

For example, if $f_{data} = 125$ MSPS and 2x interpolation is used, the PLL divider should be set to 2 to lock the VCO at 500 MHz for a typical G_{vco} of 200 MHz/V.

The external loop filter components C1, C2, and R1 are determined by choosing G_{vco} , $N = f_{vco}/f_{data}$, the loop phase margin ϕ_d , and the loop bandwidth ω_d . Except for applications where abrupt clock frequency changes require a fast PLL lock time, it is suggested that ϕ_d be set to at least 80 degrees for stable locking and suppression of the phase-noise side lobes. Phase margins of 60 degrees or less occasionally have been sensitive to board layout and decoupling details.

The optimum loop bandwidth ω_d depends on both the VCO phase noise, which is largely a function of G_{vco} , and the application. For the example above with $G_{vco} = 200$ MHz/V, an $\omega_d = 1$ MHz would be typical, but lower or higher loop bandwidths may provide better phase noise characteristics. For a higher G_{vco} , for example $G_{vco} = 400$ MHz/V, an $\omega_d \sim 7$ MHz would be typical. However, it is suggested that customers experiment with varying the loop bandwidth at least from x to $2x$ to verify the optimum setting.

C1, C2, and R1 are then calculated by the following equations:

$$C1 = \tau1 \left(1 - \frac{\tau2}{\tau3} \right)$$

$$C2 = \frac{\tau1 \times \tau2}{\tau3}$$

$$R1 = \frac{\tau3^2}{\tau1(\tau3 - \tau2)}$$

where

$$\tau1 = \frac{K_d K_{VCO}}{\omega_d^2} (\tan \phi_d + \sec \phi_d)$$

$$\tau2 = \frac{1}{\omega_d (\tan \phi_d + \sec \phi_d)}$$

$$\tau3 = \frac{\tan \phi_d + \sec \phi_d}{\omega_d}$$

and

Charge pump current:	$i_{qp} = 1 \text{ mA}$
VCO gain:	$K_{VCO} = 2\pi \times G_{VCO} \text{ rad/A}$
f_{VCO}/f_{data} :	$N = \{2, 4, 8, 16, 32\}$
Phase detector gain:	$K_d = i_{qp} \times (2\pi N)^{-1} \text{ A/rad}$

An Excel™ [spreadsheet](http://www-s.ti.com/sc/psheets/scac057/scac057.zip) is available on the TI Web site at <http://www-s.ti.com/sc/psheets/scac057/scac057.zip> for automatically calculating the values for C1, C2, and R1.

Completing the preceding example with

PARAMETER	VALUE	UNIT
Gvco	2.00E+02	MHz/V
ω_d	1.00E+00	MHz
N	4	
ϕ_d	80	

the component values are

C1 (F)	C2 (F)	R1 (Ω)
1.44E–08	1.11E–10	1.27E+02

Because the PLL characteristics are not sensitive to these components, the closest 20%-tolerance capacitor and 1%-tolerance resistor values can be used. If the calculation results in a negative value for C2 or an unrealistically large value for C1, then the phase margin must be reduced slightly.

Revision History

Changes from Revision E (June 2006) to Revision F	Page
• Changed DA[15:0] pin description	5
• Changed DB[15:0] pin description	5
• Changed PHSTR pin description	5
• Changed QFLAG pin description	5
• Changed RESETB pin description	5
• Changed SCLK pin description	5
• Changed SDENB pin description	5
• Changed SDIO pin description	6
• made changes per input markup	18
• Changed terms in Equation 1	18
• Changed signs of inputs and formula for lower DAC in Figure 20	19
• Made corrections to Equation 2 and Equation 3	21
• Added values to resistors in Figure 45	43
• Swapped definitions of IOOUT1 and IOOUT2 in the corresponding equations	45

Changes from Revision D (January 2006) to Revision E	Page
• For QFLAG description, changed O to I and output to input	5
• Changed QFLAG description from output to input	32
• New paragraph describing problem with synchronization in PLL clock mode with interleaved input	32
• Added "by the user as an input indicator" to first sentence of qflag register description	41

PACKAGING INFORMATION

Orderable Device	Status (1)	Package Type	Package Drawing	Pins	Package Qty	Eco Plan (2)	Lead/Ball Finish	MSL Peak Temp (3)	Op Temp (°C)	Top-Side Markings (4)	Samples
DAC5686IPZP	ACTIVE	HTQFP	PZP	100	90	Green (RoHS & no Sb/Br)	CU NIPDAU	Level-3-260C-168 HR	-40 to 85	DAC5686IPZP	Samples
DAC5686IPZPG4	ACTIVE	HTQFP	PZP	100	90	Green (RoHS & no Sb/Br)	CU NIPDAU	Level-3-260C-168 HR	-40 to 85	DAC5686IPZP	Samples

(1) The marketing status values are defined as follows:

ACTIVE: Product device recommended for new designs.

LIFEBUY: TI has announced that the device will be discontinued, and a lifetime-buy period is in effect.

NRND: Not recommended for new designs. Device is in production to support existing customers, but TI does not recommend using this part in a new design.

PREVIEW: Device has been announced but is not in production. Samples may or may not be available.

OBSOLETE: TI has discontinued the production of the device.

(2) Eco Plan - The planned eco-friendly classification: Pb-Free (RoHS), Pb-Free (RoHS Exempt), or Green (RoHS & no Sb/Br) - please check <http://www.ti.com/productcontent> for the latest availability information and additional product content details.

TBD: The Pb-Free/Green conversion plan has not been defined.

Pb-Free (RoHS): TI's terms "Lead-Free" or "Pb-Free" mean semiconductor products that are compatible with the current RoHS requirements for all 6 substances, including the requirement that lead not exceed 0.1% by weight in homogeneous materials. Where designed to be soldered at high temperatures, TI Pb-Free products are suitable for use in specified lead-free processes.

Pb-Free (RoHS Exempt): This component has a RoHS exemption for either 1) lead-based flip-chip solder bumps used between the die and package, or 2) lead-based die adhesive used between the die and leadframe. The component is otherwise considered Pb-Free (RoHS compatible) as defined above.

Green (RoHS & no Sb/Br): TI defines "Green" to mean Pb-Free (RoHS compatible), and free of Bromine (Br) and Antimony (Sb) based flame retardants (Br or Sb do not exceed 0.1% by weight in homogeneous material)

(3) MSL, Peak Temp. -- The Moisture Sensitivity Level rating according to the JEDEC industry standard classifications, and peak solder temperature.

(4) Multiple Top-Side Markings will be inside parentheses. Only one Top-Side Marking contained in parentheses and separated by a "~" will appear on a device. If a line is indented then it is a continuation of the previous line and the two combined represent the entire Top-Side Marking for that device.

Important Information and Disclaimer: The information provided on this page represents TI's knowledge and belief as of the date that it is provided. TI bases its knowledge and belief on information provided by third parties, and makes no representation or warranty as to the accuracy of such information. Efforts are underway to better integrate information from third parties. TI has taken and continues to take reasonable steps to provide representative and accurate information but may not have conducted destructive testing or chemical analysis on incoming materials and chemicals. TI and TI suppliers consider certain information to be proprietary, and thus CAS numbers and other limited information may not be available for release.

In no event shall TI's liability arising out of such information exceed the total purchase price of the TI part(s) at issue in this document sold by TI to Customer on an annual basis.

MECHANICAL DATA

PZP (S-PQFP-G100)

PowerPAD™ PLASTIC QUAD FLATPACK

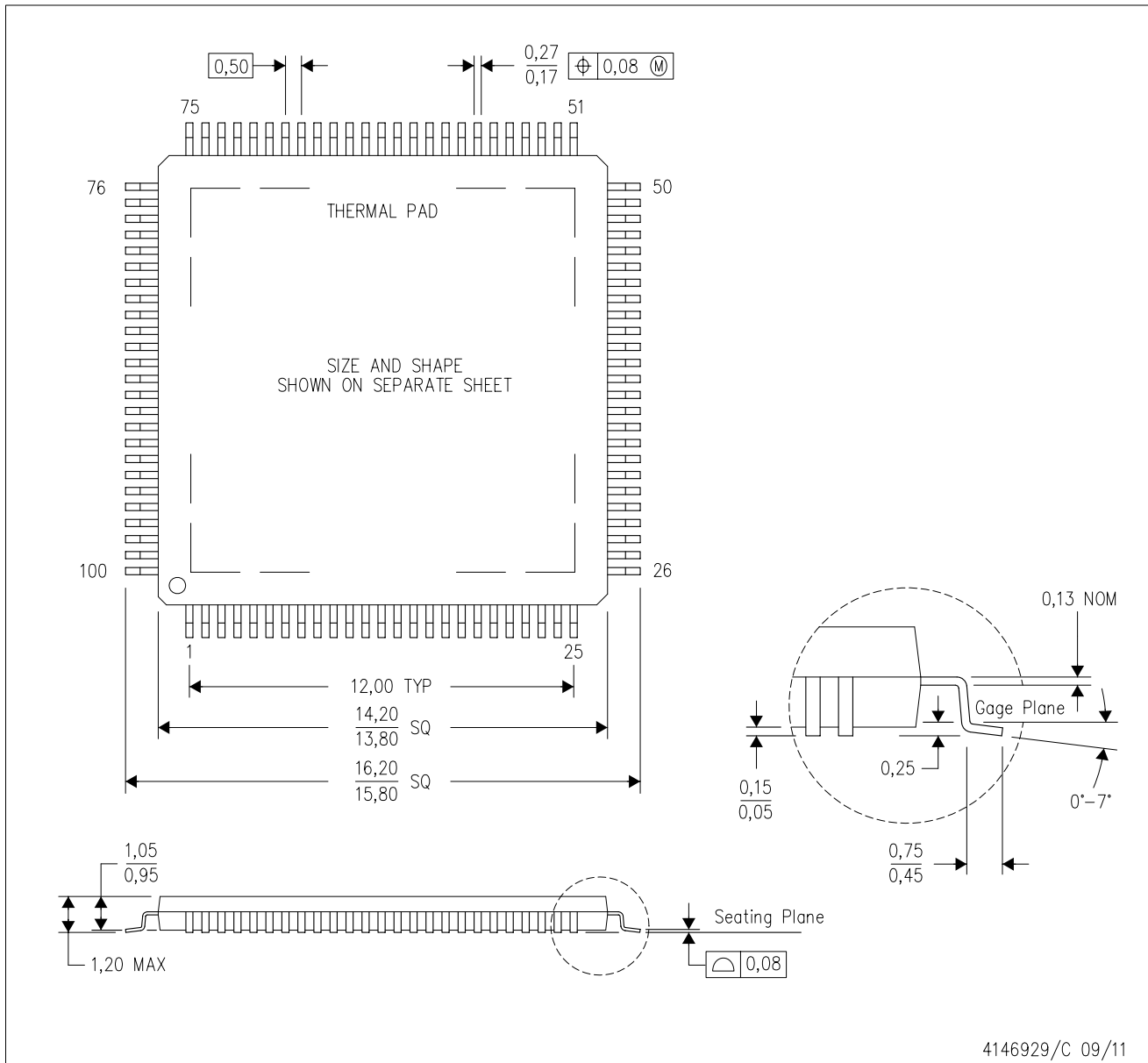

- NOTES:
- A. All linear dimensions are in millimeters.
 - B. This drawing is subject to change without notice.
 - C. Body dimensions do not include mold flash or protrusion
 - D. This package is designed to be soldered to a thermal pad on the board. Refer to Technical Brief, PowerPad Thermally Enhanced Package, Texas Instruments Literature No. SLMA002 for information regarding recommended board layout. This document is available at www.ti.com <<http://www.ti.com>>.
 - E. See the additional figure in the Product Data Sheet for details regarding the exposed thermal pad features and dimensions.
 - F. Falls within JEDEC MS-026

PowerPAD is a trademark of Texas Instruments.

THERMAL PAD MECHANICAL DATA

PZP (S-PQFP-G100)

PowerPAD™ PLASTIC QUAD FLATPACK

THERMAL INFORMATION

This PowerPAD™ package incorporates an exposed thermal pad that is designed to be attached to a printed circuit board (PCB). The thermal pad must be soldered directly to the PCB. After soldering, the PCB can be used as a heatsink. In addition, through the use of thermal vias, the thermal pad can be attached directly to the appropriate copper plane shown in the electrical schematic for the device, or alternatively, can be attached to a special heatsink structure designed into the PCB. This design optimizes the heat transfer from the integrated circuit (IC).

For additional information on the PowerPAD package and how to take advantage of its heat dissipating abilities, refer to Technical Brief, PowerPAD Thermally Enhanced Package, Texas Instruments Literature No. SLMA002 and Application Brief, PowerPAD Made Easy, Texas Instruments Literature No. SLMA004. Both documents are available at www.ti.com.

The exposed thermal pad dimensions for this package are shown in the following illustration.

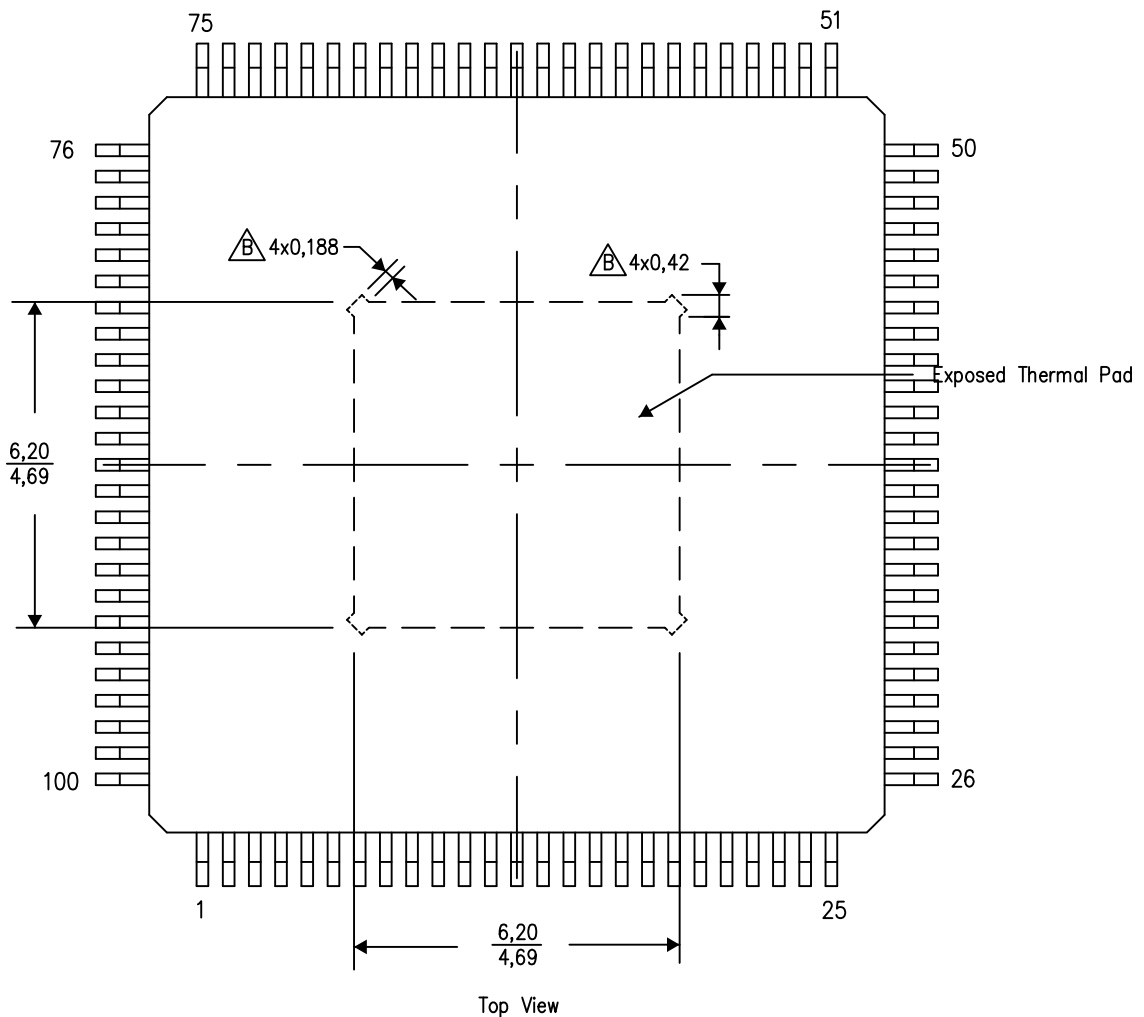

Exposed Thermal Pad Dimensions

4206333-3/L 05/14

NOTE: A. All linear dimensions are in millimeters

 Tie strap features may not be present.

PowerPAD is a trademark of Texas Instruments

IMPORTANT NOTICE FOR TI DESIGN INFORMATION AND RESOURCES

Texas Instruments Incorporated ("TI") technical, application or other design advice, services or information, including, but not limited to, reference designs and materials relating to evaluation modules, (collectively, "TI Resources") are intended to assist designers who are developing applications that incorporate TI products; by downloading, accessing or using any particular TI Resource in any way, you (individually or, if you are acting on behalf of a company, your company) agree to use it solely for this purpose and subject to the terms of this Notice.

TI's provision of TI Resources does not expand or otherwise alter TI's applicable published warranties or warranty disclaimers for TI products, and no additional obligations or liabilities arise from TI providing such TI Resources. TI reserves the right to make corrections, enhancements, improvements and other changes to its TI Resources.

You understand and agree that you remain responsible for using your independent analysis, evaluation and judgment in designing your applications and that you have full and exclusive responsibility to assure the safety of your applications and compliance of your applications (and of all TI products used in or for your applications) with all applicable regulations, laws and other applicable requirements. You represent that, with respect to your applications, you have all the necessary expertise to create and implement safeguards that (1) anticipate dangerous consequences of failures, (2) monitor failures and their consequences, and (3) lessen the likelihood of failures that might cause harm and take appropriate actions. You agree that prior to using or distributing any applications that include TI products, you will thoroughly test such applications and the functionality of such TI products as used in such applications. TI has not conducted any testing other than that specifically described in the published documentation for a particular TI Resource.

You are authorized to use, copy and modify any individual TI Resource only in connection with the development of applications that include the TI product(s) identified in such TI Resource. NO OTHER LICENSE, EXPRESS OR IMPLIED, BY ESTOPPEL OR OTHERWISE TO ANY OTHER TI INTELLECTUAL PROPERTY RIGHT, AND NO LICENSE TO ANY TECHNOLOGY OR INTELLECTUAL PROPERTY RIGHT OF TI OR ANY THIRD PARTY IS GRANTED HEREIN, including but not limited to any patent right, copyright, mask work right, or other intellectual property right relating to any combination, machine, or process in which TI products or services are used. Information regarding or referencing third-party products or services does not constitute a license to use such products or services, or a warranty or endorsement thereof. Use of TI Resources may require a license from a third party under the patents or other intellectual property of the third party, or a license from TI under the patents or other intellectual property of TI.

TI RESOURCES ARE PROVIDED "AS IS" AND WITH ALL FAULTS. TI DISCLAIMS ALL OTHER WARRANTIES OR REPRESENTATIONS, EXPRESS OR IMPLIED, REGARDING TI RESOURCES OR USE THEREOF, INCLUDING BUT NOT LIMITED TO ACCURACY OR COMPLETENESS, TITLE, ANY EPIDEMIC FAILURE WARRANTY AND ANY IMPLIED WARRANTIES OF MERCHANTABILITY, FITNESS FOR A PARTICULAR PURPOSE, AND NON-INFRINGEMENT OF ANY THIRD PARTY INTELLECTUAL PROPERTY RIGHTS.

TI SHALL NOT BE LIABLE FOR AND SHALL NOT DEFEND OR INDEMNIFY YOU AGAINST ANY CLAIM, INCLUDING BUT NOT LIMITED TO ANY INFRINGEMENT CLAIM THAT RELATES TO OR IS BASED ON ANY COMBINATION OF PRODUCTS EVEN IF DESCRIBED IN TI RESOURCES OR OTHERWISE. IN NO EVENT SHALL TI BE LIABLE FOR ANY ACTUAL, DIRECT, SPECIAL, COLLATERAL, INDIRECT, PUNITIVE, INCIDENTAL, CONSEQUENTIAL OR EXEMPLARY DAMAGES IN CONNECTION WITH OR ARISING OUT OF TI RESOURCES OR USE THEREOF, AND REGARDLESS OF WHETHER TI HAS BEEN ADVISED OF THE POSSIBILITY OF SUCH DAMAGES.

You agree to fully indemnify TI and its representatives against any damages, costs, losses, and/or liabilities arising out of your non-compliance with the terms and provisions of this Notice.

This Notice applies to TI Resources. Additional terms apply to the use and purchase of certain types of materials, TI products and services. These include; without limitation, TI's standard terms for semiconductor products (<http://www.ti.com/sc/docs/stdterms.htm>), [evaluation modules](#), and [samples](http://www.ti.com/sc/docs/sampterm.htm) (<http://www.ti.com/sc/docs/sampterm.htm>).

Mailing Address: Texas Instruments, Post Office Box 655303, Dallas, Texas 75265
Copyright © 2017, Texas Instruments Incorporated

Looking for pricing, stock, or lifecycle information?

Click below to explore more details on WIN SOURCE:

 [View DAC5686IPZP on WIN SOURCE](#)

 [Texas Instruments](#) Information

Optimize Your Supply Chain with WIN SOURCE Solutions

-  Global Sourcing Solution
-  Obsolete Management
-  Cost Control Management
-  Shortage Management
-  Alternative Solution
-  Excess Inventory Management