



# THE DATASHEET OF DAC5652AIPFBR



## DAC5652A Dual, 10-Bit, 275-MSPS Digital-to-Analog Converter

### 1 Features

- 10-Bit Dual Transmit DAC
- 275 MSPS Update Rate
- Single Supply: 3.0 V to 3.6 V
- High Spurious-Free Dynamic Range (SFDR): 80 dBc at 5 MHz
- High Third-Order Two-Tone Intermodulation (IMD3): 78 dBc at 15.1 MHz and 16.1 MHz
- Independent or Single Resistor Gain Control
- Dual or Interleaved Data
- On-Chip 1.2-V Reference
- Low Power: 290 mW
- Power-Down Mode: 9 mW
- Packages:
  - 48-Pin Thin-Quad Flat Pack (TQFP)
  - 48-Pin Very-Thin-Quad Flat No-Leads (VQFN)

### 2 Applications

- Cellular Base Transceiver Station Transmit Channel
  - CDMA: W-CDMA, CDMA2000, IS-95
  - TDMA: GSM, IS-136, EDGE/UWC-136
- Medical/Test Instrumentation
- Arbitrary Waveform Generators (ARB)
- Direct Digital Synthesis (DDS)
- Cable Modem Termination System (CMTS)

### 3 Description

The DAC5652A is a monolithic, dual-channel, 10-bit, high-speed digital-to-analog converter (DAC) with on-chip voltage reference.

Operating with update rates of up to 275 MSPS, the DAC5652A offers exceptional dynamic performance, tight-gain, and offset matching characteristics that make it suitable in either I/Q baseband or direct IF communication applications.

Each DAC has a high-impedance, differential-current output, suitable for single-ended or differential analog-output configurations. External resistors allow scaling of the full-scale output current for each DAC separately or together, typically between 2 mA and 20 mA. An accurate on-chip voltage reference is temperature-compensated and delivers a stable 1.2-V reference voltage. Optionally, an external reference may be used.

The DAC5652A has two, 10-bit, parallel input ports with separate clocks and data latches. For flexibility, the DAC5652A also supports multiplexed data for each DAC on one port when operating in the interleaved mode.

The DAC5652A has been specifically designed for a differential transformer-coupled output with a 50-Ω doubly-terminated load. For a 20-mA full-scale output current, both a 4:1 impedance ratio (resulting in an output power of 4 dBm) and 1:1 impedance ratio transformer (–2-dBm output power) are supported.

The DAC5652A is available in 48-pin TQFP and 48-pin VQFN packages. The TQFP package offers pin compatibility between family members that provides 10-bit (DAC5652A), 12-bit (DAC5662), and 14-bit (DAC5672) resolution. The TQFP package is also pin compatible to the DAC2900 and AD9763 dual DACs. The device is characterized for operation over the industrial temperature range of –40°C to +85°C.

Functional Block Diagram

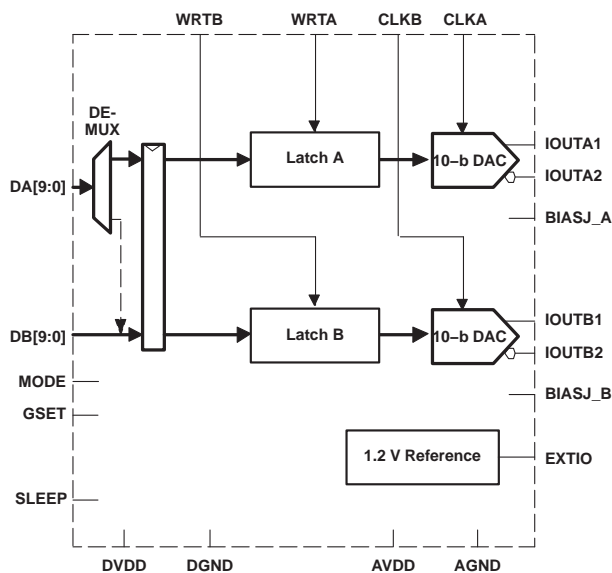

Device Information<sup>(1)</sup>

PART NUMBER	PACKAGE	BODY SIZE (NOM)
DAC5652A	TQFP (48)	7 mm × 7 mm
	VQFN (48)	6 mm × 6 mm

(1) For all available packages, see the package option addendum at the end of the data sheet.



## Table of Contents

<b>1 Features</b> ..... 1 <b>2 Applications</b> ..... 1 <b>3 Description</b> ..... 1 <b>4 Revision History</b> ..... 2 <b>5 Pin Configuration and Functions</b> ..... 4 <b>6 Specifications</b> ..... 6 6.1 Absolute Maximum Ratings ..... 6 6.2 ESD Ratings ..... 6 6.3 Recommended Operating Conditions ..... 6 6.4 Thermal Information ..... 6 6.5 Electrical Characteristics: DC ..... 7 6.6 Electrical Characteristics: AC ..... 8 6.7 Electrical Characteristics: Digital Input ..... 9 6.8 Electrical Characteristics: Power Supply ..... 9 6.9 Switching Characteristics ..... 9 6.10 Typical Characteristics ..... 10 <b>7 Detailed Description</b> ..... 12 7.1 Overview ..... 12	7.2 Functional Block Diagram ..... 12 7.3 Feature Description ..... 13 7.4 Device Functional Modes ..... 15 <b>8 Application and Implementation</b> ..... 18 8.1 Application Information ..... 18 8.2 Typical Application ..... 22 <b>9 Power Supply Recommendations</b> ..... 23 <b>10 Layout</b> ..... 23 10.1 Layout Guidelines ..... 23 10.2 Layout Examples ..... 24 <b>11 Device and Documentation Support</b> ..... 27 11.1 Documentation Support ..... 27 11.2 Receiving Notification of Documentation Updates ..... 27 11.3 Community Resources ..... 27 11.4 Trademarks ..... 27 11.5 Electrostatic Discharge Caution ..... 27 11.6 Glossary ..... 27 <b>12 Mechanical, Packaging, and Orderable Information</b> ..... 27
--	--

## 4 Revision History

NOTE: Page numbers for previous revisions may differ from page numbers in the current version.

Changes from Revision E (May 2018) to Revision F	Page
• Added VQFN package text to <i>Description</i> section ..... 1	1
• Changed text in <i>Description</i> section to clarify that pin compatibility is only available for TQFP package ..... 1	1
Changes from Revision D (August 2012) to Revision E	Page
• Added <i>Device Information</i> , <i>ESD Ratings</i> , <i>Recommended Operating Conditions</i> tables; and <i>Detailed Description</i> , <i>Applications and Implementation</i> , <i>Power-Supply Recommendations</i> , <i>Layout</i> , <i>Device and Documentation Support</i> , and <i>Mechanical, Packaging, and Orderable Information</i> sections; existing content moved to new sections ..... 1	1
• Added new VQFN-48 package and associated content ..... 1	1
Changes from Revision C (June 2011) to Revision D	Page
• Deleted the $V_{IH}$ MAX value of 3.3 V ..... 9	9
• Deleted the $V_{IL}$ MIN value of 0 V ..... 9	9
Changes from Revision B (December 2010) to Revision C	Page
• Added <i>Thermal Information</i> table ..... 6	6
Changes from Revision A (May 2009) to Revision B	Page
• Changed the non-printing $\mu$ symbols in the <i>Digital Input</i> section of the <i>Electrical Characteristics</i> table (units column) to the correct $\mu$ symbols recognized by the PDF processor ..... 9	9

---

**Changes from Original (September 2007) to Revision A****Page**

• Added internal pulldown to DA and DB pin descriptions.....	5
• Added GSET to <i>Absolute Maximum Ratings</i> table.....	6
• Added "The pullup and pulldown circuitry is approximately equivalent to 100 k $\Omega$ " to <i>Digital Inputs</i> section .....	13
• Added resistor values to Figure 13.....	13
• Added resistor values to Figure 14.....	13

---

# DAC5652A

SLAS535F – SEPTEMBER 2007 – REVISED OCTOBER 2018

www.ti.com

## 5 Pin Configuration and Functions

**PFB Package  
48-Pin TQFP  
Top View**

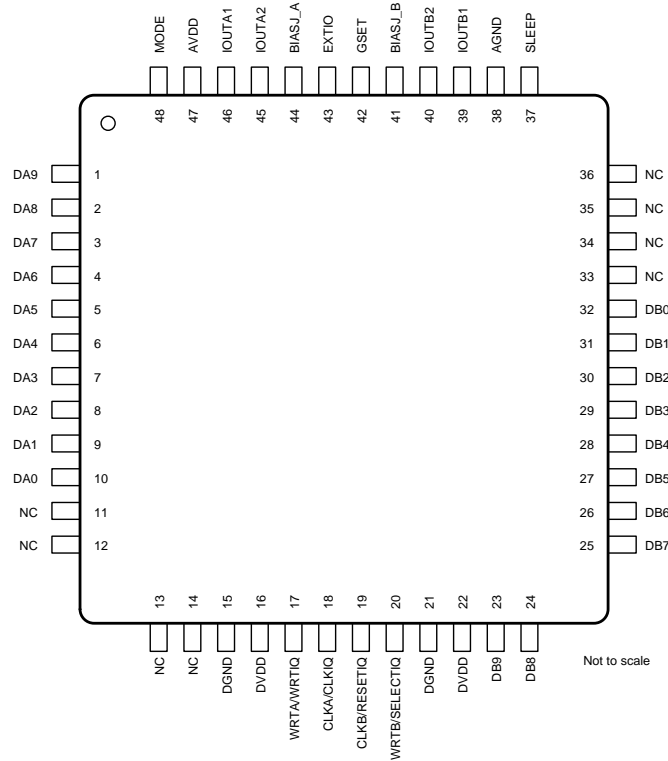

**RSL Package  
48-Pin VQFN  
Top View**

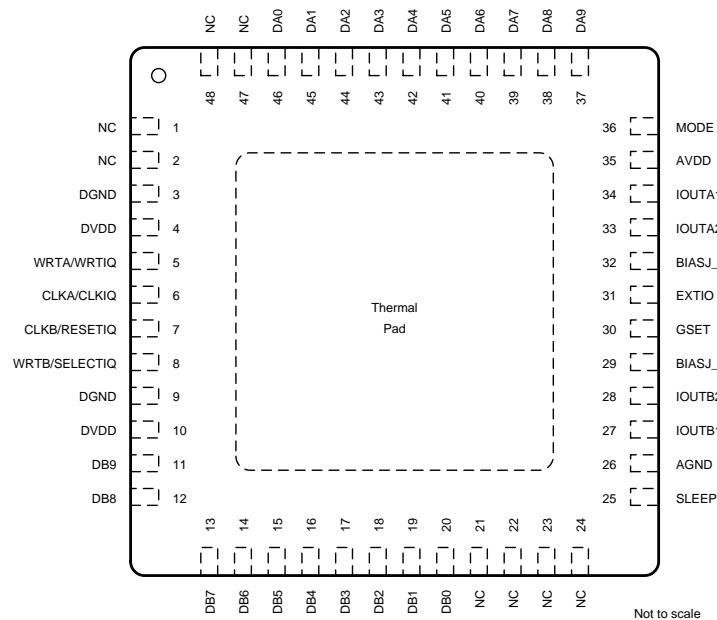

**Pin Functions**

PIN			I/O	DESCRIPTION
NAME	TQFP	VQFN		
AGND	38	26	I	Analog ground
AVDD	47	35	I	Analog supply voltage
BIASJ_A	44	32	O	Full-scale output current bias for DACA
BIASJ_B	41	29	O	Full-scale output current bias for DACB
CLKA/CLKIQ	18	6	I	Clock input for DACA, CLKIQ in interleaved mode
CLKB/RESETIQ	19	7	I	Clock input for DACB, RESETIQ in interleaved mode
DA0	10	46	I	Data port A0 (LSB). Internal pull-down.
DA1	9	45	I	Data port A1. Internal pull-down.
DA2	8	44	I	Data port A2. Internal pull-down.
DA3	7	43	I	Data port A3. Internal pull-down.
DA4	6	42	I	Data port A4. Internal pull-down.
DA5	5	41	I	Data port A5. Internal pull-down.
DA6	4	40	I	Data port A6. Internal pull-down.
DA7	3	39	I	Data port A7. Internal pull-down.
DA8	2	38	I	Data port A8. Internal pull-down.
DA9	1	37	i	Data port A9 (MSB). Internal pull-down.
DB0	32	20	I	Data port B0 (LSB). Internal pull-down.
DB1	31	19	I	Data port B1. Internal pull-down.
DB2	30	18	I	Data port B2. Internal pull-down.
DB3	29	17	I	Data port B3. Internal pull-down.
DB4	28	16	I	Data port B4. Internal pull-down.
DB5	27	15	I	Data port B5. Internal pull-down.
DB6	26	14	I	Data port B6. Internal pull-down.
DB7	25	13	I	Data port B7. Internal pull-down.
DB8	24	12	I	Data port B8. Internal pull-down.
DB9	23	11	I	Data port B9 (MSB). Internal pull-down.
DGND	15, 21	3, 9	I	Digital ground
DVDD	16, 22	4, 10	I	Digital supply voltage
EXTIO	43	31	I/O	Internal reference output (bypass with 0.1 $\mu$ F to AGND) or external reference input
GSET	42	30	I	Gain-setting mode: H – 1 resistor, L – 2 resistors. Internal pullup.
IOUTA1	46	34	O	DACA current output. Full-scale with all bits of DA high.
IOUTA2	45	33	O	DACA complementary current output. Full-scale with all bits of DA low.
IOUTB1	39	27	O	DACB current output. Full-scale with all bits of DB high.
IOUTB2	40	28	O	DACB complementary current output. Full-scale with all bits of DB low.
MODE	48	36	I	Mode Select: H – Dual Bus, L – Interleaved. Internal pullup.
NC	11-14, 33-36	1,2, 21-24, 47, 48	—	Factory use only. Pins must be connected to DGND or left unconnected.
SLEEP	37	25	I	Sleep function control input: H – DAC in power-down mode, L – DAC in operating mode. Internal pull-down.
WRTA/WRTIQ	17	5	I	Input write signal for PORT A (WRTIQ in interleaving mode)
WRTB/SELECTIQ	20	8	I	Input write signal for PORT B (SELECTIQ in interleaving mode)

## 6 Specifications

### 6.1 Absolute Maximum Ratings

over operating free-air temperature range (unless otherwise noted)<sup>(1)</sup>

		MIN	MAX	UNIT
Voltage	AVDD (measured with respect to AGND)	-0.5	4	V
	DVDD (measured with respect to DGND)	-0.5	4	
	Between AGND and DGND	-0.5	0.5	
	Between AVDD and DVDD	-4	4	
	DA[9:0] and DB[9:0]	-0.5	DVDD + 0.5	
	MODE, SLEEP, CLKA, CLKB, WRTA, WRTB	-0.5	DVDD + 0.5	
	IOUTA1, IOUTA2, IOUTB1, IOUTB2	-1	AVDD + 0.5	
	EXTIO, BIASJ_A, BIASJ_B, GSET	-0.5	AVDD + 0.5	
Current	Peak input current (any input)		20	mA
	Peak total input current (all inputs)		-30	
Temperature	Operating free-air, T <sub>A</sub>	-40	85	°C
	Storage, T <sub>stg</sub>	-65	150	°C

(1) Stresses beyond those listed under *Absolute Maximum Ratings* may cause permanent damage to the device. These are stress ratings only, which do not imply functional operation of the device at these or any other conditions beyond those indicated under *Recommended Operating Conditions*. Exposure to absolute-maximum-rated conditions for extended periods may affect device reliability.

### 6.2 ESD Ratings

		VALUE	UNIT
V <sub>(ESD)</sub>	Electrostatic discharge	Human-body model (HBM), per ANSI/ESDA/JEDEC JS-001 <sup>(1)</sup>	±2000
		Charged-device model (CDM), per JEDEC specification JESD22-C101 <sup>(2)</sup>	±1000

(1) JEDEC document JEP155 states that 500-V HBM allows safe manufacturing with a standard ESD control process.

(2) JEDEC document JEP157 states that 250-V CDM allows safe manufacturing with a standard ESD control process.

### 6.3 Recommended Operating Conditions

		MIN	NOM	MAX	UNIT
AVDD	Analog supply voltage	3	3.3	3.6	V
DVDD	Digital supply voltage	3	3.3	3.6	V
	Output voltage compliance range <sup>(1)</sup>	-1		1.25	V
	Clock input frequency			275	MHz
T <sub>A</sub>	Operating free-air temperature	-40		85	°C

(1) The lower limit of the output compliance is determined by the CMOS process. Exceeding this limit may result in transistor breakdown, resulting in reduced reliability of the DAC5652A device. The upper limit of the output compliance is determined by the load resistors and full-scale output current. Exceeding the upper limit adversely affects distortion performance and integral nonlinearity.

### 6.4 Thermal Information

THERMAL METRIC <sup>(1)</sup>	DAC5652A		UNIT	
	PFB (TQFP)	RSL (VQFN)		
	48 PINS	48 PINS		
R <sub>θJA</sub>	Junction-to-ambient thermal resistance	65.3	27.0	°C/W
R <sub>θJC(top)</sub>	Junction-to-case (top) thermal resistance	16.4	17.3	°C/W
R <sub>θJB</sub>	Junction-to-board thermal resistance	28.6	9.6	°C/W
ψ <sub>JT</sub>	Junction-to-top characterization parameter	0.4	0.2	°C/W
ψ <sub>JB</sub>	Junction-to-board characterization parameter	28.4	9.6	°C/W
R <sub>θJC(bot)</sub>	Junction-to-case (bottom) thermal resistance	N/A	2.2	°C/W

(1) For information about traditional and new thermal metrics, see the [Semiconductor and IC Package Thermal Metrics](#) application report.

## 6.5 Electrical Characteristics: DC

dc specifications over  $T_A$ ,  $AVDD = DVDD = 3.3\text{ V}$ ,  $I_{(OUTFS)} = 20\text{ mA}$ , and independent gain set mode (unless otherwise noted)

PARAMETER		TEST CONDITIONS	MIN	TYP	MAX	UNIT
<b>RESOLUTION</b>						
Resolution			10			Bits
<b>DC ACCURACY<sup>(1)</sup></b>						
INL	Integral nonlinearity	$1\text{ LSB} = I_{(OUTFS)}/2^{10}$ , $T_{MIN}$ to $T_{MAX}$	-1	$\pm 0.25$	1	LSB
DNL	Differential nonlinearity		-0.5	$\pm 0.16$	0.5	LSB
<b>ANALOG OUTPUT</b>						
Offset error		Midscale value (internal reference)		$\pm 0.05$		%FSR
Offset mismatch		Midscale value (internal reference)		$\pm 0.03$		%FSR
Gain error		With internal reference		$\pm 0.75$		%FSR
Minimum full-scale output current <sup>(2)</sup>				2		mA
Maximum full-scale output current <sup>(2)</sup>				20		mA
Gain mismatch		With internal reference	-2	0.2	2	%FSR
Output voltage compliance range <sup>(3)</sup>			-1		1.25	V
$R_O$	Output resistance			300		k $\Omega$
$C_O$	Output capacitance			5		pF
<b>REFERENCE OUTPUT</b>						
Reference voltage			1.14	1.2	1.26	V
Reference output current <sup>(4)</sup>				100		nA
<b>REFERENCE INPUT</b>						
$V_{(EXTIO)}$	Input voltage		0.1		1.25	V
$R_I$	Input resistance			1		M $\Omega$
Small signal bandwidth				300		kHz
$C_I$	Input capacitance			100		pF
<b>TEMPERATURE COEFFICIENTS</b>						
Offset drift				2		ppm of FSR/ $^{\circ}\text{C}$
Gain drift		With external reference		$\pm 20$		ppm of FSR/ $^{\circ}\text{C}$
		With internal reference		$\pm 40$		
Reference voltage drift				$\pm 20$		ppm/ $^{\circ}\text{C}$

(1) Measured differentially through  $50\ \Omega$  to AGND.

(2) Nominal full-scale current,  $I_{(OUTFS)}$ , equals  $32\times$  the  $I_{(BIAS)}$  current.

(3) The lower limit of the output compliance is determined by the CMOS process. Exceeding this limit may result in transistor breakdown, resulting in reduced reliability of the DAC5652A device. The upper limit of the output compliance is determined by the load resistors and full-scale output current. Exceeding the upper limit adversely affects distortion performance and integral nonlinearity.

(4) Use an external buffer amplifier with high-impedance input to drive any external load.

## 6.6 Electrical Characteristics: AC

ac specifications over  $T_A$ ,  $AVDD = DVDD = 3.3\text{ V}$ ,  $I_{(OUTFS)} = 20\text{ mA}$ , independent gain set mode, differential 1:1 impedance ratio transformer coupled output, and 50- $\Omega$  doubly terminated load (unless otherwise noted)

PARAMETER		TEST CONDITIONS	MIN	TYP	MAX	UNIT
<b>ANALOG OUTPUT</b>						
$f_{\text{clk}}$	Maximum output update rate <sup>(1)</sup>		275			MSPS
$t_s$	Output settling time to 0.1% (DAC)	Midscale transition		20		ns
$t_r$	Output rise time 10% to 90% (OUT)			1.4		ns
$t_f$	Output fall time 90% to 10% (OUT)			1.5		ns
	Output noise	$I_{(OUTFS)} = 20\text{ mA}$		55		pA/ $\sqrt{\text{Hz}}$
		$I_{(OUTFS)} = 2\text{ mA}$		30		
<b>AC LINEARITY</b>						
SFDR	Spurious-free dynamic range	1st Nyquist zone, $T_A = 25^\circ\text{C}$ , $f_{\text{DATA}} = 50\text{ MSPS}$ , $f_{\text{OUT}} = 1\text{ MHz}$ , $I_{(OUTFS)} = 0\text{ dB}$		79		dBc
		1st Nyquist zone, $T_A = 25^\circ\text{C}$ , $f_{\text{DATA}} = 50\text{ MSPS}$ , $f_{\text{OUT}} = 1\text{ MHz}$ , $I_{(OUTFS)} = -6\text{ dB}$		78		
		1st Nyquist zone, $T_A = 25^\circ\text{C}$ , $f_{\text{DATA}} = 50\text{ MSPS}$ , $f_{\text{OUT}} = 1\text{ MHz}$ , $I_{(OUTFS)} = -12\text{ dB}$		73		
		1st Nyquist zone, $T_A = 25^\circ\text{C}$ , $f_{\text{DATA}} = 100\text{ MSPS}$ , $f_{\text{OUT}} = 5\text{ MHz}$ , $I_{(OUTFS)} = 0\text{ dB}$		80		
		1st Nyquist zone, $T_A = 25^\circ\text{C}$ , $f_{\text{DATA}} = 100\text{ MSPS}$ , $f_{\text{OUT}} = 20\text{ MHz}$ , $I_{(OUTFS)} = 0\text{ dB}$		76		
		1st Nyquist zone, $T_{\text{MIN}}$ to $T_{\text{MAX}}$ , $f_{\text{DATA}} = 200\text{ MSPS}$ , $f_{\text{OUT}} = 20\text{ MHz}$ , $I_{(OUTFS)} = 0\text{ dB}$	61	70		
		1st Nyquist zone, $T_A = 25^\circ\text{C}$ , $f_{\text{DATA}} = 200\text{ MSPS}$ , $f_{\text{OUT}} = 41\text{ MHz}$ , $I_{(OUTFS)} = 0\text{ dB}$		67		
		1st Nyquist zone, $T_A = 25^\circ\text{C}$ , $f_{\text{DATA}} = 275\text{ MSPS}$ , $f_{\text{OUT}} = 20\text{ MHz}$		70		
SNR	Signal-to-noise ratio	1st Nyquist zone, $T_A = 25^\circ\text{C}$ , $f_{\text{DATA}} = 100\text{ MSPS}$ , $f_{\text{OUT}} = 5\text{ MHz}$ , $I_{(OUTFS)} = 0\text{ dB}$		63		dB
		1st Nyquist zone, $T_A = 25^\circ\text{C}$ , $f_{\text{DATA}} = 160\text{ MSPS}$ , $f_{\text{OUT}} = 20\text{ MHz}$ , $I_{(OUTFS)} = 0\text{ dB}$		62		dB
IMD3	Third-order two-tone intermodulation	Each tone at $-6\text{ dBFS}$ , $T_A = 25^\circ\text{C}$ , $f_{\text{DATA}} = 200\text{ MSPS}$ , $f_{\text{OUT}} = 45.4\text{ MHz}$ and $46.4\text{ MHz}$		61		dBc
		Each tone at $-6\text{ dBFS}$ , $T_A = 25^\circ\text{C}$ , $f_{\text{DATA}} = 100\text{ MSPS}$ , $f_{\text{OUT}} = 15.1\text{ MHz}$ and $16.1\text{ MHz}$		78		
IMD	Four-tone intermodulation	Each tone at $-12\text{ dBFS}$ , $T_A = 25^\circ\text{C}$ , $f_{\text{DATA}} = 100\text{ MSPS}$ , $f_{\text{OUT}} = 15.6, 15.8, 16.2,$ and $16.4\text{ MHz}$		76		dBc
		Each tone at $-12\text{ dBFS}$ , $T_A = 25^\circ\text{C}$ , $f_{\text{DATA}} = 165\text{ MSPS}$ , $f_{\text{OUT}} = 19.0, 19.1, 19.3,$ and $19.4\text{ MHz}$		55		
		Each tone at $-12\text{ dBFS}$ , $T_A = 25^\circ\text{C}$ , $f_{\text{DATA}} = 165\text{ MSPS}$ , $f_{\text{OUT}} = 68.8, 69.6, 71.2,$ and $72.0\text{ MHz}$		70		
	Channel isolation	$T_A = 25^\circ\text{C}$ , $f_{\text{DATA}} = 165\text{ MSPS}$ , $f_{\text{OUT}}(\text{CH1}) = 20\text{ MHz}$ , $f_{\text{OUT}}(\text{CH2}) = 21\text{ MHz}$		90		dBc

(1) Specified by design and bench characterization. Not production tested.

## 6.7 Electrical Characteristics: Digital Input

digital specifications over  $T_A$ ,  $AVDD = DVDD = 3.3\text{ V}$ , and  $I_{(OUTFS)} = 20\text{ mA}$  (unless otherwise noted)

PARAMETER	TEST CONDITIONS	MIN	TYP	MAX	UNIT
$V_{IH}$	High-level input voltage	2			V
$V_{IL}$	Low-level input voltage			0.8	V
$I_{IH}$	High-level input current		±50		μA
$I_{IL}$	Low-level input current		±10		μA
$I_{IH(GSET)}$	High-level input current, GSET pin		7		μA
$I_{IL(GSET)}$	Low-level input current, GSET pin		-80		μA
$I_{IH(MODE)}$	High-level input current, MODE pin		-30		μA
$I_{IL(MODE)}$	Low-level input current, MODE pin		-80		μA
$C_I$	Input capacitance		5		pF

## 6.8 Electrical Characteristics: Power Supply

power supply specifications over  $T_A$ ,  $AVDD = DVDD = 3.3\text{ V}$ ,  $I_{(OUTFS)} = 20\text{ mA}$ ,  $f_{DATA} = 200\text{ MSPS}$ ,  $f_{OUT} = 1\text{ MHz}$ , and independent gain set mode (unless otherwise noted)

PARAMETER	TEST CONDITIONS	MIN	TYP	MAX	UNIT
$I_{(AVDD)}$	Supply current, analog		75	90	mA
	Including output current through load resistor				
	Sleep mode with clock		2.5		
	Sleep mode without clock		2.5		
$I_{(DVDD)}$	Supply current, digital		12	20	mA
	Sleep mode with clock		11.3	18	
	Sleep mode without clock		0.6		
Power dissipation			290	360	mW
	Sleep mode with clock		45.5		
	Sleep mode without clock		9.2		
	$f_{DATA} = 275\text{ MSPS}$ , $f_{OUT} = 20\text{ MHz}$		310		
APSR	Analog power supply rejection ratio	-0.2	-0.01	0.2	%FSR/V
DPSRR	Digital power supply rejection ratio	-0.2	0	0.2	%FSR/V

## 6.9 Switching Characteristics

digital specifications over  $T_A$ ,  $AVDD = DVDD = 3.3\text{ V}$ , and  $I_{(OUTFS)} = 20\text{ mA}$  (unless otherwise noted)

PARAMETER	TEST CONDITIONS	MIN	TYP	MAX	UNIT
<b>TIMING - DUAL BUS MODE</b>					
$t_{su}$	Input setup time	1			ns
$t_h$	Input hold time	1			ns
$t_{LPH}$	Input clock pulse high time		1		ns
$t_{LAT}$	Clock latency (WRTA/B to outputs)	4		4	clk
$t_{PD}$	Propagation delay time		1.5		ns
<b>TIMING - SINGLE BUS INTERLEAVED MODE</b>					
$t_{su}$	Input setup time		0.5		ns
$t_h$	Input hold time		0.5		ns
$t_{LAT}$	Clock latency (WRTA/B to outputs)	4		4	clk
$t_{PD}$	Propagation delay time		1.5		ns

## 6.10 Typical Characteristics

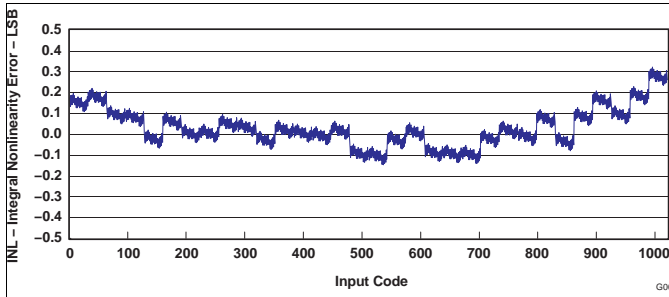

Figure 1. Integral Nonlinearity vs Input Code

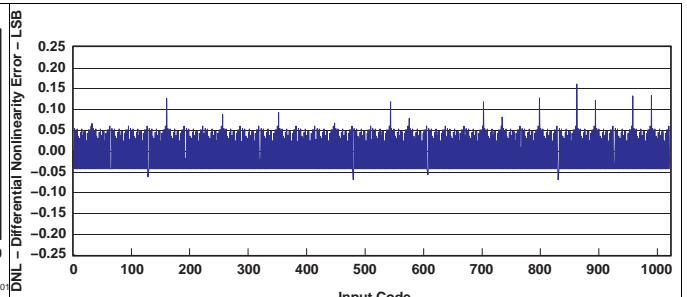

Figure 2. Differential Nonlinearity vs Input Code

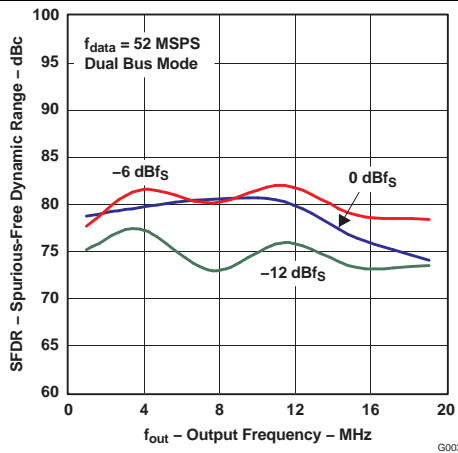

Figure 3. Spurious-Free Dynamic Range vs Output Frequency

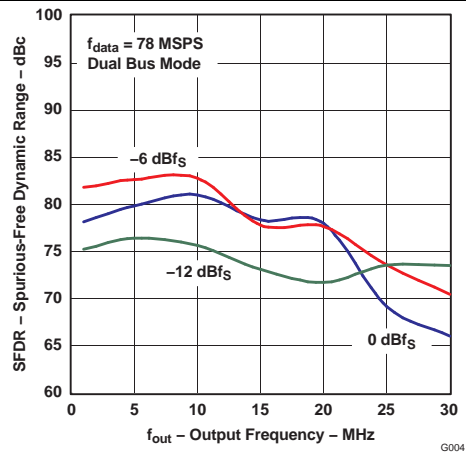

Figure 4. Spurious-Free Dynamic Range vs Output Frequency

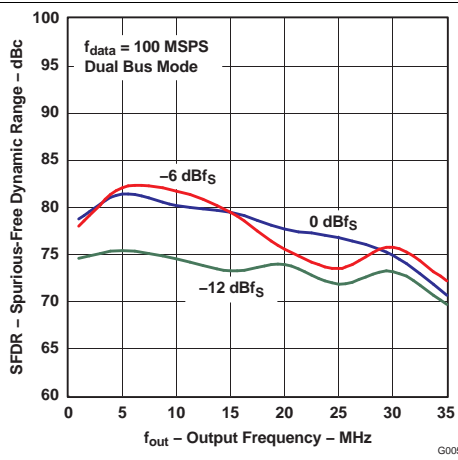

Figure 5. Spurious-Free Dynamic Range vs Output Frequency

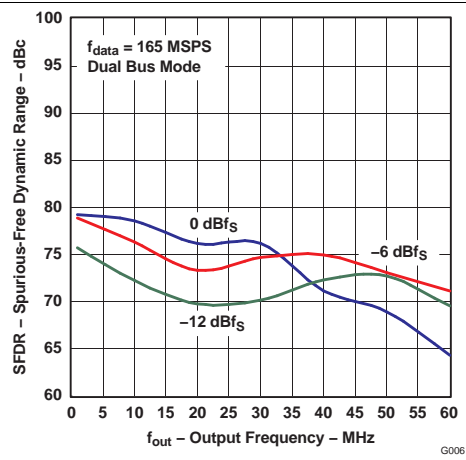

Figure 6. Spurious-Free Dynamic Range vs Output Frequency

Typical Characteristics (continued)

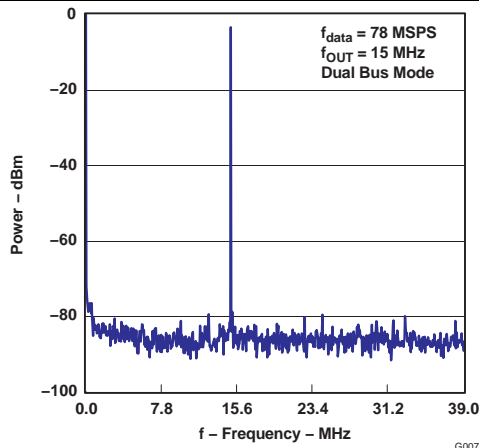

Figure 7. Single-Tone Spectrum

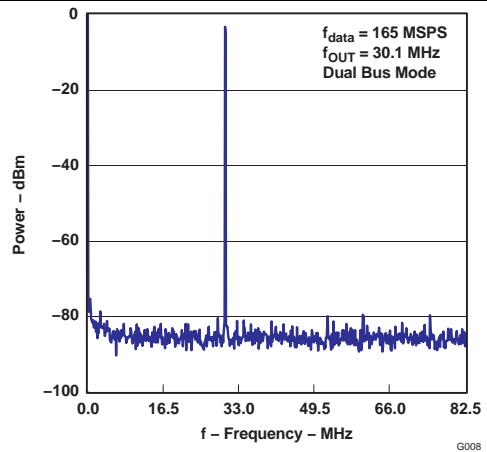

Figure 8. Single-Tone Spectrum

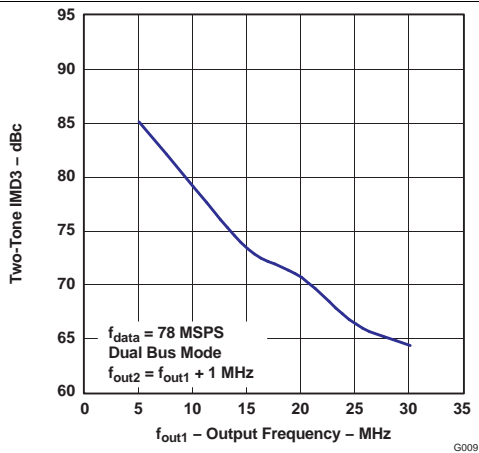

Figure 9. Two-Tone IMD3 vs Output Frequency

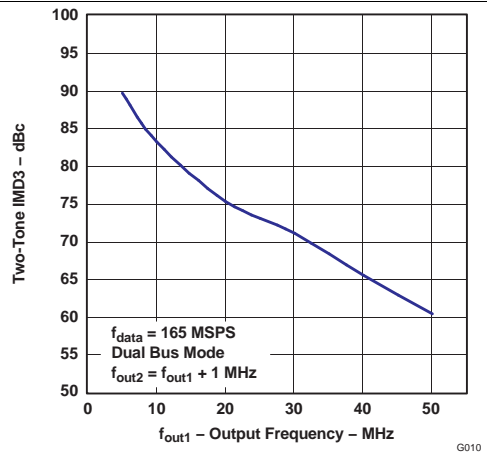

Figure 10. Two-Tone IMD3 vs Output Frequency

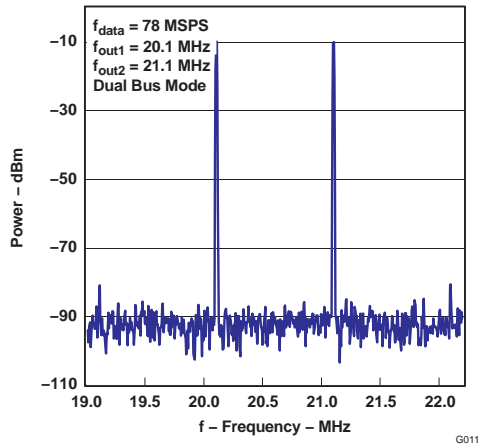

Figure 11. Two-Tone Spectrum

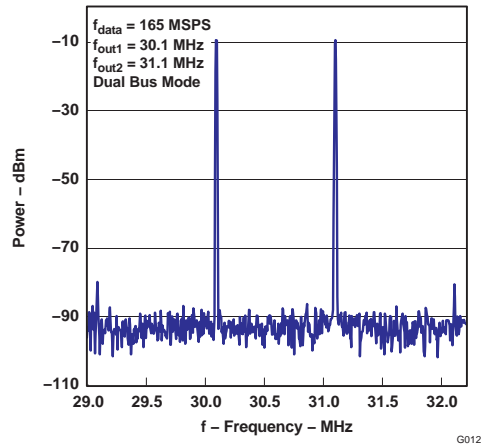

Figure 12. Two-Tone Spectrum

## 7 Detailed Description

### 7.1 Overview

The architecture of the DAC5652A uses a current steering technique to enable fast switching and a high update rate. The core element within the monolithic DAC is an array of segmented current sources that are designed to deliver a full-scale output current of up to 20 mA. An internal decoder addresses the differential current switches each time the DAC is updated, and a corresponding output current is formed by steering all currents to either output summing node, IOUT1 or IOUT2. The complementary outputs deliver a differential output signal, which improves the dynamic performance through reduction of even-order harmonics, common-mode signals (noise), and doubles the peak-to-peak output signal swing by a factor of two, as compared to single-ended operation.

The segmented architecture results in a significant reduction of the glitch energy and improves the dynamic performance (SFDR) and DNL. The current outputs maintain a very high output impedance of greater than 300 k $\Omega$ .

When pin 42 (GSET) is high (simultaneous gain set mode), the full-scale output current for DACs is determined by the ratio of the internal reference voltage (1.2 V) and an external resistor ( $R_{SET}$ ) connected to BIASJ\_A. When GSET is low (independent gain set mode), the full-scale output current for each DAC is determined by the ratio of the internal reference voltage (1.2 V) and separate external resistors ( $R_{SET}$ ) connected to BIASJ\_A and BIASJ\_B. The resulting  $I_{REF}$  is internally multiplied by a factor of 32 to produce an effective DAC output current that can range from 2 mA to 20 mA, depending on the value of  $R_{SET}$ .

The DAC5652A is split into a digital and an analog portion, each of which is powered through its own supply pin. The digital section includes edge-triggered input latches and the decoder logic, while the analog section comprises both the current source array with its associated switches, and the reference circuitry.

### 7.2 Functional Block Diagram

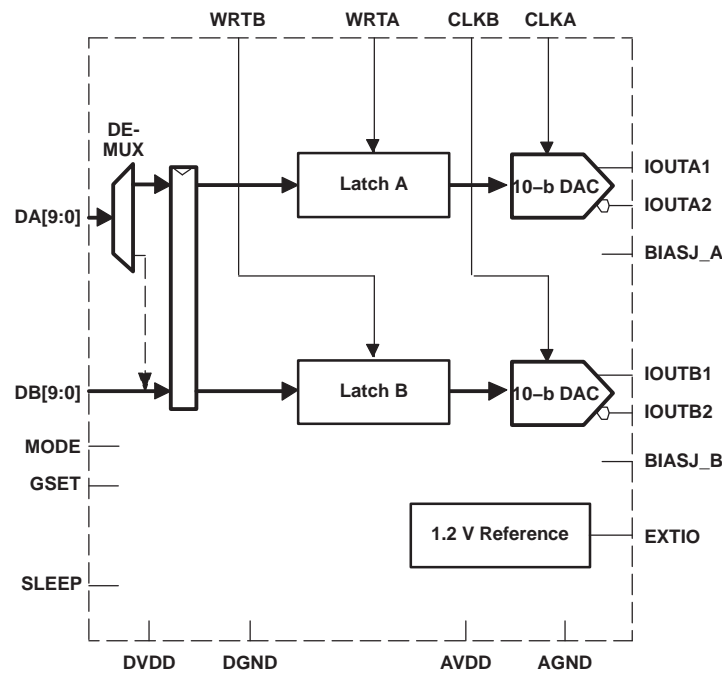

### 7.3 Feature Description

#### 7.3.1 Digital Inputs

The data input ports of the DAC5652A accept a standard positive coding with data bits DA9 and DB9 being the most significant bits (MSB). The converter outputs support a clock rate of up to 275 MSPS. The best performance is typically achieved with a symmetric duty cycle for write and clock; however, the duty cycle may vary as long as the timing specifications are met. Similarly, the setup and hold times may be chosen within their specified limits.

All digital inputs of the DAC5652A are CMOS compatible. Figure 13 and Figure 14 show schematics of the equivalent CMOS digital inputs of the DAC5652A. The pullup and pulldown circuitry is approximately equivalent to 100 kΩ. The 10-bit digital data input follows the offset positive binary coding scheme. The DAC5652A is designed to operate with a digital supply (DVDD) of 3 V to 3.6 V.

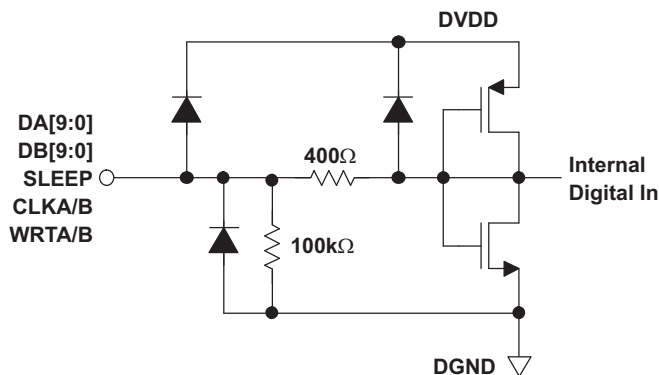

Figure 13. CMOS/TTL Digital Equivalent Input With Internal Pulldown Resistor

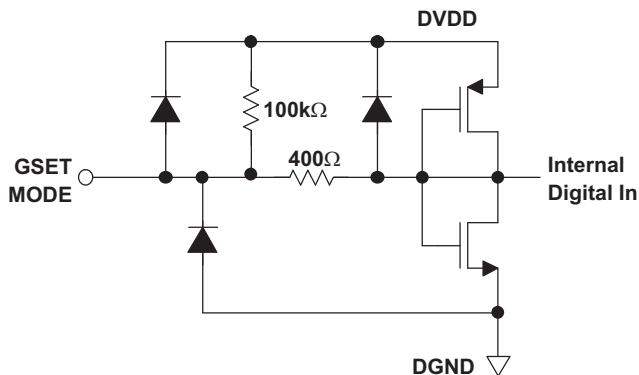

Figure 14. CMOS/TTL Digital Equivalent Input With Internal Pullup Resistor

## Feature Description (continued)

### 7.3.2 References

#### 7.3.2.1 Internal Reference

The DAC5652A has an on-chip reference circuit which comprises a 1.2-V bandgap reference and two control amplifiers, one for each DAC. The full-scale output current,  $I_{(OUTFS)}$ , of the DAC5652A is determined by the reference voltage,  $V_{REF}$ , and the value of resistor  $R_{SET}$ .  $I_{(OUTFS)}$  is calculated by:

$$I_{OUTFS} = 32 \times I_{REF} = 32 \times \frac{V_{REF}}{R_{SET}} \quad (1)$$

The reference control amplifier operates as a V-to-I converter producing a reference current,  $I_{REF}$ , which is determined by the ratio of  $V_{REF}$  and  $R_{SET}$  (see Equation 9). The full-scale output current,  $I_{(OUTFS)}$ , results from multiplying  $I_{REF}$  by a fixed factor of 32.

Using the internal reference, a 2-k $\Omega$  resistor value results in a full-scale output of approximately 20 mA. Resistors with a tolerance of 1% or better should be considered. Selecting higher values, the output current can be adjusted from 20 mA down to 2 mA. Operating the DAC5652A at lower than 20-mA output currents may be desirable for reasons of reducing the total power consumption, improving the distortion performance, or observing the output compliance voltage limitations for a given load condition.

It is recommended to bypass the EXTIO pin with a ceramic chip capacitor of 0.1  $\mu$ F or more. The control amplifier is internally compensated and its small signal bandwidth is approximately 300 kHz.

#### 7.3.2.2 External Reference

The internal reference can be disabled by simply applying an external reference voltage into the EXTIO pin, which in this case functions as an input. The use of an external reference may be considered for applications that require higher accuracy and drift performance or to add the ability of dynamic gain control.

While a 0.1- $\mu$ F capacitor is recommended to be used with the internal reference, it is optional for the external reference operation. The reference input, EXTIO, has a high input impedance (1 M $\Omega$ ) and can be driven by various sources. Note that the voltage range of the external reference must stay within the compliance range of the reference input.

## 7.4 Device Functional Modes

### 7.4.1 Input Interfaces

The DAC5652A features two operating modes selected by the MODE pin, as shown in Table 1.

- For dual-bus input mode, the device essentially consists of two separate DACs. Each DAC has its own separate data input bus, clock input, and data write signal (data latch-in).
- In single-bus interleaved mode, the data must be presented interleaved at the A-channel input bus. The B-channel input bus is not used in this mode. The clock and write input are now shared by both DACs.

Table 1. Operating Modes

MODE PIN	MODE PIN CONNECTED TO DGND	MODE PIN CONNECTED TO DVDD
Bus input	Single-bus interleaved mode, clock and write input equal for both DACs	Dual-bus mode, DACs operate independently

#### 7.4.1.1 Dual-Bus Data Interface and Timing

In dual-bus mode, the MODE pin is connected to DVDD. The two converter channels within the DAC5652A consist of two independent, 10-bit, parallel data ports. Each DAC channel is controlled by its own set of write (WRTA, WRTB) and clock (CLKA, CLKB) lines. The WRTA/B lines control the channel input latches and the CLKA/B lines control the DAC latches. The data is first loaded into the input latch by a rising edge of the WRTA/B line.

The internal data transfer requires a correct sequence of write and clock inputs, since essentially two clock domains having equal periods (but possibly different phases) are input to the DAC5652A. This is defined by a minimum requirement of the time between the rising edge of the clock and the rising edge of the write inputs. This essentially implies that the rising edge of CLKA/B must occur at the same time or before the rising edge of the WRTA/B signal. A minimum delay of 2 ns must be maintained if the rising edge of the clock occurs after the rising edge of the write. Note that these conditions are satisfied when the clock and write inputs are connected externally. Note that all specifications were measured with the WRTA/B and CLKA/B lines connected together.

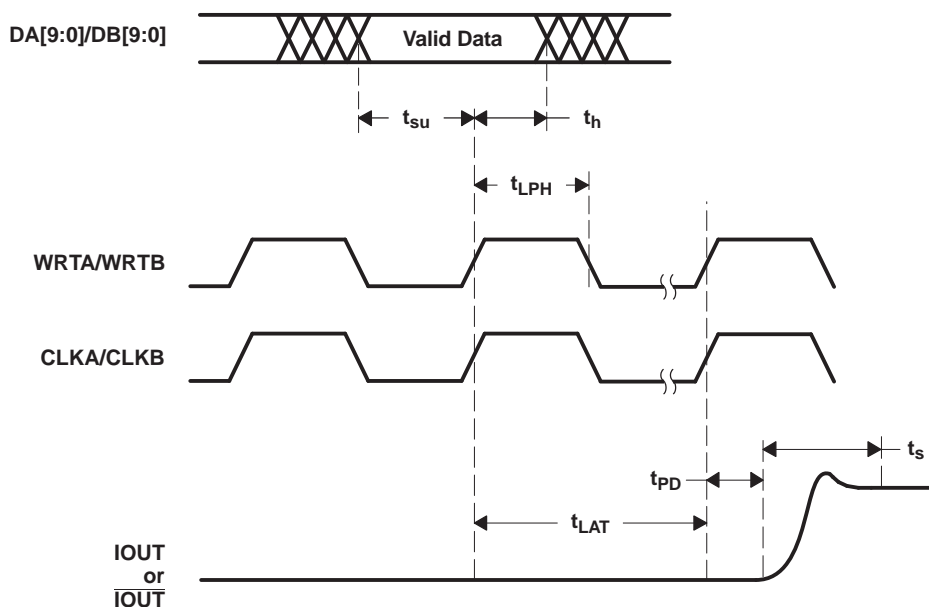

Figure 15. Dual-Bus Mode Operation

### 7.4.1.2 Single-Bus Interleaved Data Interface and Timing

In single-bus interleaved mode, the MODE pin is connected to DGND. Figure 16 shows the timing diagram. In interleaved mode, the A- and B-channels share the write input (WRTIQ) and update clock (CLKIQ and internal CLKDACIQ). Multiplexing logic directs the input word at the A-channel input bus to either the A-channel input latch (SELECTIQ is high) or to the B-channel input latch (SELECTIQ is low). When SELECTIQ is high, the data value in the B-channel latch is retained by presenting the latch output data to its input again. When SELECTIQ is low, the data value in the A-channel latch is retained by presenting the latch output data to its input.

In interleaved mode, the A-channel input data rate is twice the update rate of the DAC core. As in dual-bus mode, it is important to maintain a correct sequence of write and clock inputs. The edge-triggered flip-flops latch the A- and B-channel input words on the rising edge of the write input (WRTIQ). This data is presented to the A- and B-DAC latches on the following falling edge of the write inputs. The DAC5652A clock input is divided by a factor of two before it is presented to the DAC latches.

Correct pairing of the A- and B-channel data is done by RESETIQ. In interleaved mode, the clock input CLKIQ is divided by two, which would translate to a non-deterministic relation between the rising edges of the CLKIQ and CLKDACIQ. RESETIQ ensures, however, that the correct position of the rising edge of CLKDACIQ with respect to the data at the input of the DAC latch is determined. CLKDACIQ is disabled (low) when RESETIQ is high.

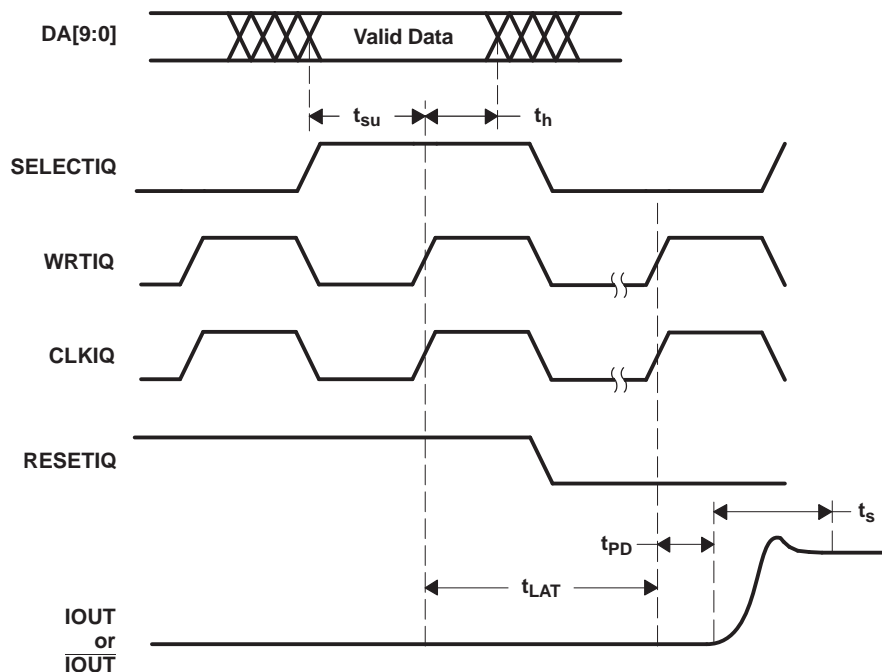

**Figure 16. Single-Bus Interleaved Mode Operation**

### 7.4.2 Gain Setting Option

The full-scale output current on the DAC5652A can be set two ways: either for each of the two DAC channels independently or for both channels simultaneously. For the independent gain set mode, the GSET pin (pin 42) must be low (that is, connected to AGND). In this mode, two external resistors are required — one  $R_{SET}$  connected to the BIASJ\_A pin (pin 44) and the other to the BIASJ\_B pin (pin 41). In this configuration, the user has the flexibility to set and adjust the full-scale output current for each DAC independently, allowing for the compensation of possible gain mismatches elsewhere within the transmit signal path.

Alternatively, bringing the GSET pin high (that is, connected to AVDD), the DAC5652A switches into the simultaneous gain set mode. Now the full-scale output current of both DAC channels is determined by only one external  $R_{SET}$  resistor connected to the BIASJ\_A pin. The resistor at the BIASJ\_B pin may be removed; however, this is not required since this pin is not functional in this mode and the resistor has no effect on the gain equation.

### 7.4.3 Sleep Mode

The DAC5652A features a power-down function that can reduce the total supply current to approximately 3.1 mA over the specified supply range if no clock is present. Applying a logic high to the SLEEP pin initiates power-down mode, whereas a logic low enables normal operation. When left unconnected, an internal active pulldown circuit enables the normal operation of the converter.

## 8 Application and Implementation

### NOTE

Information in the following applications sections is not part of the TI component specification, and TI does not warrant its accuracy or completeness. TI's customers are responsible for determining suitability of components for their purposes. Customers should validate and test their design implementation to confirm system functionality.

### 8.1 Application Information

The DAC5652A is a 10-bit dual DAC with max update rate of 275 MSPS. The DAC supports two different modes of operation: dual bus and single bus. In dual-bus mode, the DAC provides two independent transmit paths that can be programmed for two different update rates. In single-bus mode, the interleaved data for both channels are applied at the A-channel input bus. The B-channel input bus is not used in this mode. The clock and write input are now shared by both DACs. Thus, two different input signals can be transmitted from the two channels, but the update rate for both channels is the same.

#### 8.1.1 DAC Transfer Function

Each of the DACs in the DAC5652A has a set of complementary current outputs, I<sub>OUT1</sub> and I<sub>OUT2</sub>. The full-scale output current, I<sub>OUTFS</sub>, is the summation of the two complementary output currents:

$$I_{OUTFS} = I_{OUT1} + I_{OUT2} \quad (2)$$

The individual output currents depend on the DAC code and can be expressed as:

$$I_{OUT1} = I_{OUTFS} \times \left( \frac{\text{Code}}{1024} \right) \quad (3)$$

$$I_{OUT2} = I_{OUTFS} \times \left( \frac{1023 - \text{Code}}{1024} \right) \quad (4)$$

where Code is the decimal representation of the DAC data input word. Additionally, I<sub>OUTFS</sub> is a function of the reference current I<sub>REF</sub>, which is determined by the reference voltage and the external setting resistor (R<sub>SET</sub>).

$$I_{OUTFS} = 32 \times I_{REF} = 32 \times \frac{V_{REF}}{R_{SET}} \quad (5)$$

In most cases, the complementary outputs drive resistive loads or a terminated transformer. A signal voltage develops at each output according to:

$$V_{OUT1} = I_{OUT1} \times R_{LOAD} \quad (6)$$

$$V_{OUT2} = I_{OUT2} \times R_{LOAD} \quad (7)$$

The value of the load resistance is limited by the output compliance specification of the DAC5652A. To maintain specified linearity performance, the voltage for I<sub>OUT1</sub> and I<sub>OUT2</sub> must not exceed the maximum allowable compliance range.

The total differential output voltage is:

$$V_{OUTDIFF} = V_{OUT1} - V_{OUT2} \quad (8)$$

$$V_{OUTDIFF} = \frac{(2 \times \text{Code} - 1023)}{1024} \times I_{OUTFS} \times R_{LOAD} \quad (9)$$

## Application Information (continued)

### 8.1.1.1 Analog Outputs

The DAC5652A provides two complementary current outputs, IOUT1 and IOUT2. The simplified circuit of the analog output stage representing the differential topology is shown in Figure 17. The output impedance of IOUT1 and IOUT2 results from the parallel combination of the differential switches, along with the current sources and associated parasitic capacitances.

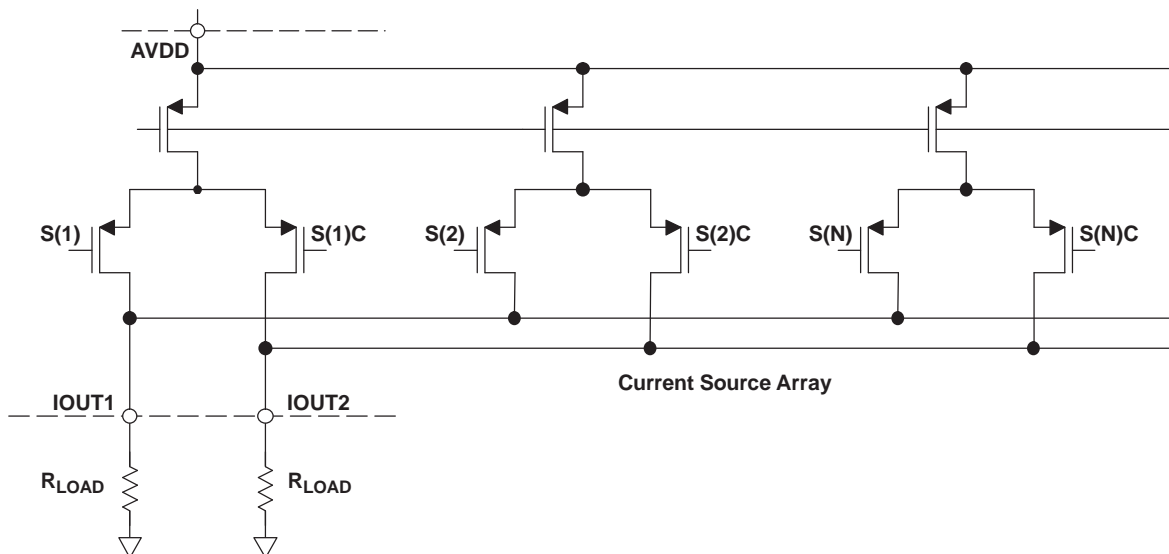

Figure 17. Analog Outputs

The signal voltage swing that may develop at the two outputs, IOUT1 and IOUT2, is limited by a negative and positive compliance. The negative limit of  $-1$  V is given by the breakdown voltage of the CMOS process and exceeding it compromises the reliability of the DAC5652A (or even causes permanent damage). With the full-scale output set to 20 mA, the positive compliance equals 1.2 V. Note that the compliance range decreases to about 1 V for a selected output current of  $I_{(OUTFS)} = 2$  mA. Care must be taken that the configuration of DAC5652A does not exceed the compliance range to avoid degradation of the distortion performance and integral linearity.

Best distortion performance is typically achieved with the maximum full-scale output signal limited to approximately  $0.5 V_{PP}$ . This is the case for a  $50\text{-}\Omega$  doubly-terminated load and a 20-mA full-scale output current. A variety of loads can be adapted to the output of the DAC5652A by selecting a suitable transformer while maintaining optimum voltage levels at IOUT1 and IOUT2. Furthermore, using the differential output configuration in combination with a transformer is instrumental for achieving excellent distortion performance. Common-mode errors, such as even-order harmonics or noise, can be substantially reduced. This is particularly the case with high output frequencies.

For those applications requiring the optimum distortion and noise performance, it is recommended to select a full-scale output of 20 mA. A lower full-scale range of 2 mA may be considered for applications that require low power consumption, but can tolerate a slight reduction in performance level.

### 8.1.2 Output Configurations

The current outputs of the DAC5652A allow for a variety of configurations. As mentioned previously, utilizing the converter's differential outputs yield the best dynamic performance. Such a differential output circuit may consist of an RF transformer or a differential amplifier configuration. The transformer configuration is ideal for most applications with ac coupling, while op amps are suitable for a dc-coupled configuration.

The single-ended configuration may be considered for applications requiring a unipolar output voltage. Connecting a resistor from either one of the outputs to ground converts the output current into a ground-referenced voltage signal. To improve on the dc linearity by maintaining a virtual ground, an I-to-V or op-amp configuration may be considered.

## Application Information (continued)

### 8.1.3 Differential With Transformer

Using an RF transformer provides a convenient way of converting the differential output signal into a single-ended signal while achieving excellent dynamic performance. The appropriate transformer must be carefully selected based on the output frequency spectrum and impedance requirements.

The differential transformer configuration has the benefit of significantly reducing common-mode signals, thus improving the dynamic performance over a wide range of frequencies. Furthermore, by selecting a suitable impedance ratio (winding ratio) the transformer can provide optimum impedance matching while controlling the compliance voltage for the converter outputs.

Figure 18 and Figure 19 show 50-Ω doubly-terminated transformer configurations with 1:1 and 4:1 impedance ratios, respectively. Note that the center tap of the primary input of the transformer has to be grounded to enable a dc-current flow. Applying a 20-mA full-scale output current would lead to a 0.5-V<sub>PP</sub> output for a 1:1 transformer and a 1-V<sub>PP</sub> output for a 4:1 transformer. In general, the 1:1 transformer configuration has a better output distortion, but the 4:1 transformer has 6 dB higher output power.

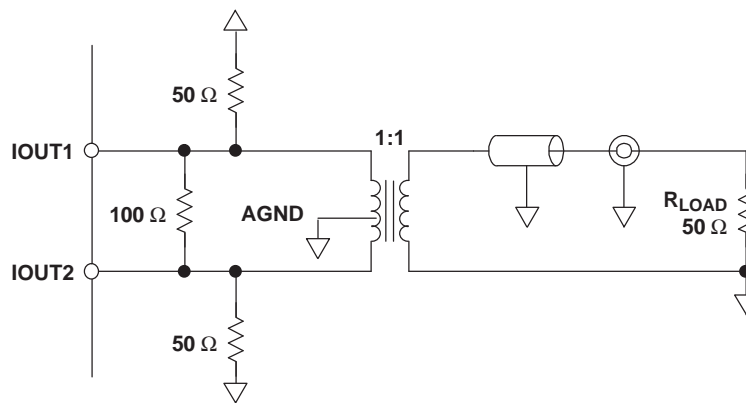

**Figure 18. Driving a Doubly-Terminated 50-Ω Cable Using a 1:1 Impedance Ratio Transformer**

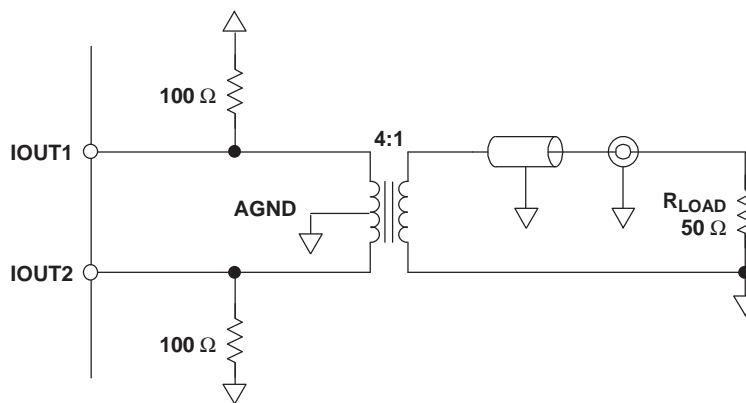

**Figure 19. Driving a Doubly-Terminated 50-Ω Cable Using a 4:1 Impedance Ratio Transformer**

## Application Information (continued)

### 8.1.4 Single-Ended Configuration

Figure 20 shows the single-ended output configuration, where the output current IOUT1 flows into an equivalent load resistance of 25  $\Omega$ . Node IOUT2 must be connected to AGND or terminated with a resistor of 25  $\Omega$  to AGND. The nominal resistor load of 25  $\Omega$  gives a differential output swing of 1 V<sub>PP</sub> when applying a 20-mA full-scale output current.

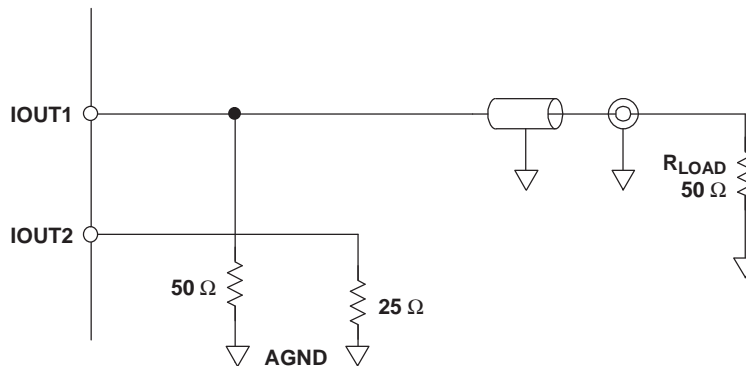

Figure 20. Driving a Doubly-Terminated 50- $\Omega$  Cable Using a Single-Ended Output

## 8.2 Typical Application

A typical application for the DAC5652A is a dual- or single-carrier transmitter. The DAC is provided with some input digital baseband signal, and outputs an analog carrier. A design example for a single-carrier transmitter is described in this section.

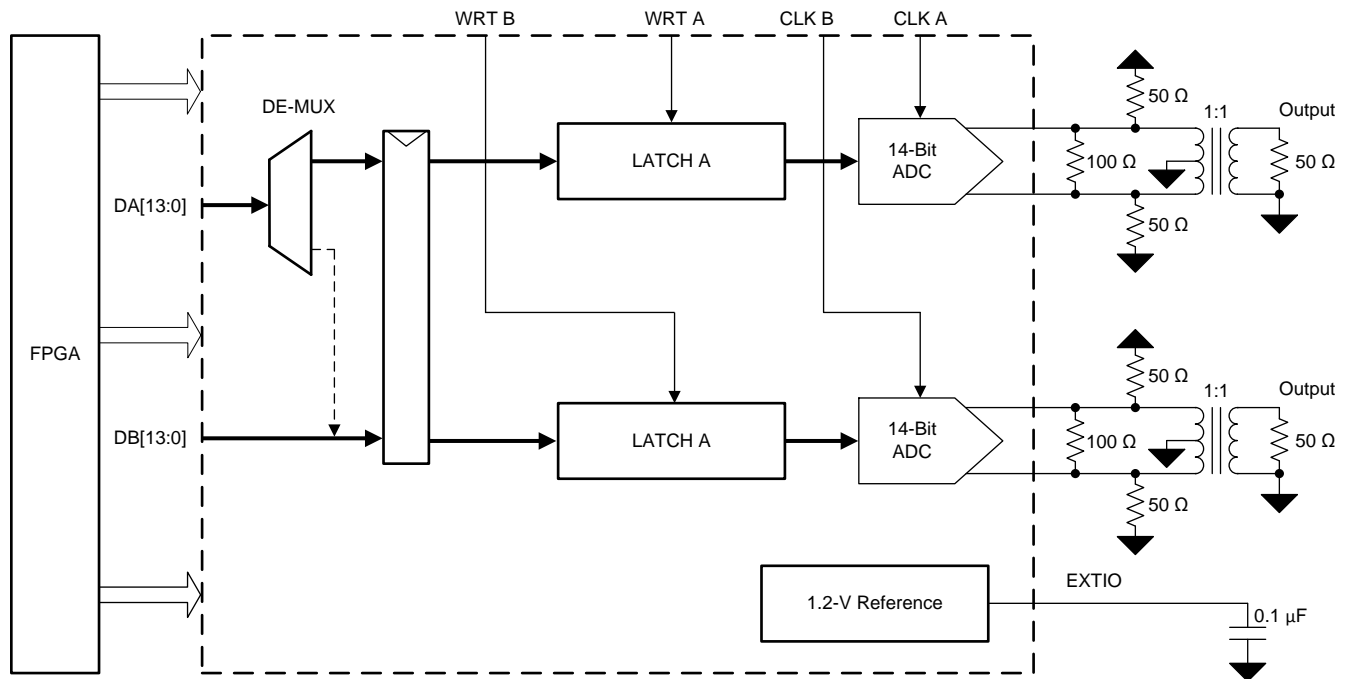

Figure 21. Single-Carrier Transmitter

### 8.2.1 Design Requirements

The requirements for this design are to generate a single WCDMA signal at an intermediate frequency of 30.72 MHz. The ACLR needs to be better than 72 dBc.

Table 2. Design Parameters

FEATURE	SPECIFICATION
Number of carriers	1
AVDD and DVDD	3.3 V
Clock rate	122.88 MSPS
Input data	WCDMA with IF at 30.72 MHz
ACPR	> 72 dB

### 8.2.2 Detailed Design Procedure

The single WCDMA carrier signal with an intermediate frequency (IF) of 30.72 MHz must be created in the digital processor at a sample rate of 122.88 MSPS for the DAC. These 10-bit samples are placed on the 10-bit CMOS input port of the DAC.

A CMOS DAC clock must be generated from a clock source at 122.88 MHz. This clock must be provided to the CLK pin of the DAC. The IOUTA and IOUTB differential connections must be connected to a transformer in order to provide a single-ended output. A typical 1:1 impedance transformer is used on the device EVM. The DAC5672A evaluation module (EVM) provides a good reference for this design example.

### 8.2.3 Application Curve

Figure 22 presents a spectrum analyzer plot shows the adjacent channel power ratio (ACPR) for the transformer-output, single-carrier signal with an intermediate frequency of 30.72 MHz. The results meet the system requirements for a minimum of 72-dBc ACPR.

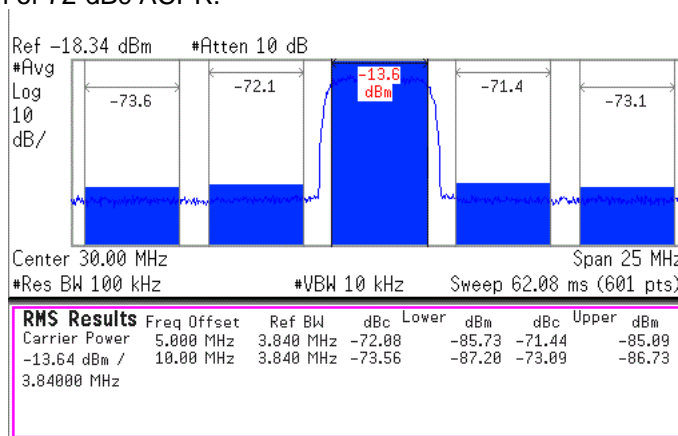

Figure 22. ACPR Performance

## 9 Power Supply Recommendations

Power the device with the nominal supply voltages as indicated in the *Recommended Operating Conditions*.

In most instances, the best performance is achieved with LDO supplies. However, the supplies may be driven with direct outputs from a DC/DC switcher, as long as the noise performance of the switcher is acceptable.

For best performance:

- Use at least two power layers.
- Avoid placing digital supplies and clean supplies on adjacent board layers.
- Use a ground layer between noisy and clean supplies, if possible.
- Decouple all supply pins as close to the pins as possible, using small-value capacitors, with larger, bulk capacitors placed further away.

## 10 Layout

### 10.1 Layout Guidelines

Use the DAC5652AEVM layout as a reference to obtain the best performance. A sample layout is shown in Figure 23 through Figure 26. Some important layout recommendations are:

1. Use a single ground plane. Keep the digital and analog signals on distinct separate sections of the board. This may be virtually divided down the middle of the device package when doing placement and layout.
2. Keep the analog outputs as far away from the switching clocks and digital signals as possible. This keeps coupling from the digital circuits to the analog outputs to a minimum.
3. Keep decoupling capacitors close to the power pins of the device.

## 10.2 Layout Examples

Figure 23 through Figure 26 show the layout examples.

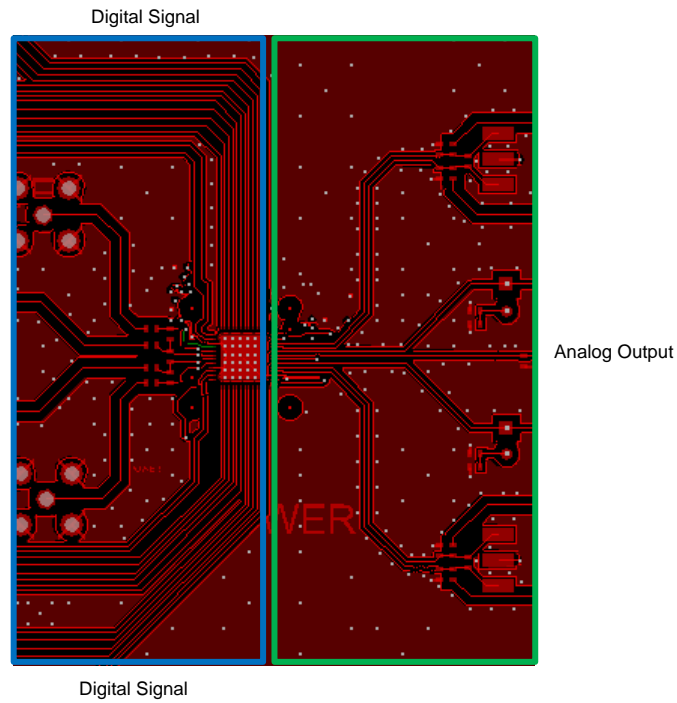

Figure 23. Layout Example: Top Layer (Layer 1)

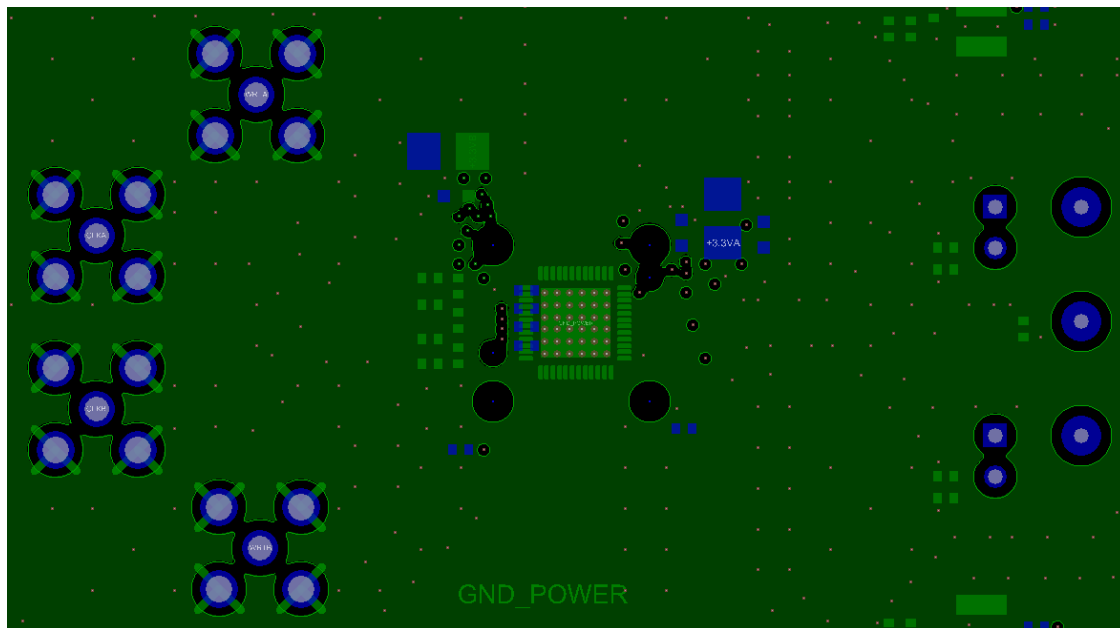
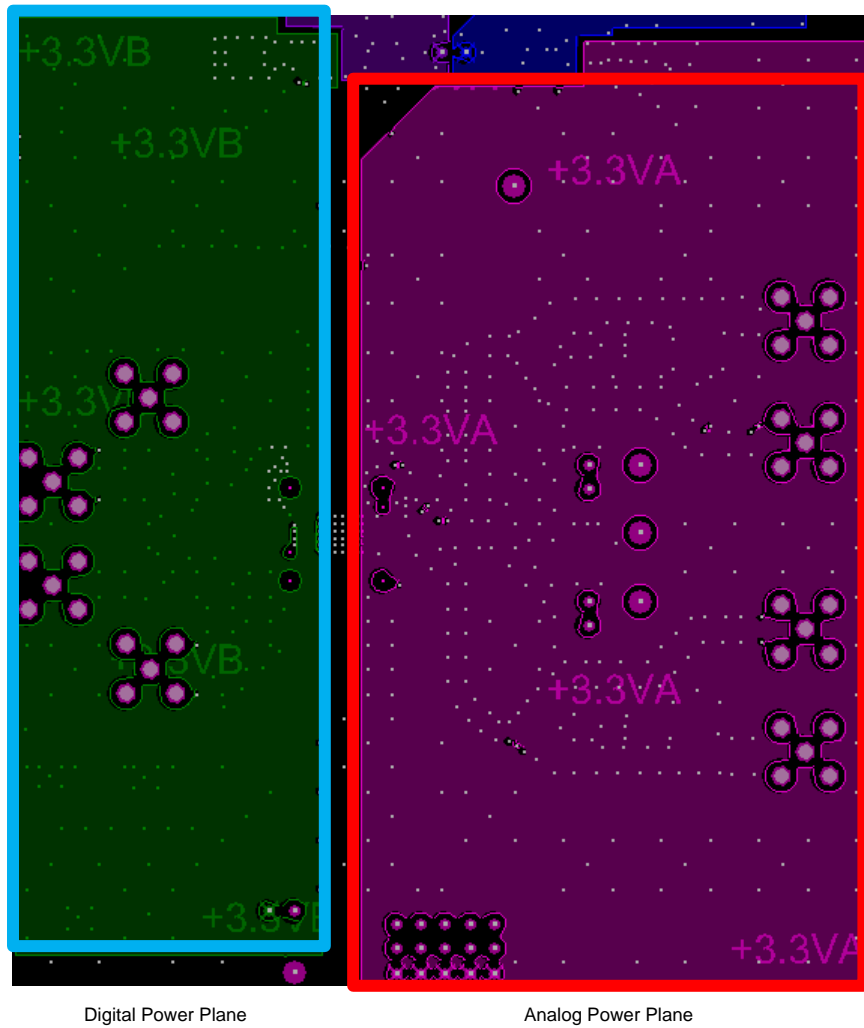

Figure 24. Layout Example: Single Ground Plane (Layer 2)

Layout Examples (continued)



Digital Power Plane

Analog Power Plane

Figure 25. Layout Example: Power Plane (Layer 3)

Layout Examples (continued)

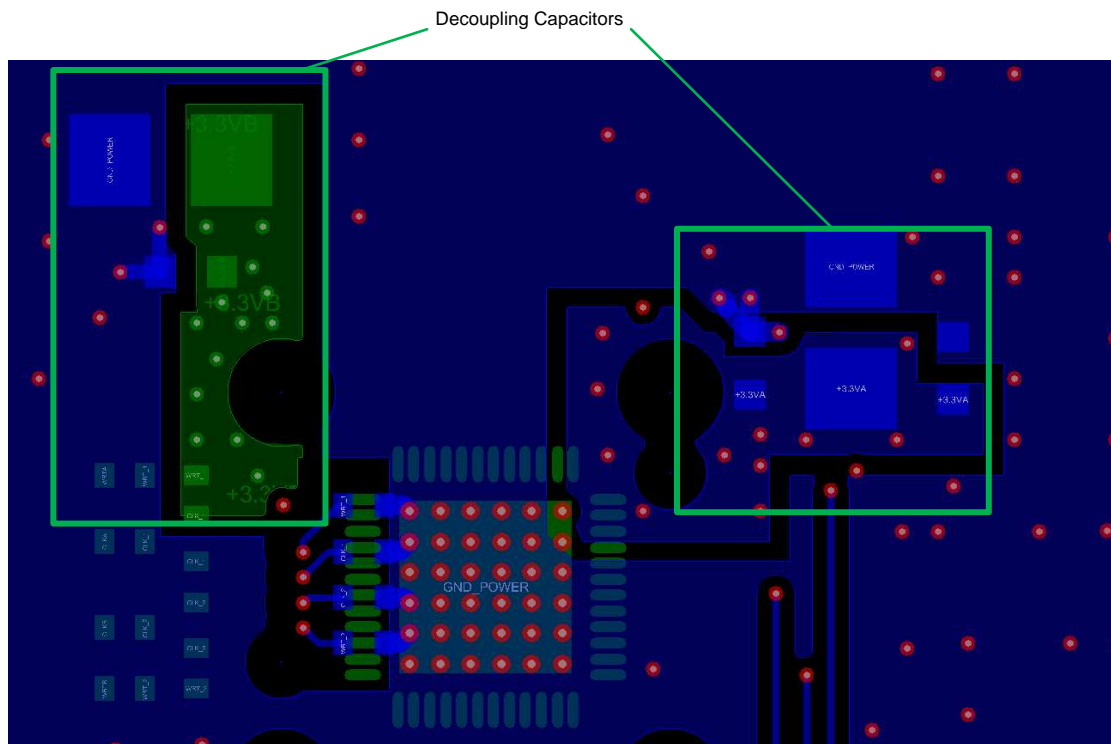

Figure 26. Layout Example: Bottom Layer (Layer 4)

## 11 Device and Documentation Support

### 11.1 Documentation Support

#### 11.1.1 Related Documentation

For related documentation see the following:

[DAC5652AEVM User's Guide](#)

### 11.2 Receiving Notification of Documentation Updates

To receive notification of documentation updates, navigate to the device product folder on [ti.com](http://ti.com). In the upper right corner, click on *Alert me* to register and receive a weekly digest of any product information that has changed. For change details, review the revision history included in any revised document.

### 11.3 Community Resources

The following links connect to TI community resources. Linked contents are provided "AS IS" by the respective contributors. They do not constitute TI specifications and do not necessarily reflect TI's views; see TI's [Terms of Use](#).

**TI E2E™ Online Community** *TI's Engineer-to-Engineer (E2E) Community*. Created to foster collaboration among engineers. At [e2e.ti.com](http://e2e.ti.com), you can ask questions, share knowledge, explore ideas and help solve problems with fellow engineers.

**Design Support** *TI's Design Support* Quickly find helpful E2E forums along with design support tools and contact information for technical support.

### 11.4 Trademarks

E2E is a trademark of Texas Instruments.  
All other trademarks are the property of their respective owners.

### 11.5 Electrostatic Discharge Caution



This integrated circuit can be damaged by ESD. Texas Instruments recommends that all integrated circuits be handled with appropriate precautions. Failure to observe proper handling and installation procedures can cause damage.

ESD damage can range from subtle performance degradation to complete device failure. Precision integrated circuits may be more susceptible to damage because very small parametric changes could cause the device not to meet its published specifications.

### 11.6 Glossary

[SLYZ022](#) — *TI Glossary*.

This glossary lists and explains terms, acronyms, and definitions.

## 12 Mechanical, Packaging, and Orderable Information

The following pages include mechanical, packaging, and orderable information. This information is the most current data available for the designated devices. This data is subject to change without notice and revision of this document. For browser-based versions of this data sheet, refer to the left-hand navigation.

**PACKAGING INFORMATION**

Orderable Device	Status (1)	Package Type	Package Drawing	Pins	Package Qty	Eco Plan (2)	Lead/Ball Finish (6)	MSL Peak Temp (3)	Op Temp (°C)	Device Marking (4/5)	Samples
DAC5652AIPFB	ACTIVE	TQFP	PFB	48	250	Green (RoHS & no Sb/Br)	CU NIPDAU	Level-2-260C-1 YEAR	-40 to 85	DAC5652AI	<a href="#">Samples</a>
DAC5652AIPFBR	ACTIVE	TQFP	PFB	48	1000	Green (RoHS & no Sb/Br)	CU NIPDAU	Level-2-260C-1 YEAR	-40 to 85	DAC5652AI	<a href="#">Samples</a>
DAC5652AIRSLR	ACTIVE	VQFN	RSL	48	2500	Green (RoHS & no Sb/Br)	CU NIPDAU	Level-2-260C-1 YEAR	-40 to 85	DA5652A	<a href="#">Samples</a>
DAC5652AIRSLT	ACTIVE	VQFN	RSL	48	250	Green (RoHS & no Sb/Br)	CU NIPDAU	Level-2-260C-1 YEAR	-40 to 85	DA5652A	<a href="#">Samples</a>

(1) The marketing status values are defined as follows:

**ACTIVE:** Product device recommended for new designs.

**LIFEBUY:** TI has announced that the device will be discontinued, and a lifetime-buy period is in effect.

**NRND:** Not recommended for new designs. Device is in production to support existing customers, but TI does not recommend using this part in a new design.

**PREVIEW:** Device has been announced but is not in production. Samples may or may not be available.

**OBSOLETE:** TI has discontinued the production of the device.

(2) **RoHS:** TI defines "RoHS" to mean semiconductor products that are compliant with the current EU RoHS requirements for all 10 RoHS substances, including the requirement that RoHS substance do not exceed 0.1% by weight in homogeneous materials. Where designed to be soldered at high temperatures, "RoHS" products are suitable for use in specified lead-free processes. TI may reference these types of products as "Pb-Free".

**RoHS Exempt:** TI defines "RoHS Exempt" to mean products that contain lead but are compliant with EU RoHS pursuant to a specific EU RoHS exemption.

**Green:** TI defines "Green" to mean the content of Chlorine (Cl) and Bromine (Br) based flame retardants meet JS709B low halogen requirements of <=1000ppm threshold. Antimony trioxide based flame retardants must also meet the <=1000ppm threshold requirement.

(3) MSL, Peak Temp. - The Moisture Sensitivity Level rating according to the JEDEC industry standard classifications, and peak solder temperature.

(4) There may be additional marking, which relates to the logo, the lot trace code information, or the environmental category on the device.

(5) Multiple Device Markings will be inside parentheses. Only one Device Marking contained in parentheses and separated by a "-" will appear on a device. If a line is indented then it is a continuation of the previous line and the two combined represent the entire Device Marking for that device.

(6) Lead/Ball Finish - Orderable Devices may have multiple material finish options. Finish options are separated by a vertical ruled line. Lead/Ball Finish values may wrap to two lines if the finish value exceeds the maximum column width.

**Important Information and Disclaimer:** The information provided on this page represents TI's knowledge and belief as of the date that it is provided. TI bases its knowledge and belief on information provided by third parties, and makes no representation or warranty as to the accuracy of such information. Efforts are underway to better integrate information from third parties. TI has taken and

continues to take reasonable steps to provide representative and accurate information but may not have conducted destructive testing or chemical analysis on incoming materials and chemicals. TI and TI suppliers consider certain information to be proprietary, and thus CAS numbers and other limited information may not be available for release.

In no event shall TI's liability arising out of such information exceed the total purchase price of the TI part(s) at issue in this document sold by TI to Customer on an annual basis.

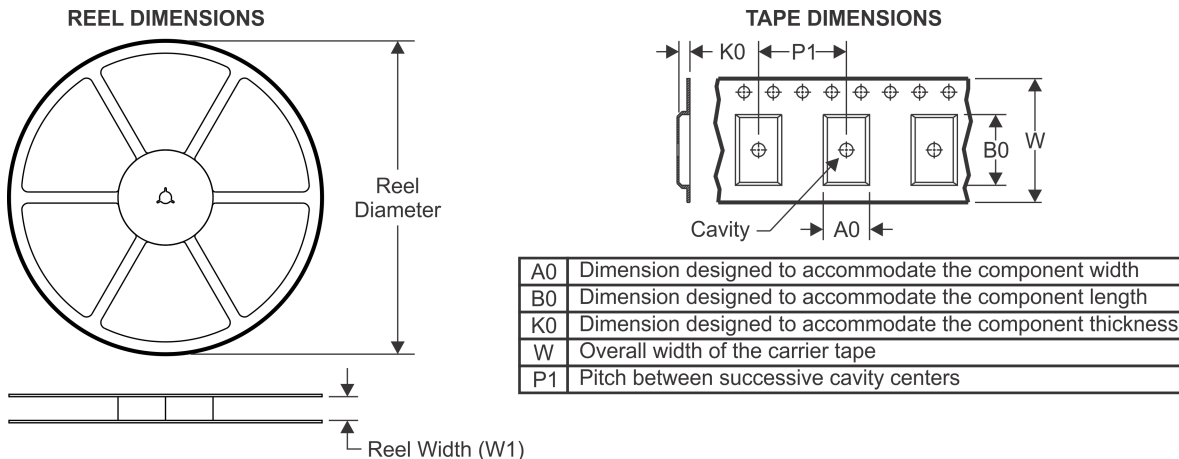
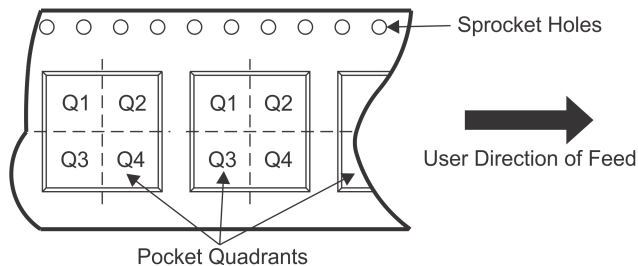
**TAPE AND REEL INFORMATION**

**QUADRANT ASSIGNMENTS FOR PIN 1 ORIENTATION IN TAPE**

\*All dimensions are nominal

Device	Package Type	Package Drawing	Pins	SPQ	Reel Diameter (mm)	Reel Width W1 (mm)	A0 (mm)	B0 (mm)	K0 (mm)	P1 (mm)	W (mm)	Pin1 Quadrant
DAC5652AIPFBR	TQFP	PFB	48	1000	330.0	16.4	9.6	9.6	1.5	12.0	16.0	Q2
DAC5652AIRSLR	VQFN	RSL	48	2500	330.0	16.4	6.3	6.3	1.1	12.0	16.0	Q2
DAC5652AIRSLT	VQFN	RSL	48	250	180.0	16.4	6.3	6.3	1.1	12.0	16.0	Q2

**TAPE AND REEL BOX DIMENSIONS**



\*All dimensions are nominal

Device	Package Type	Package Drawing	Pins	SPQ	Length (mm)	Width (mm)	Height (mm)
DAC5652AIPFBR	TQFP	PFB	48	1000	367.0	367.0	38.0
DAC5652AIRSLR	VQFN	RSL	48	2500	367.0	367.0	35.0
DAC5652AIRSLT	VQFN	RSL	48	250	210.0	185.0	35.0

# MECHANICAL DATA

RSL (S-PVQFN-N48)

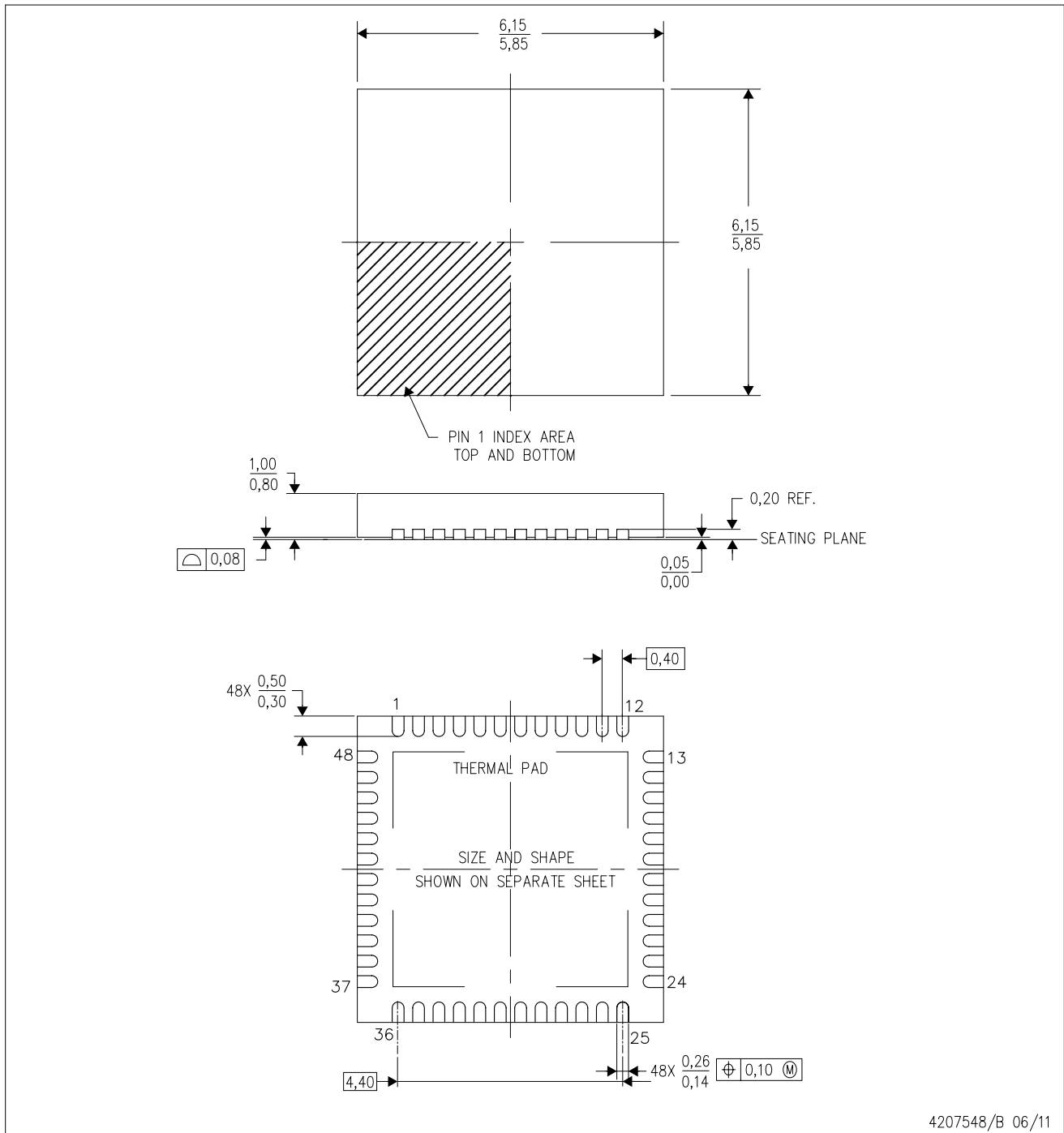
PLASTIC QUAD FLATPACK NO-LEAD



- NOTES:
- All linear dimensions are in millimeters. Dimensioning and tolerancing per ASME Y14.5M-1994.
  - This drawing is subject to change without notice.
  - Quad Flatpack, No-leads (QFN) package configuration.
  - The package thermal pad must be soldered to the board for thermal and mechanical performance.
  - See the additional figure in the Product Data Sheet for details regarding the exposed thermal pad features and dimensions.

PFB (S-PQFP-G48)

PLASTIC QUAD FLATPACK

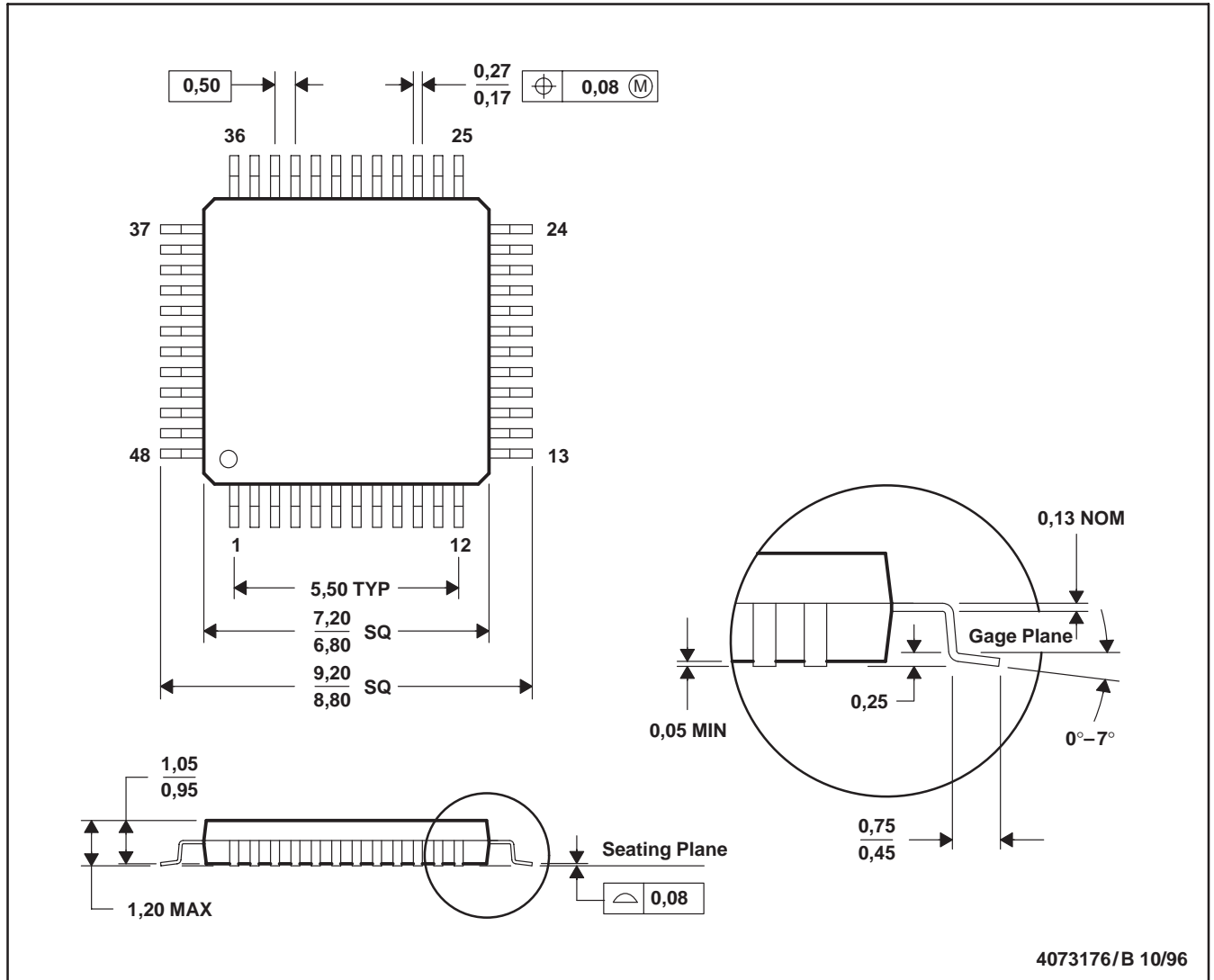

- NOTES: A. All linear dimensions are in millimeters.  
 B. This drawing is subject to change without notice.  
 C. Falls within JEDEC MS-026

PFB (S-PQFP-G48)

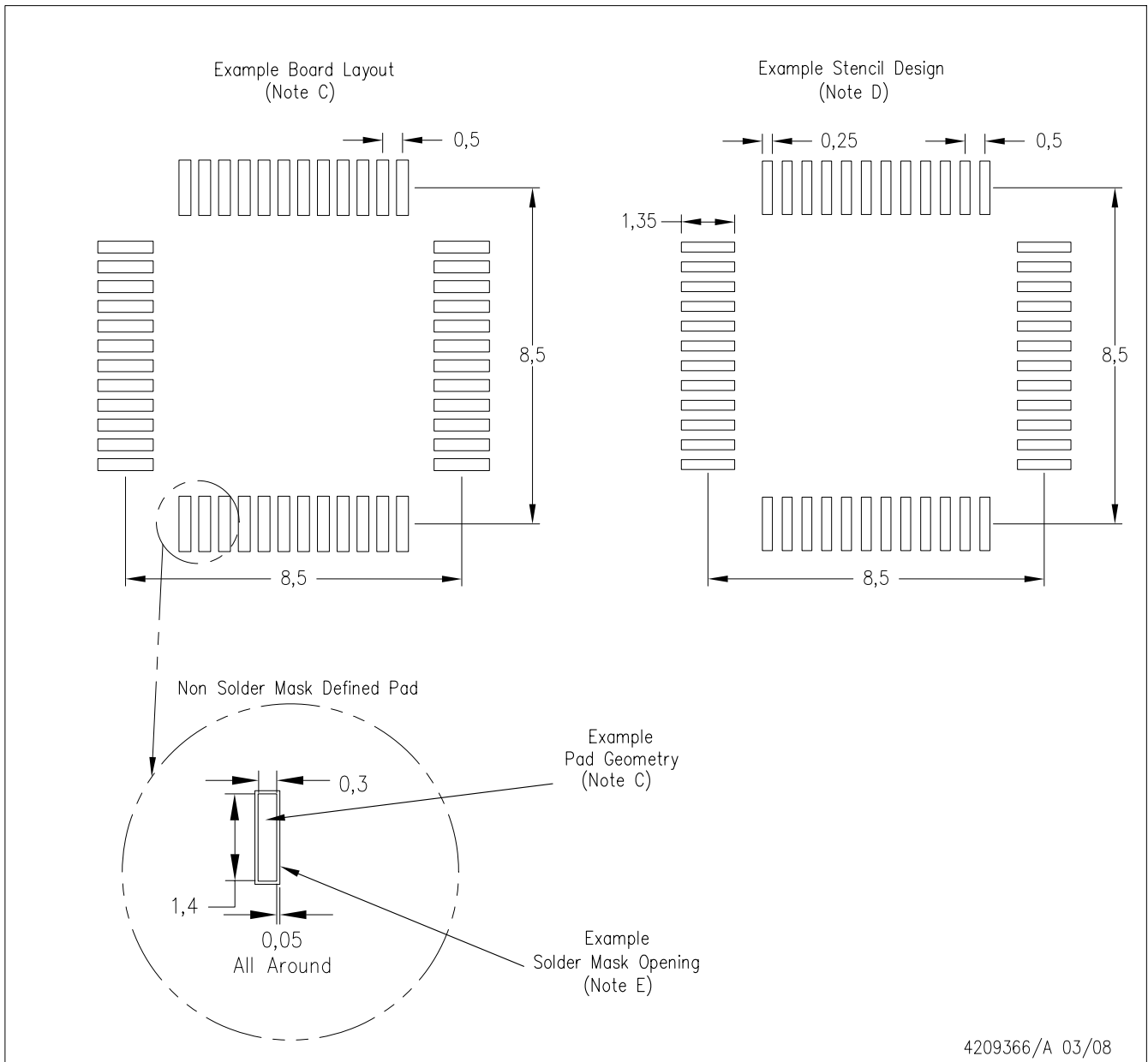

- NOTES:
- A. All linear dimensions are in millimeters.
  - B. This drawing is subject to change without notice.
  - C. Publication IPC-7351 is recommended for alternate designs.
  - D. Laser cutting apertures with trapezoidal walls and also rounding corners will offer better paste release. Customers should contact their board assembly site for stencil design recommendations. Refer to IPC-7525.
  - E. Customers should contact their board fabrication site for solder mask tolerances between and around signal pads.

## IMPORTANT NOTICE AND DISCLAIMER

TI PROVIDES TECHNICAL AND RELIABILITY DATA (INCLUDING DATASHEETS), DESIGN RESOURCES (INCLUDING REFERENCE DESIGNS), APPLICATION OR OTHER DESIGN ADVICE, WEB TOOLS, SAFETY INFORMATION, AND OTHER RESOURCES "AS IS" AND WITH ALL FAULTS, AND DISCLAIMS ALL WARRANTIES, EXPRESS AND IMPLIED, INCLUDING WITHOUT LIMITATION ANY IMPLIED WARRANTIES OF MERCHANTABILITY, FITNESS FOR A PARTICULAR PURPOSE OR NON-INFRINGEMENT OF THIRD PARTY INTELLECTUAL PROPERTY RIGHTS.

These resources are intended for skilled developers designing with TI products. You are solely responsible for (1) selecting the appropriate TI products for your application, (2) designing, validating and testing your application, and (3) ensuring your application meets applicable standards, and any other safety, security, or other requirements. These resources are subject to change without notice. TI grants you permission to use these resources only for development of an application that uses the TI products described in the resource. Other reproduction and display of these resources is prohibited. No license is granted to any other TI intellectual property right or to any third party intellectual property right. TI disclaims responsibility for, and you will fully indemnify TI and its representatives against, any claims, damages, costs, losses, and liabilities arising out of your use of these resources.

TI's products are provided subject to TI's Terms of Sale ([www.ti.com/legal/termsofsale.html](http://www.ti.com/legal/termsofsale.html)) or other applicable terms available either on [ti.com](http://ti.com) or provided in conjunction with such TI products. TI's provision of these resources does not expand or otherwise alter TI's applicable warranties or warranty disclaimers for TI products.

Mailing Address: Texas Instruments, Post Office Box 655303, Dallas, Texas 75265  
Copyright © 2018, Texas Instruments Incorporated

## Looking for pricing, stock, or lifecycle information?

Click below to explore more details on WIN SOURCE:

 [View DAC5652AIPFBR on WIN SOURCE](#)

 [Texas Instruments](#) Information

## Optimize Your Supply Chain with WIN SOURCE Solutions

-  Global Sourcing Solution
-  Obsolete Management
-  Cost Control Management
-  Shortage Management
-  Alternative Solution
-  Excess Inventory Management