



**THE DATASHEET OF
SPM7054VT-1R5M-D**



SNx407 and SNx417 Hex Buffers and Drivers With Open-Collector High-Voltage Outputs

1 Features

- Convert TTL Voltage Levels to MOS Levels
- High Sink-Current Capability Design
- Open-Collector Driver for Indicator Lamps
- Inputs Fully Compatible With Most TTL Circuits
- On Products Compliant to MIL-PRF-38535, All Parameters Are Tested Unless Otherwise Noted. On All Other Products, Production Processing Does Not Necessarily Include Testing of All Parameters.

2 Applications

- Audio Docks: Portable
- Blu-ray Disc[®] Players and Home Theaters
- MP3 Players or Recorders
- Personal Digital Assistants (PDAs)
- Power: Telecom and Server AC or DC Supply: Single Controllers: Analog and Digital
- Solid-State Drive (SSD): Client and Enterprise
- TV: LCD, Digital, and High-Definition (HDTV)
- Tablets: Enterprise
- Video Analytics: Servers
- Wireless Headsets, Keyboards, and Mice

3 Description

These TTL hex buffers and drivers feature high-voltage open-collector outputs for interfacing with high-level circuits (such as MOS) or for driving high-current loads (such as lamps or relays), and also are characterized for use as buffers for driving TTL inputs. The SN5407 and SN7407 devices have minimum breakdown voltages of 30 V, and the SN5417 and SN7417 devices have minimum breakdown voltages of 15 V. The maximum sink current is 30 mA for the SN5407 and SN5417 devices and 40 mA for the SN7407 and SN7417 devices.

These devices perform the Boolean function $Y = A$ in positive logic.

These circuits are completely compatible with most TTL families. Inputs are diode clamped to minimize transmission-line effects, which simplifies design. Typical power dissipation is 145 mW, and average propagation delay time is 14 ns.

Device Information⁽¹⁾

PART NUMBER	PACKAGE	BODY SIZE (NOM)
SNx407J, SNx417J	CDIP (14)	19.56 mm × 6.92 mm
SN74x7D	SOIC (14)	8.65 mm × 3.91 mm
SN74x7N	PDIP (14)	19.30 mm × 6.35 mm
SNJ5407FK	LCCC (20)	8.89 mm × 8.89 mm
SNJ5407W	CFP (14)	9.21 mm × 5.97 mm

(1) For all available packages, see the orderable addendum at the end of the data sheet.

Logic Diagram, Each Buffer and Driver (Positive Logic)



Copyright © 2016,
Texas Instruments Incorporated



Table of Contents

1 Features	1	8.4 Device Functional Modes.....	8
2 Applications	1	9 Application and Implementation	9
3 Description	1	9.1 Application Information.....	9
4 Revision History	2	9.2 Typical Application	9
5 Pin Configuration and Functions	3	10 Power Supply Recommendations	10
6 Specifications	4	11 Layout	10
6.1 Absolute Maximum Ratings	4	11.1 Layout Guidelines	10
6.2 ESD Ratings.....	4	11.2 Layout Example	10
6.3 Recommended Operating Conditions.....	4	12 Device and Documentation Support	11
6.4 Thermal Information	5	12.1 Documentation Support	11
6.5 Electrical Characteristics.....	5	12.2 Related Links	11
6.6 Switching Characteristics	5	12.3 Receiving Notification of Documentation Updates	11
6.7 Typical Characteristics	6	12.4 Community Resources.....	11
7 Parameter Measurement Information	7	12.5 Trademarks	11
8 Detailed Description	8	12.6 Electrostatic Discharge Caution.....	11
8.1 Overview	8	12.7 Glossary	11
8.2 Functional Block Diagram	8	13 Mechanical, Packaging, and Orderable	
8.3 Feature Description.....	8	Information	12

4 Revision History

NOTE: Page numbers for previous revisions may differ from page numbers in the current version.

Changes from Revision G (May 2004) to Revision H	Page
• Added <i>ESD Ratings</i> table, <i>Feature Description</i> section, <i>Device Functional Modes</i> , <i>Application and Implementation</i> section, <i>Power Supply Recommendations</i> section, <i>Layout</i> section, <i>Device and Documentation Support</i> section, and <i>Mechanical, Packaging, and Orderable Information</i> section.	1
• Deleted <i>Ordering Information</i> table; see POA at the end of the data sheet.....	1
• Added Military Disclaimer to Features.....	1
• Changed $R_{\theta JA}$ values for SN7404: D (SOIC) from 86 to 86.8, N (PDIP) from 80 to 52.1, and NS (SO) from 76 to 85.9.....	5

5 Pin Configuration and Functions

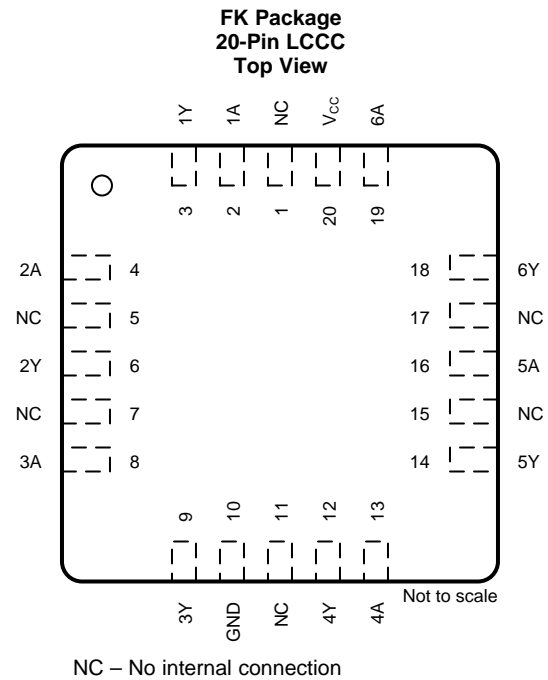
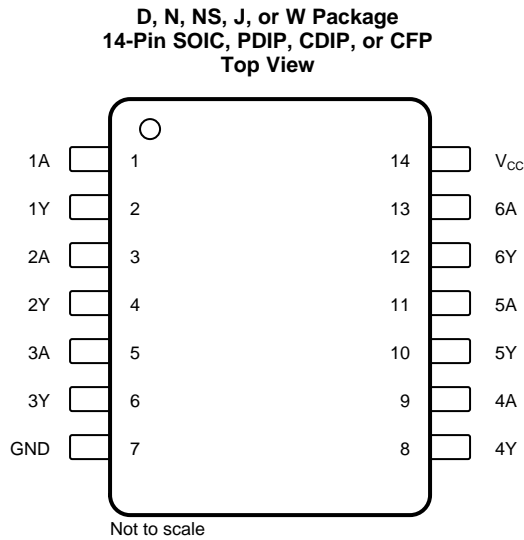

Pin Functions

NAME	PIN		I/O	DESCRIPTION
	SOIC, PDIP, CDIP, CFP	LCCC		
1A	1	2	I	Input 1
1Y	2	3	O	Output 1
2A	3	4	I	Input 2
2Y	4	6	O	Output 2
3A	5	8	I	Input 3
3Y	6	9	O	Output 3
4A	9	13	I	Input 4
4Y	8	12	O	Output 4
5A	11	16	I	Input 5
5Y	10	14	O	Output 5
6A	13	19	I	Input 6
6Y	12	18	O	Output 6
GND	7	10	—	Ground Pin
NC	—	1, 5, 7, 11, 15, 17	—	No Connect
V _{CC}	14	20	—	Power Pin

6 Specifications

6.1 Absolute Maximum Ratings

 over operating free-air temperature range (unless otherwise noted)⁽¹⁾

			MIN	MAX	UNIT
V _{CC}	Supply voltage			7	V
V _I	Input voltage ⁽²⁾			5.5	V
V _O	Output voltage ⁽²⁾⁽³⁾	SN5407, SN7407		30	V
		SN5417, SN7417		15	
T _J	Junction temperature			150	°C
T _{stg}	Storage temperature		–65	150	°C

- (1) Stresses beyond those listed under *Absolute Maximum Ratings* may cause permanent damage to the device. These are stress ratings only, and functional operation of the device at these or any other conditions beyond those indicated under *Recommended Operating Conditions* is not implied. Exposure to absolute-maximum-rated conditions for extended periods may affect device reliability.
- (2) All voltage values are with respect to GND.
- (3) This is the maximum voltage that can safely be applied to any output when it is in the OFF state.

6.2 ESD Ratings

			VALUE	UNIT
SN7407 AND SN7417				
V _(ESD)	Electrostatic discharge	Human-body model (HBM), per ANSI/ESDA/JEDEC JS-001 ⁽¹⁾	±2000	V
		Charged-device model (CDM), per JEDEC specification JESD22-C101 ⁽²⁾	±1000	
SN5407 AND SN5417				
V _(ESD)	Electrostatic discharge	Human-body model (HBM)	±2000	V

- (1) JEDEC document JEP155 states that 500-V HBM allows safe manufacturing with a standard ESD control process.
- (2) JEDEC document JEP157 states that 250-V CDM allows safe manufacturing with a standard ESD control process.

6.3 Recommended Operating Conditions

 over operating free-air temperature range (unless otherwise noted)⁽¹⁾

			MIN	NOM	MAX	UNIT
V _{CC}	Supply voltage	SN5407, SN5417	4.5	5	5.5	V
		SN7407, SN7417	4.75	5	5.25	
V _{IH}	High-level input voltage		2			V
V _{IL}	Low-level input voltage				0.8	V
V _{OH}	High-level output voltage	SN5407, SN7407			30	V
		SN5417, SN7417			15	
I _{OL}	Low-level output current	SN5407, SN5417			30	mA
		SN7407, SN7417			40	
T _A	Operating free-air temperature	SN5407, SN5417	–55		125	°C
		SN7407, SN7417	0		70	

- (1) All unused inputs of the device must be held at V_{CC} or GND to ensure proper device operation. See [Implications of Slow or Floating CMOS Inputs](#).

6.4 Thermal Information

THERMAL METRIC ⁽¹⁾	SN7407			SN7417		UNIT
	D (SOIC)	N (PDIP)	NS (SO)	D (SOIC)	N (PDIP)	
	14 PINS	14 PINS	14 PINS	14 PINS	14 PINS	
$R_{\theta JA}$ Junction-to-ambient thermal resistance ⁽²⁾	86.8	52.1	85.9	88.8	52.1	°C/W
$R_{\theta JC(top)}$ Junction-to-case (top) thermal resistance	47.1	39.4	43.9	50.4	39.4	°C/W
$R_{\theta JB}$ Junction-to-board thermal resistance	41	32	44.7	43	32	°C/W
ψ_{JT} Junction-to-top characterization parameter	15.6	24.2	14.6	16.5	24.2	°C/W
ψ_{JB} Junction-to-board characterization parameter	40.8	31.8	44.4	42.8	31.8	°C/W

(1) For more information about traditional and new thermal metrics, see the [Semiconductor and IC Package Thermal Metrics](#) application report.

(2) The package thermal impedance is calculated in accordance with JESD 51-7.

6.5 Electrical Characteristics

over recommended operating free-air temperature range (unless otherwise noted)⁽¹⁾⁽²⁾

PARAMETER	TEST CONDITIONS	MIN	TYP	MAX	UNIT
V_{IK} Input clamp voltage	$V_{CC} = \text{MIN}$, $I_I = -12 \text{ mA}$			-1.5	V
V_{OL} Low-level output voltage	$V_{CC} = \text{MIN}$, $V_{IL} = 0.8 \text{ V}$	$I_{OL} = 16 \text{ mA}$		0.4	V
		$I_{OL} = 30 \text{ mA}$, SN5407, SN5417		0.7	
		$I_{OL} = 40 \text{ mA}$, SN7407, SN7417		0.7	
I_{OH} High-level output current	$V_{CC} = \text{MIN}$, $V_{IH} = 2 \text{ V}$	$V_{OH} = 30 \text{ V}$, SN5407, SN7407		0.25	mA
		$V_{OH} = 15 \text{ V}$, SN5417, SN7417		0.25	
I_I Input current	$V_{CC} = \text{MAX}$, $V_I = 5.5 \text{ V}$			1	mA
I_{IH} High-level input current	$V_{CC} = \text{MAX}$, $V_{IH} = 2.4 \text{ V}$			40	μA
I_{IL} Low-level input current	$V_{CC} = \text{MAX}$, $V_{IL} = 0.4 \text{ V}$			-1.6	mA
I_{CCH} High-level supply current	$V_{CC} = \text{MAX}$		29	41	mA
I_{CCL} Low-level supply current	$V_{CC} = \text{MAX}$		21	30	mA

(1) All typical values are at $V_{CC} = 5 \text{ V}$, $T_A = 25^\circ\text{C}$.

(2) For conditions shown as MIN or MAX, use the appropriate value specified under recommended operating conditions.

6.6 Switching Characteristics

$V_{CC} = 5 \text{ V}$, $T_A = 25^\circ\text{C}$ (see [Figure 2](#))

PARAMETER	FROM (INPUT)	TO (OUTPUT)	TEST CONDITIONS	MIN	TYP	MAX	UNIT
t_{PLH}	A	Y	$R_L = 110 \Omega$, $C_L = 15 \text{ pF}$		6	10	ns
t_{PHL}					20	30	
t_{PLH}	A	Y	$R_L = 150 \Omega$, $C_L = 50 \text{ pF}$			15	ns
t_{PHL}						26	

6.7 Typical Characteristics

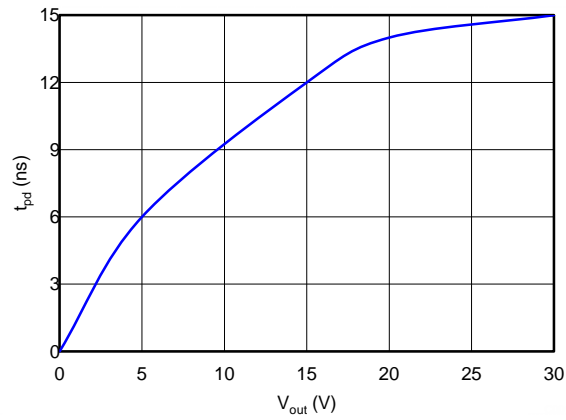
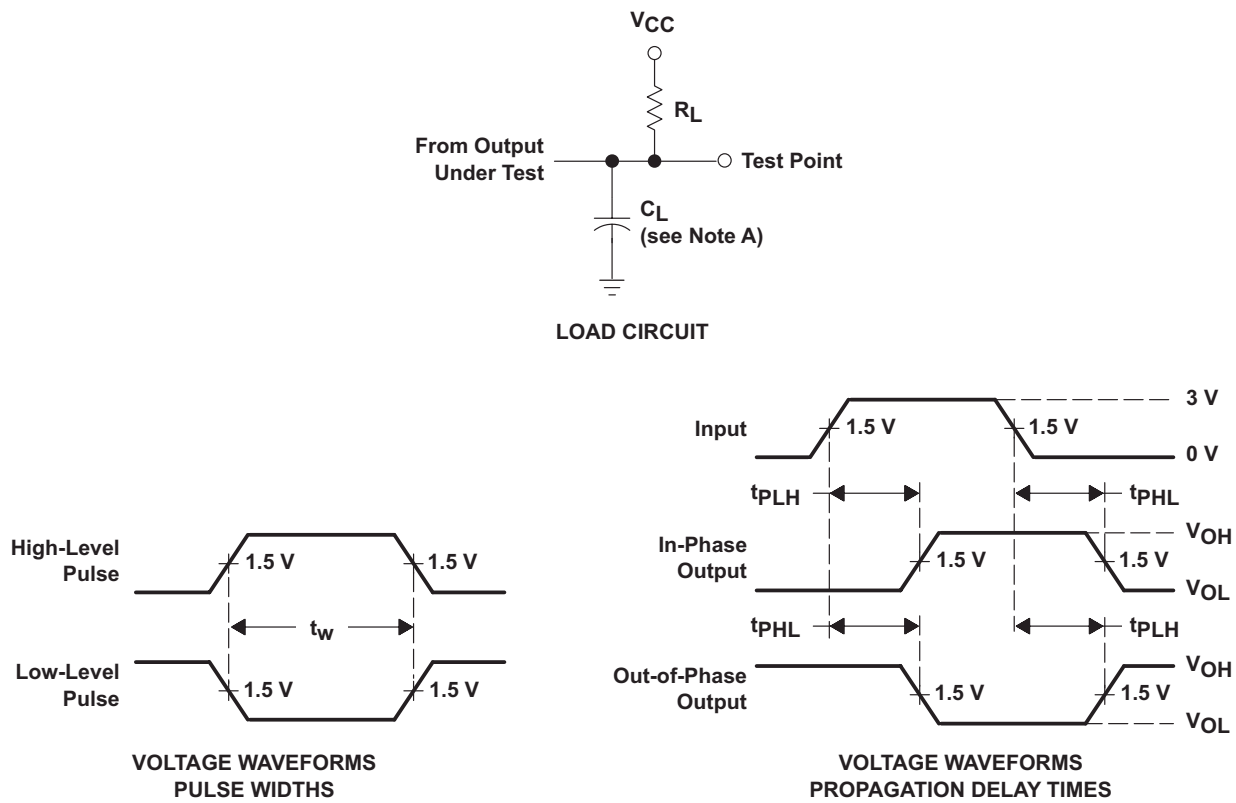

Figure 1. Time Low to High vs V_{OUT}

7 Parameter Measurement Information



- A. C_L includes probe and jig capacitance.
- B. In the examples above, the phase relationships between inputs and outputs have been chosen arbitrarily.
- C. All input pulses are supplied by generators having the following characteristics: $PRR \leq 1 \text{ MHz}$, $Z_O = 50 \Omega$, $t_r \leq 7 \text{ ns}$, $t_f \leq 7 \text{ ns}$.
- D. The outputs are measured one at a time, with one input transition per measurement.

Figure 2. Load Circuit and Voltage Waveforms

8 Detailed Description

8.1 Overview

The SN74x7 is a high sink current capable open-collector buffer. This device is high-voltage tolerant on the output of up to 30 V on the SNx407 model and 15 V on the SNx417 model. The SN74x7 is also useful for converting TTL voltage levels to MOS levels.

8.2 Functional Block Diagram

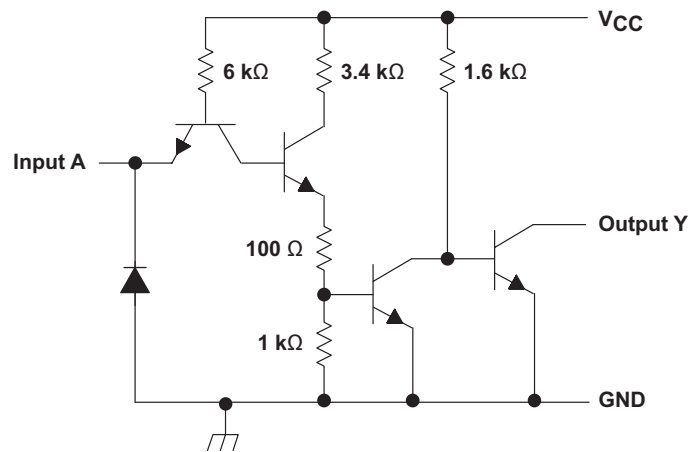

Copyright © 2016, Texas Instruments Incorporated

Resistor values shown are nominal.

Figure 3. Schematic

8.3 Feature Description

The SNx407 and SNx417 devices are ideal for high voltage outputs. The SNx407 device has a maximum output voltage 30 V and the SNx417 device has a maximum output voltage 15 V.

The high sink current is up to 40 mA for the SN74x7.

8.4 Device Functional Modes

[Table 1](#) lists the functions of the devices.

Table 1. Function Table

INPUT A	OUTPUT Y
H	High-Z
L	L

9 Application and Implementation

NOTE

Information in the following applications sections is not part of the TI component specification, and TI does not warrant its accuracy or completeness. TI's customers are responsible for determining suitability of components for their purposes. Customers should validate and test their design implementation to confirm system functionality.

9.1 Application Information

The SN74x7 device is a high-drive, open-collector device that is used for multiple buffer-type functions. The device produces 30 mA of drive current. Therefore, this device is ideal for driving multiple inputs and for high-speed applications up to 100 MHz. The outputs are high voltage tolerant up to 30 V for the SNx407.

9.2 Typical Application

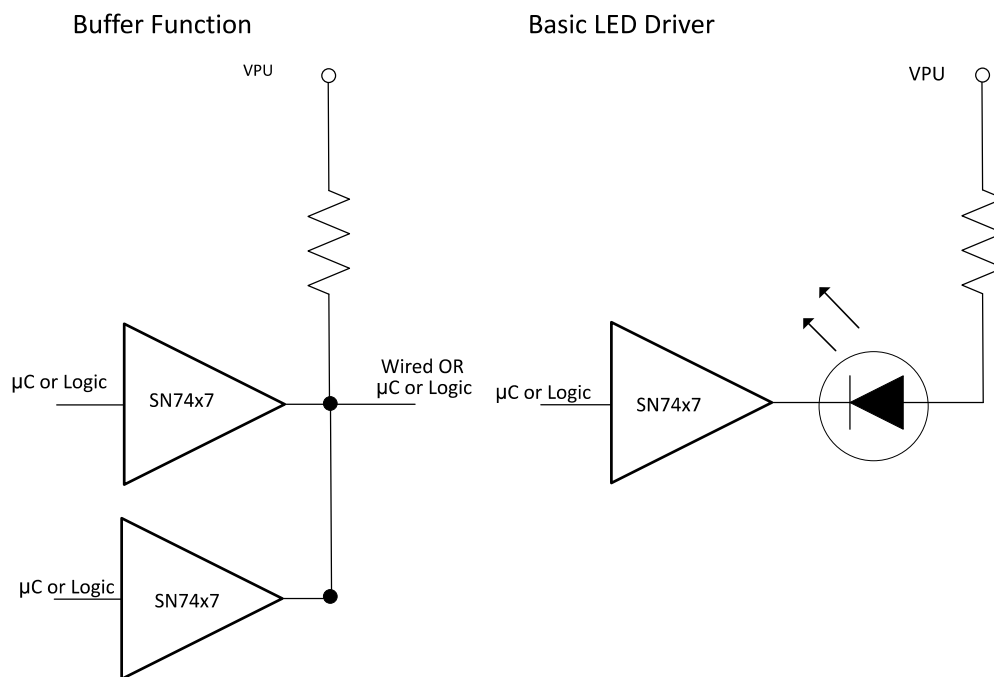

Copyright © 2016 Texas Instruments Incorporated

Figure 4. Typical Application Diagram

9.2.1 Design Requirements

Avoid bus contention because it can drive currents that would exceed maximum limits. The high drive also creates fast edges into light loads; therefore, routing and load conditions must be considered to prevent ringing.

9.2.2 Detailed Design Procedure

1. Recommended Input Conditions
 - Rise time and fall time specs: See t_{PHL} and t_{PLH} in [Switching Characteristics](#).
 - Specified high and low levels: See V_{IH} and V_{IL} in [Recommended Operating Conditions](#).
2. Recommend Output Conditions
 - Load currents must not exceed 30 mA.
 - Outputs must not be pulled above 30 V for the SNx407 device.

Typical Application (continued)

9.2.3 Application Curve

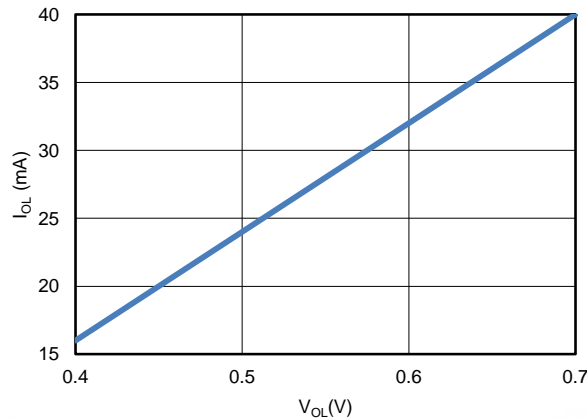

Figure 5. V_{OL} vs I_{OL}

10 Power Supply Recommendations

The power supply can be any voltage between the minimum and maximum supply voltage rating (see [Recommended Operating Conditions](#)).

Each V_{CC} pin must have a good bypass capacitor to prevent power disturbance. TI recommends 0.1 μF for devices with a single supply. If there are multiple V_{CC} pins, then TI recommends 0.01 μF or 0.022 μF for each power pin. It is acceptable to parallel multiple bypass capacitors to reject different frequencies of noise. A 0.1 μF and a 1 μF are commonly used in parallel. The bypass capacitor must be installed as close to the power pin as possible for best results.

11 Layout

11.1 Layout Guidelines

When using multiple bit logic devices inputs must never float.

In many cases, functions or parts of functions of digital logic devices are unused, for example, when only two inputs of a triple-input AND gate are used or only 3 of the 4 buffer gates are used. Such input pins must not be left unconnected because the undefined voltages at the outside connections result in undefined operational states. [Figure 6](#) specifies the rules that must be observed under all circumstances. All unused inputs of digital logic devices must be connected to a high or low bias to prevent them from floating. The logic level that must be applied to any particular unused input depends on the function of the device. Generally they are tied to GND or V_{CC} , whichever makes more sense or is more convenient. It is generally acceptable to float outputs, unless the part is a transceiver.

11.2 Layout Example

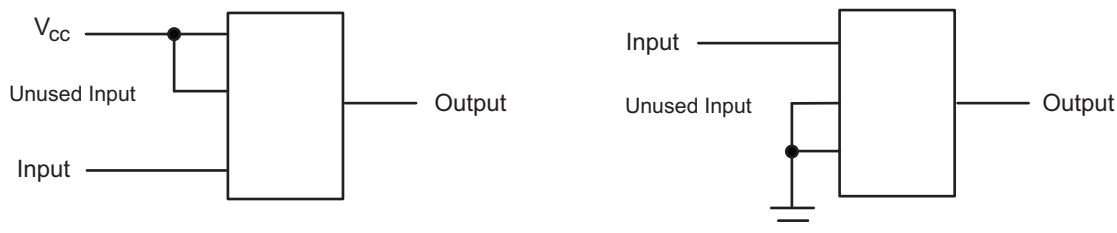

Figure 6. Layout Diagram

12 Device and Documentation Support

12.1 Documentation Support

12.1.1 Related Documentation

For related documentation see the following:

[Implications of Slow or Floating CMOS Inputs](#), (SCBA004)

12.2 Related Links

The table below lists quick access links. Categories include technical documents, support and community resources, tools and software, and quick access to sample or buy.

Table 2. Related Links

PARTS	PRODUCT FOLDER	SAMPLE & BUY	TECHNICAL DOCUMENTS	TOOLS & SOFTWARE	SUPPORT & COMMUNITY
SN5407	Click here	Click here	Click here	Click here	Click here
SN5417	Click here	Click here	Click here	Click here	Click here
SN7407	Click here	Click here	Click here	Click here	Click here
SN7417	Click here	Click here	Click here	Click here	Click here

12.3 Receiving Notification of Documentation Updates

To receive notification of documentation updates, navigate to the device product folder on ti.com. In the upper right corner, click on *Alert me* to register and receive a weekly digest of any product information that has changed. For change details, review the revision history included in any revised document.

12.4 Community Resources

The following links connect to TI community resources. Linked contents are provided "AS IS" by the respective contributors. They do not constitute TI specifications and do not necessarily reflect TI's views; see TI's [Terms of Use](#).

TI E2E™ Online Community *TI's Engineer-to-Engineer (E2E) Community*. Created to foster collaboration among engineers. At e2e.ti.com, you can ask questions, share knowledge, explore ideas and help solve problems with fellow engineers.

Design Support *TI's Design Support* Quickly find helpful E2E forums along with design support tools and contact information for technical support.

12.5 Trademarks

E2E is a trademark of Texas Instruments.

Blu-ray Disc is a registered trademark of Blue-ray Disc Association.

All other trademarks are the property of their respective owners.

12.6 Electrostatic Discharge Caution



This integrated circuit can be damaged by ESD. Texas Instruments recommends that all integrated circuits be handled with appropriate precautions. Failure to observe proper handling and installation procedures can cause damage.

ESD damage can range from subtle performance degradation to complete device failure. Precision integrated circuits may be more susceptible to damage because very small parametric changes could cause the device not to meet its published specifications.

12.7 Glossary

[SLYZ022](#) — *TI Glossary*.

This glossary lists and explains terms, acronyms, and definitions.

13 Mechanical, Packaging, and Orderable Information

The following pages include mechanical packaging and orderable information. This information is the most current data available for the designated devices. This data is subject to change without notice and revision of this document. For browser based versions of this data sheet, refer to the left hand navigation.

PACKAGING INFORMATION

Orderable Device	Status (1)	Package Type	Package Drawing	Pins	Package Qty	Eco Plan (2)	Lead finish/ Ball material (6)	MSL Peak Temp (3)	Op Temp (°C)	Device Marking (4/5)	Samples
JM38510/00803BCA	ACTIVE	CDIP	J	14	25	Non-RoHS & Green	SNPB	N / A for Pkg Type	-55 to 125	JM38510/ 00803BCA	Samples
JM38510/00803BDA	ACTIVE	CFP	W	14	25	Non-RoHS & Green	SNPB	N / A for Pkg Type	-55 to 125	JM38510/ 00803BDA	Samples
M38510/00803BCA	ACTIVE	CDIP	J	14	25	Non-RoHS & Green	SNPB	N / A for Pkg Type	-55 to 125	JM38510/ 00803BCA	Samples
M38510/00803BDA	ACTIVE	CFP	W	14	25	Non-RoHS & Green	SNPB	N / A for Pkg Type	-55 to 125	JM38510/ 00803BDA	Samples
SN5407J	ACTIVE	CDIP	J	14	25	Non-RoHS & Green	SNPB	N / A for Pkg Type	-55 to 125	SN5407J	Samples
SN5417J	ACTIVE	CDIP	J	14	25	Non-RoHS & Green	SNPB	N / A for Pkg Type	-55 to 125	SN5417J	Samples
SN7407DR	ACTIVE	SOIC	D	14	2500	RoHS & Green	NIPDAU	Level-1-260C-UNLIM	0 to 70	7407	Samples
SN7407DRE4	ACTIVE	SOIC	D	14	2500	RoHS & Green	NIPDAU	Level-1-260C-UNLIM	0 to 70	7407	Samples
SN7407DRG4	ACTIVE	SOIC	D	14	2500	RoHS & Green	NIPDAU	Level-1-260C-UNLIM	0 to 70	7407	Samples
SN7407N	ACTIVE	PDIP	N	14	25	RoHS & Green	NIPDAU	N / A for Pkg Type	0 to 70	SN7407N	Samples
SN7407NE4	ACTIVE	PDIP	N	14	25	RoHS & Green	NIPDAU	N / A for Pkg Type	0 to 70	SN7407N	Samples
SN7407NSR	ACTIVE	SO	NS	14	2000	RoHS & Green	NIPDAU	Level-1-260C-UNLIM	0 to 70	SN7407	Samples
SN7407NSRG4	ACTIVE	SO	NS	14	2000	RoHS & Green	NIPDAU	Level-1-260C-UNLIM	0 to 70	SN7407	Samples
SN7417DR	ACTIVE	SOIC	D	14	2500	RoHS & Green	NIPDAU	Level-1-260C-UNLIM	0 to 70	7417	Samples
SN7417N	ACTIVE	PDIP	N	14	25	RoHS & Green	NIPDAU	N / A for Pkg Type	0 to 70	SN7417N	Samples
SNJ5407FK	ACTIVE	LCCC	FK	20	55	Non-RoHS & Green	SNPB	N / A for Pkg Type	-55 to 125	SNJ5407FK	Samples
SNJ5407J	ACTIVE	CDIP	J	14	25	Non-RoHS & Green	SNPB	N / A for Pkg Type	-55 to 125	SNJ5407J	Samples
SNJ5407W	ACTIVE	CFP	W	14	25	Non-RoHS & Green	SNPB	N / A for Pkg Type	-55 to 125	SNJ5407W	Samples

Orderable Device	Status (1)	Package Type	Package Drawing	Pins	Package Qty	Eco Plan (2)	Lead finish/ Ball material (6)	MSL Peak Temp (3)	Op Temp (°C)	Device Marking (4/5)	Samples
SNJ5417J	ACTIVE	CDIP	J	14	25	Non-RoHS & Green	SNPB	N / A for Pkg Type	-55 to 125	SNJ5417J	Samples

(1) The marketing status values are defined as follows:

ACTIVE: Product device recommended for new designs.

LIFEBUY: TI has announced that the device will be discontinued, and a lifetime-buy period is in effect.

NRND: Not recommended for new designs. Device is in production to support existing customers, but TI does not recommend using this part in a new design.

PREVIEW: Device has been announced but is not in production. Samples may or may not be available.

OBSOLETE: TI has discontinued the production of the device.

(2) **RoHS:** TI defines "RoHS" to mean semiconductor products that are compliant with the current EU RoHS requirements for all 10 RoHS substances, including the requirement that RoHS substance do not exceed 0.1% by weight in homogeneous materials. Where designed to be soldered at high temperatures, "RoHS" products are suitable for use in specified lead-free processes. TI may reference these types of products as "Pb-Free".

RoHS Exempt: TI defines "RoHS Exempt" to mean products that contain lead but are compliant with EU RoHS pursuant to a specific EU RoHS exemption.

Green: TI defines "Green" to mean the content of Chlorine (Cl) and Bromine (Br) based flame retardants meet JS709B low halogen requirements of <=1000ppm threshold. Antimony trioxide based flame retardants must also meet the <=1000ppm threshold requirement.

(3) MSL, Peak Temp. - The Moisture Sensitivity Level rating according to the JEDEC industry standard classifications, and peak solder temperature.

(4) There may be additional marking, which relates to the logo, the lot trace code information, or the environmental category on the device.

(5) Multiple Device Markings will be inside parentheses. Only one Device Marking contained in parentheses and separated by a "~" will appear on a device. If a line is indented then it is a continuation of the previous line and the two combined represent the entire Device Marking for that device.

(6) Lead finish/Ball material - Orderable Devices may have multiple material finish options. Finish options are separated by a vertical ruled line. Lead finish/Ball material values may wrap to two lines if the finish value exceeds the maximum column width.

Important Information and Disclaimer:The information provided on this page represents TI's knowledge and belief as of the date that it is provided. TI bases its knowledge and belief on information provided by third parties, and makes no representation or warranty as to the accuracy of such information. Efforts are underway to better integrate information from third parties. TI has taken and continues to take reasonable steps to provide representative and accurate information but may not have conducted destructive testing or chemical analysis on incoming materials and chemicals. TI and TI suppliers consider certain information to be proprietary, and thus CAS numbers and other limited information may not be available for release.

In no event shall TI's liability arising out of such information exceed the total purchase price of the TI part(s) at issue in this document sold by TI to Customer on an annual basis.

OTHER QUALIFIED VERSIONS OF SN5407, SN5417, SN7407, SN7417 :

- Catalog : [SN7407](#), [SN7417](#)
- Military : [SN5407](#), [SN5417](#)

NOTE: Qualified Version Definitions:

- Catalog - TI's standard catalog product
- Military - QML certified for Military and Defense Applications

TAPE AND REEL INFORMATION

QUADRANT ASSIGNMENTS FOR PIN 1 ORIENTATION IN TAPE

*All dimensions are nominal

Device	Package Type	Package Drawing	Pins	SPQ	Reel Diameter (mm)	Reel Width W1 (mm)	A0 (mm)	B0 (mm)	K0 (mm)	P1 (mm)	W (mm)	Pin1 Quadrant
SN7407DR	SOIC	D	14	2500	330.0	16.4	6.5	9.0	2.1	8.0	16.0	Q1
SN7407DR	SOIC	D	14	2500	330.0	16.4	6.5	9.0	2.1	8.0	16.0	Q1
SN7407NSR	SO	NS	14	2000	330.0	16.4	8.2	10.5	2.5	12.0	16.0	Q1
SN7417DR	SOIC	D	14	2500	330.0	16.4	6.5	9.0	2.1	8.0	16.0	Q1

TAPE AND REEL BOX DIMENSIONS

*All dimensions are nominal

Device	Package Type	Package Drawing	Pins	SPQ	Length (mm)	Width (mm)	Height (mm)
SN7407DR	SOIC	D	14	2500	356.0	356.0	35.0
SN7407DR	SOIC	D	14	2500	340.5	336.1	32.0
SN7407NSR	SO	NS	14	2000	356.0	356.0	35.0
SN7417DR	SOIC	D	14	2500	356.0	356.0	35.0

TUBE

*All dimensions are nominal

Device	Package Name	Package Type	Pins	SPQ	L (mm)	W (mm)	T (μm)	B (mm)
JM38510/00803BDA	W	CFP	14	25	506.98	26.16	6220	NA
M38510/00803BDA	W	CFP	14	25	506.98	26.16	6220	NA
SN7407N	N	PDIP	14	25	506	13.97	11230	4.32
SN7407N	N	PDIP	14	25	506	13.97	11230	4.32
SN7407NE4	N	PDIP	14	25	506	13.97	11230	4.32
SN7407NE4	N	PDIP	14	25	506	13.97	11230	4.32
SN7417N	N	PDIP	14	25	506	13.97	11230	4.32
SN7417N	N	PDIP	14	25	506	13.97	11230	4.32
SNJ5407FK	FK	LCCC	20	55	506.98	12.06	2030	NA
SNJ5407W	W	CFP	14	25	506.98	26.16	6220	NA

MECHANICAL DATA

NS (R-PDSO-G**)

PLASTIC SMALL-OUTLINE PACKAGE

14-PINS SHOWN



- NOTES:
- A. All linear dimensions are in millimeters.
 - B. This drawing is subject to change without notice.
 - C. Body dimensions do not include mold flash or protrusion, not to exceed 0,15.

W (R-GDFP-F14)

CERAMIC DUAL FLATPACK



- NOTES:
- A. All linear dimensions are in inches (millimeters).
 - B. This drawing is subject to change without notice.
 - C. This package can be hermetically sealed with a ceramic lid using glass frit.
 - D. Index point is provided on cap for terminal identification only.
 - E. Falls within MIL STD 1835 GDFP1-F14

GENERIC PACKAGE VIEW

FK 20

LCCC - 2.03 mm max height

8.89 x 8.89, 1.27 mm pitch

LEADLESS CERAMIC CHIP CARRIER

This image is a representation of the package family, actual package may vary.
Refer to the product data sheet for package details.



4229370VA\

J 14

GENERIC PACKAGE VIEW
CDIP - 5.08 mm max height
CERAMIC DUAL IN LINE PACKAGE



Images above are just a representation of the package family, actual package may vary.
Refer to the product data sheet for package details.

4040083-5/G

EXAMPLE BOARD LAYOUT

J0014A

CDIP - 5.08 mm max height

CERAMIC DUAL IN LINE PACKAGE



LAND PATTERN EXAMPLE
NON-SOLDER MASK DEFINED
SCALE: 5X



4214771/A 05/2017

D (R-PDSO-G14)

PLASTIC SMALL OUTLINE



- NOTES:
- A. All linear dimensions are in inches (millimeters).
 - B. This drawing is subject to change without notice.
 -  Body length does not include mold flash, protrusions, or gate burrs. Mold flash, protrusions, or gate burrs shall not exceed 0.006 (0,15) each side.
 -  Body width does not include interlead flash. Interlead flash shall not exceed 0.017 (0,43) each side.
 - E. Reference JEDEC MS-012 variation AB.

D (R-PDSO-G14)

PLASTIC SMALL OUTLINE

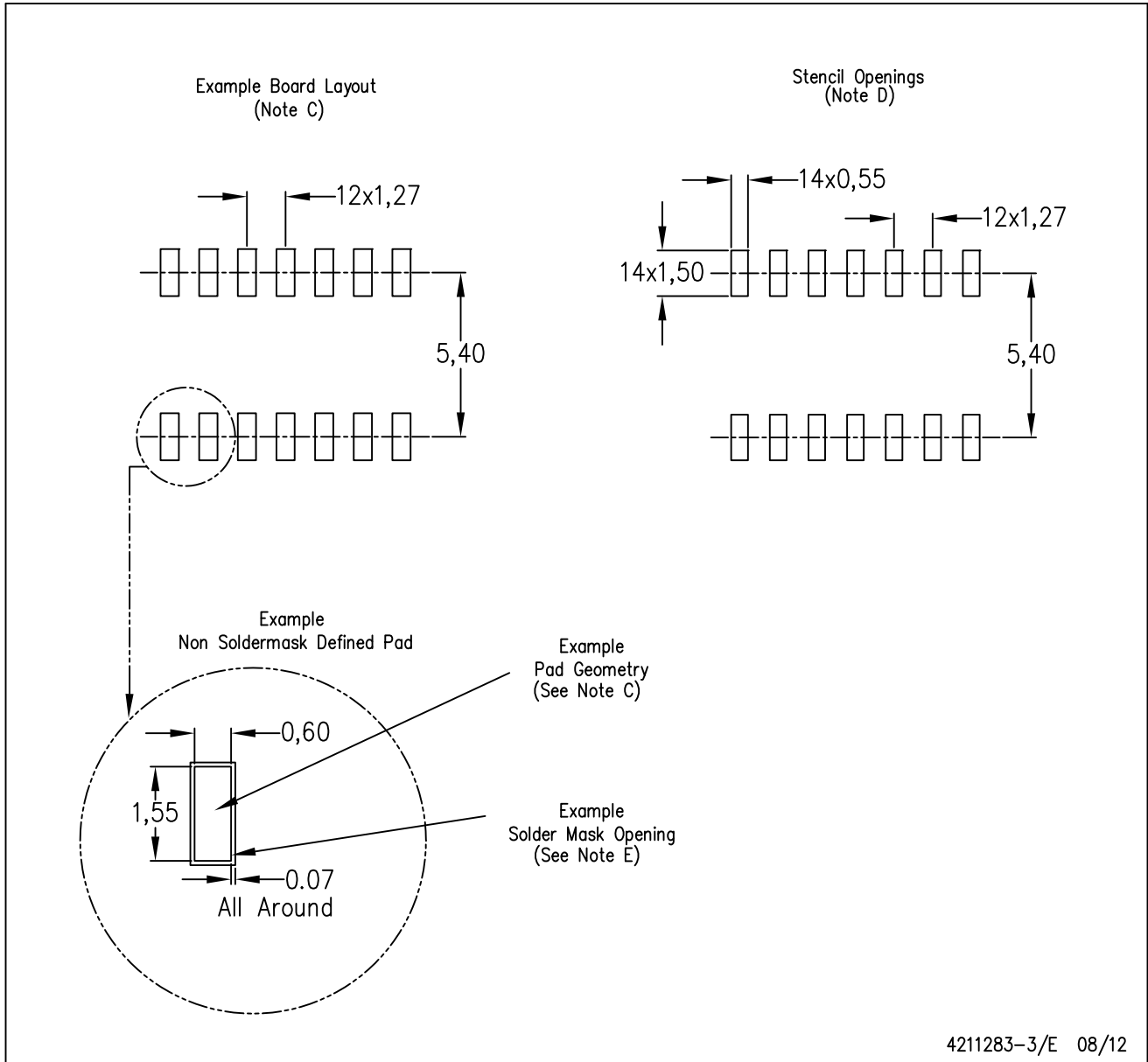

- NOTES:
- All linear dimensions are in millimeters.
 - This drawing is subject to change without notice.
 - Publication IPC-7351 is recommended for alternate designs.
 - Laser cutting apertures with trapezoidal walls and also rounding corners will offer better paste release. Customers should contact their board assembly site for stencil design recommendations. Refer to IPC-7525 for other stencil recommendations.
 - Customers should contact their board fabrication site for solder mask tolerances between and around signal pads.

N (R-PDIP-T**)

PLASTIC DUAL-IN-LINE PACKAGE

16 PINS SHOWN



- NOTES:
- A. All linear dimensions are in inches (millimeters).
 - B. This drawing is subject to change without notice.
 - (C) Falls within JEDEC MS-001, except 18 and 20 pin minimum body length (Dim A).
 - (D) The 20 pin end lead shoulder width is a vendor option, either half or full width.

IMPORTANT NOTICE AND DISCLAIMER

TI PROVIDES TECHNICAL AND RELIABILITY DATA (INCLUDING DATA SHEETS), DESIGN RESOURCES (INCLUDING REFERENCE DESIGNS), APPLICATION OR OTHER DESIGN ADVICE, WEB TOOLS, SAFETY INFORMATION, AND OTHER RESOURCES "AS IS" AND WITH ALL FAULTS, AND DISCLAIMS ALL WARRANTIES, EXPRESS AND IMPLIED, INCLUDING WITHOUT LIMITATION ANY IMPLIED WARRANTIES OF MERCHANTABILITY, FITNESS FOR A PARTICULAR PURPOSE OR NON-INFRINGEMENT OF THIRD PARTY INTELLECTUAL PROPERTY RIGHTS.

These resources are intended for skilled developers designing with TI products. You are solely responsible for (1) selecting the appropriate TI products for your application, (2) designing, validating and testing your application, and (3) ensuring your application meets applicable standards, and any other safety, security, regulatory or other requirements.

These resources are subject to change without notice. TI grants you permission to use these resources only for development of an application that uses the TI products described in the resource. Other reproduction and display of these resources is prohibited. No license is granted to any other TI intellectual property right or to any third party intellectual property right. TI disclaims responsibility for, and you will fully indemnify TI and its representatives against, any claims, damages, costs, losses, and liabilities arising out of your use of these resources.

TI's products are provided subject to [TI's Terms of Sale](#) or other applicable terms available either on [ti.com](https://www.ti.com) or provided in conjunction with such TI products. TI's provision of these resources does not expand or otherwise alter TI's applicable warranties or warranty disclaimers for TI products.

TI objects to and rejects any additional or different terms you may have proposed.

Mailing Address: Texas Instruments, Post Office Box 655303, Dallas, Texas 75265
Copyright © 2024, Texas Instruments Incorporated

Looking for pricing, stock, or lifecycle information?

Click below to explore more details on WIN SOURCE:

 [View SPM7054VT-1R5M-D on WIN SOURCE](#)

 [TDK Corporation](#) Information

Optimize Your Supply Chain with WIN SOURCE Solutions

-  Global Sourcing Solution
-  Obsolete Management
-  Cost Control Management
-  Shortage Management
-  Alternative Solution
-  Excess Inventory Management