



THE DATASHEET OF SL28540ALC



Low Power Clock Generator for Intel® Mobile Platform

Features

- Compliant to Intel® CK540 UMPC clock spec
- Low power push-pull type differential output buffers
- Integrated voltage regulator
- Integrated series termination resistors on differential clocks
- Scalable low voltage VDD_IO (3.3V to 1.05V)
- 8-step drive strength control for all single-ended clocks
- Differential CPU clocks with selectable frequency
- 100 MHz Differential SRC clocks
- 96 MHz Differential DOT clock
- 48 MHz USB clocks
- 33 MHz PCI clocks
- Buffered Reference Clock 14.318 MHz
- Low-voltage frequency select input
- I²C support with readback capabilities
- Ideal Lexmark Spread Spectrum profile for maximum electromagnetic interference (EMI) reduction
- 56-pin QFN (8x8) package

CPU	SRC	PCI	REF	DOT96	USB_48	LCD
x2 / x3	x7	x6	x 1	x 1	x 1	x1

Block Diagram

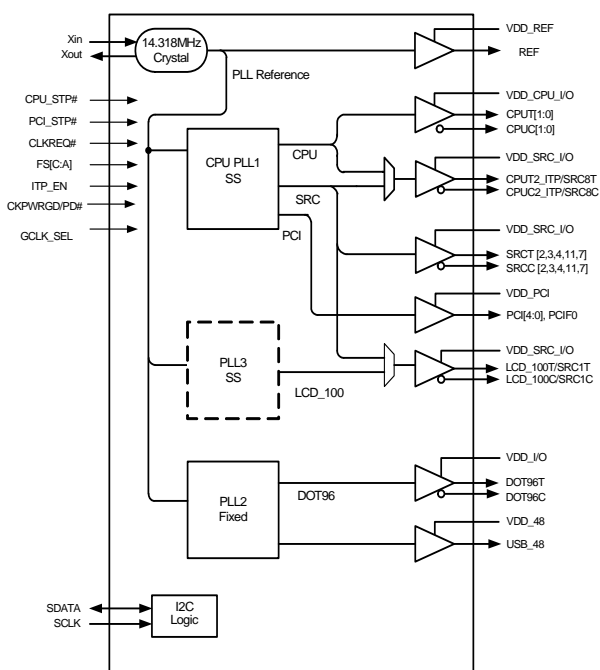

Pin Configuration

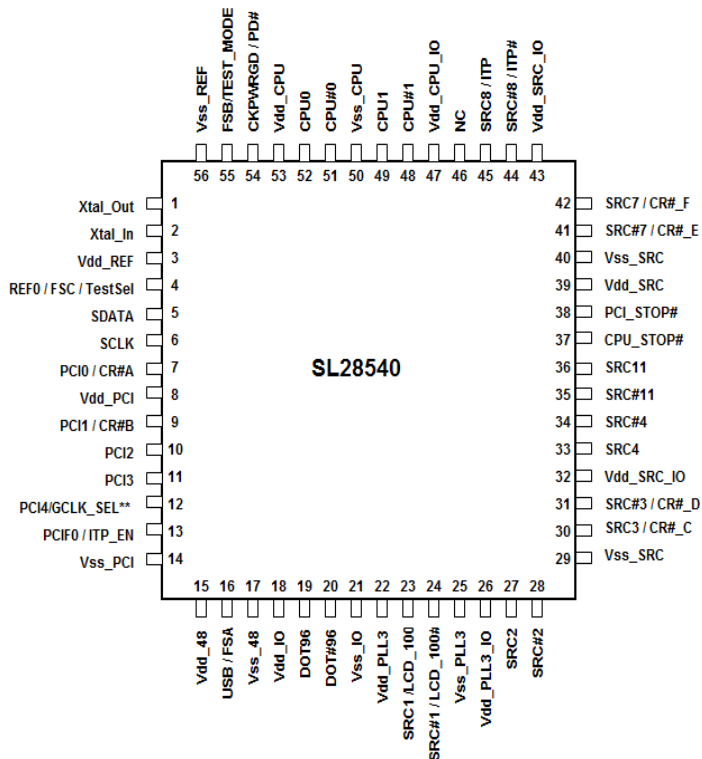

* internal Pull-up
** internal Pull-down

Pin Definitions

Pin No.	Name	Type	Description
1	Xout	O, SE	14.318 MHz Crystal output.
2	Xin	I	14.318 MHz Crystal input.
3	VDD_REF	PWR	3.3V Power supply for outputs and maintains SMBUS registers during power down.
4	REF0 / FSC / TEST_SEL	I/O	Fixed 14.318 clock output/3.3V-tolerant input for CPU frequency selection/ Selects test mode if pulled to V_{IHFS_C} when CK_PWRGD is asserted HIGH. Refer to DC Electrical Specifications table for V _{ILFS_C} , V _{IMFS_C} , V _{IHFS_C} specifications.
5	SDATA	I/O	SMBus compatible SDATA.
6	SCLK	I	SMBus compatible SCLOCK.
7	PCI0 / CR#_A	I/O, SE	33 MHz Clock/3.3V Clock Request # Input Mappable via I2C to control either SRC 0 or SRC 2. Default PCI0. To configure this pin to serve as a Clock Request pin for either SRC pair 2 or pair 0 using the CR#_A_EN bit located in byte 5 bit 7, first disable PCI output (Hi-z) in byte 2, bit 1. 0 = PCI0 enabled (default) 1 = CR#_A enabled. Byte 5, bit 6 controls whether CR#_A controls SRC0 or SRC2 pair Byte 5, bit 6: 0 = CR#_A controls SRC0 pair (default) 1 = CR#_A controls SRC2 pair
8	VDD_PCI	PWR	3.3V power supply for PCI PLL
9	PCI1 / CR#_B	I/O, SE	33 MHz Clock/3.3V Clock Request # Input Mappable via I2C to control either SRC 1 or SRC 4. Default PCI1. To configure this pin to serve as a Clock Request pin for either SRC pair 1 or pair 4 using the CR#_B_EN bit located in byte 5, bit 5, first disable PCI output (Hi-z) in byte 2, bit 1. 0 = PCI1 enabled (default) 1 = CR#_B enabled. Byte 5, bit 4 controls whether CR#_B controls SRC1 or SRC4 pair Byte 5, bit 4: 0 = CR#_B controls SRC1 pair (default) 1 = CR#_B controls SRC4 pair
10	PCI2	O, SE	33 MHz Clock output/3.3V-tolerant input for enabling Trusted Mode
11	PCI3	O, SE	33 MHz Clock output
11, 12	PCI 4/GCLK_SEL	I/O, SE PD	33 MHz Clock output/3.3V-tolerant input for selecting clock source on pin 23, 24. Sampled at CKPWRGD assertion: 0 = SRC1(default), 1 = LCD_100M Internal weak pull-down to GND
13	PCIF0 / ITP_EN	I/O, SE	33 MHz free running clock output/3.3V LVTTTL input to enable SRC8 or CPU2_ITP (sampled on the CKPWRGD assertion) 1 = CPU2_ITP, 0 = SRC8
14	VSS_PCI	GND	Ground for outputs.
15	VDD_48	PWR	3.3V power supply for outputs and PLL.
16	USB_48 / FSA	I/O	Fixed 48 MHz clock output/3.3V-tolerant input for CPU frequency selection Refer to DC Electrical Specifications table for V _{il_FS} and V _{Ih_FS} specifications.
17	VSS_48	GND	Ground for outputs.
18	VDD_IO	PWR	3.3V-1.05V power supply for outputs
19	DOT96T	O, DIF	Fixed True 96 MHz clock output.
20	DOT96C	O, DIF	Fixed complement 96 MHz clock output.

Pin Definitions (continued)

Pin No.	Name	Type	Description
21	VSS_IO	GND	Ground for outputs.
22	VDD_PLL3	PWR	3.3V Power supply for PLL3.
23	SRCT1 / LCDT_100	O, DIF	True 100 MHz differential serial reference clock output/True 100 MHz LCD video clock output
24	SRCC1 / LCDC_100	O, DIF	Complementary 100 MHz differential serial reference clock output/Complementary 100 MHz LCD video clock output
25	VSS_PLL3	GND	Ground for PLL3.
26	VDD_PLL3_IO	PWR	3.3V-1.05V power supply for outputs.
27	SRCT2	O, DIF	True 100 MHz differential serial reference clock output.
28	SRCC2	O, DIF	Complementary 100 MHz differential serial reference clock output.
29	VSS_SRC	GND	Ground for outputs.
30	SRCT3 / CR#_C	I/O, DIF	True 100 MHz differential serial reference clock output /3.3V Clock Request #_C/D input Selected via CR#_C_EN/CR#_D_EN bit located in byte 5 bit 3 and 1. The CR#_C_SEL and CR#_D_SEL bits in byte 5 bit 2 and 0 will select which SRC to stop when asserted
31	SRCC3 / CR#_D	I/O, DIF	Complementary 100 MHz differential serial reference clock output/3.3V Clock Request #_C/D input Selected via CR#_C_EN/CR#_D_EN bit located in byte 5 bit 3 and 1. The CR#_C_SEL and CR#_D_SEL bits in byte 5 bit 2 and 0 will select which SRC to stop when asserted
32	VDD_SRC_IO	PWR	3.3V-1.05V Power supply for outputs.
33	SRCT4	O, DIF	True 100 MHz differential serial reference clocks.
34	SRCC4	O, DIF	Complementary 100 MHz differential serial reference clocks.
35	SRCT11	O, DIF	True 100 MHz differential serial reference clocks.
36	SRCC11	O, DIF	Complementary 100 MHz differential serial reference clocks.
37	CPU_STOP#	I	3.3V-tolerant input for stopping CPU outputs During direct clock off to M1 mode transition, a serial load of BSEL data is driven on CPU_STOP# and sampled on the rising edge of PCI_STOP#. See <i>Figure 12</i> for more information.
38	PCI_STOP#	I	3.3V-tolerant input for stopping PCI and SRC outputs During direct clock off to M1 mode transition, a serial load of BSEL data is driven on CPU_STOP# and sampled on the rising edge of PCI_STOP#. See <i>Figure 12</i> for more information.
39	VDD_SRC	PWR	3.3V power supply for SRC PLL.
40	VSS_SRC	GND	Ground for outputs.
41	SRCC7/ CR#_E	I/O, DIF	Complementary 100 MHz differential serial reference clocks/3.3V CR#_E Input. Selected via CR#_E_EN/CR#_F_EN bit located in byte 6 bit 7 and 6. When selected, CR#_E controls SRC6, CR#_F controls SRC8
42	SRCT7/ CR#_F	I/O, DIF	True 100 MHz differential serial reference clocks/3.3V CR#_F Input. Selected via CR#_E_EN/CR#_F_EN bit located in byte 6 bit 7 and 6. When selected, CR#_E controls SRC6, CR#_F controls SRC8
43	VDD_SRC_IO	PWR	3.3V-1.05V Power supply for outputs.
44	SRCC8 / CPUC2_ITP	O, DIF	Selectable complementary differential CPU or SRC clock output. ITP_EN = 0 @ CK_PWRGD assertion = SRC8 ITP_EN = 1 @ CK_PWRGD assertion = CPU2
45	SRCT8 / CPUT2_ITP,	O, DIF	Selectable True differential CPU or SRC clock output. ITP_EN = 0 @ CK_PWRGD assertion = SRC8 ITP_EN = 1 @ CK_PWRGD assertion = CPU2
46	NC	NC	No connect.

Pin Definitions (continued)

Pin No.	Name	Type	Description
47	VDD_CPU_IO	PWR	3.3V-1.05V Power supply for outputs.
48	CPUC1	O, DIF	Complementary differential CPU clock outputs. Note that CPU1 is the iAMT clock and is on in that mode.
49	CPUT1	O, DIF	True differential CPU clock outputs. Note that CPU1 is the iAMT clock and is on in that mode.
50	VSS_CPU	GND	Ground for outputs.
51	CPUC0	O, DIF	Complement differential CPU clock outputs.
52	CPUT0	O, DIF	True differential CPU clock outputs.
53	VDD_CPU	PWR	3.3V Power supply for CPU PLL.
54	CKPWRGD / PWRDWN#	I	3.3V LVTTTL input. This pin is a level sensitive strobe used to latch the FS_A, FS_B, FS_C, GLCK_SEL and ITP_EN. After CKPWRGD (active HIGH) assertion, this pin becomes a real-time input for asserting power down (active LOW).
55	FSB / TEST_MODE	I	3.3V-tolerant input for CPU frequency selection / Selects Ref/N or Tri-state when in test mode. 0 = Tri-state, 1 = Ref/N Refer to DC Electrical Specifications table for Vil_FS and Vih_FS specifications.
56	VSS_REF	GND	Ground for outputs.

Table 1. Frequency Select Pin (FSA, FSB and FSC)

FSC	FSB	FSA	CPU	SRC	PCIF/PCI	REF	DOT96	USB
1	0	1	100 MHz	100 MHz	33 MHz	14.318 MHz	96 MHz	48 MHz
0	0	1	133 MHz	100 MHz	33 MHz	14.318 MHz	96 MHz	48 MHz
0	1	1	166 MHz	100 MHz	33 MHz	14.318 MHz	96 MHz	48 MHz
0	1	0	200 MHz	100 MHz	33 MHz	14.318 MHz	96 MHz	48 MHz

Apply the appropriate logic levels to FSA, FSB, and FSC inputs before CK-PWRGD assertion to achieve host clock frequency selection. When the clock chip sampled HIGH on CK-PWRGD and indicates that VTT voltage is stable then FSA, FSB, and FSC input values are sampled. This process employs a one-shot functionality and once the CK-PWRGD sampled a valid HIGH, all other FSA, FSB, FSC, and CK-PWRGD transitions are ignored except in test mode

Serial Data Interface

To enhance the flexibility and function of the clock synthesizer, a two-signal serial interface is provided. Through the Serial Data Interface, various device functions, such as individual clock output buffers are individually enabled or disabled. The registers associated with the Serial Data Interface initialize to their default setting at power-up. The use of this interface is optional. Clock device register changes are normally made at

system initialization, if any are required. The interface cannot be used during system operation for power management functions.

Data Protocol

The clock driver serial protocol accepts byte write, byte read, block write, and block read operations from the controller. For block write/read operation, Access the bytes in sequential order from lowest to highest (most significant bit first) with the ability to stop after any complete byte is transferred. For byte write and byte read operations, the system controller can access individually indexed bytes. The offset of the indexed byte is encoded in the command code described in *Table 2*.

The block write and block read protocol is outlined in *Table 3* while *Table 4* outlines byte write and byte read protocol. The slave receiver address is 11010010 (D2h)

Table 2. Command Code Definition

Bit	Description
7	0 = Block read or block write operation, 1 = Byte read or byte write operation
(6:0)	Byte offset for byte read or byte write operation. For block read or block write operations, these bits should be '000000'



Table 3. Block Read and Block Write Protocol

Block Write Protocol		Block Read Protocol	
Bit	Description	Bit	Description
1	Start	1	Start
8:2	Slave address–7 bits	8:2	Slave address–7 bits
9	Write	9	Write
10	Acknowledge from slave	10	Acknowledge from slave
18:11	Command Code–8 bits	18:11	Command Code–8 bits
19	Acknowledge from slave	19	Acknowledge from slave
27:20	Byte Count–8 bits	20	Repeat start
28	Acknowledge from slave	27:21	Slave address–7 bits
36:29	Data byte 1–8 bits	28	Read = 1
37	Acknowledge from slave	29	Acknowledge from slave
45:38	Data byte 2–8 bits	37:30	Byte Count from slave–8 bits
46	Acknowledge from slave	38	Acknowledge
....	Data Byte /Slave Acknowledges	46:39	Data byte 1 from slave–8 bits
....	Data Byte N–8 bits	47	Acknowledge
....	Acknowledge from slave	55:48	Data byte 2 from slave–8 bits
....	Stop	56	Acknowledge
		Data bytes from slave / Acknowledge
		Data Byte N from slave–8 bits
		NOT Acknowledge
		Stop

Table 4. Byte Read and Byte Write Protocol

Byte Write Protocol		Byte Read Protocol	
Bit	Description	Bit	Description
1	Start	1	Start
8:2	Slave address–7 bits	8:2	Slave address–7 bits
9	Write	9	Write
10	Acknowledge from slave	10	Acknowledge from slave
18:11	Command Code–8 bits	18:11	Command Code–8 bits
19	Acknowledge from slave	19	Acknowledge from slave
27:20	Data byte–8 bits	20	Repeated start
28	Acknowledge from slave	27:21	Slave address–7 bits
29	Stop	28	Read
		29	Acknowledge from slave
		37:30	Data from slave–8 bits
		38	NOT Acknowledge
		39	Stop

Control Registers

Byte 0: Control Register 0

Bit	@Pup	Name	Description
7	HW	FS_C	CPU Frequency Select Bit, set by HW
6	HW	FS_B	CPU Frequency Select Bit, set by HW
5	HW	FS_A	CPU Frequency Select Bit, set by HW
4	0	iAMT_EN	Set via SMBus or by combination of PWRDWN, CPU_STP, and PCI_STP 0 = Legacy Mode, 1 = iAMT Enabled
3	0	Reserved	Reserved
2	0	Reserved	Reserved
1	0	Reserved	Reserved
0	1	PD_Restore	Save Config. In powerdown 0 = Config. Cleared, 1 = Config. Saved

Byte 1: Control Register 1

Bit	@Pup	Name	Description
7	0	Reserved	Reserved
6	0	PLL1_SS_DC	Select for down or center SS 0 = Down spread, 1 = Center spread
5	0	PLL3_SS_DC	Select for down or center SS 0 = Down spread, 1 = Center spread
4	0	PLL3_CFB3	See <i>Table 8</i> : PLL3 / SE configuration table
3	0	PLL3_CFB2	
2	0	PLL3_CFB1	
1	1	PLL3_CFB0	
0	1	Reserved	Reserved

Byte 2: Control Register 2

Bit	@Pup	Name	Description
7	1	REF_OE	Output enable for REF 0 = Output Disabled, 1 = Output Enabled
6	1	USB_OE	Output enable for USB 0 = Output Disabled, 1 = Output Enabled
5	1	PCIF0_OE	Output enable for PCIF0 0 = Output Disabled, 1 = Output Enabled
4	1	PCI4_OE	Output enable for PCI4 0 = Output Disabled, 1 = Output Enabled
3	1	PCI3_OE	Output enable for PCI3 0 = Output Disabled, 1 = Output Enabled
2	1	PCI2_OE	Output enable for PCI2 0 = Output Disabled, 1 = Output Enabled
1	1	PCI1_OE	Output enable for PCI1 0 = Output Disabled, 1 = Output Enabled
0	1	PCI0_OE	Output enable for PCI0 0 = Output Disabled, 1 = Output Enabled

Byte 3: Control Register 3

Bit	@Pup	Name	Description
-----	------	------	-------------

Byte 3: Control Register 3

7	1	SRC[T/C]11_OE	Output enable for SRC11 0 = Output Disabled, 1 = Output Enabled
6	1	Reserved	Reserved
5	1	Reserved	Reserved
4	1	SRC[T/C]8/CPU2_ITP_OE	Output enable for SRC8 or CPU2_ITP 0 = Output Disabled, 1 = Output Enabled
3	1	SRC[T/C]7_OE	Output enable for SRC7 0 = Output Disabled, 1 = Output Enabled
2	1	Reserved	Reserved
1	1	Reserved	Reserved
0	1	SRC[T/C]4_OE	Output enable for SRC4 0 = Output Disabled, 1 = Output Enabled

Byte 4: Control Register 4

Bit	@Pup	Name	Description
7	1	SRC[T/C]3_OE	Output enable for SRC3 0 = Output Disabled, 1 = Output Enabled
6	1	SRC[T/C]2_OE	Output enable for SRC2 0 = Output Disabled, 1 = Output Enabled
5	1	SRC[T/C]1/LCD_100M[T/C]_OE	Output enable for SRC1/LCD_100M 0 = Output Disabled, 1 = Output Enabled
4	1	DOT96[T/C]_OE	Output enable for DOT96 0 = Output Disabled, 1 = Output Enabled
3	1	CPU[T/C]1_OE	Output enable for CPU1 0 = Output Disabled, 1 = Output Enabled
2	1	CPU[T/C]0_OE	Output enable for CPU0 0 = Output Disabled, 1 = Output Enabled
1	1	PLL1_SS_EN	Enable PLL1's spread modulation, 0 = Spread Disabled, 1 = Spread Enabled
0	1	PLL3_SS_EN	Enable PLL3's spread modulation 0 = Spread Disabled, 1 = Spread Enabled

Byte 5: Control Register 5

Bit	@Pup	Name	Description
7	0	CR#_A_EN	Enable CR#_A (clk req) 0 = Disabled, 1 = Enabled,
6	0	CR#_A_SEL	Set CR#_A → SRC0 or SRC2 0 = CR#_A→SRC0, 1 = CR#_A→SRC2
5	0	CR#_B_EN	Enable CR#_B (clk req) 0 = Disabled, 1 = Enabled,
4	0	CR#_B_SEL	Set CR#_B → SRC1 or SRC4 0 = CR#_B→SRC1, 1 = CR#_B→SRC4
3	0	CR#_C_EN	Enable CR#_C (clk req) 0 = Disabled, 1 = Enabled
2	0	CR#_C_SEL	Set CR#_C → SRC0 or SRC2 0 = CR#_C→SRC0, 1 = CR#_C→SRC2
1	0	CR#_D_EN	Enable CR#_D (clk req) 0 = Disabled, 1 = Enabled
0	0	CR#_D_SEL	Set CR#_D → SRC1 or SRC4 0 = CR#_D→SRC1, 1 = CR#_D→SRC4

Byte 6: Control Register 6

Bit	@Pup	Name	Description
7	0	CR#_E_EN	Enable CR#_E (clk req) → SRC6 0 = Disabled, 1 = Enabled
6	0	CR#_F_EN	Enable CR#_F (clk req) → SRC8 0 = Disabled, 1 = Enabled
5	0	Reserved	Reserved
4	0	Reserved	Reserved
3	0	Reserved	Reserved
2	0	Reserved	Reserved
1	0	LCD_100_STP_CTRL	If set, LCD_100 stop with PCI_STOP# 0 = Free running, 1 = PCI_STOP# stoppable
0	0	SRC_STP_CTRL	If set, SRCs stop with PCI_STOP# 0 = Free running, 1 = PCI_STOP# stoppable

Byte 7: Vendor ID

Bit	@Pup	Name	Description
7	0	Rev Code Bit 3	Revision Code Bit 3
6	0	Rev Code Bit 2	Revision Code Bit 2
5	0	Rev Code Bit 1	Revision Code Bit 1
4	0	Rev Code Bit 0	Revision Code Bit 0
3	1	Vendor ID bit 3	Vendor ID Bit 3
2	0	Vendor ID bit 2	Vendor ID Bit 2
1	0	Vendor ID bit 1	Vendor ID Bit 1
0	0	Vendor ID bit 0	Vendor ID Bit 0

Byte 8: Control Register 8

Bit	@Pup	Name	Description
7	1	Device_ID3	0000 = CK505 Yellow Cover Device, 56-pin TSSOP
6	0	Device_ID2	0001 = CK505 Yellow Cover Device, 64-pin TSSOP 0010 = CK505 Yellow Cover Device, 48-pin QFN (Reserved)
5	1	Device_ID1	0011 = CK505 Yellow Cover Device, 56-pin QFN (Reserved)
4	0	Device_ID0	0100 = CK505 Yellow Cover Device, 64-pin QFN 0101 = CK505 Yellow Cover Device, 72-pin QFN (Reserved) 0110 = CK505 Yellow Cover Device, 48-pin SSOP (Reserved) 0111 = CK505 Yellow Cover Device, 56-pin SSOP (Reserved) 1000 = Reserved 1001 = Reserevd 1010 = CK505 Mobile 1011 = Reserved 1100 = Reserved 1101 = Reserved 1110 = Reserved 1111 = Reserved
3	0	Reserved	Reserved
2	0	Reserved	Reserved
1	0	Reserved	Reserved
0	0	Reserved	Reserved

Byte 9: Control Register 9

Bit	@Pup	Name	Description
-----	------	------	-------------



Byte 9: Control Register 9

7	0	PCIF_0_with PCI_STOP#	Allows control of PCIF_0 with assertion of PCI_STOP# 0 = Free running PCIF, 1 = Stopped with PCI_STOP#
6	HW	TME_STRAP	Trusted mode enable strap status 0 = Normal, 1 = No overclocking
5	1	REF drive strength	REF drive strength bit 1 (DSC 1) 0 = Low, 1 = High See byte 13 for full-range setting
4	0	TEST_MODE_SEL	Mode select either REF/N or tri-state 0 = All output tri-state, 1 = All output REF/N
3	0	TEST_MODE_ENTRY	Allow entry into test mode 0 = Normal operation, 1 = Enter test mode
2	1	12C_VOUT<2>	I2C_VOUT[2,1,0] 000 = 0.3V 001 = 0.4V 010 = 0.5V 011 = 0.6V 100 = 0.7V 101 = 0.8V (default) 110 = 0.9V 111 = 1.0V
1	0	12C_VOUT<1>	
0	1	12C_VOUT<0>	

Byte 10: Control Register 10

Bit	@Pup	Name	Description
7	HW	GCLK_SEL latch	Readback of GCLK_SEL latch 0 = SRC1, 1 = LCD_100M
6	0	PLL3_EN	PLL3 power down 0 = Power down, 1 = Power up When GCLK_SEL=0, this bit is 0. When GCLK_SEL=1, this bit is 1.
5	1	PLL2_EN	PLL2 power down 0 = Power down, 1 = Power up
4	1	SRC_DIV_EN	SRC divider disable 0 = Disabled, 1 = Enabled
3	1	PCI_DIV_EN	PCI divider disable 0 = Disabled, 1 = Enabled
2	1	CPU_DIV_EN	CPU divider disable 0 = Disabled, 1 = Enabled
1	1	CPU1 Stop Enable	Enable CPU_STOP# control of CPU1 0 = Free running, 1= Stoppable
0	1	CPU0 Stop Enable	Enable CPU_STOP# control of CPU0 0 = Free running, 1= Stoppable

Byte 11: Control Register 11

Bit	@Pup	Name	Description
7	0	Reserved	Reserved
6	0	Reserved	Reserved
5	0	Reserved	Reserved
4	0	Reserved	Reserved
3	0	Reserved	Reserved
2	0	Reserved	Reserved
1	0	Reserved	Reserved

Byte 11: Control Register 11 (continued)

0	1	CPU[T/C]2	Allow control of CPU2 with assertion of CPU_STOP# 0 = Free running, 1 = Stopped with CPU_STOP#
---	---	-----------	---

Byte 12: Byte Count

Bit	@Pup	Name	Description
7	0	Reserved	Reserved
6	0	Reserved	Reserved
5	0	BC5	Byte count
4	0	BC4	Byte count
3	1	BC3	Byte count
2	1	BC2	Byte count
1	0	BC1	Byte count
0	1	BC0	Byte count

Byte 13: Control Register 13

Bit	@Pup	Name	Description																																										
7	0	PCI/PCIF drive strength control bit 2	Drive Strength Control table (DSC[2:0])																																										
6	1	PCI/PCIF drive strength control bit 1																																											
5	1	PCI/PCIF drive strength control bit 0																																											
4	0	USB drive strength control bit 2																																											
3	1	USB drive strength control bit 1																																											
2	0	USB drive strength control bit 0																																											
1	0	REF drive strength control bit 2																																											
0	0	REF drive strength control bit 0																																											
				<table border="1"> <thead> <tr> <th></th> <th>DSC_2</th> <th>DSC_1</th> <th>DSC_0</th> <th>Buffer Strength</th> </tr> </thead> <tbody> <tr> <td></td> <td>1</td> <td>1</td> <td>1</td> <td>Strongest</td> </tr> <tr> <td></td> <td>1</td> <td>1</td> <td>0</td> <td rowspan="4">↑</td> </tr> <tr> <td></td> <td>1</td> <td>0</td> <td>1</td> </tr> <tr> <td></td> <td>1</td> <td>0</td> <td>0</td> </tr> <tr> <td>Default PCI</td> <td>0</td> <td>1</td> <td>1</td> </tr> <tr> <td>Default REF/USB</td> <td>0</td> <td>1</td> <td>0</td> </tr> <tr> <td></td> <td>0</td> <td>0</td> <td>1</td> <td rowspan="2">↓</td> </tr> <tr> <td></td> <td>0</td> <td>0</td> <td>0</td> <td>Weakest</td> </tr> </tbody> </table>		DSC_2	DSC_1	DSC_0	Buffer Strength		1	1	1	Strongest		1	1	0	↑		1	0	1		1	0	0	Default PCI	0	1	1	Default REF/USB	0	1	0		0	0	1	↓		0	0	0	Weakest
	DSC_2	DSC_1		DSC_0	Buffer Strength																																								
	1	1	1	Strongest																																									
	1	1	0	↑																																									
	1	0	1																																										
	1	0	0																																										
Default PCI	0	1	1																																										
Default REF/USB	0	1	0																																										
	0	0	1	↓																																									
	0	0	0		Weakest																																								

Byte 14: Control Register 14

Bit	@Pup	Name	Description
7	0	Reserevd	Reserved
6	0	Reserevd	Reserved
5	0	PLL1 spread percentage	Select percentage of spread for PLL1 0 = 0.5%, 1=1%
4	0	Reserevd	Reserved
3	0	Reserevd	Reserved
2	0	Reserevd	Reserved
1	0	Reserevd	Reserved

Byte 14: Control Register 14

Bit	@Pup	Name	Description
0	1	SW_PCI	<p>SW PCI_STP# Function</p> <p>0 = SW PCI_STP assert, 1 = SW PCI_STP deassert</p> <p>When this bit is set to 0, all STOPPABLE PCI, PCIF and SRC outputs are stopped in a synchronous manner with no short pulses.</p> <p>When this bit is set to 1, all STOPPED PCI, PCIF and SRC outputs are resumed in a synchronous manner with no short pulses.</p>

Table 5. Crystal Recommendations

Frequency (Fund)	Cut	Loading	Load Cap	Drive (max.)	Shunt Cap (max.)	Motional (max.)	Tolerance (max.)	Stability (max.)	Aging (max.)
14.31818 MHz	AT	Parallel	20 pF	0.1 mW	5 pF	0.016 pF	35 ppm	30 ppm	5 ppm

The SL28540 requires a Parallel Resonance Crystal. Substituting a series resonance crystal causes the SL28540 to operate at the wrong frequency and violates the ppm specification. For most applications there is a 300-ppm frequency shift between series and parallel crystals due to incorrect loading

Crystal Loading

Crystal loading plays a critical role in achieving low ppm performance. To realize low ppm performance, use the total capacitance the crystal sees to calculate the appropriate capacitive loading (CL).

Figure 1 shows a typical crystal configuration using the two trim capacitors. It is important that the trim capacitors are in series with the crystal. It is not true that load capacitors are in parallel with the crystal and are approximately equal to the load capacitance of the crystal.

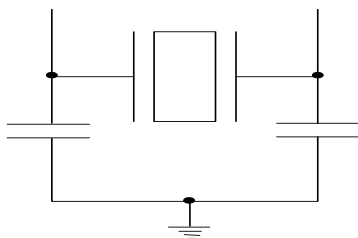

Figure 1. Crystal Capacitive Clarification

Calculating Load Capacitors

In addition to the standard external trim capacitors, consider the trace capacitance and pin capacitance to calculate the crystal loading correctly. Again, the capacitance on each side is in series with the crystal. The total capacitance on both side is twice the specified crystal load capacitance (CL). Trim capacitors are calculated to provide equal capacitive loading on both sides.

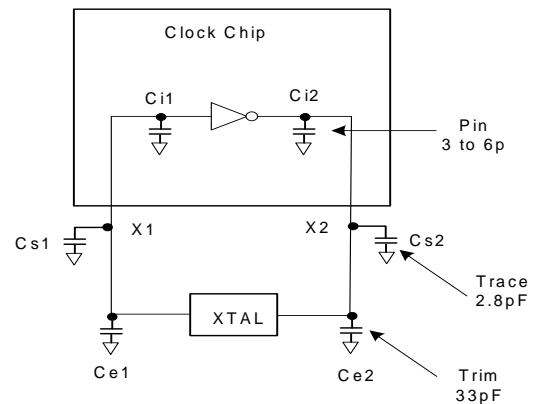

Figure 2. Crystal Loading Example

Use the following formulas to calculate the trim capacitor values for Ce1 and Ce2.

Load Capacitance (each side)

$$C_e = 2 * CL - (C_s + C_i)$$

Total Capacitance (as seen by the crystal)

$$CL_e = \frac{1}{\left(\frac{1}{C_{e1} + C_{s1} + C_{i1}} + \frac{1}{C_{e2} + C_{s2} + C_{i2}} \right)}$$

- CL.....Crystal load capacitance
- CLe..... Actual loading seen by crystal using standard value trim capacitors
- Ce..... External trim capacitors
- Cs..... Stray capacitance (terraced)
- Ci Internal capacitance (lead frame, bond wires, etc.)

PD_RESTORE

If a '0' is set for Byte 0 bit 0 then, upon assertion of PWRDWN# LOW, the SL28540 initiates a full reset. The result of this is that the clock chip emulates a cold power on start and goes to the "Latches Open" state. If the PD_RESTORE bit is set to a '1' then the configuration is stored upon PWRDWN# asserted LOW. Note that if the iAMT bit, Byte 0 bit 3, is set to a '1' then the PD_RESTORE bit must be ignored. In other words, in Intel iAMT mode, PWRDWN# reset is not allowed.

PWRDWN# (Power down) Clarification

The CKPWRGD/PWRDWN# pin is a dual-function pin. During initial power up, the pin functions as CKPWRGD. Once CKPWRGD has been sampled HIGH by the clock chip, the pin assumes PD# functionality. The PD# pin is an asynchronous active LOW input used to shut off all clocks cleanly before shutting off power to the device. This signal is synchronized internally to the device before powering down the clock synthesizer. PD# is also an asynchronous input for powering up the system. When PD# is asserted LOW, clocks are driven to a LOW value and held before turning off the VCOs and the crystal oscillator.

PWRDWN# (Power down) Assertion

When PD is sampled HIGH by two consecutive rising edges of CPUC, all single-ended outputs will be held LOW on their next HIGH-to-LOW transition and differential clocks must held LOW. When PD mode is desired as the initial power on state, PD must be asserted HIGH in less than 10 μ s after asserting CKPWRGD.

PWRDWN# Deassertion

The power up latency is less than 1.8 ms. This is the time from the deassertion of the PD# pin or the ramping of the power supply until the time that stable clocks are generated from the clock chip. All differential outputs stopped in a three-state condition, resulting from power down are driven high in less than 300 μ s of PD# deassertion to a voltage greater than 200 mV. After the clock chip's internal PLL is powered up and locked, all outputs are enabled within a few clock cycles of each clock. *Figure 4* is an example showing the relationship of clocks coming up.

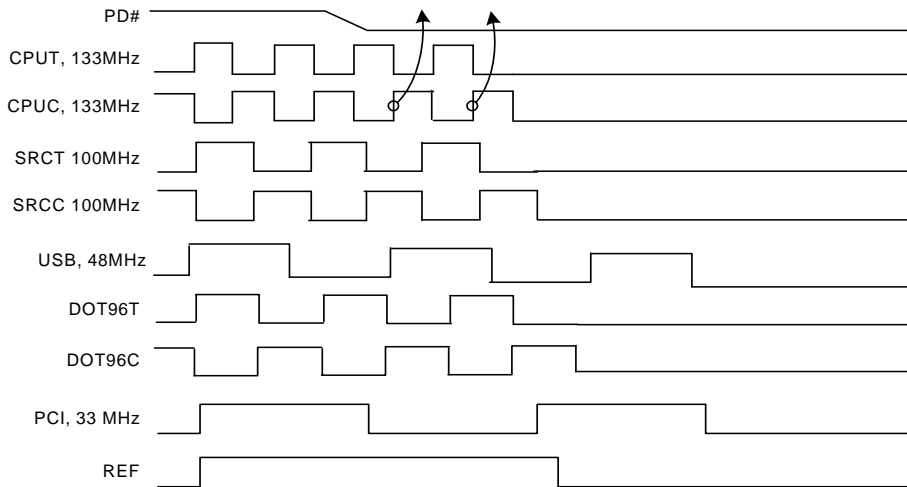

Figure 3. Power down Assertion Timing Waveform

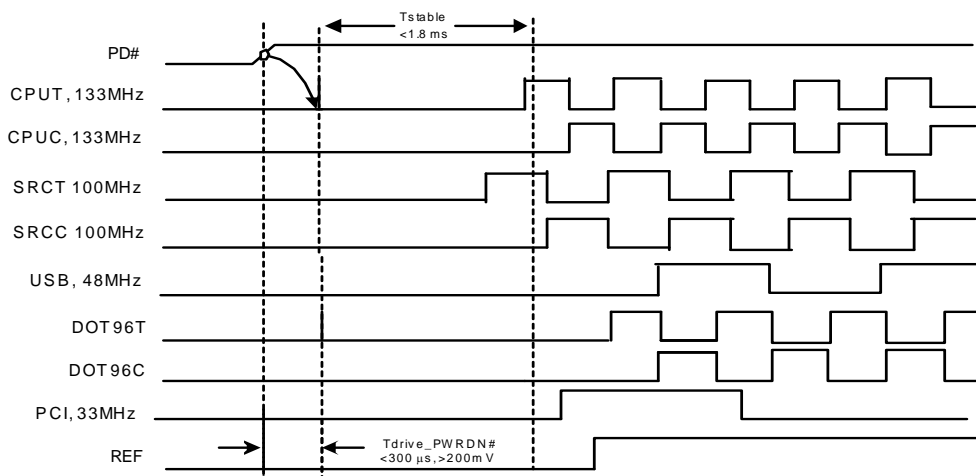

Figure 4. Power down Deassertion Timing Waveform

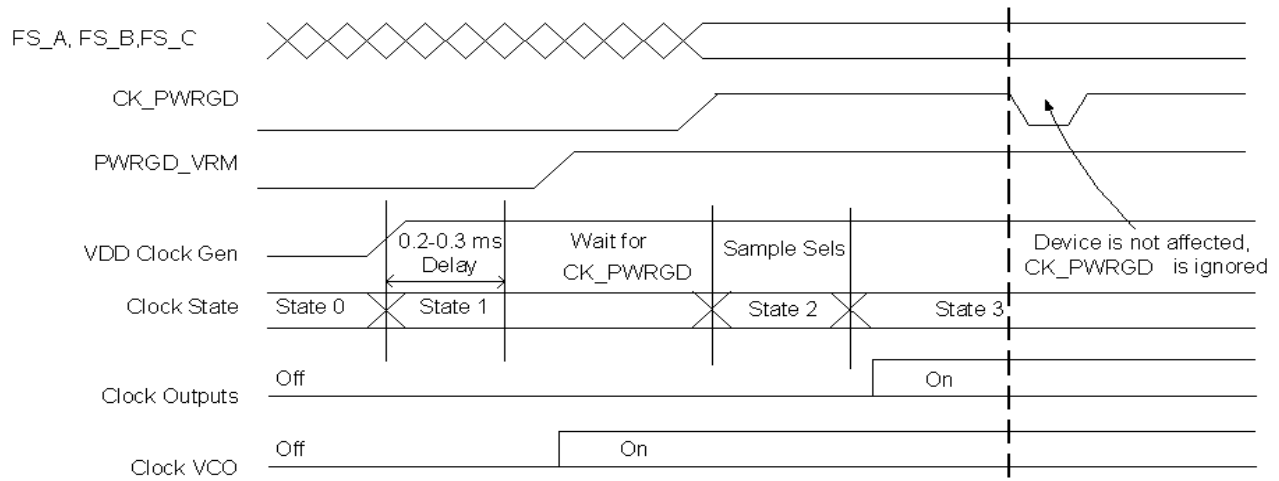

Figure 5. CKPWRGD Timing Diagram

CPU_STP# Assertion

The CPU_STP# signal is an active LOW input used for synchronous stopping and starting the CPU output clocks while the rest of the clock generator continues to function. When the CPU_STP# pin is asserted, all CPU outputs that are set with the SMBus configuration to be stoppable are stopped within two to six CPU clock periods after sampled by two rising edges of the internal CPUC clock. The final states of the stopped CPU signals are CPUT = HIGH and CPUC = LOW.

CPU_STP# Deassertion

The deassertion of the CPU_STP# signal causes all stopped CPU outputs to resume normal operation in a synchronous manner. No short or stretched clock pulses are produced when the clock resumes. The maximum latency from the deassertion to active outputs is no more than two CPU clock cycles.

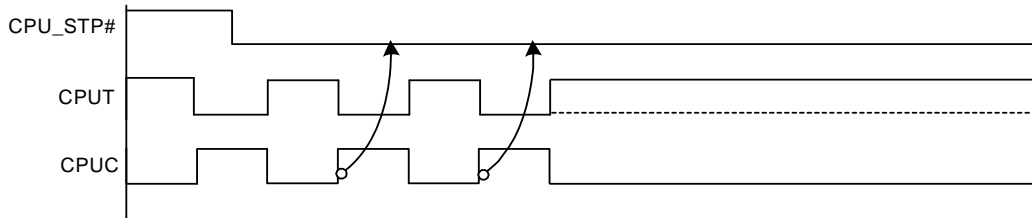

Figure 6. CPU_STP# Assertion Waveform

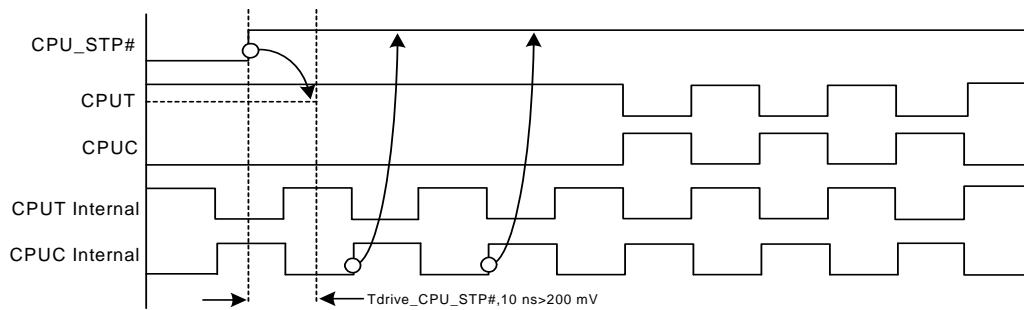

Figure 7. CPU_STP# Deassertion Waveform

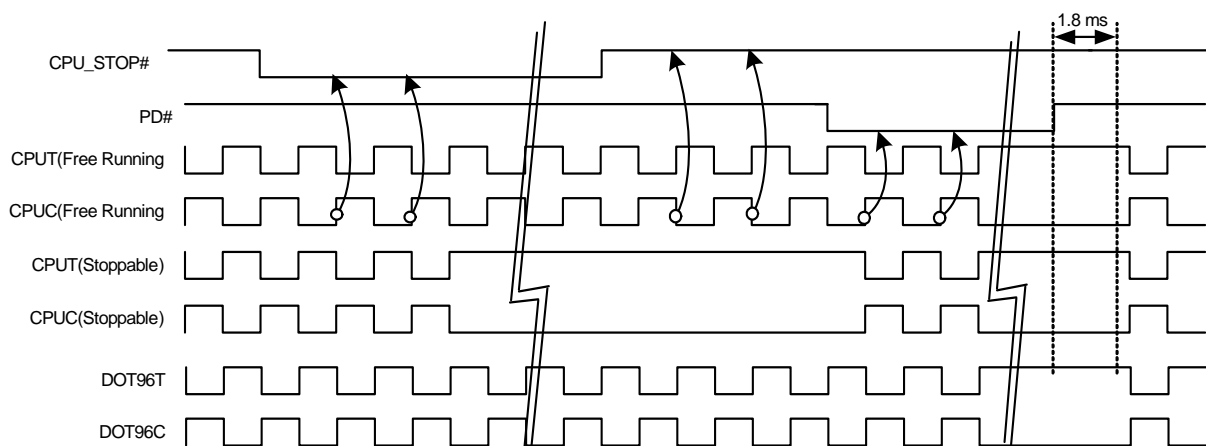

Figure 8. CPU_STP# = Driven, CPU_PD = Driven, DOT_PD = Driven

PCI_STP# Assertion

The PCI_STP# signal is an active LOW input used for synchronously stopping and starting the PCI outputs while the rest of the clock generator continues to function. The set-up time for capturing PCI_STP# going LOW is 10 ns (t_{SU}). (See Figure 9.) The PCIF clocks are affected by this pin if their corresponding control bit in the SMBus register is set to allow them to be free running.

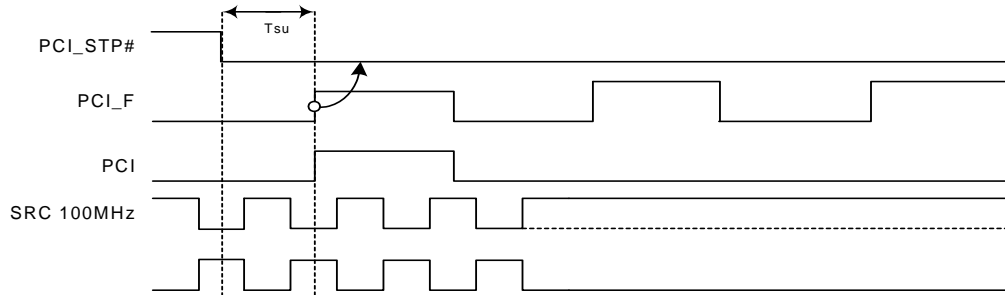

Figure 9. PCI_STP# Assertion Waveform

PCI_STP# Deassertion

The deassertion of the PCI_STP# signal causes all PCI and stoppable PCIF clocks to resume running in a synchronous manner within two PCI clock periods, after PCI_STP# transitions to a HIGH level.

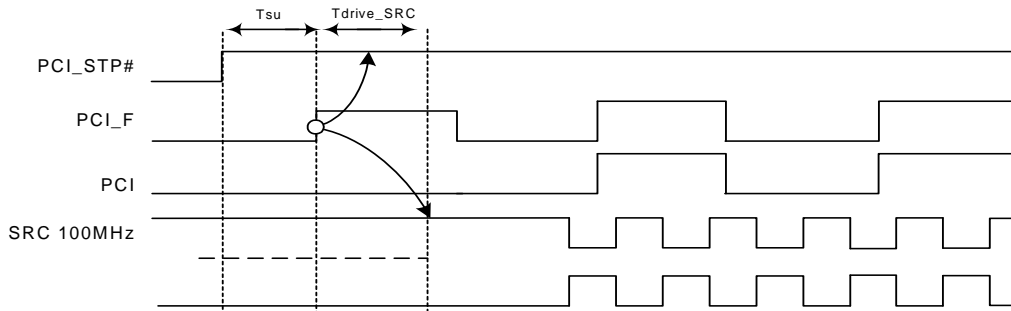

Figure 10. PCI_STP# Deassertion Waveform

Table 6. Output Driver Status during PCI-STOP# and CPU-STOP#

		PCI_STOP# Asserted	CPU_STOP# Asserted	SMBus OE Disabled
Single-ended Clocks	Stoppable	Driven low	Running	Driven low
	Non stoppable	Running	Running	
Differential Clocks	Stoppable	Clock driven high	Clock driven high	Clock driven Low or 20K pulldown
		Clock# driven low	Clock# driven low	
	Non stoppable	Running	Running	

Table 7. Output Driver Status

	All Single-ended Clocks		All Differential Clocks except CPU1		CPU1	
	w/o Strap	w/ Strap	Clock	Clock#	Clock	Clock#
Latches Open State	Low	Hi-Z	Low or 20K pulldown	Low	Low or 20K pulldown	Low
Powerdown	Low	Hi-Z	Low or 20K pulldown	Low	Low or 20K pulldown	Low

Table 8. PLL3/SE Configuration Table

GCLK_SEL	B1b4	B1b3	B1b2	B1b1	Pin 23 (MHz)	Pin 24 (MHz)	Spread (%)	Comment
0	0	0	0	0	PLL3 Disabled			
0	0	0	0	1	100	100	0.5	SRC1 from SRC_Main
1	0	0	1	0	100	100	0.5	LCD_100 from PLL3
1	0	0	1	1	100	100	1	LCD_100 from PLL3
1	0	1	0	0	100	100	1.5	LCD_100 from PLL3
1	0	1	0	1	100	100	2	LCD_100 from PLL3

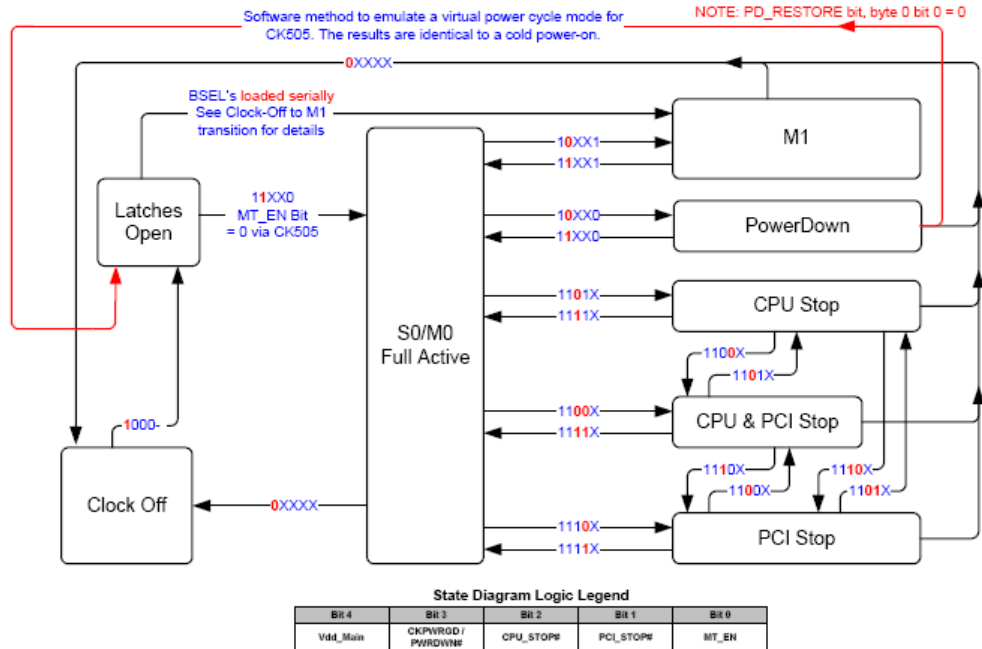

Figure 11. Clock Generator Power up/Run State Diagram

Absolute Maximum Conditions

Parameter	Description	Condition	Min.	Max.	Unit
V _{DD}	Core Supply Voltage			4.6	V
V _{DD_A}	Analog Supply Voltage			4.6	V
V _{DD_IO}	IO Supply Voltage			3.8	V
V _{IN}	Input Voltage	Relative to V _{SS}	-0.5	4.6	V
T _S	Temperature, Storage	Non-functional	-65	150	°C
T _A	Temperature, Operating Ambient	Functional	0	85	°C
T _J	Temperature, Junction	Functional	-	150	°C
∅ _{JC}	Dissipation, Junction to Case	Mil-STD-883E Method 1012.1	-	20	°C/W
∅ _{JA}	Dissipation, Junction to Ambient	JEDEC (JESD 51)	-	60	°C/W
ESD _{HBM}	ESD Protection (Human Body Model)	MIL-STD-883, Method 3015	2000	-	V
UL-94	Flammability Rating	At 1/8 in.	V-0		
MSL	Moisture Sensitivity Level		1		

Multiple Supplies: The Voltage on any input or I/O pin cannot exceed the power pin during power-up. Power supply sequencing is NOT required.

DC Electrical Specifications

Parameter	Description	Condition	Min.	Max.	Unit
V _{DD core}	3.3V Operating Voltage	3.3 ± 5%	3.135	3.465	V
V _{DD IO}	3.3V Operating Voltage	3.3 ± 5%,	3.135	3.465	V
	1.05V Operating Voltage	1.05V ± 5%	0.9975	1.1025	V
V _{IH}	3.3V Input High Voltage (SE)		2.0	V _{DD} + 0.3	V
V _{IL}	3.3V Input Low Voltage (SE)		V _{SS} - 0.3	0.8	V
V _{IHI2C}	Input High Voltage	SDATA, SCLK	2.2	-	V
V _{ILI2C}	Input Low Voltage	SDATA, SCLK	-	1.0	V
V _{IH_FS}	FS_[A,B] Input High Voltage		0.7	V _{DD} + 0.3	V
V _{IL_FS}	FS_[A,B] Input Low Voltage		V _{SS} - 0.3	0.35	V
V _{IHFS_C_TEST}	FS_C Input High Voltage		2.0	V _{DD} + 0.3	V
V _{IMFS_C_NORMAL}	FS_C Input Middle Voltage		0.7	1.5	V
V _{ILFS_C_NORMAL}	FS_C Input Low Voltage		V _{SS} - 0.3	0.35	V
I _{IH}	Input High Leakage Current	Except internal pull-down resistors, 0 < V _{IN} < V _{DD}	-	5	μA
I _{IL}	Input Low Leakage Current	Except internal pull-up resistors, 0 < V _{IN} < V _{DD}	-5	-	μA
V _{OH}	3.3V Output High Voltage (SE)	I _{OH} = -1 mA	2.4	-	V
V _{OL}	3.3V Output Low Voltage (SE)	I _{OL} = 1 mA	-	0.4	V
I _{OZ}	High-impedance Output Current		-10	10	μA
C _{IN}	Input Pin Capacitance		1.5	5	pF
C _{OUT}	Output Pin Capacitance			6	pF
L _{IN}	Pin Inductance		-	7	nH
V _{XIH}	Xin High Voltage		0.7V _{DD}	V _{DD}	V
V _{XIL}	Xin Low Voltage		0	0.3V _{DD}	V
I _{DD3.3V}	Dynamic Supply Current		-	100 ¹	mA
I _{DD_IO}	Dynamic IO Supply Current			40	mA
I _{DD_PWRDWN}	Power down supply current			1	mA

1. All clock outputs are driving test case lump loads



AC Electrical Specifications

Parameter	Description	Condition	Min.	Max.	Unit
Crystal					
T _{DC}	XIN Duty Cycle	The device operates reliably with input duty cycles up to 30/70 but the REF clock duty cycle will not be within specification	47.5	52.5	%
T _{PERIOD}	XIN Period	When XIN is driven from an external clock source	69.841	71.0	ns
T _R /T _F	XIN Rise and Fall Times	Measured between 0.3V _{DD} and 0.7V _{DD}	–	10.0	ns
T _{CCJ}	XIN Cycle to Cycle Jitter	As an average over 1-μs duration	–	500	ps
CPU at 0.8V					
T _{DC}	CPUT and CPUC Duty Cycle	Measured at 0V differential at 0.1s	45	55	%
T _{PERIOD}	100 MHz CPUT and CPUC Period	Measured at 0V differential at 0.1s	9.99900	10.0010	ns
T _{PERIOD}	133 MHz CPUT and CPUC Period	Measured at 0V differential at 0.1s	7.49925	7.50075	ns
T _{PERIOD}	166 MHz CPUT and CPUC Period	Measured at 0V differential at 0.1s	5.99940	6.00060	ns
T _{PERIOD}	200 MHz CPUT and CPUC Period	Measured at 0V differential at 0.1s	4.99950	5.00050	ns
T _{PERIODSS}	100 MHz CPUT and CPUC Period, SSC	Measured at 0V differential at 0.1s	10.02406	10.0261	ns
T _{PERIODSS}	133 MHz CPUT and CPUC Period, SSC	Measured at 0V differential at 0.1s	7.51805	7.51955	ns
T _{PERIODSS}	166 MHz CPUT and CPUC Period, SSC	Measured at 0V differential at 0.1s	6.01444	6.01564	ns
T _{PERIODSS}	200 MHz CPUT and CPUC Period, SSC	Measured at 0V differential at 0.1s	5.01203	5.01303	ns
T _{PERIODAbs}	100 MHz CPUT and CPUC Absolute period	Measured at 0V differential at 1 clock	9.91400	10.0860	ns
T _{PERIODAbs}	133 MHz CPUT and CPUC Absolute period	Measured at 0V differential at 1 clock	7.41425	7.58575	ns
T _{PERIODAbs}	166 MHz CPUT and CPUC Absolute period	Measured at 0V differential @ 1 clock	5.91440	6.08560	ns
T _{PERIODAbs}	200 MHz CPUT and CPUC Absolute period	Measured at 0V differential @ 1 clock	4.91450	5.08550	ns
T _{PERIODSSAbs}	100 MHz CPUT and CPUC Absolute period, SSC	Measured at 0V differential @ 1 clock	9.93906	10.1362	ns
T _{PERIODSSAbs}	133 MHz CPUT and CPUC Absolute period, SSC	Measured at 0V differential @ 1 clock	7.43305	7.62340	ns
T _{PERIODSSAbs}	166 MHz CPUT and CPUC Absolute period, SSC	Measured at 0V differential @ 1 clock	5.92944	6.11572	ns
T _{PERIODSSAbs}	200 MHz CPUT and CPUC Absolute period, SSC	Measured at 0V differential @ 1 clock	4.92703	5.11060	ns
T _{CCJ}	CPUT/C Cycle to Cycle Jitter	Measured at 0V differential	–	85	ps
T _{CCJ2}	CPU2_ITP Cycle to Cycle Jitter	Measured at 0V differential	–	125	ps
L _{ACC}	Long-term Accuracy	Measured at 0V differential	–	100	ppm
T _{SKEW}	CPU1 to CPU0 Clock Skew	Measured at 0V differential	–	100	ps
T _{SKEW2}	CPU2_ITP to CPU0 Clock Skew	Measured at 0V differential	–	150	ps
T _R /T _F	CPU Rising and Falling slew rate	Measured differentially from ±150 mV	2.5	8	V/ns
T _{RFM}	Rise/Fall Matching	Measured single-endedly from ±75 mV	–	20	%
V _{HIGH}	Voltage High			1.15	V
V _{LOW}	Voltage Low		–0.3	–	V
V _{OX}	Crossing Point Voltage at 0.7V Swing		300	550	mV
SRC at 0.8V					
T _{DC}	SRCT and SRCC Duty Cycle	Measured at 0V differential	45	55	%
T _{PERIOD}	100 MHz SRC Period	Measured at 0V differential @ 0.1s	9.99900	10.0010	ns

AC Electrical Specifications (continued)

Parameter	Description	Condition	Min.	Max.	Unit
T _{PERIODSS}	100 MHz SRC Period with Spread enabled	Measured at 0V differential @ 0.1s	10.02406	10.0261	ns
T _{PERIODAbs}	100 MHz SRC Absolute Period	Measured at 0V differential @ 1 clock	9.8740	10.1260	ns
T _{PERIODSSAbs}	100 MHz SRC Absolute Period with Spread enabled	Measured at 0V differential @ 1 clock	9.89906	10.1762	ns
T _{CCJ}	SRC Cycle to Cycle Jitter	Measured at 0V differential	–	125	ps
L _{ACC}	SRC Long Term Accuracy	Measured at 0V differential	–	100	ppm
T _R / T _F	SRC Rising and Falling slew rate	Measured differentially from ±150 mV	2.5	8	V/ns
T _{RFM}	Rise/Fall Matching	Measured single-endedly from ±75 mV	–	20	%
V _{HIGH}	Voltage High			1.15	V
V _{LOW}	Voltage Low		–0.3	–	V
V _{OX}	Crossing Point Voltage at 0.7V Swing		300	550	mV
DOT96 at 0.8V					
T _{DC}	DOT96T and DOT96C Duty Cycle	Measured at 0V differential	45	55	%
T _{PERIOD}	DOT96T and DOT96C Period	Measured at 0V differential at 0.1s	10.4156	10.4177	ns
T _{PERIODAbs}	DOT96T and DOT96C Absolute Period	Measured at 0V differential at 0.1s	10.1656	10.6677	ns
T _{CCJ}	DOT96 Cycle to Cycle Jitter	Measured at 0V differential at 1 clock	–	250	ps
L _{ACC}	DOT96 Long Term Accuracy	Measured at 0V differential at 1 clock	–	100	ppm
T _R / T _F	DOT96 Rising and Falling slew rate	Measured differentially from ±150 mV	2.5	8	V/ns
T _{RFM}	Rise/Fall Matching	Measured single-endedly from ±75 mV	–	20	%
V _{HIGH}	Voltage High			1.15	V
V _{LOW}	Voltage Low		–0.3	–	V
V _{OX}	Crossing Point Voltage at 0.7V Swing		300	550	mV
LCD_100_SSC at 0.8V					
T _{DC}	LCD_100 Duty Cycle	Measured at 0V differential	45	55	%
T _{PERIOD}	LCD_100 Period	Measured at 0V differential at 0.1s	9.99900	10.0010	ns
T _{PERIODSS}	LCD_100 Period with -0.5% Spread	Measured at 0V differential at 0.1s	10.02406	10.0261	ns
T _{PERIODAbs}	LCD_100 Absolute Period	Measured at 0V differential at 1 clock	9.874	10.0860	ns
T _{PERIODSSAbs}	LCD_100 Absolute Period, SSC	Measured at 0V differential @ 1 clock	9.89906	10.1762	ns
T _{CCJ}	LCD_100 Cycle to Cycle Jitter	Measured at 0V differential	–	250	ps
L _{ACC}	LCD_100 Long Term Accuracy	Measured at 0V differential	–	100	ppm
T _R / T _F	LCD_100 Rising and Falling slew rate	Measured differentially from ±150 mV	2.5	8	V/ns
T _{RFM}	Rise/Fall Matching	Measured single-endedly from ±75 mV	–	20	%
V _{HIGH}	Voltage High			1.15	V
V _{LOW}	Voltage Low		–0.3	–	V
V _{OX}	Crossing Point Voltage at 0.7V Swing		300	550	mV
PCI/PCIF at 3.3V					
T _{DC}	PCI Duty Cycle	Measurement at 1.5V	45	55	%
T _{PERIOD}	Spread Disabled PCIF/PCI Period	Measurement at 1.5V	29.99100	30.00900	ns
T _{PERIODSS}	Spread Enabled PCIF/PCI Period	Measurement at 1.5V	29.99100	30.15980	ns
T _{PERIODAbs}	Spread Disabled PCIF/PCI Period	Measurement at 1.5V	29.49100	30.50900	ns
T _{PERIODSSAbs}	Spread Enabled PCIF/PCI Period	Measurement at 1.5V	29.49100	30.65980	ns
T _{HIGH}	Spread enabled PCIF and PCI high time	Measurement at 2.0V	12		ns
T _{LOW}	Spread enabled PCIF and PCI low time	Measurement at 0.8V	12		ns

AC Electrical Specifications (continued)

Parameter	Description	Condition	Min.	Max.	Unit
T_R / T_F	PCIF/PCI rising and falling Edge Rate	Measured between 0.8V and 2.0V	1.0	4.0	V/ns
T_{SKEW}	Any PCI clock to Any PCI clock Skew	Measurement at 1.5V	–	1000	ps
T_{CCJ}	PCIF and PCI Cycle to Cycle Jitter	Measurement at 1.5V	–	500	ps
L_{ACC}	PCIF/PCI Long Term Accuracy	Measurement at 1.5V	–	300	ppm
48_M at 3.3V					
T_{DC}	Duty Cycle	Measurement at 1.5V	45	55	%
T_{PERIOD}	Period	Measurement at 1.5V	20.83125	20.83542	ns
$T_{PERIODAbs}$	Absolute Period	Measurement at 1.5V	20.48125	21.18542	ns
T_{HIGH}	48_M High time	Measurement at 2.0V	8.216563	11.15198	ns
T_{LOW}	48_M Low time	Measurement at 0.8V	7.694	9.836	ns
T_R / T_F	Rising and Falling Edge Rate	Measured between 0.8V and 2.0V	1.0	2.0	V/ns
T_{CCJ}	Cycle to Cycle Jitter	Measurement at 1.5V	–	350	ps
L_{ACC}	48M Long Term Accuracy	Measurement at 1.5V	–	100	ppm
REF					
T_{DC}	REF Duty Cycle	Measurement at 1.5V	45	55	%
T_{PERIOD}	REF Period	Measurement at 1.5V	69.82033	69.86224	ns
$T_{PERIODAbs}$	REF Absolute Period	Measurement at 1.5V	68.83429	70.86224	ns
T_R / T_F	REF Rising and Falling Edge Rate	Measured between 0.8V and 2.0V	1.0	4.0	V/ns
T_{SKEW}	REF Clock to REF Clock	Measurement at 1.5V	–	500	ps
T_{CCJ}	REF Cycle to Cycle Jitter	Measurement at 1.5V	–	1000	ps
L_{ACC}	Long Term Accuracy	Measurement at 1.5V	–	300	ppm
ENABLE/DISABLE and SET-UP					
T_{STABLE}	Clock Stabilization from Power-up		–	1.8	ms
T_{SS}	Stopclock Set-up Time		10.0	–	ns

Test and Measurement Set-up

For PCI Single-ended Signals and Reference

The following diagram shows the test load configurations for the single-ended PCI, USB, and REF output signals.

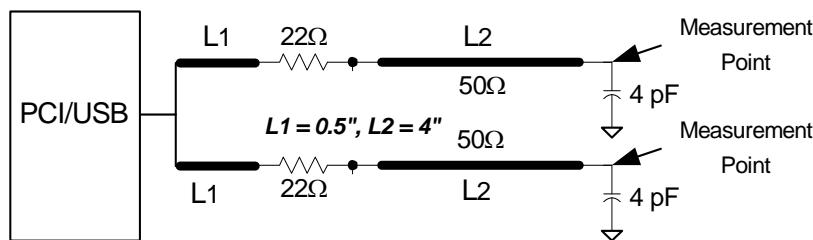

Figure 12. Single-ended PCI and USB Double Load Configuration

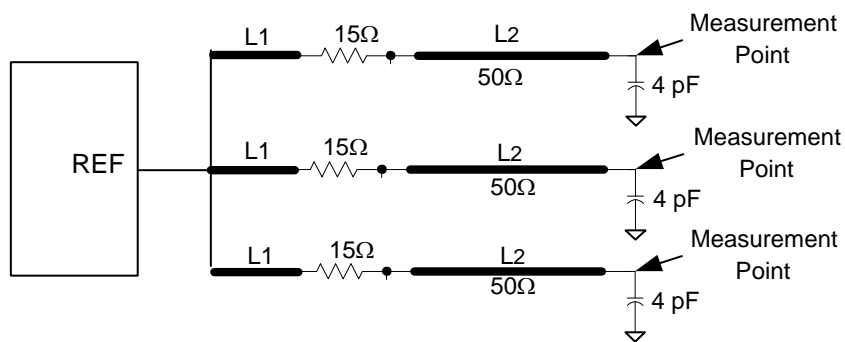

Figure 13. Single-ended REF Triple Load Configuration

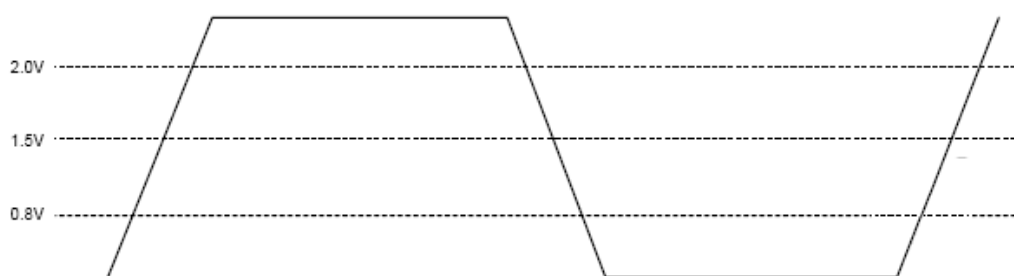

Figure 14. Single-ended Output Signals (for AC Parameters Measurement)

For CPU, SRC, and DOT96 Signals and Reference

This diagram shows the test load configuration for the differential CPU and SRC outputs

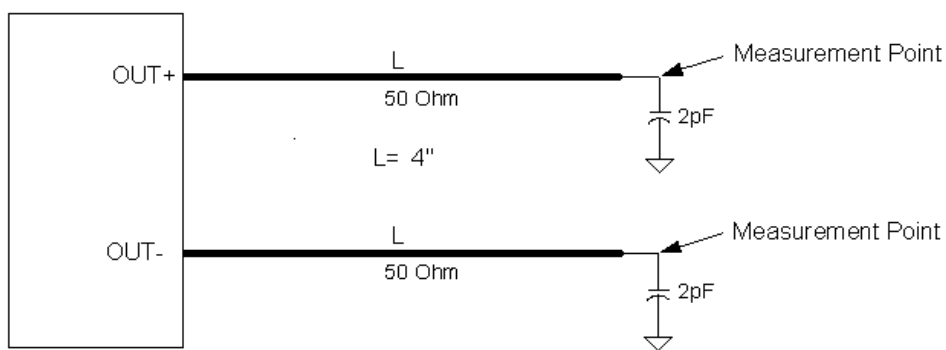

Figure 15. 0.7V Differential Load Configuration

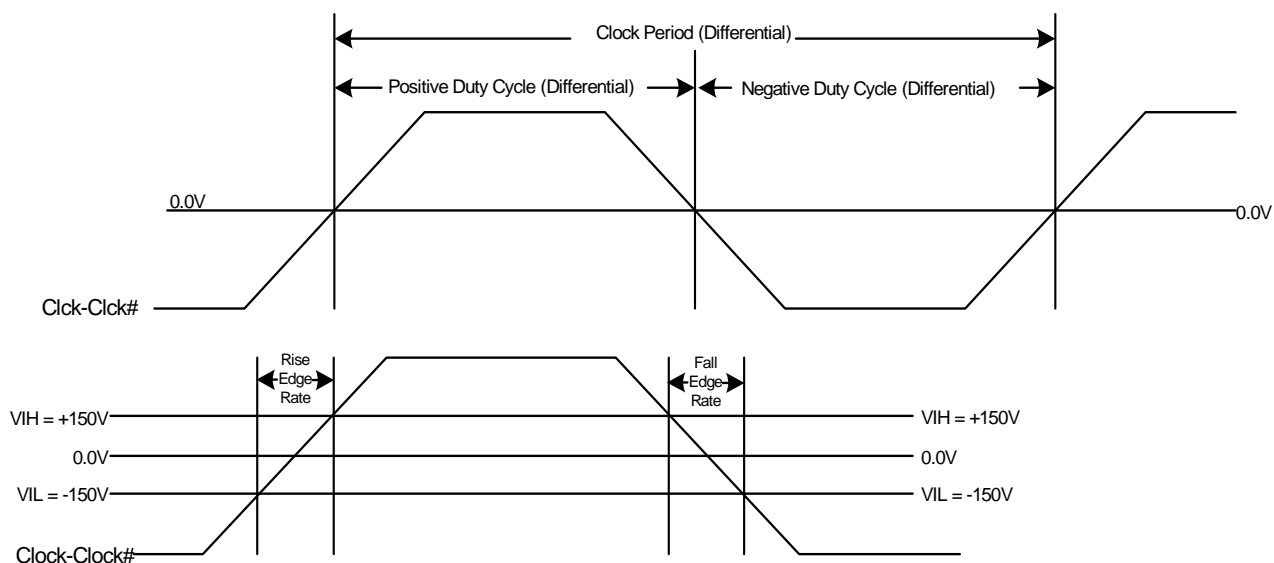

Figure 16. Differential Measurement for Differential Output Signals (for AC Parameters Measurement)

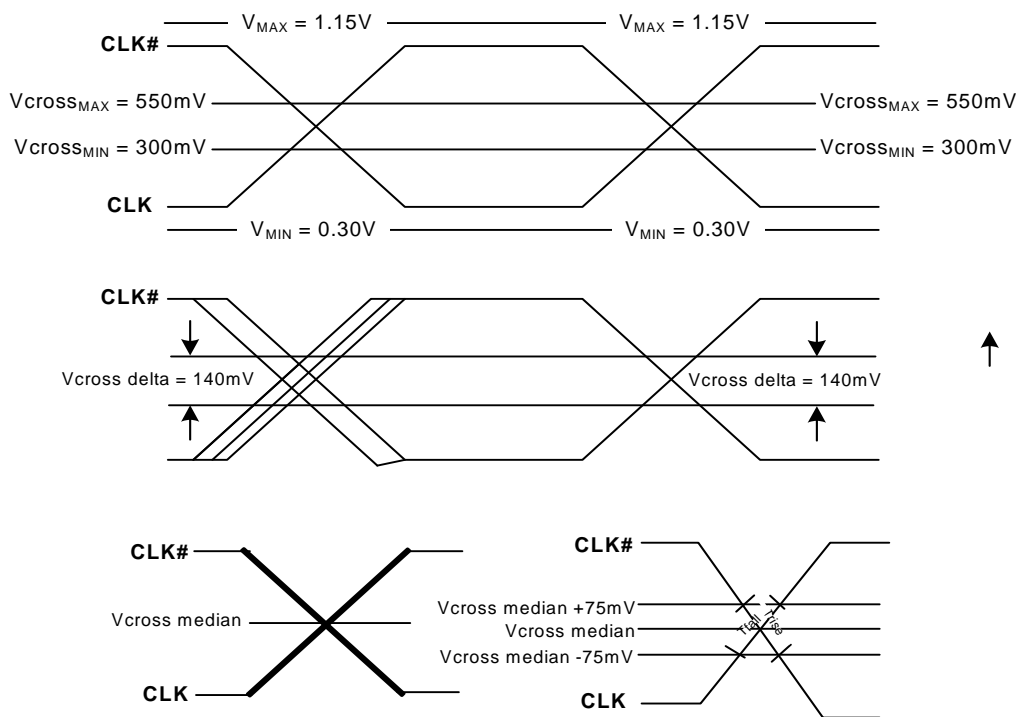

Figure 17. Single-ended Measurement for Differential Output Signals (for AC Parameters Measurement)

Ordering Information

Part Number	Package Type	Product Flow
Lead-free		
SL28540ALC	56-pin QFN	Commercial, 0° to 85°C
SL28540ALCT	56-pin QFN, Tape and Reel	Commercial, 0° to 85°C

Package Diagrams

56-Lead QFN 8x 8mm LF56A

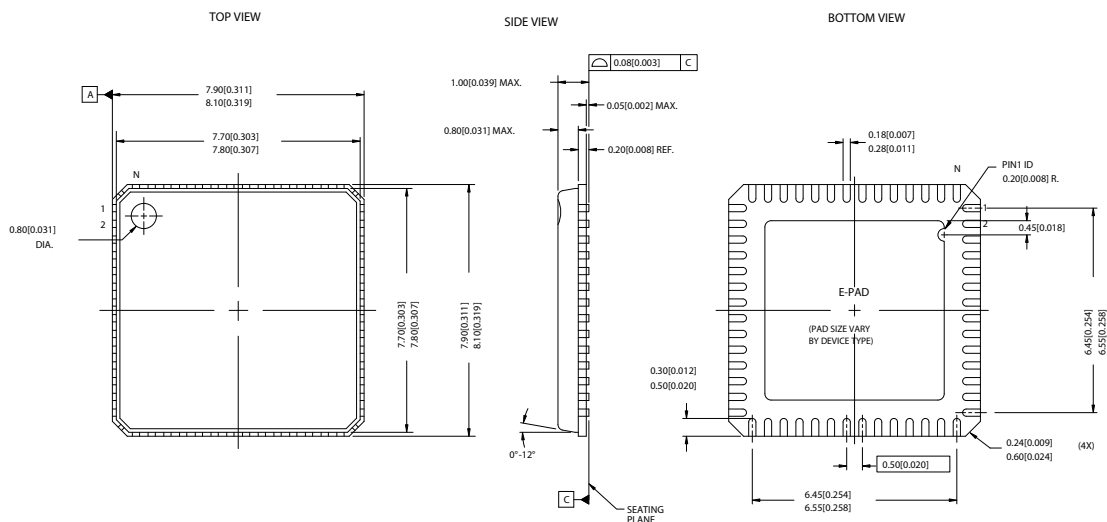





Document History Page

Document Title: SL28540 Low Power Clock Generator for Intel® Mobile Platform			
Document Number:			
REV.	Issue Date	Orig. of Change	Description of Change
1.0	03/19/2007	SLI	New data sheet
1.1	08/15/2007	SLI	Updated Features list Updated DC Electrical Specifications table Updated AC Electrical Specifications table Updated ordering information
1.2	09/15/2008	JMA	1. Added iAMT functions 2. Removed TME definition

The information in this document is believed to be accurate in all respects at the time of publication but is subject to change without notice. Silicon Laboratories assumes no responsibility for errors and omissions, and disclaims responsibility for any consequences resulting from the use of information included herein. Additionally, Silicon Laboratories assumes no responsibility for the functioning of undescribed features or parameters. Silicon Laboratories reserves the right to make changes without further notice. Silicon Laboratories makes no warranty, representation or guarantee regarding the suitability of its products for any particular purpose, nor does Silicon Laboratories assume any liability arising out of the application or use of any product or circuit, and specifically disclaims any and all liability, including without limitation consequential or incidental damages. Silicon Laboratories products are not designed, intended, or authorized for use in applications intended to support or sustain life, or for any other application in which the failure of the Silicon Laboratories product could create a situation where personal injury or death may occur. Should Buyer purchase or use Silicon Laboratories products for any such unintended or unauthorized application, Buyer shall indemnify and hold Silicon Laboratories harmless against all claims and damages.

Looking for pricing, stock, or lifecycle information?

Click below to explore more details on WIN SOURCE:

-  [View SL28540ALC on WIN SOURCE](#)
-  [Skyworks Solutions Inc. Information](#)

Optimize Your Supply Chain with WIN SOURCE Solutions

-  Global Sourcing Solution
-  Obsolete Management
-  Cost Control Management
-  Shortage Management
-  Alternative Solution
-  Excess Inventory Management