



**THE DATASHEET OF
SI5324B-C-GMR**





ANY-FREQUENCY PRECISION CLOCK MULTIPLIER/ JITTER ATTENUATOR

Features

- Generates any frequency from 2 kHz to 945 MHz and select frequencies to 1.4 GHz from an input frequency of 2 kHz to 710 MHz
- Ultra-low jitter clock outputs as low as 290 fs rms (12 kHz–20 MHz), 320 fs rms (50 kHz–80 MHz)
- Integrated loop filter with selectable loop bandwidth (4– 525 Hz)
- Meets ITU-T G.8251 and Telcordia GR-253-CORE jitter specification
- Hitless input clock switching with phase build-out
- Freerun, Digital Hold operation
- Configurable signal format per output (LVPECL, LVDS, CML, CMOS)
- Support for ITU G.709 and custom FEC ratios (255/238, 255/237, 255/236, 239/237, 66/64, 239/238, 15/14, 253/221, 255/238)
- LOL, LOS, FOS alarm outputs
- I²C or SPI programmable
- On-chip voltage regulator with high PSNR
- Single supply 1.8 ±5%, 2.5 ±10%, or 3.3 V ±10%
- Small size: 6 x 6 mm 36-lead QFN
- Pb-free, ROHS-compliant

Applications

- Broadcast video –3G/HD/SD-SDI, Genlock
- Packet Optical Transport Systems (P-OTS), MSPP
- OTN/OTU-1/2/3/4 Asynchronous Demapping (Gapped Clock)
- SONET OC-48/192/768, SDH/STM-16/64/256 line cards
- 1/2/4/8/10G Fibre Channel line cards
- GbE/10/40/100G Synchronous Ethernet (LAN/WAN)
- Data converter clocking
- Wireless base stations
- Test and measurement

Description

The Si5324 is a low-bandwidth, jitter-attenuating, precision clock multiplier for applications requiring sub 1 ps jitter performance with loop bandwidths between 4 Hz and 525 Hz. The Si5324 accepts two input clocks ranging from 2 kHz to 710 MHz and generates two output clocks ranging from 2 kHz to 945 MHz and select frequencies to 1.4 GHz. The two outputs are divided down separately from a common source. The Si5324 can also use its external reference as a clock source for frequency synthesis. The device provides virtually any frequency translation combination across this operating range. The Si5324 input clock frequency and clock multiplication ratio are programmable via an I²C or SPI interface. The Si5324 is based on Skyworks Solutions' 3rd-generation DSPLL[®] technology, which provides any-frequency synthesis and jitter attenuation in a highly integrated PLL solution that eliminates the need for external VCXO and filter components. The DSPLL loop bandwidth is digitally programmable, providing jitter performance optimization at the application level. The Si5324 is ideal for providing clock multiplication and jitter attenuation in high performance timing applications.

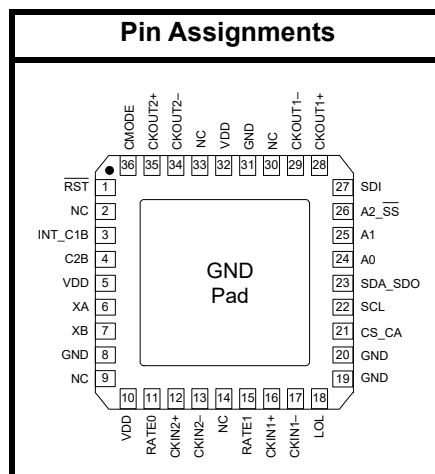
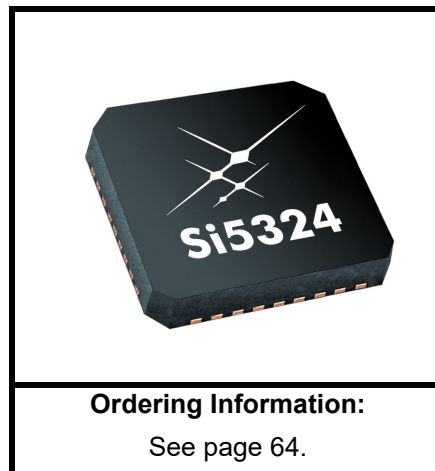

Si5324

Functional Block Diagram

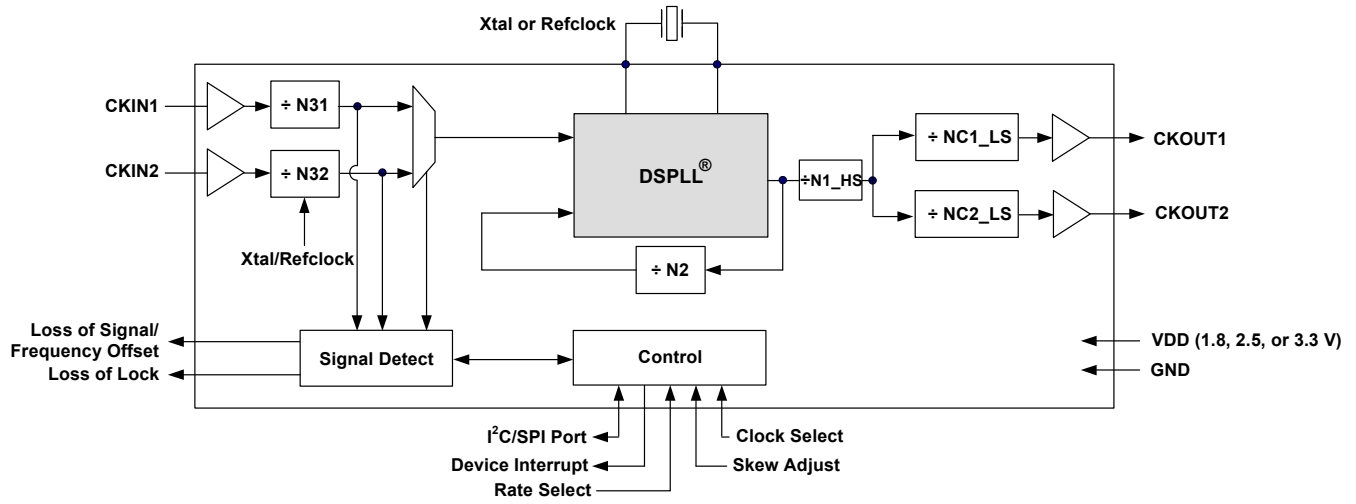

TABLE OF CONTENTS

Section	Page
1. Electrical Specifications	4
2. Typical Application Circuits	17
3. Functional Description	19
3.1. External Reference	20
3.2. Additional Documentation	20
3.3. Typical Phase Noise Performance	21
4. Register Map	24
5. Register Descriptions	26
5.1. ICAL	59
6. Pin Descriptions	60
7. Ordering Guide	64
8. Package Outline: 36-Pin QFN	67
9. PCB Land Pattern	68
10. Top Marking	70
10.1. Si5324 Top Marking (QFN)	70
10.2. Top Marking Explanation	70
Document Change List	71
Contact Information	72

1. Electrical Specifications

Table 1. Recommended Operating Conditions

Parameter	Symbol	Test Condition	Min	Typ	Max	Unit
Ambient Temperature	T_A		-40	25	85	°C
Supply Voltage during Normal Operation	V_{DD}	3.3 V Nominal	2.97	3.3	3.63	V
		2.5 V Nominal	2.25	2.5	2.75	V
		1.8 V Nominal	1.71	1.8	1.89	V

Note: All minimum and maximum specifications are guaranteed and apply across the recommended operating conditions. Typical values apply at nominal supply voltages and an operating temperature of 25 °C unless otherwise stated.

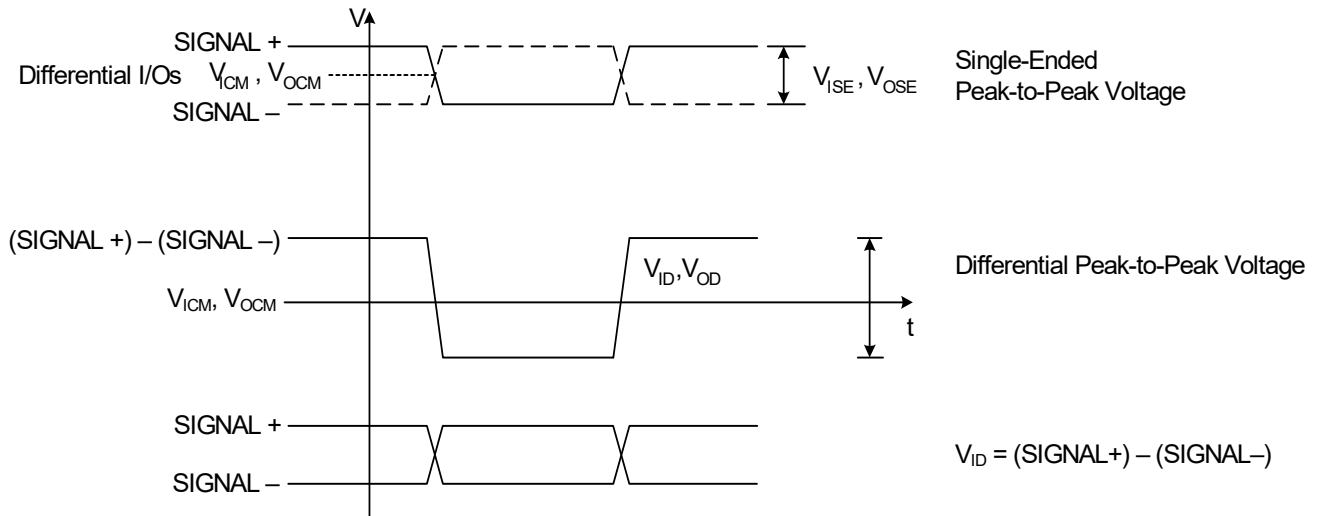

Figure 1. Differential Voltage Characteristics

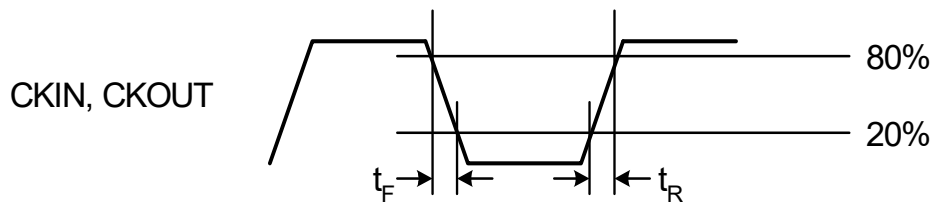

Figure 2. Rise/Fall Time Characteristics

Table 2. DC Characteristics $(V_{DD} = 1.8 \pm 5\%$, $2.5 \pm 10\%$, or $3.3 \text{ V} \pm 10\%$, $T_A = -40$ to $85 \text{ }^\circ\text{C}$)

Parameter	Symbol	Test Condition	Min	Typ	Max	Unit
Supply Current ¹	I_{DD}	LVPECL Format 622.08 MHz Out Both CKOUTs Enabled	—	251	279	mA
		LVPECL Format 622.08 MHz Out 1 CKOUT Enabled	—	217	243	mA
		CMOS Format 19.44 MHz Out Both CKOUTs Enabled	—	204	234	mA
		CMOS Format 19.44 MHz Out 1 CKOUT Enabled	—	194	220	mA
		Disable Mode	—	165	—	mA
CKINn Input Pins²						
Input Common Mode Voltage (Input Threshold Voltage)	V_{ICM}	$1.8 \text{ V} \pm 5\%$	0.9	—	1.4	V
		$2.5 \text{ V} \pm 10\%$	1	—	1.7	V
		$3.3 \text{ V} \pm 10\%$	1.1	—	1.95	V
Input Resistance	CKN_{RIN}	Single-ended	20	40	60	k Ω
Single-Ended Input Voltage Swing (See Absolute Specs)	V_{ISE}	$f_{CKIN} < 212.5 \text{ MHz}$ See Figure 1.	0.2	—	—	V_{PP}
		$f_{CKIN} > 212.5 \text{ MHz}$ See Figure 1.	0.25	—	—	V_{PP}
Differential Input Voltage Swing (See Absolute Specs)	V_{ID}	$f_{CKIN} < 212.5 \text{ MHz}$ See Figure 1.	0.2	—	—	V_{PP}
		$f_{CKIN} > 212.5 \text{ MHz}$ See Figure 1.	0.25	—	—	V_{PP}
Notes:						
1. Current draw is independent of supply voltage						
2. No under- or overshoot is allowed.						
3. LVPECL outputs require nominal $V_{DD} \geq 2.5 \text{ V}$.						
4. This is the amount of leakage that the 3-Level inputs can tolerate from an external driver. See Si53xx Family Reference Manual for more details.						
5. LVPECL, CML, LVDS and low-swing LVDS measured with $F_o = 622.08 \text{ MHz}$.						

Table 2. DC Characteristics (Continued)

($V_{DD} = 1.8 \pm 5\%$, $2.5 \pm 10\%$, or $3.3 \text{ V} \pm 10\%$, $T_A = -40$ to $85 \text{ }^\circ\text{C}$)

Parameter	Symbol	Test Condition	Min	Typ	Max	Unit
Output Clocks (CKOUTn)^{3,5}						
Common Mode	CKO_{VCM}	LVPECL 100 Ω load line-to-line	$V_{DD} - 1.42$	—	$V_{DD} - 1.25$	V
Differential Output Swing	CKO_{VD}	LVPECL 100 Ω load line-to-line	1.1	—	1.9	V_{PP}
Single Ended Output Swing	CKO_{VSE}	LVPECL 100 Ω load line-to-line	0.5	—	0.93	V_{PP}
Differential Output Voltage	CKO_{VD}	CML 100 Ω load line-to-line	350	425	500	mV_{PP}
Common Mode Output Voltage	CKO_{VCM}	CML 100 Ω load line-to-line	—	$V_{DD} - 0.36$	—	V
Differential Output Voltage	CKO_{VD}	LVDS 100 Ω load line-to-line	500	700	900	mV_{PP}
		Low Swing LVDS 100 Ω load line-to-line	350	425	500	mV_{PP}
Common Mode Output Voltage	CKO_{VCM}	LVDS 100 Ω load line-to-line	1.125	1.2	1.275	V
Differential Output Resistance	CKO_{RD}	CML, LVPECL, LVDS	—	200	—	Ω
Output Voltage Low	CKO_{VOLLH}	CMOS	—	—	0.4	V
Output Voltage High	CKO_{VOHLH}	$V_{DD} = 1.71 \text{ V}$ CMOS	$0.8 \times V_{DD}$	—	—	V
Notes:						
1. Current draw is independent of supply voltage						
2. No under- or overshoot is allowed.						
3. LVPECL outputs require nominal $V_{DD} \geq 2.5 \text{ V}$.						
4. This is the amount of leakage that the 3-Level inputs can tolerate from an external driver. See Si53xx Family Reference Manual for more details.						
5. LVPECL, CML, LVDS and low-swing LVDS measured with $F_o = 622.08 \text{ MHz}$.						

Table 2. DC Characteristics (Continued) $(V_{DD} = 1.8 \pm 5\%$, $2.5 \pm 10\%$, or $3.3 \text{ V} \pm 10\%$, $T_A = -40$ to $85 \text{ }^\circ\text{C}$)

Parameter	Symbol	Test Condition	Min	Typ	Max	Unit
Output Drive Current (CMOS driving into CKO_{VOL} for output low or CKO_{VOH} for output high. $CKOUT+$ and $CKOUT-$ shorted externally)	CKO_{IO}	$ICMOS[1:0] = 11$ $V_{DD} = 1.8 \text{ V}$	—	7.5	—	mA
		$ICMOS[1:0] = 10$ $V_{DD} = 1.8 \text{ V}$	—	5.5	—	mA
		$ICMOS[1:0] = 01$ $V_{DD} = 1.8 \text{ V}$	—	3.5	—	mA
		$ICMOS[1:0] = 00$ $V_{DD} = 1.8 \text{ V}$	—	1.75	—	mA
		$ICMOS[1:0] = 11$ $V_{DD} = 3.3 \text{ V}$	—	32	—	mA
		$ICMOS[1:0] = 10$ $V_{DD} = 3.3 \text{ V}$	—	24	—	mA
		$ICMOS[1:0] = 01$ $V_{DD} = 3.3 \text{ V}$	—	16	—	mA
		$ICMOS[1:0] = 00$ $V_{DD} = 3.3 \text{ V}$	—	8	—	mA
2-Level LVCMOS Input Pins						
Input Voltage Low	V_{IL}	$V_{DD} = 1.71 \text{ V}$	—	—	0.5	V
		$V_{DD} = 2.25 \text{ V}$	—	—	0.7	V
		$V_{DD} = 2.97 \text{ V}$	—	—	0.8	V
Input Voltage High	V_{IH}	$V_{DD} = 1.89 \text{ V}$	1.4	—	—	V
		$V_{DD} = 2.25 \text{ V}$	1.8	—	—	V
		$V_{DD} = 3.63 \text{ V}$	2.5	—	—	V
Notes:						
<ol style="list-style-type: none"> 1. Current draw is independent of supply voltage 2. No under- or overshoot is allowed. 3. LVPECL outputs require nominal $V_{DD} \geq 2.5 \text{ V}$. 4. This is the amount of leakage that the 3-Level inputs can tolerate from an external driver. See Si53xx Family Reference Manual for more details. 5. LVPECL, CML, LVDS and low-swing LVDS measured with $F_o = 622.08 \text{ MHz}$. 						

Si5324

Table 2. DC Characteristics (Continued)

($V_{DD} = 1.8 \pm 5\%$, $2.5 \pm 10\%$, or $3.3 \text{ V} \pm 10\%$, $T_A = -40$ to $85 \text{ }^\circ\text{C}$)

Parameter	Symbol	Test Condition	Min	Typ	Max	Unit
3-Level Input Pins⁴						
Input Voltage Low	V_{ILL}		—	—	$0.15 \times V_{DD}$	V
Input Voltage Mid	V_{IMM}		$0.45 \times V_{DD}$	—	$0.55 \times V_{DD}$	V
Input Voltage High	V_{IHH}		$0.85 \times V_{DD}$	—	—	V
Input Low Current	I_{ILL}	See Note 4	-20	—	—	μA
Input Mid Current	I_{IMM}	See Note 4	-2	—	+2	μA
Input High Current	I_{IHH}	See Note 4	—	—	20	μA
LVC MOS Output Pins						
Output Voltage Low	V_{OL}	$I_O = 2 \text{ mA}$ $V_{DD} = 1.71 \text{ V}$	—	—	0.4	V
Output Voltage Low		$I_O = 2 \text{ mA}$ $V_{DD} = 2.97 \text{ V}$	—	—	0.4	V
Output Voltage High	V_{OH}	$I_O = -2 \text{ mA}$ $V_{DD} = 1.71 \text{ V}$	$V_{DD} - 0.4$	—	—	V
Output Voltage High		$I_O = -2 \text{ mA}$ $V_{DD} = 2.97 \text{ V}$	$V_{DD} - 0.4$	—	—	V
Notes:						
<ol style="list-style-type: none"> 1. Current draw is independent of supply voltage 2. No under- or overshoot is allowed. 3. LVPECL outputs require nominal $V_{DD} \geq 2.5 \text{ V}$. 4. This is the amount of leakage that the 3-Level inputs can tolerate from an external driver. See Si53xx Family Reference Manual for more details. 5. LVPECL, CML, LVDS and low-swing LVDS measured with $F_o = 622.08 \text{ MHz}$. 						

Table 3. AC Characteristics $(V_{DD} = 1.8 \pm 5\%, 2.5 \pm 10\%, \text{ or } 3.3 \text{ V} \pm 10\%, T_A = -40 \text{ to } 85 \text{ }^\circ\text{C})$

Parameter	Symbol	Test Condition	Min	Typ	Max	Unit
Single-Ended Reference Clock Input Pin XA (XB with cap to GND)						
Input Resistance	XA_{RIN}	RATE[1:0] = LM, ML, MH, or HM, ac coupled	—	12	—	k Ω
Input Voltage Swing	XA_{VPP}	RATE[1:0] = LM, ML, MH, or HM, ac coupled	0.5	—	1.2	V_{PP}
Differential Reference Clock Input Pins (XA/XB)						
Input Voltage Swing	XA/XB_{VPP}	RATE[1:0] = LM, ML, MH, or HM	0.5	—	2.4	V_{PP}
CKINn Input Pins						
Input Frequency	CKN_F		0.002	—	710	MHz
Input Duty Cycle (Minimum Pulse Width)	CKN_{DC}	Whichever is smaller (i.e., the 40% / 60% limitation applies only to high-frequency clocks)	40	—	60	%
			2	—	—	ns
Input Capacitance	CKN_{CIN}		—	—	3	pF
Input Rise/Fall Time	CKN_{TRF}	20–80% See Figure 2	—	—	11	ns
CKOUTn Output Pins						
(See ordering section for speed grade vs frequency limits)						
Output Frequency (Output not configured for CMOS or Disabled)	CKO_F	$N1 \geq 6$	0.002	—	945	MHz
		$N1 = 5$	970	—	1134	MHz
		$N1 = 4$	1.213	—	1.4	GHz
Maximum Output Frequency in CMOS Format	CKO_F		—	—	212.5	MHz
Notes:						
1. Input to output phase skew after an ICAL is not controlled and can assume any value.						
2. Lock and settle time performance is dependent on the frequency plan, the XAXB reference frequency, and LOCKT setting (see application note, "AN803: Lock and Settling Time Considerations for Si5324/27/69/74 Any-Frequency Jitter Attenuating Clock ICs". Visit the Skyworks Solutions Technical Support web page at: https://www.skyworksinc.com/en/Support to submit a technical support request regarding the lock time of your frequency plan.						
3. LOCKT = 3.3 ms						

Table 3. AC Characteristics (Continued)(V_{DD} = 1.8 ± 5%, 2.5 ± 10%, or 3.3 V ± 10%, T_A = -40 to 85 °C)

Parameter	Symbol	Test Condition	Min	Typ	Max	Unit
Output Rise/Fall (20–80 %) @ 622.08 MHz output	CKO _{TRF}	Output not configured for CMOS or Disabled See Figure 2	—	230	350	ps
Output Rise/Fall (20–80%) @ 212.5 MHz output	CKO _{TRF}	CMOS Output V _{DD} = 1.71 C _{LOAD} = 5 pF	—	—	8	ns
Output Rise/Fall (20–80%) @ 212.5 MHz output	CKO _{TRF}	CMOS Output V _{DD} = 2.97 C _{LOAD} = 5 pF	—	—	2	ns
Output Duty Cycle Uncertainty @ 622.08 MHz	CKO _{DC}	100 Ω Load Line-to-Line Measured at 50% Point (Not for CMOS)	—	—	+/-40	ps
LVC MOS Input Pins						
Minimum Reset Pulse Width	t _{RSTMN}		1			μs
Reset to Microprocessor Access Ready	t _{READY}				10	ms
LVC MOS Output Pins						
Rise/Fall Times	t _{RF}	C _{LOAD} = 20pf See Figure 2	—	25	—	ns
LOS _n Trigger Window	LOS _{TRIG}	From last CKIN _n ↑ to ↓ Internal detection of LOS _n N3 ≠ 1	—	—	4.5 x N3	T _{CKIN}
Time to Clear LOL after LOS Cleared	t _{CLRLOL}	↓LOS to ↓LOL Fold = F _{new} Stable Xa/XB reference	—	10	—	ms
Notes:						
<ol style="list-style-type: none"> 1. Input to output phase skew after an ICAL is not controlled and can assume any value. 2. Lock and settle time performance is dependent on the frequency plan, the XAXB reference frequency, and LOCKT setting (see application note, "AN803: Lock and Settling Time Considerations for Si5324/27/69/74 Any-Frequency Jitter Attenuating Clock ICs". Visit the Skyworks Solutions Technical Support web page at: https://www.skyworksinc.com/en/Support to submit a technical support request regarding the lock time of your frequency plan. 3. LOCKT = 3.3 ms 						

Table 3. AC Characteristics (Continued)(V_{DD} = 1.8 ± 5%, 2.5 ± 10%, or 3.3 V ± 10%, T_A = -40 to 85 °C)

Parameter	Symbol	Test Condition	Min	Typ	Max	Unit
Device Skew						
Output Clock Skew	t _{SKEW}	↑ of CKOUT _n to ↑ of CKOUT _m , CKOUT _n and CKOUT _m at same frequency and signal format PHASEOFFSET = 0 CKOUT_ALWAYS_ON = 1 SQ_ICAL = 1	—	—	100	ps
Phase Change due to Temperature Variation ¹	t _{TEMP}	Max phase changes from -40 to +85 °C	—	300	500	ps
PLL Performance (fin = fout = 622.08 MHz; BW = 7 Hz; LVPECL, XAXB = 114.285 MHz)						
Lock Time ² Si5324E-C-GM ³	t _{LOCKMP}	Start of ICAL to ↓ of LOL	—	1	1.5	s
Si5324A/B/C/D-C-GM			—	0.8	1.0	
Settle Time ² Si5324E-C-GM	t _{SETTLE}	Start of ICAL to Fout within 5 ppm of final value	—	1.2	1.5	s
Si5324A/B/C/D-C-GM			—	4.2	5.0	
Output Clock Phase Change	t _{P_STEP}	After clock switch f3 ≥ 128 kHz	—	200	—	ps
Closed Loop Jitter Peaking	J _{PK}		—	0.05	0.1	dB
Jitter Tolerance	J _{TOL}	Jitter Frequency ≥ Loop Bandwidth	5000/BW	—	—	ns pk-pk
Notes:						
1. Input to output phase skew after an ICAL is not controlled and can assume any value.						
2. Lock and settle time performance is dependent on the frequency plan, the XAXB reference frequency, and LOCKT setting (see application note, "AN803: Lock and Settling Time Considerations for Si5324/27/69/74 Any-Frequency Jitter Attenuating Clock ICs". Visit the Skyworks Solutions Technical Support web page at: https://www.skyworksinc.com/en/Support to submit a technical support request regarding the lock time of your frequency plan.						
3. LOCKT = 3.3 ms						

Table 3. AC Characteristics (Continued)

($V_{DD} = 1.8 \pm 5\%$, $2.5 \pm 10\%$, or $3.3 V \pm 10\%$, $T_A = -40$ to $85\text{ }^\circ\text{C}$)

Parameter	Symbol	Test Condition	Min	Typ	Max	Unit
Phase Noise $f_{out} = 622.08\text{ MHz}$	CKO _{PN}	100 Hz Offset	—	-90	—	dBc/Hz
		1 kHz Offset	—	-106	—	dBc/Hz
		10 kHz Offset	—	-121	—	dBc/Hz
		100 kHz Offset	—	-132	—	dBc/Hz
		1 MHz Offset	—	-132	—	dBc/Hz
Subharmonic Noise	SP _{SUBH}	Phase Noise @ 100 kHz Offset	—	-88	-76	dBc
Spurious Noise	SP _{SPUR}	Max spur @ $n \times F3$ ($n \geq 1$, $n \times F3 < 100\text{ MHz}$)	—	-93	-70	dBc

Notes:

1. Input to output phase skew after an ICAL is not controlled and can assume any value.
2. Lock and settle time performance is dependent on the frequency plan, the XAXB reference frequency, and LOCKT setting (see application note, "AN803: Lock and Settling Time Considerations for Si5324/27/69/74 Any-Frequency Jitter Attenuating Clock ICs". Visit the Skyworks Solutions Technical Support web page at: <https://www.skyworksinc.com/en/Support> to submit a technical support request regarding the lock time of your frequency plan.
3. LOCKT = 3.3 ms

Table 4. Microprocessor Control $(V_{DD} = 1.8 \pm 5\%, 2.5 \pm 10\%, \text{ or } 3.3 \text{ V} \pm 10\%, T_A = -40 \text{ to } 85 \text{ }^\circ\text{C})$

Parameter	Symbol	Test Condition	Min	Typ	Max	Unit
I²C Bus Lines (SDA, SCL)						
Input Voltage Low	$V_{IL_{I2C}}$		—	—	$0.25 \times V_{DD}$	V
Input Voltage High	$V_{IH_{I2C}}$		$0.7 \times V_{DD}$	—	V_{DD}	V
Hysteresis of Schmitt trigger inputs	$V_{HYS_{I2C}}$	$V_{DD} = 1.8\text{V}$	$0.1 \times V_{DD}$	—	—	V
		$V_{DD} = 2.5 \text{ or } 3.3 \text{ V}$	$0.05 \times V_{DD}$	—	—	V
Output Voltage Low	$V_{OL_{I2C}}$	$V_{DD} = 1.8 \text{ V}$ $I_O = 3 \text{ mA}$	—	—	$0.2 \times V_{DD}$	V
		$V_{DD} = 2.5 \text{ or } 3.3 \text{ V}$ $I_O = 3 \text{ mA}$	—	—	0.4	V

Table 4. Microprocessor Control (Continued)

($V_{DD} = 1.8 \pm 5\%$, $2.5 \pm 10\%$, or $3.3 V \pm 10\%$, $T_A = -40$ to $85\text{ }^\circ\text{C}$)

Parameter	Symbol	Test Condition	Min	Typ	Max	Unit
SPI Specifications						
Duty Cycle, SCLK	t_{DC}	SCLK = 10 MHz	40	—	60	%
Cycle Time, SCLK	t_c		100	—	—	ns
Rise Time, SCLK	t_r	20–80%	—	—	25	ns
Fall Time, SCLK	t_f	20–80%	—	—	25	ns
Low Time, SCLK	t_{lsc}	20–20%	30	—	—	ns
High Time, SCLK	t_{hsc}	80–80%	30	—	—	ns
Delay Time, SCLK Fall to SDO Active	t_{d1}		—	—	25	ns
Delay Time, SCLK Fall to SDO Transition	t_{d2}		—	—	25	ns
Delay Time, SS Rise to SDO Tri-state	t_{d3}		—	—	25	ns
Setup Time, SS to SCLK Fall	t_{su1}		25	—	—	ns
Hold Time, SS to SCLK Rise	t_{h1}		20	—	—	ns
Setup Time, SDI to SCLK Rise	t_{su2}		25	—	—	ns
Hold Time, SDI to SCLK Rise	t_{h2}		20	—	—	ns
Delay Time between Slave Selects	t_{cs}		25	—	—	ns

Table 5. Jitter Generation

Parameter	Symbol	Test Condition*		Min	Typ	Max	GR-253-Specification	Unit
		Measurement Filter	DSPLL BW ²					
Jitter Gen OC-192	JGEN	0.02–80 MHz	120 Hz	—	4.2	6.2	30	ps _{pp}
				—	.27	.42	N/A	ps _{rms}
		4–80 MHz	120 Hz	—	3.7	6.4	10	ps _{pp}
				—	.14	0.31	N/A	ps _{rms}
		0.05–80 MHz	120 Hz	—	4.4	6.9	10	ps _{pp}
				—	.26	0.41	1.0	ps _{rms}
Jitter Gen OC-48	JGEN	0.12–20 MHz	120 Hz	—	3.5	5.4	40.2	ps _{pp}
				—	.27	0.41	4.02	ps _{rms}

***Note:** Test conditions:
 1. $f_{IN} = f_{OUT} = 622.08$ MHz
 2. Clock input: LVPECL
 3. Clock output: LVPECL
 4. PLL bandwidth: 120 Hz
 5. 114.285 MHz 3rd OT crystal used as XA/XB input
 6. $V_{DD} = 2.5$ V
 7. $T_A = 85$ °C

Table 6. Thermal Characteristics

($V_{DD} = 1.8 \pm 5\%$, $2.5 \pm 10\%$, or 3.3 V $\pm 10\%$, $T_A = -40$ to 85 °C)

Parameter	Symbol	Test Condition	Value	Unit
Thermal Resistance Junction to Ambient	θ_{JA}	Still Air	32	°C/W
Thermal Resistance Junction to Case	θ_{JC}	Still Air	14	°C/W

Si5324

Table 7. Absolute Maximum Ratings*

Parameter	Symbol	Test Condition	Min	Typ	Max	Unit
DC Supply Voltage	V_{DD}		-0.5	—	3.8	V
LVC MOS Input Voltage	V_{DIG}		-0.3		$V_{DD}+0.3$	V
CKINn Voltage Level Limits	CKN_{VIN}		0	—	V_{DD}	V
XA/XB Voltage Level Limits	XA_{VIN}		0	—	1.2	V
Operating Junction Temperature	T_{JCT}		-55	—	150	°C
Storage Temperature Range	T_{STG}		-55	—	150	°C
ESD HBM Tolerance (100 pF, 1.5 kΩ); All pins except CKIN+/CKIN-			2	—	—	kV
ESD MM Tolerance; All pins except CKIN+/CKIN-			150	—	—	V
ESD HBM Tolerance (100 pF, 1.5 kΩ); CKIN+/CKIN-			750	—	—	V
ESD MM Tolerance; CKIN+/CKIN-			100	—	—	V
Latch-up Tolerance			JESD78 Compliant			
<p>*Note: Permanent device damage may occur if the absolute maximum ratings are exceeded. Functional operation should be restricted to the conditions specified in the operation sections of this data sheet. Exposure to absolute maximum rating conditions for extended periods of time may affect device reliability.</p>						

2. Typical Application Circuits

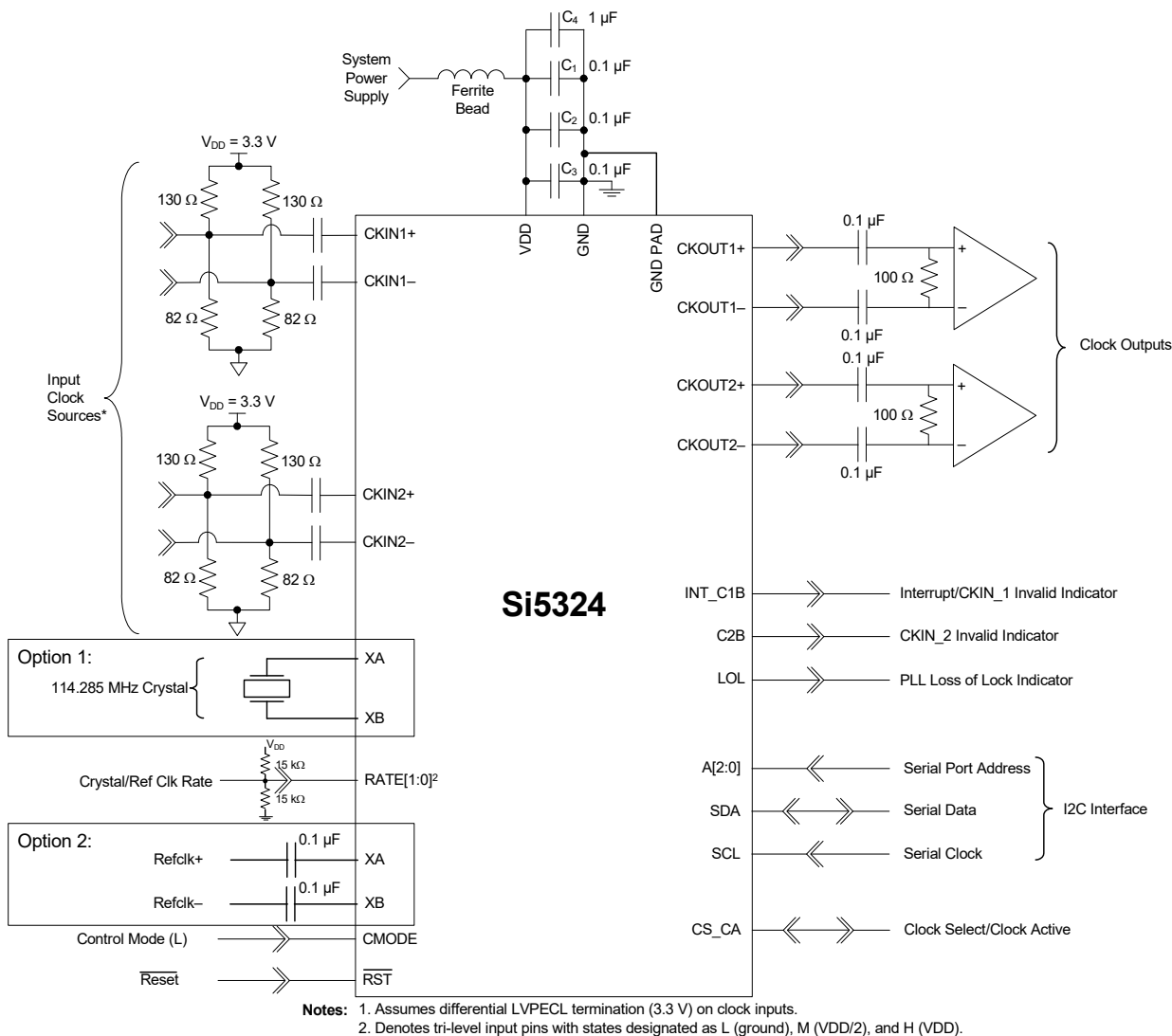

Figure 3. Si5324 Typical Application Circuit (I²C Control Mode)

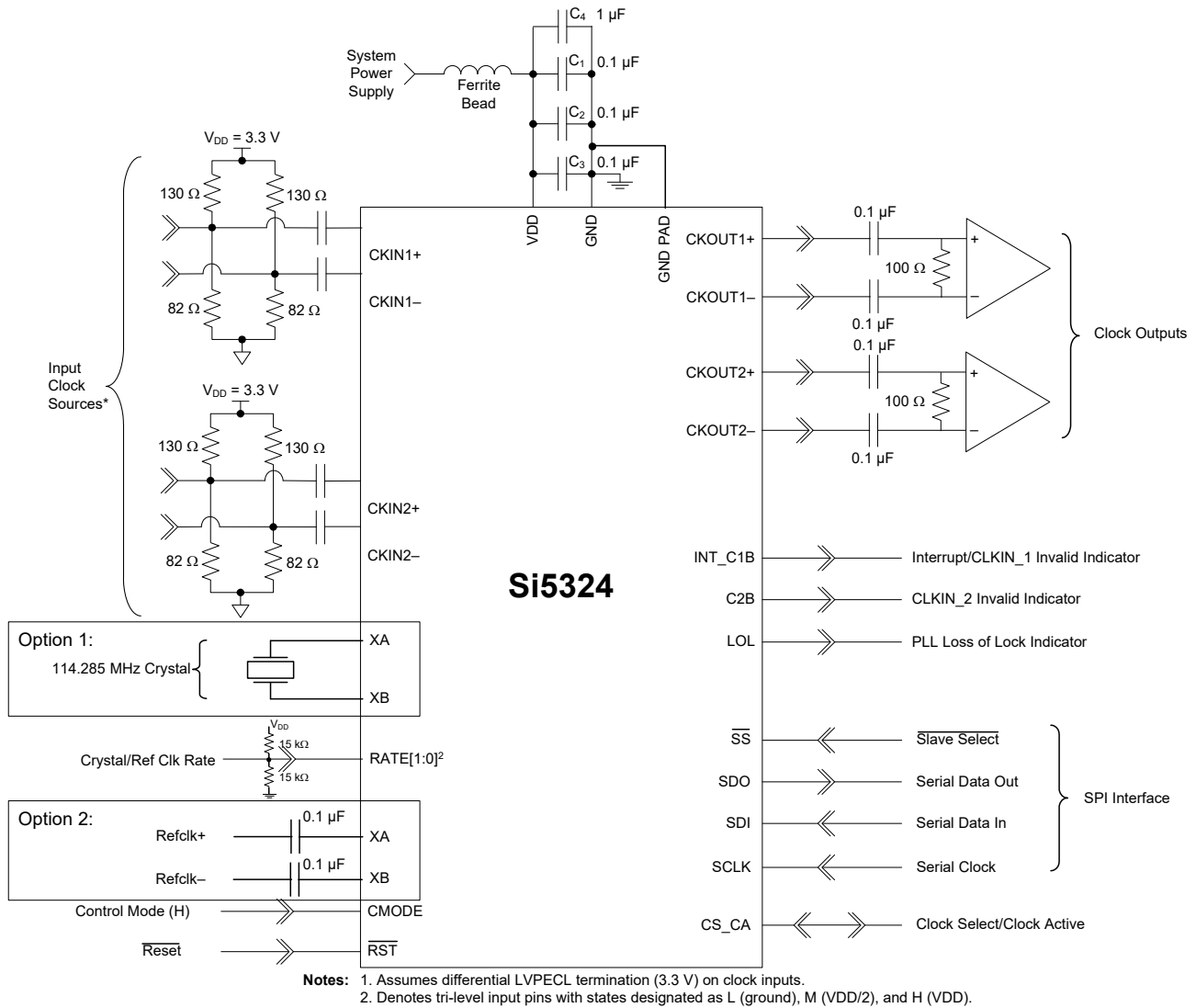

Figure 4. Si5324 Typical Application Circuit (SPI Control Mode)

3. Functional Description

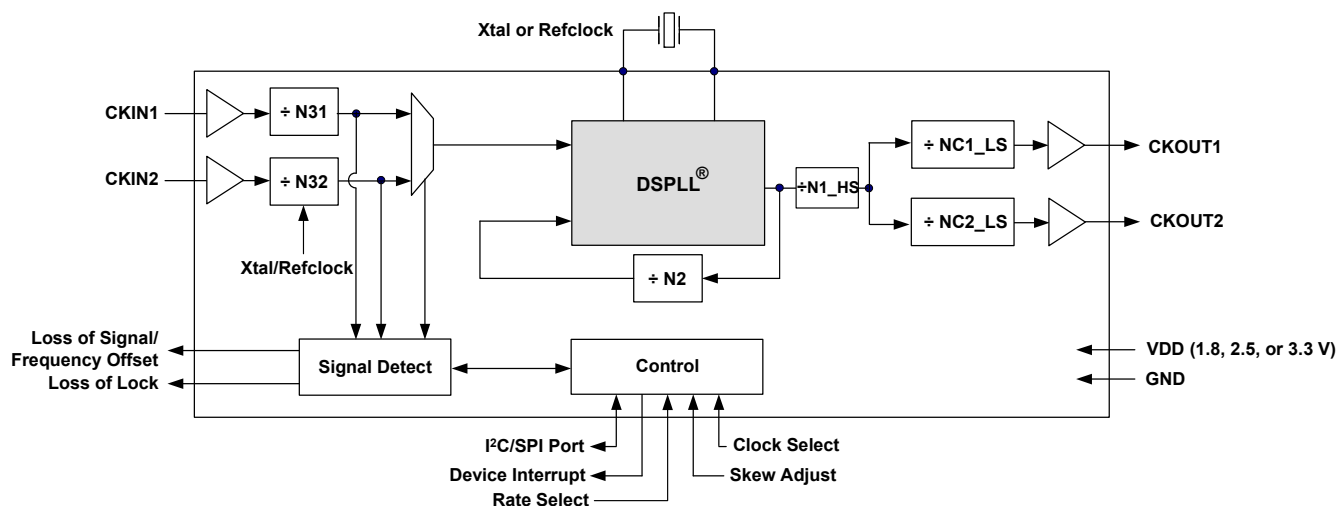

Figure 5. Si5324 Functional Block Diagram

The Si5324 is a low loop bandwidth, jitter-attenuating clock multiplier for high performance applications. The Si5324 accepts two input clocks ranging from 2 kHz to 710 MHz and generates two output clocks ranging from 2 kHz to 945 MHz and select frequencies to 1.4 GHz. The Si5324 can also use its external reference as a clock source for frequency synthesis. The device provides virtually any frequency translation combination across this operating range. Independent dividers are available for each input clock and output clock, so the Si5324 can accept input clocks at different frequencies and it can generate output clocks at different frequencies. The Si5324 input clock frequency and clock multiplication ratio are programmable through an I²C or SPI interface. Skyworks Solutions offers a PC-based software utility, *DSPLLsim*, that can be used to determine the optimum PLL divider settings for a given input frequency/clock multiplication ratio combination that minimizes phase noise and power consumption. This utility can be downloaded from <https://www.skyworksinc.com/en/Products/Timing>.

The Si5324 is based on Skyworks Solutions' 3rd-generation DSPLL[®] technology, which provides any-frequency synthesis and jitter attenuation in a highly integrated PLL solution that eliminates the need for external VCXO and loop filter components. The Si5324 PLL loop bandwidth is digitally programmable and supports a range from 4 Hz to 525 Hz. A fast lock feature is available to reduce lock times inherent with low loop bandwidth PLLs. The *DSPLLsim* software utility can be used to calculate valid loop bandwidth settings for a given input clock frequency/clock multiplication ratio.

The Si5324 supports hitless switching between the two synchronous input clocks in compliance with Telcordia GR-253-CORE that greatly minimizes the propagation of phase transients to the clock outputs during an input clock transition (maximum 200 ps phase change). Manual and automatic revertive and non-revertive input clock switching options are available. The Si5324 monitors both input clocks for loss-of-signal (LOS) and provides a LOS alarm when it detects missing pulses on either input clock. The device monitors the lock status of the PLL. The lock detect algorithm works by continuously monitoring the phase of the input clock in relation to the phase of the feedback clock. Due to the low loop bandwidth of the part, the LOL indicator clears before the loop fully settles (see "AN803: Lock and Settling Time Considerations for Si5324/27/69/74 Any-Frequency Jitter Attenuating Clock ICs" for additional details).

The Si5324 also monitors frequency offset alarms (FOS), which indicate if an input clock is within a specified frequency ppm accuracy relative to the frequency of an XA/XB reference clock. Both Stratum 3/3E and SONET Minimum Clock (SMC) FOS thresholds are supported.

The Si5324 provides a digital hold capability that allows the device to continue generation of a stable output clock when the selected input reference is lost. During digital hold, the DSPLL generates an output frequency based on a historical average frequency that existed a fixed amount of time before the error event occurred, eliminating the effects of phase and frequency transients that may occur immediately preceding digital hold.

The Si5324 has two differential clock outputs. The signal format of each clock output is independently programmable to support LVPECL, LVDS, CML, or CMOS loads. When configured for CMOS, four clock outputs are available. If not required, the second clock output can be powered-down to minimize power consumption. In addition, the phase of one output clock may be adjusted in relation to the phase of the other output clock. The resolution varies from 800 ps to 2.2 ns depending on the PLL divider settings. The *DSPLLsim* software utility determines the phase offset resolution for a given combination of input clock and multiplication ratio.

For system-level debugging, a bypass mode is available which drives the output clock directly from the input clock, bypassing the internal DSPLL. The device is powered by a single 1.8, 2.5, or 3.3 V supply with best-in-class PSNR.

3.1. External Reference

An external, high quality 38.88 MHz clock or a low-cost 114.285 MHz 3rd overtone crystal or external reference is used as part of a fixed-frequency oscillator within the DSPLL. This external reference is required for the device to perform jitter attenuation. Specific recommendations can be found in the Family Reference Manual.

In digital hold, the DSPLL remains locked and tracks the external reference. Note that crystals can have temperature sensitivities.

Due to the low bandwidth capabilities of this part, any low-frequency wander or instability on the external reference will transfer to the output clocks. To address this issue, a stable external reference, TXCO, OCXO, or thermally-isolated crystal is recommended.

For example, with a 20 ppm oscillator as the reference on the XA/XB pins, temperature changes cause the oscillator to change frequency slightly. Although the Si5324 is locked to its input on CLKIN, it also uses the XA/XB as a reference.

If there is a need to use a reference oscillator instead of a crystal, Skyworks Solutions does not recommend using MEMS based oscillators. Instead, Skyworks Solutions recommends the Si530EB121M109DG, which is a very low-jitter/wander, LVPECL, 2.5 V crystal oscillator. The very low loop BW of the Si5324 means that it can be susceptible to XAXB reference sources that have high wander. Experience has shown that in spite of having low jitter, some MEMs oscillators have high wander, and these devices should be avoided. Contact Skyworks Solutions for details.

3.2. Additional Documentation

Consult the Skyworks Solutions Any-Frequency Precision Clock Family Reference Manual (FRM) for detailed information about the Si5324. Additional design support is available from Skyworks Solutions through your distributor.

Skyworks Solutions offers a PC-based software utility called *DSPLLsim* to simplify device configuration, including frequency planning and loop bandwidth selection. The FRM and this utility can be downloaded from <https://www.skyworksinc.com/en/Products/Timing> (see “AN803: Lock and Settling Time Considerations for Si5324/27/69/74 Any-Frequency Jitter Attenuating Clock ICs” for additional details).

3.3. Typical Phase Noise Performance

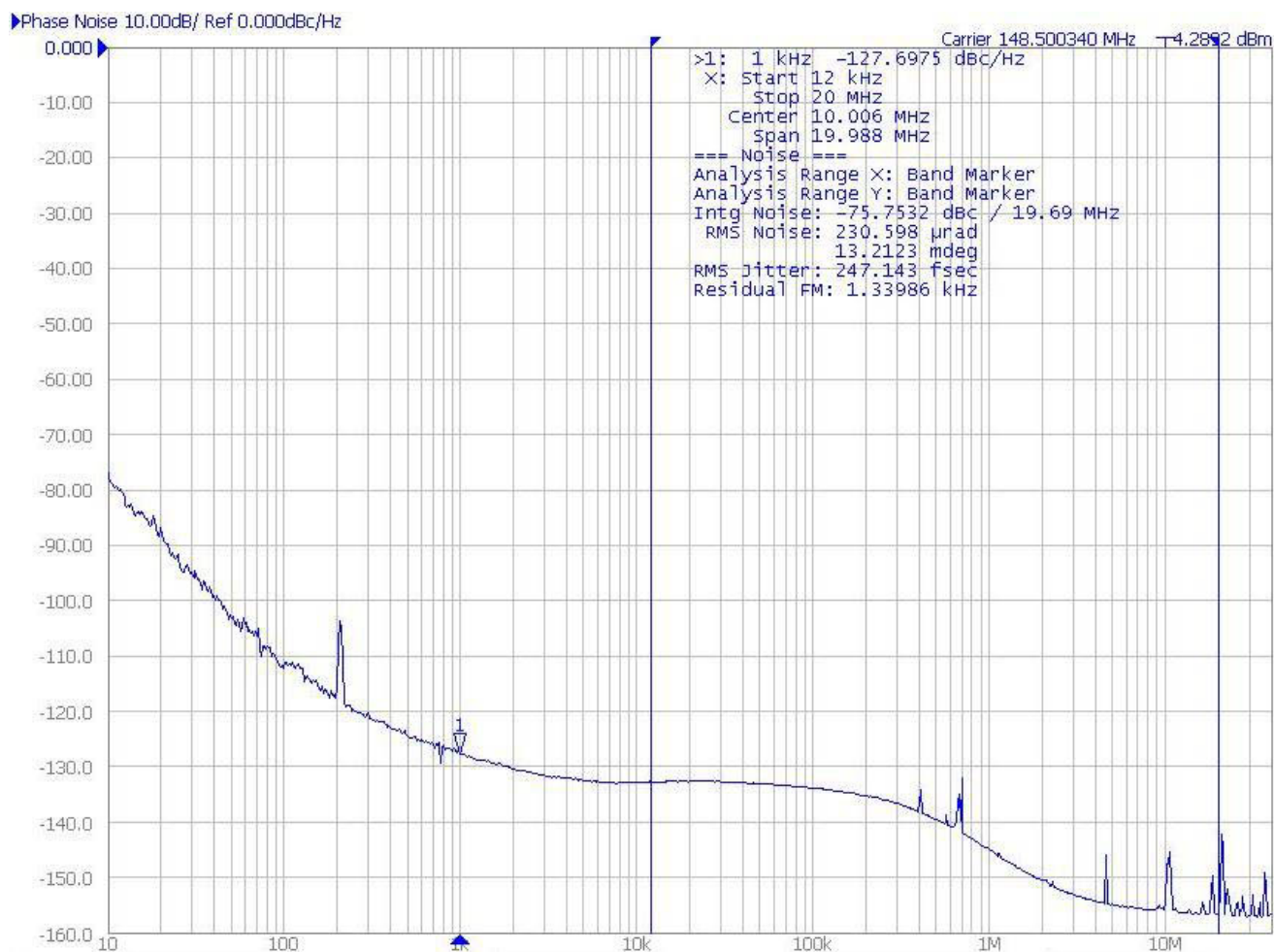

Figure 6. Broadcast Video

Table 8. Broadcast Video Jitter¹

Jitter Bandwidth ²	Jitter (Peak-Peak)	Jitter (RMS)
10 Hz to 20 MHz	5.24 ps	484 fs

Notes:

1. Number of samples: 8.91E9.
2. Jitter integration bands include low-pass (-20 dB/Dec) and hi-pass (-60 dB/Dec) roll-offs per Telecordia GR-253-CORE.

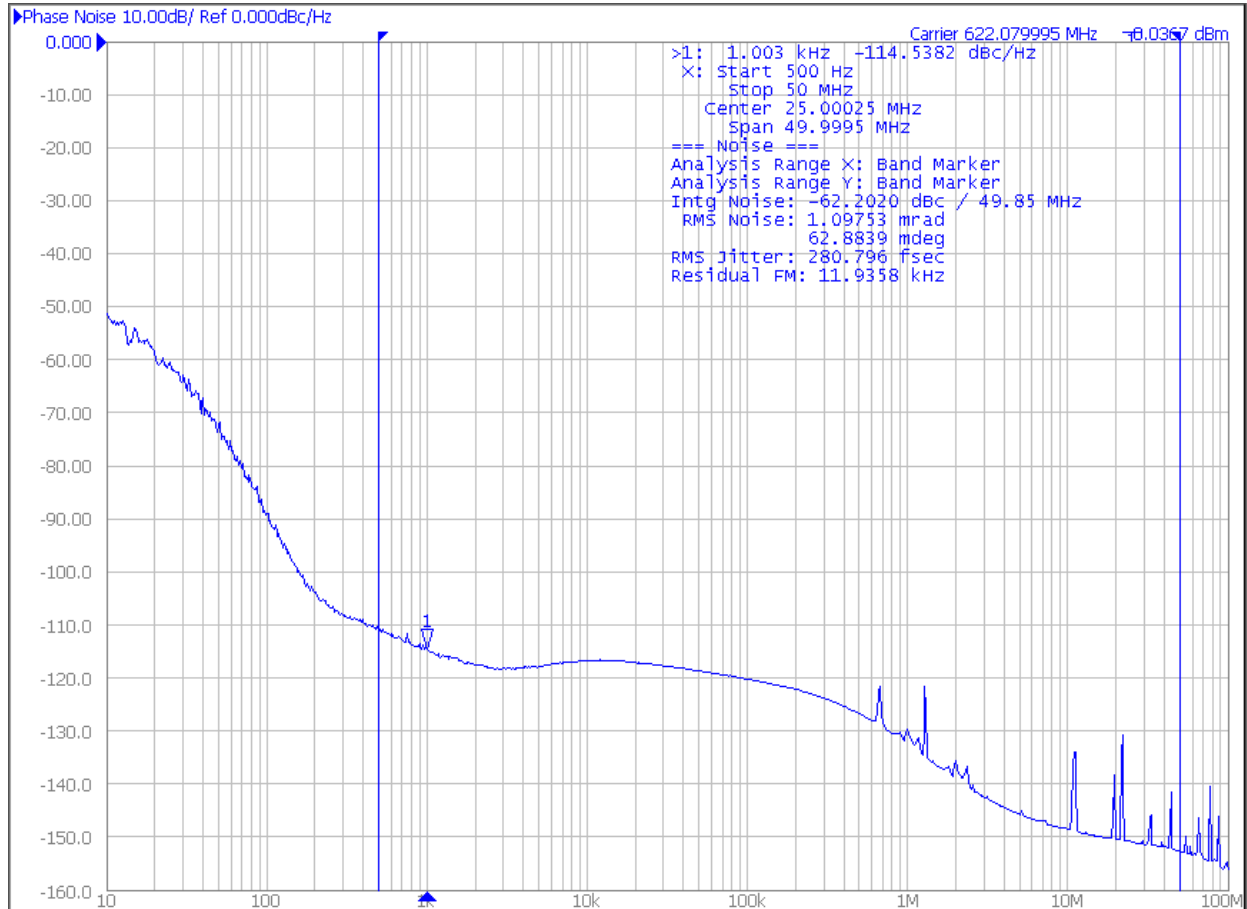

Figure 7. OTN/SONET/SDH Phase Noise

Note: Phase noise plot uses brick wall integration.

Table 9. SONET Jitter

Jitter Bandwidth*	Jitter, RMS
SONET_OC48, 12 kHz to 20 MHz	266 fs
SONET_OC192_A, 20 kHz to 80 MHz	283 fs
SONET_OC192_B, 4 MHz to 80 MHz	155 fs
SONET_OC192_C, 50 kHz to 80 MHz	275 fs
Brick Wall_800 Hz to 80 MHz	287 fs

***Note:** Jitter integration bands include low-pass (-20 dB/Dec) and hi-pass (-60 dB/Dec) roll-offs per Telecordia GR-253-CORE.

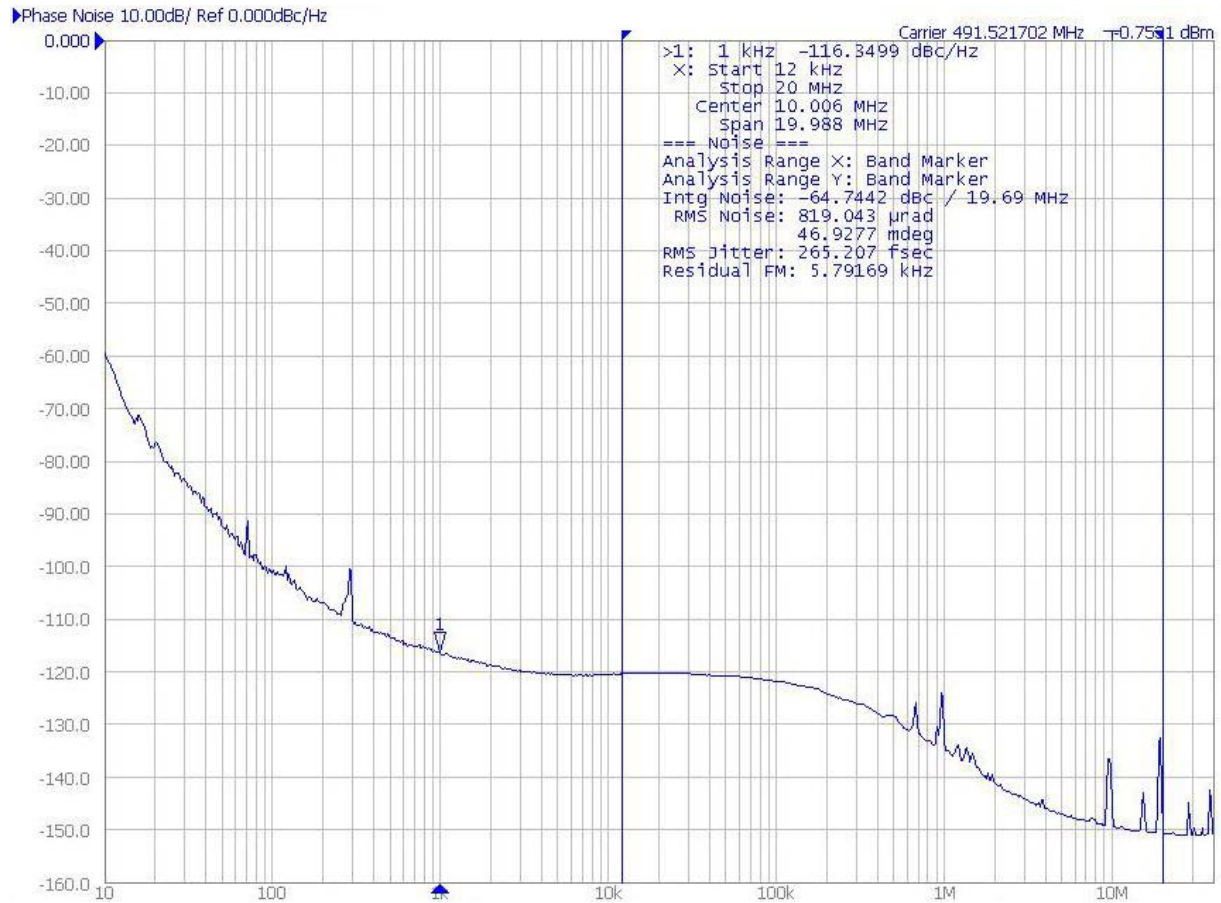

Figure 8. Wireless Base Station Phase Noise

Table 10. Wireless Base Station Jitter*

Jitter Bandwidth	Jitter (peak-peak)	Jitter (RMS)
10 Hz to 20 MHz	7.28 ps	581 fs
Note: Number of samples: 8.91E9		

Si5324

4. Register Map

All register bits that are not defined in this map should always be written with the specified Reset Values. The writing to these bits of values other than the specified Reset Values may result in undefined device behavior. Registers not listed, e.g. Register 64, should never be written to.

Register	D7	D6	D5	D4	D3	D2	D1	D0
0		FREE_RUN	CKOUT_ALWAYS_ON				BYPASS_REG	
1					CK_PRIOR2[1:0]		CK_PRIOR1[1:0]	
2	BWSEL_REG[3:0]							
3	CKSEL_REG[1:0]		DHOLD	SQ_ICAL				
4	AUTOSEL_REG[1:0]			HST_DEL[4:0]				
5	ICMOS[1:0]							
6			SFOUT2_REG[2:0]			SFOUT1_REG[2:0]		
7						FOSREFSEL[2:0]		
8	HLOG_2[1:0]		HLOG_1[1:0]					
9	HIST_AVG[4:0]							
10					DSBL2_REG	DSBL1_REG		
11							PD_CK2	PD_CK1
19	FOS_EN	FOS_THR[1:0]		VALTIME[1:0]		LOCK[T2:0]		
20					CK2_BAD_PIN	CK1_BAD_PIN	LOL_PIN	INT_PIN
21							CK1_ACTV_PIN	CKSEL_PIN
22					CK_ACTV_POL	CK_BAD_POL	LOL_POL	INT_POL
23						LOS2_MSK	LOS1_MSK	LOSX_MSK
24						FOS2_MSK	FOS1_MSK	LOL_MSK
25	N1_HS[2:0]							
31					NC1_LS[19:16]			
32					NC1_LS[15:8]			
33					NC1_LS[7:0]			
34					NC2_LS[19:16]			
35					NC2_LS[15:8]			
36					NC2_LS[7:0]			
40	N2_HS[2:0]				N2_LS[19:16]			
41					N2_LS[15:8]			
42					N2_LS[7:0]			
43						N31[18:16]		
44					N31[15:8]			
45					N31[7:0]			
46						N32[18:16]		

Register	D7	D6	D5	D4	D3	D2	D1	D0
47	N32[15:8]							
48	N32[7:0]							
55			CLKIN2RATE[2:0]			CLKIN1RATE[2:0]		
128							CK2_ACTV_REG	CK1_ACTV_REG
129						LOS2_INT	LOS1_INT	LOSX_INT
130		DIGHOLD- VALID				FOS2_INT	FOS1_INT	LOL_INT
131						LOS2_FLG	LOS1_FLG	LOSX_FLG
132					FOS2_FLG	FOS1_FLG	LOL_FLG	
134	PARTNUM_RO[11:4]							
135	PARTNUM_RO[3:0]				REVID_RO[3:0]			
136	RST_REG	ICAL						
137								FASTLOCK
138							LOS2_EN [1:1]	LOS1_EN [1:1]
139			LOS2_EN[0:0]	LOS1_EN[0:0]			FOS2_EN	FOS1_EN
142	INDEPENDENTSKEW1[7:0]							
143	INDEPENDENTSKEW2[7:0]							

Table 11. CKOUT_ALWAYS_ON and SQ_ICAL Truth Table

CKOUT_ALWAYS_ON	SQ_ICAL	Results
0	0	CKOUT OFF until after the first ICAL
0	1	CKOUT OFF until after the first successful ICAL (i.e., when LOL is low)
1	0	CKOUT always ON, including during an ICAL
1	1	CKOUT always ON, including during an ICAL. Use these settings to preserve output-to-output skew

5. Register Descriptions

Register 0.

Bit	D7	D6	D5	D4	D3	D2	D1	D0
Name		FREE_RUN	CKOUT_ALWAYS_ON				BYPASS_REG	
Type	R	R/W	R/W	R	R	R	R/W	R

Reset value = 0001 0100

Bit	Name	Function
7	Reserved	Reserved.
6	FREE_RUN	Free Run. Internal to the device, route XA/XB to CKIN2. This allows the device to lock to its XA-XB reference. 0: Disable 1: Enable
5	CKOUT_ALWAYS_ON	CKOUT Always On. This will bypass the SQ_ICAL function. Output will be available even if SQ_ICAL is on and ICAL is not complete or successful. See Table 11 on page 25. 0: Squelch output until part is calibrated (ICAL). 1: Provide an output. Notes: 1. The frequency may be significantly off until the part is calibrated. 2. Must be 1 to control output to output skew.
4:2	Reserved	Reserved.
1	BYPASS_REG	Bypass Register. This bit enables or disables the PLL bypass mode. Use only when the device is in digital hold or before the first ICAL. Bypass mode is not supported for CMOS output clocks. 0: Normal operation 1: Bypass mode. Selected input clock is connected to CKOUT buffers, bypassing PLL.
0	Reserved	Reserved.

Register 1.

Bit	D7	D6	D5	D4	D3	D2	D1	D0
Name					CK_PRIOR2 [1:0]		CK_PRIOR1 [1:0]	
Type	R	R	R	R	R/W		R/W	

Reset value = 1110 0100

Bit	Name	Function
7:4	Reserved	Reserved.
3:2	CK_PRIOR2 [1:0]	CK_PRIOR 2. Selects which of the input clocks will be 2nd priority in the autoselection state machine. 00: CKIN1 is 2nd priority. 01: CKIN2 is 2nd priority. 10: Reserved 11: Reserved
1:0	CK_PRIOR1 [1:0]	CK_PRIOR 1. Selects which of the input clocks will be 1st priority in the autoselection state machine. 00: CKIN1 is 1st priority. 01: CKIN2 is 1st priority. 10: Reserved 11: Reserved

Register 2.

Bit	D7	D6	D5	D4	D3	D2	D1	D0
Name	BWSEL_REG [3:0]							
Type	R/W				R	R	R	R

Reset value = 0100 0010

Bit	Name	Function
7:4	BWSEL_REG [3:0]	BWSEL_REG. Selects nominal f3dB bandwidth for PLL. See the DSPLLsim for settings. After BWSEL_REG is written with a new value, an ICAL is required for the change to take effect.
3:0	Reserved	Reserved.

Register 3.

Bit	D7	D6	D5	D4	D3	D2	D1	D0
Name	CKSEL_REG [1:0]		DHOLD	SQ_ICAL				
Type	R/W		R/W	R/W	R	R	R	R

Reset value = 0000 0101

Bit	Name	Function
7:6	CKSEL_REG [1:0]	<p>CKSEL_REG.</p> <p>If the device is operating in register-based manual clock selection mode (AUTOSEL_REG = 00), and CKSEL_PIN = 0, then these bits select which input clock will be the active input clock. If CKSEL_PIN = 1 and AUTOSEL_REG = 00, the CS_CA input pin continues to control clock selection and CKSEL_REG is of no consequence.</p> <p>00: CKIN_1 selected. 01: CKIN_2 selected. 10: Reserved 11: Reserved</p>
5	DHOLD	<p>DHOLD.</p> <p>Forces the part into digital hold. This bit overrides all other manual and automatic clock selection controls.</p> <p>0: Normal operation. 1: Force digital hold mode. Overrides all other settings and ignores the quality of all of the input clocks.</p>
4	SQ_ICAL	<p>SQ_ICAL.</p> <p>This bit determines if the output clocks will remain enabled or be squelched (disabled) during an internal calibration. See Table 11 on page 25.</p> <p>0: Output clocks enabled during ICAL. 1: Output clocks disabled during ICAL.</p>
3:0	Reserved	Reserved.

Register 4.

Bit	D7	D6	D5	D4	D3	D2	D1	D0
Name	AUTOSEL_REG [1:0]			HIST_DEL [4:0]				
Type	R/W		R	R/W				

Reset value = 0001 0010

Bit	Name	Function
7:6	AUTOSEL_REG [1:0]	AUTOSEL_REG [1:0]. Selects method of input clock selection to be used. 00: Manual (either register or pin controlled, see CKSEL_PIN) 01: Automatic Non-Revertive 10: Automatic Revertive 11: Reserved
5	Reserved	Reserved.
4:0	HIST_DEL [4:0]	HIST_DEL [4:0]. Selects amount of delay to be used in generating the history information used for Digital Hold.

Register 5.

Bit	D7	D6	D5	D4	D3	D2	D1	D0
Name	ICMOS [1:0]							
Type	R/W		R	R	R	R	R	R

Reset value = 1110 1101

Bit	Name	Function
7:6	ICMOS [1:0]	ICMOS [1:0]. When the output buffer is set to CMOS mode, these bits determine the output buffer drive strength. The first number below refers to 3.3 V operation; the second to 1.8 V operation. These values assume CKOUT+ is tied to CKOUT-. 00: 8mA/2mA. 01: 16mA/4mA 10: 24mA/6mA 11: 32mA/8mA
5:0	Reserved	Reserved.

Si5324

Register 6.

Bit	D7	D6	D5	D4	D3	D2	D1	D0
Name			SFOUT2_REG [2:0]			SFOUT1_REG [2:0]		
Type	R	R	R/W			R/W		

Reset value = 0010 1101

Bit	Name	Function
7:6	Reserved	Reserved.
5:3	SFOUT2_REG [2:0]	SFOUT2_REG [2:0]. Controls output signal format and disable for CKOUT2 output buffer. Bypass mode is not supported for CMOS output clocks. 000: Reserved 001: Disable 010: CMOS 011: Low swing LVDS 100: Reserved 101: LVPECL 110: CML 111: LVDS
2:0	SFOUT1_REG [2:0]	SFOUT1_REG [2:0]. Controls output signal format and disable for CKOUT1 output buffer. Bypass mode is not supported for CMOS output clocks. 000: Reserved 001: Disable 010: CMOS 011: Low swing LVDS 100: Reserved 101: LVPECL 110: CML 111: LVDS

Register 7.

Bit	D7	D6	D5	D4	D3	D2	D1	D0
Name						FOSREFSEL [2:0]		
Type	R	R	R	R	R	R/W		

Reset value = 0010 1010

Bit	Name	Function
7:3	Reserved.	Reserved.
2:0	FOSREFSEL [2:0]	FOSREFSEL [2:0]. Selects which input clock is used as the reference frequency for Frequency Off-Set (FOS) alarms. 000: XA/XB (External reference) 001: CKIN1 010: CKIN2 011: Reserved 100: Reserved 101: Reserved 110: Reserved 111: Reserved

Si5324

Register 8.

Bit	D7	D6	D5	D4	D3	D2	D1	D0
Name	HLOG_2[1:0]		HLOG_1[1:0]					
Type	R/W		R/W		R	R	R	R

Reset value = 0000 0000

Bit	Name	Function
7:6	HLOG_2 [1:0]	HLOG_2 [1:0]. 00: Normal operation 01: Holds CKOUT2 output at static logic 0. Entrance and exit from this state will occur without glitches or runt pulses. 10:Holds CKOUT2 output at static logic 1. Entrance and exit from this state will occur without glitches or runt pulses. 11: Reserved
5:4	HLOG_1 [1:0]	HLOG_1 [1:0]. 00: Normal operation 01: Holds CKOUT1 output at static logic 0. Entrance and exit from this state will occur without glitches or runt pulses. 10: Holds CKOUT1 output at static logic 1. Entrance and exit from this state will occur without glitches or runt pulses. 11: Reserved
3:0	Reserved	Reserved.

Register 9.

Bit	D7	D6	D5	D4	D3	D2	D1	D0
Name	HIST_AVG [4:0]							
Type	R/W					R	R	R

Reset value = 1100 0000

Bit	Name	Function
7:3	HIST_AVG [4:0]	HIST_AVG [4:0]. Selects amount of averaging time to be used in generating the history information for Digital Hold.
2:0	Reserved	Reserved.

Register 10.

Bit	D7	D6	D5	D4	D3	D2	D1	D0
Name					DSBL2_REG	DSBL1_REG		
Type	R	R	R	R	R/W	R/W	R	R

Reset value = 0000 0000

Bit	Name	Function
7:4	Reserved	Reserved.
3	DSBL2_REG	DSBL2_REG. This bit controls the powerdown of the CKOUT2 output buffer. If disable mode is selected, the NC2_LS output divider is also powered down. 0: CKOUT2 enabled. 1: CKOUT2 disabled.
2	DSBL1_REG	DSBL1_REG. This bit controls the powerdown of the CKOUT1 output buffer. If disable mode is selected, the NC1_LS output divider is also powered down. 0: CKOUT1 enabled. 1: CKOUT1 disabled.
1:0	Reserved	Reserved.

Register 11.

Bit	D7	D6	D5	D4	D3	D2	D1	D0
Name							PD_CK2	PD_CK1
Type	R	R	R	R	R	R	R/W	R/W

Reset value = 0100 0000

Bit	Name	Function
7:2	Reserved	Reserved.
1	PD_CK2	PD_CK2. This bit controls the powerdown of the CKIN2 input buffer. 0: CKIN2 enabled. 1: CKIN2 disabled.
0	PD_CK1	PD_CK1. This bit controls the powerdown of the CKIN1 input buffer. 0: CKIN1 enabled. 1: CKIN1 disabled.

Si5324

Register 19.

Bit	D7	D6	D5	D4	D3	D2	D1	D0
Name	FOS_EN	FOS_THR [1:0]		VALTIME [1:0]		LOCKT [2:0]		
Type	R/W	R/W		R/W		R/W		

Reset value = 0010 1100

Bit	Name	Function
7	FOS_EN	FOS_EN. Frequency Offset Enable globally disables FOS. See the individual FOS enables (FOSx_EN, register 139). 0: FOS disable 1: FOS enabled by FOSx_EN
6:5	FOS_THR [1:0]	FOS_THR [1:0]. Frequency Offset at which FOS is declared: 00: ± 11 to 12 ppm (Stratum 3/3E compliant, with a Stratum 3/3E used for REFCLK) 01: ± 48 to 49 ppm (SMC) 10: ± 30 ppm (SONET Minimum Clock (SMC), with a Stratum 3/3E used for REFCLK). 11: ± 200 ppm
4:3	VALTIME [1:0]	VALTIME [1:0]. Sets amount of time for input clock to be valid before the associated alarm is removed. 00: 2 ms 01: 100 ms 10: 200 ms 11: 13 seconds
2:0	LOCKT [2:0]	LOCKT [2:0]. Sets retrigger interval for one shot monitoring phase detector output. One shot is triggered by phase slip in DSPLL. Refer to the Family Reference Manual for more details. To minimize lock time, the value 001 for LOCKT is recommended (see “AN803: Lock and Settling Time Considerations for Si5324/27/69/74 Any-Frequency Jitter Attenuating Clock ICs” for additional details). 000: 106 ms 001: 53 ms 010: 26.5 ms 011: 13.3 ms 100: 6.6 ms 101: 3.3 ms 110: 1.66 ms 111: .833 ms

Register 20.

Bit	D7	D6	D5	D4	D3	D2	D1	D0
Name					CK2_BAD_PIN	CK1_BAD_PIN	LOL_PIN	INT_PIN
Type	R	R	R	R	R/W	R/W	R/W	R/W

Reset value = 0011 1110

Bit	Name	Function
7:4	Reserved	Reserved.
3	CK2_BAD_PIN	CK2_BAD_PIN. The CK2_BAD status can be reflected on the C2B output pin. 0: C2B output pin tristated 1: C2B status reflected to output pin
2	CK1_BAD_PIN	CK1_BAD_PIN. The CK1_BAD status can be reflected on the C1B output pin. 0: C1B output pin tristated 1: C1B status reflected to output pin
1	LOL_PIN	LOL_PIN. The LOL_INT status bit can be reflected on the LOL output pin. 0: LOL output pin tristated 1: LOL_INT status reflected to output pin
0	INT_PIN	INT_PIN. Reflects the interrupt status on the INT_C1B output pin. 0: Interrupt status not displayed on INT_C1B output pin. If CK1_BAD_PIN = 0, INT_C1B output pin is tristated. 1: Interrupt status reflected to output pin. Instead, the INT_C1B pin indicates when CKIN1 is bad.

Register 21.

Bit	D7	D6	D5	D4	D3	D2	D1	D0
Name							CK1_ACTV_PIN	CKSEL_PIN
Type	R	R	R	R	R	R	R/W	R/W

Reset value = 1111 1111

Bit	Name	Function
7:2	Reserved	Reserved.
1	CK1_ACTV_PIN	<p>CK1_ACTV_PIN.</p> <p>The CK1_ACTV_REG status bit can be reflected to the CS_CA output pin using the CK1_ACTV_PIN enable function. CK1_ACTV_PIN is of consequence only when pin controlled clock selection is not being used.</p> <p>0: CS_CA output pin tristated.</p> <p>1: Clock Active status reflected to output pin.</p>
0	CKSEL_PIN	<p>CKSEL_PIN.</p> <p>If manual clock selection is being used, clock selection can be controlled via the CKSEL_REG[1:0] register bits or the CS_CA input pin. This bit is only active when AUTOSEL_REG = Manual.</p> <p>0: CS_CA pin is ignored. CKSEL_REG[1:0] register bits control clock selection.</p> <p>1: CS_CA input pin controls clock selection.</p>

Register 22.

Bit	D7	D6	D5	D4	D3	D2	D1	D0
Name					CK_ACTV_POL	CK_BAD_POL	LOL_POL	INT_POL
Type	R	R	R	R	R/W	R/W	R/W	R/W

Reset value = 1101 1111

Bit	Name	Function
7:4	Reserved	Reserved.
3	CK_ACTV_POL	CK_ACTV_POL. Sets the active polarity for the CS_CA signals when reflected on an output pin. 0: Active low 1: Active high
2	CK_BAD_POL	CK_BAD_POL. Sets the active polarity for the INT_C1B and C2B signals when reflected on output pins. 0: Active low 1: Active high
1	LOL_POL	LOL_POL. Sets the active polarity for the LOL status when reflected on an output pin. 0: Active low 1: Active high
0	INT_POL	INT_POL. Sets the active polarity for the interrupt status when reflected on the INT_C1B output pin. 0: Active low 1: Active high

Si5324

Register 23.

Bit	D7	D6	D5	D4	D3	D2	D1	D0
Name						LOS2_MSK	LOS1_MSK	LOSX_MSK
Type	R	R	R	R	R	R/W	R/W	R/W

Reset value = 0001 1111

Bit	Name	Function
7:3	Reserved	Reserved.
2	LOS2_MSK	LOS2_MSK. Determines if a LOS on CKIN2 (LOS2_FLG) is used in the generation of an interrupt. Writes to this register do not change the value held in the LOS2_FLG register. 0: LOS2 alarm triggers active interrupt on INT_C1B output (if INT_PIN=1). 1: LOS2_FLG ignored in generating interrupt output.
1	LOS1_MSK	LOS1_MSK. Determines if a LOS on CKIN1 (LOS1_FLG) is used in the generation of an interrupt. Writes to this register do not change the value held in the LOS1_FLG register. 0: LOS1 alarm triggers active interrupt on INT_C1B output (if INT_PIN=1). 1: LOS1_FLG ignored in generating interrupt output.
0	LOSX_MSK	LOSX_MSK. Determines if a LOS on XA/XB(LOSX_FLG) is used in the generation of an interrupt. Writes to this register do not change the value held in the LOSX_FLG register. 0: LOSX alarm triggers active interrupt on INT_C1B output (if INT_PIN=1). 1: LOSX_FLG ignored in generating interrupt output.

Register 24.

Bit	D7	D6	D5	D4	D3	D2	D1	D0
Name						FOS2_MSK	FOS1_MSK	LOL_MSK
Type	R	R	R	R	R	R/W	R/W	R/W

Reset value = 0011 1111

Bit	Name	Function
7:3	Reserved	Reserved.
2	FOS2_MSK	FOS2_MSK. Determines if the FOS2_FLG is used to in the generation of an interrupt. Writes to this register do not change the value held in the FOS2_FLG register. 0: FOS2 alarm triggers active interrupt on INT_C1B output (if INT_PIN=1). 1: FOS2_FLG ignored in generating interrupt output.
1	FOS1_MSK	FOS1_MSK. Determines if the FOS1_FLG is used in the generation of an interrupt. Writes to this register do not change the value held in the FOS1_FLG register. 0: FOS1 alarm triggers active interrupt on INT_C1B output (if INT_PIN=1). 1: FOS1_FLG ignored in generating interrupt output.
0	LOL_MSK	LOL_MSK. Determines if the LOL_FLG is used in the generation of an interrupt. Writes to this register do not change the value held in the LOL_FLG register. 0: LOL alarm triggers active interrupt on INT_C1B output (if INT_PIN=1). 1: LOL_FLG ignored in generating interrupt output.

Si5324

Register 25.

Bit	D7	D6	D5	D4	D3	D2	D1	D0
Name	N1_HS [2:0]							
Type	R/W			R	R	R	R	R

Reset value = 0010 0000

Bit	Name	Function
7:5	N1_HS [2:0]	N1_HS [2:0]. Sets value for N1 high speed divider which drives NCn_LS (n = 1 to 2) low-speed divider. 000: N1= 4 001: N1= 5 010: N1=6 011: N1= 7 100: N1= 8 101: N1= 9 110: N1= 10 111: N1= 11
4:0	Reserved	Reserved.

Register 31.

Bit	D7	D6	D5	D4	D3	D2	D1	D0
Name					NC1_LS [19:16]			
Type	R	R	R	R	R/W			

Reset value = 0000 0000

Bit	Name	Function
7:4	Reserved	Reserved.
3:0	NC1_LS [19:16]	NC1_LS [19:16]. Sets value for NC1 low-speed divider, which drives CKOUT1 output. Must be 0 or odd. 00000000000000000000 = 1 00000000000000000001 = 2 00000000000000000011 = 4 00000000000000000101 = 6 ... 11111111111111111111=2^20 Valid divider values=[1, 2, 4, 6, ..., 2^20]

Register 32.

Bit	D7	D6	D5	D4	D3	D2	D1	D0
Name	NC1_LS [15:8]							
Type	R/W							

Reset value = 0000 0000

Bit	Name	Function
7:0	NC1_LS [15:8]	NC1_LS [15:8]. Sets value for NC1 low-speed divider, which drives CKOUT1 output. Must be 0 or odd. 00000000000000000000 = 1 00000000000000000001 = 2 00000000000000000011 = 4 00000000000000000101 = 6 ... 11111111111111111111=2 ²⁰ Valid divider values=[1, 2, 4, 6, ..., 2 ²⁰]

Register 33.

Bit	D7	D6	D5	D4	D3	D2	D1	D0
Name	NC1_LS [7:0]							
Type	R/W							

Reset value = 0011 0001

Bit	Name	Function
7:0	NC1_LS [19:0]	NC1_LS [7:0]. Sets value for NC1 low-speed divider, which drives CKOUT1 output. Must be 0 or odd. 00000000000000000000 = 1 00000000000000000001 = 2 00000000000000000011 = 4 00000000000000000101 = 6 ... 11111111111111111111=2 ²⁰ Valid divider values=[1, 2, 4, 6, ..., 2 ²⁰]

Si5324

Register 34.

Bit	D7	D6	D5	D4	D3	D2	D1	D0
Name	NC2_LS [19:16]							
Type	R	R	R	R				R/W

Reset value = 0000 0000

Bit	Name	Function
7:4	Reserved	Reserved.
3:0	NC2_LS [19:16]	NC2_LS [19:16]. Sets value for NC2 low-speed divider, which drives CKOUT2 output. Must be 0 or odd. 00000000000000000000=1 00000000000000000001=2 00000000000000000011=4 00000000000000000101=6 ... 11111111111111111111=2^20 Valid divider values=[1, 2, 4, 6, ..., 2^20]

Register 35.

Bit	D7	D6	D5	D4	D3	D2	D1	D0
Name	NC2_LS [15:8]							
Type	R/W							

Reset value = 0000 0000

Bit	Name	Function
7:0	NC2_LS [15:8]	NC2_LS [15:8]. Sets value for NC2 low-speed divider, which drives CKOUT2 output. Must be 0 or odd. 00000000000000000000 = 1 00000000000000000001 = 2 00000000000000000011 = 4 00000000000000000101 = 6 ... 11111111111111111111=2^20 Valid divider values=[1, 2, 4, 6, ..., 2^20]

Register 36.

Bit	D7	D6	D5	D4	D3	D2	D1	D0
Name	NC2_LS [7:0]							
Type	R/W							

Reset value = 0011 0001

Bit	Name	Function
7:0	NC2_LS [7:0]	<p>NC2_LS [7:0]. Sets value for NC2 low-speed divider, which drives CKOUT2 output. Must be 0 or odd. 00000000000000000000 = 1 00000000000000000001 = 2 00000000000000000011 = 4 00000000000000000101 = 6 ... 11111111111111111111 = 2^{20} Valid divider values = [1, 2, 4, 6, ..., 2^{20}]</p>

Si5324

Register 40.

Bit	D7	D6	D5	D4	D3	D2	D1	D0
Name	N2_HS [2:0]				N2_LS [19:16]			
Type	R/W			R		R/W		

Reset value = 1100 0000

Bit	Name	Function
7:5	N2_HS [2:0]	N2_HS [2:0]. Sets value for N2 high speed divider which drives N2LS low-speed divider. 000: 4 001: 5 010: 6 011: 7 100: 8 101: 9 110: 10 111: 11
4	Reserved	Reserved.
3:0	N2_LS [19:16]	N2_LS [19:16]. Sets value for N2 low-speed divider, which drives phase detector. 00000000000000000001 = 2 00000000000000000011 = 4 00000000000000000101 = 6 ... 11111111111111111111 = 2^{20} Valid divider values = [2, 4, 6, ..., 2^{20}]

Register 41.

Bit	D7	D6	D5	D4	D3	D2	D1	D0
Name	N2_LS [15:8]							
Type	R/W							

Reset value = 0000 0000

Bit	Name	Function
7:0	N2_LS [15:8]	<p>N2_LS [15:8]. Sets value for N2 low-speed divider, which drives phase detector. 00000000000000000001 = 2 00000000000000000011 = 4 00000000000000000101 = 6 ... 11111111111111111111 = 2^{20} Valid divider values = [2, 4, 6, ..., 2^{20}]</p>

Register 42.

Bit	D7	D6	D5	D4	D3	D2	D1	D0
Name	N2_LS [7:0]							
Type	R/W							

Reset value = 1111 1001

Bit	Name	Function
7:0	N2_LS [7:0]	<p>N2_LS [7:0]. Sets value for N2 low-speed divider, which drives phase detector. 00000000000000000001 = 2 00000000000000000011 = 4 00000000000000000101 = 6 ... 11111111111111111111 = 2^{20} Valid divider values = [2, 4, 6, ..., 2^{20}]</p>

Si5324

Register 43.

Bit	D7	D6	D5	D4	D3	D2	D1	D0
Name	N31 [18:16]							
Type	R	R	R	R	R	R/W		

Reset value = 0000 0000

Bit	Name	Function
7:3	Reserved	Reserved.
2:0	N31 [18:16]	N31 [18:16]. Sets value for input divider for CKIN1. 00000000000000000000 = 1 00000000000000000001 = 2 00000000000000000010 = 3 ... 11111111111111111111 = 2^{19} Valid divider values = [1, 2, 3, ..., 2^{19}]

Register 44.

Bit	D7	D6	D5	D4	D3	D2	D1	D0
Name	N31_[15:8]							
Type	R/W							

Reset value = 0000 0000

Bit	Name	Function
7:0	N31_[15:8]	N31_[15:8]. Sets value for input divider for CKIN1. 00000000000000000000 = 1 00000000000000000001 = 2 00000000000000000010 = 3 ... 11111111111111111111 = 2^{19} Valid divider values = [1, 2, 3, ..., 2^{19}]

Register 45.

Bit	D7	D6	D5	D4	D3	D2	D1	D0
Name	N31_[7:0]							
Type	R/W							

Reset value = 0000 1001

Bit	Name	Function
7:0	N31_[7:0]	N31_[7:0]. Sets value for input divider for CKIN1. 00000000000000000000 = 1 00000000000000000001 = 2 00000000000000000010 = 3 ... 11111111111111111111 = 2^{19} Valid divider values = [1, 2, 3, ..., 2^{19}]

Register 46.

Bit	D7	D6	D5	D4	D3	D2	D1	D0
Name							N32_[18:16]	
Type	R	R	R	R	R		R/W	

Reset value = 0000 0000

Bit	Name	Function
7:3	Reserved	Reserved.
2:0	N32_[18:16]	N32_[18:16]. Sets value for input divider for CKIN2. 00000000000000000000 = 1 00000000000000000001 = 2 00000000000000000010 = 3 ... 11111111111111111111 = 2^{19} Valid divider values = [1, 2, 3, ..., 2^{19}]

Si5324

Register 47.

Bit	D7	D6	D5	D4	D3	D2	D1	D0
Name	N32_[15:8]							
Type	R/W							

Reset value = 0000 0000

Bit	Name	Function
7:0	N32_[15:8]	<p>N32_[15:8]. Sets value for input divider for CKIN2. 00000000000000000000 = 1 00000000000000000001 = 2 00000000000000000010 = 3 ... 11111111111111111111 = 2^{19} Valid divider values = [1, 2, 3, ..., 2^{19}]</p>

Register 48.

Bit	D7	D6	D5	D4	D3	D2	D1	D0
Name	N32_[7:0]							
Type	R/W							

Reset value = 0000 1001

Bit	Name	Function
7:0	N32_[7:0]	<p>N32_[7:0]. Sets value for input divider for CKIN2. 00000000000000000000 = 1 00000000000000000001 = 2 00000000000000000010 = 3 ... 11111111111111111111 = 2^{19} Valid divider values = [1, 2, 3, ..., 2^{19}]</p>

Register 55.

Bit	D7	D6	D5	D4	D3	D2	D1	D0
Name			CLKIN2RATE_[2:0]			CLKIN1RATE[2:0]		
Type	R	R	R/W			R/W		

Reset value = 0000 0000

Bit	Name	Function
7:6	Reserved	Reserved.
5:3	CLKIN2RATE[2:0]	CLKIN2RATE_[2:0]. CKINn frequency selection for FOS alarm monitoring. 000: 10–27 MHz 001: 25–54 MHz 002: 50–105 MHz 003: 95–215 MHz 004: 190–435 MHz 005: 375–710 MHz 006: Reserved 007: Reserved
2:0	CLKIN1RATE [2:0]	CLKIN1RATE[2:0]. CKINn frequency selection for FOS alarm monitoring. 000: 10–27 MHz 001: 25–54 MHz 002: 50–105 MHz 003: 95–215 MHz 004: 190–435 MHz 005: 375–710 MHz 006: Reserved 007: Reserved

Si5324

Register 128.

Bit	D7	D6	D5	D4	D3	D2	D1	D0
Name							CK2_ACTV_REG	CK1_ACTV_REG
Type	R	R	R	R	R	R	R	R

Reset value = 0010 0000

Bit	Name	Function
7:2	Reserved	Reserved.
1	CK2_ACTV_REG	CK2_ACTV_REG. Indicates if CKIN2 is currently the active clock for the PLL input. 0: CKIN2 is not the active input clock. Either it is not selected or LOS2_INT is 1. 1: CKIN2 is the active input clock.
0	CK1_ACTV_REG	CK1_ACTV_REG. Indicates if CKIN1 is currently the active clock for the PLL input. 0: CKIN1 is not the active input clock. Either it is not selected or LOS1_INT is 1. 1: CKIN1 is the active input clock.

Register 129.

Bit	D7	D6	D5	D4	D3	D2	D1	D0
Name						LOS2_INT	LOS1_INT	LOSX_INT
Type	R	R	R	R	R	R	R	R

Reset value = 0000 0110

Bit	Name	Function
7:3	Reserved	Reserved.
2	LOS2_INT	LOS2_INT. Indicates the LOS status on CKIN2. 0: Normal operation. 1: Internal loss-of-signal alarm on CKIN2 input.
1	LOS1_INT	LOS1_INT. Indicates the LOS status on CKIN1. 0: Normal operation. 1: Internal loss-of-signal alarm on CKIN1 input.
0	LOSX_INT	LOSX_INT. Indicates the LOS status of the external reference on the XA/XB pins. 0: Normal operation. 1: Internal loss-of-signal alarm on XA/XB reference clock input.

Register 130.

Bit	D7	D6	D5	D4	D3	D2	D1	D0
Name		DIGHOLDVALID				FOS2_INT	FOS1_INT	LOL_INT
Type	R	R	R	R	R	R	R	R

Reset value = 0000 0001

Bit	Name	Function
7	Reserved	Reserved.
6	DIGHOLDVALID	Digital Hold Valid. Indicates if the digital hold circuit has enough samples of a valid clock to meet digital hold specifications. 0: Indicates digital hold history registers have not been filled. The digital hold output frequency may not meet specifications. 1: Indicates digital hold history registers have been filled. The digital hold output frequency is valid.
5:3	Reserved	Reserved.
2	FOS2_INT	CKIN2 Frequency Offset Status. 0: Normal operation. 1: Internal frequency offset alarm on CKIN2 input.
1	FOS1_INT	CKIN1 Frequency Offset Status. 0: Normal operation. 1: Internal frequency offset alarm on CKIN1 input.
0	LOL_INT	PLL Loss of Lock Status. 0: PLL locked. 1: PLL unlocked.

Si5324

Register 131.

Bit	D7	D6	D5	D4	D3	D2	D1	D0
Name						LOS2_FLG	LOS1_FLG	LOSX_FLG
Type	R	R	R	R	R	R/W	R/W	R/W

Reset value = 0001 1111

Bit	Name	Function
7:3	Reserved	Reserved.
2	LOS2_FLG	CKIN2 Loss-of-Signal Flag. 0: Normal operation. 1: Held version of LOS2_INT. Generates active output interrupt if output interrupt pin is enabled (INT_PIN = 1) and if not masked by LOS2_MSK bit. Flag cleared by writing 0 to this bit.
1	LOS1_FLG	CKIN1 Loss-of-Signal Flag. 0: Normal operation 1: Held version of LOS1_INT. Generates active output interrupt if output interrupt pin is enabled (INT_PIN = 1) and if not masked by LOS1_MSK bit. Flag cleared by writing 0 to this bit.
0	LOSX_FLG	External Reference (signal on pins XA/XB) Loss-of-Signal Flag. 0: Normal operation 1: Held version of LOSX_INT. Generates active output interrupt if output interrupt pin is enabled (INT_PIN = 1) and if not masked by LOSX_MSK bit. Flag cleared by writing 0 to this bit.

Register 132.

Bit	D7	D6	D5	D4	D3	D2	D1	D0
Name					FOS2_FLG	FOS1_FLG	LOL_FLG	
Type	R	R	R	R	R/W	R/W	R/W	R

Reset value = 0000 0010

Bit	Name	Function
7:4	Reserved	Reserved.
3	FOS2_FLG	CLKIN_2 Frequency Offset Flag. 0: Normal operation. 1: Held version of FOS2_INT. Generates active output interrupt if output interrupt pin is enabled (INT_PIN = 1) and if not masked by FOS2_MSK bit. Flag cleared by writing 0 to this bit.
2	FOS1_FLG	CLKIN_1 Frequency Offset Flag. 0: Normal operation 1: Held version of FOS1_INT. Generates active output interrupt if output interrupt pin is enabled (INT_PIN = 1) and if not masked by FOS1_MSK bit. Flag cleared by writing 0 to this bit.
1	LOL_FLG	PLL Loss of Lock Flag. 0: PLL locked 1: Held version of LOL_INT. Generates active output interrupt if output interrupt pin is enabled (INT_PIN = 1) and if not masked by LOL_MSK bit. Flag cleared by writing 0 to this bit.
0	Reserved	Reserved.

Si5324

Register 134.

Bit	D7	D6	D5	D4	D3	D2	D1	D0
Name	PARTNUM_RO [11:4]							
Type	R							

Reset value = 0000 0001

Bit	Name	Function
7:0	PARTNUM_RO [11:0]	Device ID (1 of 2). 0000 0001 1000: Si5324 Others Reserved

Register 135.

Bit	D7	D6	D5	D4	D3	D2	D1	D0
Name	PARTNUM_RO [3:0]				REVID_RO [3:0]			
Type	R				R			

Reset value = 1000 0010

Bit	Name	Function
7:4	PARTNUM_RO [11:0]	Device ID (2 of 2). 0000 0001 1000: Si5324 Others Reserved
3:0	REVID_RO [3:0]	Indicates Revision Number of Device. 0010: Revision C Others Reserved.

Register 136.

Bit	D7	D6	D5	D4	D3	D2	D1	D0
Name	RST_REG	ICAL						
Type	R/W	R/W	R	R	R	R	R	R

Reset value = 0000 0000

Bit	Name	Function
7	RST_REG	<p>Internal Reset (Same as Pin Reset).</p> <p>Note: The I²C (or SPI) port may not be accessed until 10 ms after RST_REG is asserted.</p> <p>0: Normal operation.</p> <p>1: Reset of all internal logic. Outputs disabled or tristated during reset.</p>
6	ICAL	<p>Start an Internal Calibration Sequence.</p> <p>For proper operation, the device must go through an internal calibration sequence. ICAL is a self-clearing bit. Writing a one to this location initiates an ICAL. The calibration is complete once the LOL alarm goes low. A valid stable clock (within 100 ppm) must be present to begin ICAL.</p> <p>Note: Any divider, CLKINn_RATE or BWSEL_REG changes require an ICAL to take effect.</p> <p>0: Normal operation.</p> <p>1: Writing a "1" initiates internal self-calibration. Upon completion of internal self-calibration, LOL will go low.</p>
5:0	Reserved	Reserved.

Si5324

Register 137.

Bit	D7	D6	D5	D4	D3	D2	D1	D0
Name								FASTLOCK
Type	R	R	R	R	R	R	R	R/W

Reset value = 0000 0000

Bit	Name	Function
7:1	Reserved	Do not modify.
0	FASTLOCK	This bit must be set to 1 to enable FASTLOCK. This improves initial lock time by dynamically changing the loop bandwidth.

Register 138.

Bit	D7	D6	D5	D4	D3	D2	D1	D0
Name							LOS2_EN [1:1]	LOS1_EN [1:1]
Type	R	R	R	R	R	R	R/W	R/W

Reset value = 0000 1111

Bit	Name	Function
7:2	Reserved	Reserved.
1	LOS2_EN [1:0]	Enable CKIN2 LOS Monitoring on the Specified Input (2 of 2). Note: LOS2_EN is split between two registers. 00: Disable LOS monitoring. 01: Reserved. 10: Enable LOSA monitoring. 11: Enable LOS monitoring. LOSA is a slower and less sensitive version of LOS. See the Family Reference Manual for details.
0	LOS1_EN [1:0]	Enable CKIN1 LOS Monitoring on the Specified Input (1 of 2). Note: LOS1_EN is split between two registers. 00: Disable LOS monitoring. 01: Reserved. 10: Enable LOSA monitoring. 11: Enable LOS monitoring. LOSA is a slower and less sensitive version of LOS. See the Family Reference Manual for details.

Register 139.

Bit	D7	D6	D5	D4	D3	D2	D1	D0
Name			LOS2_EN [0:0]	LOS1_EN [0:0]			FOS2_EN	FOS1_EN
Type	R	R	R/W	R/W	R	R	R/W	R/W

Reset value = 1111 1111

Bit	Name	Function
7:6	Reserved	Reserved.
5	LOS2_EN [1:0]	Enable CKIN2 LOS Monitoring on the Specified Input (2 of 2). Note: LOS2_EN is split between two registers. 00: Disable LOS monitoring. 01: Reserved. 10: Enable LOSA monitoring. 11: Enable LOS monitoring. LOSA is a slower and less sensitive version of LOS. See the family reference manual for details.
4	LOS_EN [1:0]	Enable CKIN1 LOS Monitoring on the Specified Input (1 of 2). Note: LOS1_EN is split between two registers. 00: Disable LOS monitoring. 01: Reserved. 10: Enable LOSA monitoring. 11: Enable LOS monitoring. LOSA is a slower and less sensitive version of LOS. See the family reference manual for details.
3:2	Reserved	Reserved.
1	FOS2_EN	Enables FOS on a Per Channel Basis. 0: Disable FOS monitoring. 1: Enable FOS monitoring.
0	FOS1_EN	Enables FOS on a Per Channel Basis. 0: Disable FOS monitoring. 1: Enable FOS monitoring.

Si5324

Register 142.

Bit	D7	D6	D5	D4	D3	D2	D1	D0
Name	INDEPENDENTSKEW1 [7:0]							
Type	R/W							

Reset value = 0000 0000

Bit	Name	Function
7:0	INDEPENDENTSKEW1 [7:0]	INDEPENDENTSKEW1. 8 bit field that represents a twos complement of the phase offset in terms of clocks from the high speed output divider. Default = 0.

Register 143.

Bit	D7	D6	D5	D4	D3	D2	D1	D0
Name	INDEPENDENTSKEW2 [7:0]							
Type	R/W							

Reset value = 0000 0000

Bit	Name	Function
7:0	INDEPENDENTSKEW2 [7:0]	INDEPENDENTSKEW2. 8 bit field that represents a twos complement of the phase offset in terms of clocks from the high speed output divider. Default = 0.

5.1. ICAL

The device's registers must be configured for the intended applications. After the part is configured, the part must perform a calibration procedure when there is a stable clock on the selected CLKINn input. The calibration process is triggered by writing a "1" to bit D6 in register 136. See the Family Reference Manual for details. In addition, after a successful calibration operation, changing any of the Registers indicated in Table 12 requires that a calibration be performed again by the same procedure (writing a "1" to bit D6 in register 136).

Table 12. ICAL-Sensitive Registers

Address	Register
0	BYPASS_REG
0	CKOUT_ALWAYS_ON
1	CK_PRIOR1
1	CK_PRIOR2
2	BWSEL_REG
4	HIST_DEL
5	ICMOS
7	FOSREFSEL
9	HIST_AVG
10	DSBL1_REG
10	DSBL2_REG
11	PD_CK1
11	PD_CK2
19	FOS_EN
19	FOS_THR
19	LOCKT
19	VALTIME
25	N1HS
31	NC1_LS
34	NC2_LS
40	N2_HS
40	N2_LS
43	N31
46	N32
55	CLKIN1RATE
55	CLKIN2RATE

6. Pin Descriptions

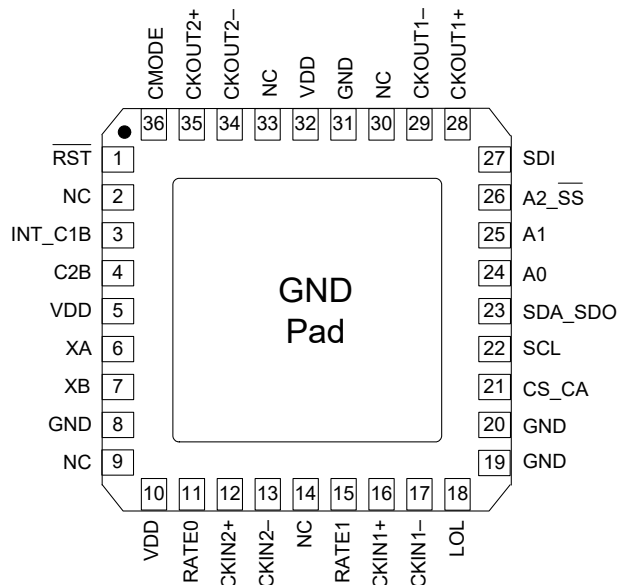

Pin #	Pin Name	I/O	Signal Level	Description
1	$\overline{\text{RST}}$	I	LVCMOS	External Reset. Active low input that performs external hardware reset of device. Resets all internal logic to a known state and forces the device registers to their default value. Clock outputs are disabled during reset. The part must be programmed after a reset or power-on to get a clock output. See Family Reference Manual for details. This pin has a weak pull-up.
2, 9, 14, 30, 33	NC			No Connection. Leave floating. Make no external connections to this pin for normal operation.
3	INT_C1B	O	LVCMOS	Interrupt/CKIN1 Invalid Indicator. This pin functions as a device interrupt output or an alarm output for CKIN1. If used as an interrupt output, <i>INT_PIN</i> must be set to 1. The pin functions as a maskable interrupt output with active polarity controlled by the <i>INT_POL</i> register bit. If used as an alarm output, the pin functions as a LOS (and optionally FOS) alarm indicator for CKIN1. Set <i>CK1_BAD_PIN</i> = 1 and <i>INT_PIN</i> = 0. 0 = CKIN1 present. 1 = LOS (FOS) on CKIN1. The active polarity is controlled by <i>CK_BAD_POL</i> . If no function is selected, the pin tristates.
Note: Internal register names are indicated by underlined italics, e.g., <i>INT_PIN</i> . See Si5324 Register Map.				

Pin #	Pin Name	I/O	Signal Level	Description
4	C2B	O	LVC MOS	CKIN2 Invalid Indicator. This pin functions as a LOS (and optionally FOS) alarm indicator for CKIN2 if CK2_BAD_PIN = 1. 0 = CKIN2 present. 1 = LOS (FOS) on CKIN2. The active polarity can be changed by CK_BAD_POL. If CK2_BAD_PIN = 0, the pin tristates.
5, 10, 32	V _{DD}	V _{DD}	Supply	Supply. The device operates from a 1.8, 2.5, or 3.3 V supply. Bypass capacitors should be associated with the following V _{DD} pins: 5 0.1 μF 10 0.1 μF 32 0.1 μF A 1.0 μF should also be placed as close to the device as is practical.
7 6	XB XA	I	Analog	External Crystal or Reference Clock. External crystal should be connected to these pins to use internal oscillator based reference. Refer to Family Reference Manual for interfacing to an external reference. External reference must be from a high-quality clock source (TCXO, OCXO). Frequency of crystal or external clock is set by RATE[1:0] pins.
8, 31, 20, 19	GND	GND	Supply	Ground. Must be connected to system ground. Minimize the ground path impedance for optimal performance of this device. Grounding these pins does not eliminate the requirement to ground the GND PAD on the bottom of the package.
11 15	RATE0 RATE1	I	3-Level	External Crystal or Reference Clock Rate. Three level inputs that select the type and rate of external crystal or reference clock to be applied to the XA/XB port. Refer to the Family Reference Manual for settings. These pins have both a weak pull-up and a weak pull-down; they default to M. L setting corresponds to ground. M setting corresponds to V _{DD} /2. H setting corresponds to V _{DD} . Some designs may require an external resistor voltage divider when driven by an active device that will tri-state.
16 17	CKIN1+ CKIN1-	I	Multi	Clock Input 1. Differential input clock. This input can also be driven with a single-ended signal. Input frequency range is 2 kHz to 710 MHz.
12 13	CKIN2+ CKIN2-	I	Multi	Clock Input 2. Differential input clock. This input can also be driven with a single-ended signal. Input frequency range is 2 kHz to 710 MHz.
Note: Internal register names are indicated by underlined italics, e.g., <i>INT_PIN</i> . See Si5324 Register Map.				

Si5324

Pin #	Pin Name	I/O	Signal Level	Description
18	LOL	O	LVC MOS	<p>PLL Loss of Lock Indicator.</p> <p>This pin functions as the active high PLL loss of lock indicator if the <i>LOL_PIN</i> register bit is set to 1.</p> <p>0 = PLL locked. 1 = PLL unlocked.</p> <p>If <i>LOL_PIN</i> = 0, this pin will tristate. Active polarity is controlled by the <i>LOL_POL</i> bit. The PLL lock status will always be reflected in the <i>LOL_INT</i> read only register bit (see “AN803: Lock and Settling Time Considerations for Si5324/27/69/74 Any-Frequency Jitter Attenuating Clock ICs” for additional details).</p>
21	CS_CA	I/O	LVC MOS	<p>Input Clock Select/Active Clock Indicator.</p> <p>Input: In manual clock selection mode, this pin functions as the manual input clock selector if the <i>CKSEL_PIN</i> is set to 1.</p> <p>0 = Select CKIN1. 1 = Select CKIN2.</p> <p>If <i>CKSEL_PIN</i> = 0, the <i>CKSEL_REG</i> register bit controls this function and this input tristates. If configured for input, must be tied high or low.</p> <p>Output: In automatic clock selection mode, this pin indicates which of the two input clocks is currently the active clock. If alarms exist on both clocks, <i>CK_ACTV</i> will indicate the last active clock that was used before entering the digital hold state. The <i>CK_ACTV_PIN</i> register bit must be set to 1 to reflect the active clock status to the <i>CK_ACTV</i> output pin.</p> <p>0 = CKIN1 active input clock. 1 = CKIN2 active input clock.</p> <p>If <i>CK_ACTV_PIN</i> = 0, this pin will tristate. The <i>CK_ACTV</i> status will always be reflected in the <i>CK_ACTV_REG</i> read only register bit.</p>
22	SCL	I	LVC MOS	<p>Serial Clock.</p> <p>This pin functions as the serial clock input for both SPI and I²C modes.</p> <p>This pin has a weak pull-down.</p>
23	SDA_SDO	I/O	LVC MOS	<p>Serial Data.</p> <p>In I²C control mode (CMODE = 0), this pin functions as the bidirectional serial data port.</p> <p>In SPI control mode (CMODE = 1), this pin functions as the serial data output.</p>
25 24	A1 A0	I	LVC MOS	<p>Serial Port Address.</p> <p>In I²C control mode (CMODE = 0), these pins function as hardware controlled address bits. The I²C address is 1101 [A2] [A1] [A0].</p> <p>In SPI control mode (CMODE = 1), these pins are ignored.</p> <p>These pins have a weak pull-down.</p>
<p>Note: Internal register names are indicated by underlined italics, e.g., <i>INT_PIN</i>. See Si5324 Register Map.</p>				

Pin #	Pin Name	I/O	Signal Level	Description
26	A2_SS	I	LVC MOS	<p>Serial Port Address/Slave Select.</p> <p>In I²C control mode (CMODE = 0), this pin functions as a hardware controlled address bit [A2].</p> <p>In SPI control mode (CMODE = 1), this pin functions as the slave select input.</p> <p>This pin has a weak pull-down.</p>
27	SDI	I	LVC MOS	<p>Serial Data In.</p> <p>In I²C control mode (CMODE = 0), this pin is ignored.</p> <p>In SPI control mode (CMODE = 1), this pin functions as the serial data input.</p> <p>This pin has a weak pull-down.</p>
29 28	CKOUT1– CKOUT1+	O	Multi	<p>Output Clock 1.</p> <p>Differential output clock with a frequency range of 8 kHz to 1.4175 GHz. Output signal format is selected by <i>SFOUT1_REG</i> register bits. Output is differential for LVPECL, LVDS, and CML compatible modes. For CMOS format, both output pins drive identical single-ended clock outputs.</p>
34 35	CKOUT2– CKOUT2+	O	Multi	<p>Output Clock 2.</p> <p>Differential output clock with a frequency range of 8 kHz to 1.4175 GHz. Output signal format is selected by <i>SFOUT2_REG</i> register bits. Output is differential for LVPECL, LVDS, and CML compatible modes. For CMOS format, both output pins drive identical single-ended clock outputs.</p>
36	CMODE	I	LVC MOS	<p>Control Mode.</p> <p>Selects I²C or SPI control mode for the Si5324.</p> <p>0 = I²C Control Mode</p> <p>1 = SPI Control Mode</p> <p>This pin must not be NC. Tie either high or low.</p>
GND PAD	GND	GND	Supply	<p>Ground Pad.</p> <p>The ground pad must provide a low thermal and electrical impedance to a ground plane.</p>
<p>Note: Internal register names are indicated by underlined italics, e.g., <i>INT_PIN</i>. See Si5324 Register Map.</p>				

Si5324

7. Ordering Guide

Ordering Part Number ¹	Output Clock Frequency Range	Package	ROHS6, Pb-Free	Temperature Range
Si5324A-C-GM ²	2 kHz–945 MHz 970–1134 MHz 1.213–1.417 GHz	36-Lead 6 x 6 mm QFN	Yes	–40 to 85 °C
Si5324B-C-GM ²	2 kHz–808 MHz	36-Lead 6 x 6 mm QFN	Yes	–40 to 85 °C
Si5324C-C-GM ²	2 kHz–346 MHz	36-Lead 6 x 6 mm QFN	Yes	–40 to 85 °C
Si5324D-C-GM ²	2 kHz–150 MHz	36-Lead 6 x 6 mm QFN	Yes	–40 to 85 °C
Si5324E-C-GM ³	2 kHz–945 MHz 970–1134 MHz 1.213–1.417 GHz	36-Lead 6 x 6 mm QFN	Yes	–40 to 85 °C

Notes:

1. Add an R at the end of the device to denote tape and reel options.
2. These OPNs are recommended for all new designs. Refer to AN803 for more information.
3. This OPN is intended for use in legacy designs in which the Si5324 device must retain the original lock time behavior as described in AN803 and Product Bulletin (PB-1312191): “Si5324, Si5374, Si5374 Loss of Lock (LOL) Time Behavior: New Applications Note and Ordering Options”.

Table 13. Product Selection Guide

Part Number	Control	Number of Inputs and Outputs	Input Frequency (MHz)*	Output Frequency (MHz)*	RMS Phase Jitter (12 kHz–20 MHz)	PLL Bandwidth	Hitless Switching	Free Run Mode	Package
Si5315	Pin	1PLL, 2 2	0.008–644	0.008–644	0.45 ps	60 Hz to 8 kHz	•		6x6 mm 36-QFN
Si5316	Pin	1PLL, 2 1	19–710	19–710	0.3 ps	60 Hz to 8 kHz			6x6 mm 36-QFN
Si5317	Pin	1PLL, 1 2	1–710	1–710	0.3 ps	60 Hz to 8 kHz			6x6 mm 36-QFN
Si5319	I ² C/SPI	1PLL, 1 1	0.002–710	0.002–1417	0.3 ps	60 Hz to 8 kHz		•	6x6 mm 36-QFN
Si5323	Pin	1PLL, 2 2	0.008–707	0.008–1050	0.3 ps	60 Hz to 8 kHz	•		6x6 mm 36-QFN
Si5324	I ² C/SPI	1PLL, 2 2	0.002–710	0.002–1417	0.3 ps	4 Hz to 525 Hz	•	•	6x6 mm 36-QFN
Si5326	I ² C/SPI	1PLL, 2 2	0.002–710	0.002–1417	0.3 ps	60 Hz to 8 kHz	•	•	6x6 mm 36-QFN
Si5327	I ² C/SPI	1PLL, 2 2	0.002–710	0.002–808	0.5 ps	60 Hz to 8 kHz	•	•	6x6 mm 36-QFN
Si5366	Pin	1PLL, 4 5	0.008–707	0.008–1050	0.3 ps	60 Hz to 8 kHz	•		14x14 mm 100-TQFP
Si5368	I ² C/SPI	1PLL, 4 5	0.002–710	0.002–1417	0.3 ps	60 Hz to 8 kHz	•	•	14x14 mm 100-TQFP
Si5369	I ² C/SPI	1PLL, 4 5	0.002–710	0.002–1417	0.3 ps	4 Hz to 525 Hz	•	•	14x14 mm 100-TQFP
Si5374	I ² C	4PLL, 8 8	0.002–710	0.002–808	0.4 ps	4 Hz to 525 Hz	•	•	10x10 mm 80-BGA
Si5375	I ² C	4PLL, 4 4	0.002–710	0.002–808	0.4 ps	60 Hz to 8 kHz	•	•	10x10 mm 80-BGA

***Note:** Maximum input and output rates may be limited by speed rating of device. See each device's data sheet for ordering information.

Table 14. Product Selection Guide (Si5322/25/65/67)

Device	Clock Inputs	Clock Outputs	µP Control	Max Input Freq (MHz) ¹	Max Output Frequency (MHz)	Jitter Generation (12 kHz – 20 MHz)	LOS	Hitless Switching	FOS Alarm	LOL Alarm	FSYNC Realignment	36 Lead 6 mm x 6 mm QFN	100 Lead 14 x 14 mm TQFP	1.8, 2.5, 3.3 V Operation	1.8, 2.5 V Operation
Low Jitter Precision Clock Multipliers (Wideband)															
Si5322	2	2		707	1050	0.6 ps rms typ	•					•		•	
Si5325	2	2	•	710	1400	0.6 ps rms typ	•		•			•		•	
Si5365	4	5		707	1050	0.6 ps rms typ	•		•				•		•
Si5367	4	5	•	710	1400	0.6 ps rms typ	•		•				•		•
Notes:															
1. Maximum input and output rates may be limited by speed rating of device. See each device's data sheet for ordering information.															
2. Requires external low-cost, fixed frequency 3rd overtone 114.285 MHz crystal or reference clock.															

8. Package Outline: 36-Pin QFN

Figure 9 illustrates the package details for the Si5324. Table 15 lists the values for the dimensions shown in the illustration.

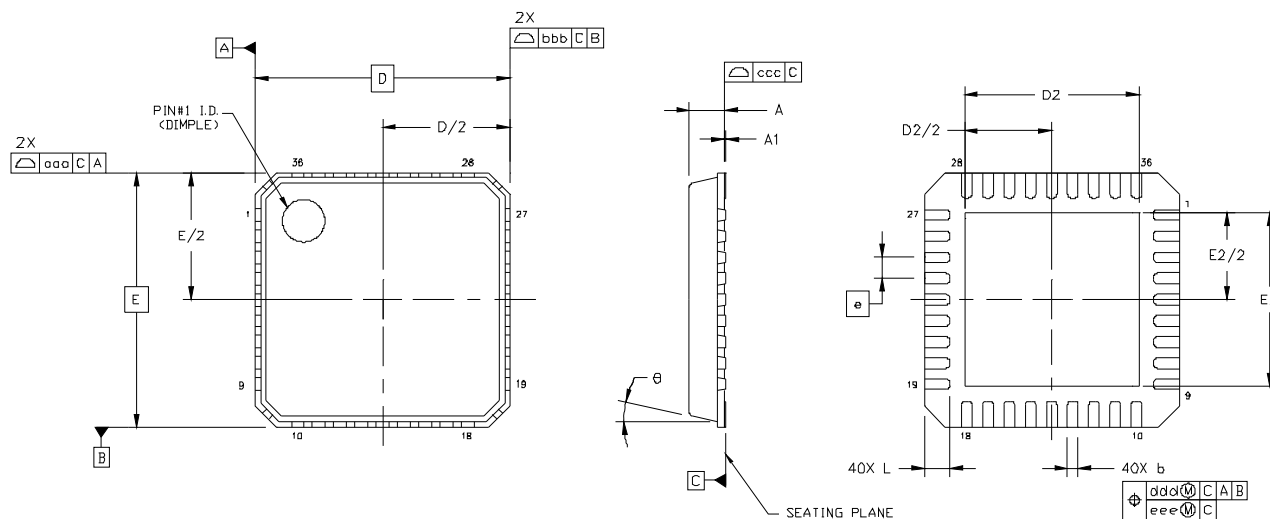

Figure 9. 36-Pin Quad Flat No-lead (QFN)

Table 15. Package Dimensions

Symbol	Millimeters			Symbol	Millimeters		
	Min	Nom	Max		Min	Nom	Max
A	0.80	0.85	0.90	L	0.50	0.60	0.70
A1	0.00	0.02	0.05	θ	—	—	12°
b	0.18	0.25	0.30	aaa	—	—	0.10
D	6.00 BSC			bbb	—	—	0.10
D2	3.95	4.10	4.25	ccc	—	—	0.08
e	0.50 BSC			ddd	—	—	0.10
E	6.00 BSC			eee	—	—	0.05
E2	3.95	4.10	4.25				

Notes:

- All dimensions shown are in millimeters (mm) unless otherwise noted.
- Dimensioning and Tolerancing per ANSI Y14.5M-1994.
- This drawing conforms to JEDEC outline MO-220, variation VJJD.
- Recommended card reflow profile is per the JEDEC/IPC J-STD-020 specification for Small Body Components.

Table 16. PCB Land Pattern Dimensions

Dimension	MIN	MAX
e	0.50 BSC.	
E	5.42 REF.	
D	5.42 REF.	
E2	4.00	4.20
D2	4.00	4.20
GE	4.53	—
GD	4.53	—
X	—	0.28
Y	0.89 REF.	
ZE	—	6.31
ZD	—	6.31

Notes:

General

- All dimensions shown are in millimeters (mm) unless otherwise noted.
- Dimensioning and Tolerancing is per the ANSI Y14.5M-1994 specification.
- This Land Pattern Design is based on IPC-SM-782 guidelines.
- All dimensions shown are at Maximum Material Condition (MMC). Least Material Condition (LMC) is calculated based on a Fabrication Allowance of 0.05 mm.

Solder Mask Design

- All metal pads are to be non-solder mask defined (NSMD). Clearance between the solder mask and the metal pad is to be 60 μm minimum, all the way around the pad.

Stencil Design

- A stainless steel, laser-cut and electro-polished stencil with trapezoidal walls should be used to assure good solder paste release.
- The stencil thickness should be 0.125 mm (5 mils).
- The ratio of stencil aperture to land pad size should be 1:1 for the perimeter pads.
- A 4 x 4 array of 0.80 mm square openings on 1.05 mm pitch should be used for the center ground pad.

Card Assembly

- A No-Clean, Type-3 solder paste is recommended.
- The recommended card reflow profile is per the JEDEC/IPC J-STD-020 specification for Small Body Components.

Si5324

10. Top Marking

10.1. Si5324 Top Marking (QFN)

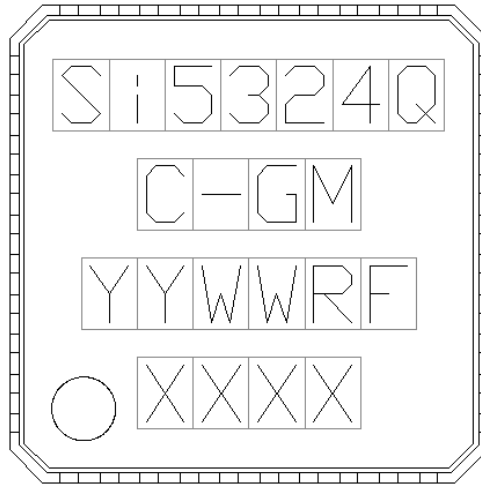

10.2. Top Marking Explanation

Mark Method:	Laser	
Font Size:	0.80 mm Right-Justified	
Line 1 Marking:	Si5324Q	Customer Part Number Q = Speed Code: A, B, C, D See Ordering Guide for options.
Line 2 Marking:	C-GM	C = Product Revision G = Temperature Range -40 to 85 °C (RoHS6) M = QFN Package
Line 3 Marking:	YYWWRF	YY = Year WW = Work Week R = Die Revision F = Internal code Assigned by the Assembly House. Corresponds to the year and work week of the mold date.
Line 4 Marking:	Pin 1 Identifier	Circle = 0.75 mm Diameter Lower-Left Justified
	XXXX	Internal Code

DOCUMENT CHANGE LIST

Revision 0.1 to Revision 0.2

- Updated Rise/Fall Time values.
- Updated minimum loop BW value.

Revision 0.2 to Revision 0.25

- Updated features and applications.
- Changed maximum loop bandwidth to 525 Hz (global).
- Updated PLL performance specifications in Table 1.
- Added Typical Video Phase Noise Plot and data.
- Removed references to Si5325.
- Added note to register CKOUT_ALWAYS_ON on how to control output to output skew.
- Added Product Selection Guide to Section “7. Ordering Guide”.
- Corrected typographical errors in Table 1.
- Updated typical phase noise performance page.
- Updated functional description.
- Added additional phase noise plots to Section “3.3. Typical Phase Noise Performance”.
- Updated Register Map.
- Revised Device Top Mark.

Revision 0.25 to Revision 0.3

- Changed Any-Rate to Any-Frequency
- Changed Table 2, “Absolute Maximum Ratings,” on page 6.
- Added Table 11, “CKOUT_ALWAYS_ON and SQ_ICAL Truth Table,” on page 25
- Added “no bypass with CMOS outputs”

Revision 0.3 to Revision 1.0

- Expanded spec Tables 1 and 2 to include all specifications in the Reference Manual.
- Reordered sections to conform to data sheet quality convention.
- Added t_{SETTLE} specification.
- Corrected minor register map typos.
- Minor changes to Table 2.
- Added maximum lock and settle times to Table 3.
- Added titles to Tables 8, 9, and 10.
- Updated/added selection guide Tables 13 and 14.
- Removed SLEEP from register map.
- Added warning about MEMS reference oscillators to “3.1. External Reference” on page 20.

Revision 1.0 to Revision 1.1

- Added reference to AN803 on pages 11,19,20,34,62.
- Added additional LOL and Settling Time Specs on page 11.
- Added new part numbers on page 64.



SKYWORKS®

ClockBuilder Pro

Customize Skyworks clock generators, jitter attenuators and network synchronizers with a single tool. With CBPro you can control evaluation boards, access documentation, request a custom part number, export for in-system programming and more!

www.skyworksinc.com/CBPro



Portfolio

www.skyworksinc.com/ia/timing



SW/HW

www.skyworksinc.com/CBPro

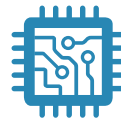

Quality

www.skyworksinc.com/quality



Support & Resources

www.skyworksinc.com/support

Copyright © 2021 Skyworks Solutions, Inc. All Rights Reserved.

Information in this document is provided in connection with Skyworks Solutions, Inc. ("Skyworks") products or services. These materials, including the information contained herein, are provided by Skyworks as a service to its customers and may be used for informational purposes only by the customer. Skyworks assumes no responsibility for errors or omissions in these materials or the information contained herein. Skyworks may change its documentation, products, services, specifications or product descriptions at any time, without notice. Skyworks makes no commitment to update the materials or information and shall have no responsibility whatsoever for conflicts, incompatibilities, or other difficulties arising from any future changes.

No license, whether express, implied, by estoppel or otherwise, is granted to any intellectual property rights by this document. Skyworks assumes no liability for any materials, products or information provided hereunder, including the sale, distribution, reproduction or use of Skyworks products, information or materials, except as may be provided in Skyworks' Terms and Conditions of Sale.

THE MATERIALS, PRODUCTS AND INFORMATION ARE PROVIDED "AS IS" WITHOUT WARRANTY OF ANY KIND, WHETHER EXPRESS, IMPLIED, STATUTORY, OR OTHERWISE, INCLUDING FITNESS FOR A PARTICULAR PURPOSE OR USE, MERCHANTABILITY, PERFORMANCE, QUALITY OR NON-INFRINGEMENT OF ANY INTELLECTUAL PROPERTY RIGHT; ALL SUCH WARRANTIES ARE HEREBY EXPRESSLY DISCLAIMED. SKYWORKS DOES NOT WARRANT THE ACCURACY OR COMPLETENESS OF THE INFORMATION, TEXT, GRAPHICS OR OTHER ITEMS CONTAINED WITHIN THESE MATERIALS. SKYWORKS SHALL NOT BE LIABLE FOR ANY DAMAGES, INCLUDING BUT NOT LIMITED TO ANY SPECIAL, INDIRECT, INCIDENTAL, STATUTORY, OR CONSEQUENTIAL DAMAGES, INCLUDING WITHOUT LIMITATION, LOST REVENUES OR LOST PROFITS THAT MAY RESULT FROM THE USE OF THE MATERIALS OR INFORMATION, WHETHER OR NOT THE RECIPIENT OF MATERIALS HAS BEEN ADVISED OF THE POSSIBILITY OF SUCH DAMAGE.



Skyworks products are not intended for use in medical, lifesaving or life-sustaining applications, or other equipment in which the failure of the Skyworks products could lead to personal injury, death, physical or environmental damage. Skyworks customers using or selling Skyworks products for use in such applications do so at their own risk and agree to fully indemnify Skyworks for any damages resulting from such improper use or sale.

Customers are responsible for their products and applications using Skyworks products, which may deviate from published specifications as a result of design defects, errors, or operation of products outside of published parameters or design specifications. Customers should include design and operating safeguards to minimize these and other risks. Skyworks assumes no liability for applications assistance, customer product design, or damage to any equipment resulting from the use of Skyworks products outside of Skyworks' published specifications or parameters.

Skyworks, the Skyworks symbol, Sky5®, SkyOne®, SkyBlue™, Skyworks Green™, Clockbuilder®, DSPLL®, ISOModem®, ProSLIC®, and SiPHY® are trademarks or registered trademarks of Skyworks Solutions, Inc. or its subsidiaries in the United States and other countries. Third-party brands and names are for identification purposes only and are the property of their respective owners. Additional information, including relevant terms and conditions, posted at www.skyworksinc.com, are incorporated by reference.

Looking for pricing, stock, or lifecycle information?

Click below to explore more details on WIN SOURCE:

-  [View SI5324B-C-GMR on WIN SOURCE](#)
-  [Skyworks Solutions Inc. Information](#)

Optimize Your Supply Chain with WIN SOURCE Solutions

-  Global Sourcing Solution
-  Obsolete Management
-  Cost Control Management
-  Shortage Management
-  Alternative Solution
-  Excess Inventory Management