



**THE DATASHEET OF
SI51219-A14BFT**



THREE OUTPUTS FACTORY PROGRAMMABLE CLOCK GENERATOR

Features

- Generates up to 3 CMOS clock outputs from 3 to 200 MHz
- Accepts crystal or reference clock input
 - 3 to 166 MHz reference clock input
 - 8 to 48 MHz crystal input
- Programmable FSEL, SSEL, SSON, PD, and OE input functions
- Low power dissipation
- Separate voltage supply pins
 - $V_{DD} = 2.5$ to 3.3 V
 - $V_{DDO} = 1.8$ to 3.3 V ($V_{DDO} \leq V_{DD}$)
- 0.25% to 1.0% Spread Spectrum (Center Spread)
- Low cycle-cycle jitter
- Programmable output rise and fall times
- 8-pin TSSOP package

Applications

- Crystal/XO replacement
- EMI reduction
- Portable devices
- Digital still camera
- IP phone
- Home gateway

Description

The factory programmable Si51219 is a low power, small footprint and frequency flexible programmable clock generator targeting low power, low cost and high volume consumer and embedded applications. The device operates from a single crystal or an external clock source and generates 1 to 3 outputs up to 200 MHz. They are factory programmed to provide customized output frequencies, control inputs and ac parameter tuning like output drive strength that are optimized for customer board condition and application requirements. A separate VDDO supply pin supports clock output at a different voltage level.

Functional Block Diagram

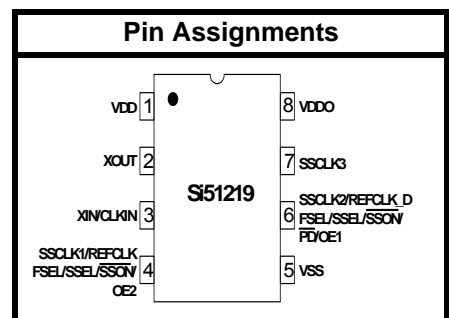
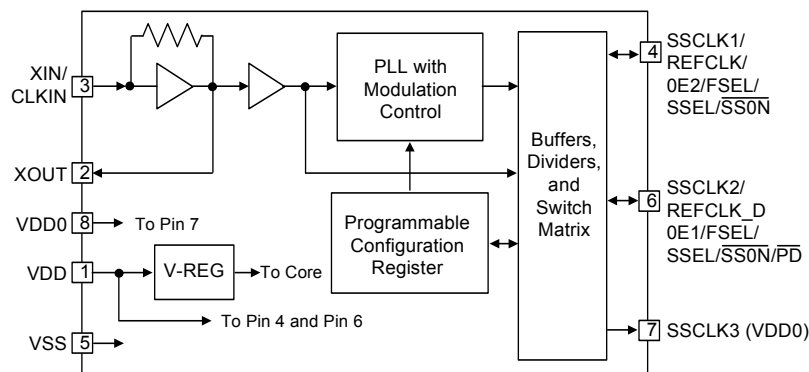

Patents pending

TABLE OF CONTENTS

<u>Section</u>	<u>Page</u>
1. Electrical Specifications	4
2. Design Considerations	6
2.1. Typical Application Schematic	6
3. Functional Descriptions	7
3.1. Input Frequency Range	7
3.2. Output Frequency Range and Outputs	7
3.3. Programmable Modulation Frequency	7
3.4. Programmable Spread Percent (%)	7
3.5. SSON or Frequency Select (FSEL)	7
3.6. Power Down (PD) or Output Enable (OE)	7
4. Pin Descriptions: 8-Pin TSSOP	8
5. Ordering Information	9
6. Package Outline: 8-pin TSSOP	10
Contact Information	12

1. Electrical Specifications

Table 1. DC Electrical Specifications

($V_{DD} = 2.5\text{ V} \pm 5\%$, or $V_{DD} = 3.3\text{ V} \pm 10\%$, $T_A = 0$ to $70\text{ }^\circ\text{C}$)

Parameter	Symbol	Test Condition	Min	Typ	Max	Unit
Operating Voltage	V_{DD}	$V_{DD}=3.3\text{ V} \pm 10\%$	2.97	3.3	3.63	V
		$V_{DD}=2.5\text{ V} \pm 5\%$	2.375	2.5	2.625	V
	V_{DDO}	$V_{DDO} \leq V_{DD}$	1.71	—	3.6	V
Output High Voltage	V_{OH}	$I_{OH} = -4\text{ mA}$, $V_{DDX} = V_{DD}$ or V_{DDO}	$V_{DDX} - 0.5$	—	—	V
Output Low Voltage	V_{OL}	$I_{OL} = 4\text{ mA}$,	—	—	0.3	V
Input High Voltage	V_{IH}	CMOS level	$0.7 V_{DD}$	—	—	V
Input Low Voltage	V_{IL}	CMOS level	—	—	$0.3 V_{DD}$	V
Operating Supply Current	I_{DD}	$F_{IN}=12\text{ MHz}$, CLKOUT1 =12 MHz, CLKOUT2/3 =24 MHz, $C_L=0$, $V_{DD}=3.3\text{ V}$	—	6	—	mA
Nominal Output Impedance	Z_O		—	30	—	Ω
Internal Pull-up/Pull-down Resistor	R_{PUP}/R_{PD}	Pin 6	—	150k	—	Ω
Input Pin Capacitance	C_{IN}	Input Pin Capacitance	—	3	5	pF
Load Capacitance	C_L	Clock outputs < 166 MHz	—	—	15	pF
		Clock outputs > 166 MHz	—	—	10	pF

Table 2. AC Electrical Specifications $(V_{DD} = 2.5\text{ V} \pm 5\%$, or $V_{DD} = 3.3\text{ V} \pm 10\%$, $T_A = 0$ to $70\text{ }^\circ\text{C}$)

Parameter	Symbol	Condition	Min	Typ	Max	Unit
Input Frequency Range	F_{IN1}	Crystal input	8	—	48	MHz
Input Frequency Range	F_{IN2}	Reference clock Input	3	—	166	MHz
Output Frequency Range	F_{OUT}	SSCLK1/2/3	3	—	200	MHz
Frequency Accuracy	F_{ACC}	Configuration dependent	—	0	—	ppm
Output Duty Cycle	DC_{OUT}	Measured at $V_{DD}/2$	45	50	55	%
Input Duty Cycle	DC_{IN}	CLKIN, CLKOUT through PLL	30	50	70	%
Output Rise Time	t_r	$C_L=15\text{ pF}$, 20 to 80%	—	1	3.0	ns
Output Fall Time	t_f	$C_L=15\text{ pF}$, 20 to 80%	—	1	3.0	ns
Period Jitter	PJ_1	SSCLK1/2/3, three clocks running, $V_{DD}=3.3\text{ V}$, $CL=15\text{ pF}$	—	150*	—	ps
Cycle-to-Cycle Jitter	CCJ_1	SSCLK1/2/3, three clocks running, $V_{DD}=3.3\text{ V}$, $CL=15\text{ pF}$	—	100*	—	ps
Power-up Time	t_{PU}	Time from $0.9 V_{DD}$ to valid frequencies at all clock outputs	—	1.2	5.0	ms
Output Enable Time	t_{OE}	Time from OE raising edge to active at output SSCLK1/2 (asynchronous)	—	15	—	ns
Output Disable Time	t_{OD}	Time from OE falling edge to active at output SSCLK1/2 (asynchronous)	—	15	—	ns

*Note: Jitter performance depends on configuration and programming parameters.

Table 3. Absolute Maximum Conditions

Parameter	Symbol	Condition	Min	Typ	Max	Unit
Main Supply Voltage	V_{DD}		-0.5	—	4.2	V
Input Voltage	V_{IN}	Relative to V_{SS}	-0.5	—	$V_{DD}+0.5$	V
Temperature, Storage	T_S	Non-functional	-65	—	150	$^\circ\text{C}$
Temperature, Operating Ambient	T_A	Functional, C-Grade	0	—	70	$^\circ\text{C}$
Temperature, Junction	T_J	Functional, power is applied	—	—	125	$^\circ\text{C}$
Temperature, Soldering	T_{Sol}	Non-functional	—	—	260	$^\circ\text{C}$
Dissipation, Junction to Case	\emptyset_{JC}	Independent of air flow	—	—	36	$^\circ\text{C/W}$
Dissipation, Junction to Ambient	\emptyset_{JA}	Still air	—	181	—	$^\circ\text{C/W}$
	\emptyset_{JA}	1m/s air flow	—	100	—	$^\circ\text{C/W}$
	\emptyset_{JA}	3m/s air flow	—	80	—	$^\circ\text{C/W}$
ESD Protection (Human Body Model)	ESD_{HBM}	JEDEC (JESD 22-A114)	-4000	—	4000	V
ESD Protection (Charge Device Model)	ESD_{CDM}	JEDEC (JESD 22-C101)	-1500	—	1500	V
ESD Protection (Machine Model)	ESD_{MM}	JEDEC (JESD 22-A115)	-200	—	200	V
Moisture Sensitivity Level	MSL	JEDEC (J-STD-020)	1			

Note: While using multiple power supplies, the Voltage on any input or I/O pin cannot exceed the power pin during power-up. Power supply sequencing is not required.

2. Design Considerations

2.1. Typical Application Schematic

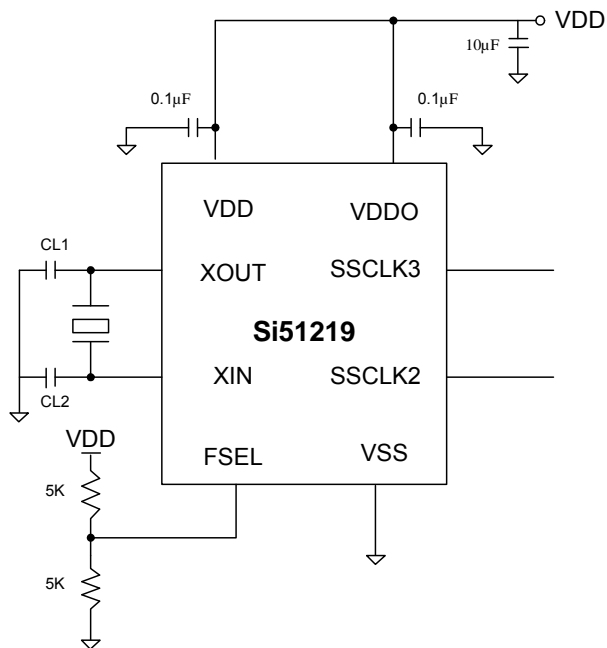

Comments and Recommendations

Decoupling Capacitor: A decoupling capacitor of 0.1 µF must be used between VDD and VSS on the pins 1 and 8. Place the capacitor on the component side of the PCB as close to the VDD pin as possible. The PCB trace to the VDD pin and to the GND via should be kept as short as possible. Do not use vias between the decoupling capacitor and the VDD pin. In addition, a 10 µF capacitor should be placed between VDD and VSS.

Series Termination Resistor: A series termination resistor is recommended if the distance between the outputs (SSCLK or REFCLK pins) and the load is over 1 ½ inch. The nominal impedance of the SSCLK output is about 30 Ω. Use 20 Ω resistor in series with the output to terminate 50 Ω trace impedance and place 20 Ω resistor as close to the SSCLK output as possible.

Crystal and Crystal Load: Only use a parallel resonant fundamental AT cut crystal. **Do not use higher overtone crystals.** To meet the crystal initial accuracy specification (in ppm) make sure that external crystal load capacitor is matched to crystal load specification. To determine the value of CL1 and CL2, use the following formula;

$$C1 = C2 = 2CL - (Cpin + Cp)$$

Where: CL is load capacitance stated by crystal manufacturer

Cpin is the Si51219 pin capacitance (4 pF)

Cp is the parasitic capacitance of the PCB traces.

Example: If a crystal with CL=12 pF specification is used and Cp=1 pF (parasitic PCB capacitance on PCB), 19 or 20 pF external capacitors from pins XIN (pin 2) and XOUT (Pin 3) to VSS are required. Users must verify Cp value.

3. Functional Descriptions

3.1. Input Frequency Range

The input frequency range is from 8.0 to 48.0 MHz for crystals and ceramic resonators. If an external clock is used, the input frequency range is from 8.0 to 166.0 MHz.

3.2. Output Frequency Range and Outputs

Up to three outputs can be programmed as SSCLK or REFCLK. SSCLK output can be synthesized to any value from 3 to 200 MHz with spread based on valid input frequency. The spread at SSCLK pins can be stopped by the $\overline{\text{SSON}}$ input control pin. If $\overline{\text{SSON}}$ pin is high (V_{DD}), the frequency at SSCLK pin is synthesized to the nominal value of the input frequency and there is no spread.

REFCLK is the buffered output of the oscillator and is the same frequency as the input frequency without spread. However, REFCLK_D output is divided by output dividers from 2 to 32. By using only low cost, fundamental mode crystals, the Si51219 can synthesize output frequency up to 200 MHz, eliminating the need for higher order crystals (Xtals) and crystal oscillators (XOs). This reduces the cost while improving the system clock accuracy, performance, and reliability.

3.3. Programmable Modulation Frequency

The spread spectrum clock (SSC) modulation default value is 31.5 kHz. The higher values of up to 62 kHz can also be programmed. Less than 30 kHz modulation frequency is not recommended to stay out of the range audio frequency bandwidth since this frequency could be detected as a noise by the audio receivers within the vicinity.

3.4. Programmable Spread Percent (%)

The spread percent (%) value is programmable from $\pm 0.25\%$ to $\pm 1\%$ (center spread) for all SSCLK frequencies. It is possible to program smaller or larger non-standard values of spread percentage. Contact Silicon Labs if these non-standard spread percent values are required in the application.

3.5. $\overline{\text{SSON}}$ or Frequency Select (FSEL)

The Si51219 pin 4 and 6 can be programmed as either $\overline{\text{SSON}}$ to enable or disable the programmed spread percent value or as frequency select (FSEL). If $\overline{\text{SSON}}$ is used, when this pin is pulled high (V_{DD}), the spread is stopped and the frequency is the nominal value without spread. If low (GND), the frequency is the nominal value with the spread.

If FSEL function is used, the output pins can be programmed for different set of frequencies as selected by FSEL. SSCLK value can be any frequency from 3 to 200 MHz, but the spread % is the same percent value. REFCLK is the same frequency as the input reference clock and the REFCLK_D input clock is divided by 2 to 32 without spread. The set of frequencies in Table 4 is given as an example, using a 48 MHz crystal.

Table 4. Example Frequencies

FSEL (Pin 6)	SSCLK1 (Pin 4)
0	66 MHz, $\pm 1\%$
1	33 MHz, $\pm 1\%$

3.6. Power Down ($\overline{\text{PD}}$) or Output Enable (OE)

The Si51219 pin 6 can be programmed as $\overline{\text{PD}}$ input. Pin 4 and pin 6 can be programmed as OE input. $\overline{\text{PD}}$ turns off both PLL and output buffers whereas OE only disables the output buffers to Hi-Z.

4. Pin Descriptions: 8-Pin TSSOP

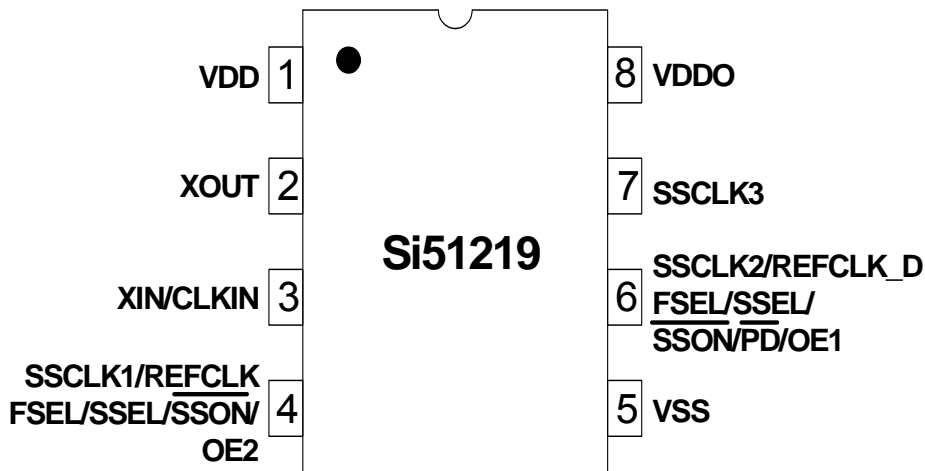
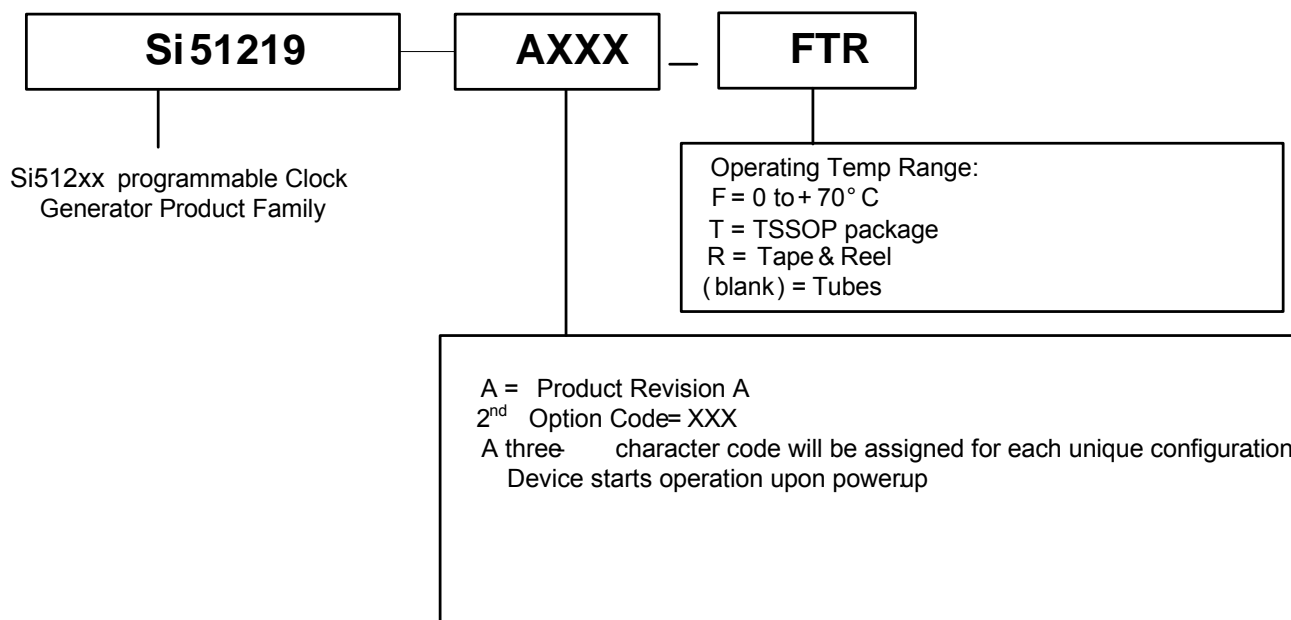

Table 5. Si51219 Pin Descriptions

Pin #	Name	Type	Description
1	VDD	PWR	2.5 to 3.3 V power supply.
2	XOUT	O	Crystal output. Leave this pin unconnected (floating) if an external clock input is used.
3	XIN/CLKIN	I	External crystal and clock input.
4	SSCLK1/REFCLK/ FSEL/SSEL/SSON/ OE2	I/O	Programmable SSCLK1 or REFCLK output or MultiFunction control input. The frequency at this pin is synthesized by internal PLL if programmed as SSCLK1 with or without spread. If programmed as REFCLK, output clock is buffered output of crystal or reference clock input. If programmed as MultiFunction control input, it can be OE, FSEL, SSEL and SSON.
5	VSS	GND	Ground.
6	SSCLK2/REFCLK_D/ OE1/FSEL/SSEL/ SSON/PD	I/O	Programmable SSCLK2 or REFCLK_D output or MultiFunction control input. The frequency at this pin is synthesized by internal PLL if programmed as SSCLK2 with or without spread. If programmed as REFCLK_D, output clock is buffered output of crystal or reference clock input divided by 2 to 32. If programmed as MultiFunction control input, it can be OE, PD, FSEL, SSEL and SSON.
7	SSCLK3	O	Programmable SSCLK3 output. The frequency at this pin is synthesized by internal PLL with or without spread. It is power by VDDO pin (pin 8).
8	VDDO	PWR	1.8 to 3.3 V output power supply to SSCLK3 (pin 7) $V_{DDO} \leq V_{DD}$.

5. Ordering Information

Part Number	Package Type	Temperature
Si51219-AxxxFT	8-pin TSSOP	Commercial, 0 to 70 °C
Si51219-AxxxFTR	8-pin TSSOP—Tape and Reel	Commercial, 0 to 70 °C



6. Package Outline: 8-pin TSSOP

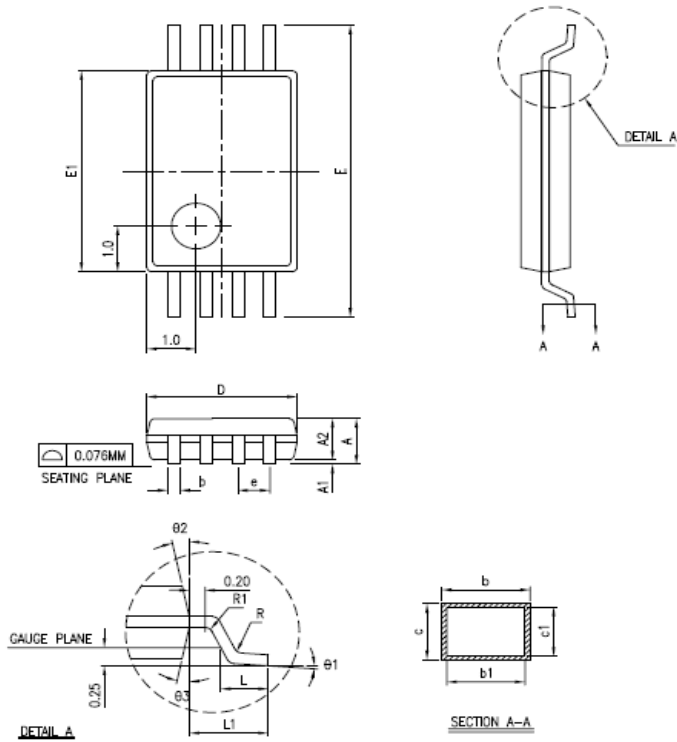

SYMBOL	DIMENSION IN MM			DIMENSION IN INCH		
	MIN.	NOM.	MAX.	MIN.	NOM.	MAX.
A			1.20			.047
A1	0.05		0.15	.002		.006
A2	0.80	0.90	1.05	.031	.035	.041
L	0.50	0.60	0.75	.020	.024	.030
D	2.90	3.00	3.10	.114	.118	.122
E	6.30	6.40	6.50	.248	.252	.256
E1	4.30	4.40	4.50	.169	.173	.177
R	0.09			.004		
R1	0.09			.004		
b	0.19		0.30	.007		.012
b1	0.19	0.22	0.25	.007	.009	.010
c	0.09		0.20	.004		.008
c1	0.09		0.16	.004		.006
L1	1.0 REF.			.039 REF.		
e	0.65 BSC.			.026 BSC.		
Ø1	0		8	0		8
Ø2	12 REF.			12 REF.		
Ø3	12 REF.			12 REF.		
N	8					
REF	JEDEC MO-153 VARIATION AA					

NOTES:



ClockBuilder Pro

One-click access to Timing tools, documentation, software, source code libraries & more. Available for Windows and iOS (CBGo only).

www.silabs.com/CBPro



Timing Portfolio
www.silabs.com/timing



SW/HW
www.silabs.com/CBPro



Quality
www.silabs.com/quality



Support and Community
community.silabs.com

Disclaimer

Silicon Laboratories intends to provide customers with the latest, accurate, and in-depth documentation of all peripherals and modules available for system and software implementers using or intending to use the Silicon Laboratories products. Characterization data, available modules and peripherals, memory sizes and memory addresses refer to each specific device, and "Typical" parameters provided can and do vary in different applications. Application examples described herein are for illustrative purposes only. Silicon Laboratories reserves the right to make changes without further notice and limitation to product information, specifications, and descriptions herein, and does not give warranties as to the accuracy or completeness of the included information. Silicon Laboratories shall have no liability for the consequences of use of the information supplied herein. This document does not imply or express copyright licenses granted hereunder to design or fabricate any integrated circuits. The products must not be used within any Life Support System without the specific written consent of Silicon Laboratories. A "Life Support System" is any product or system intended to support or sustain life and/or health, which, if it fails, can be reasonably expected to result in significant personal injury or death. Silicon Laboratories products are generally not intended for military applications. Silicon Laboratories products shall under no circumstances be used in weapons of mass destruction including (but not limited to) nuclear, biological or chemical weapons, or missiles capable of delivering such weapons.

Trademark Information

Silicon Laboratories Inc., Silicon Laboratories, Silicon Labs, SiLabs and the Silicon Labs logo, CMEMS®, EFM, EFM32, EFR, Energy Micro, Energy Micro logo and combinations thereof, "the world's most energy friendly microcontrollers", Ember®, EZLink®, EZMac®, EZRadio®, EZRadioPRO®, DSPLL®, ISOmodem®, Precision32®, ProSLIC®, SiPHY®, USBXpress® and others are trademarks or registered trademarks of Silicon Laboratories Inc. ARM, CORTEX, Cortex-M3 and THUMB are trademarks or registered trademarks of ARM Holdings. Keil is a registered trademark of ARM Limited. All other products or brand names mentioned herein are trademarks of their respective holders.



SILICON LABS

Silicon Laboratories Inc.
400 West Cesar Chavez
Austin, TX 78701
USA

<http://www.silabs.com>

Looking for pricing, stock, or lifecycle information?

Click below to explore more details on WIN SOURCE:

-  [View SI51219-A14BFT on WIN SOURCE](#)
-  [Skyworks Solutions Inc. Information](#)

Optimize Your Supply Chain with WIN SOURCE Solutions

-  Global Sourcing Solution
-  Obsolete Management
-  Cost Control Management
-  Shortage Management
-  Alternative Solution
-  Excess Inventory Management