



THE DATASHEET OF SL2305NZSI





SKYWORKS®

Timing Solutions

Product Selector Guide

1117 Rev2





Timing Solutions

Skyworks offers a broad portfolio of timing products that enable hardware designers to simplify clock generation, clock distribution, jitter attenuation and network synchronization. These products combine best-in-class jitter performance and frequency flexibility, enabling customers to easily architect optimized clock tree solutions. Custom samples are available in 1-2 weeks, easing design and reducing time-to-market.







Timing
A comprehensive portfolio of oscillators, clock buffers, clock generators, PCI Express (PCIe) clocks, jitter attenuators and SyncE/IEEE 1588 network synchronizers with PTP software.

Products

 <p>Oscillators</p> <ul style="list-style-type: none"> • Any frequency up to 3.0 GHz • Ultra-low jitter: 80 fs RMS • Short lead times: 1-2 weeks (samples) 	 <p>Clock Buffers</p> <ul style="list-style-type: none"> • Integrated format/level translation • Ultra-low additive jitter: 50 fs RMS • PCI Express Gen 1/2/3/4/5/6 compliant
 <p>Jitter Attenuators and Clock Generators</p> <ul style="list-style-type: none"> • Any-frequency, any-output with JESD204B/C support • Ultra-low jitter: <55 fs RMS • Clock tree on a chip replaces clocks and XOs • PCI Express Gen 1/2/3/4/5/6 compliant • Integrated reference options 	 <p>NetSync™ Network Synchronizers and AccuTime™ 1588 PTP Software</p> <ul style="list-style-type: none"> • Any frequency, any output with JESD204B/C support • Ultra-low jitter: <55 fs RMS • ITU-T G.8273.2 (T-TSC, T-BC), ITU-T G.8273.4 (T-BC-P, T-BC-A, T-TSC-P, T-TSC-A), G.8262 (EEC Options 1 and 2), G.8262.1 (eEEEC), and G.8273.1 (T-GM) compliance

Applications

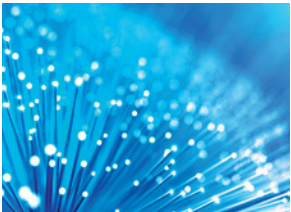
 <ul style="list-style-type: none"> ▪ Enterprise routers ▪ Cable/DSL ▪ PON 	 <ul style="list-style-type: none"> ▪ Radio units (RU) ▪ Baseband units (BBU) ▪ O-RAN Back-haul/Mid-haul/ Front-haul (O-RU, O-DU, O-CU) ▪ Small Cells/DAS/Picocells
 <ul style="list-style-type: none"> ▪ Switches/servers ▪ Storage/security ▪ Search acceleration ▪ Machine learning ▪ Edge/Cloud computing 	 <ul style="list-style-type: none"> ▪ Broadcast video ▪ Industrial ▪ Medical imaging ▪ Test and measurement ▪ Emulation & prototyping ▪ Aerospace and defense
 <ul style="list-style-type: none"> ▪ Data center interconnect ▪ 100G/400G/800G/1.2T Optical Transport ▪ WDM ▪ Carrier Ethernet 	 <ul style="list-style-type: none"> ▪ ADAS/Automated Driving ▪ Networking Gateways ▪ Domain Controllers ▪ Centralized Compute ▪ Lidar and vision systems ▪ IVI/Digital Cockpit

Crystal Oscillators (XO)

Skyworks offers a comprehensive portfolio of high performance, low jitter XOs and VCXOs. Skyworks' new Si54x and Si56x Ultra Series™ family of high performance XOs delivers ultra-low jitter and frequency flexibility. All devices are highly customizable, with samples of any XO available with 1-2 week lead times.

Portfolio Key Features

- Industry's lowest jitter any frequency XOs
- Jitter as low as 80 fs RMS typ
- Any frequency up to 3.0 GHz
- Single, dual, quad and I2C prog. options
- LVPECL, LVDS, HCSL, CML, LVCMOS
- Superior stability vs. SAW oscillators
- Power supply noise rejection eliminates discrete LDO
- Single device supports 1.8 – 3.3 V operation
- -40° to +85° C operation
- 5x7 mm, 3.2x5mm, 2.5x3.2mm
- Samples in 1-2 weeks

Example Application: 100G/200G/400G Optical Module

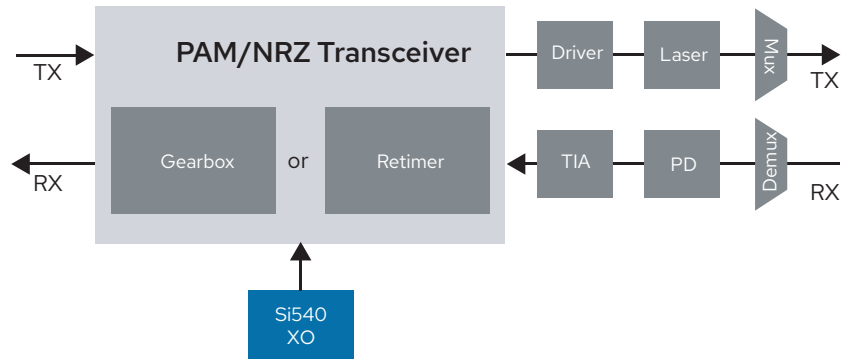

Featured Products

PERFORMANCE OPTION	PART NUMBER	NUMBER OF FREQUENCIES	FREQUENCY RANGE	TYP JITTER (fsRMS)	TOTAL STABILITY (±PPM)	LVPECL	LVDS	HCSL	CML	LVCMOS	DUAL LVCMOS	VOLTAGE (V)	PACKAGE SIZE (MM)
ULTRA LOW JITTER	Si545 Si546 Si547 Si548 Si549	SINGLE DUAL QUAD ANY (I2C) ANY (I2C)	200 kHz to 1.5 GHz	80	20, 25, 50	✓	✓	✓	✓	✓	✓	1.8 - 3.3	5 x 7 3.2 x 5 2.5 x 3.2
	Si540 Si541 Si542 Si544	SINGLE DUAL QUAD ANY (I2C)	200 kHz to 1.5 GHz	125	20, 25, 50	✓	✓	✓	✓	✓	✓	1.8 - 3.3	5 x 7 3.2 x 5 2.5 x 3.2
	Si560 Si561 Si562 Si564	SINGLE DUAL QUAD ANY (I2C)	200 kHz to 3.0 GHz	90	50	✓	✓	✓	✓	✓	✓	1.8 - 3.3	5 x 7 3.2 x 5 2.5 x 3.2
LOW JITTER	Si530/1 Si532/3 Si534 Si570	SINGLE DUAL QUAD ANY (I2C)	10 MHz to 1.4 GHz	300	20, 31.5, 61.5	✓	✓		✓	✓		1.8, 2.5, 3.3	5 x 7
GENERAL PURPOSE	Si590/1 Si598	SINGLE ANY (I2C)	10 MHz to 810 MHz	500	20, 30, 50, 100	✓	✓			✓		1.8, 2.5, 3.3	5 x 7 3.2 x 5
	Si510/1 Si512/3 Si514	SINGLE DUAL ANY (I2C)	100 kHz to 250 MHz	800	30, 50, 100	✓	✓	✓		✓	✓	1.8, 2.5, 3.3	5 x 7 3.2 x 5 2.5 x 3.2



Voltage-Controlled Crystal Oscillators (VCXO)

Skyworks offers a comprehensive portfolio of high performance, low jitter XO's and VCXO's. Skyworks' new Si56x Ultra Series™ family of high performance VCXO's deliver exceptional jitter performance and 5x tighter control voltage linearity than competing solutions, maximizing design margin while simplifying development. All devices are highly customizable, with samples of any VCXO available with 1-2 week lead times.

Portfolio Key Features

- Jitter: 100 fs RMS typ (12 kHz – 20 MHz)
- Any frequency up to 3.0 GHz
- Single, dual, quad and I2C prog. options
- LVPECL, LVDS, HCSL, CML, LVCMOS
- Superior linearity vs. traditional VCSO/VCXO's
- Power supply noise rejection eliminates discrete LDO
- 1.8, 2.5 or 3.3 V
- 5x7 mm, 3.2x5 mm, 2.5 x 3.2 mm
- -40° to +85° C operation
- Samples in 1-2 weeks

Example Application: Video Format Converter

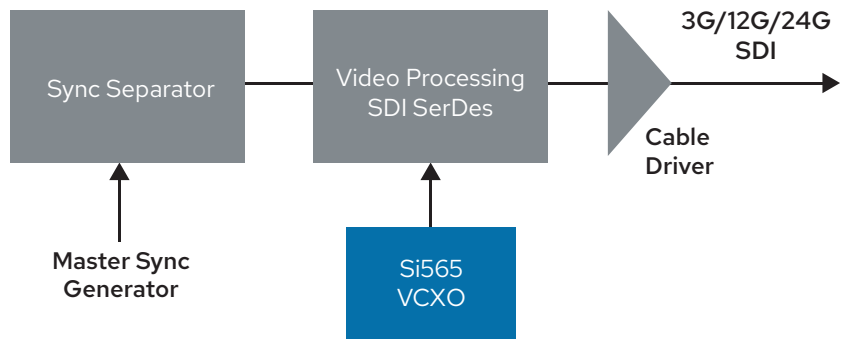

Featured Voltage-Controlled Crystal Oscillators (VCXO)

PERFORMANCE OPTION	PART NUMBER	NUMBER OF FREQUENCIES	FREQUENCY RANGE	TYP JITTER (fsRMS)	MIN APR (±PPM)	LVPECL	LVDS	HCSL	CML	LVCMOS	DUAL LVCMOS	VOLTAGE (V)	PACKAGE SIZE (MM)
ULTRA LOW JITTER	Si565 Si566 Si567 Si569	SINGLE DUAL QUAD ANY (I2C)	200 kHz to 3.0 GHz	100	20 - 190	✓	✓	✓	✓	✓	✓	1.8 - 3.3	5 x 7 3.2 x 5 2.5 x 3.2
LOW JITTER	Si550 Si552 Si554 Si571	SINGLE DUAL QUAD ANY (I2C)	10 MHz to 1.4 GHz	500	12 - 375	✓	✓		✓	✓		1.8, 2.5, 3.3	5 x 7
GENERAL PURPOSE	Si595 Si596 Si597 Si599	SINGLE DUAL QUAD ANY (I2C)	10 MHz to 810 MHz	700	10 - 370	✓	✓		✓	✓		1.8, 2.5, 3.3	5 x 7 3.2 x 5
	Si515 Si516	SINGLE DUAL	100 kHz to 250 MHz	1000	30, 50, 100	✓	✓	✓		✓	✓	1.8, 2.5, 3.3	5 x 7 3.2 x 5 2.5 x 3.2



Clock Generators

Skyworks offers the industry's lowest jitter, most frequency flexible, most highly integrated clock generators. Leveraging Skyworks' proven MultiSynth technology, a single clock generator can replace an entire clock tree of multiple oscillators, buffers, clock generators, and muxes, simplifying design and accelerating time to market. Skyworks' comprehensive clock generator portfolio offers optimized solutions for communications, data center, industrial and consumer applications.

Portfolio Key Features

- Ultra-low jitter as low as 69 fs RMS
- Generate any combination of frequencies
- Lowest jitter fractional clock synthesis
- Programmable format per output
- LVPECL, LVDS, HCSSL, CML, LVCMOS
- Programmable VDDO per output
- Power supply noise rejection eliminates discrete LDO
- PCIe Gen Gen 1/2/3/4/5/6 compliant
- Custom samples in 2 weeks
- ClockBuilder® Pro support

Example Application: Data Center Ethernet Switch

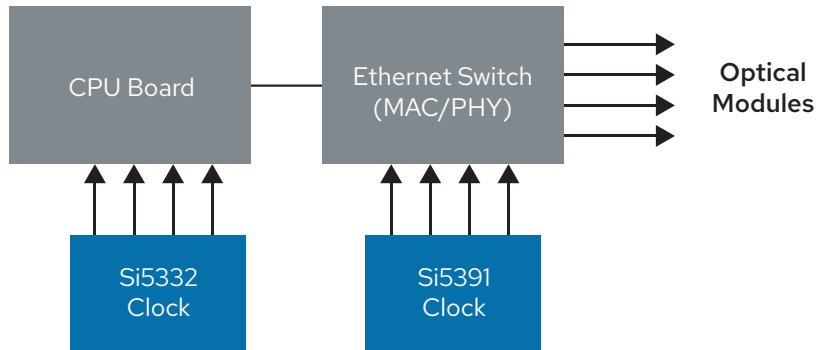

Featured Clock Generators

PERFORMANCE OPTION	PART NUMBER	CLOCK INPUTS	CLOCK OUTPUTS	MAX OUTPUT FREQUENCY	TYP JITTER (fsRMS)	LVPECL	LVDS	HCSSL	CML	LVCMOS	VOLTAGE (V)	PACKAGE
ULTRA LOW JITTER	Si5391/P	4	12	1028 MHz	69	✓	✓	✓	✓	✓	1.8, 3.3	QFN64
	Si5341	4	10	1028 MHz	100	✓	✓	✓	✓	✓	1.8, 3.3	QFN64
	Si5340	4	4	1028 MHz	100	✓	✓	✓	✓	✓	1.8, 3.3	QFN64
LOW JITTER	Si5332	3	6, 8, 12	333 MHz	230	✓	✓	✓	✓	✓	1.8, 2.5, 3.3	QFN48 QFN40 QFN32
GENERAL PURPOSE	Si5338/35/34	2	4	710 MHz	700	✓	✓	✓		✓	1.8, 2.5, 3.3	QFN24
PCI-E CLOCK GENERATORS	Si52202/04/08/12	1	2, 4, 8, 12	133 MHz	240			✓			1.5, 1.8	QFN48 QFN32 QFN24 QFN20
	Si52142/3/4/6/7	1	2, 4, 5, 6, 9	100 MHz	600			✓			3.3	QFN24 QFN24 QFN24 QFN32 QFN48
	Si52111/2	1	1, 2	100 MHz	600			✓		✓	3.3	TDFN10
CMOS CLOCK GENERATORS	Si5350/1	1	3, 4, 8	200 MHz	-					✓	1.8, 2.5, 3.3	MSOP10 QFN16 QFN20
	Si5210/4	1	1, 2, 3	170 MHz	-					✓	1.8, 2.5, 3.3	TDFN6 TDFN8

Clk Gens
ClockBuilder Pro
Clk Gen Development Tools
Reference Designs

Clock Buffers

Skyworks offers a comprehensive portfolio of clock buffers. In addition to universal buffers that support any in/out signal format translation, we offer a wide range of differential and single-ended buffers that provide ultra-low additive jitter and low skew clock distribution. Skyworks also offers a broad range of low-power PCIe buffers that integrate all termination components while providing compliance with PCIe Gen 1/2/3/4/5/6 standards.

Portfolio Key Features

- Ultra-low additive jitter as low as 50 fs RMS
- Clock distribution up to 1.25 GHz
- LVPECL, LVDS, HCSL, CML, LVCMOS
- Pin-selectable signal format
- Individual clock output OE control
- Synchronous, glitchless OE control
- Best-in-class power supply noise rejection
- PCIe: push-pull HCSL drivers
- PCIe: integrated termination resistors
- PCIe: Gen 1/2/3/4/5/6 compliant
- PCIe: Intel-qualified solutions

Example Application: Switch/Router

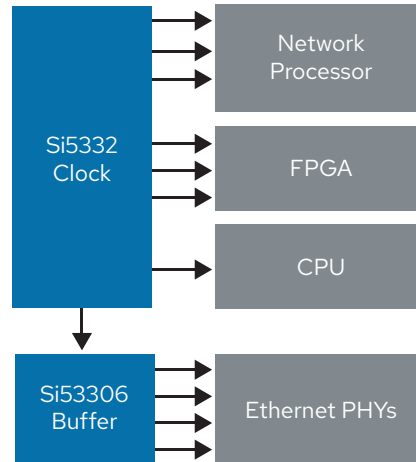

Featured Clock Buffers

PRODUCT FAMILY	PART NUMBER	CLOCK INPUTS	CLOCK OUTPUTS	MAX OUTPUT FREQUENCY	TYP JITTER (fsRMS)	LVPECL	LVDS	HCSL	CML	LVCMOS	VOLTAGE (V)	PACKAGE
ANY FORMAT	Si5331x	2	5, 6, 10	1250 MHz	50	✓	✓	✓	✓	✓	1.8, 2.5, 3.3	32QFN
	Si5330x	1, 2	2, 4, 6, 10	725 MHz	50	✓	✓	✓	✓	✓	1.8, 2.5, 3.3	16QFN 32QFN 44QFN
LVPECL	Si5332x	1, 2	2, 4, 5, 6, 10	1250 MHz	50	✓					2.5, 3.3	QFN16 QFN24 QFN32
LVDS	Si5334x	2	4, 6, 8, 10	1250 MHz	50		✓				1.8, 2.5, 3.3	QFN16 QFN24 QFN32
LVCMO	Si5336x	1, 2	8, 12	200 MHz	100					✓	1.8, 2.5, 3.3	16QFN 24QFN 16TSSOP
PCI EXPRESS	Si53204/8/12	1	4, 8, 12	200 MHz	50			✓			1.5, 1.8	QFN64 QFN48 QFN32
	Si5315x	1	2, 4, 6, 9	210 MHz	100			✓			3.3	24QFN 32QFN 48QFN
	Si53102-A3	1	2	175 MHz	200			✓			2.5, 3.3	8TDFN
PCI EXPRESS ZERO DELAY BUFFERS	Si5311x	1	6, 8, 12	133 MHz	80			✓			3.3	40QFN 48QFN 64QFN

Buffers

PCIe Clock Jitter Tool

Buffer Development Tools

Reference Designs

Jitter Attenuating Clocks

Skyworks offers the industry's lowest jitter, most frequency flexible and integrated jitter attenuating clock generators for Wireless, Wireline, and Data Center equipment. Leveraging Skyworks' proven DSPLL® and MultiSynth technology, a single jitter attenuating clock can synchronize to a wide range of different clocks, filter jitter, and provide any combination of output frequencies, including JESDB2024B/C support. Skyworks offers an extensive range of jitter attenuating clocks to solve the most complex timing challenges in 4G/5G Radio, 100G+ packet optical transport and Ethernet designs.

Portfolio Key Features

- Generate any combination of output frequencies
- Ultra low jitter as low as < 55 fs RMS
- Enhanced hitless switching with phase transients as low as 30 ps
- Programmable loop bandwidth down to 0.1 Hz
- Programmable format per output (LVPECL, LVDS, HCSL, CML, LVCMOS)
- CPRI/eCPRI JESD204B/C outputs
- Power supply noise rejection eliminates discrete LDO
- Custom samples in 2 weeks
- ClockBuilder Pro support

Example Application:

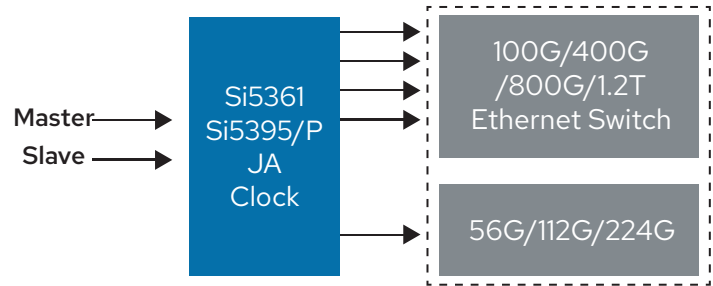

Ethernet

Optical

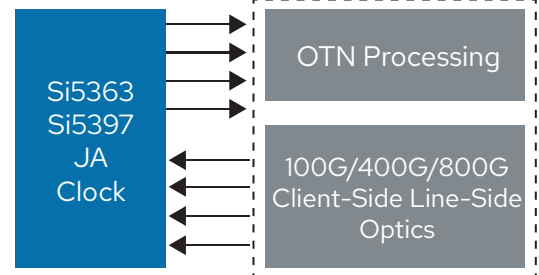

Featured Jitter Attenuating Clocks

APPLICATION	MODEL	# OF DSPLLs	# OF MULTISYNTHS	JESDB204B/C	CLOCK INPUTS	CLOCK OUTPUTS	TYP JITTER RMS	MAX OUTPUT FREQUENCY	LVPECL	LVDS	HCSL	CML	LVCMOS	PACKAGE
OPTICAL NETWORKING AND BROADBAND	Si5363/2/1	3/2/1	0/1/2	N/A	6	18	55 fs RMS	1.3 GHz	✓	✓	✓	✓	✓	72-QFN
	Si5395/4/2	1	5/4/2		4	10/4/2	69 fs RMS	1.028 GHz	✓	✓	✓	✓	✓	64-QFN/44-QFN
	Si5345/4/2	1	5/4/2		4	10/4/2	95 fs RMS	1.028 GHz	✓	✓	✓	✓	✓	64-QFN/44-QFN
	Si5397/6	4/2			4	8/4	95 fs RMS	720 MHz	✓	✓	✓	✓	✓	64-QFN/44-QFN 64-LGA/44-LGA
	Si5347/6	4/2			4	8/4	95 fs RMS	720 MHz	✓	✓	✓	✓	✓	64-QFN/44-QFN
COHERENT OPTICS	Si5361H	1	2	N/A	6	18	50 fs RMS	2.75 GHz	✓	✓	✓	✓	✓	72-QFN
	Si5344H/42H	1	2/1		2	4/2	50 fs RMS	2.75 GHz	✓	✓	✓	✓	✓	44-QFN
5G RADIO UNITS (RU), SMALL CELLS, PICO CELLS, DAS, JESDB204B/C SUPPORT	Si5508	1		✓	6	18	55 fs RMS	3 GHz	✓	✓	✓	✓	✓	72-QFN
	Si5510	1	2	✓	6	18	55 fs RMS	3 GHz	✓	✓	✓	✓	✓	72-QFN
	Si5386	1	4	✓	4	12	86 fs RMS	2.949 GHz	✓	✓	✓	✓	✓	64-QFN/64-LGA

Jitter Attenuators

ClockBuilder Pro

JA Development Tools

Reference Designs

NetSync™ Network Synchronizers with AccuTime™ IEEE 1588 Software

Skyworks offers the industry’s most highly integrated clocking solutions for Wireless and Wireline equipment, including 5G radio access networks replacing three devices with a single NetSync™ network synchronizer IC simplifying the overall BOM. Leveraging Skyworks’ proven fifth-generation DSPLL and MultiSynth technology, a single NetSync™ clock supports Synchronous Ethernet (SyncE)-compliant wander filtering, 1PPS/PP2S inputs, and software adjustment of output frequency and phase for IEEE 1588 applications, with support for CPRI/eCPRI JESD204B/C. These devices offer ultra-low jitter, ultra-low phase noise output clocks, eliminating the need for a follow-on jitter attenuator device. With up to 3 DSPLLs and flexible MultiSynth placement this unique architecture can reduce complexity and size while achieving low power consumption.

NetSync™ clocks can be combined with Skyworks’ AccuTime™ software to provide a fully standards compliant IEEE 1588 Precision Time Protocol (PTP) solution operating in full timing support (FTS), partial timing support (PTS), assisted partial timing support (APTS), and PTP-unaware networks. Alternatively, NetSync™ clocks can be used with just the servo portion of AccuTime alongside an existing PTP stack implementation to achieve superior performance without increased software effort, or just the NetSync™ device can be used with third-party PTP software.

Portfolio Key Features

- Ultra-low <55 fs RMS jitter
- Programmable loop bandwidth down to 1mHz
- Best-in-class phase noise and noise floor
- Support for 1PPS/PP2S input and output
- Synchronous, free-run, holdover modes
- Automatic/manual hitless switching
- Pin or SW-controlled IEEE 1588 DCO (1 ppt/step)
- Suitable for ITU-T G.8273.1 (T-GM), G.8273.2 (T-TSC, T-BC), and G.8273.4 (T-BC-P, T-BC-A, T-TSC-P, T-TSC-A),
- Meets G.8262 (EEC Options 1 and 2) and G.8262.1 (eEEEC)
- ClockBuilder Pro and AccuTime support

Example Application: Telecom Boundary Clock

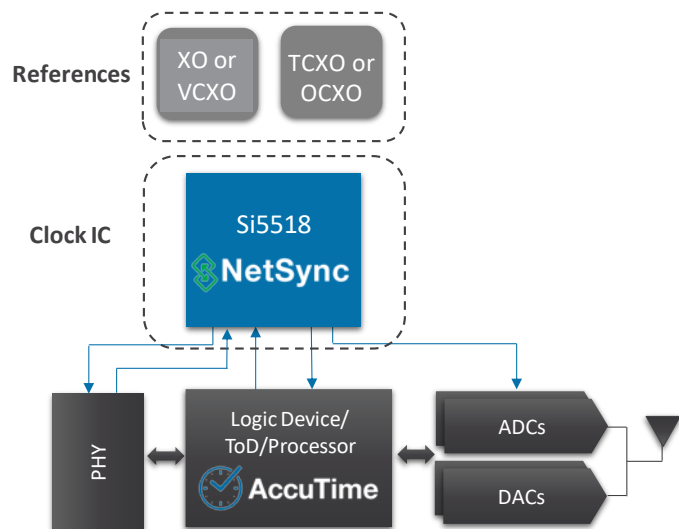

Featured Network Synchronizers

APPLICATION	MODEL	# OF DSPLLs	CLOCK INPUTS	CLOCK OUTPUTS	TYP JITTER RMS	MIN INPUT FREQUENCY	MAX OUTPUT FREQUENCY	MIN PLL INPUT BW	ACCUTIME SUPPORT	LVPECL	LVDS	HCSL	CML	LVCOS	PACKAGE
5G RU, 5G O-RU, SMALL CELLS, PICO CELLS, DAS, MMIMO RADIOS, FIXED WIRELESS RADIOS	Si5512	4	6	12	< 55 fs RMS	1PPS	1.228 GHz	1 mHz	Yes	✓	✓	✓	✓	✓	72-QFN
	Si5518	4	6	18	< 55 fs RMS	1PPS	3.2 GHz	1 mHz	Yes	✓	✓	✓	✓	✓	72-QFN
5G BASEBAND UNITS, 5G O-RAN CENTRAL UNIT (O-CU) DISTRIBUTED UNIT (O-DU) FRONT-HAUL GATEWAY SWITCHES (FHGWS), IEEE 1588 GRANDMASTERS, BOUNDARY CLOCKS AND SLAVES, SMARTNICS, CORE, METRO AND EDGE SWITCHES AND ROUTERS	Si5401	3	6	10	< 60 fs RMS	1PPS	1.28GHz	1 mHz	Yes	✓	✓	✓	✓	✓	72-QFN
	Si5402	4	6	14	< 60 fs RMS	1PPS	1.28GHz	1 mHz	Yes	✓	✓	✓	✓	✓	72-QFN
	Si5403	4	6	18	< 60 fs RMS	1PPS	1.28GHz	1 mHz	Yes	✓	✓	✓	✓	✓	72-QFN
	Si5348	3	5	7	95 fs RMS	8 kHz	718.5 MHz	1 mHz	No	✓	✓	✓	✓	✓	64-QFN

NetSync™
NetSync™ Software Tools
NetSync™ Dev Tools
Reference Designs

AEC-Q100 Automotive Grade Timing Products

Skyworks offers a comprehensive portfolio of automotive grade 2 timing solutions, providing system designers with solutions that simplify clock tree design, add redundancy, reduce system points of failure, increase system reliability and optimize the performance of high-speed serial data transfer in automotive infotainment, advanced driver assistance systems (ADAS), Lidar/radar sensors and automated driving ECU platforms.

Portfolio Key Features

- 6/8/12-output clock generators
- Multi-format clock buffers
- PCIe Gen1/2/3/4/5 clocks and buffers
- SmartClock™ health monitoring
- -40°C to +105°C, AEC-Q100 qualified
- ClockBuilder Pro support

Example Application:

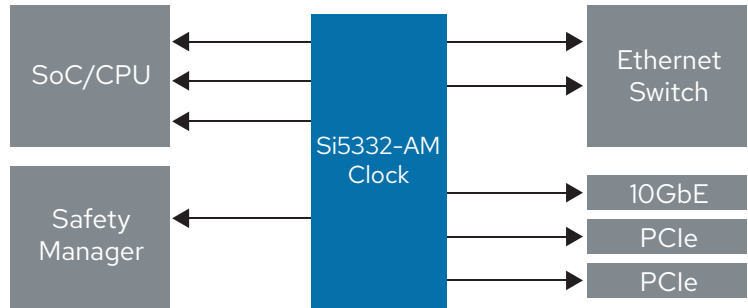

Featured Products

PRODUCT TYPE	PART NUMBER	CLOCK INPUTS	CLOCK OUTPUTS	MAX OUTPUT FREQUENCY	TYP JITTER (fsRMS)	PCIe	LVPECL	LVDS	HCSL	LVC MOS	VOLTAGE (V)	PACKAGE
CLOCK GENERATORS	Si5332-AM	2	6	333 MHz	190	Gen 1/2/3/4/5	✓	✓	✓	✓	1.8, 3.3	QFN32
		3	8	333 MHz	190	Gen 1/2/3/4/5	✓	✓	✓	✓	1.8, 3.3	QFN40
		3	12	333 MHz	190	Gen 1/2/3/4/5	✓	✓	✓	✓	1.8, 3.3	QFN48
CLOCK BUFFERS	Si53352	1	2	333 MHz	120 (additive)	Gen 1/2/3/4/5	✓	✓	✓	✓	1.8, 3.3	QFN32
	Si53354	1	4	333 MHz	120 (additive)	Gen 1/2/3/4/5	✓	✓	✓	✓	1.8, 3.3	QFN40
	Si53358	2	8	333 MHz	120 (additive)	Gen 1/2/3/4/5	✓	✓	✓	✓	1.8, 3.3	QFN40
	Si53350	2	10	333 MHz	120 (additive)	Gen 1/2/3/4/5	✓	✓	✓	✓	1.8, 3.3	QFN48
PCIe CLOCK GENERATORS	Si52254	1	4	100 MHz	25	Gen 1/2/3/4/6			✓		1.8, 3.3	QFN32
	Si52258	1	8	100 MHz	25	Gen 1/2/3/4/7			✓		1.8, 3.3	QFN40
PCIe CLOCK BUFFERS	Si53254	2	4	100 MHz	25 (additive)	Gen 1/2/3/4/8			✓		1.8, 3.3	QFN32
	Si53258	2	8	100 MHz	25 (additive)	Gen 1/2/3/4/9			✓		1.8, 3.3	QFN40

[Product Website](#)

[ClockBuilder Pro](#)

[PCIe Clock Jitter Tool](#)

[Development Tools](#)



Copyright ©2023 Skyworks Solutions, Inc. All Rights Reserved.

Information in this document is provided in connection with Skyworks Solutions, Inc. ("Skyworks") products or services. These materials, including the information contained herein, are provided by Skyworks as a service to its customers and may be used for informational purposes only by the customer. Skyworks assumes no responsibility for errors or omissions in these materials or the information contained herein. Skyworks may change its documentation, products, services, specifications or product descriptions at any time, without notice. Skyworks makes no commitment to update the materials or information and shall have no responsibility whatsoever for conflicts, incompatibilities, or other difficulties arising from any future changes.

No license, whether express, implied, by estoppel or otherwise, is granted to any intellectual property rights by this document. Skyworks assumes no liability for any materials, products or information provided hereunder, including the sale, distribution, reproduction or use of Skyworks products, information or materials, except as may be provided in Skyworks' Terms and Conditions of Sale.

THE MATERIALS, PRODUCTS AND INFORMATION ARE PROVIDED "AS IS" WITHOUT WARRANTY OF ANY KIND, WHETHER EXPRESS, IMPLIED, STATUTORY, OR OTHERWISE, INCLUDING FITNESS FOR A PARTICULAR PURPOSE OR USE, MERCHANTABILITY, PERFORMANCE, QUALITY OR NON-INFRINGEMENT OF ANY INTELLECTUAL PROPERTY RIGHT; ALL SUCH WARRANTIES ARE HEREBY EXPRESSLY DISCLAIMED. SKYWARKS DOES NOT WARRANT THE ACCURACY OR COMPLETENESS OF THE INFORMATION, TEXT, GRAPHICS OR OTHER ITEMS CONTAINED WITHIN THESE MATERIALS. SKYWARKS SHALL NOT BE LIABLE FOR ANY DAMAGES, INCLUDING BUT NOT LIMITED TO ANY SPECIAL,

INDIRECT, INCIDENTAL, STATUTORY, OR CONSEQUENTIAL DAMAGES, INCLUDING WITHOUT LIMITATION, LOST REVENUES OR LOST PROFITS THAT MAY RESULT FROM THE USE OF THE MATERIALS OR INFORMATION, WHETHER OR NOT THE RECIPIENT OF MATERIALS HAS BEEN ADVISED OF THE POSSIBILITY OF SUCH DAMAGE.



Skyworks products are not intended for use in medical, lifesaving or life-sustaining applications, or other equipment in which the failure of the Skyworks products could lead to personal injury, death, physical or environmental damage. Skyworks customers using or selling Skyworks products for use in such applications do so at their own risk and agree to fully indemnify Skyworks for any damages resulting from such improper use or sale.

Customers are responsible for their products and applications using Skyworks products, which may deviate from published specifications as a result of design defects, errors, or operation of products outside of published parameters or design specifications. Customers should include design and operating safeguards to minimize these and other risks. Skyworks assumes no liability for applications assistance, customer product design, or damage to any equipment resulting from the use of Skyworks products outside of Skyworks' published specifications or parameters.

Skyworks, the Skyworks symbol, Sky5®, SkyOne®, SkyBlue™, Skyworks Green™, Clockbuilder®, DSPLL®, ISOModem®, ProSLIC®, and SiPHY® are trademarks or registered trademarks of Skyworks Solutions, Inc. or its subsidiaries in the United States and other countries. Third-party brands and names are for identification purposes only and are the property of their respective owners. Additional information, including relevant terms and conditions, posted at skyworksin.com, are incorporated by reference.

Looking for pricing, stock, or lifecycle information?

Click below to explore more details on WIN SOURCE:

-  [View SL2305NZSI on WIN SOURCE](#)
-  [Skyworks Solutions Inc. Information](#)

Optimize Your Supply Chain with WIN SOURCE Solutions

-  Global Sourcing Solution
-  Obsolete Management
-  Cost Control Management
-  Shortage Management
-  Alternative Solution
-  Excess Inventory Management