



**THE DATASHEET OF  
CY9BF524KPMC-G-MNE2**





**Please note that Cypress is an Infineon Technologies Company.**

The document following this cover page is marked as “Cypress” document as this is the company that originally developed the product. Please note that Infineon will continue to offer the product to new and existing customers as part of the Infineon product portfolio.

**Continuity of document content**

The fact that Infineon offers the following product as part of the Infineon product portfolio does not lead to any changes to this document. Future revisions will occur when appropriate, and any changes will be set out on the document history page.

**Continuity of ordering part numbers**

Infineon continues to support existing part numbers. Please continue to use the ordering part numbers listed in the datasheet for ordering.



## CY9B520M Series

# 32-bit Arm® Cortex®-M3 FM3 Microcontroller

The CY9B520M Series are highly integrated 32-bit microcontrollers dedicated for embedded controllers with low-power consumption mode and competitive cost.

These series are based on the Arm® Cortex®-M3 Processor with on-chip Flash memory and SRAM, and have peripheral functions such as various timers, ADCs, DACs and Communication Interfaces (USB, CAN, UART, CSIO, I<sup>2</sup>C, LIN).

The products which are described in this data sheet are placed into TYPE9 product categories in "FM3 Family Peripheral Manual".

## Features

### 32-bit Arm® Cortex®-M3 Core

- Processor version: r2p1
- Up to 72 MHz Frequency Operation
- Integrated Nested Vectored Interrupt Controller (NVIC): 1 NMI (non-maskable interrupt) and 48 peripheral interrupts and 16 priority levels
- 24-bit System timer (Sys Tick): System timer for OS task management

### On-chip Memories

#### [Flash memory]

- Dual operation Flash memory
  - Dual Operation Flash memory has the upper bank and the lower bank.  
So, this series could implement erase, write and read operations for each bank simultaneously.
  - Main area: Up to 256 Kbytes (Up to 240 Kbytes upper bank + 16 Kbytes lower bank)
  - Work area: 32 Kbytes (lower bank)
- Read cycle: 0 wait-cycle
- Security function for code protection

#### [SRAM]

This Series on-chip SRAM is composed of two independent SRAM (SRAM0, SRAM1). SRAM0 is connected to I-code bus and D-code bus of Cortex-M3 core. SRAM1 is connected to System bus.

- SRAM0: Up to 16 Kbytes
- SRAM1: Up to 16 Kbytes

### USB Interface

The USB interface is composed of Device and Host. PLL for USB is built-in, USB clock can be generated by multiplication of Main clock.

#### [USB device]

- USB2.0 Full-Speed supported
- Max 6 EndPoint supported
  - EndPoint 0 is control transfer
  - EndPoint 1, 2 can select Bulk-transfer, Interrupt-transfer or Isochronous-transfer
  - EndPoint 3 to 5 can select Bulk-transfer or Interrupt-transfer
  - EndPoint 1 to 5 are comprised of Double Buffers.
  - The size of each endpoint is according to the follows.
    - Endpoint 0, 2 to 5: 64 bytes
    - Endpoint 1: 256 bytes

#### [USB host]

- USB2.0 Full/Low-speed supported
- Bulk-transfer, interrupt-transfer and Isochronous-transfer support
- USB Device connected/dis-connected automatic detection
- Automatic processing of the IN/OUT token handshake packet
- Max 256-byte packet-length supported
- Wake-up function supported

### CAN Interface

- Compatible with CAN Specification 2.0A/B
- Maximum transfer rate: 1 Mbps
- Built-in 32 message buffer

### Multi-function Serial Interface (Max eight channels)

- 4 channels with 16 steps×9-bit FIFO (ch.0/1/3/4), 4 channels without FIFO (ch.2/5/6/7)
- Operation mode is selectable from the followings for each channel.
  - UART
  - CSIO
  - LIN
  - I<sup>2</sup>C

**[UART]**

- Full duplex double buffer
- Selection with or without parity supported
- Built-in dedicated baud rate generator
- External clock available as a serial clock
- Hardware Flow control: Automatically control the transmission/reception by CTS/RTS (only ch.4)
- Various error detection functions available (parity errors, framing errors, and overrun errors)

**[CSIO]**

- Full duplex double buffer
- Built-in dedicated baud rate generator
- Overrun error detection function available

**[LIN]**

- LIN protocol Rev.2.1 supported
- Full duplex double buffer
- Master/Slave mode supported
- LIN break field generation (can be changed to 13 to 16-bit length)
- LIN break delimiter generation (can be changed to 1 to 4-bit length)
- Various error detection functions available (parity errors, framing errors, and overrun errors)

**[I<sup>2</sup>C]**

Standard mode (Max 100 kbps) / Fast mode (Max 400 kbps) supported

**DMA Controller (Eight channels)**

The DMA Controller has an independent bus from the CPU, so CPU and DMA Controller can process simultaneously.

- 8 independently configured and operated channels
- Transfer can be started by software or request from the built-in peripherals
- Transfer address area: 32-bit (4 Gbytes)
- Transfer mode: Block transfer/Burst transfer/Demand transfer
- Transfer data type: byte/half-word/word
- Transfer block count: 1 to 16
- Number of transfers: 1 to 65536

**A/D Converter (Max 26 channels)****[12-bit A/D Converter]**

- Successive Approximation type
- Built-in 2 units
- Conversion time: 0.8  $\mu$ s @ 5 V
- Priority conversion available (priority at 2 levels)
- Scanning conversion mode
- Built-in FIFO for conversion data storage (for SCAN conversion: 16 steps, for Priority conversion: 4 steps)

**D/A Converter (Max two channels)**

- R-2R type
- 10-bit resolution

**Base Timer (Max eight channels)**

Operation mode is selectable from the followings for each channel.

- 16-bit PWM timer
- 16-bit PPG timer
- 16-/32-bit reload timer
- 16-/32-bit PWC timer

**General-Purpose I/O Port**

This series can use its pins as general-purpose I/O ports when they are not used for peripherals. Moreover, the port relocate function is built in. It can set which I/O port the peripheral function can be allocated to.

- Capable of pull-up control per pin
- Capable of reading pin level directly
- Built-in the port relocate function
- Up to 65 high-speed general-purpose I/O Ports @ 80pin Package
- Some ports are 5V tolerant.
- See "List of Pin Functions" and "I/O Circuit Type" to confirm the corresponding pins.

**Dual Timer (32-/16-bit Down Counter)**

The Dual Timer consists of two programmable 32-/16-bit down counters.

Operation mode is selectable from the followings for each channel.

- Free-running
- Periodic (=Reload)
- One-shot

### Quadrature Position/Revolution Counter (QPRC) (Max two channels)

The Quadrature Position/Revolution Counter (QPRC) is used to measure the position of the position encoder. Moreover, it is possible to use as the up/down counter.

- The detection edge of the three external event input pins AIN, BIN and ZIN is configurable.
- 16-bit position counter
- 16-bit revolution counter
- Two 16-bit compare registers

### Multi-function Timer

The Multi-function timer is composed of the following blocks.

- 16-bit free-run timer × 3 ch./unit
- Input capture × 4 ch./unit
- Output compare × 6 ch./unit
- A/D activation compare × 2 ch./unit
- Waveform generator × 3 ch./unit
- 16-bit PPG timer × 3 ch./unit

The following function can be used to achieve the motor control.

- PWM signal output function
- DC chopper waveform output function
- Dead time function
- Input capture function
- A/D convertor activate function
- DTIF (Motor emergency stop) interrupt function

### Real-time clock (RTC)

The Real-time clock can count Year/Month/Day/Hour/Minute/Second/A day of the week from 00 to 99.

- The interrupt function with specifying date and time (Year/Month/Day/Hour/Minute) is available. This function is also available by specifying only Year, Month, Day, Hour or Minute.
- Timer interrupt function after set time or each set time.
- Capable of rewriting the time with continuing the time count.
- Leap year automatic count is available.

### Watch Counter

The Watch counter is used for wake up from Sleep and Timer mode.

Interval timer: up to 64 s (Max) @ Sub Clock: 32.768 kHz

### External Interrupt Controller Unit

- Up to 23 external interrupt input pins @ 80 pin Package
- Include one non-maskable interrupt (NMI) input pin

### Watchdog Timer (Two channels)

A watchdog timer can generate interrupts or a reset when a time-out value is reached.

This series consists of two different watchdogs, a "Hardware" watchdog and a "Software" watchdog.

The "Hardware" watchdog timer is clocked by the built-in Low-speed CR oscillator. Therefore, the "Hardware" watchdog is active in any low-power consumption modes except RTC, Stop, Deep Standby RTC, Deep Standby Stop modes.

### CRC (Cyclic Redundancy Check) Accelerator

The CRC accelerator calculates the CRC which has a heavy software processing load, and achieves a reduction of the integrity check processing load for reception data and storage. CCITT CRC16 and IEEE-802.3 CRC32 are supported.

- CCITT CRC16 Generator Polynomial: 0x1021
- IEEE-802.3 CRC32 Generator Polynomial: 0x04C11DB7

### Clock and Reset

#### [Clocks]

Selectable from five clock sources (2 external oscillators, 2 built-in CR oscillators, and Main PLL).

- Main Clock: 4 MHz to 48 MHz
- Sub Clock: 32.768 kHz
- Built-in High-speed CR Clock: 4 MHz
- Built-in Low-speed CR Clock: 100 kHz
- Main PLL Clock

#### [Resets]

- Reset requests from INITX pin
- Power-on reset
- Software reset
- Watchdog timers reset
- Low-voltage detection reset
- Clock Super Visor reset

### Clock Super Visor (CSV)

Clocks generated by built-in CR oscillators are used to supervise abnormality of the external clocks.

- If external clock failure (clock stop) is detected, reset is asserted.
- If external frequency anomaly is detected, interrupt or reset is asserted.

**Low-Voltage Detector (LVD)**

This Series includes 2-stage monitoring of voltage on the VCC pins. When the voltage falls below the voltage that has been set, Low-Voltage Detector generates an interrupt or reset.

- LVD1: error reporting via interrupt
- LVD2: auto-reset operation

**Low-Power Consumption Mode**

Six low-power consumption modes supported.

- Sleep
- Timer
- RTC
- Stop
- Deep Standby RTC (selectable between keeping the value of RAM and not)
- Deep Standby Stop (selectable between keeping the value of RAM and not)

**Debug**

Serial Wire JTAG Debug Port (SWJ-DP)

**Unique ID**

Unique value of the device (41 bits) is set.

**Power Supply**

Wide range voltage:

VCC = 2.7 V to 5.5 V

USBVCC = 3.0 V to 3.6 V (when USB is used)

= 2.7 V to 5.5 V (when GPIO is used)

## Contents

<b>1. Product Lineup</b> .....	<b>7</b>
<b>2. Packages</b> .....	<b>8</b>
<b>3. Pin Assignment</b> .....	<b>9</b>
<b>4. List of Pin Functions</b> .....	<b>15</b>
<b>5. I/O Circuit Type</b> .....	<b>33</b>
<b>6. Handling Precautions</b> .....	<b>39</b>
6.1 Precautions for Product Design .....	39
6.2 Precautions for Package Mounting.....	40
6.3 Precautions for Use Environment .....	41
<b>7. Handling Devices</b> .....	<b>42</b>
<b>8. Block Diagram</b> .....	<b>44</b>
<b>9. Memory Size</b> .....	<b>45</b>
<b>10. Memory Map</b> .....	<b>45</b>
<b>11. Pin Status in Each CPU State</b> .....	<b>48</b>
<b>12. Electrical Characteristics</b> .....	<b>54</b>
12.1 Absolute Maximum Ratings.....	54
12.2 Recommended Operating Conditions.....	56
12.3 DC Characteristics.....	57
12.3.1 Current Rating.....	57
12.3.2 Pin Characteristics .....	60
12.4 AC Characteristics.....	61
12.4.1 Main Clock Input Characteristics.....	61
12.4.2 Sub Clock Input Characteristics .....	62
12.4.3 Built-in CR Oscillation Characteristics.....	63
12.4.4 Operating Conditions of Main and USB PLL (In the case of using main clock for input of PLL).....	64
12.4.5 Operating Conditions of Main PLL (In the case of using built-in high-speed CR for input clock of Main PLL).....	64
12.4.6 Reset Input Characteristics .....	65
12.4.7 Power-on Reset Timing.....	65
12.4.8 Base Timer Input Timing .....	66
12.4.9 CSIO/UART Timing.....	67
12.4.10 External Input Timing.....	75
12.4.11 Quadrature Position/Revolution Counter timing.....	76
12.4.12 I <sup>2</sup> C Timing.....	78
12.4.13 JTAG Timing.....	79
12.5 12-bit A/D Converter.....	80
12.5.1 Definition of 12-bit A/D Converter Terms .....	82
12.6 10-bit D/A Converter.....	83
12.7 USB Characteristics .....	84
12.8 Low-Voltage Detection Characteristics.....	88
12.8.1 Low-Voltage Detection Reset.....	88
12.8.2 Interrupt of Low-Voltage Detection.....	89
12.9 Flash Memory Write/Erase Characteristics .....	90
12.9.1 Write / Erase time.....	90
12.9.2 Write cycles and data hold time .....	90
12.10 Return Time from Low-Power Consumption Mode.....	91
12.10.1 Return Factor: Interrupt/WKUP.....	91

12.10.2 Return Factor: Reset .....	93
<b>13. Ordering Information .....</b>	<b>95</b>
<b>14. Package Dimensions .....</b>	<b>96</b>
<b>15. Major Changes .....</b>	<b>104</b>
<b>Document History .....</b>	<b>107</b>
<b>Sales, Solutions, and Legal Information.....</b>	<b>109</b>

## 1. Product Lineup

### Memory Size

Product name		CY9BF521K/L/M	CY9BF522K/L/M	CY9BF524K/L/M
On-chip Flash memory	Main area	64 Kbytes	128 Kbytes	256 Kbytes
	Work area	32 Kbytes	32 Kbytes	32 Kbytes
On-chip SRAM	SRAM0	8 Kbytes	8 Kbytes	16 Kbytes
	SRAM1	8 Kbytes	8 Kbytes	16 Kbytes
	Total	16 Kbytes	16 Kbytes	32 Kbytes

### Function

Product name		CY9BF521K CY9BF522K CY9BF524K	CY9BF521L CY9BF522L CY9BF524L	CY9BF521M CY9BF522M CY9BF524M
Pin count		48	64	80/96
CPU		Cortex-M3		
Freq.		72 MHz		
Power supply voltage range		2.7 V to 5.5 V		
USB2.0 (Device/Host)		1 ch. (Max)		
CAN		1 ch. (Max)		
DMAC		8 ch.		
Multi-function Serial Interface (UART/CSIO/LIN/I <sup>2</sup> C)		4 ch. (Max) ch.0/1/3: FIFO ch.5: No FIFO (In ch.1/5, only UART and LIN are available.)	8 ch. (Max) ch.0/1/3/4 FIFO ch.2/5/6/7: No FIFO (In ch.1, only UART and LIN are available.)	
Base Timer (PWC/Reload timer/PWM/PPG)		8 ch. (Max)		
MF-Timer	A/D activation compare	2 ch.	1 unit	
	Input capture	4 ch.*		
	Free-run timer	3 ch.		
	Output compare	6 ch.		
	Waveform generator	3 ch.		
	PPG	3 ch.		
QPRC		1 ch.	2 ch. (Max)	
Dual Timer		1 unit		
Real-Time Clock		1 unit		
Watch Counter		1 unit		
CRC Accelerator		Yes		
Watchdog timer		1 ch. (SW) + 1 ch. (HW)		
External Interrupts		14 pins (Max) + NMI x 1	19 pins (Max) + NMI x 1	23 pins (Max) + NMI x 1
I/O ports		35 pins (Max)	50 pins (Max)	65 pins (Max)
12-bit A/D converter		14 ch. (2 units)	23 ch. (2 units)	26 ch. (2 units)
10-bit D/A converter		2 ch. (Max)		
CSV (Clock Super Visor)		Yes		
LVD (Low-Voltage Detector)		2 ch.		
Built-in CR	High-speed	4 MHz		
	Low-speed	100 kHz		
Debug Function		SWJ-DP		
Unique ID		Yes		

\*: The external input channel which can be used is shown as follows.

- ch.0 to ch.3: CY9BF521M/F522M/F524M
- ch.0, ch.2, ch.3: CY9BF521K/F522K/F524K, CY9BF521L/F522L/F524L

### Note:

- All signals of the peripheral function in each product cannot be allocated by limiting the pins of package. It is necessary to use the port relocate function of the I/O port according to your function use. See "12. Electrical Characteristics 12.4. AC Characteristics 12.4.3 Built-in CR Oscillation Characteristics" for accuracy of built-in CR.

## 2. Packages

Package	Product name	CY9BF521K CY9BF522K CY9BF524K	CY9BF521L CY9BF522L CY9BF524L	CY9BF521M CY9BF522M CY9BF524M
LQFP:	LQA048 (0.5 mm pitch)	○	-	-
QFN:	VNA048 (0.5 mm pitch)	○	-	-
LQFP:	LQD064 (0.5 mm pitch)	-	○	-
LQFP:	LQG064 (0.65 mm pitch)	-	○	-
QFN:	VNC064 (0.5 mm pitch)	-	○	-
LQFP:	LQH080 (0.5 mm pitch)	-	-	○
LQFP:	LQJ080 (0.65 mm pitch)	-	-	○
BGA:	FDG096 (0.5 mm pitch)	-	-	○

○: Supported

**Note:**

- See "Package Dimensions" for detailed information on each package.

### 3. Pin Assignment

#### LQH080/LQJ080

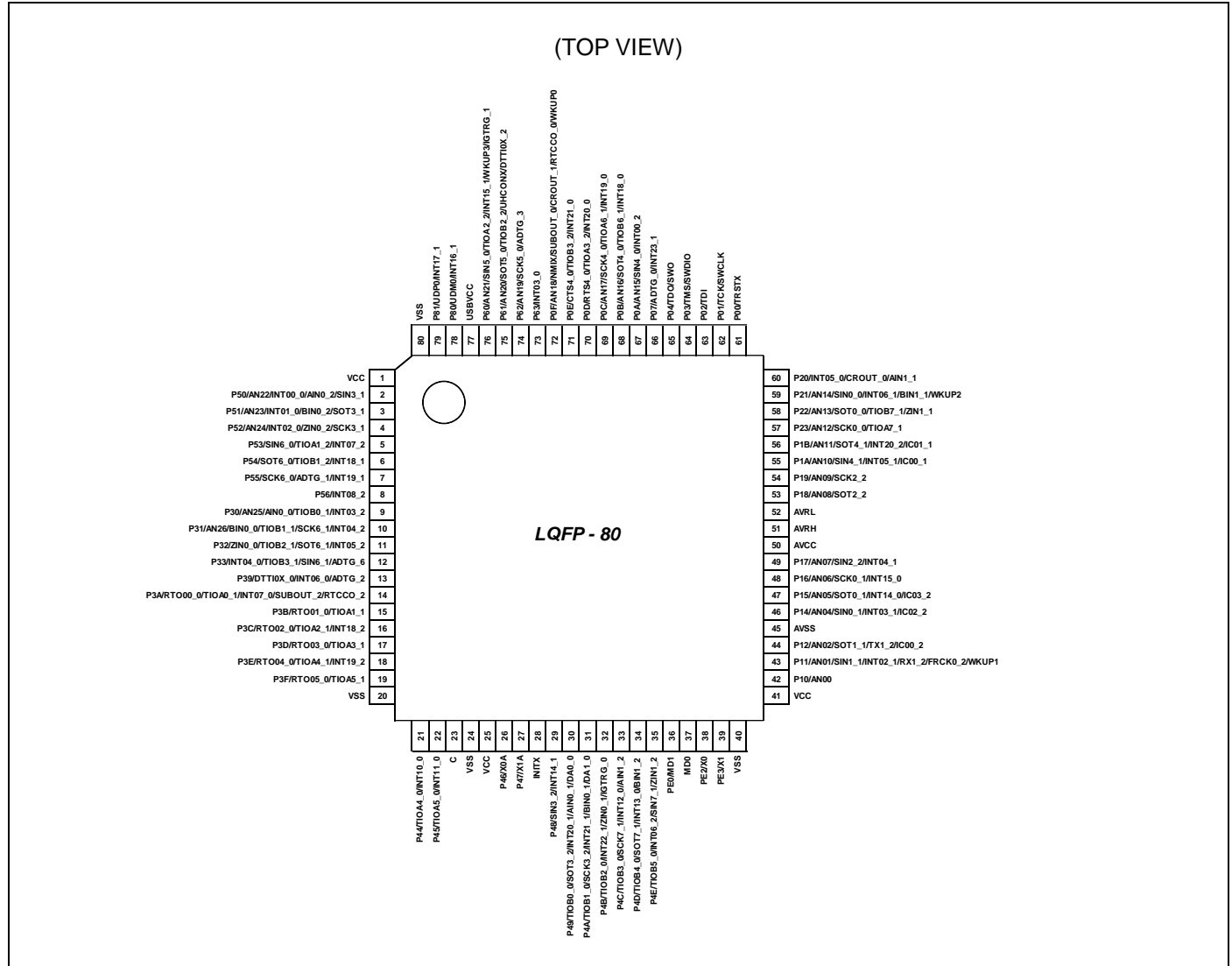

**Note:**

- The number after the underscore ("\_") in pin names such as XXX\_1 and XXX\_2 indicates the relocated port number. For these pins, there are multiple pins that provide the same function for the same channel. Use the extended port function register (EPFR) to select the pin.

LQD064/LQG064

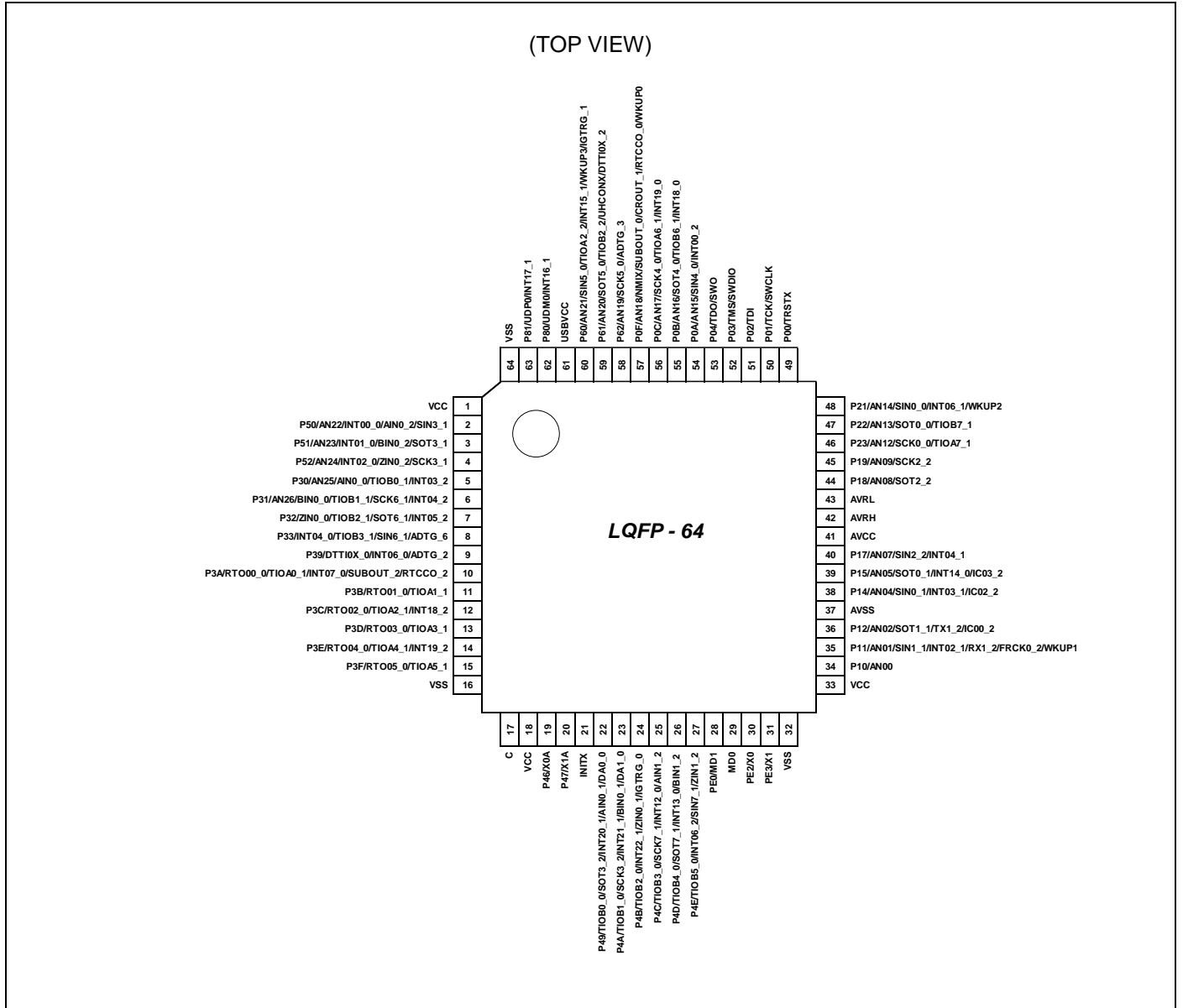

**Note:**

- The number after the underscore ("\_") in pin names such as XXX\_1 and XXX\_2 indicates the relocated port number. For these pins, there are multiple pins that provide the same function for the same channel. Use the extended port function register (EPFR) to select the pin.

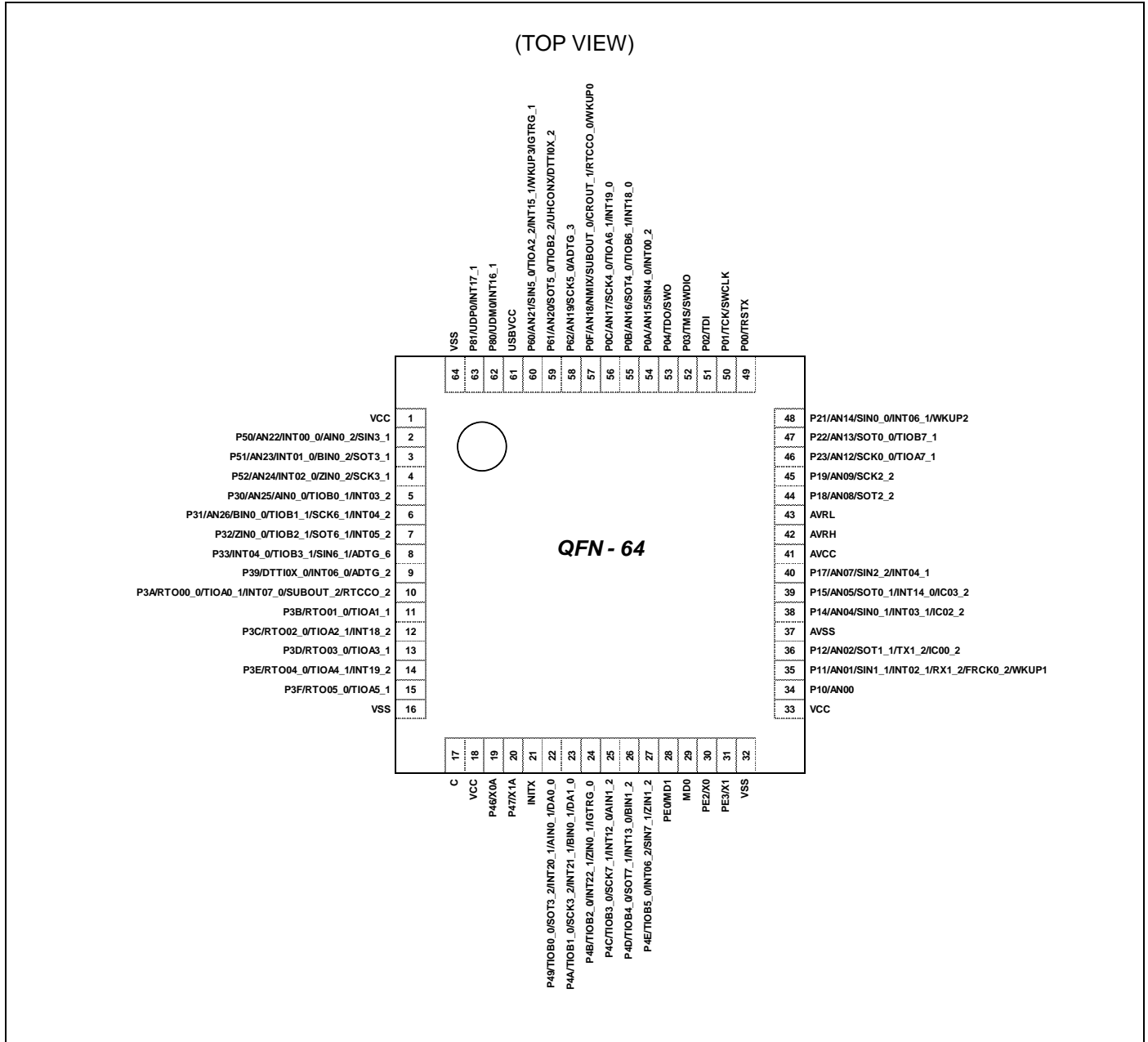
**VNC064**

**Note:**

- The number after the underscore ("\_") in pin names such as XXX\_1 and XXX\_2 indicates the relocated port number. For these pins, there are multiple pins that provide the same function for the same channel. Use the extended port function register (EPFR) to select the pin.

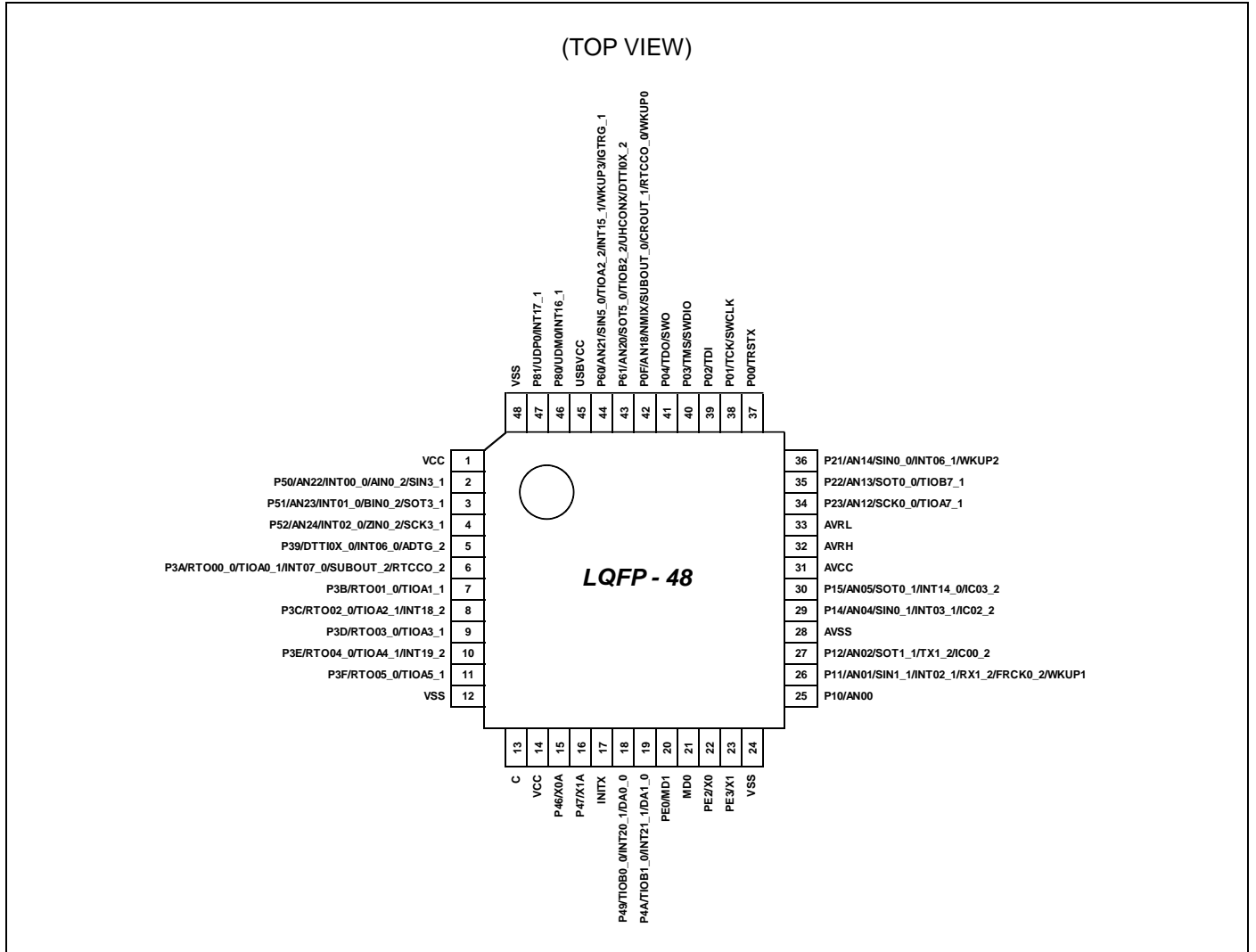
LQA048



**Note:**

- The number after the underscore ("\_") in pin names such as XXX\_1 and XXX\_2 indicates the relocated port number. For these pins, there are multiple pins that provide the same function for the same channel. Use the extended port function register (EPFR) to select the pin.

VNA048

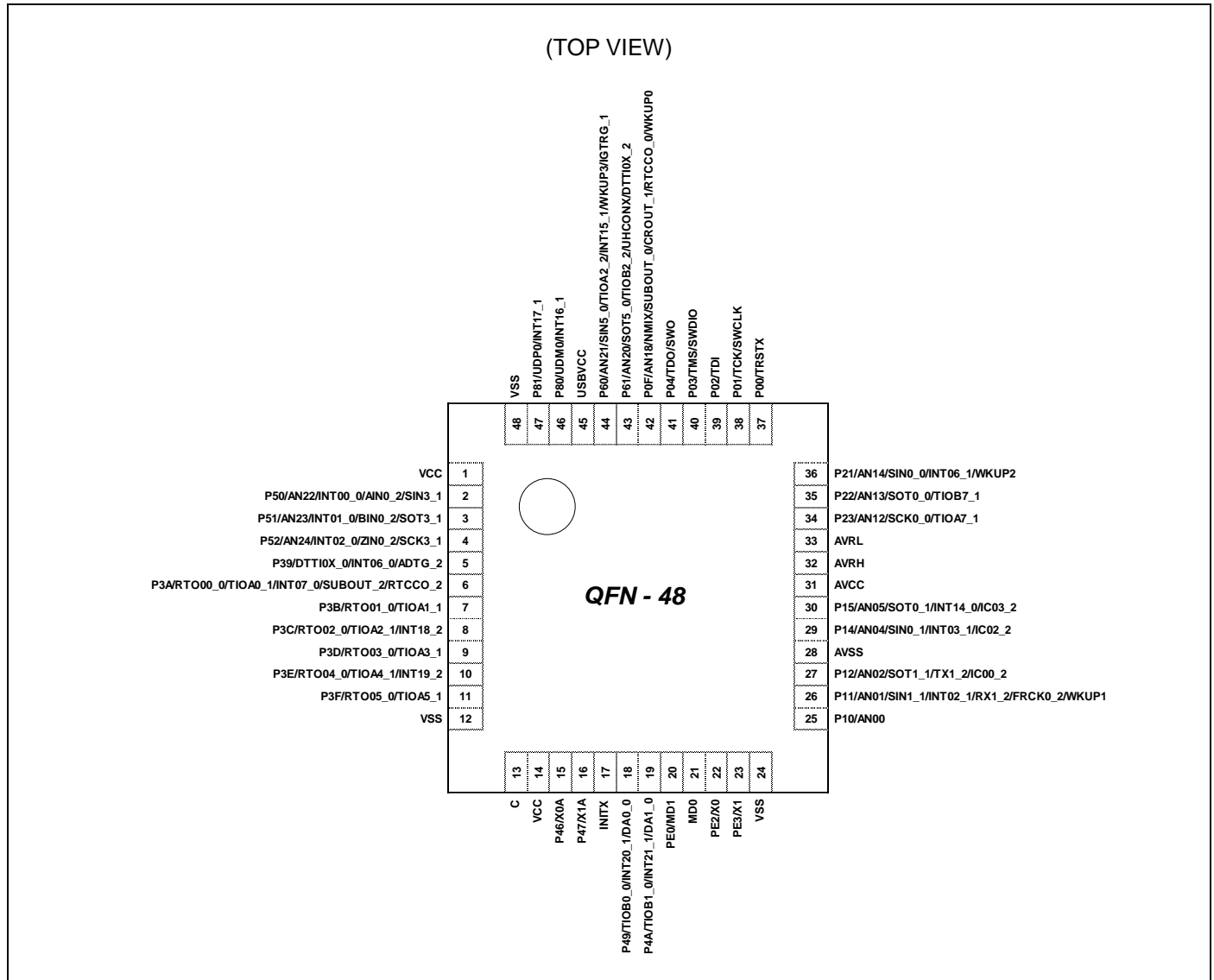

**Note:**

- The number after the underscore ("\_") in pin names such as XXX\_1 and XXX\_2 indicates the relocated port number. For these pins, there are multiple pins that provide the same function for the same channel. Use the extended port function register (EPFR) to select the pin.

FDG096

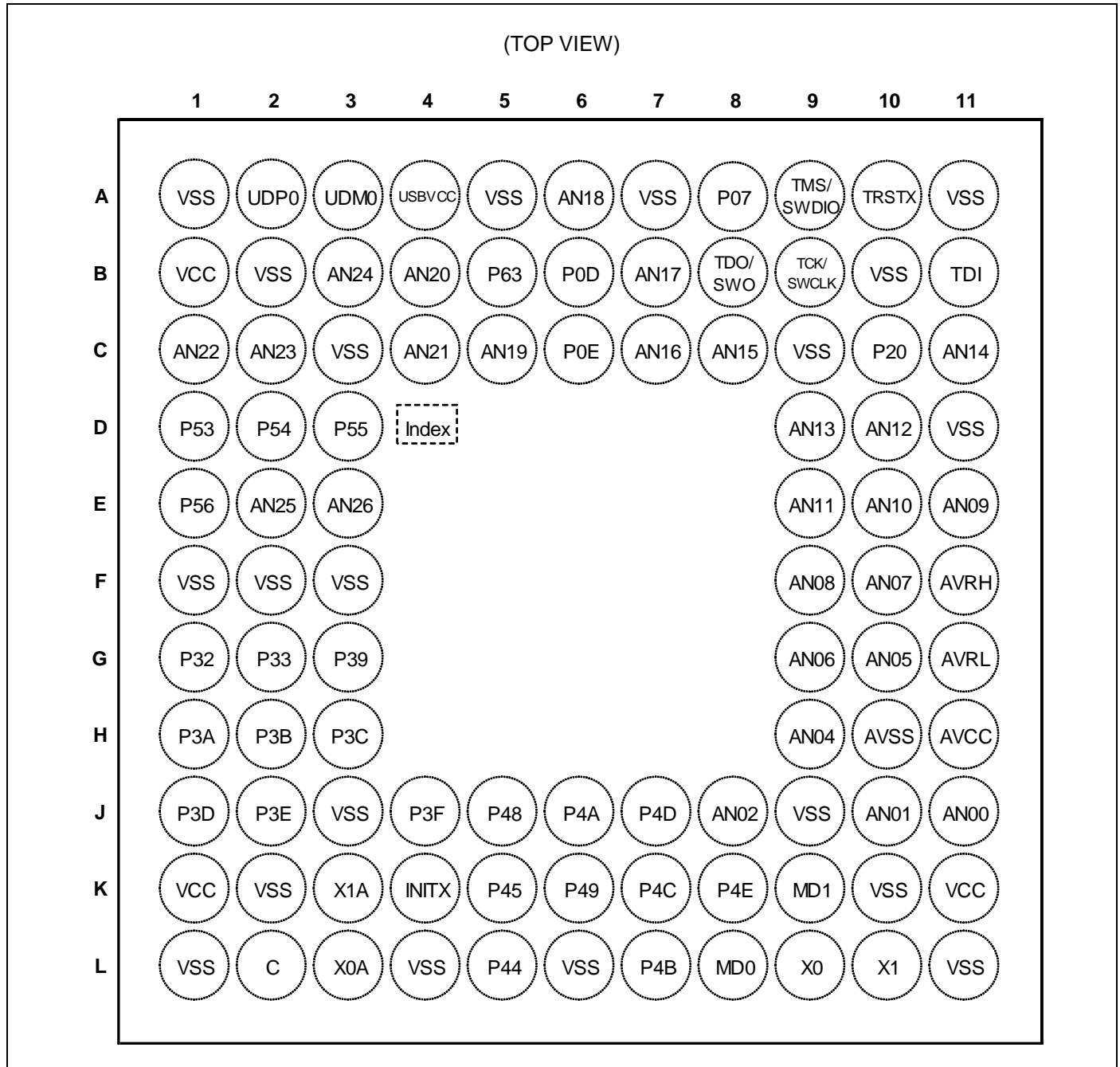

**Note:**

- The number after the underscore ("\_") in pin names such as XXX\_1 and XXX\_2 indicates the relocated port number. For these pins, there are multiple pins that provide the same function for the same channel. Use the extended port function register (EPFR) to select the pin.

#### 4. List of Pin Functions

##### List of pin numbers

The number after the underscore ("\_") in pin names such as XXX\_1 and XXX\_2 indicates the relocated port number. For these pins, there are multiple pins that provide the same function for the same channel. Use the extended port function register (EPFR) to select the pin.

Pin No				Pin Name	I/O circuit type	Pin state type
LQFP-80	BGA-96	LQFP-64 QFN-64	LQFP-48 QFN-48			
1	B1	1	1	VCC	-	
2	C1	2	2	P50	F	N
				INT00_0		
				AIN0_2		
				SIN3_1		
3	C2	3	3	AN22	F	N
				P51		
				INT01_0		
				BIN0_2		
4	B3	4	4	SOT3_1 (SDA3_1)	F	N
				AN23		
				P52		
				INT02_0		
5	D1	-	-	ZIN0_2	E	L
				SCK3_1 (SCL3_1)		
				AN24		
				P53		
6	D2	-	-	SIN6_0	E	L
				TIOA1_2		
				INT07_2		
				P54		
7	D3	-	-	SOT6_0 (SDA6_0)	E	L
				TIOB1_2		
				INT18_1		
				P55		
8	E1	-	-	SCK6_0 (SCL6_0)	E	L
				ADTG_1		
				INT19_1		
				P56		
9	E2	5	-	INT08_2	F	N
				P30		
				AIN0_0		
				TIOB0_1		
				INT03_2		
				AN25		

Pin No				Pin Name	I/O circuit type	Pin state type
LQFP-80	BGA-96	LQFP-64 QFN-64	LQFP-48 QFN-48			
10	E3	6	-	P31	F	N
				BIN0_0		
				TIOB1_1		
				SCK6_1 (SCL6_1)		
				INT04_2		
				AN26		
11	G1	7	-	P32	E	L
				ZIN0_0		
				TIOB2_1		
				SOT6_1 (SDA6_1)		
				INT05_2		
12	G2	8	-	P33	E	L
				INT04_0		
				TIOB3_1		
				SIN6_1		
				ADTG_6		
13	G3	9	5	P39	E	L
				DTTIOX_0		
				INT06_0		
				ADTG_2		
14	H1	10	6	P3A	G	L
				RTO00_0 (PPG00_0)		
				TIOA0_1		
				INT07_0		
				SUBOUT_2		
RTCCO_2						
15	H2	11	7	P3B	G	K
				RTO01_0 (PPG00_0)		
				TIOA1_1		
16	H3	12	8	P3C	G	L
				RTO02_0 (PPG02_0)		
				TIOA2_1		
				INT18_2		
17	J1	13	9	P3D	G	K
				RTO03_0 (PPG02_0)		
				TIOA3_1		

Pin No				Pin Name	I/O circuit type	Pin state type
LQFP-80	BGA-96	LQFP-64 QFN-64	LQFP-48 QFN-48			
18	J2	14	10	P3E	G	L
				RTO04_0 (PPG04_0)		
				TIOA4_1		
				INT19_2		
19	J4	15	11	P3F	G	K
				RTO05_0 (PPG04_0)		
				TIOA5_1		
20	L1	16	12	VSS	-	
21	L5	-	-	P44	G	L
				TIOA4_0		
				INT10_0		
22	K5	-	-	P45	G	L
				TIOA5_0		
				INT11_0		
23	L2	17	13	C	-	
24	L4	-	-	VSS	-	
25	K1	18	14	VCC	-	
26	L3	19	15	P46	D	F
				X0A		
27	K3	20	16	P47	D	G
				X1A		
28	K4	21	17	INITX	B	C
29	J5	-	-	P48	E	L
				INT14_1		
				SIN3_2		
30	K6	22	18	P49	L	L
				TIOB0_0		
				INT20_1		
			DA0_0			
			-	SOT3_2 (SDA3_2)		
-	AIN0_1					
31	J6	23	19	P4A	L	L
				TIOB1_0		
				INT21_1		
				DA1_0		
			-	SCK3_2 (SCL3_2)		
			-	BIN0_1		

Pin No				Pin Name	I/O circuit type	Pin state type
LQFP-80	BGA-96	LQFP-64 QFN-64	LQFP-48 QFN-48			
32	L7	24	-	P4B	E	L
				TIOB2_0		
				INT22_1		
				IGTRG_0		
33	K7	25	-	ZIN0_1	I*	L
				P4C		
				TIOB3_0		
				SCK7_1 (SCL7_1)		
34	J7	26	-	INT12_0	I*	L
				AIN1_2		
				P4D		
				TIOB4_0		
35	K8	27	-	SOT7_1 (SDA7_1)	I*	L
				INT13_0		
				BIN1_2		
				P4E		
36	K9	28	20	TIOB5_0	I*	L
				INT06_2		
				SIN7_1		
				ZIN1_2		
37	L8	29	21	MD1	C	E
				PE0		
38	L9	30	22	MD0	A	A
				PE2		
39	L10	31	23	X0	A	B
				PE3		
40	L11	32	24	VSS	-	
41	K11	33	-	VCC	-	
42	J11	34	25	P10	F	M
				AN00		
43	J10	35	26	P11	F	N
				AN01		
				SIN1_1		
				INT02_1		
				RX1_2		
				FRCK0_2		
WKUP1						
44	J8	36	27	P12	F	M
				AN02		
				SOT1_1 (SDA1_1)		
				TX1_2		
				IC00_2		

Pin No				Pin Name	I/O circuit type	Pin state type
LQFP-80	BGA-96	LQFP-64 QFN-64	LQFP-48 QFN-48			
45	H10	37	28	AVSS	-	
46	H9	38	29	P14	F	N
				AN04		
				INT03_1		
				IC02_2		
47	G10	39	30	SIN0_1	F	N
				P15		
				AN05		
				IC03_2		
48	G9	-	-	SOT0_1 (SDA0_1)	F	N
				INT14_0		
				P16		
				AN06		
49	F10	40	-	SCK0_1 (SCL0_1)	F	N
				INT15_0		
				P17		
				AN07		
50	H11	41	31	SIN2_2	F	N
				INT04_1		
				AVCC		
51	F11	42	32	AVRH	-	
52	G11	43	33	AVRL	-	
53	F9	44	-	P18	F	M
				AN08		
				SOT2_2 (SDA2_2)		
54	E11	45	-	P19	F	M
				AN09		
				SCK2_2 (SCL2_2)		
55	E10	-	-	P1A	F	N
				AN10		
				SIN4_1		
				INT05_1		
				IC00_1		

Pin No				Pin Name	I/O circuit type	Pin state type
LQFP-80	BGA-96	LQFP-64 QFN-64	LQFP-48 QFN-48			
56	E9	-	-	P1B	F	N
				AN11		
				SOT4_1 (SDA4_1)		
				IC01_1		
				INT20_2		
57	D10	46	34	P23	F	M
				SCK0_0 (SCL0_0)		
				TIOA7_1		
				AN12		
58	D9	47	35	P22	F	M
				SOT0_0 (SDA0_0)		
				TIOB7_1		
		AN13				
		-	-	ZIN1_1		
59	C11	48	36	P21	F	N
				SIN0_0		
				INT06_1		
				WKUP2		
				BIN1_1		
				AN14		
60	C10	-	-	P20	E	N
				INT05_0		
				CROUT_0		
				AIN1_1		
61	A10	49	37	P00	E	J
				TRSTX		
62	B9	50	38	P01	E	J
				TCK		
				SWCLK		
63	B11	51	39	P02	E	J
				TDI		
64	A9	52	40	P03	E	J
				TMS		
				SWDIO		
65	B8	53	41	P04	E	J
				TDO		
				SWO		
66	A8	-	-	P07	E	L
				ADTG_0		
				INT23_1		

Pin No				Pin Name	I/O circuit type	Pin state type
LQFP-80	BGA-96	LQFP-64 QFN-64	LQFP-48 QFN-48			
67	C8	54	-	P0A	J*	N
				SIN4_0		
				INT00_2		
				AN15		
68	C7	55	-	P0B	J*	N
				SOT4_0 (SDA4_0)		
				TIOB6_1		
				AN16		
69	B7	56	-	P0C	J*	N
				SCK4_0 (SCL4_0)		
				TIOA6_1		
				INT19_0		
70	B6	-	-	P0D	E	L
				RTS4_0		
				TIOA3_2		
				INT20_0		
71	C6	-	-	P0E	E	L
				CTS4_0		
				TIOB3_2		
				INT21_0		
72	A6	57	42	P0F	F	I
				NMIX		
				SUBOUT_0		
				CROUT_1		
				RTCCO_0		
				WKUP0		
AN18						
73	B5	-	-	P63	E	L
				INT03_0		
74	C5	58	-	P62	F	M
				SCK5_0 (SCL5_0)		
				ADTG_3		
				AN19		
75	B4	59	43	P61	F	M
				SOT5_0 (SDA5_0)		
				TIOB2_2		
				UHCONX		
				DTTIOX_2		
AN20						

Pin No				Pin Name	I/O circuit type	Pin state type
LQFP-80	BGA-96	LQFP-64 QFN-64	LQFP-48 QFN-48			
76	C4	60	44	P60	J*	N
				SIN5_0		
				TIOA2_2		
				INT15_1		
				WKUP3		
				IGTRG_1		
AN21						
77	A4	61	45	USBVCC	-	
78	A3	62	46	P80	H	H
				UDM0		
				INT16_1		
79	A2	63	47	P81	H	H
				UDP0		
				INT17_1		
80	A1	64	48	VSS	-	
-	A5, A7, A11, B2, B10, C3, C9, D11, F1, F2, F3, J3, J9, K2, K10, L6	-	-	VSS	-	

\*: 5 V tolerant I/O

**List of pin functions**

The number after the underscore ("\_") in pin names such as XXX\_1 and XXX\_2 indicates the relocated port number. For these pins, there are multiple pins that provide the same function for the same channel. Use the extended port function register (EPFR) to select the pin.

Pin function	Pin name	Function description	Pin No			
			LQFP-80	BGA-96	LQFP-64 QFN-64	LQFP-48 QFN-48
ADC	ADTG_0	A/D converter external trigger input pin	66	A8	-	-
	ADTG_1		7	D3	-	-
	ADTG_2		13	G3	9	5
	ADTG_3		74	C5	58	-
	ADTG_6		12	G2	8	-
	AN00		42	J11	34	25
	AN01	43	J10	35	26	
	AN02	44	J8	36	27	
	AN04	46	H9	38	29	
	AN05	47	G10	39	30	
	AN06	48	G9	-	-	
	AN07	49	F10	40	-	
	AN08	53	F9	44	-	
	AN09	54	E11	45	-	
	AN10	55	E10	-	-	
	AN11	56	E9	-	-	
	AN12	57	D10	46	34	
	AN13	58	D9	47	35	
	AN14	59	C11	48	36	
	AN15	67	C8	54	-	
	AN16	68	C7	55	-	
	AN17	69	B7	56	-	
	AN18	72	A6	57	42	
	AN19	74	C5	58	-	
	AN20	75	B4	59	43	
	AN21	76	C4	60	44	
	AN22	2	C1	2	2	
	AN23	3	C2	3	3	
	AN24	4	B3	4	4	
	AN25	9	E2	5	-	
AN26	10	E3	6	-		
		A/D converter analog input pin. ANxx describes ADC ch.xx.				

Pin function	Pin name	Function description	Pin No			
			LQFP-80	BGA-96	LQFP-64 QFN-64	LQFP-48 QFN-48
Base Timer 0	TIOA0_1	Base timer ch.0 TIOA pin	14	H1	10	6
	TIOB0_0	Base timer ch.0 TIOB pin	30	K6	22	18
	TIOB0_1		9	E2	5	-
Base Timer 1	TIOA1_1	Base timer ch.1 TIOA pin	15	H2	11	7
	TIOA1_2		5	D1	-	-
	TIOB1_0	Base timer ch.1 TIOB pin	31	J6	23	19
	TIOB1_1		10	E3	6	-
	TIOB1_2		6	D2	-	-
Base Timer 2	TIOA2_1	Base timer ch.2 TIOA pin	16	H3	12	8
	TIOA2_2		76	C4	60	44
	TIOB2_0	Base timer ch.2 TIOB pin	32	L7	24	-
	TIOB2_1		11	G1	7	-
	TIOB2_2		75	B4	59	43
Base Timer 3	TIOA3_1	Base timer ch.3 TIOA pin	17	J1	13	9
	TIOA3_2		70	B6	-	-
	TIOB3_0	Base timer ch.3 TIOB pin	33	K7	25	-
	TIOB3_1		12	G2	8	-
	TIOB3_2		71	C6	-	-
Base Timer 4	TIOA4_0	Base timer ch.4 TIOA pin	21	L5	-	-
	TIOA4_1	Base timer ch.4 TIOB pin	18	J2	14	10
	TIOB4_0		34	J7	26	-
Base Timer 5	TIOA5_0	Base timer ch.5 TIOA pin	22	K5	-	-
	TIOA5_1		19	J4	15	11
	TIOB5_0	Base timer ch.5 TIOB pin	35	K8	27	-
Base Timer 6	TIOA6_1	Base timer ch.6 TIOA pin	69	B7	56	-
	TIOB6_1	Base timer ch.6 TIOB pin	68	C7	55	-
Base Timer 7	TIOA7_1	Base timer ch.7 TIOA pin	57	D10	46	34
	TIOB7_1	Base timer ch.7 TIOB pin	58	D9	47	35
Debugger	SWCLK	Serial wire debug interface clock input pin	62	B9	50	38
	SWDIO	Serial wire debug interface data input / output pin	64	A9	52	40
	SWO	Serial wire viewer output pin	65	B8	53	41
	TCK	JTAG test clock input pin	62	B9	50	38
	TDI	JTAG test data input pin	63	B11	51	39
	TDO	JTAG debug data output pin	65	B8	53	41
	TMS	JTAG test mode state input/output pin	64	A9	52	40
	TRSTX	JTAG test reset input pin	61	A10	49	37

Pin function	Pin name	Function description	Pin No			
			LQFP-80	BGA-96	LQFP-64 QFN-64	LQFP-48 QFN-48
External Interrupt	INT00_0	External interrupt request 00 input pin	2	C1	2	2
	INT00_2		67	C8	54	-
	INT01_0	External interrupt request 01 input pin	3	C2	3	3
	INT02_0	External interrupt request 02 input pin	4	B3	4	4
	INT02_1		43	J10	35	26
	INT03_0	External interrupt request 03 input pin	73	B5	-	-
	INT03_1		46	H9	38	29
	INT03_2		9	E2	5	-
	INT04_0	External interrupt request 04 input pin	12	G2	8	-
	INT04_1		49	F10	40	-
	INT04_2		10	E3	6	-
	INT05_0	External interrupt request 05 input pin	60	P20	-	-
	INT05_1		55	E10	-	-
	INT05_2		11	G1	7	-
	INT06_0	External interrupt request 06 input pin	13	G3	9	5
	INT06_1		59	C11	48	36
	INT06_2		35	K8	27	-
	INT07_0	External interrupt request 07 input pin	14	H1	10	6
	INT07_2		5	D1	-	-
	INT08_2	External interrupt request 08 input pin	8	E1	-	-
	INT10_0	External interrupt request 10 input pin	21	L5	-	-
	INT11_0	External interrupt request 11 input pin	22	K5	-	-
	INT12_0	External interrupt request 12 input pin	33	K7	25	-
	INT13_0	External interrupt request 13 input pin	34	J7	26	-
	INT14_0	External interrupt request 14 input pin	47	G10	39	30
	INT14_1		29	J5	-	-
	INT15_0	External interrupt request 15 input pin	48	G9	-	-
	INT15_1		76	C4	60	44
	INT16_1	External interrupt request 16 input pin	78	A3	62	46
	INT17_1	External interrupt request 17 input pin	79	A2	63	47
INT18_0	External interrupt request 18 input pin	68	C7	55	-	
INT18_1		6	D2	-	-	
INT18_2		16	H3	12	8	
INT19_0	External interrupt request 19 input pin	59	C11	56	-	
INT19_1		7	D3	-	-	
INT19_2		18	J2	14	10	

Pin function	Pin name	Function description	Pin No			
			LQFP-80	BGA-96	LQFP-64 QFN-64	LQFP-48 QFN-48
External Interrupt	INT20_0	External interrupt request 20 input pin	70	B6	-	-
	INT20_1		30	K6	22	18
	INT20_2		56	E9	-	-
	INT21_0	External interrupt request 21 input pin	71	C6	-	-
	INT21_1		31	J6	23	19
	INT22_1	External interrupt request 22 input pin	32	L7	24	-
	INT23_1	External interrupt request 23 input pin	66	A8	-	-
NMIX	Non-Maskable Interrupt input pin	72	A6	57	42	
GPIO	P00	General-purpose I/O port 0	61	A10	49	37
	P01		62	B9	50	38
	P02		63	B11	51	39
	P03		64	A9	52	40
	P04		65	B8	53	41
	P07		66	A8	-	-
	P0A		67	C8	54	-
	P0B		68	C7	55	-
	P0C		69	B7	56	-
	P0D		70	B6	-	-
	P0E		71	C6	-	-
	P0F		72	A6	57	42
	P10		General-purpose I/O port 1	42	J11	34
	P11	43		J10	35	26
	P12	44		J8	36	27
	P14	46		H9	38	29
	P15	47		G10	39	30
	P16	48		G9	-	-
	P17	49		F10	40	-
	P18	53		F9	44	-
	P19	54		E11	45	-
	P1A	55		E10	-	-
	P1B	56	E9	-	-	
P20	General-purpose I/O port 2	60	C10	-	-	
P21		59	C11	48	36	
P22		58	D9	47	35	
P23		57	D10	46	34	

Pin function	Pin name	Function description	Pin No			
			LQFP-80	BGA-96	LQFP-64 QFN-64	LQFP-48 QFN-48
GPIO	P30	General-purpose I/O port 3	9	E2	5	-
	P31		10	E3	6	-
	P32		11	G1	7	-
	P33		12	G2	8	-
	P39		13	G3	9	5
	P3A		14	H1	10	6
	P3B		15	H2	11	7
	P3C		16	H3	12	8
	P3D		17	J1	13	9
	P3E		18	J2	14	10
	P3F		19	J4	15	11
	P44		General-purpose I/O port 4	21	L5	-
	P45	22		K5	-	-
	P46	26		L3	19	15
	P47	27		K3	20	16
	P48	29		J5	-	-
	P49	30		K6	22	18
	P4A	31		J6	23	19
	P4B	32		L7	24	-
	P4C	33		K7	25	-
	P4D	34		J7	26	-
	P4E	35		K8	27	-
	P50	General-purpose I/O port 5		2	C1	2
	P51		3	C2	3	3
	P52		4	B3	4	4
	P53		5	D1	-	-
	P54		6	D2	-	-
	P55		7	D3	-	-
	P56		8	E1	-	-
	P60		General-purpose I/O port 6	76	C4	60
	P61	75		B4	59	43
	P62	74		C5	58	-
	P63	73		B5	-	-
	P80	General-purpose I/O port 8	78	A3	62	46
	P81		79	A2	63	47
	PE0	General-purpose I/O port E	36	K9	28	20
	PE2		38	L9	30	22
	PE3		39	L10	31	23

Pin function	Pin name	Function description	Pin No			
			LQFP-80	BGA-96	LQFP-64 QFN-64	LQFP-48 QFN-48
Multi-function Serial 0	SIN0_0	Multi-function serial interface ch.0 input pin	59	C11	48	36
	SIN0_1		46	H9	38	29
	SOT0_0 (SDA0_0)	Multi-function serial interface ch.0 output pin. This pin operates as SOT0 when it is used in a UART/CSIO/LIN (operation modes 0 to 3) and as SDA0 when it is used in an I <sup>2</sup> C (operation mode 4).	58	D9	47	35
	SOT0_1 (SDA0_1)		47	G10	39	30
	SCK0_0 (SCL0_0)	Multi-function serial interface ch.0 clock I/O pin. This pin operates as SCK0 when it is used in a CSIO (operation mode 2) and as SCL0 when it is used in an I <sup>2</sup> C (operation mode 4).	57	D10	46	34
	SCK0_1 (SCL0_1)		48	G9	-	-
Multi-function Serial 1	SIN1_1	Multi-function serial interface ch.1 input pin	43	J10	35	26
	SOT1_1 (SDA1_1)	Multi-function serial interface ch.1 output pin. This pin operates as SOT1 when it is used in a UART/LIN (operation modes 0,1,3) .	44	J8	36	27
Multi-function Serial 2	SIN2_2	Multi-function serial interface ch.2 input pin	49	F10	40	-
	SOT2_2 (SDA2_2)	Multi-function serial interface ch.2 output pin. This pin operates as SOT2 when it is used in a UART/CSIO/LIN (operation modes 0 to 3) and as SDA2 when it is used in an I <sup>2</sup> C (operation mode 4).	53	F9	44	-
	SCK2_2 (SCL2_2)	Multi-function serial interface ch.2 clock I/O pin. This pin operates as SCK2 when it is used in a CSIO (operation mode 2) and as SCL2 when it is used in an I <sup>2</sup> C (operation mode 4).	54	E11	45	-
Multi-function Serial 3	SIN3_1	Multi-function serial interface ch.3 input pin	2	C1	2	2
	SIN3_2		29	J5	-	-
	SOT3_1 (SDA3_1)	Multi-function serial interface ch.3 output pin. This pin operates as SOT3 when it is used in a UART/CSIO/LIN (operation modes 0 to 3) and as SDA3 when it is used in an I <sup>2</sup> C (operation mode 4).	3	C2	3	3
	SOT3_2 (SDA3_2)		30	K6	-	-
	SCK3_1 (SCL3_1)	Multi-function serial interface ch.3 clock I/O pin. This pin operates as SCK3 when it is used in a CSIO (operation mode 2) and as SCL3 when it is used in an I <sup>2</sup> C (operation mode 4).	4	B3	4	4
	SCK3_2 (SCL3_2)		31	J6	-	-

Pin function	Pin name	Function description	Pin No			
			LQFP-80	BGA-96	LQFP-64 QFN-64	LQFP-48 QFN-48
Multi-function Serial 4	SIN4_0	Multi-function serial interface ch.4 input pin	67	C8	54	-
	SIN4_1		55	E10	-	-
	SOT4_0 (SDA4_0)	Multi-function serial interface ch.4 output pin. This pin operates as SOT4 when it is used in a UART/CSIO/LIN (operation modes 0 to 3) and as SDA4 when it is used in an I <sup>2</sup> C (operation mode 4).	68	C7	55	-
	SOT4_1 (SDA4_1)		56	E9	-	-
	SCK4_0 (SCL4_0)	Multi-function serial interface ch.4 clock I/O pin. This pin operates as SCK4 when it is used in a CSIO (operation mode 2) and as SCL4 when it is used in an I <sup>2</sup> C (operation mode 4).	69	B7	56	-
	RTS4_0	Multi-function serial interface ch.4 RTS output pin	70	B6	-	-
CTS4_0	Multi-function serial interface ch.4 CTS input pin	71	C6	-	-	
Multi-function Serial 5	SIN5_0	Multi-function serial interface ch.5 input pin	76	C4	60	44
	SOT5_0 (SDA5_0)	Multi-function serial interface ch.5 output pin. This pin operates as SOT5 when it is used in a UART/CSIO/LIN (operation modes 0 to 3) and as SDA5 when it is used in an I <sup>2</sup> C (operation mode 4).	75	B4	59	43
	SCK5_0 (SCL5_0)	Multi-function serial interface ch.5 clock I/O pin. This pin operates as SCK5 when it is used in a CSIO (operation mode 2) and as SCL5 when it is used in an I <sup>2</sup> C (operation mode 4).	74	C5	58	-
Multi-function Serial 6	SIN6_0	Multi-function serial interface ch.6 input pin	5	D1	-	-
	SIN6_1		12	G2	8	-
	SOT6_0 (SDA6_0)	Multi-function serial interface ch.6 output pin. This pin operates as SOT6 when it is used in a UART/CSIO/LIN (operation modes 0 to 3) and as SDA6 when it is used in an I <sup>2</sup> C (operation mode 4).	6	D2	-	-
	SOT6_1 (SDA6_1)		11	G1	7	-
	SCK6_0 (SCL6_0)	Multi-function serial interface ch.6 clock I/O pin. This pin operates as SCK6 when it is used in a CSIO (operation mode 2) and as SCL6 when it is used in an I <sup>2</sup> C (operation mode 4).	7	D3	-	-
	SCK6_1 (SCL6_1)		10	E3	6	-

Pin function	Pin name	Function description	Pin No			
			LQFP-80	BGA-96	LQFP-64 QFN-64	LQFP-48 QFN-48
Multi-function Serial 7	SIN7_1	Multi-function serial interface ch.7 input pin	35	K8	27	-
	SOT7_1 (SDA7_1)	Multi-function serial interface ch.7 output pin. This pin operates as SOT7 when it is used in a UART/CSIO/LIN (operation modes 0 to 3) and as SDA7 when it is used in an I <sup>2</sup> C (operation mode 4).	34	J7	26	-
	SCK7_1 (SCL7_1)	Multi-function serial interface ch.7 clock I/O pin. This pin operates as SCK7 when it is used in a CSIO (operation mode 2) and as SCL7 when it is used in an I <sup>2</sup> C (operation mode 4).	33	K7	25	-
Multi-function Timer 0	DTT10X_0	Input signal of waveform generator to control outputs RTO00 to RTO05 of Multi-function timer 0.	13	G3	9	5
	DTT10X_2		75	B4	59	43
	FRCK0_2	16-bit free-run timer ch.0 external clock input pin	43	J10	35	26
	IC00_1	16-bit input capture input pin of Multi-function timer 0. ICxx describes channel number.	55	E10	-	-
	IC00_2		44	J8	36	27
	IC01_1		56	E9	-	-
	IC02_2		46	H9	38	29
	IC03_2		47	G10	39	30
	RTO00_0 (PPG00_0)		Waveform generator output pin of Multi-function timer 0. This pin operates as PPG00 when it is used in PPG0 output mode.	14	H1	10
	RTO01_0 (PPG00_0)	Waveform generator output pin of Multi-function timer 0. This pin operates as PPG00 when it is used in PPG0 output mode.	15	H2	11	7
	RTO02_0 (PPG02_0)	Waveform generator output pin of Multi-function timer 0. This pin operates as PPG02 when it is used in PPG0 output mode.	16	H3	12	8
	RTO03_0 (PPG02_0)	Waveform generator output pin of Multi-function timer 0. This pin operates as PPG02 when it is used in PPG0 output mode.	17	J1	13	9
	RTO04_0 (PPG04_0)	Waveform generator output pin of Multi-function timer 0. This pin operates as PPG04 when it is used in PPG0 output mode.	18	J2	14	10
	RTO05_0 (PPG04_0)	Waveform generator output pin of Multi-function timer 0. This pin operates as PPG04 when it is used in PPG0 output mode.	19	J4	15	11
	IGTRG_0	PPG IGBT mode external trigger input pin	32	L7	24	-
IGTRG_1	76		C4	60	44	

Pin function	Pin name	Function description	Pin No			
			LQFP-80	BGA-96	LQFP-64 QFN-64	LQFP-48 QFN-48
Quadrature Position/ Revolution Counter 0	AIN0_0	QPRC ch.0 AIN input pin	9	E2	5	-
	AIN0_1		30	K6	22	-
	AIN0_2		2	C1	2	2
	BIN0_0	QPRC ch.0 BIN input pin	10	E3	6	-
	BIN0_1		31	J6	23	-
	BIN0_2		3	C2	3	3
	ZIN0_0	QPRC ch.0 ZIN input pin	11	G1	7	-
	ZIN0_1		32	L7	24	-
ZIN0_2	4		B3	4	4	
Quadrature Position/ Revolution Counter 1	AIN1_1	QPRC ch.1 AIN input pin	60	C10	-	-
	AIN1_2		33	K7	25	-
	BIN1_1	QPRC ch.1 BIN input pin	59	C11	-	-
	BIN1_2		34	J7	26	-
	ZIN1_1	QPRC ch.1 ZIN input pin	58	D9	-	-
	ZIN1_2		35	K8	27	-
USB	UDM0	USB device/host D – pin	78	A3	62	46
	UDP0	USB device/host D + pin	79	A2	63	47
	UHCONX	USB external pull-up control pin	75	B4	59	43
CAN	TX1_2	CAN interface TX output pin	44	J8	36	27
	RX1_2	CAN interface RX input pin	43	J10	35	26
Real-time clock	RTCCO_0	0.5 seconds pulse output pin of Real-time clock	72	A6	57	42
	RTCCO_2		14	H1	10	6
	SUBOUT_0	Sub clock output pin	72	A6	57	42
	SUBOUT_2		14	H1	10	6
Low-Power Consumption Mode	WKUP0	Deep standby mode return signal input pin 0	72	A6	57	42
	WKUP1	Deep standby mode return signal input pin 1	43	J10	35	26
	WKUP2	Deep standby mode return signal input pin 2	59	C11	48	36
	WKUP3	Deep standby mode return signal input pin 3	76	C4	60	44
DAC	DA0	D/A converter ch.0 analog output pin	30	K6	22	18
	DA1	D/A converter ch.1 analog output pin	31	J6	23	19
Reset	INITX	External Reset Input pin. A reset is valid when INITX="L".	28	K4	21	17

Pin function	Pin name	Function description	Pin No			
			LQFP-80	BGA-96	LQFP-64 QFN-64	LQFP-48 QFN-48
Mode	MD0	Mode 0 pin. During normal operation, MD0="L" must be input. During serial programming to Flash memory, MD0="H" must be input.	37	L8	29	21
	MD1	Mode 1 pin. During serial programming to Flash memory, MD1="L" must be input.	36	K9	28	20
Power	VCC	Power supply Pin	1	B1	1	1
	VCC	Power supply Pin	25	K1	18	14
	VCC	Power supply Pin	41	K11	33	-
	USBVCC	3.3V Power supply port for USB I/O	77	A4	61	45
GND	VSS	GND Pin	-	F1	-	-
	VSS	GND Pin	-	F2	-	-
	VSS	GND Pin	-	F3	-	-
	VSS	GND Pin	-	B2	-	-
	VSS	GND Pin	20	L1	16	12
	VSS	GND Pin	-	K2	-	-
	VSS	GND Pin	-	J3	-	-
	VSS	GND Pin	-	L6	-	-
	VSS	GND Pin	24	L4	-	-
	VSS	GND Pin	40	L11	32	24
	VSS	GND Pin	-	K10	-	-
	VSS	GND Pin	-	J9	-	-
	VSS	GND Pin	-	B10	-	-
	VSS	GND Pin	-	C9	-	-
	VSS	GND Pin	-	D11	-	-
	VSS	GND Pin	-	A11	-	-
	VSS	GND Pin	-	A7	-	-
	VSS	GND Pin	-	C3	-	-
	VSS	GND Pin	-	A5	-	-
	VSS	GND Pin	80	A1	64	48
Clock	X0	Main clock (oscillation) input pin	38	L9	30	22
	X0A	Sub clock (oscillation) input pin	26	L3	19	15
	X1	Main clock (oscillation) I/O pin	39	L10	31	23
	X1A	Sub clock (oscillation) I/O pin	27	K3	20	16
	CROUT_0	Built-in high-speed CR-osc clock output port	60	C10	-	-
	CROUT_1		72	A6	57	42
Analog Power	AVCC	A/D converter and D/A converter analog power supply pin	50	H11	41	31
	AVRH	A/D converter analog reference voltage input pin	51	F11	42	32
Analog GND	AVSS	A/D converter and D/A converter GND pin	45	H10	37	28
	AVRL	A/D converter analog reference voltage input pin	52	G11	43	33
C pin	C	Power supply stabilization capacity pin	23	L2	17	13

**Note:**

- While this device contains a Test Access Port (TAP) based on the IEEE 1149.1-2001 JTAG standard, it is not fully compliant to all requirements of that standard. This device may contain a 32-bit device ID that is the same as the 32-bit device ID in other devices with different functionality. The TAP pins may also be configurable for purposes other than access to the TAP controller.

### 5. I/O Circuit Type

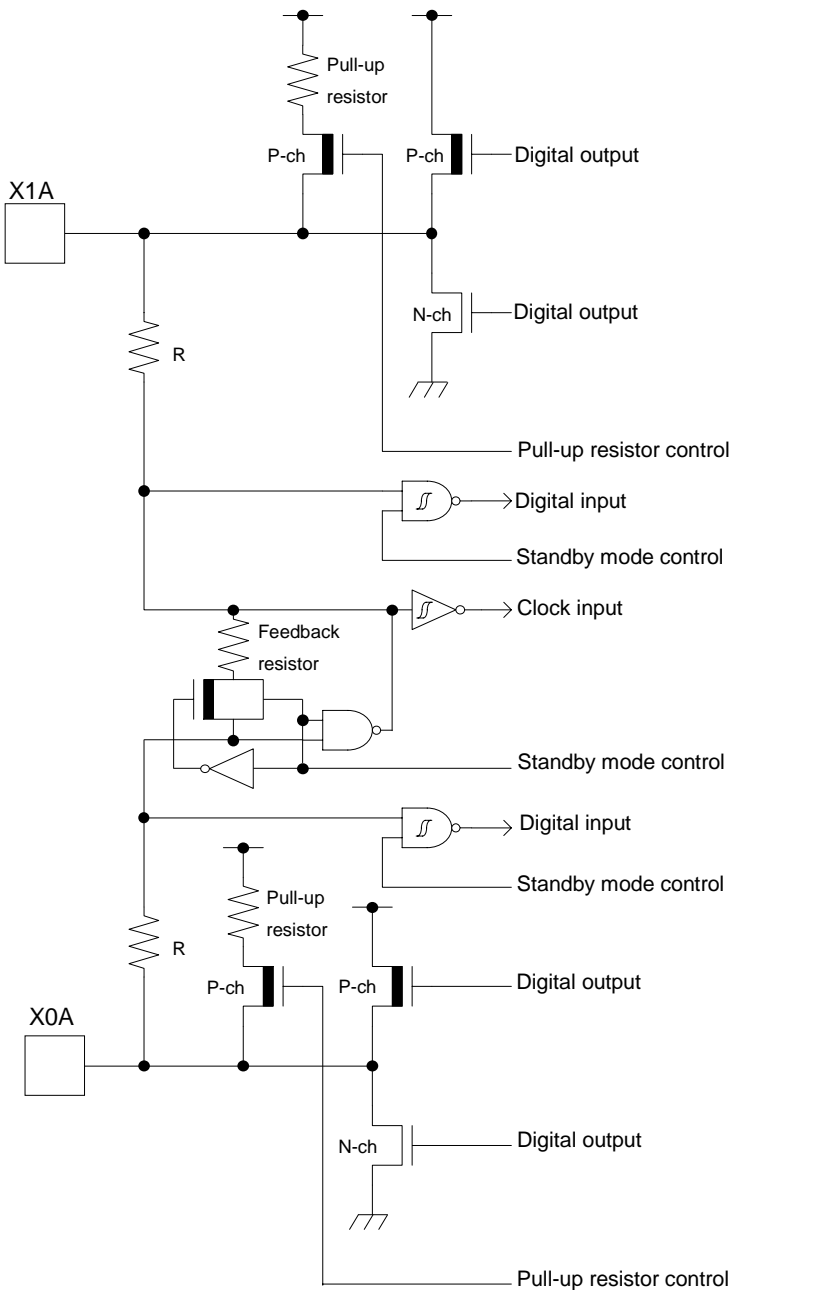
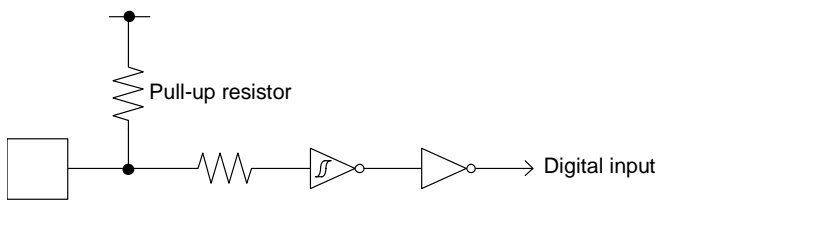
Type	Circuit	Remarks
A		<p>It is possible to select the main oscillation / GPIO function</p> <p>When the main oscillation is selected.</p> <ul style="list-style-type: none"> <li>• Oscillation feedback resistor : Approximately 1 MΩ</li> <li>• With Standby mode control</li> </ul> <p>When the GPIO is selected.</p> <ul style="list-style-type: none"> <li>• CMOS level output.</li> <li>• CMOS level hysteresis input</li> <li>• With pull-up resistor control</li> <li>• With standby mode control</li> <li>• Pull-up resistor : Approximately 50 kΩ</li> <li>• I<sub>OH</sub>= -4 mA, I<sub>OL</sub>= 4 mA</li> </ul>
B		<ul style="list-style-type: none"> <li>• CMOS level hysteresis input</li> <li>• Pull-up resistor : Approximately 50 kΩ</li> </ul>

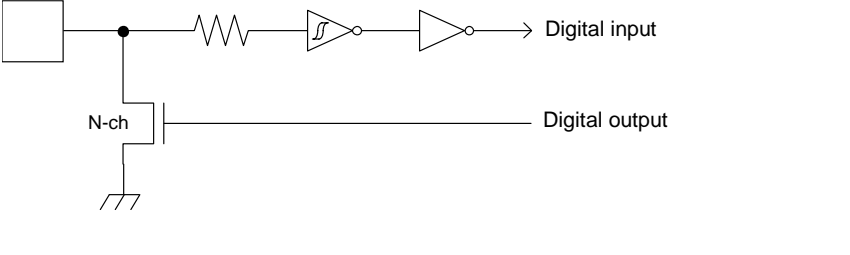
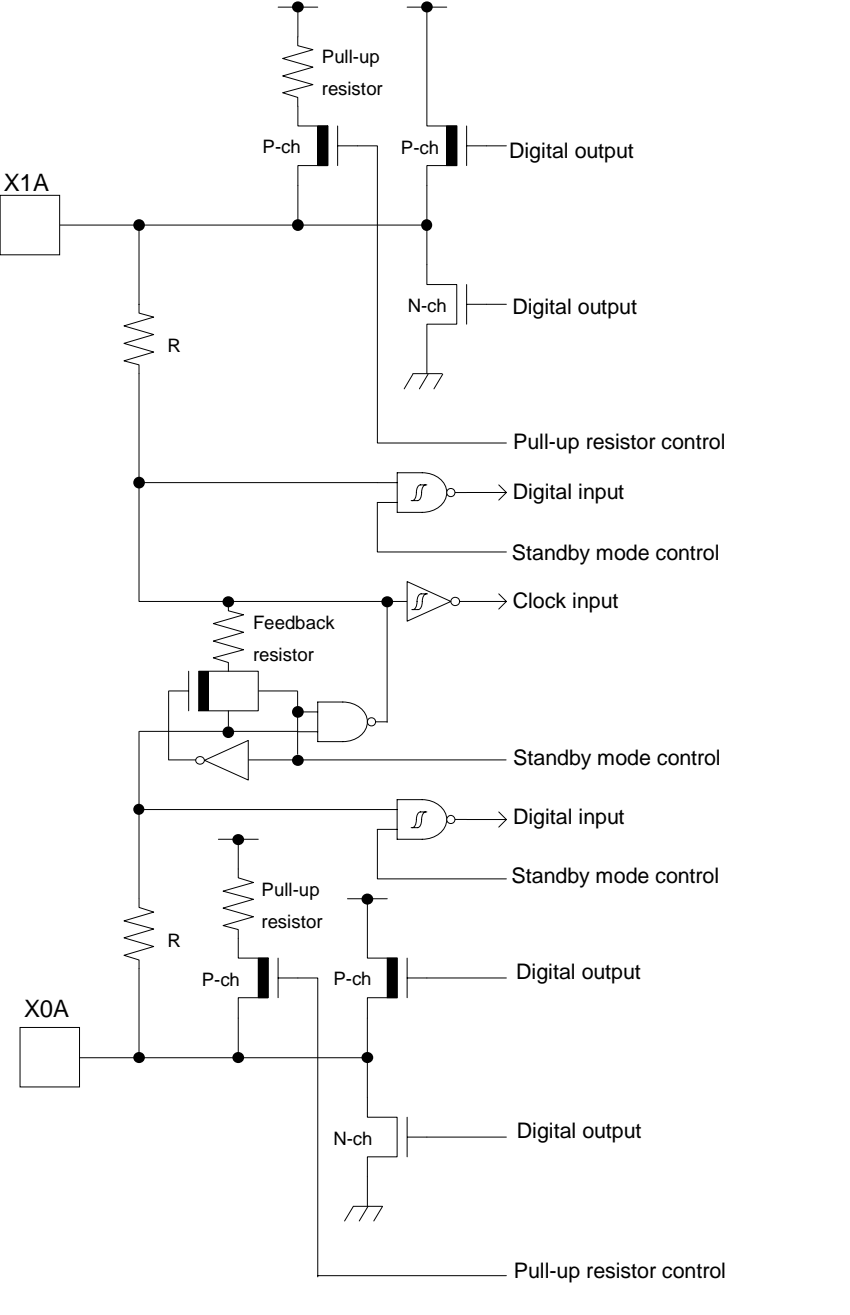
Type	Circuit	Remarks
C		<ul style="list-style-type: none"> <li>• Open drain output</li> <li>• CMOS level hysteresis input</li> </ul>
D		<p>It is possible to select the sub oscillation / GPIO function</p> <p>When the sub oscillation is selected.</p> <ul style="list-style-type: none"> <li>• Oscillation feedback resistor : Approximately 5 MΩ</li> <li>• With Standby mode control</li> </ul> <p>When the GPIO is selected.</p> <ul style="list-style-type: none"> <li>• CMOS level output.</li> <li>• CMOS level hysteresis input</li> <li>• With pull-up resistor control</li> <li>• With standby mode control</li> <li>• Pull-up resistor : Approximately 50 kΩ</li> <li>• I<sub>OH</sub>= -4 mA, I<sub>OL</sub>= 4 mA</li> </ul>

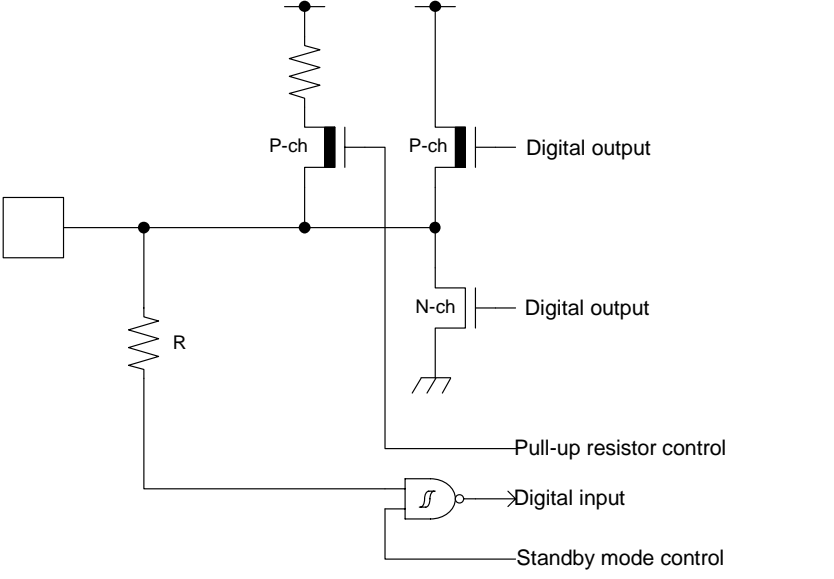
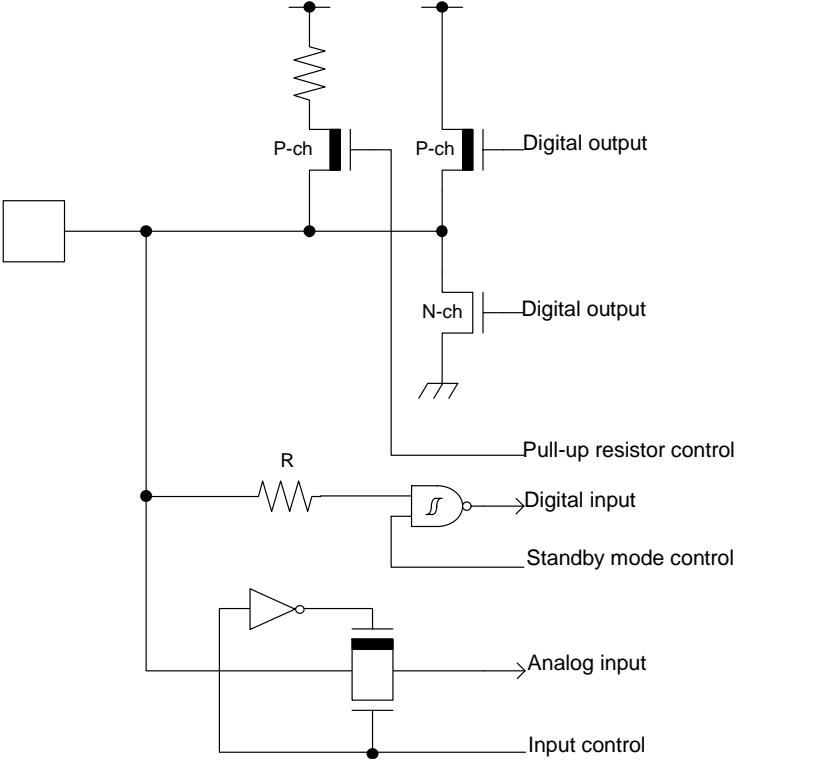
Type	Circuit	Remarks
E		<ul style="list-style-type: none"> <li>• CMOS level output</li> <li>• CMOS level hysteresis input</li> <li>• With pull-up resistor control</li> <li>• With standby mode control</li> <li>• Pull-up resistor : Approximately 50 kΩ</li> <li>• <math>I_{OH} = -4</math> mA, <math>I_{OL} = 4</math> mA</li> <li>• When this pin is used as an I<sup>2</sup>C pin, the digital output P-ch transistor is always off</li> <li>• +B input is available</li> </ul>
F		<ul style="list-style-type: none"> <li>• CMOS level output</li> <li>• CMOS level hysteresis input</li> <li>• With input control</li> <li>• Analog input</li> <li>• With pull-up resistor control</li> <li>• With standby mode control</li> <li>• Pull-up resistor : Approximately 50 kΩ</li> <li>• <math>I_{OH} = -4</math> mA, <math>I_{OL} = 4</math> mA</li> <li>• When this pin is used as an I<sup>2</sup>C pin, the digital output P-ch transistor is always off</li> <li>• +B input is available</li> </ul>

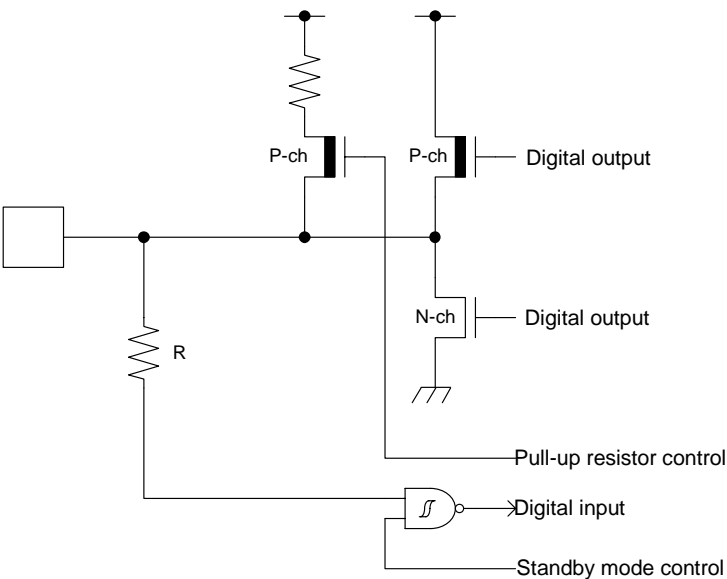
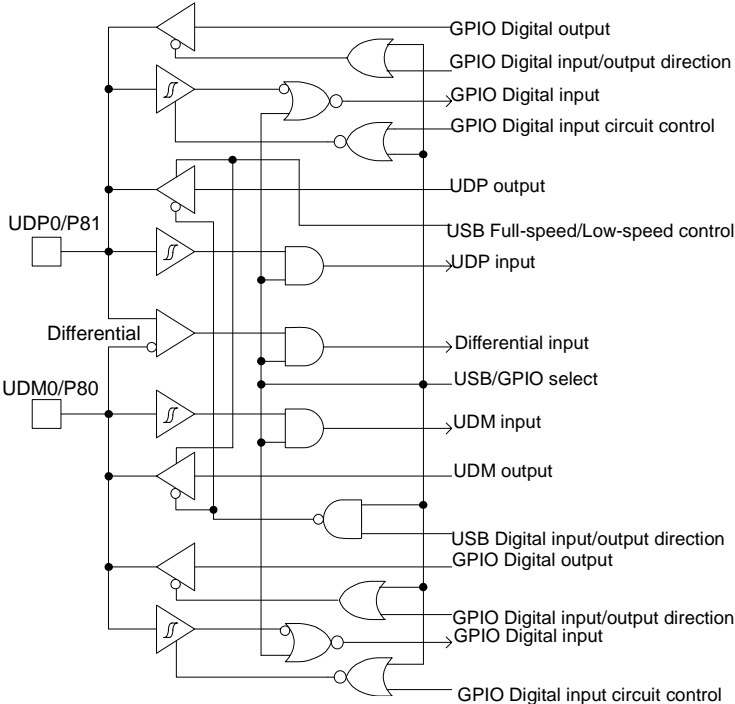
Type	Circuit	Remarks
G	 <p>The diagram shows a CMOS output stage. A pull-up resistor 'R' is connected to the output node. The output node is driven by a P-channel MOSFET (P-ch) and an N-channel MOSFET (N-ch). The P-ch MOSFET's gate is connected to a 'Pull-up resistor control' signal. The N-ch MOSFET's gate is connected to a 'Standby mode control' signal. The output node is also connected to a 'Digital input' through an inverter. Labels include: P-ch, Digital output, N-ch, Digital output, Pull-up resistor control, Digital input, Standby mode control, and R.</p>	<ul style="list-style-type: none"> <li>• CMOS level output</li> <li>• CMOS level hysteresis input</li> <li>• With pull-up resistor control</li> <li>• With standby mode control</li> <li>• Pull-up resistor : Approximately 50 kΩ</li> <li>• I<sub>OH</sub>= -12 mA, I<sub>OL</sub>= 12 mA</li> <li>• +B input is available</li> </ul>
H	 <p>The diagram shows a complex digital circuit with multiple inputs and outputs. It includes logic gates (AND, OR, NOT), inverters, and multiplexers. Labels include: UDP0/P81, Differential, UDM0/P80, GPIO Digital output, GPIO Digital input/output direction, GPIO Digital input, GPIO Digital input circuit control, UDP output, USB Full-speed/Low-speed control, UDP input, Differential input, USB/GPIO select, UDM input, UDM output, USB Digital input/output direction, GPIO Digital output, GPIO Digital input/output direction, GPIO Digital input, and GPIO Digital input circuit control.</p>	<p>It is possible to select the USB I/O / GPIO function.</p> <p>When the USB I/O is selected.</p> <ul style="list-style-type: none"> <li>• Full-speed, Low-speed control</li> </ul> <p>When the GPIO is selected.</p> <ul style="list-style-type: none"> <li>• CMOS level output</li> <li>• CMOS level hysteresis input</li> <li>• With standby mode control</li> </ul>

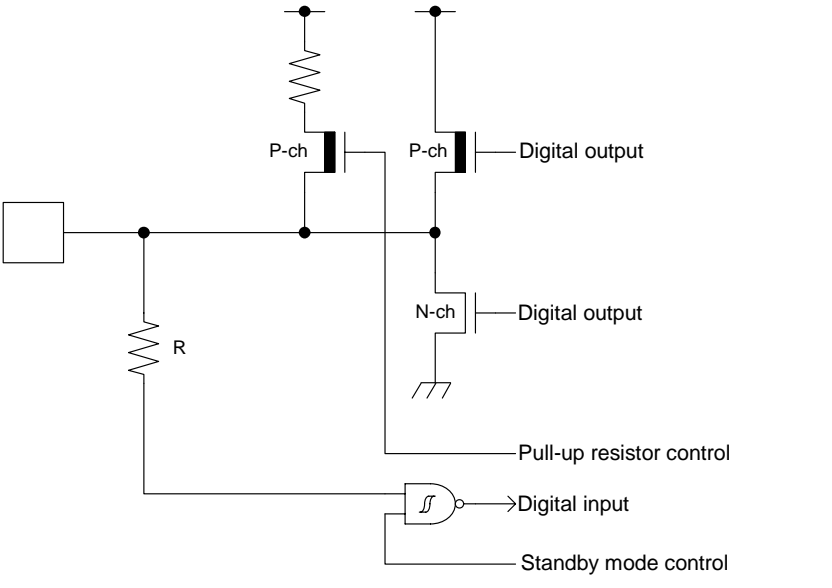
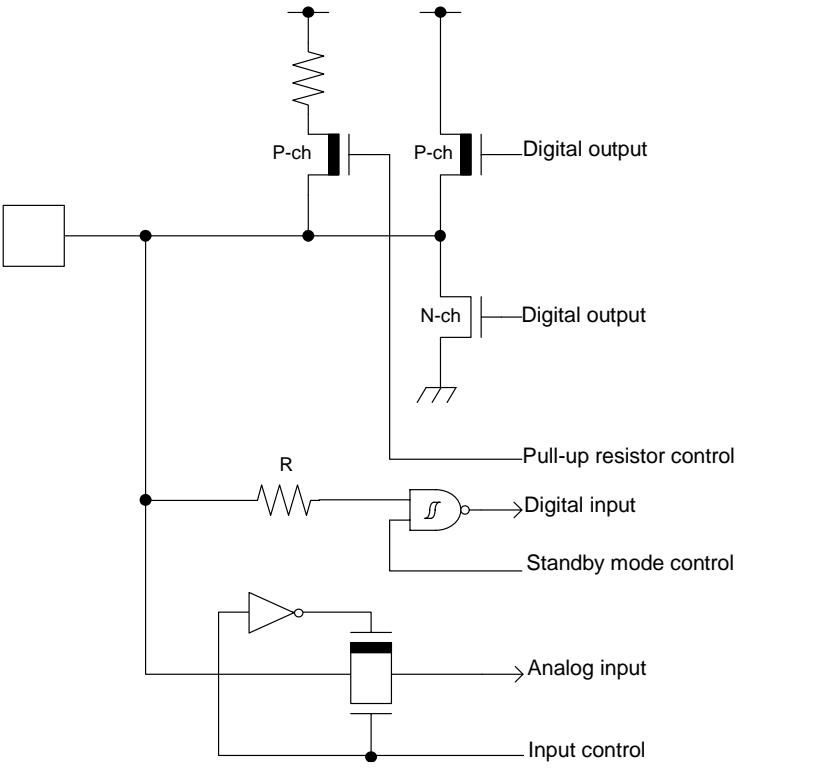
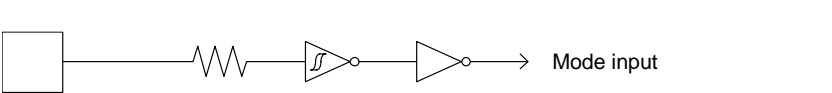
Type	Circuit	Remarks
I		<ul style="list-style-type: none"> <li>• CMOS level output</li> <li>• CMOS level hysteresis input</li> <li>• 5 V tolerant</li> <li>• With pull-up resistor control</li> <li>• With standby mode control</li> <li>• Pull-up resistor : Approximately 50 kΩ</li> <li>• <math>I_{OH} = -4 \text{ mA}</math>, <math>I_{OL} = 4 \text{ mA}</math></li> <li>• Available to control PZR registers.</li> <li>• When this pin is used as an I<sup>2</sup>C pin, the digital output P-ch transistor is always off</li> </ul>
J		<ul style="list-style-type: none"> <li>• CMOS level output</li> <li>• CMOS level hysteresis input</li> <li>• With input control</li> <li>• Analog input</li> <li>• 5 V tolerant</li> <li>• With pull-up resistor control</li> <li>• With standby mode control</li> <li>• Pull-up resistor : Approximately 50 kΩ</li> <li>• <math>I_{OH} = -4 \text{ mA}</math>, <math>I_{OL} = 4 \text{ mA}</math></li> <li>• Available to control PZR registers.</li> <li>• When this pin is used as an I<sup>2</sup>C pin, the digital output P-ch transistor is always off</li> </ul>
K		<p>CMOS level hysteresis input</p>

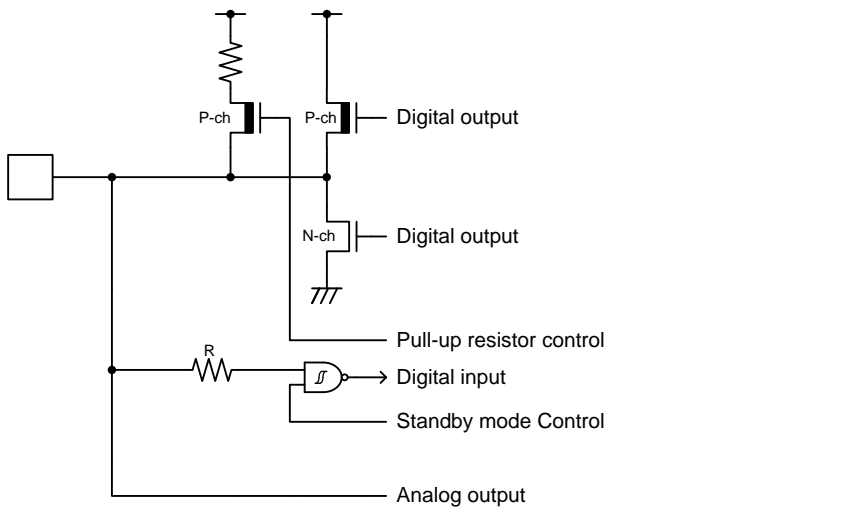
Type	Circuit	Remarks
L	 <p>The diagram shows a multiplexer circuit. A central node is connected to a pull-up resistor R. This node is controlled by a P-channel MOSFET (P-ch) and an N-channel MOSFET (N-ch). The P-ch MOSFET is also controlled by a pull-up resistor control signal. The N-ch MOSFET is controlled by a pull-up resistor control signal. The output of the multiplexer is connected to a digital output pin, a digital input pin (via an inverter), a standby mode control pin, and an analog output pin. The digital input pin is also controlled by a pull-up resistor control signal.</p>	<ul style="list-style-type: none"> <li>• CMOS level output</li> <li>• CMOS level hysteresis input</li> <li>• With input control</li> <li>• Analog output</li> <li>• With pull-up resistor control</li> <li>• With standby mode control</li> <li>• Pull-up resistor : Approximately 50 kΩ</li> <li>• <math>I_{OH} = -4 \text{ mA}</math>, <math>I_{OL} = 4 \text{ mA}</math></li> </ul>

## 6. Handling Precautions

Any semiconductor devices have inherently a certain rate of failure. The possibility of failure is greatly affected by the conditions in which they are used (circuit conditions, environmental conditions, etc.). This page describes precautions that must be observed to minimize the chance of failure and to obtain higher reliability from your Cypress semiconductor devices.

### 6.1 Precautions for Product Design

This section describes precautions when designing electronic equipment using semiconductor devices.

#### Absolute Maximum Ratings

Semiconductor devices can be permanently damaged by application of stress (voltage, current, temperature, etc.) in excess of certain established limits, called absolute maximum ratings. Do not exceed these ratings.

#### Recommended Operating Conditions

Recommended operating conditions are normal operating ranges for the semiconductor device. All the device's electrical characteristics are warranted when operated within these ranges.

Always use semiconductor devices within the recommended operating conditions. Operation outside these ranges may adversely affect reliability and could result in device failure.

No warranty is made with respect to uses, operating conditions, or combinations not represented on the data sheet. Users considering application outside the listed conditions are advised to contact their sales representative beforehand.

#### Processing and Protection of Pins

These precautions must be followed when handling the pins which connect semiconductor devices to power supply and input/output functions.

##### 1. Preventing Over-Voltage and Over-Current Conditions

Exposure to voltage or current levels in excess of maximum ratings at any pin is likely to cause deterioration within the device, and in extreme cases leads to permanent damage of the device. Try to prevent such overvoltage or over-current conditions at the design stage.

##### 2. Protection of Output Pins

Shorting of output pins to supply pins or other output pins, or connection to large capacitance can cause large current flows. Such conditions if present for extended periods of time can damage the device. Therefore, avoid this type of connection.

##### 3. Handling of Unused Input Pins

Unconnected input pins with very high impedance levels can adversely affect stability of operation. Such pins should be connected through an appropriate resistance to a power supply pin or ground pin.

#### Latch-up

Semiconductor devices are constructed by the formation of P-type and N-type areas on a substrate. When subjected to abnormally high voltages, internal parasitic PNP junctions (called thyristor structures) may be formed, causing large current levels in excess of several hundred mA to flow continuously at the power supply pin. This condition is called latch-up.

**CAUTION:** The occurrence of latch-up not only causes loss of reliability in the semiconductor device, but can cause injury or damage from high heat, smoke or flame. To prevent this from happening, do the following:

1. Be sure that voltages applied to pins do not exceed the absolute maximum ratings. This should include attention to abnormal noise, surge levels, etc.
2. Be sure that abnormal current flows do not occur during the power-on sequence.

#### Observance of Safety Regulations and Standards

Most countries in the world have established standards and regulations regarding safety, protection from electromagnetic interference, etc. Customers are requested to observe applicable regulations and standards in the design of products.

#### Fail-Safe Design

Any semiconductor devices have inherently a certain rate of failure. You must protect against injury, damage or loss from such failures by incorporating safety design measures into your facility and equipment such as redundancy, fire protection, and prevention of over-current levels and other abnormal operating conditions.

## Precautions Related to Usage of Devices

Cypress semiconductor devices are intended for use in standard applications (computers, office automation and other office equipment, industrial, communications, and measurement equipment, personal or household devices, etc.).

CAUTION: Customers considering the use of our products in special applications where failure or abnormal operation may directly affect human lives or cause physical injury or property damage, or where extremely high levels of reliability are demanded (such as aerospace systems, atomic energy controls, sea floor repeaters, vehicle operating controls, medical devices for life support, etc.) are requested to consult with sales representatives before such use. The company will not be responsible for damages arising from such use without prior approval.

## 6.2 Precautions for Package Mounting

Package mounting may be either lead insertion type or surface mount type. In either case, for heat resistance during soldering, you should only mount under Cypress' recommended conditions. For detailed information about mount conditions, contact your sales representative.

### Lead Insertion Type

Mounting of lead insertion type packages onto printed circuit boards may be done by two methods: direct soldering on the board, or mounting by using a socket.

Direct mounting onto boards normally involves processes for inserting leads into through-holes on the board and using the flow soldering (wave soldering) method of applying liquid solder. In this case, the soldering process usually causes leads to be subjected to thermal stress in excess of the absolute ratings for storage temperature. Mounting processes should conform to Cypress recommended mounting conditions.

If socket mounting is used, differences in surface treatment of the socket contacts and IC lead surfaces can lead to contact deterioration after long periods. For this reason it is recommended that the surface treatment of socket contacts and IC leads be verified before mounting.

### Surface Mount Type

Surface mount packaging has longer and thinner leads than lead-insertion packaging, and therefore leads are more easily deformed or bent. The use of packages with higher pin counts and narrower pin pitch results in increased susceptibility to open connections caused by deformed pins, or shorting due to solder bridges.

You must use appropriate mounting techniques. Cypress recommends the solder reflow method, and has established a ranking of mounting conditions for each product. Users are advised to mount packages in accordance with Cypress ranking of recommended conditions.

### Lead-Free Packaging

CAUTION: When ball grid array (BGA) packages with Sn-Ag-Cu balls are mounted using Sn-Pb eutectic soldering, junction strength may be reduced under some conditions of use.

## Storage of Semiconductor Devices

Because plastic chip packages are formed from plastic resins, exposure to natural environmental conditions will cause absorption of moisture. During mounting, the application of heat to a package that has absorbed moisture can cause surfaces to peel, reducing moisture resistance and causing packages to crack. To prevent, do the following:

1. Avoid exposure to rapid temperature changes, which cause moisture to condense inside the product. Store products in locations where temperature changes are slight.
2. Use dry boxes for product storage. Products should be stored below 70% relative humidity, and at temperatures between 5°C and 30°C.  
When you open Dry Package that recommends humidity 40% to 70% relative humidity.
3. When necessary, Cypress packages semiconductor devices in highly moisture-resistant aluminum laminate bags, with a silica gel desiccant. Devices should be sealed in their aluminum laminate bags for storage.
4. Avoid storing packages where they are exposed to corrosive gases or high levels of dust.

## Baking

Packages that have absorbed moisture may be de-moisturized by baking (heat drying). Follow the Cypress recommended conditions for baking.

Condition: 125°C/24 h

### Static Electricity

Because semiconductor devices are particularly susceptible to damage by static electricity, you must take the following precautions:

1. Maintain relative humidity in the working environment between 40% and 70%. Use of an apparatus for ion generation may be needed to remove electricity.
2. Electrically ground all conveyors, solder vessels, soldering irons and peripheral equipment.
3. Eliminate static body electricity by the use of rings or bracelets connected to ground through high resistance (on the level of 1 MΩ).  
Wearing of conductive clothing and shoes, use of conductive floor mats and other measures to minimize shock loads is recommended.
4. Ground all fixtures and instruments, or protect with anti-static measures.
5. Avoid the use of styrofoam or other highly static-prone materials for storage of completed board assemblies.

### 6.3 Precautions for Use Environment

Reliability of semiconductor devices depends on ambient temperature and other conditions as described above.

For reliable performance, do the following:

1. Humidity  
Prolonged use in high humidity can lead to leakage in devices as well as printed circuit boards. If high humidity levels are anticipated, consider anti-humidity processing.
2. Discharge of Static Electricity  
When high-voltage charges exist close to semiconductor devices, discharges can cause abnormal operation. In such cases, use anti-static measures or processing to prevent discharges.
3. Corrosive Gases, Dust, or Oil  
Exposure to corrosive gases or contact with dust or oil may lead to chemical reactions that will adversely affect the device. If you use devices in such conditions, consider ways to prevent such exposure or to protect the devices.
4. Radiation, Including Cosmic Radiation  
Most devices are not designed for environments involving exposure to radiation or cosmic radiation. Users should provide shielding as appropriate.
5. Smoke, Flame  
**CAUTION:** Plastic molded devices are flammable, and therefore should not be used near combustible substances. If devices begin to smoke or burn, there is danger of the release of toxic gases.

Customers considering the use of Cypress products in other special environmental conditions should consult with sales representatives.

## 7. Handling Devices

### Power supply pins

In products with multiple VCC and VSS pins, respective pins at the same potential are interconnected within the device in order to prevent malfunctions such as latch-up. However, all of these pins should be connected externally to the power supply or ground lines in order to reduce electromagnetic emission levels, to prevent abnormal operation of strobe signals caused by the rise in the ground level, and to conform to the total output current rating.

Moreover, connect the current supply source with each Power supply pin and GND pin of this device at low impedance. It is also advisable that a ceramic capacitor of approximately 0.1  $\mu\text{F}$  be connected as a bypass capacitor between each Power supply pin and GND pin, between AVCC pin and AVSS pin, between AVRH pin and AVRL pin near this device.

### Stabilizing power supply voltage

A malfunction may occur when the power supply voltage fluctuates rapidly even though the fluctuation is within the recommended operating conditions of the VCC power supply voltage. As a rule, with voltage stabilization, suppress the voltage fluctuation so that the fluctuation in VCC ripple (peak-to-peak value) at the commercial frequency (50 Hz/60 Hz) does not exceed 10% of the VCC value in the recommended operating conditions, and the transient fluctuation rate does not exceed 0.1 V/ $\mu\text{s}$  when there is a momentary fluctuation on switching the power supply.

### Crystal oscillator circuit

Noise near the X0/X1 and X0A/X1A pins may cause the device to malfunction. Design the printed circuit board so that X0/X1, X0A/X1A pins, the crystal oscillator, and the bypass capacitor to ground are located as close to the device as possible.

It is strongly recommended that the PC board artwork be designed such that the X0/X1 and X0A/X1A pins are surrounded by ground plane as this is expected to produce stable operation.

Evaluate oscillation of your using crystal oscillator by your mount board.

### Sub crystal oscillator

This series sub oscillator circuit is low gain to keep the low current consumption. The crystal oscillator to fill the following conditions is recommended for sub crystal oscillator to stabilize the oscillation.

- Surface mount type
  - Size: More than 3.2 mm x 1.5 mm
  - Load capacitance: Approximately 6 pF to 7 pF
- Lead type
  - Load capacitance: Approximately 6 pF to 7 pF

### Using an external clock

When using an external clock as an input of the main clock, set X0/X1 to the external clock input, and input the clock to X0. X1(PE3) can be used as a general-purpose I/O port.

Similarly, when using an external clock as an input of the sub clock, set X0A/X1A to the external clock input, and input the clock to X0A. X1A (P47) can be used as a general-purpose I/O port.

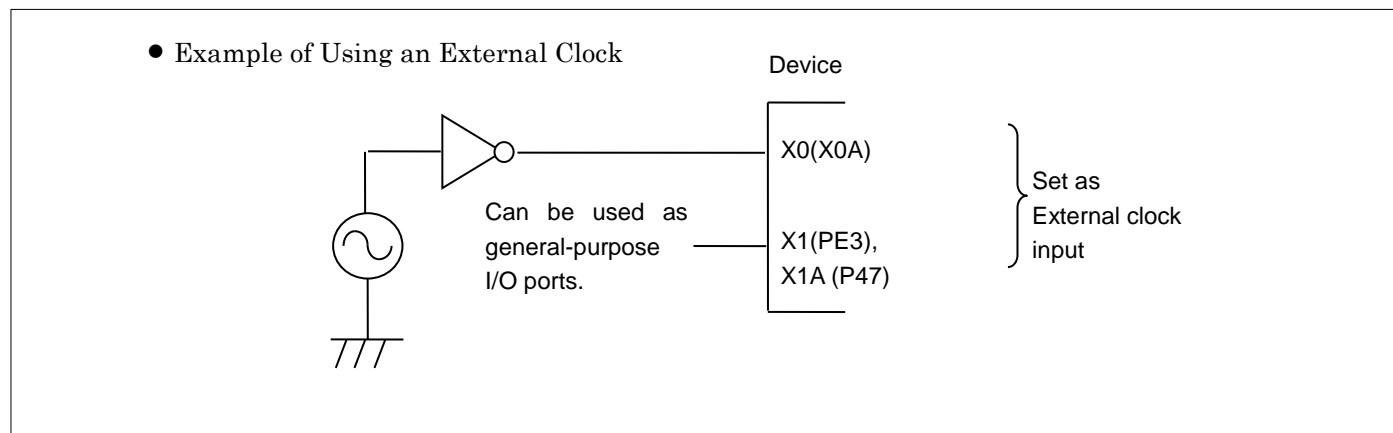

**Handling when using Multi-function serial pin as I<sup>2</sup>C pin**

If it is using the multi-function serial pin as I<sup>2</sup>C pins, P-ch transistor of digital output is always disabled. However, I<sup>2</sup>C pins need to keep the electrical characteristic like other pins and not to connect to the external I<sup>2</sup>C bus system with power OFF.

**C Pin**

This series contains the regulator. Be sure to connect a smoothing capacitor (C<sub>s</sub>) for the regulator between the C pin and the GND pin. Please use a ceramic capacitor or a capacitor of equivalent frequency characteristics as a smoothing capacitor. However, some laminated ceramic capacitors have the characteristics of capacitance variation due to thermal fluctuation (F characteristics and Y5V characteristics). Please select the capacitor that meets the specifications in the operating conditions to use by evaluating the temperature characteristics of a capacitor. A smoothing capacitor of about 4.7 μF would be recommended for this series.

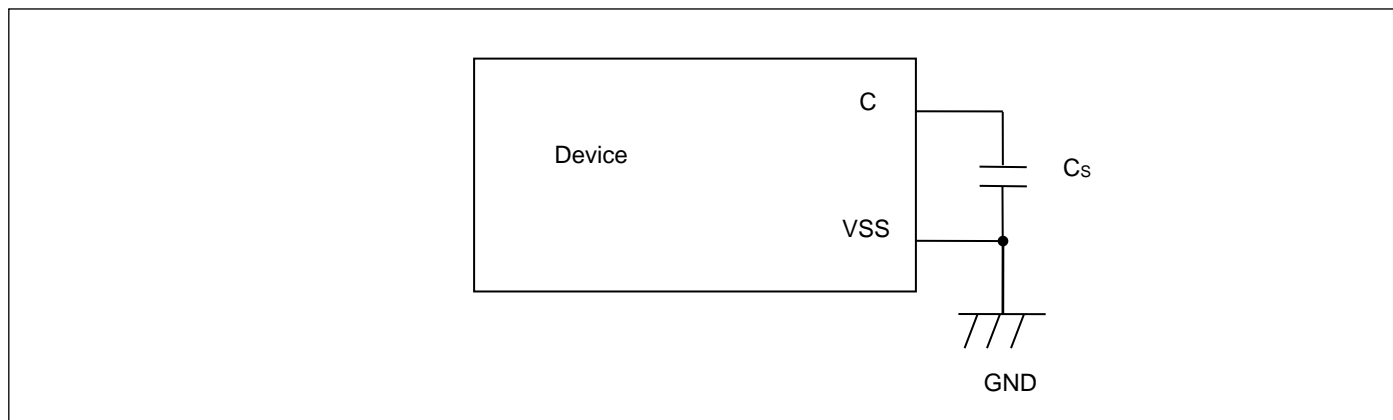

**Mode pins (MD0)**

Connect the MD pin (MD0) directly to VCC or VSS pins. Design the printed circuit board such that the pull-up/down resistance stays low, as well as the distance between the mode pins and VCC pins or VSS pins is as short as possible and the connection impedance is low, when the pins are pulled-up/down such as for switching the pin level and rewriting the Flash memory data. It is because of preventing the device erroneously switching to test mode due to noise.

**Notes on power-on**

Turn power on/off in the following order or at the same time.  
 If not using the A/D converter and D/A converter, connect AVCC = VCC and AVSS = VSS.

- Turning on : VCC → USBVCC
- VCC → AVCC → AVRH
- Turning off : AVRH → AVCC → VCC
- USBVCC → VCC

**Serial Communication**

There is a possibility to receive wrong data due to the noise or other causes on the serial communication. Therefore, design a printed circuit board so as to avoid noise. Consider the case of receiving wrong data due to noise, perform error detection such as by applying a checksum of data at the end. If an error is detected, retransmit the data.

**Differences in features among the products with different memory sizes and between Flash memory products and MASK products**

The electric characteristics including power consumption, ESD, latch-up, noise characteristics, and oscillation characteristics among the products with different memory sizes and between Flash memory products and MASK products are different because chip layout and memory structures are different. If you are switching to use a different product of the same series, please make sure to evaluate the electric characteristics.

**Pull-Up function of 5 V tolerant I/O**

Please do not input the signal more than VCC voltage at the time of Pull-Up function use of 5 V tolerant I/O.

### 8. Block Diagram

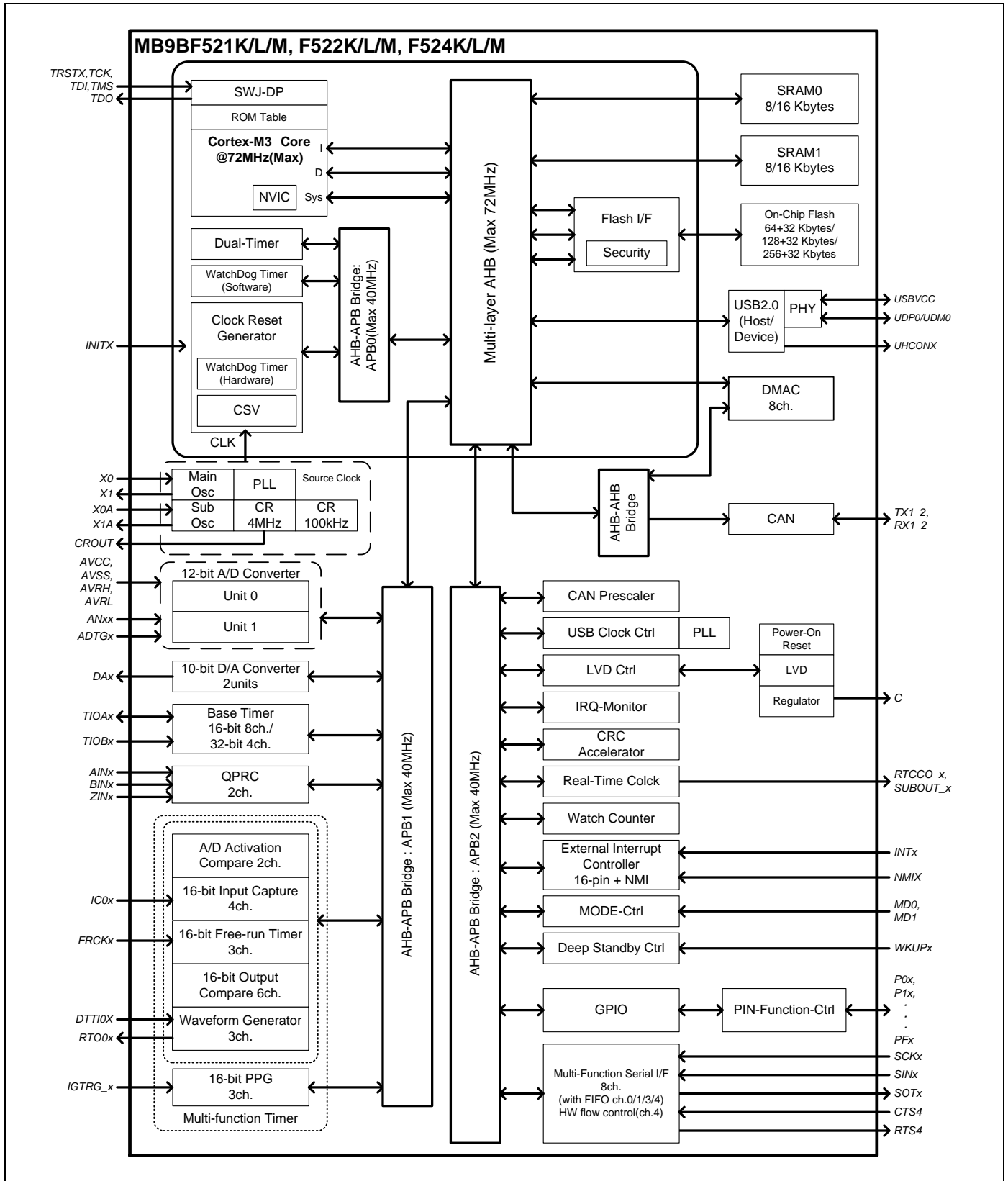

### 9. Memory Size

See "Memory size" in "Product Lineup" to confirm the memory size.

### 10. Memory Map

#### Memory Map (1)

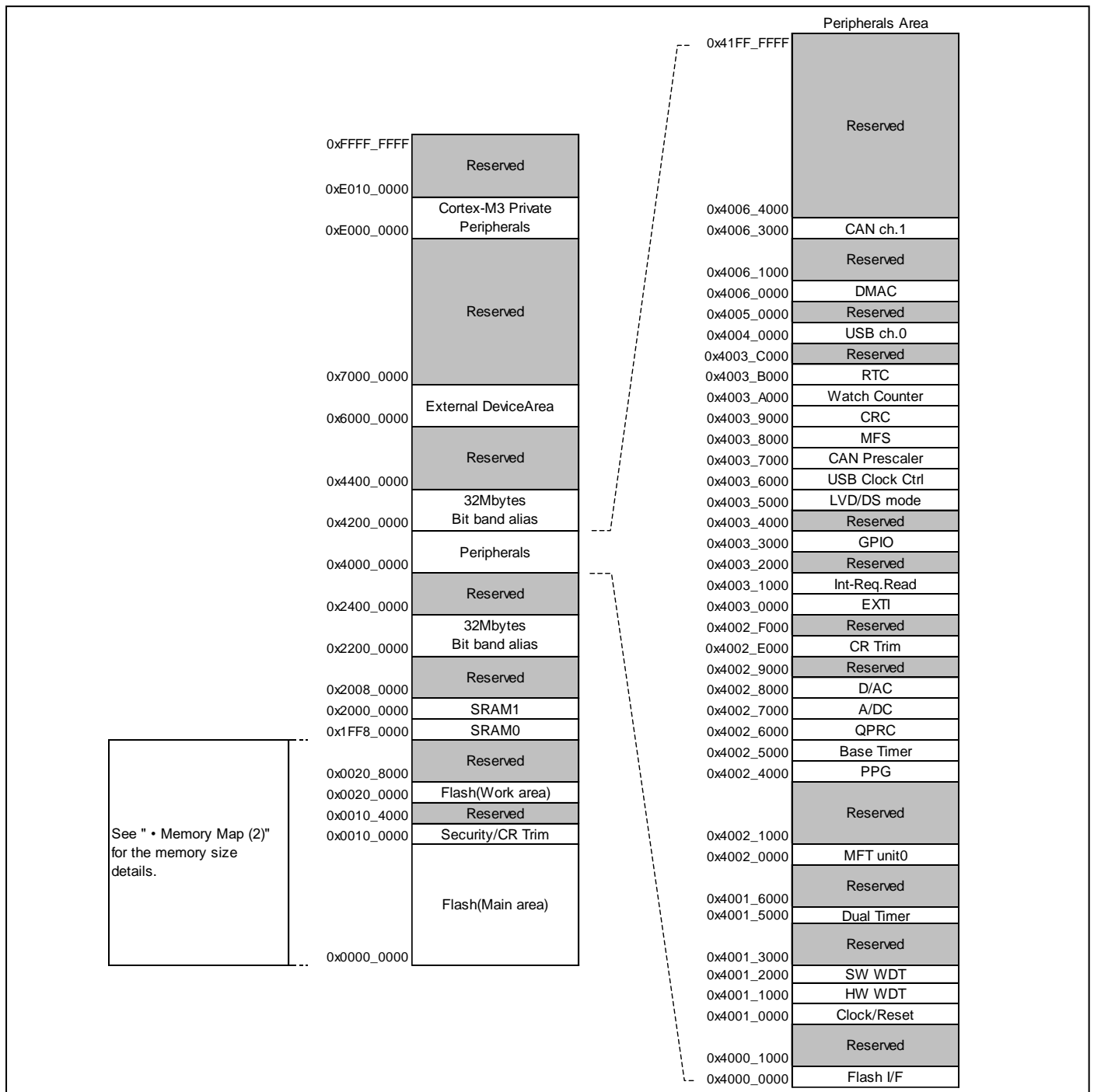

See " • Memory Map (2)" for the memory size details.

Memory Map (2)

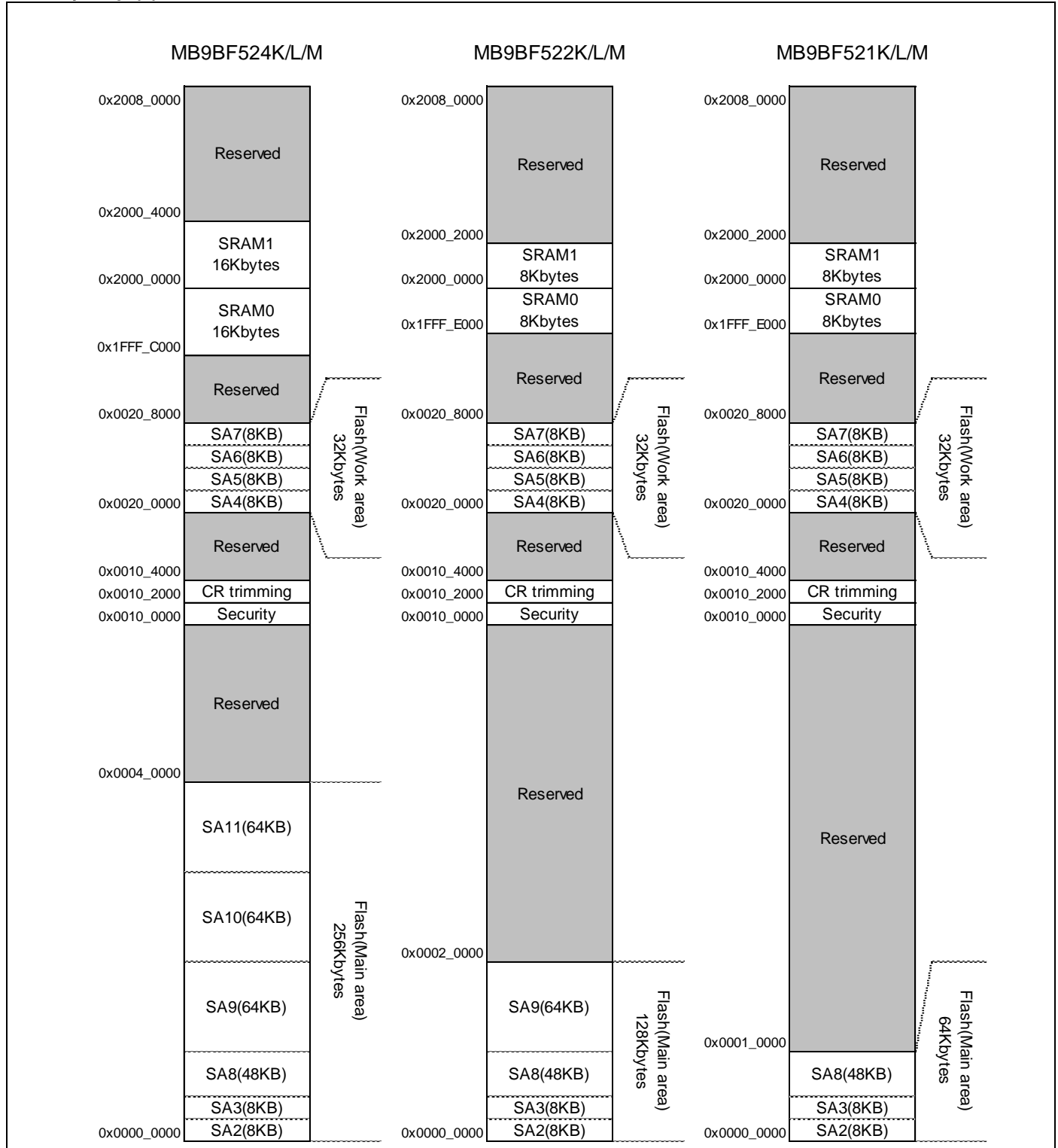

Refer to the programming manual for the detail of Flash main area.

■ CY9AB40N/A40N/340N/140N/150R, CY9B520M/320M/120M Series Flash Programming Manual

**Peripheral Address Map**

Start address	End address	Bus	Peripherals
0x4000_0000	0x4000_0FFF	AHB	Flash Memory I/F register
0x4000_1000	0x4000_FFFF		Reserved
0x4001_0000	0x4001_0FFF	APB0	Clock/Reset Control
0x4001_1000	0x4001_1FFF		Hardware Watchdog timer
0x4001_2000	0x4001_2FFF		Software Watchdog timer
0x4001_3000	0x4001_4FFF		Reserved
0x4001_5000	0x4001_5FFF		Dual-Timer
0x4001_6000	0x4001_FFFF		Reserved
0x4002_0000	0x4002_0FFF		APB1
0x4002_1000	0x4002_3FFF	Reserved	
0x4002_4000	0x4002_4FFF	PPG	
0x4002_5000	0x4002_5FFF	Base Timer	
0x4002_6000	0x4002_6FFF	Quadrature Position/Revolution Counter (QPRC)	
0x4002_7000	0x4002_7FFF	A/D Converter	
0x4002_8000	0x4002_8FFF	D/A Converter	
0x4002_9000	0x4002_DFFF	Reserved	
0x4002_E000	0x4002_EFFF	Built-in CR trimming	
0x4002_F000	0x4002_FFFF	Reserved	
0x4003_0000	0x4003_0FFF	APB2	
0x4003_1000	0x4003_1FFF		Interrupt Source Check Resister
0x4003_2000	0x4003_2FFF		Reserved
0x4003_3000	0x4003_3FFF		GPIO
0x4003_4000	0x4003_4FFF		Reserved
0x4003_5000	0x4003_57FF		Low-Voltage Detector
0x4003_5800	0x4003_5FFF		Deep standby mode Controller
0x4003_6000	0x4003_6FFF		USB clock generator
0x4003_7000	0x4003_7FFF		CAN prescaler
0x4003_8000	0x4003_8FFF		Multi-function serial Interface
0x4003_9000	0x4003_9FFF		CRC
0x4003_A000	0x4003_AFFF		Watch Counter
0x4003_B000	0x4003_BFFF		Real-time clock
0x4003_C000	0x4003_FFFF		Reserved
0x4004_0000	0x4004_FFFF		AHB
0x4005_0000	0x4005_FFFF	Reserved	
0x4006_0000	0x4006_0FFF	DMAC register	
0x4006_1000	0x4006_2FFF	Reserved	
0x4006_3000	0x4006_3FFF	CAN ch.1	
0x4006_4000	0x41FF_FFFF	Reserved	

## 11. Pin Status in Each CPU State

The terms used for pin status have the following meanings.

■ **INITX=0**

This is the period when the INITX pin is the "L" level.

■ **INITX=1**

This is the period when the INITX pin is the "H" level.

■ **SPL=0**

This is the status that the standby pin level setting bit (SPL) in the standby mode control register (STB\_CTL) is set to "0".

■ **SPL=1**

This is the status that the standby pin level setting bit (SPL) in the standby mode control register (STB\_CTL) is set to "1".

■ **Input enabled**

Indicates that the input function can be used.

■ **Internal input fixed at "0"**

This is the status that the input function cannot be used. Internal input is fixed at "L".

■ **Hi-Z**

Indicates that the pin drive transistor is disabled and the pin is put in the Hi-Z state.

■ **Setting disabled**

Indicates that the setting is disabled.

■ **Maintain previous state**

Maintains the state that was immediately prior to entering the current mode.

If a built-in peripheral function is operating, the output follows the peripheral function.

If the pin is being used as a port, that output is maintained.

■ **Analog input is enabled**

Indicates that the analog input is enabled.

■ **Trace output**

Indicates that the trace function can be used.

■ **GPIO selected**

In Deep standby mode, pins switch to the general-purpose I/O port.

List of Pin Status

Pin status type	Function group	Power-on reset or low-voltage detection state	INITX input state	Device internal reset state	Run mode or SLEEP mode state	Timer mode, RTC mode, or STOP mode state		Deep standby RTC mode or Deep standby STOP mode state		Return from Deep standby mode state
		Power supply unstable	Power supply stable		Power supply stable	Power supply stable		Power supply stable		Power supply stable
		-	INITX = 0	INITX = 1	INITX = 1	INITX = 1		INITX = 1		INITX = 1
		-	-	-	-	SPL = 0	SPL = 1	SPL = 0	SPL = 1	-
A	GPIO selected	Setting disabled	Setting disabled	Setting disabled	Maintain previous state	Maintain previous state	Hi-Z / Internal input fixed at "0"	GPIO selected Internal input fixed at "0"	Hi-Z / Internal input fixed at "0"	GPIO selected
	Main crystal oscillator input pin/ External main clock input selected	Input enabled	Input enabled	Input enabled	Input enabled	Input enabled	Input enabled	Input enabled	Input enabled	Input enabled
B	GPIO selected	Setting disabled	Setting disabled	Setting disabled	Maintain previous state	Maintain previous state	Hi-Z / Internal input fixed at "0"	GPIO selected Internal input fixed at "0"	Hi-Z / Internal input fixed at "0"	GPIO selected
	External main clock input selected	Setting disabled	Setting disabled	Setting disabled	Maintain previous state	Maintain previous state	Hi-Z / Internal input fixed at "0"	Maintain previous state	Hi-Z / Internal input fixed at "0"	Maintain previous state
	Main crystal oscillator output pin	Hi-Z / Internal input fixed at "0"/ or Input enabled	Hi-Z / Internal input fixed at "0"	Hi-Z / Internal input fixed at "0"	Maintain previous state/When oscillation stops*1, Hi-Z / Internal input fixed at "0"	Maintain previous state/When oscillation stops*1, Hi-Z / Internal input fixed at "0"	Maintain previous state/When oscillation stops*1, Hi-Z / Internal input fixed at "0"	Maintain previous state/When oscillation stops*1, Hi-Z / Internal input fixed at "0"	Maintain previous state/When oscillation stops*1, Hi-Z / Internal input fixed at "0"	Maintain previous state/When oscillation stops*1, Hi-Z / Internal input fixed at "0"
C	INITX input pin	Pull-up / Input enabled	Pull-up / Input enabled	Pull-up / Input enabled	Pull-up / Input enabled	Pull-up / Input enabled	Pull-up / Input enabled	Pull-up / Input enabled	Pull-up / Input enabled	Pull-up / Input enabled
D	Mode input pin	Input enabled	Input enabled	Input enabled	Input enabled	Input enabled	Input enabled	Input enabled	Input enabled	Input enabled

Pin status type	Function group	Power-on reset or low-voltage detection state	INITX input state	Device internal reset state	Run mode or SLEEP mode state	Timer mode, RTC mode, or STOP mode state		Deep standby RTC mode or Deep standby STOP mode state		Return from Deep standby mode state
		Power supply unstable	Power supply stable		Power supply stable	Power supply stable		Power supply stable		Power supply stable
		-	INITX = 0	INITX = 1	INITX = 1	INITX = 1		INITX = 1		INITX = 1
		-	-	-	-	SPL = 0	SPL = 1	SPL = 0	SPL = 1	-
E	Mode input pin	Input enabled	Input enabled	Input enabled	Input enabled	Input enabled	Input enabled	Input enabled	Input enabled	Input enabled
	GPIO selected	Setting disabled	Setting disabled	Setting disabled	Maintain previous state	Maintain previous state	Hi-Z / Input enabled	GPIO selected	Hi-Z / Input enabled	GPIO selected
F	GPIO selected	Setting disabled	Setting disabled	Setting disabled	Maintain previous state	Maintain previous state	Hi-Z / Internal input fixed at "0"	GPIO selected Internal input fixed at "0"	Hi-Z / Internal input fixed at "0"	GPIO selected
	Sub crystal oscillator input pin / External sub clock input selected	Input enabled	Input enabled	Input enabled	Input enabled	Input enabled	Input enabled	Input enabled	Input enabled	Input enabled
G	GPIO selected	Setting disabled	Setting disabled	Setting disabled	Maintain previous state	Maintain previous state	Hi-Z / Internal input fixed at "0"	GPIO selected Internal input fixed at "0"	Hi-Z / Internal input fixed at "0"	GPIO selected
	External sub clock input selected	Setting disabled	Setting disabled	Setting disabled	Maintain previous state	Maintain previous state	Hi-Z / Internal input fixed at "0"	Maintain previous state	Hi-Z / Internal input fixed at "0"	Maintain previous state
	Sub crystal oscillator output pin	Hi-Z / Internal input fixed at "0" / or Input enable	Hi-Z / Internal input fixed at "0"	Hi-Z / Internal input fixed at "0"	Maintain previous state	Maintain previous state/When oscillation stops*2, Hi-Z / Internal input fixed at "0"	Maintain previous state/When oscillation stops*2, Hi-Z / Internal input fixed at "0"	Maintain previous state/When oscillation stops*2, Hi-Z / Internal input fixed at "0"	Maintain previous state/When oscillation stops*2, Hi-Z / Internal input fixed at "0"	Maintain previous state/When oscillation stops*2, Hi-Z / Internal input fixed at "0"

Pin status type	Function group	Power-on reset or low-voltage detection state	INITX input state	Device internal reset state	Run mode or SLEEP mode state	Timer mode, RTC mode, or STOP mode state		Deep standby RTC mode or Deep standby STOP mode state		Return from Deep standby mode state
		Power supply unstable	Power supply stable		Power supply stable	Power supply stable		Power supply stable		Power supply stable
		-	INITX = 0	INITX = 1	INITX = 1	INITX = 1		INITX = 1		INITX = 1
		-	-	-	-	SPL = 0	SPL = 1	SPL = 0	SPL = 1	-
H	External interrupt enabled selected	Setting disabled	Setting disabled	Setting disabled	Maintain previous state	Maintain previous state	Maintain previous state	GPIO selected Internal input fixed at "0"	Hi-Z / Internal input fixed at "0"	GPIO selected
	GPIO selected	Hi-Z	Hi-Z / Input enabled	Hi-Z / Input enabled			Hi-Z / Internal input fixed at "0"			
	USB I/O pin	Setting disabled	Setting disabled	Setting disabled		Hi-Z at transmission/ Input enabled/ Internal input fixed at "0" at reception	Hi-Z at transmission/ Input enabled/ Internal input fixed at "0" at reception	Hi-Z / Input enabled	Hi-Z / Input enabled	
I	Analog input selected	Hi-Z	Hi-Z / Internal input fixed at "0" / Analog input enabled	Hi-Z / Internal input fixed at "0" / Analog input enabled	Hi-Z / Internal input fixed at "0" / Analog input enabled	Hi-Z / Internal input fixed at "0" / Analog input enabled	Hi-Z / Internal input fixed at "0" / Analog input disabled	Hi-Z / Internal input fixed at "0" / Analog input disabled	Hi-Z / Internal input fixed at "0" / Analog input disabled	Hi-Z / Internal input fixed at "0" / Analog input disabled
	NMIX selected	Setting disabled	Setting disabled	Setting disabled	Maintain previous state	Maintain previous state	Maintain previous state	WKUP input enabled	Hi-Z / WKUP input enabled	GPIO selected
	Resource other than above selected	Hi-Z	Hi-Z / Input enabled	Hi-Z / Input enabled			Hi-Z / Internal input fixed at "0"			
GPIO selected	Maintain previous state									
J	JTAG selected	Hi-Z	Pull-up / Input enabled	Pull-up / Input enabled	Maintain previous state	Maintain previous state	Maintain previous state	Maintain previous state	Maintain previous state	Maintain previous state
	GPIO selected	Setting disabled	Setting disabled	Setting disabled			Hi-Z / Internal input fixed at "0"	GPIO selected Internal input fixed at "0"	Hi-Z / Internal input fixed at "0"	GPIO selected

Pin status type	Function group	Power-on reset or low-voltage detection state	INITX input state	Device internal reset state	Run mode or SLEEP mode state	Timer mode, RTC mode, or STOP mode state		Deep standby RTC mode or Deep standby STOP mode state		Return from Deep standby mode state
		Power supply unstable	Power supply stable		Power supply stable	Power supply stable		Power supply stable		Power supply stable
		-	INITX = 0	INITX = 1	INITX = 1	INITX = 1		INITX = 1		INITX = 1
		-	-	-	-	SPL = 0	SPL = 1	SPL = 0	SPL = 1	-
K	Resource selected	Hi-Z	Hi-Z / Input enabled	Hi-Z / Input enabled	Maintain previous state	Maintain previous state	Hi-Z / Internal input fixed at "0"	GPIO selected Internal input fixed at "0"	Hi-Z / Internal input fixed at "0"	GPIO selected
	GPIO selected									
L	Analog output selected	Setting disabled	Setting disabled	Setting disabled	Maintain previous state	*3	*4	GPIO selected Internal input fixed at "0"	Hi-Z / Internal input fixed at "0"	GPIO selected
	External interrupt enabled selected					Maintain previous state				
	Resource other than above selected	Hi-Z	Hi-Z / Input enabled	Hi-Z / Input enabled		Maintain previous state	Hi-Z / Internal input fixed at "0"			
	GPIO selected									
M	Analog input selected	Hi-Z	Hi-Z / Internal input fixed at "0" / Analog input enabled	Hi-Z / Internal input fixed at "0" / Analog input enabled	Hi-Z / Internal input fixed at "0" / Analog input enabled	Hi-Z / Internal input fixed at "0" / Analog input enabled	Hi-Z / Internal input fixed at "0" / Analog input enabled	Hi-Z / Internal input fixed at "0" / Analog input enabled	Hi-Z / Internal input fixed at "0" / Analog input enabled	Hi-Z / Internal input fixed at "0" / Analog input enabled
	Resource other than above selected	Setting disabled	Setting disabled	Setting disabled	Maintain previous state	Maintain previous state	Hi-Z / Internal input fixed at "0"	GPIO selected Internal input fixed at "0"	Hi-Z / Internal input fixed at "0"	GPIO selected
	GPIO selected									

Pin status type	Function group	Power-on reset or low-voltage detection state	INITX input state	Device internal reset state	Run mode or SLEEP mode state	Timer mode, RTC mode, or STOP mode state		Deep standby RTC mode or Deep standby STOP mode state		Return from Deep standby mode state
		Power supply unstable	Power supply stable		Power supply stable	Power supply stable		Power supply stable		Power supply stable
		-	INITX = 0	INITX = 1	INITX = 1	INITX = 1		INITX = 1		INITX = 1
		-	-	-	-	SPL = 0	SPL = 1	SPL = 0	SPL = 1	-
N	Analog input selected	Hi-Z	Hi-Z / Internal input fixed at "0" / Analog input enabled	Hi-Z / Internal input fixed at "0" / Analog input enabled	Hi-Z / Internal input fixed at "0" / Analog input enabled	Hi-Z / Internal input fixed at "0" / Analog input enabled	Hi-Z / Internal input fixed at "0" / Analog input enabled	Hi-Z / Internal input fixed at "0" / Analog input enabled	Hi-Z / Internal input fixed at "0" / Analog input enabled	Hi-Z / Internal input fixed at "0" / Analog input enabled
	External interrupt enabled selected	Setting disabled	Setting disabled	Setting disabled	Maintain previous state	Maintain previous state	Maintain previous state	GPIO selected Internal input fixed at "0"	Hi-Z / Internal input fixed at "0"	GPIO selected
	Resource other than above selected						Hi-Z / Internal input fixed at "0"			
GPIO selected										

\*1: Oscillation is stopped at Sub Timer mode, Low-speed CR Timer mode, RTC mode, Stop mode, Deep Standby RTC mode, and Deep Standby Stop mode.

\*2: Oscillation is stopped at Stop mode and Deep Standby Stop mode.

\*3: Maintain previous state at Timer mode. GPIO selected Internal input fixed at "0" at RTC mode, Stop mode.

\*4: Maintain previous state at Timer mode. Hi-Z/Internal input fixed at "0" at RTC mode, Stop mode.

## 12. Electrical Characteristics

### 12.1 Absolute Maximum Ratings

Parameter	Symbol	Rating		Unit	Remarks
		Min	Max		
Power supply voltage*1, *2	$V_{CC}$	$V_{SS} - 0.5$	$V_{SS} + 6.5$	V	
Power supply voltage (for USB)*1, *3	$USBV_{CC}$	$V_{SS} - 0.5$	$V_{SS} + 6.5$	V	
Analog power supply voltage*1, *4	$AV_{CC}$	$V_{SS} - 0.5$	$V_{SS} + 6.5$	V	
Analog reference voltage*1, *4	$AV_{RH}$	$V_{SS} - 0.5$	$V_{SS} + 6.5$	V	
Input voltage*1	$V_I$	$V_{SS} - 0.5$	$V_{CC} + 0.5$ ( $\leq 6.5V$ )	V	Except for USB pin
		$V_{SS} - 0.5$	$USBV_{CC} + 0.5$ ( $\leq 6.5V$ )	V	USB pin
		$V_{SS} - 0.5$	$V_{SS} + 6.5$	V	5 V tolerant
Analog pin input voltage*1	$V_{IA}$	$V_{SS} - 0.5$	$AV_{CC} + 0.5$ ( $\leq 6.5V$ )	V	
Output voltage*1	$V_O$	$V_{SS} - 0.5$	$V_{CC} + 0.5$ ( $\leq 6.5V$ )	V	
Clamp maximum current	$I_{CLAMP}$	-2	+2	mA	*8
Clamp total maximum current	$\sum [I_{CLAMP}]$		+20	mA	*8
L level maximum output current*5	$I_{OL}$	-	10	mA	4 mA type
			20	mA	12 mA type
			39	mA	The pin doubled as USB I/O
L level average output current*6	$I_{OLAV}$	-	4	mA	4 mA type
			12	mA	12 mA type
			16.5	mA	The pin doubled as USB I/O
L level total maximum output current	$\sum I_{OL}$	-	100	mA	
L level total average output current*7	$\sum I_{OLAV}$	-	50	mA	
H level maximum output current*5	$I_{OH}$	-	- 10	mA	4 mA type
			- 20	mA	12 mA type
			- 39	mA	The pin doubled as USB I/O
H level average output current*6	$I_{OHAV}$	-	- 4	mA	4 mA type
			- 12	mA	12 mA type
			- 18	mA	The pin doubled as USB I/O
H level total maximum output current	$\sum I_{OH}$	-	- 100	mA	
H level total average output current*7	$\sum I_{OHAV}$	-	- 50	mA	
Power consumption	$P_D$	-	300	mW	
Storage temperature	$T_{STG}$	- 55	+ 150	°C	

\*1: These parameters are based on the condition that  $V_{SS} = AV_{SS} = 0V$ .

\*2:  $V_{CC}$  must not drop below  $V_{SS} - 0.5V$ .

\*3:  $USBV_{CC}$  must not drop below  $V_{SS} - 0.5V$ .

\*4: Ensure that the voltage does not exceed  $V_{CC} + 0.5V$ , for example, when the power is turned on.

\*5: The maximum output current is defined as the value of the peak current flowing through any one of the corresponding pins.

\*6: The average output current is defined as the average current value flowing through any one of the corresponding pins for a 100 ms period.

\*7: The total average output current is defined as the average current value flowing through all of corresponding pins for a 100 ms.

- \*8:
- See “List of Pin Functions” and “I/O Circuit Type” about +B input available pin.
  - Use within recommended operating conditions.
  - Use at DC voltage (current) the +B input.
  - The +B signal should always be applied a limiting resistance placed between the +B signal and the device.
  - The value of the limiting resistance should be set so that when the +B signal is applied the input current to the device pin does not exceed rated values, either instantaneously or for prolonged periods.
  - Note that when the device drive current is low, such as in the low-power consumption modes, the +B input potential may pass through the protective diode and increase the potential at the VCC and AVCC pin, and this may affect other devices.
  - Note that if a +B signal is input when the device power supply is off (not fixed at 0 V), the power supply is provided from the pins, so that incomplete operation may result.
  - The following is a recommended circuit example (I/O equivalent circuit).

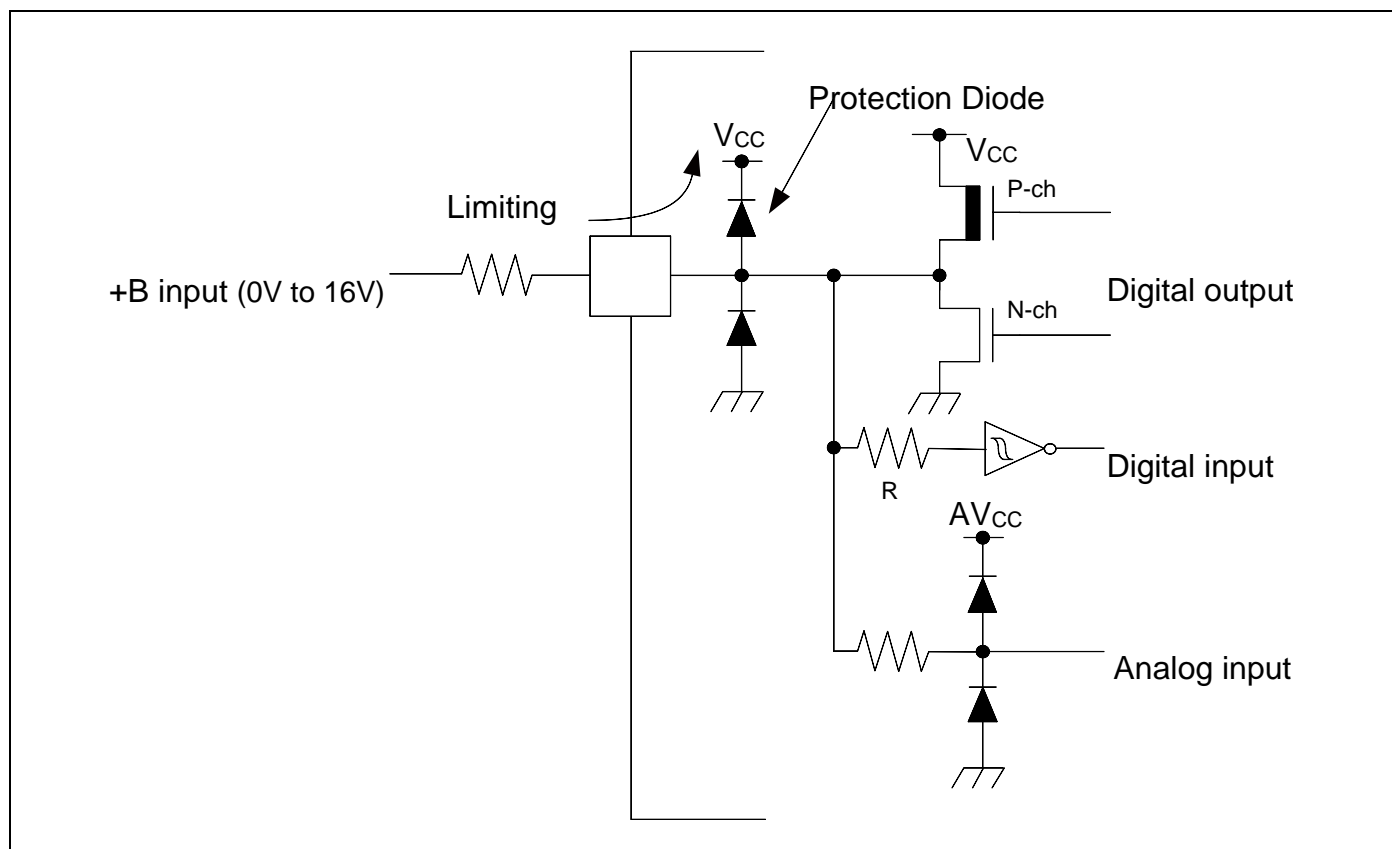

**WARNING:**

- Semiconductor devices can be permanently damaged by application of stress (voltage, current, temperature, etc.) in excess of absolute maximum ratings. Do not exceed these ratings.

**12.2 Recommended Operating Conditions**

 (V<sub>SS</sub> = AV<sub>SS</sub> = AV<sub>RL</sub> = 0.0V)

Parameter	Symbol	Conditions	Value		Unit	Remarks
			Min	Max		
Power supply voltage	V <sub>CC</sub>	-	2.7*4	5.5	V	
Power supply voltage (3V power supply) for USB	USBV <sub>CC</sub>	-	3.0	3.6 (≤ V <sub>CC</sub> )	V	*1
			2.7	5.5 (≤ V <sub>CC</sub> )		*2
Analog power supply voltage	AV <sub>CC</sub>	-	2.7	5.5	V	AV <sub>CC</sub> = V <sub>CC</sub>
Analog reference voltage	AV <sub>RH</sub>	-	2.7	AV <sub>CC</sub>	V	
	AV <sub>RL</sub>	-	AV <sub>SS</sub>	AV <sub>SS</sub>	V	
Smoothing capacitor	C <sub>S</sub>	-	1	10	μF	For Regulator*3
Operating temperature	T <sub>A</sub>	-	- 40	+ 105	°C	

\*1: When P81/UDP0 and P80/UDM0 pins are used as USB (UDP0, UDM0).

\*2: When P81/UDP0 and P80/UDM0 pins are used as GPIO (P81, P80).

\*3: See "C Pin" in "Handling Devices" for the connection of the smoothing capacitor.

\*4: In between less than the minimum power supply voltage and low voltage reset/interrupt detection voltage or more, instruction execution and low voltage detection function by built-in High-speed CR(including Main PLL is used) or built-in Low-speed CR is possible to operate only.

**WARNING:**

- *The recommended operating conditions are required in order to ensure the normal operation of the semiconductor device. All of the device's electrical characteristics are warranted when the device is operated within these ranges. Always use semiconductor devices within their recommended operating condition ranges. Operation outside these ranges may adversely affect reliability and could result in device failure. No warranty is made with respect to uses, operating conditions, or combinations not represented on the data sheet. Users considering application outside the listed conditions are advised to contact their representatives beforehand.*

## 12.3 DC Characteristics

### 12.3.1 Current Rating

( $V_{CC} = AV_{CC} = USBV_{CC} = 2.7V$  to  $5.5V$ ,  $V_{SS} = AV_{SS} = AV_{RL} = 0V$ ,  $T_A = -40^{\circ}C$  to  $+105^{\circ}C$ )

Parameter	Symbol	Pin name	Conditions		Value		Unit	Remarks
					Typ	Max		
Run mode current	$I_{CC}$	VCC	PLL Run mode	CPU: 72 MHz, Peripheral: 36 MHz	32.5	41	mA	*1, *5
				CPU:72 MHz, Peripheral clock stops NOP operation	18	23	mA	*1, *5
			High-speed CR Run mode	CPU/ Peripheral: 4 MHz*2	2.5	3.4	mA	*1
			Sub Run mode	CPU/ Peripheral: 32 kHz	110	980	$\mu A$	*1, *6
			Low-speed CR Run mode	CPU/ Peripheral: 100 kHz	130	1030	$\mu A$	*1
Sleep mode current	$I_{CCS}$		PLL Sleep mode	Peripheral: 36 MHz	22	28	mA	*1, *5
			High-speed CR Sleep mode	Peripheral: 4 MHz*2	1.6	2.6	mA	*1
			Sub Sleep mode	Peripheral: 32 kHz	96	955	$\mu A$	*1, *6
			Low-speed CR Sleep mode	Peripheral: 100 kHz	115	975	$\mu A$	*1

\*1: When all ports are fixed.

\*2: When setting it to 4 MHz by trimming.

\*3:  $T_A = +25^{\circ}C$ ,  $V_{CC} = 5.5V$

\*4:  $T_A = +105^{\circ}C$ ,  $V_{CC} = 5.5V$

\*5: When using the crystal oscillator of 4 MHz(Including the current consumption of the oscillation circuit)

\*6: When using the crystal oscillator of 32 kHz(Including the current consumption of the oscillation circuit)

(V<sub>CC</sub> = AV<sub>CC</sub> = USBV<sub>CC</sub> = 2.7V to 5.5V, V<sub>SS</sub> = AV<sub>SS</sub> = AV<sub>RL</sub> = 0V, T<sub>A</sub> = - 40°C to + 105°C)

Parameter	Symbol	Pin name	Conditions	Value		Unit	Remarks	
				Typ <sup>*2</sup>	Max <sup>*2</sup>			
Timer mode current	I <sub>CCT</sub>	VCC	Main Timer mode	T <sub>A</sub> = + 25°C, When LVD is off	4.1	4.8	mA	*1, *4
				T <sub>A</sub> = + 105°C, When LVD is off	-	5.4	mA	*1, *4
	Sub Timer mode		T <sub>A</sub> = + 25°C, When LVD is off	17	66	μA	*1, *5	
			T <sub>A</sub> = + 105°C, When LVD is off	-	835	μA	*1, *5	
RTC mode current	I <sub>CCR</sub>		RTC mode	T <sub>A</sub> = + 25°C, When LVD is off	15	61	μA	*1, *5
				T <sub>A</sub> = + 105°C, When LVD is off	-	680	μA	*1, *5
Stop mode current	I <sub>CCH</sub>		Stop mode	T <sub>A</sub> = + 25°C, When LVD is off	14	53	μA	*1
				T <sub>A</sub> = + 105°C, When LVD is off	-	600	μA	*1
Deep Standby mode current	I <sub>CCRD</sub>	Deep Standby RTC mode	T <sub>A</sub> = + 25°C, When LVD is off, When RAM is off	2.2	11	μA	*1, *3, *5	
			T <sub>A</sub> = + 25°C, When LVD is off, When RAM is on	6.2	23	μA	*1, *3, *5	
			T <sub>A</sub> = + 105°C, When LVD is off, When RAM is off	-	155	μA	*1, *3, *5	
			T <sub>A</sub> = + 105°C, When LVD is off, When RAM is on	-	215	μA	*1, *3, *5	
	I <sub>CCHD</sub>	Deep Standby Stop mode	T <sub>A</sub> = + 25°C, When LVD is off, When RAM is off	1.6	9.6	μA	*1, *3	
			T <sub>A</sub> = + 25°C, When LVD is off, When RAM is on	5.6	22	μA	*1, *3	
			T <sub>A</sub> = + 105°C, When LVD is off, When RAM is off	-	150	μA	*1, *3	
			T <sub>A</sub> = + 105°C, When LVD is off, When RAM is on	-	210	μA	*1, *3	

\*1: When all ports are fixed.

\*2: V<sub>CC</sub>=5.5 V

\*3: RAM on/off setting is on-chip SRAM only.

\*4: When using the crystal oscillator of 4 MHz(Including the current consumption of the oscillation circuit)

\*5: When using the crystal oscillator of 32 kHz(Including the current consumption of the oscillation circuit)

**Low-Voltage Detection Current**
 $(V_{CC} = 2.7V \text{ to } 5.5V, V_{SS} = 0V, T_A = -40^{\circ}C \text{ to } +105^{\circ}C)$ 

Parameter	Symbol	Pin name	Conditions	Value		Unit	Remarks
				Typ	Max		
Low-voltage detection circuit (LVD) power supply current	I <sub>CC</sub> LVD	VCC	At operation for reset V <sub>CC</sub> = 5.5 V	0.13	0.3	μA	At not detect
			At operation for interrupt V <sub>CC</sub> = 5.5 V	0.13	0.3	μA	At not detect

**Flash Memory Current**
 $(V_{CC} = 2.7V \text{ to } 5.5V, V_{SS} = 0V, T_A = -40^{\circ}C \text{ to } +105^{\circ}C)$ 

Parameter	Symbol	Pin name	Conditions	Value		Unit	Remarks
				Typ	Max		
Flash memory write/erase current	I <sub>CC</sub> FLASH	VCC	At Write/Erase	9.5	11.2	mA	*

\*: The current at which to write or erase Flash memory, "I<sub>CC</sub>FLASH" is added to "I<sub>CC</sub>".

**A/D Converter Current**
 $(V_{CC} = AV_{CC} = 2.7V \text{ to } 5.5V, V_{SS} = AV_{SS} = AV_{RL} = 0V, T_A = -40^{\circ}C \text{ to } +105^{\circ}C)$ 

Parameter	Symbol	Pin name	Conditions	Value		Unit	Remarks
				Typ	Max		
Power supply current	I <sub>CC</sub> AD	AVCC	At 1unit operation	0.69	0.90	mA	
			At stop	0.25	25.84	μA	
Reference power supply current	I <sub>CC</sub> AVRH	AVRH	At 1unit operation AVRH=5.5 V	1.1	1.97	mA	
			At stop	0.2	3.4	μA	

**D/A Converter Current**
 $(V_{CC} = AV_{CC} = 2.7V \text{ to } 5.5V, V_{SS} = AV_{SS} = 0V, T_A = -40^{\circ}C \text{ to } +105^{\circ}C)$ 

Parameter	Symbol	Pin name	Conditions	Value			Unit	Remarks
				Min	Typ	Max		
Power supply current*1	I <sub>DDA</sub> *2	AVCC	At 1unit operation AV <sub>CC</sub> =3.3 V	250	315	380	μA	
			At 1unit operation AV <sub>CC</sub> =5.0 V	380	475	580	μA	
	I <sub>DSA</sub>		At stop	-	-	16	μA	

\*1: No-load

\*2: Generates the max current by the CODE about 0x200

**12.3.2 Pin Characteristics**
 $(V_{CC} = USBV_{CC} = AV_{CC} = 2.7V \text{ to } 5.5V, V_{SS} = AV_{SS} = AV_{RL} = 0V, T_A = -40^{\circ}C \text{ to } +105^{\circ}C)$ 

Parameter	Symbol	Pin name	Conditions	Value			Unit	Remarks
				Min	Typ	Max		
H level input voltage (hysteresis input)	$V_{IHS}$	CMOS hysteresis input pin, MD0, MD1	-	$V_{CC} \times 0.8$	-	$V_{CC} + 0.3$	V	
		5 V tolerant input pin	-	$V_{CC} \times 0.8$	-	$V_{SS} + 5.5$	V	
L level input voltage (hysteresis input)	$V_{ILS}$	CMOS hysteresis input pin, MD0, MD1	-	$V_{SS} - 0.3$	-	$V_{CC} \times 0.2$	V	
		5 V tolerant input pin	-	$V_{SS} - 0.3$	-	$V_{CC} \times 0.2$	V	
H level output voltage	$V_{OH}$	4 mA type	$V_{CC} \geq 4.5 V, I_{OH} = -4 \text{ mA}$	$V_{CC} - 0.5$	-	$V_{CC}$	V	
			$V_{CC} < 4.5 V, I_{OH} = -2 \text{ mA}$					
		12 mA type	$V_{CC} \geq 4.5 V, I_{OH} = -12 \text{ mA}$	$V_{CC} - 0.5$	-	$V_{CC}$	V	
$V_{CC} < 4.5 V, I_{OH} = -8 \text{ mA}$								
The pin doubled as USB I/O			$USBV_{CC} \geq 4.5 V, I_{OH} = -18.0 \text{ mA}$	$USBV_{CC} - 0.4$	-	$USBV_{CC}$	V	
			$USBV_{CC} < 4.5 V, I_{OH} = -12.0 \text{ mA}$					
L level output voltage	$V_{OL}$	4 mA type	$V_{CC} \geq 4.5 V, I_{OL} = 4 \text{ mA}$	$V_{SS}$	-	0.4	V	
			$V_{CC} < 4.5 V, I_{OL} = 2 \text{ mA}$					
		12 mA type	$V_{CC} \geq 4.5 V, I_{OL} = 12 \text{ mA}$	$V_{SS}$	-	0.4	V	
$V_{CC} < 4.5 V, I_{OL} = 8 \text{ mA}$								
The pin doubled as USB I/O			$USBV_{CC} \geq 4.5 V, I_{OL} = 16.5 \text{ mA}$	$V_{SS}$	-	0.4	V	
			$USBV_{CC} < 4.5 V, I_{OL} = 10.5 \text{ mA}$					
Input leak current	$I_{IL}$	-	-	-5	-	+5	$\mu A$	
Pull-up resistance value	$R_{PU}$	Pull-up pin	$V_{CC} \geq 4.5 V$	33	50	90	k $\Omega$	
			$V_{CC} < 4.5 V$	-	-	180		
Input capacitance	$C_{IN}$	Other than VCC, USBVCC, VSS, AVCC, AVSS, AVRH, AVRL	-	-	5	15	pF	

## 12.4 AC Characteristics

### 12.4.1 Main Clock Input Characteristics

( $V_{CC} = 2.7V$  to  $5.5V$ ,  $V_{SS} = 0V$ ,  $T_A = -40^{\circ}C$  to  $+105^{\circ}C$ )

Parameter	Symbol	Pin name	Conditions	Value		Unit	Remarks	
				Min	Max			
Input frequency	$f_{CH}$	X0, X1	$V_{CC} \geq 4.5 V$	4	48	MHz	When crystal oscillator is connected	
			$V_{CC} < 4.5 V$	4	20			
			$V_{CC} \geq 4.5 V$	4	48	MHz	When using external Clock	
			$V_{CC} < 4.5 V$	4	20			
Input clock cycle	$t_{CYLH}$		$V_{CC} \geq 4.5 V$	20.83	250	ns	When using external Clock	
			$V_{CC} < 4.5 V$	50	250			
Input clock pulse width	-			$PWH/t_{CYLH}$ , $PWL/t_{CYLH}$	45	55	%	When using external Clock
Input clock rising time and falling time	$t_{CF}$ , $t_{CR}$			-	-	5	ns	When using external Clock
Internal operating clock frequency <sup>*1</sup>	$f_{CM}$	-	-	-	72	MHz	Master clock	
	$f_{CC}$	-	-	-	72	MHz	Base clock (HCLK/FCLK)	
	$f_{CP0}$	-	-	-	40	MHz	APB0 bus clock <sup>*2</sup>	
	$f_{CP1}$	-	-	-	40	MHz	APB1 bus clock <sup>*2</sup>	
	$f_{CP2}$	-	-	-	40	MHz	APB2 bus clock <sup>*2</sup>	
Internal operating clock cycle time <sup>*1</sup>	$t_{CYCC}$	-	-	13.8	-	ns	Base clock (HCLK/FCLK)	
	$t_{CYCP0}$	-	-	25	-	ns	APB0 bus clock <sup>*2</sup>	
	$t_{CYCP1}$	-	-	25	-	ns	APB1 bus clock <sup>*2</sup>	
	$t_{CYCP2}$	-	-	25	-	ns	APB2 bus clock <sup>*2</sup>	

\*1: For more information about each internal operating clock, see "Chapter: Clock" in "FM3 Family Peripheral Manual".

\*2: For about each APB bus which each peripheral is connected to, see "Block Diagram" in this datasheet.

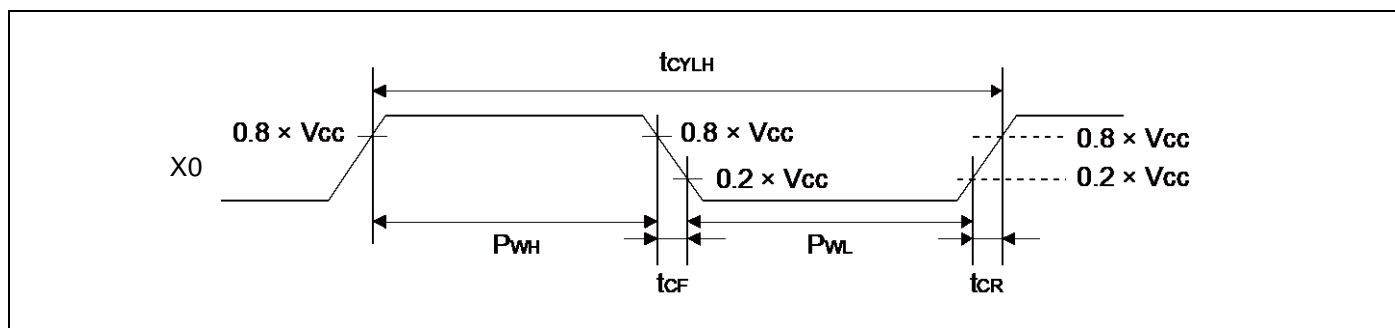

**12.4.2 Sub Clock Input Characteristics**

 ( $V_{CC} = 2.7V$  to  $5.5V$ ,  $V_{SS} = 0V$ ,  $T_A = -40^{\circ}C$  to  $+105^{\circ}C$ )

Parameter	Symbol	Pin name	Conditions	Value			Unit	Remarks
				Min	Typ	Max		
Input frequency	$1/t_{CYLL}$	X0A, X1A	-	-	32.768	-	kHz	When crystal oscillator is connected
			-	32	-	100		kHz
Input clock cycle	$t_{CYLL}$		-	10	-	31.25	$\mu s$	When using external clock
Input clock pulse width	-		$P_{WH}/t_{CYLL}$ , $P_{WL}/t_{CYLL}$	45	-	55	%	When using external clock

\*: See "Sub crystal oscillator" in "Handling Devices" for the crystal oscillator used.

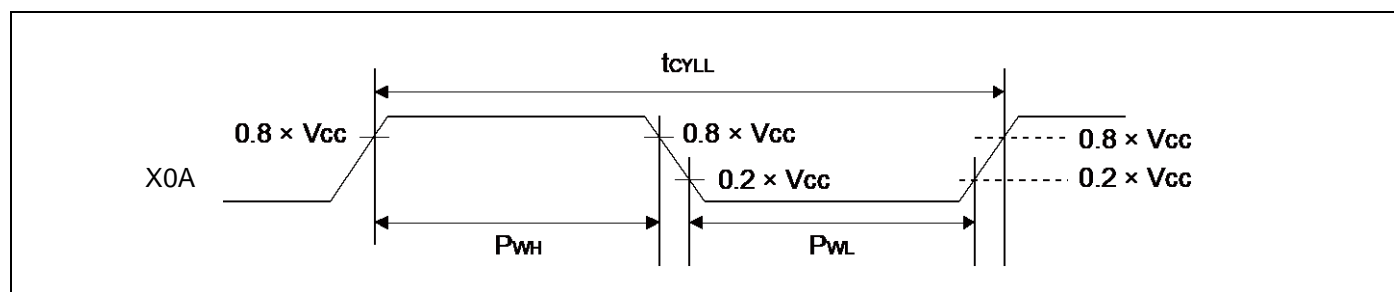

**12.4.3 Built-in CR Oscillation Characteristics**
**Built-in High-speed CR**
 $(V_{CC} = 2.7V \text{ to } 5.5V, V_{SS} = 0V, T_A = -40^{\circ}C \text{ to } +105^{\circ}C)$ 

Parameter	Symbol	Conditions	Value			Unit	Remarks
			Min	Typ	Max		
Clock frequency	$f_{CRH}$	$T_A = +25^{\circ}C$	3.92	4	4.08	MHz	When trimming*1
		$T_A = 0^{\circ}C \text{ to } +85^{\circ}C$	3.9	4	4.1		
		$T_A = -40^{\circ}C \text{ to } +105^{\circ}C$	3.88	4	4.12		
		$T_A = +25^{\circ}C$ $V_{CC} \leq 3.6V$	3.94	4	4.06		
		$T_A = -20^{\circ}C \sim +85^{\circ}C$ $V_{CC} \leq 3.6V$	3.92	4	4.08		
		$T_A = -20^{\circ}C \sim +105^{\circ}C$ $V_{CC} \leq 3.6V$	3.9	4	4.1		
		$T_A = -40^{\circ}C \text{ to } +105^{\circ}C$	2.8	4	5.2		When not trimming
Frequency stabilization time	$t_{CRWT}$	-	-	-	30	$\mu s$	*2

\*1: In the case of using the values in CR trimming area of Flash memory at shipment for frequency/temperature trimming.

\*2: This is the time to stabilize the frequency of high-speed CR clock after setting trimming value.

This period is able to use high-speed CR clock as source clock.

**Built-in Low-speed CR**
 $(V_{CC} = 2.7V \text{ to } 5.5V, V_{SS} = 0V, T_A = -40^{\circ}C \text{ to } +105^{\circ}C)$ 

Parameter	Symbol	Conditions	Value			Unit	Remarks
			Min	Typ	Max		
Clock frequency	$f_{CRL}$	-	50	100	150	kHz	

**12.4.4 Operating Conditions of Main and USB PLL (In the case of using main clock for input of PLL)**

(V<sub>CC</sub> = 2.7V to 5.5V, V<sub>SS</sub> = 0V, T<sub>A</sub> = - 40°C to + 105°C)

Parameter	Symbol	Value			Unit	Remarks
		Min	Typ	Max		
PLL oscillation stabilization wait time* <sup>1</sup> (LOCK UP time)	t <sub>LOCK</sub>	100	-	-	μs	
PLL input clock frequency	f <sub>PLLI</sub>	4	-	16	MHz	
PLL multiplication rate	-	5	-	37	multiplier	
PLL macro oscillation clock frequency	f <sub>PLLO</sub>	75	-	150	MHz	
Main PLL clock frequency* <sup>2</sup>	f <sub>CLKPLL</sub>	-	-	72	MHz	
USB clock frequency* <sup>3</sup>	f <sub>CLKSPLL</sub>	-	-	48	MHz	After the M frequency division

\*1: Time from when the PLL starts operating until the oscillation stabilizes.

\*2: For more information about Main PLL clock (CLKPLL), see “Chapter 2-1: Clock” in “FM3 Family Peripheral Manual”.

\*3: For more information about USB clock, see “Chapter 2-2: USB Clock Generation” in “FM3 Family Peripheral Manual Communication Macro Part”.

**12.4.5 Operating Conditions of Main PLL (In the case of using built-in high-speed CR for input clock of Main PLL)**

(V<sub>CC</sub> = 2.7V to 5.5V, V<sub>SS</sub> = 0V, T<sub>A</sub> = - 40°C to + 105°C)

Parameter	Symbol	Value			Unit	Remarks
		Min	Typ	Max		
PLL oscillation stabilization wait time* <sup>1</sup> (LOCK UP time)	t <sub>LOCK</sub>	100	-	-	μs	
PLL input clock frequency	f <sub>PLLI</sub>	3.8	4	4.2	MHz	
PLL multiplication rate	-	19	-	35	multiplier	
PLL macro oscillation clock frequency	f <sub>PLLO</sub>	72	-	150	MHz	
Main PLL clock frequency* <sup>2</sup>	f <sub>CLKPLL</sub>	-	-	72	MHz	

\*1: Time from when the PLL starts operating until the oscillation stabilizes.

\*2: For more information about Main PLL clock (CLKPLL), see “Chapter 2-1: Clock” in “FM3 Family Peripheral Manual”.

**Note:**

- Make sure to input to the Main PLL source clock, the high-speed CR clock (CLKHC) that the frequency/temperature has been trimmed.  
When setting PLL multiple rate, please take the accuracy of the built-in high-speed CR clock into account and prevent the master clock from exceeding the maximum frequency.

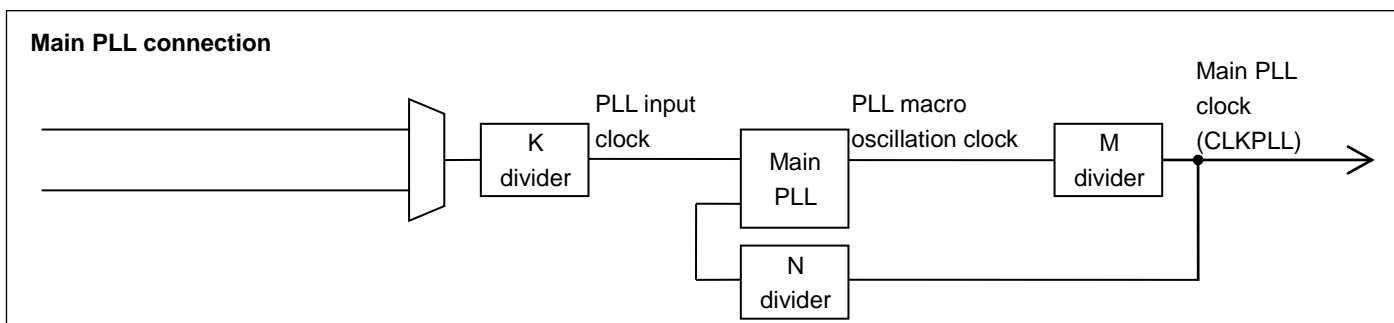

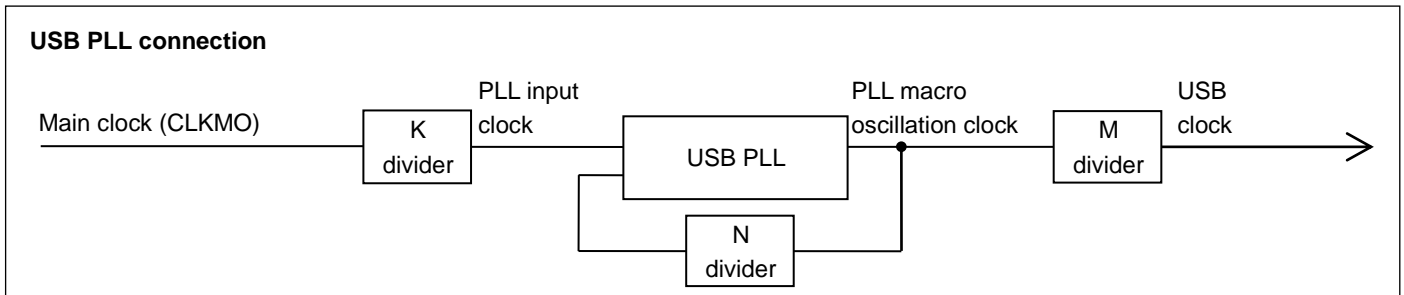

**12.4.6 Reset Input Characteristics**

( $V_{CC} = 2.7V$  to  $5.5V$ ,  $V_{SS} = 0V$ ,  $T_A = -40^{\circ}C$  to  $+105^{\circ}C$ )

Parameter	Symbol	Pin name	Conditions	Value		Unit	Remarks
				Min	Max		
Reset input time	$t_{INITX}$	INITX	-	500	-	ns	

**12.4.7 Power-on Reset Timing**

( $V_{SS} = 0V$ ,  $T_A = -40^{\circ}C$  to  $+105^{\circ}C$ )

Parameter	Symbol	Pin name	Conditions	Value			Unit	Remarks
				Min	Typ	Max		
Power supply shut down time	$t_{OFF}$	VCC	-	1	-	-	ms	*1
Power ramp rate	$dV/dt$		$V_{CC}: 0.2V$ to $2.70V$	0.3	-	1000	mV/ $\mu$ s	*2
Time until releasing Power-on reset	$t_{PRT}$		-	1.34	-	18.6	ms	

\*1:  $V_{CC}$  must be held below 0.2 V for minimum period of  $t_{OFF}$ . Improper initialization may occur if this condition is not met.

\*2: This  $dV/dt$  characteristic is applied at the power-on of cold start ( $t_{OFF} > 1$  ms).

**Note:**

- If  $t_{OFF}$  cannot be satisfied designs must assert external reset(INITX) at power-up and at any brownout event per 12.4.6.

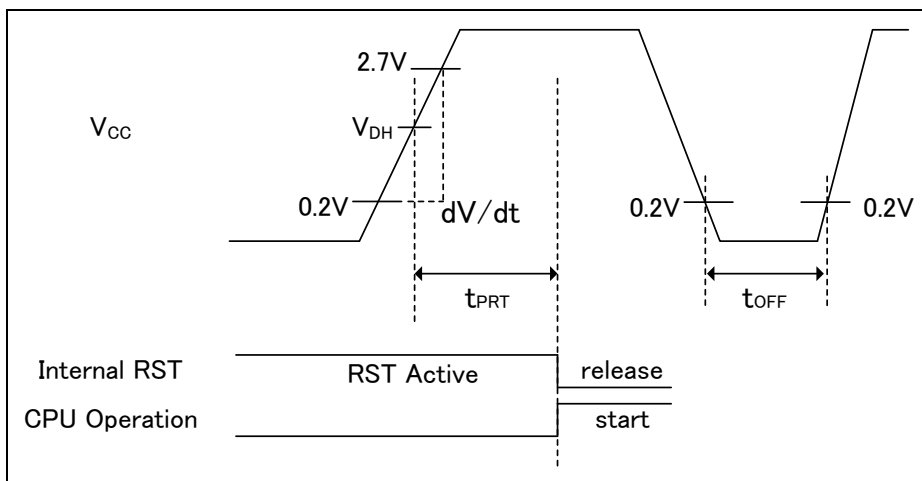

**Glossary**

- $V_{DH}$ : detection voltage (when  $SVHR=00000$ ) of Low-Voltage detection reset. See "12.8. Low-Voltage Detection Characteristics".

**12.4.8 Base Timer Input Timing**
**Timer input timing**

 ( $V_{CC} = 2.7V$  to  $5.5V$ ,  $V_{SS} = 0V$ ,  $T_A = -40^{\circ}C$  to  $+105^{\circ}C$ )

Parameter	Symbol	Pin name	Conditions	Value		Unit	Remarks
				Min	Max		
Input pulse width	$t_{TIWH}$ , $t_{TIWL}$	TIOAn/TIOBn (when using as ECK, TIN)	-	$2t_{CYCP}$	-	ns	

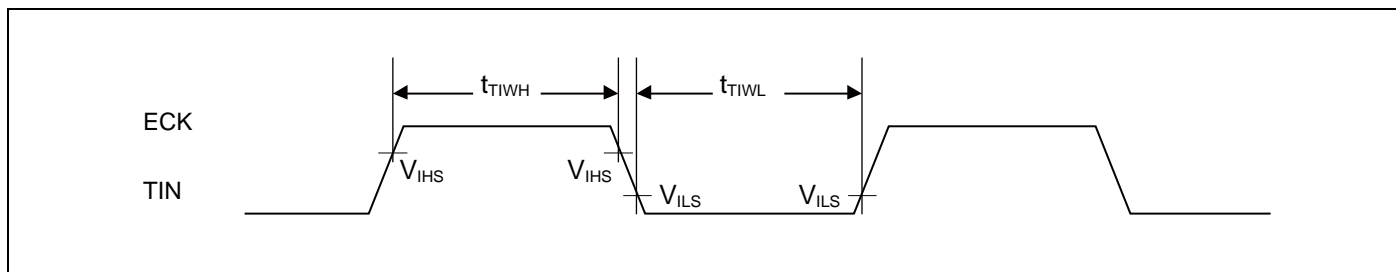
**Trigger input timing**

 ( $V_{CC} = 2.7V$  to  $5.5V$ ,  $V_{SS} = 0V$ ,  $T_A = -40^{\circ}C$  to  $+105^{\circ}C$ )

Parameter	Symbol	Pin name	Conditions	Value		Unit	Remarks
				Min	Max		
Input pulse width	$t_{TRGH}$ , $t_{TRGL}$	TIOAn/TIOBn (when using as TGIN)	-	$2t_{CYCP}$	-	ns	

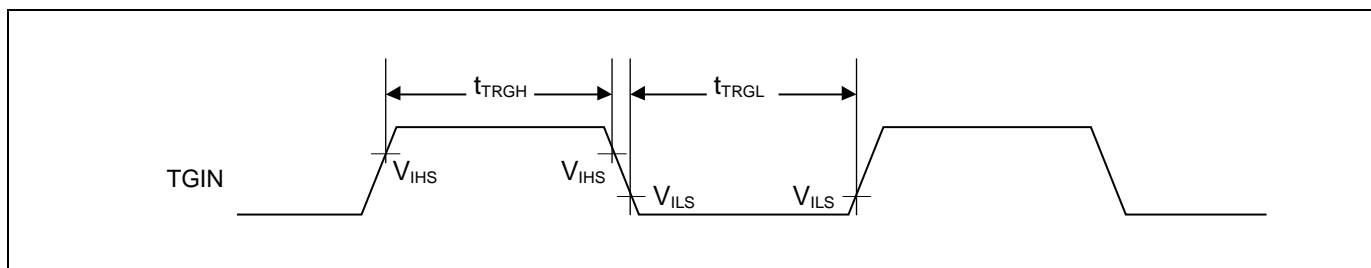
**Note:**

- $t_{CYCP}$  indicates the APB bus clock cycle time.  
About the APB bus number which the Base Timer is connected to, see "Block Diagram" in this data sheet.

**12.4.9 CSIO/UART Timing**
**CSIO (SPI = 0, SCINV = 0)**

 ( $V_{CC} = 2.7V$  to  $5.5V$ ,  $V_{SS} = 0V$ ,  $T_A = -40^{\circ}C$  to  $+105^{\circ}C$ )

Parameter	Symbol	Pin name	Conditions	$V_{CC} < 4.5 V$		$V_{CC} \geq 4.5 V$		Unit
				Min	Max	Min	Max	
Baud rate	-	-	-	-	8	-	8	Mbps
Serial clock cycle time	$t_{SCYC}$	SCKx	Master mode	$4t_{CYCP}$	-	$4t_{CYCP}$	-	ns
SCK ↓ → SOT delay time	$t_{SLOVI}$	SCKx, SOTx		- 30	+ 30	- 20	+ 20	ns
SIN → SCK ↑ setup time	$t_{IVSHI}$	SCKx, SINx		50	-	30	-	ns
SCK ↑ → SIN hold time	$t_{SHIXI}$	SCKx, SINx		0	-	0	-	ns
Serial clock L pulse width	$t_{SLSH}$	SCKx	Slave mode	$2t_{CYCP} - 10$	-	$2t_{CYCP} - 10$	-	ns
Serial clock H pulse width	$t_{SHSL}$	SCKx		$t_{CYCP} + 10$	-	$t_{CYCP} + 10$	-	ns
SCK ↓ → SOT delay time	$t_{SLOVE}$	SCKx, SOTx		-	50	-	30	ns
SIN → SCK ↑ setup time	$t_{IVSHE}$	SCKx, SINx		10	-	10	-	ns
SCK ↑ → SIN hold time	$t_{SHIXE}$	SCKx, SINx		20	-	20	-	ns
SCK falling time	$t_F$	SCKx		-	5	-	5	ns
SCK rising time	$t_R$	SCKx		-	5	-	5	ns

**Notes:**

- The above characteristics apply to CLK synchronous mode.
- $t_{CYCP}$  indicates the APB bus clock cycle time.
- About the APB bus number which Multi-function serial is connected to, see "Block Diagram" in this data sheet.
- These characteristics only guarantee the same relocate port number.
- For example, the combination of SCKx\_0 and SOTx\_1 is not guaranteed.
- When the external load capacitance  $C_L = 30 pF$ .

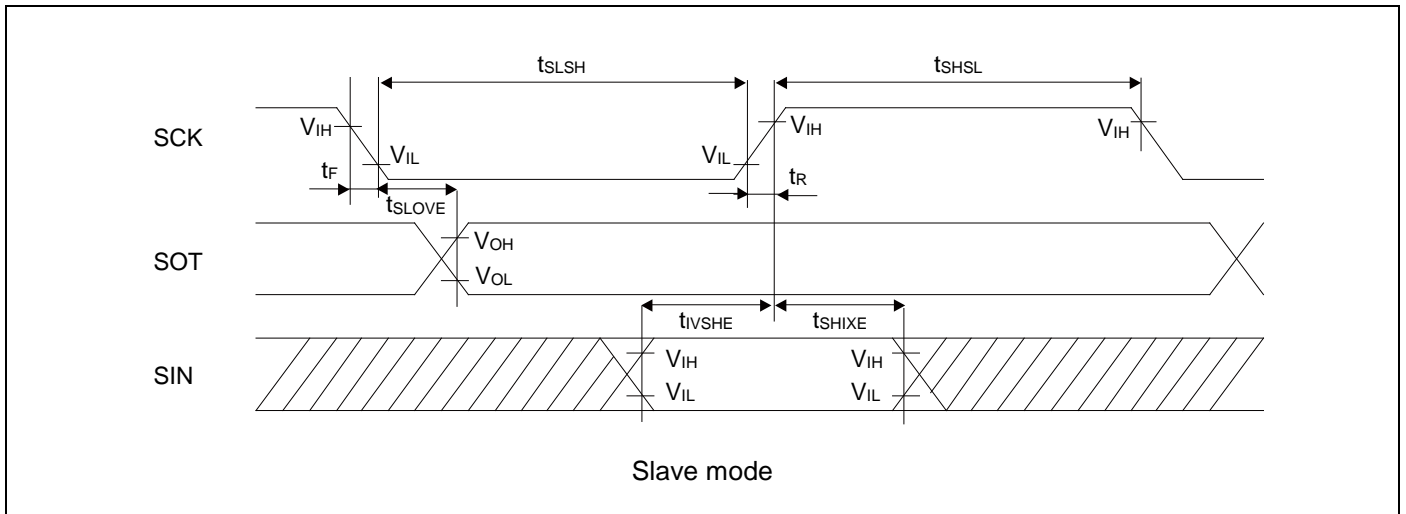
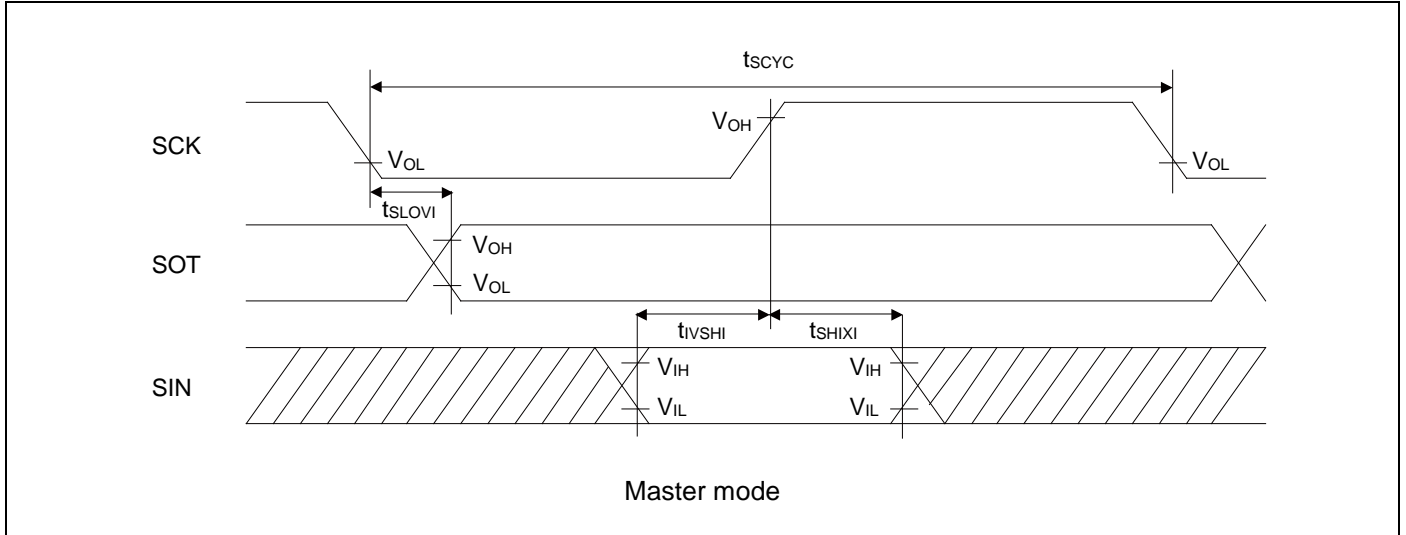

**CSIO (SPI = 0, SCINV = 1)**

 (V<sub>CC</sub> = 2.7V to 5.5V, V<sub>SS</sub> = 0V, T<sub>A</sub> = - 40°C to + 105°C)

Parameter	Symbol	Pin name	Conditions	V <sub>CC</sub> < 4.5 V		V <sub>CC</sub> ≥ 4.5 V		Unit
				Min	Max	Min	Max	
Baud rate	-	-	-	-	8	-	8	Mbps
Serial clock cycle time	t <sub>SCYC</sub>	SCKx	Master mode	4t <sub>CYCP</sub>	-	4t <sub>CYCP</sub>	-	ns
SCK ↑ → SOT delay time	t <sub>SHOVI</sub>	SCKx, SOTx		- 30	+ 30	- 20	+ 20	ns
SIN → SCK ↓ setup time	t <sub>IVSLI</sub>	SCKx, SINx		50	-	30	-	ns
SCK ↓ → SIN hold time	t <sub>SLIXI</sub>	SCKx, SINx		0	-	0	-	ns
Serial clock L pulse width	t <sub>SLSH</sub>	SCKx		2t <sub>CYCP</sub> - 10	-	2t <sub>CYCP</sub> - 10	-	ns
Serial clock H pulse width	t <sub>SHSL</sub>	SCKx	t <sub>CYCP</sub> + 10	-	t <sub>CYCP</sub> + 10	-	ns	
SCK ↑ → SOT delay time	t <sub>SHOVE</sub>	SCKx, SOTx	Slave mode	-	50	-	30	ns
SIN → SCK ↓ setup time	t <sub>IVSLE</sub>	SCKx, SINx		10	-	10	-	ns
SCK ↓ → SIN hold time	t <sub>SLIXE</sub>	SCKx, SINx		20	-	20	-	ns
SCK falling time	t <sub>F</sub>	SCKx		-	5	-	5	ns
SCK rising time	t <sub>R</sub>	SCKx		-	5	-	5	ns

**Notes:**

- The above characteristics apply to CLK synchronous mode.
- t<sub>CYCP</sub> indicates the APB bus clock cycle time.
- About the APB bus number which Multi-function serial is connected to, see “Block Diagram” in this data sheet.
- These characteristics only guarantee the same relocate port number.
- For example, the combination of SCKx\_0 and SOTx\_1 is not guaranteed.
- When the external load capacitance C<sub>L</sub> = 30 pF.

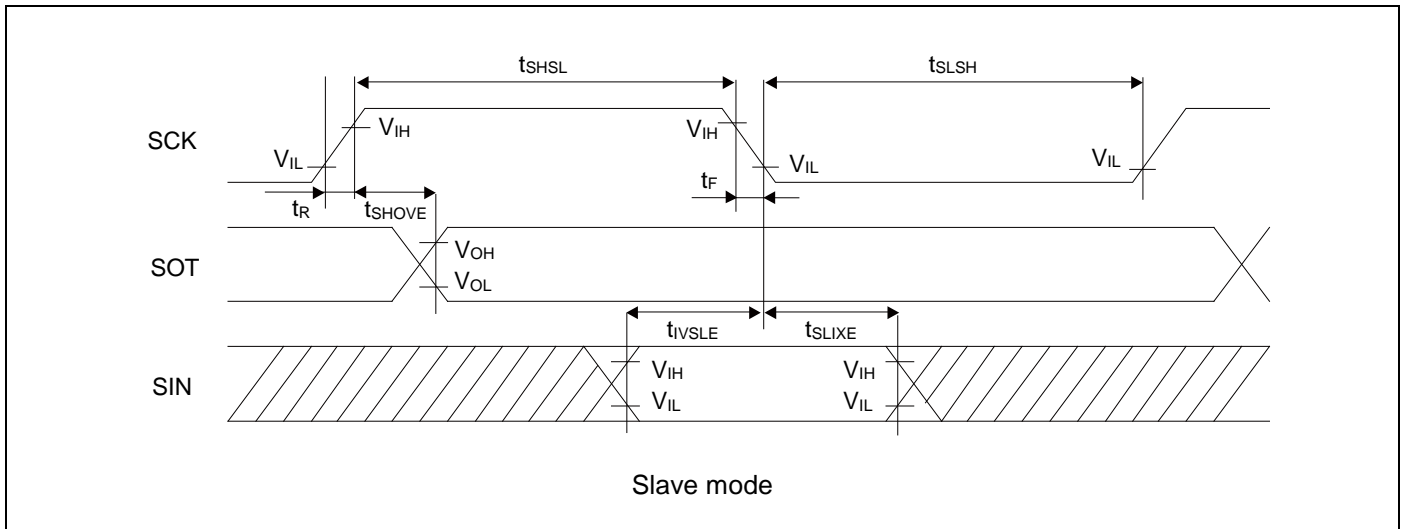
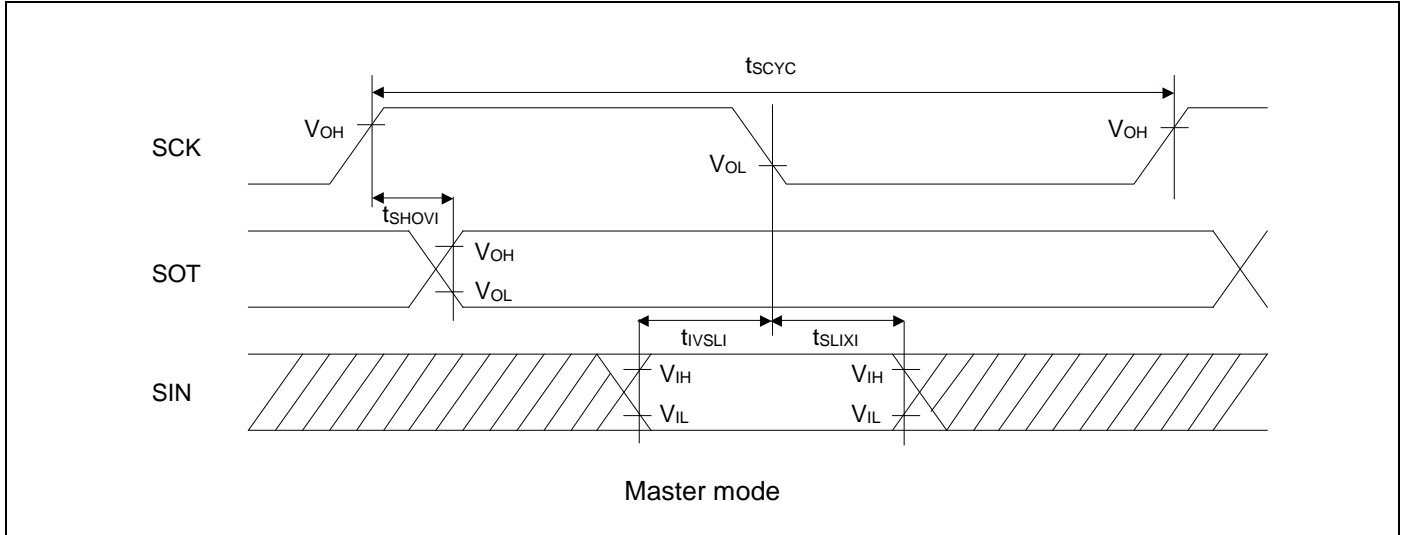

**CSIO (SPI = 1, SCINV = 0)**

 (V<sub>CC</sub> = 2.7V to 5.5V, V<sub>SS</sub> = 0V, T<sub>A</sub> = - 40°C to + 105°C)

Parameter	Symbol	Pin name	Conditions	V <sub>CC</sub> < 4.5 V		V <sub>CC</sub> ≥ 4.5 V		Unit
				Min	Max	Min	Max	
Baud rate	-	-	-	-	8	-	8	Mbps
Serial clock cycle time	t <sub>SCYC</sub>	SCKx	Master mode	4t <sub>CYCP</sub>	-	4t <sub>CYCP</sub>	-	ns
SCK ↑ → SOT delay time	t <sub>SHOVI</sub>	SCKx, SOTx		- 30	+ 30	- 20	+ 20	ns
SIN → SCK ↓ setup time	t <sub>IVSLI</sub>	SCKx, SINx		50	-	30	-	ns
SCK ↓ → SIN hold time	t <sub>SLIXI</sub>	SCKx, SINx		0	-	0	-	ns
SOT → SCK ↓ delay time	t <sub>SOVLI</sub>	SCKx, SOTx		2t <sub>CYCP</sub> - 30	-	2t <sub>CYCP</sub> - 30	-	ns
Serial clock L pulse width	t <sub>SLSH</sub>	SCKx		2t <sub>CYCP</sub> - 10	-	2t <sub>CYCP</sub> - 10	-	ns
Serial clock H pulse width	t <sub>SHSL</sub>	SCKx	t <sub>CYCP</sub> + 10	-	t <sub>CYCP</sub> + 10	-	ns	
SCK ↑ → SOT delay time	t <sub>SHOVE</sub>	SCKx, SOTx	Slave mode	-	50	-	30	ns
SIN → SCK ↓ setup time	t <sub>IVSLE</sub>	SCKx, SINx		10	-	10	-	ns
SCK ↓ → SIN hold time	t <sub>SLIXE</sub>	SCKx, SINx		20	-	20	-	ns
SCK falling time	t <sub>F</sub>	SCKx		-	5	-	5	ns
SCK rising time	t <sub>R</sub>	SCKx		-	5	-	5	ns

**Notes:**

- The above characteristics apply to CLK synchronous mode.
- t<sub>CYCP</sub> indicates the APB bus clock cycle time.
- About the APB bus number which Multi-function serial is connected to, see “Block Diagram” in this data sheet.
- These characteristics only guarantee the same relocate port number.
- For example, the combination of SCKx\_0 and SOTx\_1 is not guaranteed.
- When the external load capacitance C<sub>L</sub> = 30 pF.

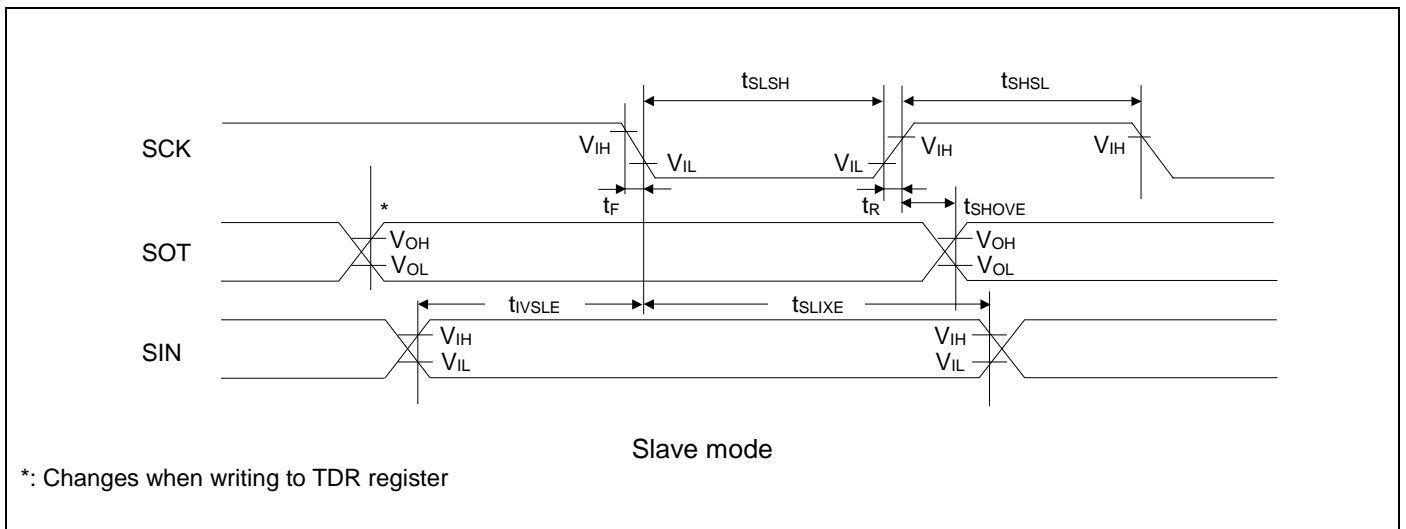
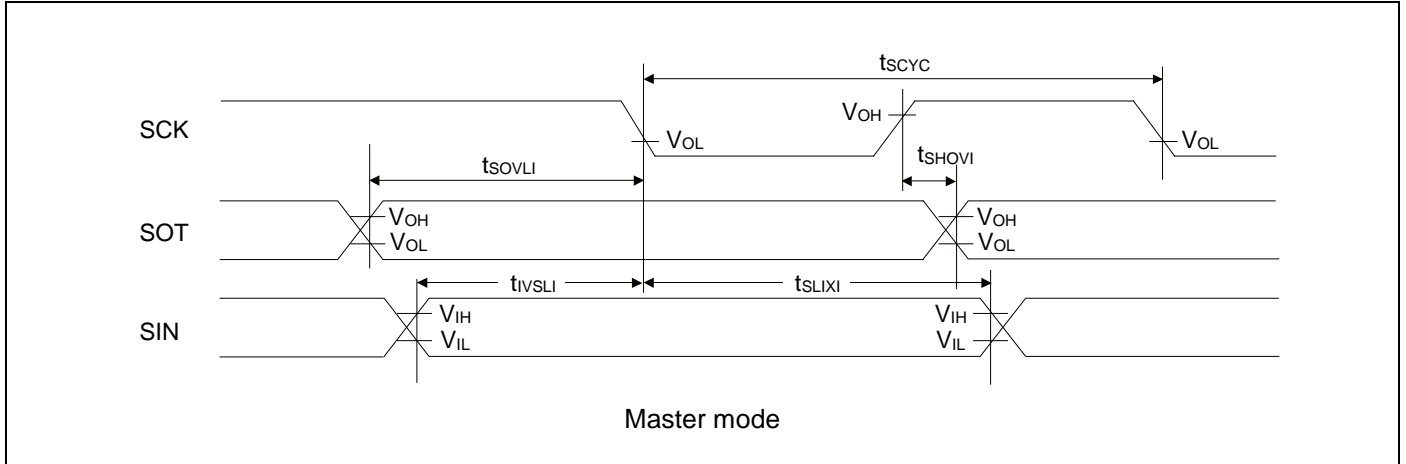

**CSIO (SPI = 1, SCINV = 1)**

 (V<sub>CC</sub> = 2.7V to 5.5V, V<sub>SS</sub> = 0V, T<sub>A</sub> = - 40°C to + 105°C)

Parameter	Symbol	Pin name	Conditions	V <sub>CC</sub> < 4.5 V		V <sub>CC</sub> ≥ 4.5 V		Unit
				Min	Max	Min	Max	
Baud rate	-	-	-	-	8	-	8	Mbps
Serial clock cycle time	t <sub>SCYC</sub>	SCKx	Master mode	4t <sub>CYCP</sub>	-	4t <sub>CYCP</sub>	-	ns
SCK ↓ → SOT delay time	t <sub>SLOVI</sub>	SCKx, SOTx		- 30	+ 30	- 20	+ 20	ns
SIN → SCK ↑ setup time	t <sub>IVSHI</sub>	SCKx, SINx		50	-	30	-	ns
SCK ↑ → SIN hold time	t <sub>SHIXI</sub>	SCKx, SINx		0	-	0	-	ns
SOT → SCK ↑ delay time	t <sub>SOVHI</sub>	SCKx, SOTx		2t <sub>CYCP</sub> - 30	-	2t <sub>CYCP</sub> - 30	-	ns
Serial clock L pulse width	t <sub>SLSH</sub>	SCKx		2t <sub>CYCP</sub> - 10	-	2t <sub>CYCP</sub> - 10	-	ns
Serial clock H pulse width	t <sub>SHSL</sub>	SCKx	t <sub>CYCP</sub> + 10	-	t <sub>CYCP</sub> + 10	-	ns	
SCK ↓ → SOT delay time	t <sub>SLOVE</sub>	SCKx, SOTx	Slave mode	-	50	-	30	ns
SIN → SCK ↑ setup time	t <sub>IVSHE</sub>	SCKx, SINx		10	-	10	-	ns
SCK ↑ → SIN hold time	t <sub>SHIXE</sub>	SCKx, SINx		20	-	20	-	ns
SCK falling time	t <sub>F</sub>	SCKx		-	5	-	5	ns
SCK rising time	t <sub>R</sub>	SCKx		-	5	-	5	ns

**Notes:**

- The above characteristics apply to CLK synchronous mode.
- t<sub>CYCP</sub> indicates the APB bus clock cycle time.
- About the APB bus number which Multi-function serial is connected to, see "Block Diagram" in this data sheet.
- These characteristics only guarantee the same relocate port number.
- For example, the combination of SCKx\_0 and SOTx\_1 is not guaranteed.
- When the external load capacitance C<sub>L</sub> = 30 pF.

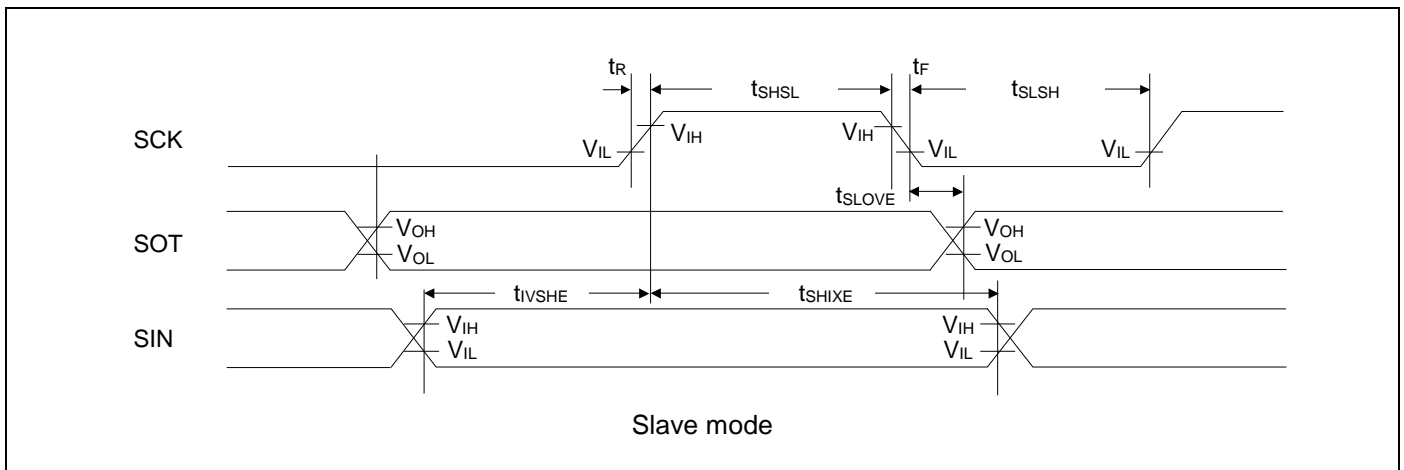
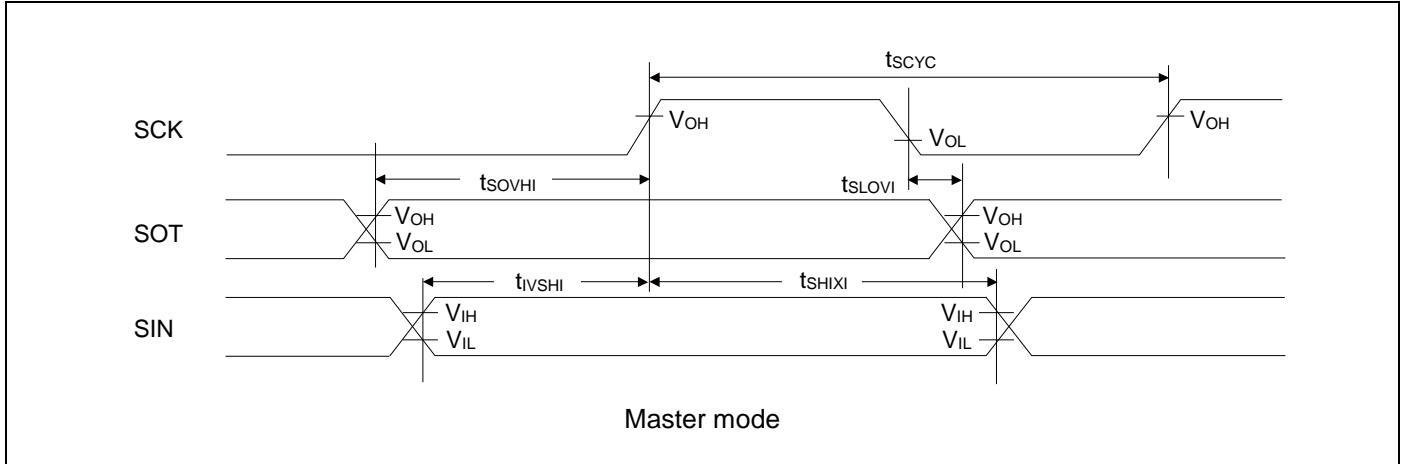
**UART external clock input (EXT = 1)**
 $(V_{CC} = 2.7V \text{ to } 5.5V, V_{SS} = 0V, T_A = -40^{\circ}C \text{ to } +105^{\circ}C)$ 

Parameter	Symbol	Conditions	Min	Max	Unit	Remarks
Serial clock L pulse width	$t_{SLSH}$	$C_L = 30 \text{ pF}$	$t_{CYCP} + 10$	-	ns	
Serial clock H pulse width	$t_{SHSL}$		$t_{CYCP} + 10$	-	ns	
SCK falling time	$t_F$		-	5	ns	
SCK rising time	$t_R$		-	5	ns	

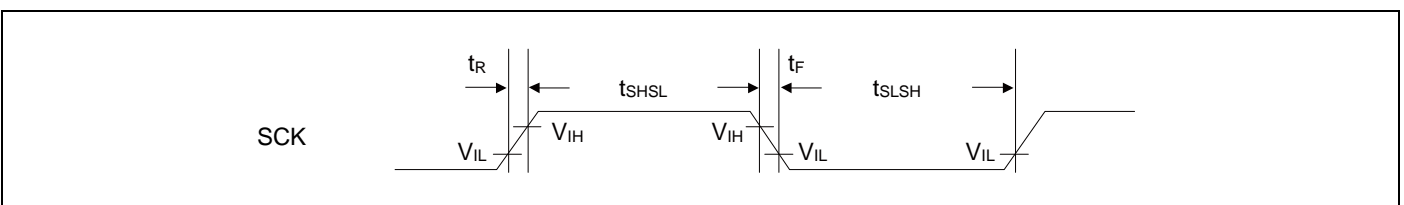

**12.4.10 External Input Timing**

 ( $V_{CC} = 2.7V$  to  $5.5V$ ,  $V_{SS} = 0V$ ,  $T_A = -40^{\circ}C$  to  $+105^{\circ}C$ )

Parameter	Symbol	Pin name	Conditions	Value		Unit	Remarks
				Min	Max		
Input pulse width	$t_{INH}$ , $t_{INL}$	ADTG	-	$2t_{CYCP}^{*1}$	-	ns	A/D converter trigger input
		FRCKx					Free-run timer input clock
		ICxx					Input capture
		DTTlxX	-	$2t_{CYCP}^{*1}$	-	ns	Waveform generator
		INTxx, NMIX	*2	$2t_{CYCP} + 100^{*1}$	-	ns	External interrupt
		WKUPx	*3	500	-	ns	NMI
			*4	500	-	ns	Deep standby wake up

\*1:  $t_{CYCP}$  indicates the APB bus clock cycle time.

About the APB bus number which the A/D converter, Multi-function Timer, External interrupt are connected to, see "Block Diagram" in this data sheet.

\*2: When in Run mode, in Sleep mode.

\*3: When in Stop mode, in RTL mode, in Timer mode.

\*4: When in Deep Standby RTC mode, in Deep Standby Stop mode.

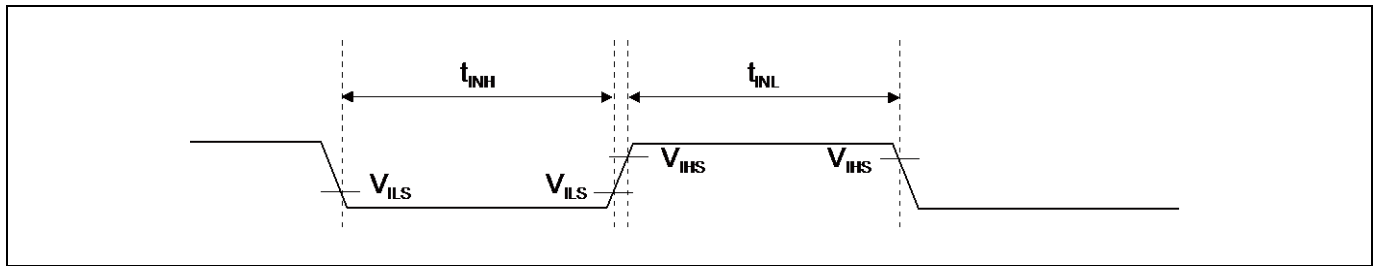

**12.4.11 Quadrature Position/Revolution Counter timing**

 ( $V_{CC} = 2.7V$  to  $5.5V$ ,  $V_{SS} = 0V$ ,  $T_A = -40^{\circ}C$  to  $+105^{\circ}C$ )

Parameter	Symbol	Conditions	Value		Unit
			Min	Max	
AIN pin H width	$t_{AHL}$	-	2 $t_{CYCP}^*$	-	ns
AIN pin L width	$t_{ALL}$	-			
BIN pin H width	$t_{BHL}$	-			
BIN pin L width	$t_{BLL}$	-			
BIN rising time from AIN pin H level	$t_{AUBU}$	PC_Mode2 or PC_Mode3			
AIN falling time from BIN pin H level	$t_{BUAD}$	PC_Mode2 or PC_Mode3			
BIN falling time from AIN pin L level	$t_{ADBD}$	PC_Mode2 or PC_Mode3			
AIN rising time from BIN pin L level	$t_{BDAU}$	PC_Mode2 or PC_Mode3			
AIN rising time from BIN pin H level	$t_{BUAU}$	PC_Mode2 or PC_Mode3			
BIN falling time from AIN pin H level	$t_{AUBD}$	PC_Mode2 or PC_Mode3			
AIN falling time from BIN pin L level	$t_{BDAD}$	PC_Mode2 or PC_Mode3			
BIN rising time from AIN pin L level	$t_{ADBU}$	PC_Mode2 or PC_Mode3			
ZIN pin H width	$t_{ZHL}$	QCR:CGSC=0			
ZIN pin L width	$t_{ZLL}$	QCR:CGSC=0			
AIN/BIN rising and falling time from determined ZIN level	$t_{ZABE}$	QCR:CGSC=1			
Determined ZIN level from AIN/BIN rising and falling time	$t_{ABEZ}$	QCR:CGSC=1			

\*:  $t_{CYCP}$  indicates the APB bus clock cycle time.

About the APB bus number which the Quadrature Position/Revolution Counter is connected to, see “Block Diagram” in this data sheet.

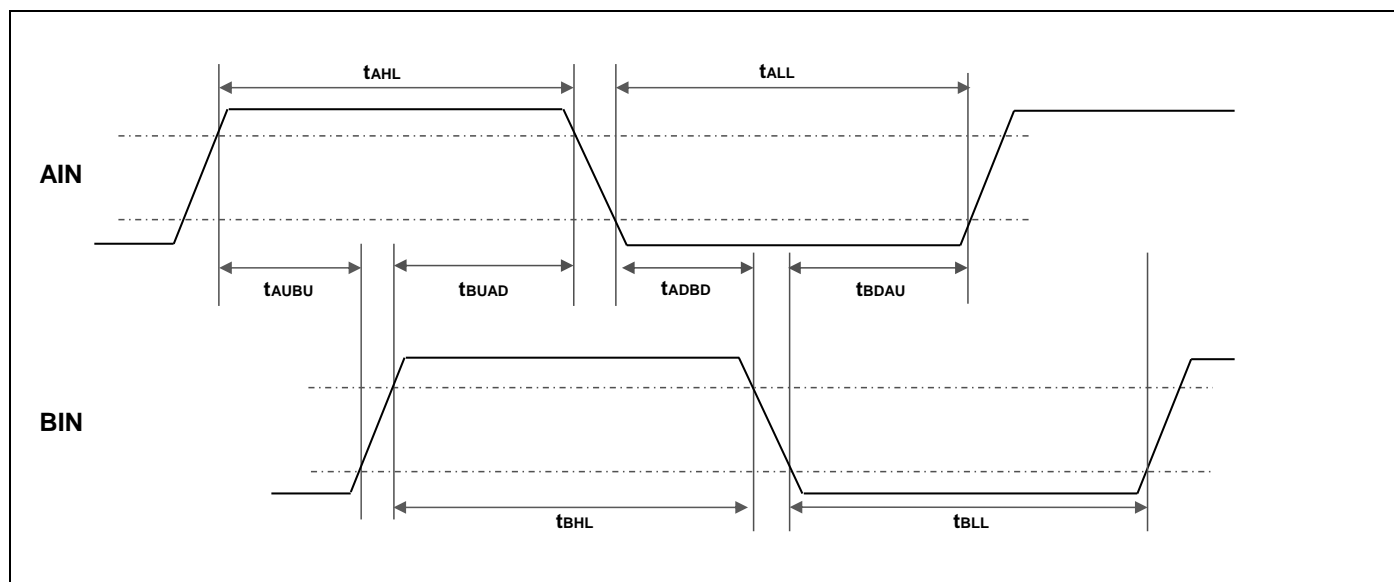

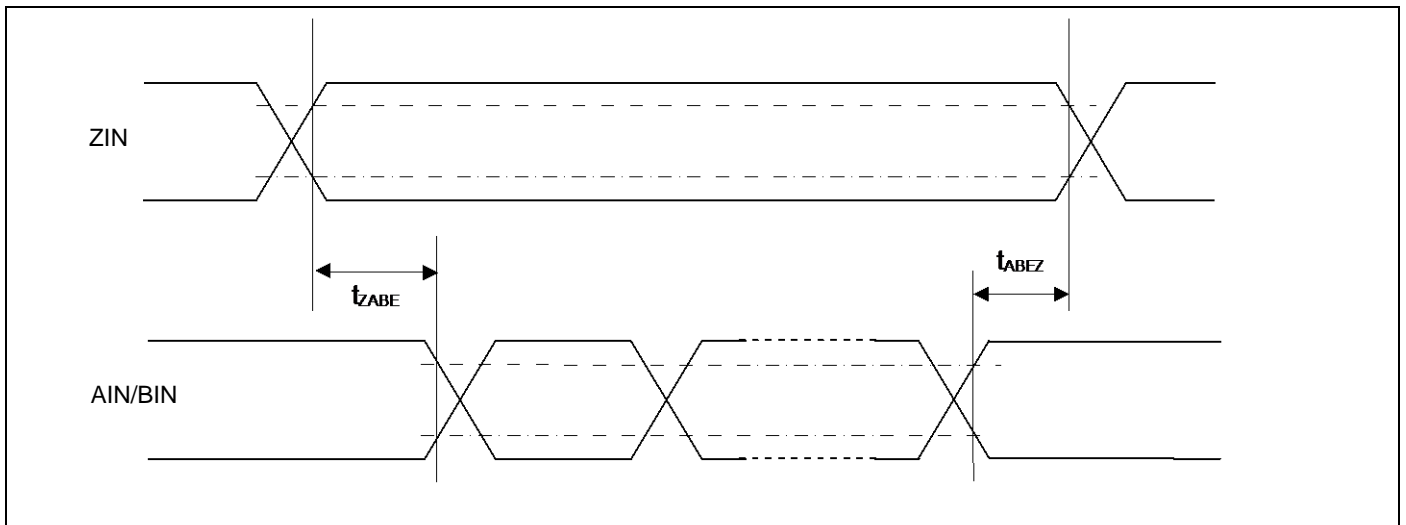
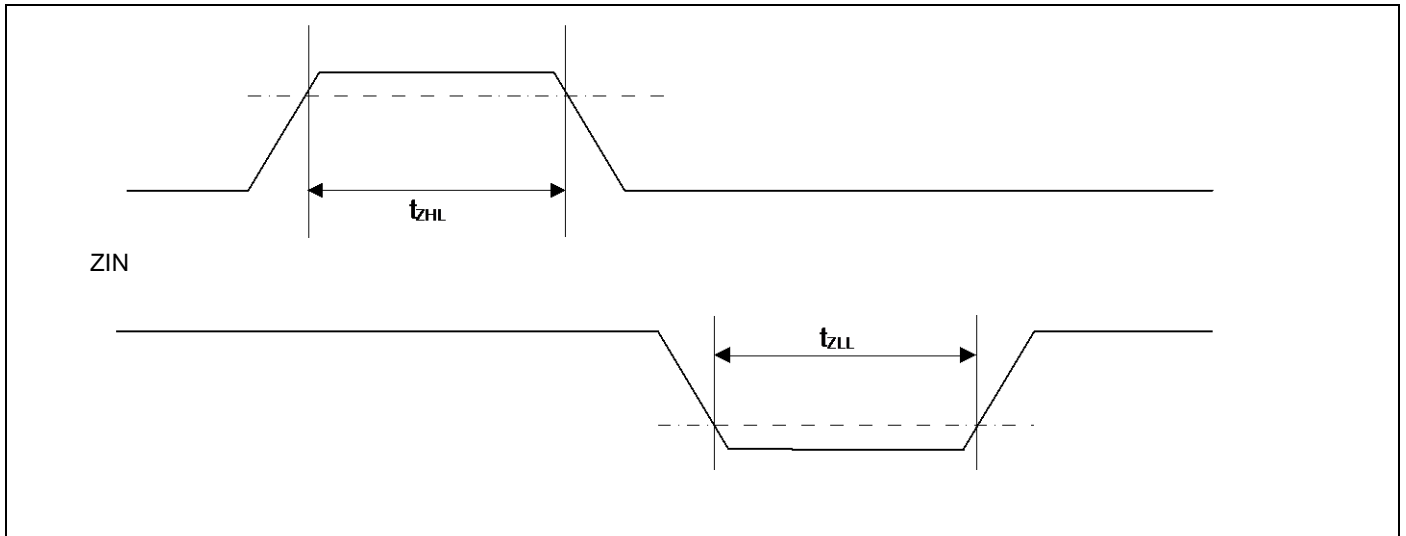
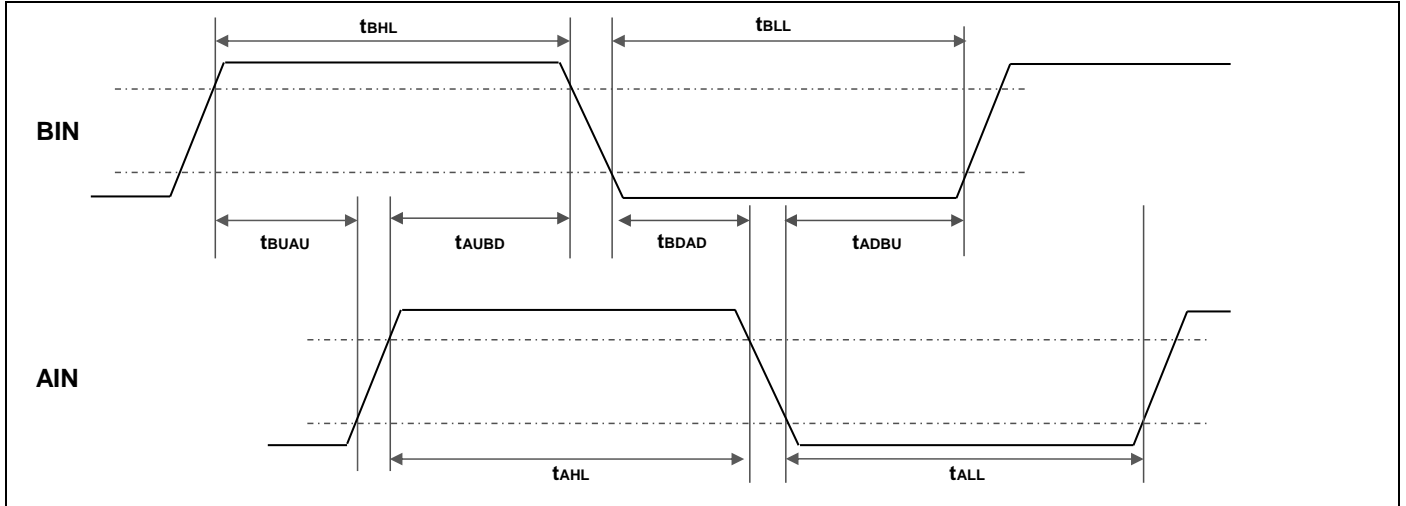

**12.4.12 I<sup>2</sup>C Timing**

 (V<sub>CC</sub> = 2.7V to 5.5V, V<sub>SS</sub> = 0V, T<sub>A</sub> = - 40°C to + 105°C)

Parameter	Symbol	Conditions	Standard-mode		Fast-mode		Unit	Remarks
			Min	Max	Min	Max		
SCL clock frequency	f <sub>SCL</sub>		0	100	0	400	kHz	
(Repeated) START condition hold time SDA ↓ → SCL ↓	t <sub>HDSTA</sub>	C <sub>L</sub> = 30 pF, R = (V <sub>P</sub> /I <sub>OL</sub> )* <sup>1</sup>	4.0	-	0.6	-	μs	
SCL clock L width	t <sub>LOW</sub>		4.7	-	1.3	-	μs	
SCL clock H width	t <sub>HIGH</sub>		4.0	-	0.6	-	μs	
(Repeated) START condition setup time SCL ↑ → SDA ↓	t <sub>SUSTA</sub>		4.7	-	0.6	-	μs	
Data hold time SCL ↓ → SDA ↓ ↑	t <sub>HDDAT</sub>		0	3.45* <sup>2</sup>	0	0.9* <sup>3</sup>	μs	
Data setup time SDA ↓ ↑ → SCL ↑	t <sub>SUDAT</sub>		250	-	100	-	ns	
STOP condition setup time SCL ↑ → SDA ↑	t <sub>SUSTO</sub>		4.0	-	0.6	-	μs	
Bus free time between STOP condition and START condition	t <sub>BUF</sub>		4.7	-	1.3	-	μs	
Noise filter	t <sub>SP</sub>		-	2t <sub>CYCP</sub> * <sup>4</sup>	-	2t <sub>CYCP</sub> * <sup>4</sup>	-	ns

\*1: R and C<sub>L</sub> represent the pull-up resistor and load capacitance of the SCL and SDA lines, respectively.  
V<sub>P</sub> indicates the power supply voltage of the pull-up resistor and I<sub>OL</sub> indicates V<sub>OL</sub> guaranteed current.

\*2: The maximum t<sub>HDDAT</sub> must satisfy that it does not extend at least L period (t<sub>LOW</sub>) of device's SCL signal.

\*3: A Fast mode I<sup>2</sup>C bus device can be used on a Standard mode I<sup>2</sup>C bus system as long as the device satisfies the requirement of "t<sub>SUDAT</sub> ≥ 250 ns".

\*4: t<sub>CYCP</sub> is the APB bus clock cycle time.

About the APB bus number that I<sup>2</sup>C is connected to, see "Block Diagram" in this data sheet.

To use Standard-mode, set the APB bus clock at 2 MHz or more

To use Fast-mode, set the APB bus clock at 8 MHz or more.

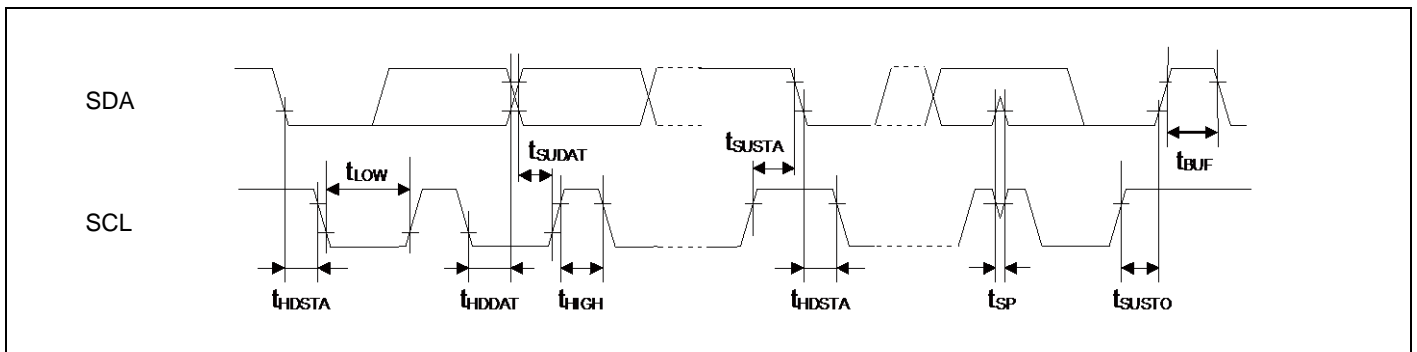

**12.4.13 JTAG Timing**

 ( $V_{CC} = 2.7V$  to  $5.5V$ ,  $V_{SS} = 0V$ ,  $T_A = -40^{\circ}C$  to  $+105^{\circ}C$ )

Parameter	Symbol	Pin name	Conditions	Value		Unit	Remarks
				Min	Max		
TMS, TDI setup time	$t_{JTAGS}$	TCK, TMS, TDI	$V_{CC} \geq 4.5 V$	15	-	ns	
			$V_{CC} < 4.5 V$				
TMS, TDI hold time	$t_{JTAGH}$	TCK, TMS, TDI	$V_{CC} \geq 4.5 V$	15	-	ns	
			$V_{CC} < 4.5 V$				
TDO delay time	$t_{JTAGD}$	TCK, TDO	$V_{CC} \geq 4.5 V$	-	25	ns	
			$V_{CC} < 4.5 V$	-	45		

**Note:**

- When the external load capacitance  $C_L = 30 pF$ .

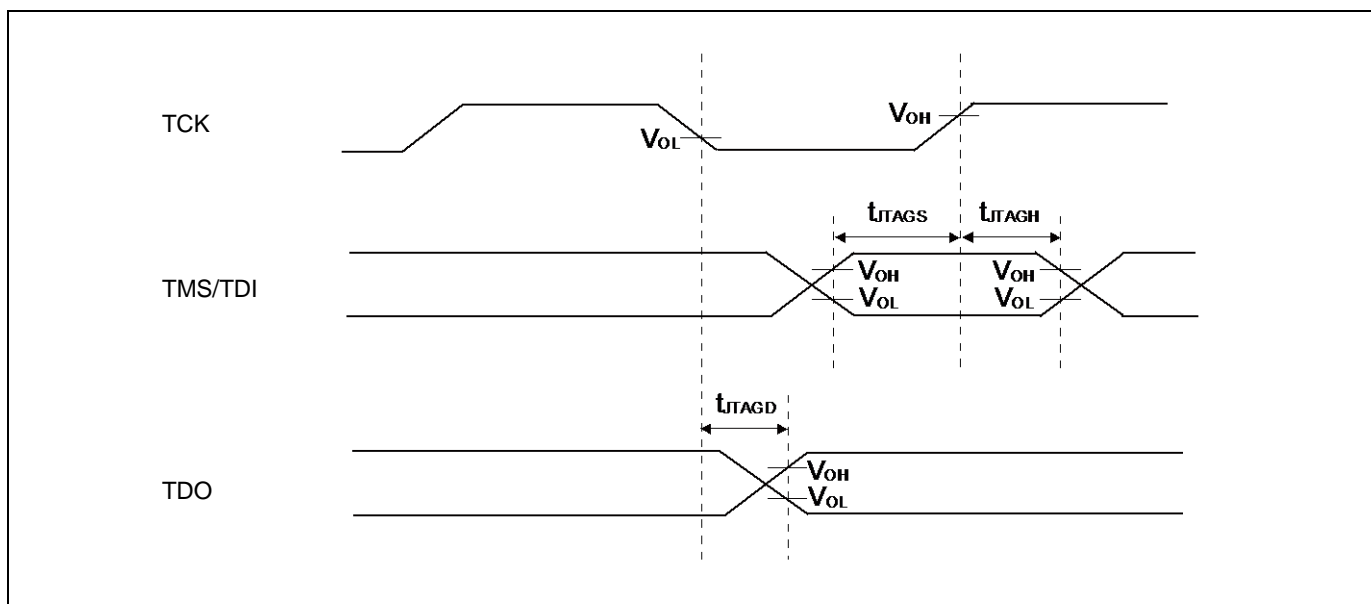

## 12.5 12-bit A/D Converter

### Electrical characteristics for the A/D converter

( $V_{CC} = AV_{CC} = 2.7V$  to  $5.5V$ ,  $V_{SS} = AV_{SS} = AVRL = 0V$ ,  $T_A = -40^{\circ}C$  to  $+105^{\circ}C$ )

Parameter	Symbol	Pin name	Value			Unit	Remarks
			Min	Typ	Max		
Resolution	-	-	-	-	12	bit	
Integral Nonlinearity	-	-	-	$\pm 1.5$	$\pm 4.5$	LSB	AVRH = 2.7 V to 5.5 V
Differential Nonlinearity	-	-	-	$\pm 1.7$	$\pm 2.5$	LSB	
Zero transition voltage	$V_{ZT}$	ANxx	-	$\pm 10$	$\pm 15$	mV	
Full-scale transition voltage	$V_{FST}$	ANxx	-	AVRH $\pm 5$	AVRH $\pm 15$	mV	
Conversion time	-	-	0.8*1	-	-	$\mu s$	AV <sub>CC</sub> $\geq 4.5$ V
			1.0*1	-	-		AV <sub>CC</sub> < 4.5 V
Sampling time*2	$t_s$	-	0.24	-	10	$\mu s$	AV <sub>CC</sub> $\geq 4.5$ V
			0.3	-			AV <sub>CC</sub> < 4.5 V
Compare clock cycle*3	$t_{CCK}$	-	40	-	1000	ns	AV <sub>CC</sub> $\geq 4.5$ V
			50	-			AV <sub>CC</sub> < 4.5 V
State transition time to operation permission	$t_{STT}$	-	-	-	1.0	$\mu s$	
Analog input capacity	$C_{AIN}$	-	-	-	9.7	pF	
Analog input resistor	$R_{AIN}$	-	-	-	1.7	k $\Omega$	AV <sub>CC</sub> $\geq 4.5$ V
					2.4		AV <sub>CC</sub> < 4.5 V
Interchannel disparity	-	-	-	-	4	LSB	
Analog port input leak current	-	ANxx	-	-	5	$\mu A$	
Analog input voltage	-	ANxx	AVRL	-	AVRH	V	
Reference voltage	-	AVRH	2.7	-	AV <sub>CC</sub>	V	
		AVRL	AV <sub>SS</sub>	-	AV <sub>SS</sub>	V	

\*1: The conversion time is the value of sampling time ( $t_s$ ) + compare time ( $t_c$ ).

The condition of the minimum conversion time is the following.

AV<sub>CC</sub>  $\geq 4.5$  V, HCLK=50 MHz sampling time: 240 ns, compare time: 560 ns

AV<sub>CC</sub> < 4.5 V, HCLK=40 MHz sampling time: 300 ns, compare time: 700 ns

Ensure that it satisfies the value of the sampling time ( $t_s$ ) and compare clock cycle ( $t_{CCK}$ ).

For setting of the sampling time and compare clock cycle, see "Chapter 1-1: A/D Converter" in "FM3 Family Peripheral Manual Analog Macro Part".

The register settings of the A/D Converter are reflected in the operation according to the APB bus clock timing.

For the number of the APB bus to which the A/D Converter is connected, see "Block Diagram".

The base clock (HCLK) is used to generate the sampling time and the compare clock cycle.

\*2: A necessary sampling time changes by external impedance.

Ensure that it sets the sampling time to satisfy (Equation 1).

\*3: The compare time ( $t_c$ ) is the value of (Equation 2).

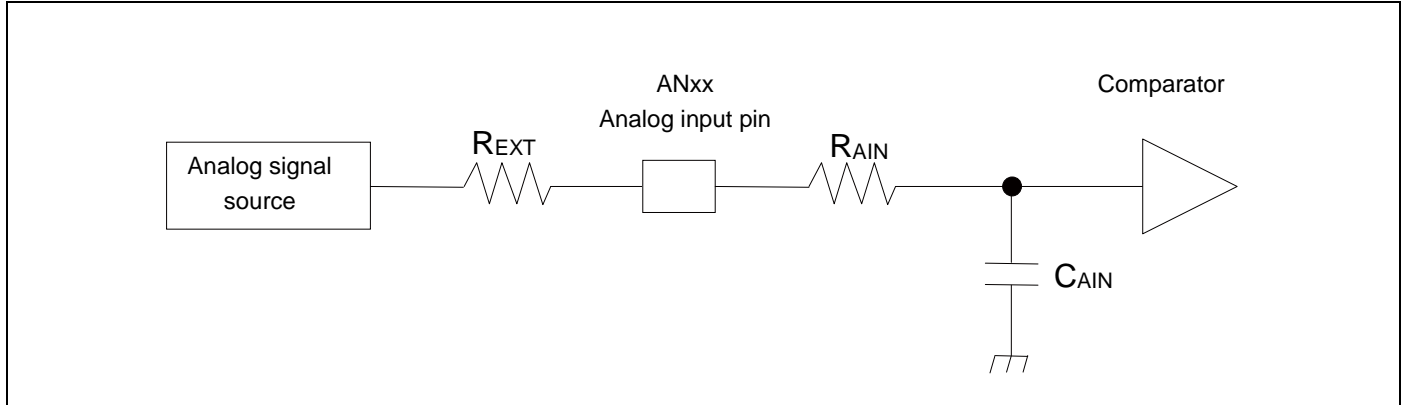

(Equation 1)  $t_s \geq (R_{AIN} + R_{EXT}) \times C_{AIN} \times 9$

$t_s$ : Sampling time

$R_{AIN}$ : Input resistor of A/D = 1.5 k $\Omega$  at 4.5 V  $\leq$  AV<sub>CC</sub>  $\leq$  5.5 V ch.0 to ch.7

Input resistor of A/D = 1.6 k $\Omega$  at 4.5 V  $\leq$  AV<sub>CC</sub>  $\leq$  5.5 V ch.8 to ch.15

Input resistor of A/D = 1.7 k $\Omega$  at 4.5 V  $\leq$  AV<sub>CC</sub>  $\leq$  5.5 V ch.16 to ch.26

Input resistor of A/D = 2.2 k $\Omega$  at 2.7 V  $\leq$  AV<sub>CC</sub> < 4.5 V ch.0 to ch.7

Input resistor of A/D = 2.3 k $\Omega$  at 2.7 V  $\leq$  AV<sub>CC</sub> < 4.5 V ch.8 to ch.15

Input resistor of A/D = 2.4 k $\Omega$  at 2.7 V  $\leq$  AV<sub>CC</sub> < 4.5 V ch.16 to ch.26

$C_{AIN}$ : Input capacity of A/D = 9.7 pF at 2.7 V  $\leq$  AV<sub>CC</sub>  $\leq$  5.5 V

$R_{EXT}$ : Output impedance of external circuit

(Equation 2)  $t_c = t_{CCK} \times 14$

$t_c$ : Compare time

$t_{CCK}$ : Compare clock cycle



**12.6 10-bit D/A Converter**
**Electrical Characteristics for the D/A Converter**

 (V<sub>CC</sub> = AV<sub>CC</sub> = 2.7V to 5.5V, V<sub>SS</sub> = AV<sub>SS</sub> = AV<sub>RL</sub> = 0V, T<sub>A</sub> = - 40°C to + 105°C)

Parameter	Symbol	Pin name	Value			Unit	Remarks
			Min	Typ	Max		
Resolution	-	DAx	-	-	10	bit	
Conversion time	t <sub>C20</sub>		0.47	0.58	0.69	μs	Load 20 pF
	t <sub>C100</sub>		2.37	2.90	3.43	μs	Load 100 pF
Integral Nonlinearity*1	INL		- 4.0	-	+ 4.0	LSB	
Differential Nonlinearity*1,*2	DNL		- 0.9	-	+ 0.9	LSB	
Output Voltage offset	V <sub>OFF</sub>		-	-	10.0	mV	Code is 0x000
			- 20.0	-	+ 5.4	mV	Code is 0x3FF
Analog output impedance	R <sub>O</sub>		3.10	3.80	4.50	kΩ	D/A operation
			2.0	-	-	MΩ	D/A stop
Output undefined period	t <sub>R</sub>		-	-	70	ns	

\*1: No-load

\*2: Generates the max current by the CODE about 0x200

12.7 USB Characteristics

(V<sub>CC</sub> = 2.7V to 5.5V, USBV<sub>CC</sub> = 3.0V to 3.6V, V<sub>SS</sub> = 0V, T<sub>A</sub> = - 40°C to + 105°C)

Parameter	Symbol	Pin name	Conditions	Value		Unit	Remarks
				Min	Max		
Input characteristics	Input H level voltage	V <sub>IH</sub>	-	2.0	USBV <sub>CC</sub> + 0.3	V	*1
	Input L level voltage	V <sub>IL</sub>		V <sub>SS</sub> - 0.3	0.8	V	*1
	Differential input sensitivity	V <sub>DI</sub>		0.2	-	V	*2
	Different common mode range	V <sub>CM</sub>		0.8	2.5	V	*2
Output characteristics	Output H level voltage	V <sub>OH</sub>	External pull-down resistor = 15 kΩ	2.8	3.6	V	*3
	Output L level voltage	V <sub>OL</sub>		External pull-up resistor = 1.5 kΩ	0.0	0.3	V
	Crossover voltage	V <sub>CRS</sub>	-		1.3	2.0	V
	Rising time	t <sub>FR</sub>	Full-Speed	4	20	ns	*5
	Falling time	t <sub>FF</sub>	Full-Speed	4	20	ns	*5
	Rising/falling time matching	t <sub>FRFM</sub>	Full-Speed	90	111.11	%	*5
	Output impedance	Z <sub>DRV</sub>	Full-Speed	28	44	Ω	*6
	Rising time	t <sub>LR</sub>	Low-Speed	75	300	ns	*7
	Falling time	t <sub>LF</sub>	Low-Speed	75	300	ns	*7
	Rising/falling time matching	t <sub>LRFM</sub>	Low-Speed	80	125	%	*7

\*1: The switching threshold voltage of the Single-End-Receiver of USB I/O buffer is set as within V<sub>IL</sub> (Max) = 0.8V, V<sub>IH</sub> (Min) = 2.0 V (TTL input standard). There are some hysteresis to lower noise sensitivity.

\*2: Use the differential-Receiver to receive the USB differential data signal. The Differential-Receiver has 200 mV of differential input sensitivity when the differential data input is within 0.8 V to 2.5 V to the local ground reference level. The voltage range above is said to be the common mode input voltage range.

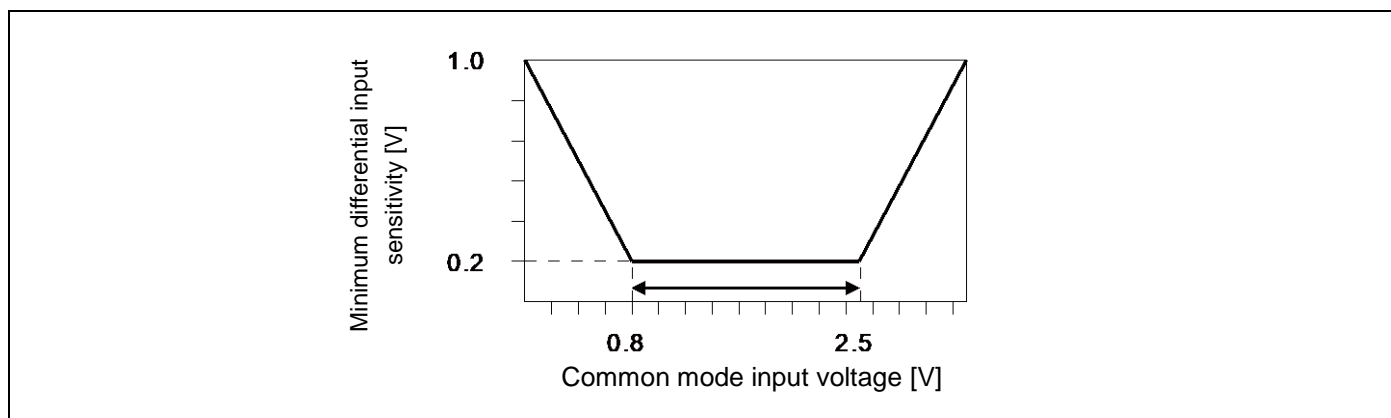

\*3: The output drive capability of the driver is below 0.3 V at Low-State ( $V_{OL}$ ) (to 3.6 V and 1.5 k $\Omega$  load), and 2.8 V or above (to ground and 15 k $\Omega$  load) at High-State ( $V_{OH}$ ).

\*4: The cross voltage of the external differential output signal (D + /D - ) of USB I/O buffer is within 1.3 V to 2.0 V.

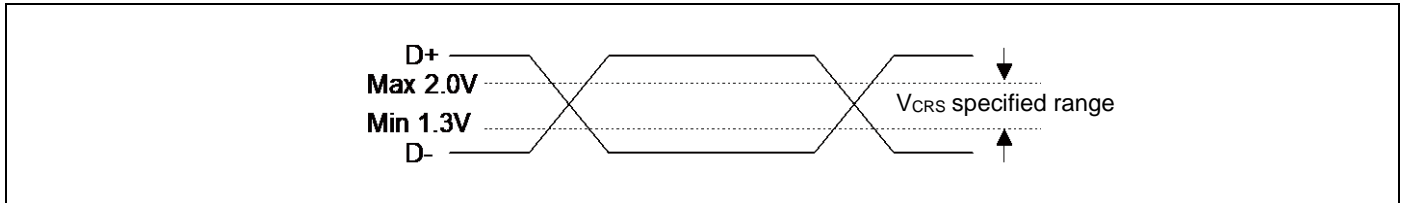

\*5: They indicate rising time ( $T_{rise}$ ) and falling time ( $T_{fall}$ ) of the full-speed differential data signal. They are defined by the time between 10% and 90% of the output signal voltage. For full-speed buffer,  $T_r/T_f$  ratio is regulated as within  $\pm 10\%$  to minimize RFI emission.

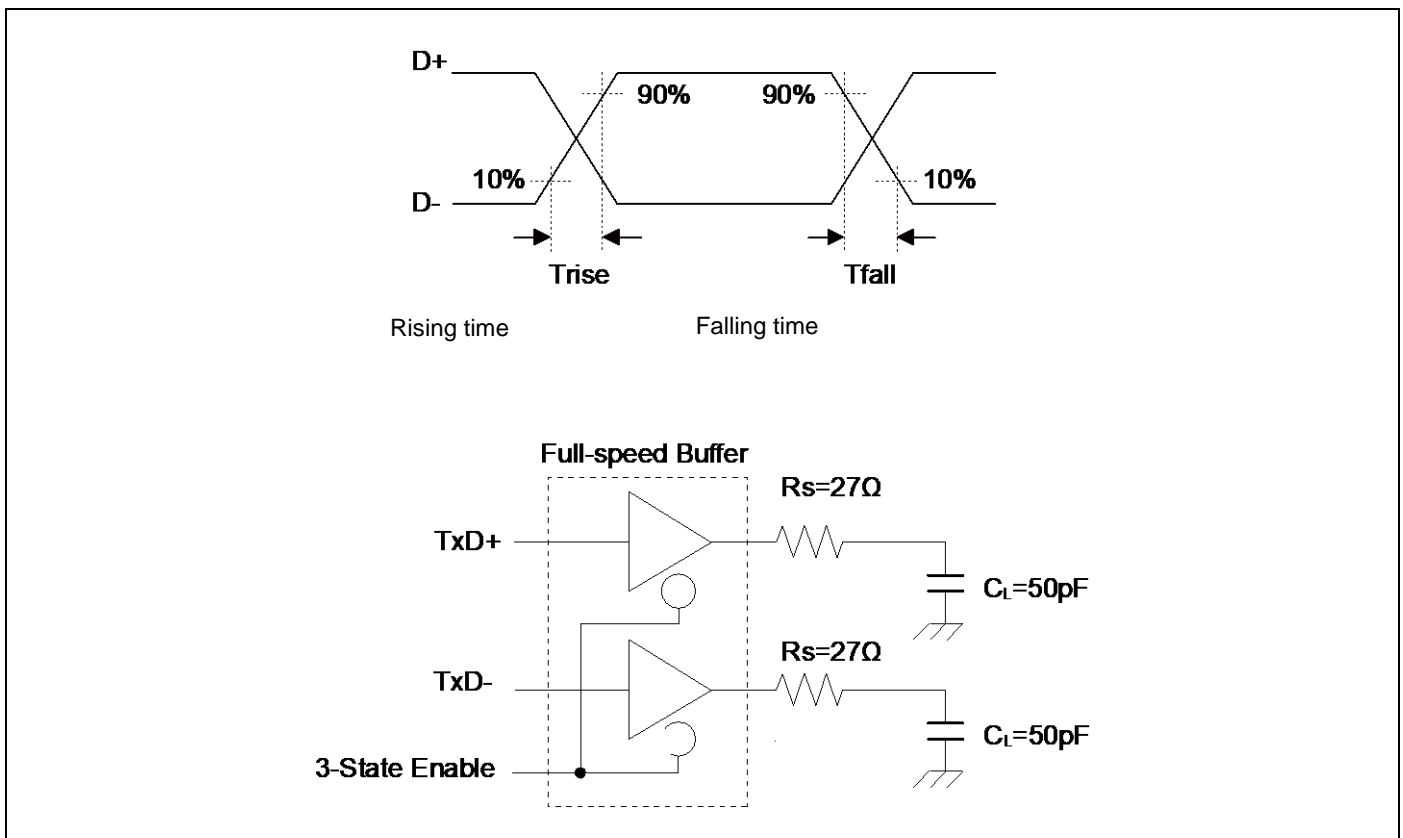

\*6: USB Full-speed connection is performed via twist pair cable shield with  $90\ \Omega \pm 15\%$  characteristic impedance (Differential Mode).

USB standard defines that output impedance of USB driver must be in range from  $28\ \Omega$  to  $44\ \Omega$ . So, discrete series resistor ( $R_s$ ) addition is defined in order to satisfy the above definition and keep balance.

When using this USB I/O, use it with  $25\ \Omega$  to  $30\ \Omega$  (recommendation value  $27\ \Omega$ ) Series resistor  $R_s$ .

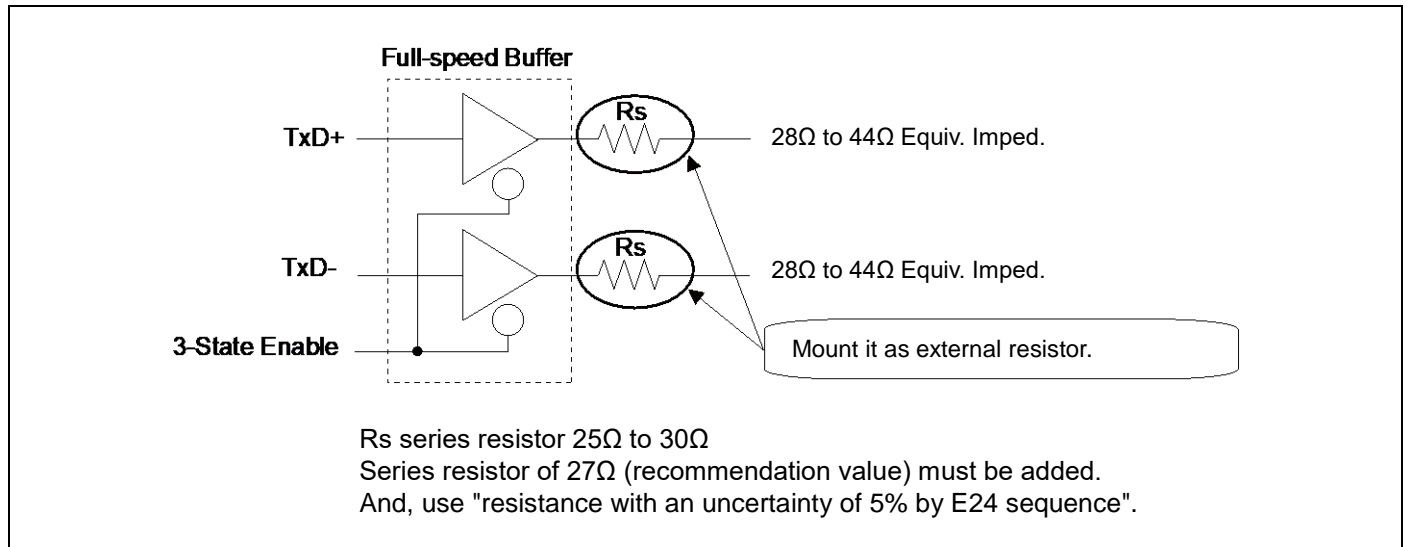

\*7: They indicate rising time ( $T_{rise}$ ) and falling time ( $T_{fall}$ ) of the low-speed differential data signal. They are defined by the time between 10% and 90% of the output signal voltage.

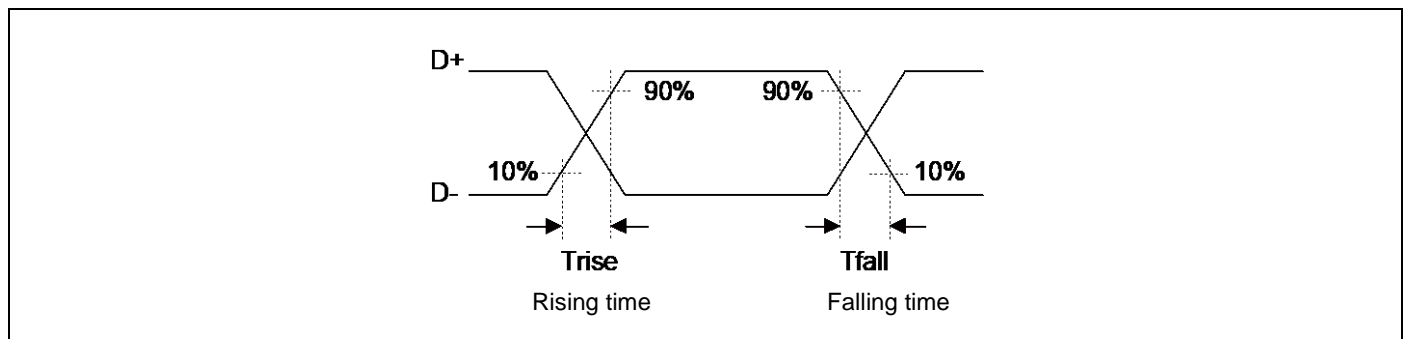

See "Low-Speed Load (Compliance Load)" for conditions of the external load.

Low-Speed Load (Upstream Port Load) - Reference 1

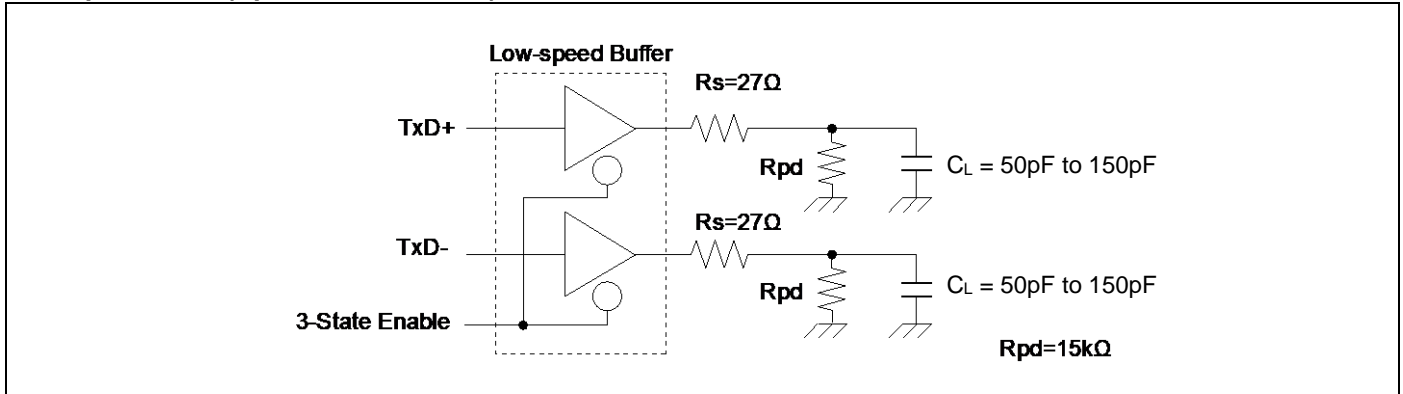

Low-Speed Load (Downstream Port Load) - Reference 2

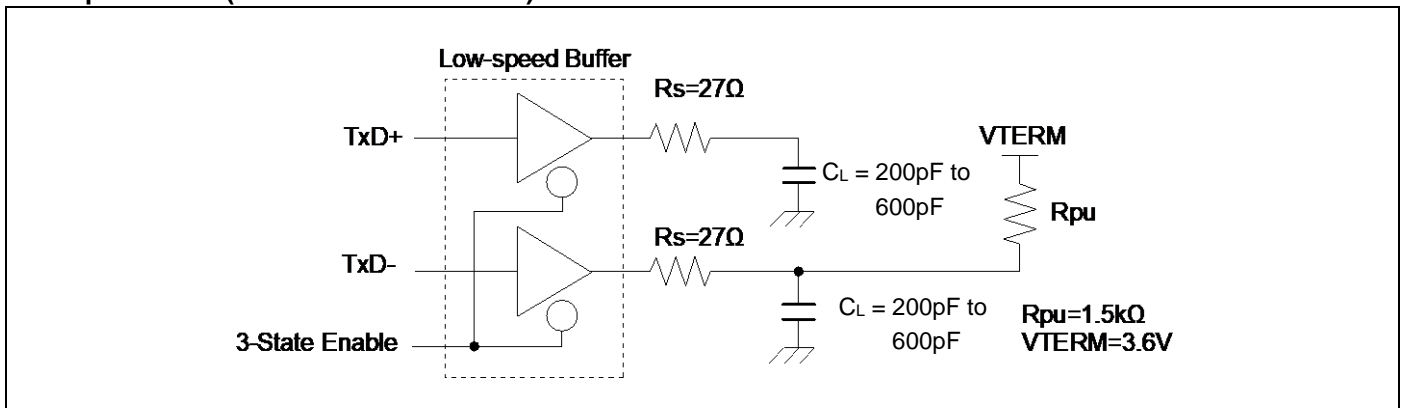

Low-Speed Load (Compliance Load)

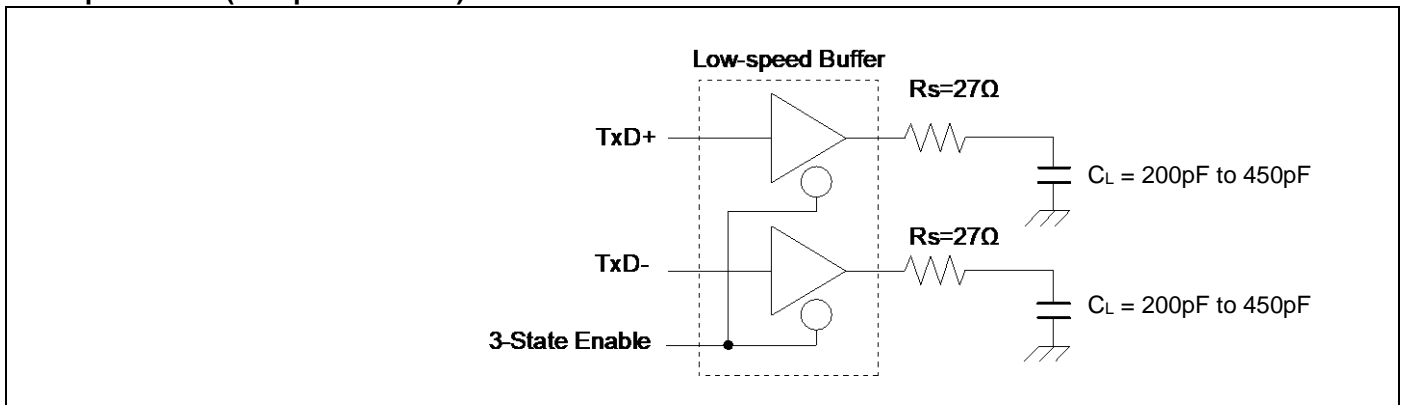

## 12.8 Low-Voltage Detection Characteristics

### 12.8.1 Low-Voltage Detection Reset

 (T<sub>A</sub> = - 40°C to + 105°C)

Parameter	Symbol	Conditions	Value			Unit	Remarks
			Min	Typ	Max		
Detected voltage	VDL	SVHR*1=	2.25	2.45	2.65	V	When voltage drops
Released voltage	VDH	00000	2.30	2.50	2.70	V	When voltage rises
Detected voltage	VDL	SVHR*1=	2.39	2.60	2.81	V	When voltage drops
Released voltage	VDH	00001	Same as SVHR = 00000 value			V	When voltage rises
Detected voltage	VDL	SVHR*1=	2.48	2.70	2.92	V	When voltage drops
Released voltage	VDH	00010	Same as SVHR = 00000 value			V	When voltage rises
Detected voltage	VDL	SVHR*1=	2.58	2.80	3.02	V	When voltage drops
Released voltage	VDH	00011	Same as SVHR = 00000 value			V	When voltage rises
Detected voltage	VDL	SVHR*1=	2.76	3.00	3.24	V	When voltage drops
Released voltage	VDH	00100	Same as SVHR = 00000 value			V	When voltage rises
Detected voltage	VDL	SVHR*1=	2.94	3.20	3.46	V	When voltage drops
Released voltage	VDH	00101	Same as SVHR = 00000 value			V	When voltage rises
Detected voltage	VDL	SVHR*1=	3.31	3.60	3.89	V	When voltage drops
Released voltage	VDH	00110	Same as SVHR = 00000 value			V	When voltage rises
Detected voltage	VDL	SVHR*1=	3.40	3.70	4.00	V	When voltage drops
Released voltage	VDH	00111	Same as SVHR = 00000 value			V	When voltage rises
Detected voltage	VDL	SVHR*1=	3.68	4.00	4.32	V	When voltage drops
Released voltage	VDH	01000	Same as SVHR = 00000 value			V	When voltage rises
Detected voltage	VDL	SVHR*1=	3.77	4.10	4.43	V	When voltage drops
Released voltage	VDH	01001	Same as SVHR = 00000 value			V	When voltage rises
Detected voltage	VDL	SVHR*1=	3.86	4.20	4.54	V	When voltage drops
Released voltage	VDH	01010	Same as SVHR = 00000 value			V	When voltage rises
LVD stabilization wait time	t <sub>LVDW</sub>	-	-	-	8160 × t <sub>CYCP</sub> *2	μs	
LVD detection delay time	t <sub>LVDL</sub>	-	-	-	200	μs	

\*1: The SVHR bit of Low-Voltage Detection Voltage Control Register (LVD\_CTL) is initialized to "00000" by Low-Voltage Detection Reset.

\*2: t<sub>CYCP</sub> indicates the APB2 bus clock cycle time.

**12.8.2 Interrupt of Low-Voltage Detection**

 (T<sub>A</sub> = - 40°C to + 105°C)

Parameter	Symbol	Conditions	Value			Unit	Remarks
			Min	Typ	Max		
Detected voltage	VDL	SVHI = 00011	2.58	2.80	3.02	V	When voltage drops
Released voltage	VDH		2.67	2.90	3.13	V	When voltage rises
Detected voltage	VDL	SVHI = 00100	2.76	3.00	3.24	V	When voltage drops
Released voltage	VDH		2.85	3.10	3.35	V	When voltage rises
Detected voltage	VDL	SVHI = 00101	2.94	3.20	3.46	V	When voltage drops
Released voltage	VDH		3.04	3.30	3.56	V	When voltage rises
Detected voltage	VDL	SVHI = 00110	3.31	3.60	3.89	V	When voltage drops
Released voltage	VDH		3.40	3.70	4.00	V	When voltage rises
Detected voltage	VDL	SVHI = 00111	3.40	3.70	4.00	V	When voltage drops
Released voltage	VDH		3.50	3.80	4.10	V	When voltage rises
Detected voltage	VDL	SVHI = 01000	3.68	4.00	4.32	V	When voltage drops
Released voltage	VDH		3.77	4.10	4.43	V	When voltage rises
Detected voltage	VDL	SVHI = 01001	3.77	4.10	4.43	V	When voltage drops
Released voltage	VDH		3.86	4.20	4.54	V	When voltage rises
Detected voltage	VDL	SVHI = 01010	3.86	4.20	4.54	V	When voltage drops
Released voltage	VDH		3.96	4.30	4.64	V	When voltage rises
LVD stabilization wait time	t <sub>LVDW</sub>	-	-	-	8160 × t <sub>CYCP</sub>	μs	
LVD detection delay time	t <sub>LVDL</sub>	-	-	-	200	μs	

 \*: t<sub>CYCP</sub> indicates the APB2 bus clock cycle time.

## 12.9 Flash Memory Write/Erase Characteristics

### 12.9.1 Write / Erase time

(V<sub>CC</sub> = 2.7V to 5.5V, T<sub>A</sub> = - 40°C to + 105°C)

Parameter		Value		Unit	Remarks
		Typ	Max		
Sector erase time	Large Sector	1.1	2.7	s	Includes write time prior to internal erase
	Small Sector	0.3	0.9		
Half word (16-bit) write time		16	310	μs	Not including system-level overhead time
Chip erase time		6.8	18	s	Includes write time prior to internal erase

\*: The typical value is immediately after shipment, the maximum value is guarantee value under 10,000 cycle of erase/write.

### 12.9.2 Write cycles and data hold time

Erase/write cycles (cycle)	Data hold time (year)	Remarks
1,000	20*	
10,000	10*	

\*: At average + 85°C

## 12.10 Return Time from Low-Power Consumption Mode

### 12.10.1 Return Factor: Interrupt/WKUP

The return time from Low-Power consumption mode is indicated as follows. It is from receiving the return factor to starting the program operation.

#### Return Count Time

( $V_{CC} = 2.7V$  to  $5.5V$ ,  $T_A = -40^{\circ}C$  to  $+105^{\circ}C$ )

Parameter	Symbol	Value		Unit	Remarks
		Typ	Max*		
Sleep mode	$t_{ICNT}$	$t_{CYCC}$		$\mu s$	
High-speed CR Timer mode, Main Timer mode, PLL Timer mode		40	80	$\mu s$	
Low-speed CR Timer mode		340	680	$\mu s$	
Sub Timer mode		680	860	$\mu s$	
RTC mode, Stop mode		268	503	$\mu s$	
Deep Standby RTC mode		308	583	$\mu s$	When RAM is off
Deep Standby Stop mode		268	503	$\mu s$	When RAM is on

\*: The maximum value depends on the accuracy of built-in CR.

#### Operation example of return from Low-Power consumption mode (by external interrupt\*)

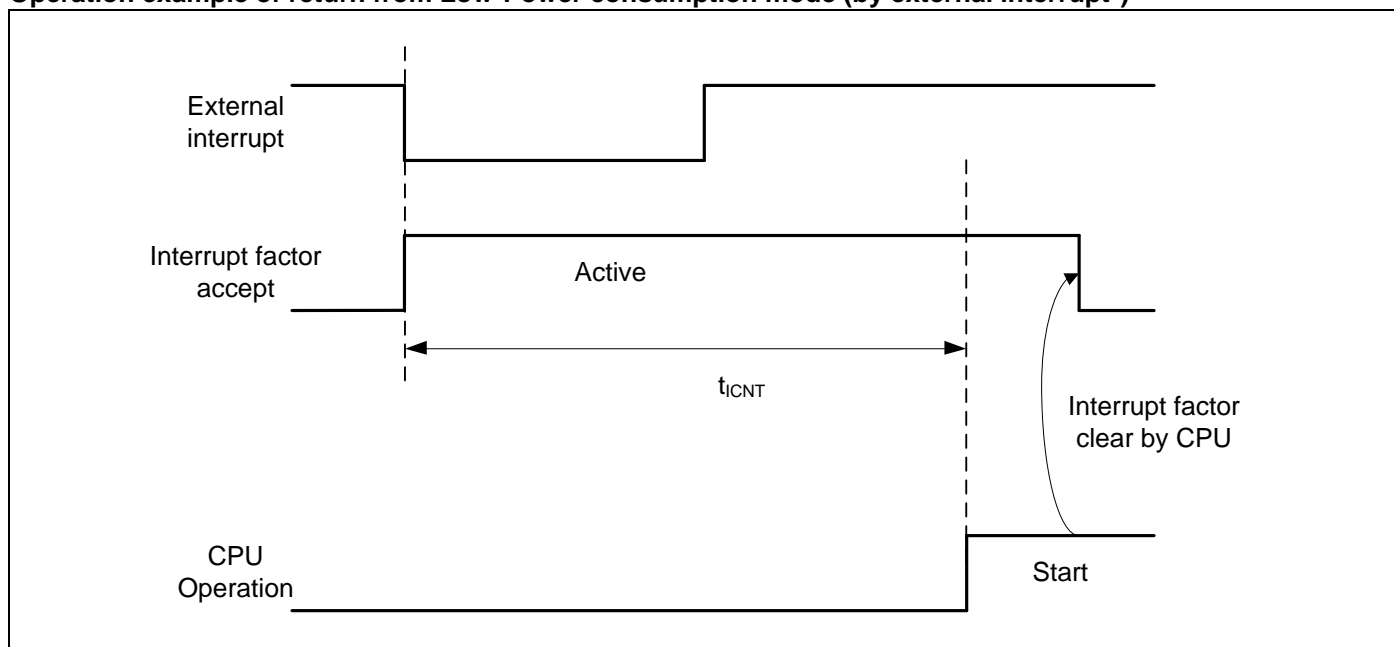

\*: External interrupt is set to detecting fall edge.

Operation example of return from Low-Power consumption mode (by internal resource interrupt\*)

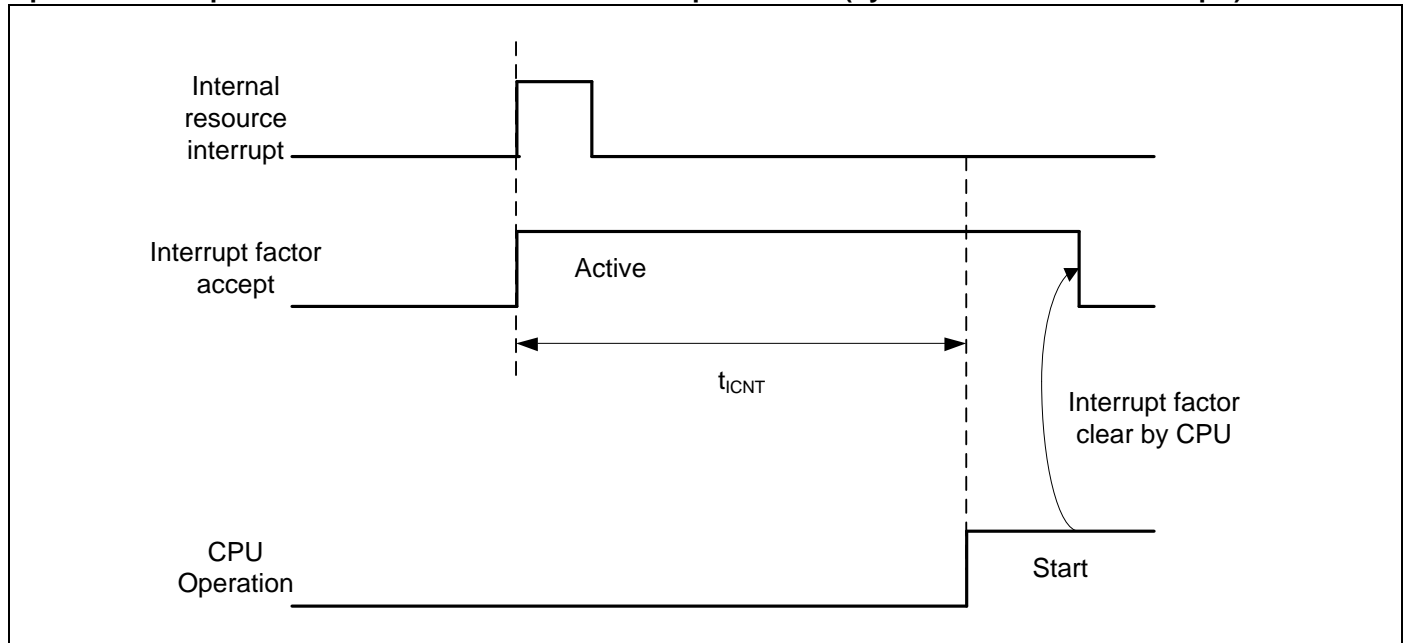

\*: Internal resource interrupt is not included in return factor by the kind of Low-Power consumption mode.

**Notes:**

- The return factor is different in each Low-Power consumption modes.
- See "Chapter 6: Low Power Consumption Mode" and "Operations of Standby Modes" in FM3 Family Peripheral Manual.
- When interrupt recovers, the operation mode that CPU recovers depends on the state before the Low-Power consumption mode transition. See "Chapter 6: Low Power Consumption Mode" in "FM3 Family Peripheral Manual".

### 12.10.2 Return Factor: Reset

The return time from Low-Power consumption mode is indicated as follows. It is from releasing reset to starting the program operation.

#### Return Count Time

( $V_{CC} = 2.7V$  to  $5.5V$ ,  $T_A = -40^{\circ}C$  to  $+105^{\circ}C$ )

Parameter	Symbol	Value		Unit	Remarks
		Typ	Max*		
Sleep mode	$t_{RCNT}$	148	263	$\mu s$	
High-speed CR Timer mode, Main Timer mode, PLL Timer mode		148	263	$\mu s$	
Low-speed CR Timer mode		248	463	$\mu s$	
Sub Timer mode		312	496	$\mu s$	
RTC mode, Stop mode		268	503	$\mu s$	
Deep Standby RTC mode		308	583	$\mu s$	When RAM is off
Deep Standby Stop mode		268	503	$\mu s$	When RAM is on

\*: The maximum value depends on the accuracy of built-in CR.

#### Operation example of return from Low-Power consumption mode (by INITX)

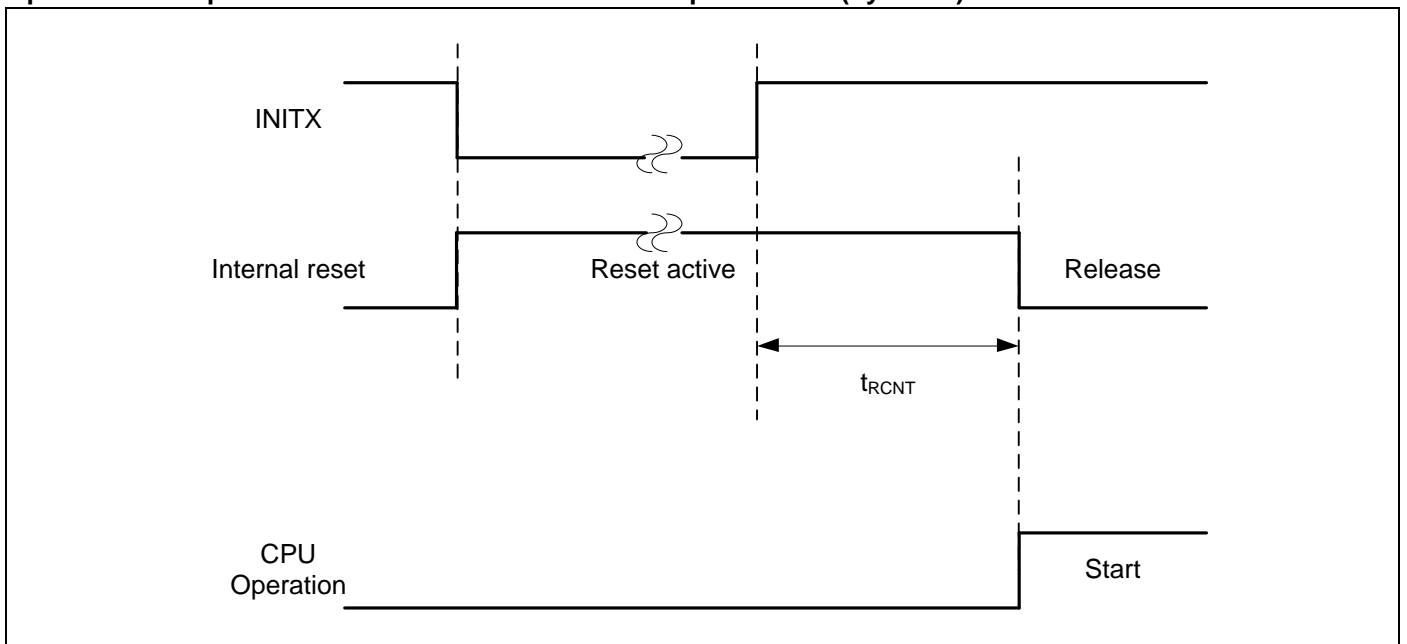

Operation example of return from low power consumption mode (by internal resource reset\*)

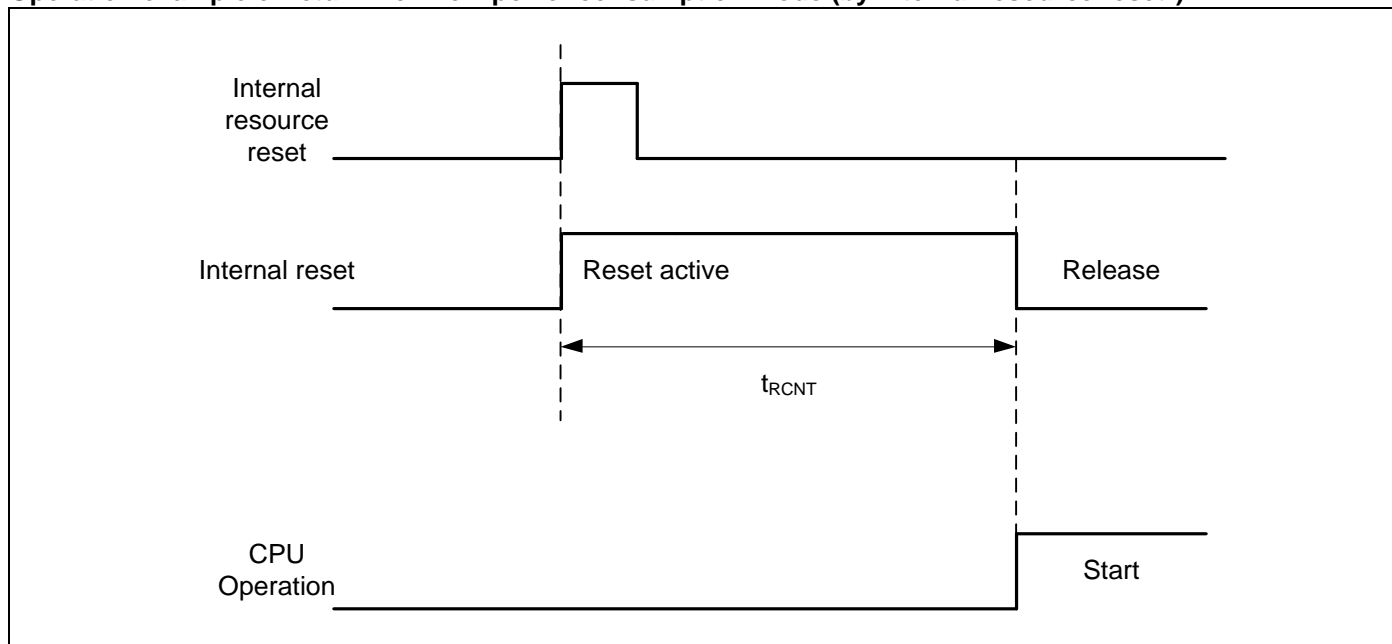

\*: Internal resource reset is not included in return factor by the kind of Low-Power consumption mode.

**Notes:**

- The return factor is different in each Low-Power consumption modes.
- See "Chapter 6: Low Power Consumption Mode" and "Operations of Standby Modes" in FM3 Family Peripheral Manual.
- When interrupt recovers, the operation mode that CPU recovers depends on the state before the Low-Power consumption mode transition. See "Chapter 6: Low Power Consumption Mode" in "FM3 Family Peripheral Manual".
- The time during the power-on reset/low-voltage detection reset is excluded. See "12.4.7. Power-on Reset Timing in 12.4. AC Characteristics in 12. Electrical Characteristics" for the detail on the time during the power-on reset/low-voltage detection reset.
- When in recovery from reset, CPU changes to the high-speed CR run mode. When using the main clock or the PLL clock, it is necessary to add the main clock oscillation stabilization wait time or the Main PLL clock stabilization wait time.
- The internal resource reset means the watchdog reset and the CSV reset.

### 13. Ordering Information

Part number	On-chip Flash memory	On-chip SRAM	Package	Packing
CY9BF521MBGL-GK9E1	Main: 64 Kbyte Work: 32 Kbyte	16 Kbyte	Plastic • PFBGA (0.5 mm pitch), 96-pin (BGA-96P-M07)	Tray
CY9BF522MBGL-GK9E1	Main: 128 Kbyte Work: 32 Kbyte	16 Kbyte		
CY9BF524MBGL-GK9E1	Main: 256 Kbyte Work: 32 Kbyte	32 Kbyte		
CY9BF521KPMC-G-MNE2	Main: 64 Kbyte Work: 32 Kbyte	16 Kbyte	Plastic • LQFP (0.5 mm pitch), 48-pin (LQA048)	
CY9BF522KPMC-G-MNE2	Main: 128 Kbyte Work: 32 Kbyte	16 Kbyte		
CY9BF524KPMC-G-MNE2	Main: 256 Kbyte Work: 32 Kbyte	32 Kbyte		
CY9BF521LPMC1-G-MNE2	Main: 64 Kbyte Work: 32 Kbyte	16 Kbyte	Plastic • LQFP (0.5 mm pitch), 64-pin (LQD064)	
CY9BF522LPMC1-G-MNE2	Main: 128 Kbyte Work: 32 Kbyte	16 Kbyte		
CY9BF524LPMC1-G-MNE2	Main: 256 Kbyte Work: 32 Kbyte	32 Kbyte		
CY9BF521LPMC-G-MNE2	Main: 64 Kbyte Work: 32 Kbyte	16 Kbyte	Plastic • LQFP (0.65 mm pitch), 64-pin (LQG064)	
CY9BF522LPMC-G-MNE2	Main: 128 Kbyte Work: 32 Kbyte	16 Kbyte		
CY9BF524LPMC-G-MNE2	Main: 256 Kbyte Work: 32 Kbyte	32 Kbyte		
CY9BF521MPMC-G-MNE2	Main: 64 Kbyte Work: 32 Kbyte	16 Kbyte	Plastic • LQFP (0.5 mm pitch), 80-pin (LQH080)	
CY9BF522MPMC-G-MNE2	Main: 128 Kbyte Work: 32 Kbyte	16 Kbyte		
CY9BF524MPMC-G-MNE2	Main: 256 Kbyte Work: 32 Kbyte	32 Kbyte		

### 14. Package Dimensions

Package Type	Package Code
LQFP 80	LQH080

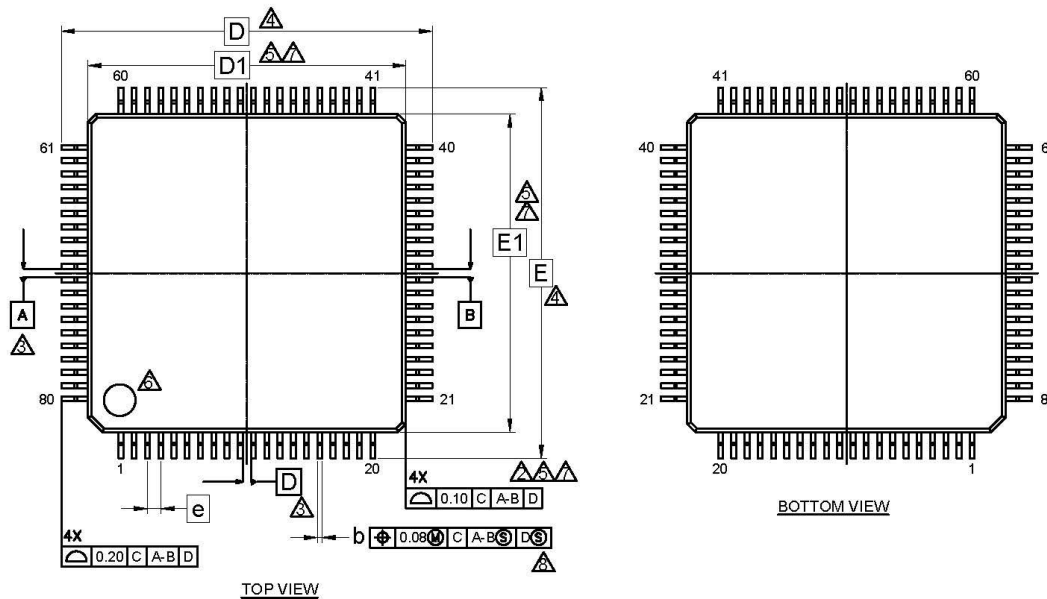

BOTTOM VIEW

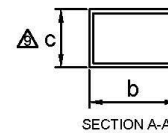
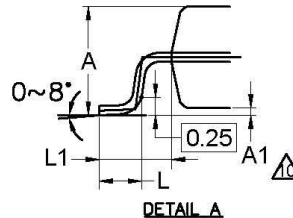
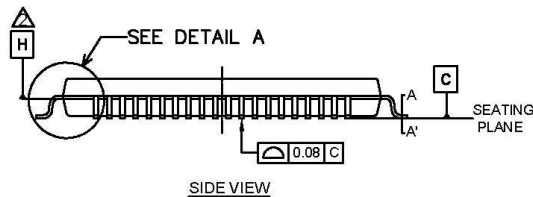

SYMBOL	DIMENSIONS		
	MIN.	NOM.	MAX.
A	—	—	1.70
A1	0.05	—	0.15
b	0.15	—	0.27
c	0.09	—	0.20
D	14.00 BSC.		
D1	12.00 BSC.		
e	0.50 BSC.		
E	14.00 BSC.		
E1	12.00 BSC.		
L	0.45	0.60	0.75
L1	1.00 REF		

**NOTES**

- CONTROLLING DIMENSIONS ARE IN MILLIMETERS (mm)
- DATUM PLANE H IS LOCATED AT THE BOTTOM OF THE MOLD PARTING LINE COINCIDENT WITH WHERE THE LEAD EXITS THE BODY.
- DATUMS A-B AND D TO BE DETERMINED AT DATUM PLANE H.
- TO BE DETERMINED AT SEATING PLANE C.
- DIMENSIONS D1 AND E1 DO NOT INCLUDE MOLD PROTRUSION. ALLOWABLE PROTRUSION IS 0.25mm PRE SIDE. DIMENSIONS D1 AND E1 INCLUDE MOLD MISMATCH AND ARE DETERMINED AT DATUM PLANE H.
- DETAILS OF PIN 1 IDENTIFIER ARE OPTIONAL BUT MUST BE LOCATED WITHIN THE ZONE INDICATED.
- REGARDLESS OF THE RELATIVE SIZE OF THE UPPER AND LOWER BODY SECTIONS, DIMENSIONS D1 AND E1 ARE DETERMINED AT THE LARGEST FEATURE OF THE BODY EXCLUSIVE OF MOLD FLASH AND GATE BURRS, BUT INCLUDING ANY MISMATCH BETWEEN THE UPPER AND LOWER SECTIONS OF THE MOLDER BODY.
- DIMENSION b DOES NOT INCLUDE DAMBAR PROTRUSION. THE DAMBAR PROTRUSION(S) SHALL NOT CAUSE THE LEAD WIDTH TO EXCEED b MAXIMUM BY MORE THAN 0.08mm. DAMBAR CANNOT BE LOCATED ON THE LOWER RADIUS OR THE LEAD FOOT.
- THESE DIMENSIONS APPLY TO THE FLAT SECTION OF THE LEAD BETWEEN 0.10mm AND 0.25mm FROM THE LEAD TIP.
- A1 IS DEFINED AS THE DISTANCE FROM THE SEATING PLANE TO THE LOWEST POINT OF THE PACKAGE BODY.

002-11501 \*A

<b>Package Type</b>	<b>Package Code</b>
LQFP 80	LQJ080

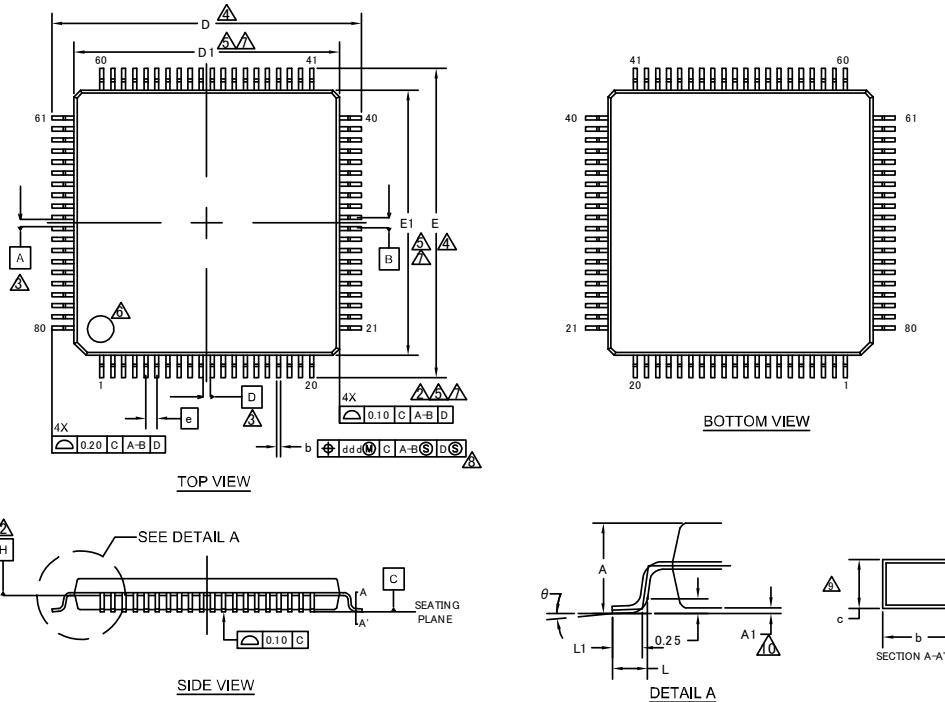

SYMBOL	DIMENSIONS		
	MIN.	NOM.	MAX.
A	—	—	1.70
A1	0.00	—	0.20
b	0.16	0.32	0.38
c	0.09	—	0.20
D	16.00 BSC		
D1	14.00 BSC		
e	0.65 BSC		
E	16.00 BSC		
E1	14.00 BSC		
L	0.45	0.60	0.75
L1	0.30	0.50	0.70
$\theta$	0°	—	8°

### NOTES

- ALL DIMENSIONS ARE IN MILLIMETERS.
- DATUM PLANE H IS LOCATED AT THE BOTTOM OF THE MOLD PARTING LINE COINCIDENT WITH WHERE THE LEAD EXITS THE BODY.
- DATUMS A-B AND D TO BE DETERMINED AT DATUM PLANE H.
- TO BE DETERMINED AT SEATING PLANE C.
- DIMENSIONS D1 AND E1 DO NOT INCLUDE MOLD PROTRUSION. ALLOWABLE PROTRUSION IS 0.25mm PRE SIDE. DIMENSIONS D1 AND E1 INCLUDE MOLD MISMATCH AND ARE DETERMINED AT DATUM PLANE H.
- DETAILS OF PIN 1 IDENTIFIER ARE OPTIONAL BUT MUST BE LOCATED WITHIN THE ZONE INDICATED.
- REGARDLESS OF THE RELATIVE SIZE OF THE UPPER AND LOWER BODY SECTIONS, DIMENSIONS D1 AND E1 ARE DETERMINED AT THE LARGEST FEATURE OF THE BODY EXCLUSIVE OF MOLD FLASH AND GATE BURRS, BUT INCLUDING ANY MISMATCH BETWEEN THE UPPER AND LOWER SECTIONS OF THE MOLDER BODY.
- DIMENSION b DOES NOT INCLUDE DAMBAR PROTRUSION. THE DAMBAR PROTRUSION (S) SHALL NOT CAUSE THE LEAD WIDTH TO EXCEED b MAXIMUM BY MORE THAN 0.08mm. DAMBAR CANNOT BE LOCATED ON THE LOWER RADIUS OR THE LEAD FOOT.
- THESE DIMENSIONS APPLY TO THE FLAT SECTION OF THE LEAD BETWEEN 0.10mm AND 0.25mm FROM THE LEAD TIP.
- A1 IS DEFINED AS THE DISTANCE FROM THE SEATING PLANE TO THE LOWEST POINT OF THE PACKAGE BODY.

002-14043 \*\*

 PACKAGE OUTLINE. 80 LEAD LQFP  
 14.0X14.0X1.7 MM LQJ080 REV\*\*

Package Type	Package Code
LQFP 64	LQD064

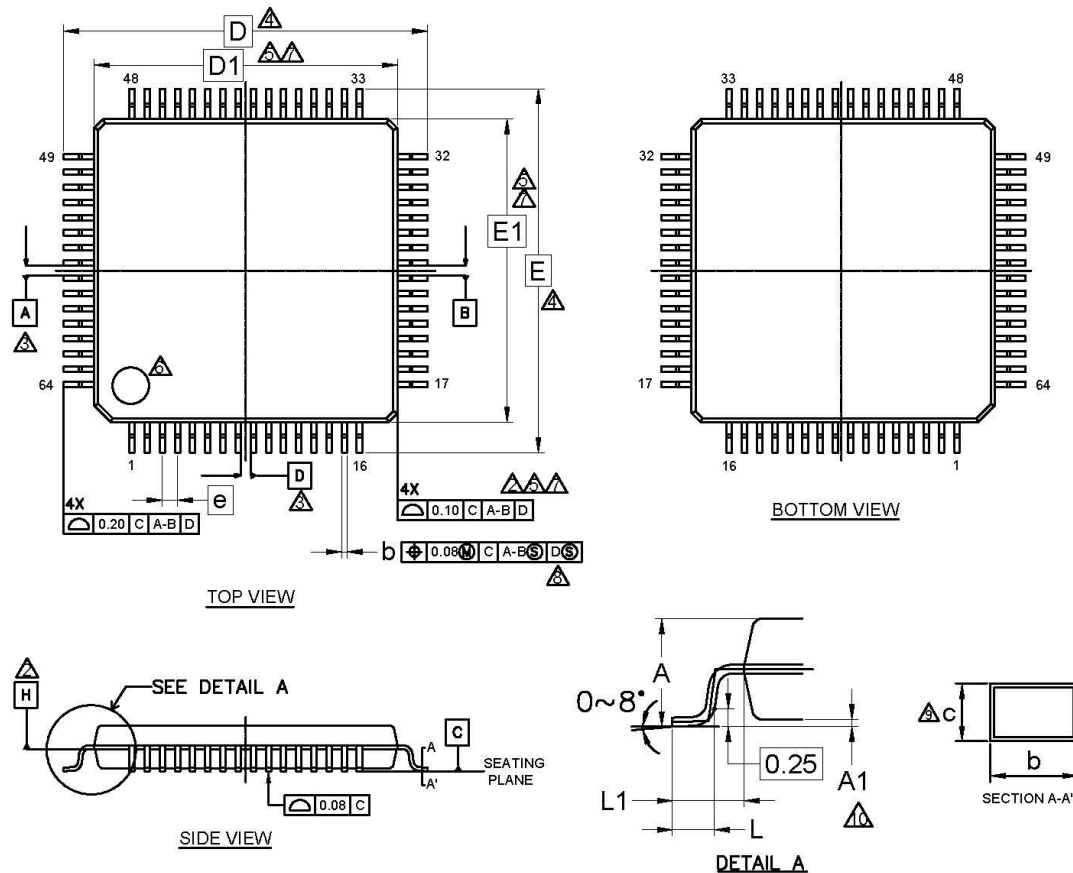

SYMBOL	DIMENSIONS		
	MIN.	NOM.	MAX.
A	—	—	1.70
A1	0.00	—	0.20
b	0.15	—	0.27
c	0.09	—	0.20
D	12.00 BSC.		
D1	10.00 BSC.		
e	0.50 BSC.		
E	12.00 BSC.		
E1	10.00 BSC.		
L	0.45	0.60	0.75
L1	1.00 REF.		

#### NOTES

- ALL DIMENSIONS ARE IN MILLIMETERS.
- DATUM PLANE H IS LOCATED AT THE BOTTOM OF THE MOLD PARTING LINE COINCIDENT WITH WHERE THE LEAD EXITS THE BODY.
- DATUMS A-B AND D TO BE DETERMINED AT DATUM PLANE H.
- TO BE DETERMINED AT SEATING PLANE C.
- DIMENSIONS D1 AND E1 DO NOT INCLUDE MOLD PROTRUSION. ALLOWABLE PROTRUSION IS 0.25mm PRE SIDE. DIMENSIONS D1 AND E1 INCLUDE MOLD MISMATCH AND ARE DETERMINED AT DATUM PLANE H.
- DETAILS OF PIN 1 IDENTIFIER ARE OPTIONAL BUT MUST BE LOCATED WITHIN THE ZONE INDICATED.
- REGARDLESS OF THE RELATIVE SIZE OF THE UPPER AND LOWER BODY SECTIONS, DIMENSIONS D1 AND E1 ARE DETERMINED AT THE LARGEST FEATURE OF THE BODY EXCLUSIVE OF MOLD FLASH AND GATE BURRS, BUT INCLUDING ANY MISMATCH BETWEEN THE UPPER AND LOWER SECTIONS OF THE MOLDER BODY.
- DIMENSION b DOES NOT INCLUDE DAMBAR PROTRUSION. THE DAMBAR PROTRUSION(S) SHALL NOT CAUSE THE LEAD WIDTH TO EXCEED b MAXIMUM BY MORE THAN 0.08mm. DAMBAR CANNOT BE LOCATED ON THE LOWER RADIUS OR THE LEAD FOOT.
- THESE DIMENSIONS APPLY TO THE FLAT SECTION OF THE LEAD BETWEEN 0.10mm AND 0.25mm FROM THE LEAD TIP.
- A1 IS DEFINED AS THE DISTANCE FROM THE SEATING PLANE TO THE LOWEST POINT OF THE PACKAGE BODY.

002-11499 \*A

<b>Package Type</b>	<b>Package Code</b>
LQFP 64	LQG064

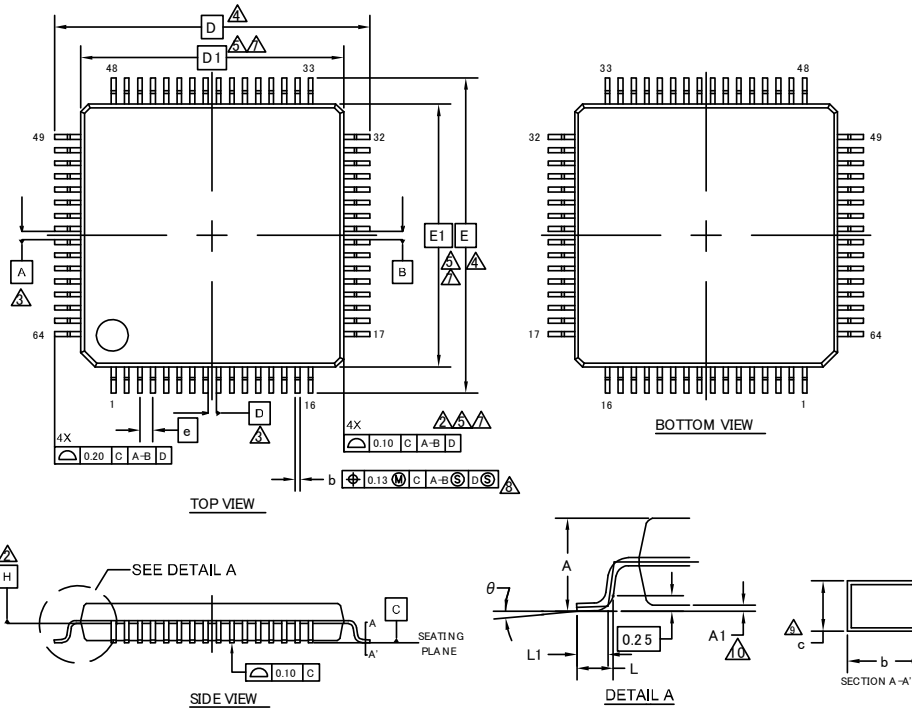

SYMBOL	DIMENSION		
	MIN.	NOM.	MAX.
A	—	—	1.70
A1	0.00	—	0.20
b	0.27	0.32	0.37
c	0.09	—	0.20
D	14.00 BSC		
D1	12.00 BSC		
e	0.65 BSC		
E	14.00 BSC		
E1	12.00 BSC		
L	0.45	0.60	0.75
L1	0.30	0.50	0.70
$\theta$	0°	—	8°

### NOTES

- ALL DIMENSIONS ARE IN MILLIMETERS.
- DATUM PLANE H IS LOCATED AT THE BOTTOM OF THE MOLD PARTING LINE COINCIDENT WITH WHERE THE LEAD EXITS THE BODY.
- DATUMS A-B AND D TO BE DETERMINED AT DATUM PLANE H.
- TO BE DETERMINED AT SEATING PLANE C.
- DIMENSIONS D1 AND E1 DO NOT INCLUDE MOLD PROTRUSION. ALLOWABLE PROTRUSION IS 0.25mm PRE SIDE. DIMENSIONS D1 AND E1 INCLUDE MOLD MISMATCH AND ARE DETERMINED AT DATUM PLANE H.
- DETAILS OF PIN 1 IDENTIFIER ARE OPTIONAL BUT MUST BE LOCATED WITHIN THE ZONE INDICATED.
- REGARDLESS OF THE RELATIVE SIZE OF THE UPPER AND LOWER BODY SECTIONS, DIMENSIONS D1 AND E1 ARE DETERMINED AT THE LARGEST FEATURE OF THE BODY EXCLUSIVE OF MOLD FLASH AND GATE BURRS, BUT INCLUDING ANY MISMATCH BETWEEN THE UPPER AND LOWER SECTIONS OF THE MOLDER BODY.
- DIMENSION b DOES NOT INCLUDE DAMBER PROTRUSION, THE DAMBAR PROTRUSION (S) SHALL NOT CAUSE THE LEAD WIDTH TO EXCEED b MAXIMUM BY MORE THAN 0.08mm. DAMBAR CANNOT BE LOCATED ON THE LOWER RADIUS OR THE LEAD FOOT.
- THESE DIMENSIONS APPLY TO THE FLAT SECTION OF THE LEAD BETWEEN 0.10mm AND 0.25mm FROM THE LEAD TIP.
- A1 IS DEFINED AS THE DISTANCE FROM THE SEATING PLANE TO THE LOWEST POINT OF THE PACKAGE BODY.

002-13881 \*\*

 PACKAGE OUTLINE, 64 LEAD LQFP  
 12.0X12.0X1.7 MM LQG064 REV\*\*

<b>Package Type</b>	<b>Package Code</b>
QFN 64	VNC064

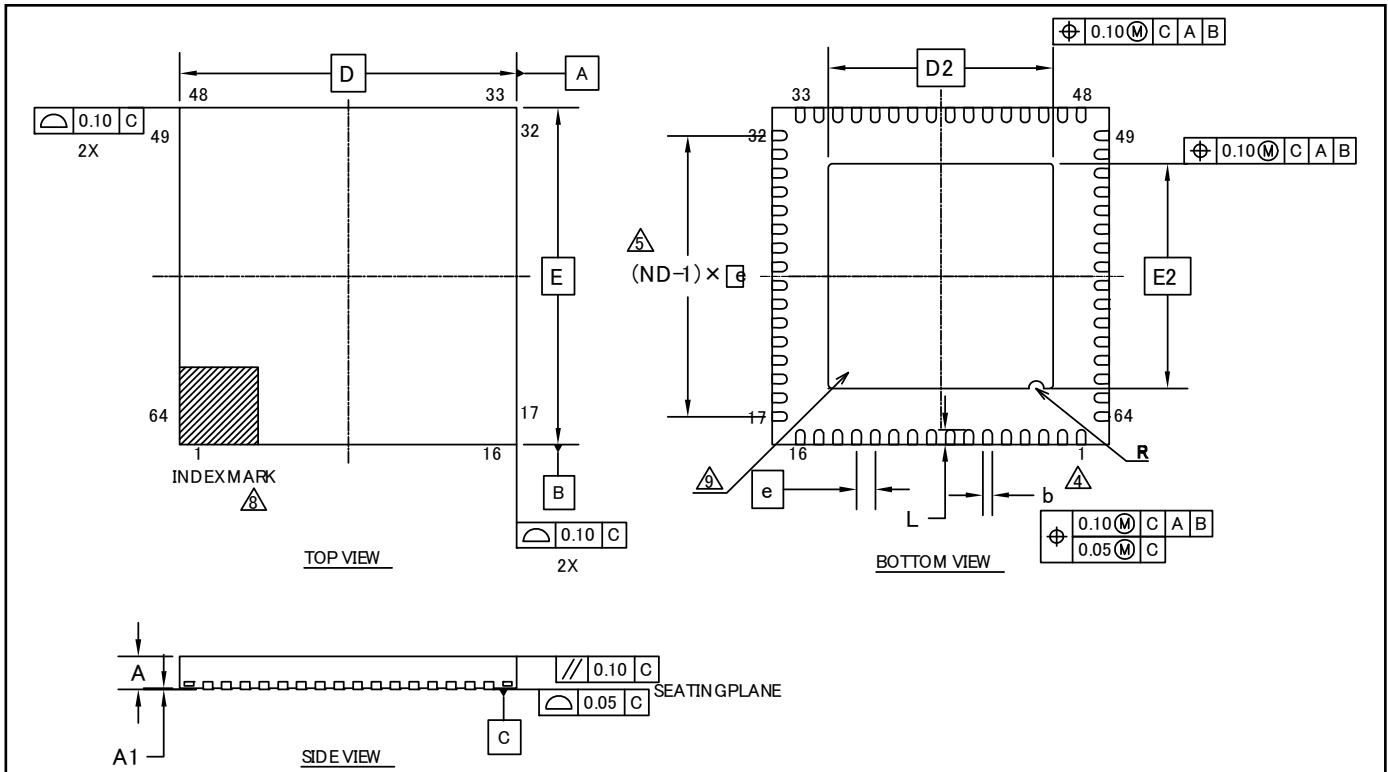

SYMBOL	DIMENSIONS		
	MIN.	NOM.	MAX.
A	—	—	0.90
A1	0.00	—	0.05
D	9.00 BSC		
E	9.00 BSC		
b	0.20	0.25	0.30
D2	6.00 BSC		
E2	6.00 BSC		
e	0.50 BSC		
R	0.20 REF		
L	0.35	0.40	0.45
N	64		
ND	16		

NOTES:

1. ALL DIMENSIONS ARE IN MILLIMETERS.
2. DIMENSIONING AND TOLERANCING CONFORMS TO ASME Y14.5M-1994.
3. N IS THE TOTAL NUMBER OF TERMINALS.
4. DIMENSION "b" APPLIES TO METALLIZED TERMINAL AND IS MEASURED BETWEEN 0.15 AND 0.30mm FROM TERMINAL TIP. IF THE TERMINAL HAS THE OPTIONAL RADIUS ON THE OTHER END OF THE TERMINAL, THE DIMENSION "b" SHOULD NOT BE MEASURED IN THAT RADIUS AREA.
5. ND REFERS TO THE NUMBER OF TERMINALS ON D SIDE OR E SIDE.
6. MAX. PACKAGE WARPAGE IS 0.05mm.
7. MAXIMUM ALLOWABLE BURR IS 0.076mm IN ALL DIRECTIONS.
8. PIN #1 ID ON TOP WILL BE LOCATED WITHIN THE INDICATED ZONE.
9. BILATERAL COPLANARITY ZONE APPLIES TO THE EXPOSED HEAT SINK SLUG AS WELL AS THE TERMINALS.

002-13234 \*\*

PACKAGE OUTLINE, 64 LEAD QFN  
9.0X9.0X0.9 MM VNC064 6.0X6.0 MM EPAD (SAWN) Rev.\*\*

<b>Package Type</b>	<b>Package Code</b>
LQFP 48	LQA048

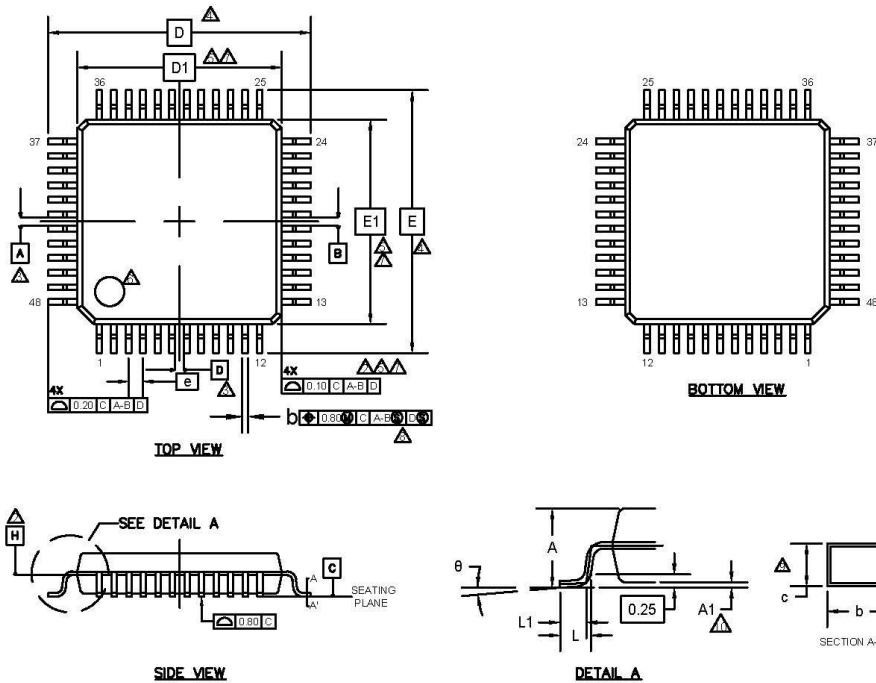

SYMBOL	DIMENSIONS		
	MIN.	NOM.	MAX.
A	—	—	1.70
A1	0.00	—	0.20
b	0.15	—	0.27
c	0.09	—	0.20
D	9.00 BSC		
D1	7.00 BSC		
e	0.50 BSC		
E	9.00 BSC		
E1	7.00 BSC		
L	0.45	0.60	0.75
L1	0.30	0.50	0.70
θ	0°	—	8°

### NOTES

- ALL DIMENSIONS ARE IN MILLIMETERS.
- DATUM PLANE H IS LOCATED AT THE BOTTOM OF THE MOLD PARTING LINE COINCIDENT WITH WHERE THE LEAD EXITS THE BODY.
- DATUMS A–B AND D TO BE DETERMINED AT DATUM PLANE H.
- DATUMS C AND E TO BE DETERMINED AT SEATING PLANE C.
- DIMENSIONS D1 AND E1 DO NOT INCLUDE MOLD PROTRUSION. ALLOWABLE PROTRUSION IS 0.25mm PRE SIDE. DIMENSIONS D1 AND E1 INCLUDE MOLD MISMATCH AND ARE DETERMINED AT DATUM PLANE H.
- DETAILS OF PIN 1 IDENTIFIER ARE OPTIONAL BUT MUST BE LOCATED WITHIN THE ZONE INDICATED.
- REGARDLESS OF THE RELATIVE SIZE OF THE UPPER AND LOWER BODY SECTIONS, DIMENSIONS D1 AND E1 ARE DETERMINED AT THE LARGEST FEATURE OF THE BODY EXCLUSIVE OF MOLD FLASH AND GATE BURRS, BUT INCLUDING ANY MISMATCH BETWEEN THE UPPER AND LOWER SECTIONS OF THE MOLDER BODY.
- DIMENSION b DOES NOT INCLUDE DAMBAR PROTRUSION. THE DAMBAR PROTRUSION(S) SHALL NOT CAUSE THE LEAD WIDTH TO EXCEED b MAXIMUM BY MORE THAN 0.08mm. DAMBAR CANNOT BE LOCATED ON THE LOWER RADIUS OR THE LEAD FOOT.
- THESE DIMENSIONS APPLY TO THE FLAT SECTION OF THE LEAD BETWEEN 0.10mm AND 0.25mm FROM THE LEAD TIP.
- A1 IS DEFINED AS THE DISTANCE FROM THE SEATING PLANE TO THE LOWEST POINT OF THE PACKAGE BODY.

002-13731 \*A

<b>Package Type</b>	<b>Package Code</b>
QFN 48	VNA048

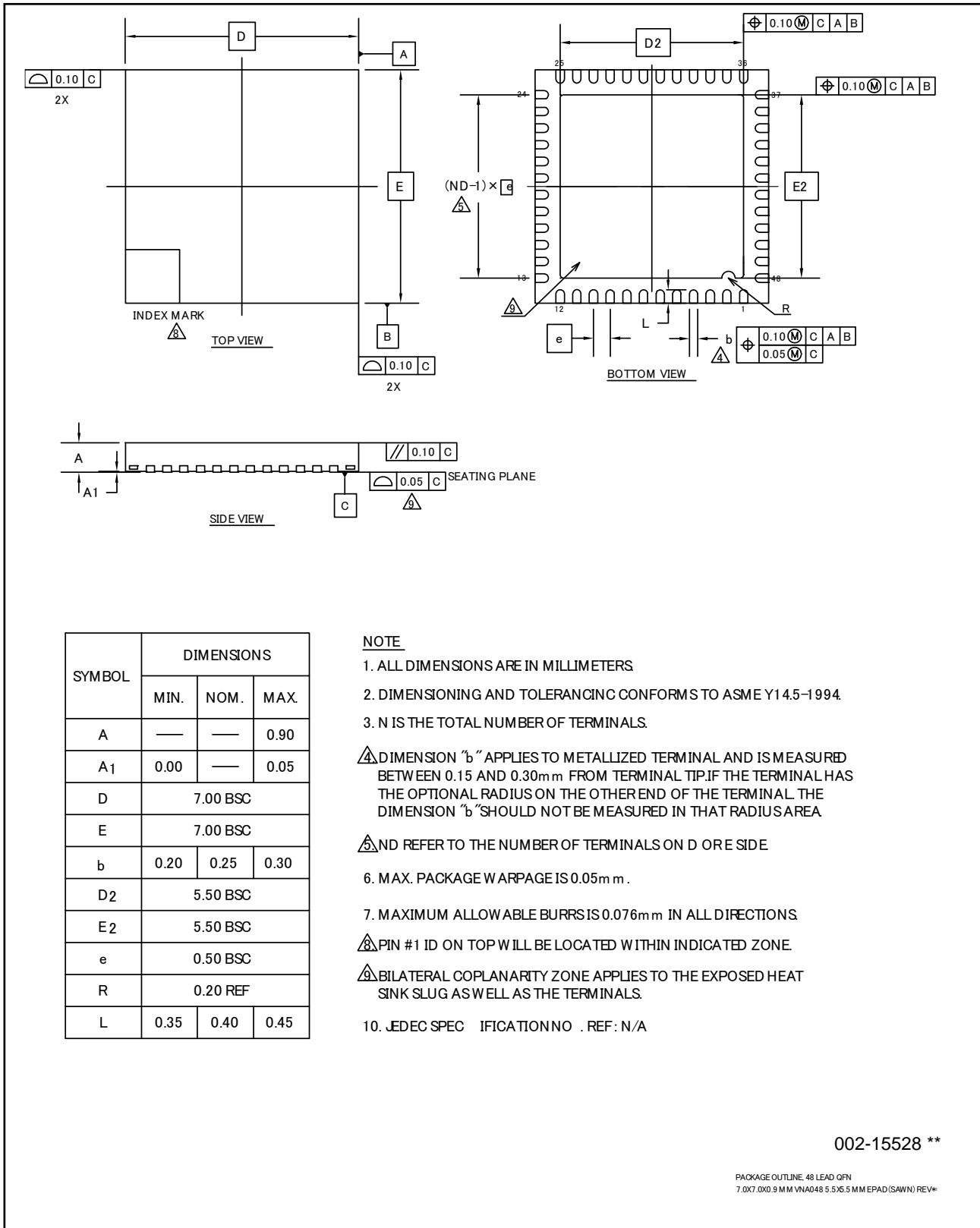

SYMBOL	DIMENSIONS		
	MIN.	NOM.	MAX.
A	—	—	0.90
A1	0.00	—	0.05
D	7.00 BSC		
E	7.00 BSC		
b	0.20	0.25	0.30
D2	5.50 BSC		
E2	5.50 BSC		
e	0.50 BSC		
R	0.20 REF		
L	0.35	0.40	0.45

- NOTE**
- ALL DIMENSIONS ARE IN MILLIMETERS
  - DIMENSIONING AND TOLERANCING CONFORMS TO ASME Y14.5-1994.
  - N IS THE TOTAL NUMBER OF TERMINALS.
  - $\Delta$  DIMENSION "b" APPLIES TO METALLIZED TERMINAL AND IS MEASURED BETWEEN 0.15 AND 0.30mm FROM TERMINAL TIP. IF THE TERMINAL HAS THE OPTIONAL RADIUS ON THE OTHER END OF THE TERMINAL THE DIMENSION "b" SHOULD NOT BE MEASURED IN THAT RADIUS AREA.
  - $\Delta$  ND REFER TO THE NUMBER OF TERMINALS ON D ORE SIDE
  - MAX. PACKAGE WARPAGE IS 0.05mm.
  - MAXIMUM ALLOWABLE BURRS IS 0.076mm IN ALL DIRECTIONS.
  - $\Delta$  PIN #1 ID ON TOP WILL BE LOCATED WITHIN INDICATED ZONE.
  - $\Delta$  BILATERAL COPLANARITY ZONE APPLIES TO THE EXPOSED HEAT SINK SLUG AS WELL AS THE TERMINALS.
  - JEDEC SPEC IFICATION NO . REF: N/A

002-15528 \*\*

PACKAGE OUTLINE, 48 LEAD QFN  
7.0X7.0X0.9 MM VNA048 5.5X5.5 MM EPAD (SAWN) REV\*

<b>Package Type</b>	<b>Package Code</b>
FBGA 96	FDG096

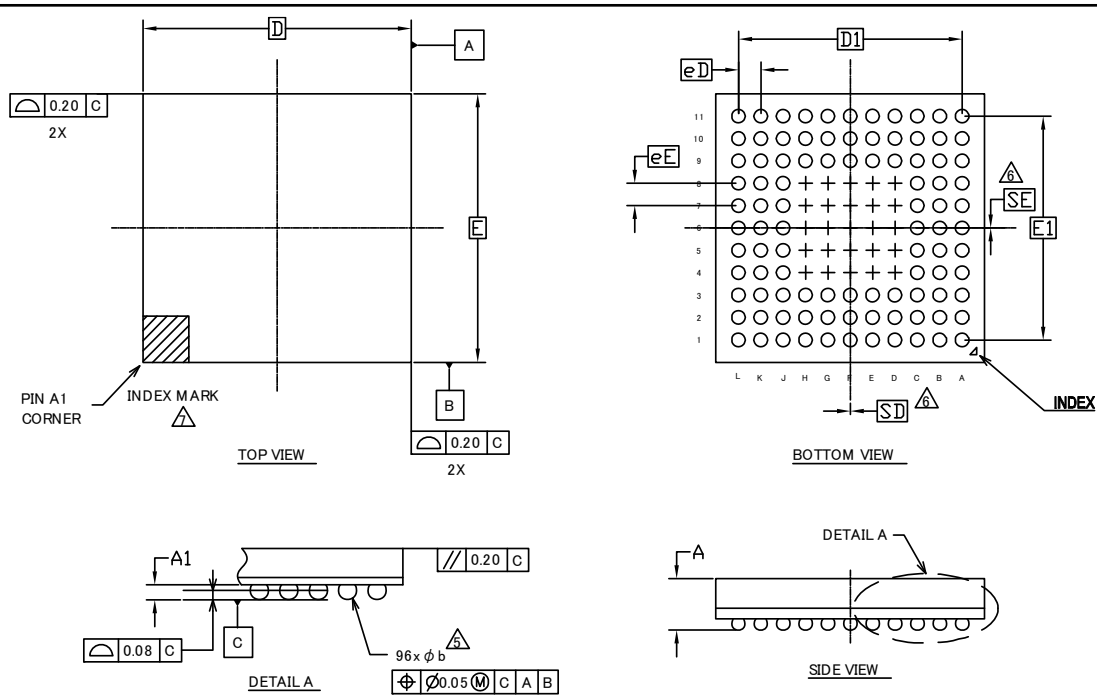
**NOTES:**

- ALL DIMENSIONS ARE IN MILLIMETERS.
- SOLDER BALL POSITION DESIGNATION PER JEP95, SECTION 3, SPP-020.
- "e" REPRESENTS THE SOLDER BALL GRID PITCH.
- SYMBOL "MD" IS THE BALL MATRIX SIZE IN THE "D" DIRECTION. SYMBOL "ME" IS THE BALL MATRIX SIZE IN THE "E" DIRECTION. N IS THE NUMBER OF POPULATED SOLDER BALL POSITIONS FOR MATRIX SIZE MD X ME.
- DIMENSION "b" IS MEASURED AT THE MAXIMUM BALL DIAMETER IN A PLANE PARALLEL TO DATUM C.
- "SD" AND "SE" ARE MEASURED WITH RESPECT TO DATUMS A AND B AND DEFINE THE POSITION OF THE CENTER SOLDER BALL IN THE OUTER ROW. WHEN THERE IS AN ODD NUMBER OF SOLDER BALLS IN THE OUTER ROW, "SD" OR "SE" = 0. WHEN THERE IS AN EVEN NUMBER OF SOLDER BALLS IN THE OUTER ROW, "SD" = eD/2 AND "SE" = eE/2.
- A1 CORNER TO BE IDENTIFIED BY CHAMFER, LASER OR INK MARK METALIZED MARK, INDENTATION OR OTHER MEANS.
- "+" INDICATES THE THEORETICAL CENTER OF DEPOPULATED SOLDER BALLS.

SYMBOL	DIMENSIONS		
	MIN.	NOM.	MAX.
A	-	-	1.30
A1	0.15	0.25	0.35
D	6.00 BSC		
E	6.00 BSC		
D1	5.00 BSC		
E1	5.00 BSC		
MD	11		
ME	11		
N	96		
Ø b	0.20	0.30	0.40
eD	0.50 BSC		
eE	0.50 BSC		
SD	0.00		
SE	0.00		

002-13224 \*\*

 PACKAGE OUTLINE, 96 BALL FBGA  
 6.0X6.0X1.3 MM FDG096 REV\*\*

## 15. Major Changes

Spanision Publication Number: DS706-00048

Page	Section	Change Results
Revision 1.0		
-	-	Preliminary → Data Sheet
2	Features Can Interface	Corrected the following description. CAN Interface (Max 2channels) → CAN Interface
3	A/D Converter (Max 26channels)	Revised the conversion time: 1.0μs → 0.8μs
6	Uniqueid	Added the "Unique ID".
7	Product Lineup Function	Added the "Unique ID".
16 to 18	List Of Pin Functions List Of Pin Numbers	Corrected the I/O circuit type. Corrected the Pin state type.
33	List Of Pin Functions	Corrected the Pin function.
39	I/O Circuit Type	Added the "Type: L".
46	Block Diagram	Corrected the figure. - TIOA: input → input/output - TIOB: output → input
55	Electrical Characteristics 1. Absolute Maximum Ratings	Revised the value of "TBD".
57	2. Recommended Operating Conditions	Revised the Condition of "Operating temperature".
58, 59	3. Dc Characteristics (1) Current Rating	Revised the value of "TBD". Added "Flash memory write/erase current".
62	4. Ac Characteristics (3) Built-In Cr Oscillation Characteristics	Revised the Condition. Revised the footnote.
63	(4-2) Operating Conditions Of Main PLL (In The Case Of Using Built-In High-Speed CR For Input Clock Of Main PLL)	Revised the value of "TBD".
79	5. 12-Bit A/D Converter Electrical Characteristics For The A/D Converter	Deleted "(Preliminary value)". Revised the conversion time. Min: 1.0μs → 0.8μs Revised the value of "Compare clock cycle ( $AV_{CC} \geq 4.5V$ )". Min: 50ns → 40ns Revised the footnote.
82	6. 10-Bit D/A Converter	Deleted "(Preliminary value)".
87	8. Low-Voltage Detection Characteristics	Revised the value of "TBD".
88	9. Mainflash Memory Write/Erase Characteristics	Revised the value of "TBD". Revised the value of "Sector erase time". - Large Sector Typ: 1.065s → 1.1s - Small Sector Typ: 0.606s → 0.3s Revised the value of "Chip erase time". Typ: 9.11s → 6.8s Deleted "(targeted value)".
Revision 1.1		
-	-	Company name and layout design change
Revision 2.0		
2	Features On-Chip Memories [Flash Memory]	Revised the features of Dual operation Flash memory
	USB Interface [USB Function]	Added the size of each endpoint.
3	Multi-Function Serial Interface [I <sup>2</sup> C]	Corrected the mode. High speed mode → Fast mode
4	General-Purpose I/O Port	Revised the features of 5V tolerant I/O.
	Multi-Function Timer	Corrected the number of A/D activating compare channels. 3ch. → 2ch.

Page	Section	Change Results
7	Product Lineup Function	Corrected the number of A/D activating compare channels. 3ch. → 2ch. Revised Built-in CR . High-speed: 4MHz(± 2%) → 4MHz Low-speed: 100kHz(Typ) → 100kHz
8		Revised the footnote.
21	List Of Pin Functions List Of Pin Numbers	Corrected the pin number of ZIN1_1.
24	List Of Pin Functions	Corrected the pin number of ADTG_2.
29		Corrected pin numbers of SIN0_1 and SOT0_1.
31		Corrected the pin number of DTTI0X_2.
37	I/O Circuit Type	Corrected the I/O circuit figure. TYPE H : GPIO Digital input → GPIO Digital output
44	Handling Devices Sub Crystal Oscillator	Added the descriptions.
47	Block Diagram	Corrected the figure. -A/D Activation Compare: 3ch → 2ch
49	Memory Map Memory Map (2)	Added the explanatory note.
54	Pin Status In Each Cpu State List Of Pin Status	Added the pin function of selected Analog output about type L.
55		Corrected the footnote. Sub CR timer → Low-speed CR tim
58	Electrical Characteristics 2. Recommended Operating Conditions	Added the note and footnote. Corrected the value of Analog reference voltage "AVRH". Min.: AVss → 2.7
59	3. Dc Characteristics (1) Current Rating	Added notes and footnotes. Added the remarks of Icc. Added the frequency of main clock crystal oscillator in remarks.
63	4. Ac Characteristics (2) Sub Clock Input Characteristics	Added the footnote.
64	(3) Built-In CR Oscillation Characteristics Built-In High-Speed CR	Added "Frequency stabilization time" Added notes and footnotes.
66	(6) Power-On Reset Timing	Added "Timing until releasing Power-on reset" Added the timing chart
68	(8) Csi0 Timing	Corrected the title. UART Timing → CSIO Timing Corrected the notefoot. UART → Multi-function serial
70,72,74		Corrected the notefoot. UART → Multi-function serial
79	(11) I <sup>2</sup> c Timing	Revised the Condition. Revised the footnote.
81	5. 12-Bit A/D Converter Electrical Characteristics For The A/D Converter	Changed the name of parameter. •Non Linearity error → Integral Nonlinearity •Differential linearity error → Differential Nonlinearity Changed the Symbol. Of Zero transition voltage. V <sub>0T</sub> → V <sub>ZT</sub> Changed the pin name. AN00 to AN26 → ANxx Corrected the value of V <sub>0T</sub> , V <sub>FST</sub> , T <sub>s</sub> , T <sub>stt</sub> , and reference voltage. Revises footnotes.
82		Change the figure. AN00 to AN26 → ANxx
83	Definition Of 12-Bit A/D Converter Terms	•Linearity error → Integral Nonlinearity •Differential linearity error → Differential Nonlinearity V <sub>0T</sub> → V <sub>ZT</sub>
84	6. 10-Bit D/A Converter Electrical Characteristics For The D/A Converter	•Revised the remark of IDDA. D/A operation → D/A 1unit operation Changed the name of parameter. •Linearity error → Integral Nonlinearity •Differential linearity error → Differential Nonlinearity

Page	Section	Change Results
89	8. Low-Voltage Detection Characteristics (1) Low-Voltage Detection Reset	Corrected the condition and the value. Added the note and the footnote. Added "LVD detection delay time".
90	(2) Interrupt Of Low-Voltage Detection	Corrected the condition and the value. Added "LVD detection delay time".
91	9. Flash Memory Write/Erase Characteristics	Changed the title of Chapter. Main Flash Memory Write/Erase Characteristics → Flash Memory Write/Erase Characteristics
92	10. Return Time Low-Power Consumption Mode	Added the Chapter "Return Time from Low-Power Consumption Mode".
Revision 3.0		
2	Features Usb Interface	Added The Description Of Pll For Usb
36, 37	I/O Circuit Type	Added About +B Input
49	Memory Map · Memory Map(2)	Added The Summary Of Flash Memory Sector And The Note
54	PIN STATUS IN EACH CPU STAE · List Of Pin Status	Changed The Pin Status Of I-Type
56, 57	Electrical Characteristics 1. Absolute Maximum Ratings	· Added The Clamp Maximum Current · Added About +B Input
59-61	Electrical Characteristics 3. DC Characteristics (1) Current Rating	· Changed The Table Format · Added Main TIMER Mode Current · Moved A/D Converter Current · Moved D/A Converter Current
66	Electrical Characteristics 4. AC Characteristics (4-1) Operating Conditions Of Main And USB PLL (4-2) Operating Conditions Of Main PLL	· Added The Figure Of Main PLL Connection And USB PLL Connection
69-76	Electrical Characteristics 4. Ac Characteristics (7) Csio/Uart Timing	· Modified From Uart Timing To Csio/Uart Timing · Changed From Internal Shift Clock Operation To Master Mode · Changed From External Shift Clock Operation To Slave Mode
77	Electrical Characteristics 4. Ac Characteristics (9) External Input Timing	Added Input Pulse Width Of Wkupx Pin
82	Electrical Characteristics 5. 12bit A/D Converter	· Added The Typical Value Of Integral Nonlinearity, Differential Nonlinearity, Zero Transition Voltage And Full-Scale Transition Voltage · Added Conversion Time At Avcc < 4.5V
97, 98	Ordering Information	Change To Full Part Number

**Note: Please see "Document History" about later revised information.**

Document History

Document Title: CY9B520M Series, 32-bit Arm® Cortex®-M3 FM3 Microcontroller  
 Document Number: 002-05649

Revision	ECN	Orig. of Change	Submission Date	Description of Change
**	–	TOYO	09/13/2012	Migrated to Cypress and assigned document number 002-05649. No change to document contents or format.
*A	5164786	TOYO	03/07/2016	Updated to Cypress template.
*B	5653470	HTER	03/09/2017	<ul style="list-style-type: none"> <li>• Modified RTC description in “Features, Real-Time Clock (RTC)” . Changed starting count value from 01 to 00. Deleted “second, or day of the week” in the Interrupt function. (Page 3)</li> <li>• Updated Package code and dimensions as follows (Page 8-14, 95-103)               <ul style="list-style-type: none"> <li>- FPT-48P-M49 -&gt; LQA048</li> <li>- LCC-48P-M73 -&gt; VNA048</li> <li>- FPT-64P-M38 -&gt; LQD064</li> <li>- FPT-64P-M39 -&gt; LQG064</li> <li>- LCC-64P-M24 -&gt; VNC064</li> <li>- FPT-80P-M37 -&gt; LQH080</li> <li>- FPT-80P-M40 -&gt; LQJ080</li> <li>- BGA-96P-M07 -&gt; FDG096</li> </ul> </li> <li>• Added Notes for JTAG. (Page 32)</li> <li>• Updated “12.4.7 Power-On Reset Timing” . Changed parameter from “Power Supply rise time (Tr) [ms]” to “Power ramp rate (dV/dt) [mV/us]” and add some comments. (Page 65)</li> <li>• Added the Baud rate spec in “12.4.9 CSIO/UART Timing”.(Page 67-73)</li> <li>• Corrected the erroneous descriptions as follows.               <ul style="list-style-type: none"> <li>- “USB Function” -&gt; “USB Device” (Page 1, 7, 31, 44)</li> <li>- “J-TAG” -&gt; “JTAG” (Page 24)</li> <li>- “Analog port input current” -&gt; “Analog port input leak current” (Page 80)</li> </ul> </li> </ul>
*C	5764936	AESATMP9	06/15/2017	Updated Cypress Logo and Copyright.
*D	6064687	HUAL	02/09/2018	Updated to new template. Completing Sunset Review.
*E	6604852	XITO	06/26/2019	Updated Ordering Information: Updated part numbers. Updated to new template.
*F	6886941	XITO	06/18/2020	Updated Document Title to read as “CY9B520M Series, 32-bit Arm® Cortex®-M3 FM3 Microcontroller”. Replaced MB9B520M with CY9B520M in all instances across the document. Updated Ordering Information: Updated part numbers.

*G	7908920	XITO	05/26/2023	<p>Updated Ordering Information:  Updated part numbers.  Updated Package Dimensions:  Spec 002-11501 – Changed revision from ** to *A.  Spec 002-11499 – Changed revision from ** to *A.  Spec 002-13731 – Changed revision from ** to *A.  Completing Sunset Review.</p>
----	---------	------	------------	---

## Sales, Solutions, and Legal Information

### Worldwide Sales and Design Support

Cypress maintains a worldwide network of offices, solution centers, manufacturer's representatives, and distributors. To find the office closest to you, visit us at [Cypress Locations](#).

### Products

Arm® Cortex® Microcontrollers	<a href="http://cypress.com/arm">cypress.com/arm</a>
Automotive	<a href="http://cypress.com/automotive">cypress.com/automotive</a>
Clocks & Buffers	<a href="http://cypress.com/clocks">cypress.com/clocks</a>
Interface	<a href="http://cypress.com/interface">cypress.com/interface</a>
Internet of Things	<a href="http://cypress.com/iot">cypress.com/iot</a>
Memory	<a href="http://cypress.com/memory">cypress.com/memory</a>
Microcontrollers	<a href="http://cypress.com/mcu">cypress.com/mcu</a>
PSoC	<a href="http://cypress.com/psoc">cypress.com/psoc</a>
Power Management ICs	<a href="http://cypress.com/pmhc">cypress.com/pmhc</a>
Touch Sensing	<a href="http://cypress.com/touch">cypress.com/touch</a>
USB Controllers	<a href="http://cypress.com/usb">cypress.com/usb</a>
Wireless Connectivity	<a href="http://cypress.com/wireless">cypress.com/wireless</a>

### PSoC® Solutions

[PSoC 1](#) | [PSoC 3](#) | [PSoC 4](#) | [PSoC 5LP](#) | [PSoC 6 MCU](#)

### Cypress Developer Community

[Community](#) | [Projects](#) | [Videos](#) | [Blogs](#) | [Training](#) | [Components](#)

### Technical Support

[cypress.com/support](http://cypress.com/support)

Arm and Cortex are registered trademarks of Arm Limited (or its subsidiaries) in the US and/or elsewhere.



© Cypress Semiconductor Corporation, 2012-2023. This document is the property of Cypress Semiconductor Corporation and its subsidiaries ("Cypress"). This document, including any software or firmware included or referenced in this document ("Software"), is owned by Cypress under the intellectual property laws and treaties of the United States and other countries worldwide. Cypress reserves all rights under such laws and treaties and does not, except as specifically stated in this paragraph, grant any license under its patents, copyrights, trademarks, or other intellectual property rights. If the Software is not accompanied by a license agreement and you do not otherwise have a written agreement with Cypress governing the use of the Software, then Cypress hereby grants you a personal, non-exclusive, nontransferable license (without the right to sublicense) (1) under its copyright rights in the Software (a) for Software provided in source code form, to modify and reproduce the Software solely for use with Cypress hardware products, only internally within your organization, and (b) to distribute the Software in binary code form externally to end users (either directly or indirectly through resellers and distributors), solely for use on Cypress hardware product units, and (2) under those claims of Cypress's patents that are infringed by the Software (as provided by Cypress, unmodified) to make, use, distribute, and import the Software solely for use with Cypress hardware products. Any other use, reproduction, modification, translation, or compilation of the Software is prohibited.

TO THE EXTENT PERMITTED BY APPLICABLE LAW, CYPRESS MAKES NO WARRANTY OF ANY KIND, EXPRESS OR IMPLIED, WITH REGARD TO THIS DOCUMENT OR ANY SOFTWARE OR ACCOMPANYING HARDWARE, INCLUDING, BUT NOT LIMITED TO, THE IMPLIED WARRANTIES OF MERCHANTABILITY AND FITNESS FOR A PARTICULAR PURPOSE. No computing device can be absolutely secure. Therefore, despite security measures implemented in Cypress hardware or software products, Cypress shall have no liability arising out of any security breach, such as unauthorized access to or use of a Cypress product. CYPRESS DOES NOT REPRESENT, WARRANT, OR GUARANTEE THAT CYPRESS PRODUCTS, OR SYSTEMS CREATED USING CYPRESS PRODUCTS, WILL BE FREE FROM CORRUPTION, ATTACK, VIRUSES, INTERFERENCE, HACKING, DATA LOSS OR THEFT, OR OTHER SECURITY INTRUSION (collectively, "Security Breach"). Cypress disclaims any liability relating to any Security Breach, and you shall and hereby do release Cypress from any claim, damage, or other liability arising from any Security Breach. In addition, the products described in these materials may contain design defects or errors known as errata which may cause the product to deviate from published specifications. To the extent permitted by applicable law, Cypress reserves the right to make changes to this document without further notice. Cypress does not assume any liability arising out of the application or use of any product or circuit described in this document. Any information provided in this document, including any sample design information or programming code, is provided only for reference purposes. It is the responsibility of the user of this document to properly design, program, and test the functionality and safety of any application made of this information and any resulting product. "High-Risk Device" means any device or system whose failure could cause personal injury, death, or property damage. Examples of High-Risk Devices are weapons, nuclear installations, surgical implants, and other medical devices. "Critical Component" means any component of a High-Risk Device whose failure to perform can be reasonably expected to cause, directly or indirectly, the failure of the High-Risk Device, or to affect its safety or effectiveness. Cypress is not liable, in whole or in part, and you shall and hereby do release Cypress from any claim, damage, or other liability arising from any use of a Cypress product as a Critical Component in a High-Risk Device. You shall indemnify and hold Cypress, its directors, officers, employees, agents, affiliates, distributors, and assigns harmless from and against all claims, costs, damages, and expenses, arising out of any claim, including claims for product liability, personal injury or death, or property damage arising from any use of a Cypress product as a Critical Component in a High-Risk Device. Cypress products are not intended or authorized for use as a Critical Component in any High-Risk Device except to the limited extent that (i) Cypress's published data sheet for the product explicitly states Cypress has qualified the product for use in a specific High-Risk Device, or (ii) Cypress has given you advance written authorization to use the product as a Critical Component in the specific High-Risk Device and you have signed a separate indemnification agreement.







Cypress, the Cypress logo, Spansion, the Spansion logo, and combinations thereof, WICED, PSoC, CapSense, EZ-USB, F-RAM, and Traveo are trademarks or registered trademarks of Cypress in the United States and other countries. For a more complete list of Cypress trademarks, visit [cypress.com](http://cypress.com). Other names and brands may be claimed as property of their respective owners.

## Looking for pricing, stock, or lifecycle information?

Click below to explore more details on WIN SOURCE:

-  [View CY9BF524KPMC-G-MNE2 on WIN SOURCE](#)
-  [Infineon Technologies](#) Information

## Optimize Your Supply Chain with WIN SOURCE Solutions

-  Global Sourcing Solution
-  Obsolete Management
-  Cost Control Management
-  Shortage Management
-  Alternative Solution
-  Excess Inventory Management