

Data Sheet, V 1.0, May 2003

C868

8-Bit Single-Chip Microcontroller

8bit

Microcontrollers



Never stop thinking.

Edition 2003-05

**Published by Infineon Technologies AG,
St.-Martin-Strasse 53,
D-81541 München, Germany**

**© Infineon Technologies AG 2003.
All Rights Reserved.**

Attention please!

The information herein is given to describe certain components and shall not be considered as warranted characteristics.

Terms of delivery and rights to technical change reserved.

We hereby disclaim any and all warranties, including but not limited to warranties of non-infringement, regarding circuits, descriptions and charts stated herein.

Infineon Technologies is an approved CECC manufacturer.

Information

For further information on technology, delivery terms and conditions and prices please contact your nearest Infineon Technologies Office in Germany or our Infineon Technologies Representatives worldwide (see address list).

Warnings

Due to technical requirements components may contain dangerous substances. For information on the types in question please contact your nearest Infineon Technologies Office.

Infineon Technologies Components may only be used in life-support devices or systems with the express written approval of Infineon Technologies, if a failure of such components can reasonably be expected to cause the failure of that life-support device or system, or to affect the safety or effectiveness of that device or system. Life support devices or systems are intended to be implanted in the human body, or to support and/or maintain and sustain and/or protect human life. If they fail, it is reasonable to assume that the health of the user or other persons may be endangered.

C868

8-Bit Single-Chip Microcontroller

Microcontrollers



Never stop thinking.

C868

Revision History: **2003-05**

V 1.0

Previous Version: -

| Page | Subjects (major changes since last revision) |
|------|--|
| | Current data updated |
| | Description of I2C included |
| | |
| | |
| | |

We Listen to Your Comments

Any information within this document that you feel is wrong, unclear or missing at all?
Your feedback will help us to continuously improve the quality of this document.

Please send your proposal (including a reference to this document) to:

mcdocu.comments@infineon.com





**8-Bit Single-Chip Microcontroller
C800 Family**

C868

C868

Advance Information

- C800 core :
 - Fully compatible to standard 8051 microcontroller
 - Superset of the 8051 architecture with 8 datapointers
- 40 MHz internal CPU clock
 - external clock of 6.67 - 10.67 MHz at 50% duty cycle
 - 300 ns instruction cycle time (@37.5 MHz CPU clock)
- 8 Kbyte on-chip Program ROM for C868-1R and 8 KByte on-chip Program RAM for C868-1S
- In-system programming support for programming the XRAM(C868-1R) or XRAM/Program RAM(C868-1S)
 - This feature is realized through 4KB Boot ROM
- 256 byte on-chip RAM
- 256 byte on-chip XRAM

(further features are on the next page)

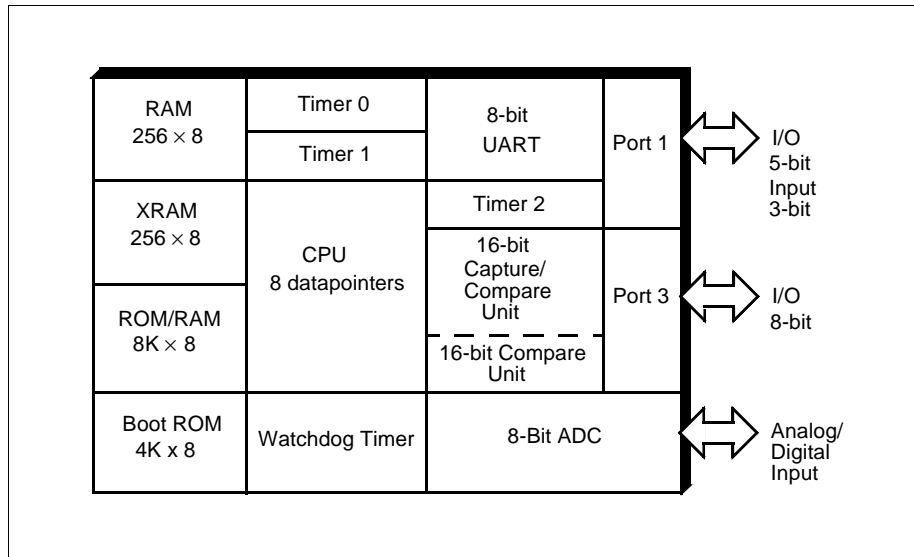

Figure 1 C868 Functional Units

- One 8-bit and one 5 bits general purpose push-pull I/O ports
 - Enhanced sink current of 10 mA on Port 1/3 (total max current of 43 mA @ 100°C)
- Three 16-bit timers/counters
 - Timer 0 / 1 (C501 compatible)
 - Timer 2 (up/down counter feature)
 - Timer 1 or 2 can be used for serial baudrate generator
- Capture/compare unit for PWM signal generation
 - 3-channel, 16-bit capture/compare unit
 - 1-channel, 16-bit compare unit
- Full duplex serial interface (UART)
- 5 channel 8-bit A/D Converter
 - Start of conversion can be synchronized to capture/compare timer 12/13.
- 13 interrupt vectors with four priority levels
- Programmable 16-bit Watchdog Timer
- Brown out detection
- Power Saving Modes
 - Slow-down mode
 - Idle mode (can be combined with slow-down mode)
 - Power-down mode with wake up capability through $\overline{INT0}$ or RxD pins.
- Single power supply of 3.3V, internal voltage regulator for core voltage of 2.5V.
- P-DSO-28-1, P-TSSOP-38-1 packages
- Temperature ranges:
 - SAF-C868-1RR BA, SAF-C868-1SR BA, SAF-C868-1RG BA, SAF-C868-1SG BA,
 - SAF-C868A-1RR BA, SAF-C868A-1SR BA, SAF-C868A-1RG BA, SAF-C868A-1SG
 - BA, SAF-C868P-1SR BA, SAF-C868P-1SG BA $T_A = -40$ to 85 °C
 - SAK-C868-1RR BA, SAK-C868-1SR BA, SAK-C868-1RG BA, SAK-C868-1SG BA,
 - SAK-C868A-1RR BA, SAK-C868A-1SR BA, SAK-C868A-1RG BA, SAK-C868A-1SG
 - BA, SAK-C868P-1SR BA, SAK-C868P-1SG BA $T_A = -40$ to 125 °C

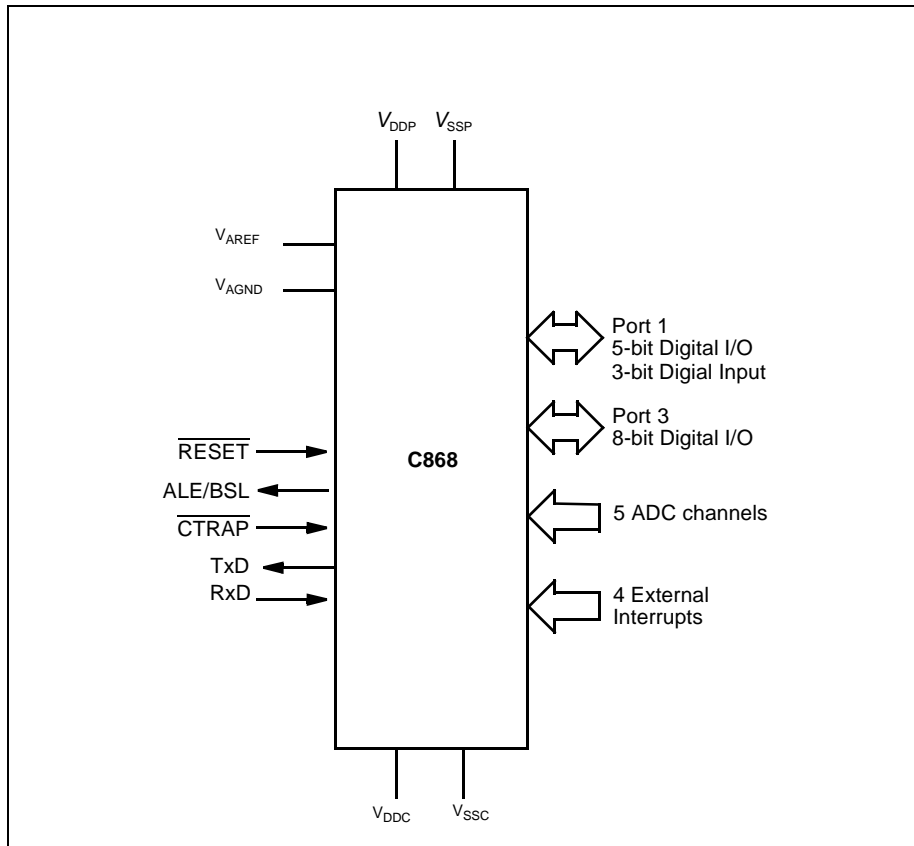

Figure 2 Logic Symbol

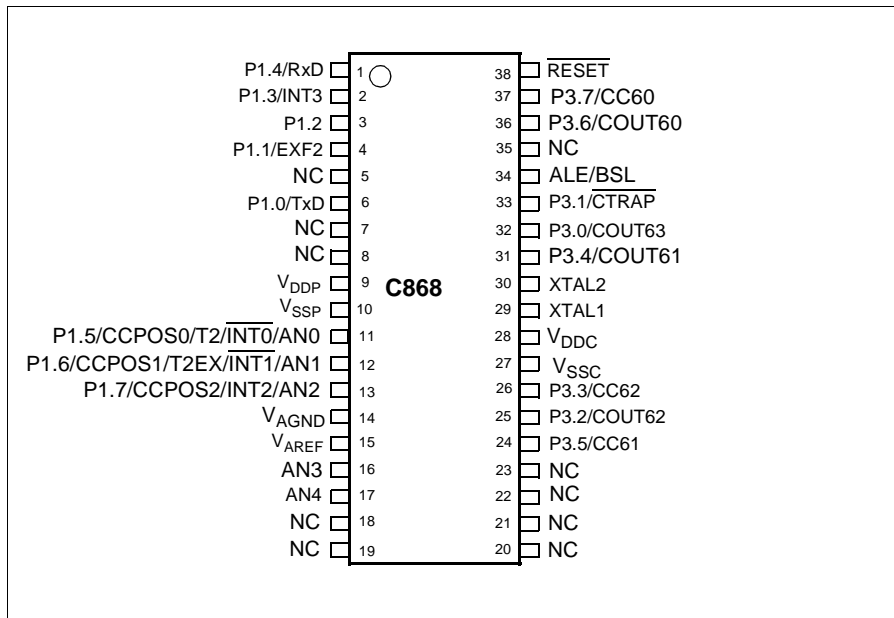

Figure 3 C868 Pin Configuration P-TSSOP-38 Package (top view)

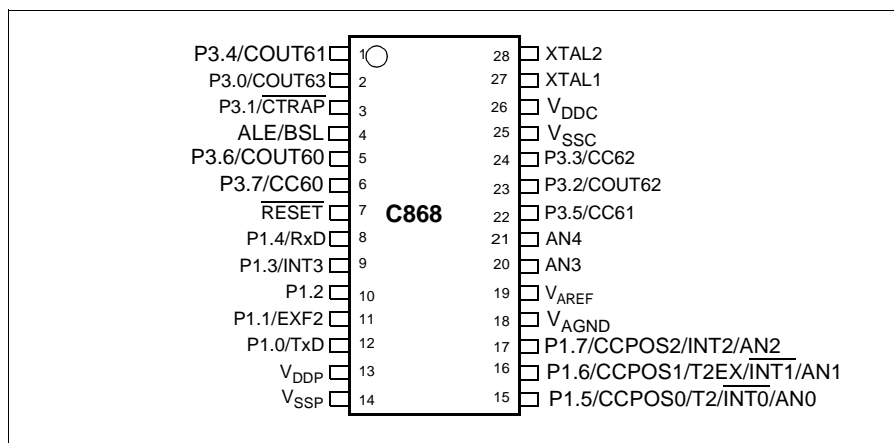

Figure 4 C868 Pin Configuration P-DSO-28 Package (top view)

Table 1 Pin Definitions and Functions

| Symbol | Pin Numbers | | I/O*) | Function |
|--------------------------------|--------------------------|-----------------------|--------------|--|
| | P-DSO-28 | P-TSSOP-38 | | |
| P1.0– P1.4 P1.5- P1.7 | 12-8 15-17 | 6,4-1 11-13 | I/O I | <p>Port 1 is a combination of 5 bits of push-pull bidirectional I/O ports and 3 bits of input ports. As alternate digital functions, port 1 contains the interrupt 3, timer 2 overflow flag, receive data input and transmit data output of serial interface. The alternate functions are assigned to the pins of port 1 as follows:</p> <p>P1.0/TxD Transmit data of serial interface P1.1/EXF2 Timer 2 overflow flag P1.2 P1.3/INT3 Interrupt 3 P1.4/RxD Receive data of serial interface, Use as wakeup source from powerdown if bit WS of PMCON0 is set.</p> <p>The input ports are also interrupt ports, input to the timer2, CCU6 modules and ADC:</p> <p>P1.5/Input to Counter 2/External Interrupt 0 Input/ Analog Input Channel 0 External interrupt input or Hall input signal, counter 2 input or input channel 0 to the ADC unit. Use as wakeup source from powerdown if bit WS of PMCON0 is cleared.</p> <p>P1.6/Timer 2 Trigger/External Interrupt 1 Input/ Analog Input Channel 1 External interrupt input or Hall input signal, input channel 1 to the ADC unit, trigger to Timer 2.</p> <p>P1.7/External Interrupt 2 Input/ Analog Input Channel 2 External interrupt input or Hall input signal and input channel 2 to the ADC unit.</p> |
| | 12 11 10 9 8 | 6 4 3 2 1 | | |
| | 15 | 11 | I | |
| | 16 | 12 | I | |
| | 17 | 13 | I | |

*)I=Input
O=Output

Table 1 Pin Definitions and Functions

| Symbol | Pin Numbers | | I/O*) | Function |
|-------------------|----------------------------|---------------------------------|-------|---|
| | P-DSO-28 | P-TSSOP-38 | | |
| P3.0– P3.7 | 2,3,23, 24,1, 22,5,6 | 32,33,25, 26,31,24, 36,37 | I/O | <p>Port 3 is an 8-bit push-pull bidirectional I/O port. This port also serves as alternate functions for the CCU6 functions. The functions are assigned to the pins of port 3 as follows :</p> <p>P3.0/COU63 16 bit compare channel output P3.1/CTRAP CCU trap input P3.2/COU62 Output of capture/compare ch 2 P3.3/CC62 Input/output of capture/compare ch 2 P3.4/COU61 Output of capture/compare ch 1 P3.5/CC61 Input/output of capture/compare ch 1 P3.6/COU60 Output of capture/compare ch 0 P3.7/CC60 Input/output of capture/compare ch 0</p> |
| V _{AREF} | 19 | 15 | – | Reference voltage for the A/D converter. |
| V _{AGND} | 18 | 14 | – | Reference ground for the A/D converter. |
| AN4 | 21 | 17 | I | Analog Input Channel 4 is input channel 4 to the ADC unit. |
| AN3 | 20 | 16 | I | Analog Input Channel 3 is input channel 3 to the ADC unit. |
| RESET | 7 | 38 | I | <p>RESET A low level on this pin for two machine cycle while the oscillator is running resets the device.</p> |
| ALE/BSL | 4 | 34 | I/O | <p>Address Latch Enable/Bootstrap Mode A low level on this pin during reset allows the device to go into the bootstrap mode. After reset, this pin will output the address latch enable signal. The ALE can be disabled by bit EALE in SFR SYSCON0.</p> |
| V _{SSP} | 14 | 10 | – | IO Ground (0V) |
| V _{DDP} | 13 | 9 | – | IO Power Supply (+3.3V) |

*)I=Input
O=Output

Table 1 Pin Definitions and Functions

| Symbol | Pin Numbers | | I/O*) | Function |
|------------------|-------------|----------------------------|-------|---|
| | P-DSO-28 | P-TSSOP-38 | | |
| V _{SSC} | 25 | 27 | – | Core Ground (0V) |
| V _{DDC} | 26 | 28 | O | Core Internal Reference (+2.5V) Connect 2*68 - 470nF ceramic capacitor across this pin and core ground. |
| NC | – | 5,7,8,18,19,20,21,22,23,35 | – | Not connected |
| XTAL1 | 27 | 29 | I | XTAL1 Output of the inverting oscillator amplifier. |
| XTAL2 | 28 | 30 | O | XTAL2 Input to the inverting oscillator amplifier and input to the internal clock generation circuits. To drive the device from an external clock source, XTAL2 should be driven, while XTAL1 is left unconnected. |

*)I=Input
O=Output

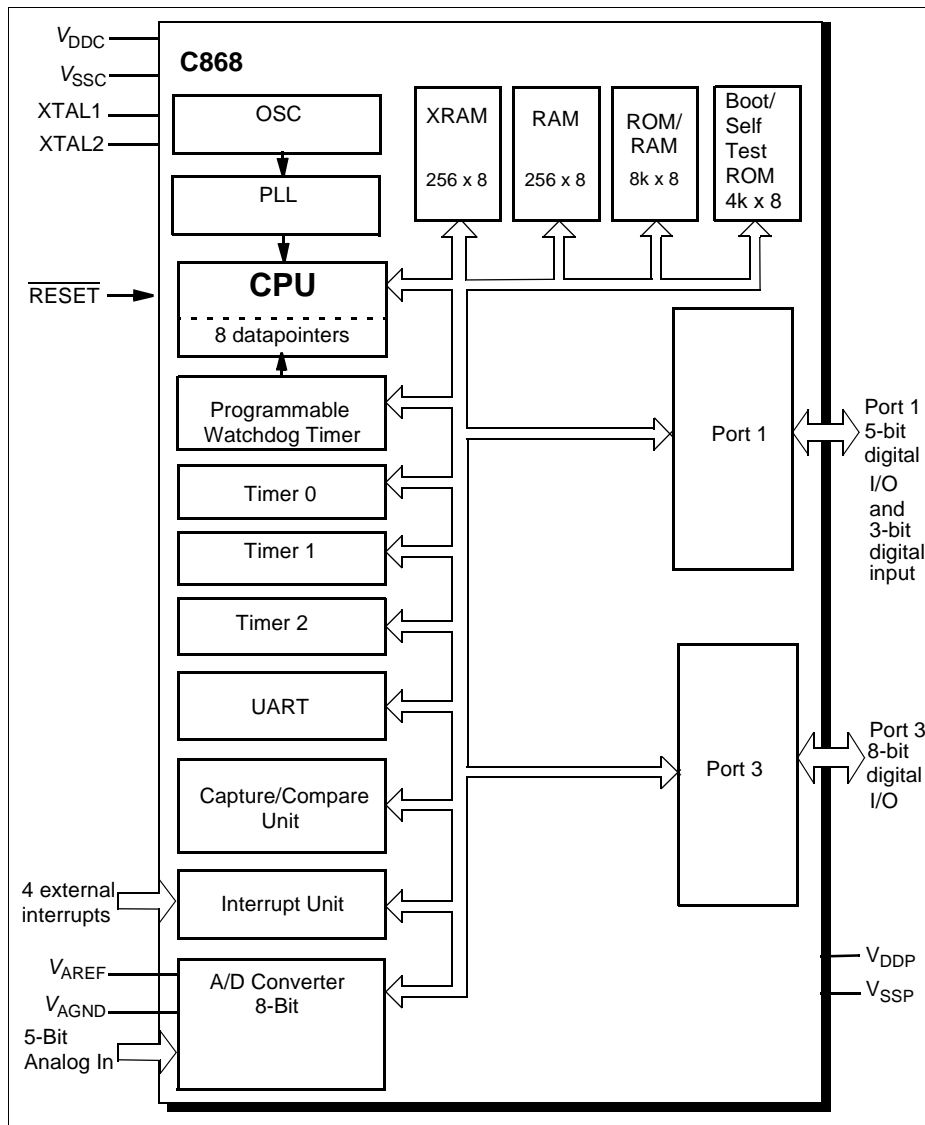

Figure 5 Block Diagram of the C868

CPU

The C868 is efficient both as a controller and as an arithmetic processor. It has extensive facilities for binary and BCD arithmetic and excels in its bit-handling capabilities. Efficient use of program memory results from an instruction set consisting of 44% one-byte, 41% two-byte, and 15% three-byte instructions. With a 10.67 MHz external crystal (giving a 40MHz CPU clock), 58% of the instructions execute in 300 ns.

PSW
Program Status Word Register
[Reset value: 00_H]

| | | | | | | | |
|-----------------|-----------------|-----------------|-----------------|-----------------|-----------------|-----------------|-----------------|
| D7 _H | D6 _H | D5 _H | D4 _H | D3 _H | D2 _H | D1 _H | D0 _H |
| CY | AC | F0 | RS1 | RS0 | OV | F1 | P |
| rwh | rwh | rw | rw | rw | rwh | rw | rwh |

| Field | Bits | Typ | Description | | | | | | | | | | | | | | | |
|--------------------------|--------|--|--|-----|-----|----------|---|---|--|---|---|--|---|---|--|---|---|--|
| P | 0 | rwh | Parity Flag Set/cleared by hardware after each instruction to indicate an odd/even number of "one" bits in the accumulator, i.e. even parity. | | | | | | | | | | | | | | | |
| F1 | 1 | rw | General Purpose Flag | | | | | | | | | | | | | | | |
| OV | 2 | rwh | Overflow Flag Used by arithmetic instructions. | | | | | | | | | | | | | | | |
| RS0 RS1 | 3 4 | rw | Register Bank select control bits These bits are used to select one of the four register banks. Table 2 : <table border="1" style="margin-left: 20px;"> <thead> <tr> <th>RS1</th> <th>RS0</th> <th>Function</th> </tr> </thead> <tbody> <tr> <td>0</td> <td>0</td> <td>Bank 0 selected, data address 00_H-07_H</td> </tr> <tr> <td>0</td> <td>1</td> <td>Bank 1 selected, data address 08_H-0F_H</td> </tr> <tr> <td>1</td> <td>0</td> <td>Bank 2 selected, data address 10_H-17_H</td> </tr> <tr> <td>1</td> <td>1</td> <td>Bank 3 selected, data address 18_H-1F_H</td> </tr> </tbody> </table> | RS1 | RS0 | Function | 0 | 0 | Bank 0 selected, data address 00 _H -07 _H | 0 | 1 | Bank 1 selected, data address 08 _H -0F _H | 1 | 0 | Bank 2 selected, data address 10 _H -17 _H | 1 | 1 | Bank 3 selected, data address 18 _H -1F _H |
| RS1 | RS0 | Function | | | | | | | | | | | | | | | | |
| 0 | 0 | Bank 0 selected, data address 00 _H -07 _H | | | | | | | | | | | | | | | | |
| 0 | 1 | Bank 1 selected, data address 08 _H -0F _H | | | | | | | | | | | | | | | | |
| 1 | 0 | Bank 2 selected, data address 10 _H -17 _H | | | | | | | | | | | | | | | | |
| 1 | 1 | Bank 3 selected, data address 18 _H -1F _H | | | | | | | | | | | | | | | | |
| F0 | 5 | rw | General Purpose Flag | | | | | | | | | | | | | | | |
| AC | 6 | rwh | Auxiliary Carry Flag Used by instructions which execute BCD operations. | | | | | | | | | | | | | | | |
| CY | 7 | rwh | Carry Flag Used by arithmetic instructions. | | | | | | | | | | | | | | | |

Memory Organization

The C868 CPU manipulates operands in the following five address spaces:

- up to 8 Kbyte of RAM internal program memory : 8K ROM for C868-1R
: 8K RAM for C868-1S
- 4 Kbyte of internal Self test and Boot ROM
- 256 bytes of internal data memory
- 256 bytes of internal XRAM data memory
- 128 byte special function register area

Figure 0-1 illustrates the memory address spaces of the C868.

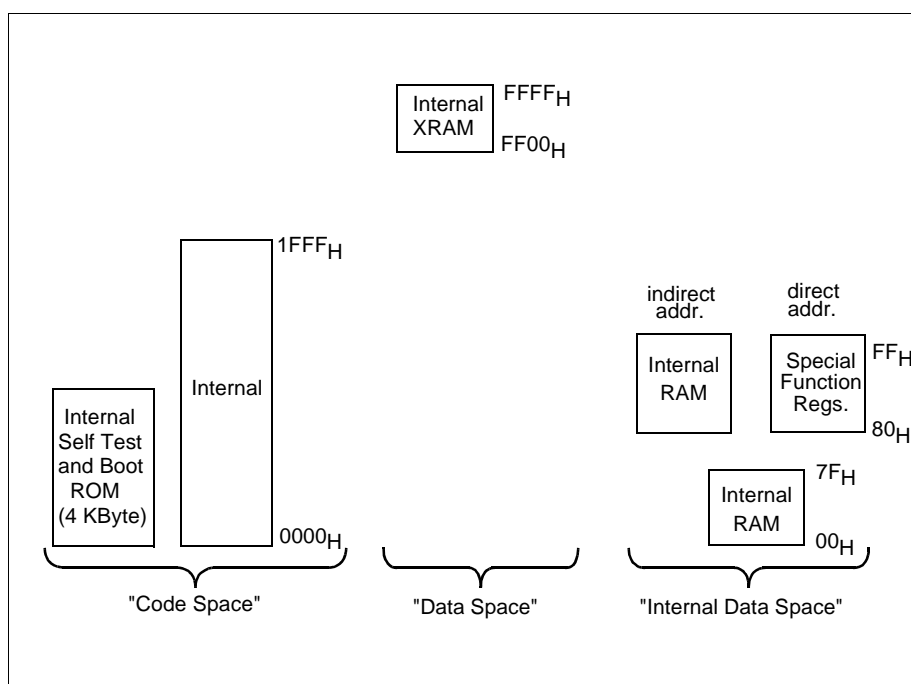

Figure 0-1 C868 Memory Map

The various chip modes supported are shown in [Figure 6](#).

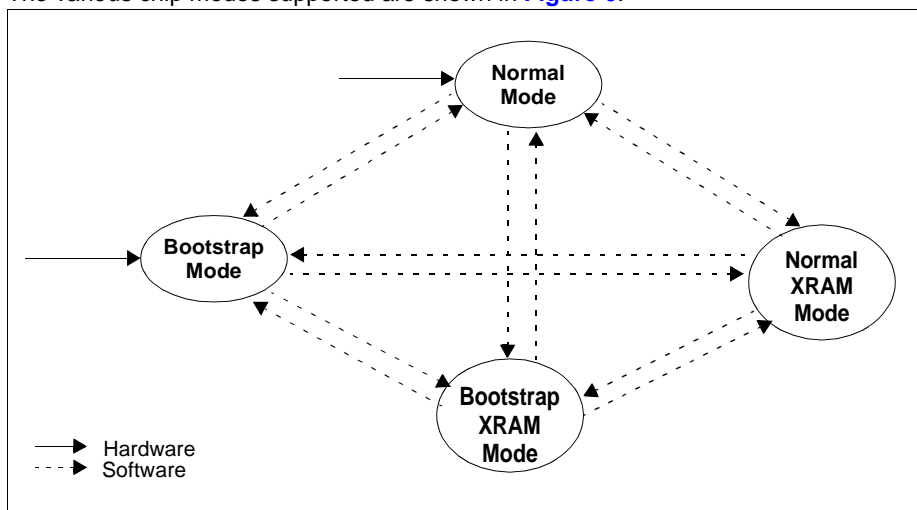

Figure 6 Entry and exit of Chip Modes

A valid hardware reset would, of course, override any of the above entry or exit procedures.

Table 0-1 Hardware and Software Selection of Chipmodes

| Operating Mode (Chipmode) | Hardware Selection | Software Selection |
|---------------------------|---|--|
| Normal Mode | ALE/BSL pin = high RESET rising edge | ALE/BSL = don't care; setting bits BSLEN, SWAP = 0,0; execute unlocking sequence |
| Normal XRAM Mode | Not possible | setting bits BSLEN,SWAP = 0,1; execute unlocking sequence |
| Bootstrap XRAM Mode | Not possible | setting bits BSLEN,SWAP = 1,1; execute unlocking sequence |
| Bootstrap Mode | ALE/BSL pin = low RESET rising edge | ALE/BSL = don't care; setting bits BSLEN, SWAP = 1,0; execute unlocking sequence |

Table 3 Normal Memory Configuration

| Chip Mode | Memory Space | Memory Boundary |
|----------------|---------------------|--|
| Normal | Code Space | ROM/RAM: 0000 _H to 1FFF _H |
| | Internal Data Space | XRAM: FF00 _H to FFFF _H |
| Bootstrap | Code Space | Boot ROM: 0000 _H to 0FFF _H |
| | Internal Data Space | XRAM: FF00 _H to FFFF _H ROM/RAM: 0000 _H to 1FFF _H |
| Normal XRAM | Code Space | XRAM: FF00 _H to FFFF _H |
| | Data Space | ROM/RAM: 0000 _H to 1FFF _H |
| Bootstrap XRAM | Code Space | Boot ROM: 0000 _H to 0FFF _H XRAM: FF00 _H to FFFF _H |
| | Data Space | ROM/RAM: 0000 _H to 1FFF _H |

Bootstrap loader

The C868, includes a bootstrap mode, which is activated by setting the ALE/BSL pin at logic low with a pulldown and TxD pin at logic high with a pullup at the rising edge of the $\overline{\text{RESET}}$. Or it can be entered by software, that is by setting BSLLEN bit and resetting SWAP bit in SFR SYSCON1 accompany by an unlock sequence.

In the bootstrap mode, software routines of the bootstrap loader located in the boot ROM will be executed. Its purpose is to allow the easy and quick programming of the internal SRAM (0000_H to 1FFF_H) or XRAM (FF00_H to FFFF_H) via serial interface (UART) while the MCU is in-circuit. It also provides a way to program SRAM or XRAM through bootstrapping from an external SPI or I2C EEPROM.

The first action of the bootstrap loader is to detect the presence of EEPROM and its type, SPI or I2C, and check the first byte of the serial EEPROM. If the first byte is 0A5_H, the MCU would enter Phase A to download from the EEPROM. Otherwise, it will enter Phase B to establish a serial communication with the connected host. Bootstrapping from the serial EEPROM can also be done in phase B if it is invoked by the host.

Phase B consists of two functional parts that represent two phases:

- Phase I: Establish a serial connection and automatically synchronize to the transfer speed (baud rate) of the serial communication partner (host).
- Phase II: Perform the serial communication with the host. The host controls the communication by sending special header information, which select one of the working modes. These modes are:

Table 4 Serial Communication Modes of Phase B

| Modes | Description |
|-------|--|
| 0 | Transfer a customer program from the host to the SRAM (0000 _H to 1FFF _H) or XRAM (FF00 _H -FFFF _H). Then return to the beginning of phase II and wait for the next command from the host. |
| 1 | Execute a customer program in the XRAM at start address FF00 _H . |
| 2 | Execute a customer program in the SRAM at start address 0000 _H . |
| 3 | Transfer a customer program from the SPI EEPROM to the SRAM (0000 _H to 1FFF _H) or XRAM (FF00 _H -FFFF _H). Then return to the beginning of phase II and wait for the next command from the host. |
| 4 | Transfer a customer program from the I2C EEPROM to the SRAM (0000 _H to 1FFF _H) or XRAM (FF00 _H -FFFF _H). Then return to the beginning of phase II and wait for the next command from the host. |
| 5-9 | reserved |

The phases of the bootstrap loader are illustrated in [Figure 7](#).

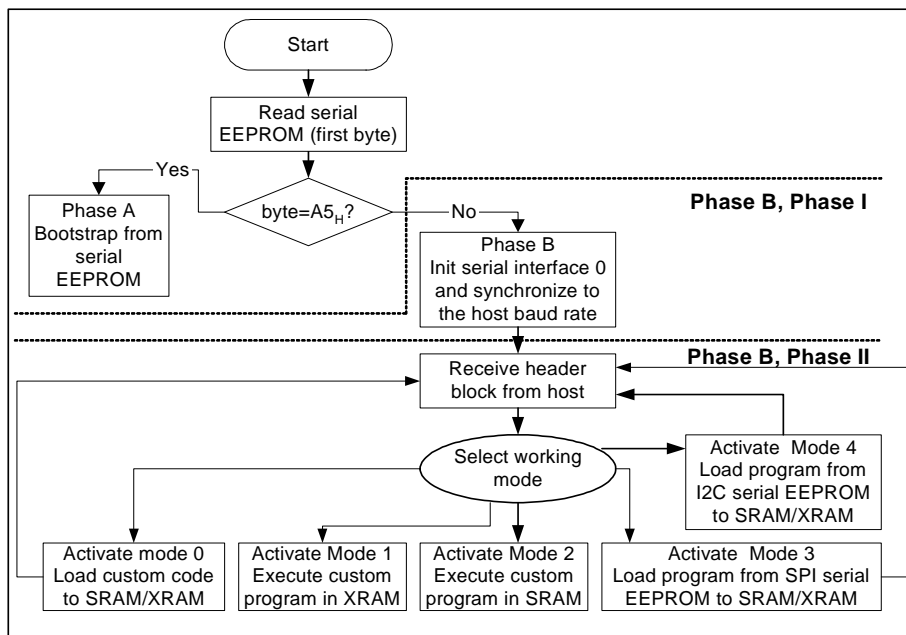

Figure 7 The phases of the Bootstrap Loader

The serial communication is activated in phase B. Using a full duplex serial cable (RS232), the MCU must be connected to the serial port of the host computer as shown in [Figure 8](#).

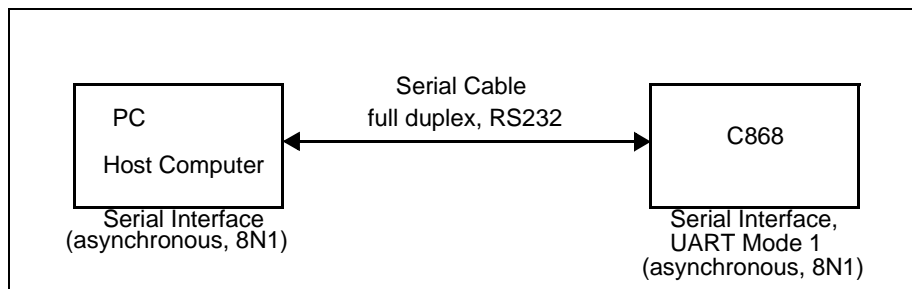

Figure 8 Bootstrap Loader Interface to the PC

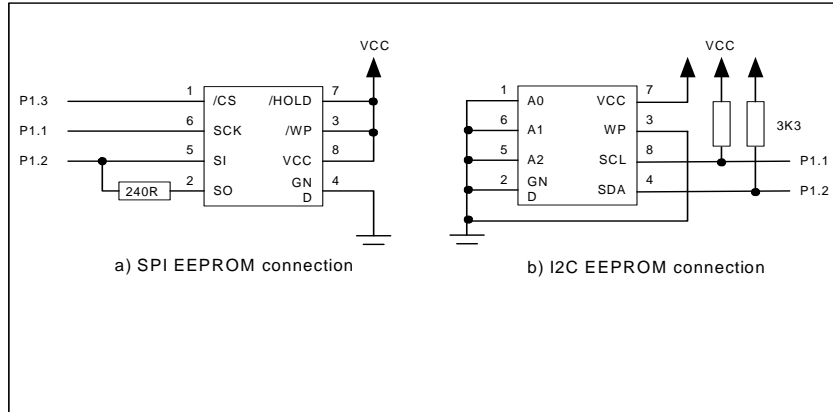

Figure 9 EEPROM connections for a) SPI and b) I2C

Reset and Brownout

The reset input is an active low input. An internal Schmitt trigger is used at the input for noise rejection. The $\overline{\text{RESET}}$ pin must be held low for at least tbd usec. But the CPU will only exit from reset condition after the PLL lock had been detected.

During $\overline{\text{RESET}}$ at transition from low to high, C868 will go into normal mode if ALE/BSL is high and bootstrap loading mode if ALE/BSL is low. A pullup to V_{DDP} or pulldown to ground is recommended for pin ALE/BSL. TXD should have a pullup to V_{DDP} and should not be stimulated externally during reset, as a logic low at this pin will cause the chip to go into test mode if ALE/BSL is low.

Figure 10 shows the possible reset circuits, note that the $\overline{\text{RESET}}$ pin does not have an internal pullup resistance.

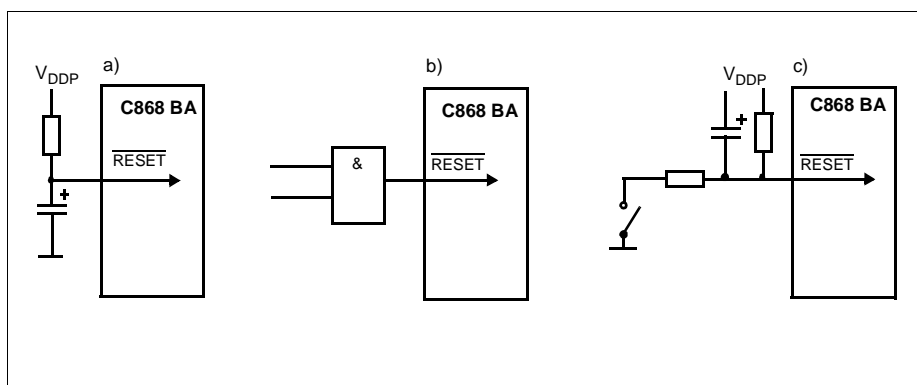

Figure 10 Reset Circuitries

An on-chip analog circuit detects brownout, if the core voltage V_{DDC} dips below the threshold voltage $V_{\text{THRESHOLD}}$ momentarily while $\overline{\text{RESET}}$ pin is high. If this detection is active for tbd usec then the device will reset. When V_{DDC} recovers by exceeding $V_{\text{THRESHOLD}}$ while $\overline{\text{RESET}}$ is high, the reset is released once PLL is locked for 4096 clocks. Bit BO in the PMCON0 register is set when brownout detected if brownout detection was enabled, this bit is cleared by hardware reset $\overline{\text{RESET}}$ and software. All ports are tristated during brownout.

The $V_{\text{THRESHOLD}}$ has a nominal value of 1.47V, a minimum value of 1.1V and a maximum value of 1.8V.

Clock system

The C868 clock system consist of the on-chip oscillator, PLL and multiplexer stage. The programmable Slow Down Divider (SDD) divides the PLL output clock frequency by a factor of 1...32 which is specified via CMCON.REL. The system clock is switched from the PLL output to the output from the SDD when slowdown mode is selected.

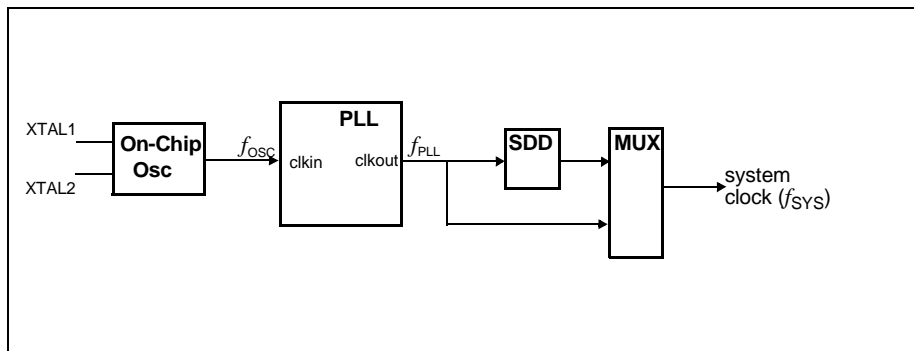

Figure 11 Block Diagram of the Clock Generation

The PLL output frequency is determined by:

$$f_{PLL} = f_{VCO} / K = \frac{15}{K} \times f_{OSC} \quad [1]$$

The range for the VCO frequency is given by:

$$100 \text{ MHz} \leq f_{VCO} \leq 160 \text{ MHz} \quad [2]$$

The relationship between the input frequency and VCO frequency is given by:

$$f_{VCO} = 15 \times f_{OSC} \quad [3]$$

This gives the range for the input frequency which is given by:

$$6.67 \text{ MHz} \leq f_{OSC} \leq 10.67 \text{ MHz} \quad [4]$$

Table 5 Output Frequencies f_{PLL} Derived from Various Output Factors

| K-Factor | | f_{PLL} | | Duty Cycle [%] | Jitter |
|-----------------|------------------|-----------------------------|-----------------------------|----------------|--|
| Selected Factor | KDIV | $f_{VCO} = 100 \text{ MHz}$ | $f_{VCO} = 160 \text{ MHz}$ | | |
| 2 | 000 _B | 50 | 80 | 50 | linear depending on f_{VCO} at $f_{VCO} = 100\text{MHz}$: +/-300ps at $f_{VCO} = 160\text{MHz}$: +/-250ps additional jitter for odd Kdiv factors tbd. |
| 4 | 010 _B | 25 | 40 | 50 | |
| 5 ¹⁾ | 011 _B | 20 | 32 | 40 | |
| 6 | 100 _B | 16.67 | 26.67 | 50 | |
| 8 | 101 _B | 12.5 | 20 | 50 | |
| 9 ¹⁾ | 110 _B | 11.11 | 17.78 | 44 | |
| 10 | 111 _B | 10 | 16 | 50 | |
| 16 | 001 _B | 6.25 | 10 | 50 | |

¹⁾ These odd factors should not be used (not tested because off the unsymmetrical duty cycle).

²⁾ Shaded combinations should not be used because they are above the maximum CPU frequency of 40MHz.

Figure 12 shows the recommended oscillator circuitries for crystal and external clock operation.

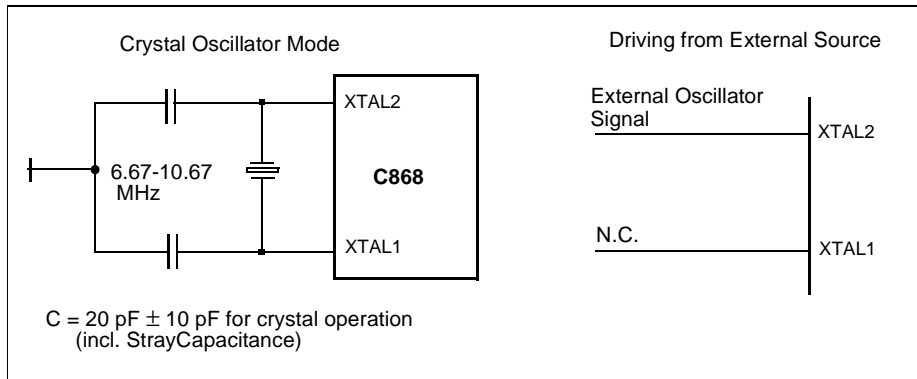

Figure 12 Recommended Oscillator Circuit

In this application the on-chip oscillator is used as a crystal-controlled, positive-reactance oscillator (a more detailed schematic is given in Figure 13). It is operated in its fundamental response mode as an inductive reactor in parallel resonance with a capacitor external to the chip. The crystal specifications and capacitances are non-critical. In this circuit 10 pF can be used as single capacitance at any frequency together with a good quality crystal. A ceramic resonator can be used in place of the crystal in cost-critical applications. If a ceramic resonator is used, the two capacitors normally have different values depending on the oscillator frequency. We recommend consulting the manufacturer of the ceramic resonator for value specifications of these capacitors.

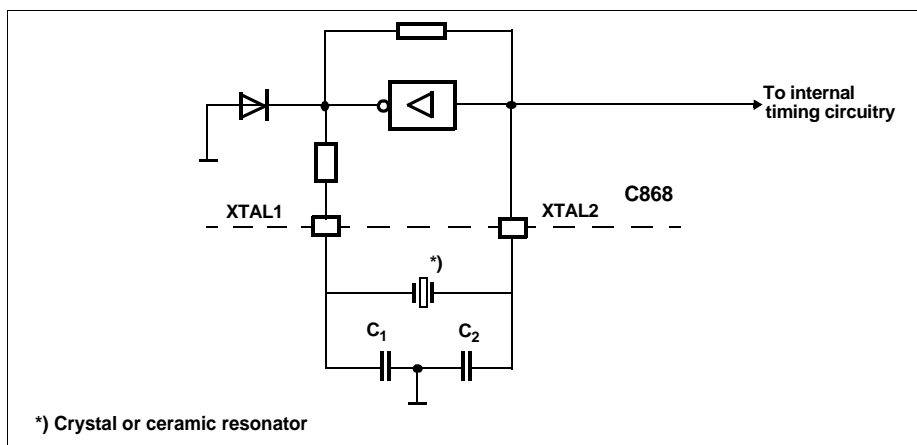

Figure 13 On-Chip Oscillator Circuitry

To drive the C868 with an external clock source, the external clock signal has to be applied to XTAL2, as shown in Figure 14. XTAL1 has to be left unconnected. A pullup resistor is suggested (to increase the noise margin), but is optional if V_{OH} of the driving gate corresponds to the V_{IH2} specification of XTAL2.

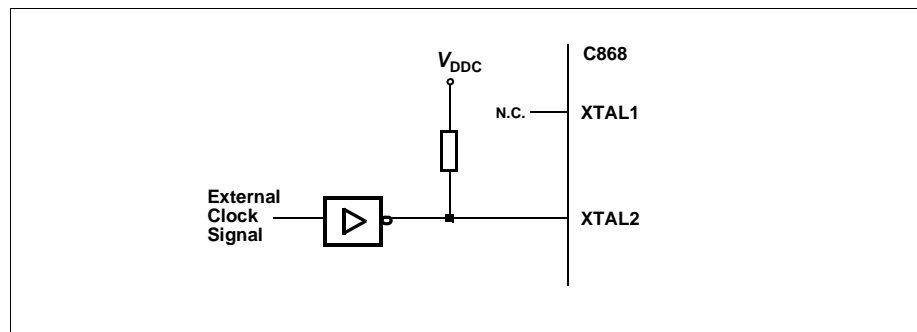

Figure 14 External Clock Source

0.1 Special Function Registers

All registers, except the program counter and the four general purpose register banks, reside in the special function register area. The special function register area consists of two portions: the standard special function register area and the mapped special function register area. For accessing the mapped special function area, bit RMAP in special function register SYSCON0 must be set. All other special function registers are located in the standard special function register area which is accessed when RMAP is cleared ("0").

SYSCON0

System Control Register 0

[Reset value: XX10XXX1_B]

| | | | | | | | |
|---|---|-------------|-------------|---|---|---|--------------|
| 7 | 6 | 5 | 4 | 3 | 2 | 1 | 0 |
| - | - | EALE | RMAP | - | - | - | XMAP0 |
| r | r | rw | rw | r | r | r | rw |



The functions of the shaded bits are not described here

| Field | Bits | Typ | Description |
|-------|-------|-----|---|
| RMAP | 4 | rw | Special Function Register Map Control RMAP = 0 : The access to the non-mapped (standard) special function register area is enabled. RMAP = 1 : The access to the mapped special function register area is enabled. |
| - | [7:2] | r | reserved; returns '0' if read; should be written with '0'; |

As long as bit RMAP is set, the mapped special function register area can be accessed. This bit is not cleared automatically by hardware. Thus, when non-mapped/mapped registers are to be accessed, the bit RMAP must be cleared/set respectively by software.

The 109 special function registers (SFR) include pointers and registers that provide an interface between the CPU and the other on-chip peripherals. All available SFRs whose address bits 0-2 are 0 (e.g. 80_H, 88_H, 90_H, ..., F0_H, F8_H) are bit-addressable. Totally there are 128 directly addressable bits within the SFR area.

All SFRs are listed in [Table 6](#) and [Table 7](#). In [Table 6](#) they are organized in groups which refer to the functional blocks of the C868-1R, C868-1S. [Table 7](#) illustrates the contents (bits) of the SFRs

Table 6 Special Function Registers - Functional Blocks

| Block | Symbol | Name | Address | Contents after Reset |
|-----------|---------------------------|---------------------------------------|-------------------------------------|---|
| C800 core | ACC | Accumulator | E0_H ¹⁾ | 00_H |
| | B | B-Register | F0_H ¹⁾ | 00_H |
| | DPH | Data Pointer, High Byte | 83 _H | 00 _H |
| | DPL | Data Pointer, Low Byte | 82 _H | 00 _H |
| | DPSEL | Data Pointer Select Register | 84 _H | 00 _H |
| | PSW | Program Status Word Register | D0_H ¹⁾ | 00_H |
| | SP | Stack Pointer | 81 _H | 07 _H |
| | SCON | Serial Channel Control Register | 98_H ¹⁾ | 00_H |
| | SBUF | Serial Data Buffer | 99 _H | 00 _H |
| | IEN0 | Interrupt Enable Register 0 | A8_H ¹⁾ | 0X000000_B ²⁾ |
| | IEN1 | Interrupt Enable Register 1 | A9 _H | XXXXXX000 _B ²⁾ |
| | IEN2 | Interrupt Enable Register 2 | AA _H | XX0000XX _B ²⁾ |
| | IP0 | Interrupt Priority Register 0 | B8_H ¹⁾ | XX000000_B ²⁾ |
| | IP1 | interrupt Priority Register 1 | AC _H | XX000000 _B ²⁾ |
| | TCON | Timer 0/1 Control Register | 88_H ¹⁾ | 00_H |
| | TMOD | Timer Mode Register | 89 _H | 00 _H |
| | TL0 | Timer 0, Low Byte | 8A _H | 00 _H |
| | TL1 | Timer 1, Low Byte | 8B _H | 00 _H |
| | TH0 | Timer 0, High Byte | 8C _H | 00 _H |
| | TH1 | Timer 1, High Byte | 8D _H | 00 _H |
| PCON | Power Control Register | 87 _H | 0XXX0000 _B ²⁾ | |
| System | PMCON0 | Wake-up Control Register | 8E _H | XXX00000 _B ²⁾ |
| | CMCON | Clock Control Register | 8F _H | 10011111 _B |
| | EXICON | External Interrupt Control Register | 91 _H | XXXXXX00 _B ²⁾ |
| | IRCON0 | External Interrupt Request Register | 92 _H | XXXXXX00 _B ²⁾ |
| | IRCON1 | Peripheral Interrupt Request Register | 93 _H | XX0000X0 _B ²⁾ |
| | PMCON1 | Peripheral Management Ctrl Register | E8_H ¹⁾ | XXXXX000_B ²⁾ |
| | PMCON2 | Peripheral Management Status Register | F8_H ¹⁾ | XXXXX000_B ²⁾ |
| | SCUWDT | SCU/Watchdog Control Register | C0_H ¹⁾ | X0X00000_B ²⁾ |
| | VERSION | ROM Version Register | F9 _H | 00 _H |
| | SYSCON0 | System Control Register 0 | AD _H | XX10XXX1 _B ²⁾ |
| SYSCON1 | System Control Register 1 | AF _H | 00XXX0X0 _B ²⁾ | |

1) Bit-addressable special function registers
 2) "X" means that the value is undefined and the location is reserved
 3) Register is mapped by bit RMAP in SYSCON0.4=1
 4) Register is mapped by bit RMAP in SYSCON0.4=0

Table 6 Special Function Registers - Functional Blocks (cont'd)

| Block | Symbol | Name | Address | Contents after Reset |
|---------------|---------------------|------------------------------------|-------------------------------------|--------------------------------------|
| A/D-Converter | ADCON0 | A/D Converter Control Register 0 | D8_H ¹⁾ | 00_H |
| | ADCON1 | A/D Converter Control Register 1 | D9 _H | XX000000 _B ²⁾ |
| | ADDATH | A/D Converter Data Register | DB _H | 00 _H |
| Ports | P1 ⁴⁾ | Port 1 Register | 90_H ¹⁾ | FF_H |
| | P1DIR ³⁾ | Port 1 Direction Register | 90_H ¹⁾ | FF_H |
| | P3 ⁴⁾ | Port 3 Register | B0_H ¹⁾ | FF_H |
| | P3DIR ³⁾ | Port 3 Direction Register | B0_H ¹⁾ | FF_H |
| | P3ALT | Port 3 Alternate Function Register | B1 _H | 00 _H |
| | P1ALT | Port 1 Alternate Function Register | B4 _H | XXX00X00 _B ²⁾ |
| Watchdog | WDTCON | Watchdog Timer Control Register | A2 _H | XXXXXX00 _B ²⁾ |
| | WDTREL | Watchdog Timer Reload Register | A3 _H | 00 _H |
| | WDTL | Watchdog Timer, Low Byte | B2 _H | 00 _H |
| | WDTH | Watchdog Timer, High Byte | B3 _H | 00 _H |
| Timer 2 | T2CON | Timer 2 Control Register | C8_H ¹⁾ | 00_H |
| | T2MOD | Timer 2 Mode Register | C9 _H | XXXXXXXX0 _B ²⁾ |
| | RC2H | Timer 2 Reload/Capture, High Byte | CB _H | 00 _H |
| | RC2L | Timer 2 Reload/Capture, Low Byte | CA _H | 00 _H |
| | T2H | Timer 2, High Byte | CD _H | 00 _H |
| | T2L | Timer 2, Low Byte | CC _H | 00 _H |

1) Bit-addressable special function registers

2) "X" means that the value is undefined and the location is reserved

3) Register is mapped by bit RMAP in SYSCON0.4=1

4) Register is mapped by bit RMAP in SYSCON0.4=0

Table 6 Special Function Registers - Functional Blocks (cont'd)

| Block | Symbol | Name | Address | Contents after Reset |
|----------------------|----------------------|---|-----------------|----------------------|
| Capture/Compare Unit | T12L | Timer T12 Counter Register, Low Byte | EC _H | 00 _H |
| | T12H | Timer T12 Counter Register, High Byte | ED _H | 00 _H |
| | T13L | Timer T13 Counter Register, Low Byte | EE _H | 00 _H |
| | T13H | Timer T13 Counter Register, High Byte | EF _H | 00 _H |
| | T12PRL | Timer T12 Period Register, Low Byte | DE _H | 00 _H |
| | T12PRH | Timer T12 Period Register, High Byte | DF _H | 00 _H |
| | T13PRL | Timer T13 Period Register, Low Byte | D2 _H | 00 _H |
| | T13PRH | Timer T13 Period Register, High Byte | D3 _H | 00 _H |
| | CC60RL | Capture/Compare Ch 0 Reg, Low Byte | C2 _H | 00 _H |
| | CC60RH | Capture/Compare Ch 0 Reg, High Byte | C3 _H | 00 _H |
| | CC61RL | Capture/Compare Ch 1 Reg, Low Byte | C4 _H | 00 _H |
| | CC61RH | Capture/Compare Ch 1 Reg, High Byte | C5 _H | 00 _H |
| | CC62RL | Capture/Compare Ch 2 Reg, Low Byte | C6 _H | 00 _H |
| | CC62RH | Capture/Compare Ch 2 Reg, High Byte | C7 _H | 00 _H |
| | CC63RL | T13 Compare Register, Low Byte | D4 _H | 00 _H |
| | CC63RH | T13 Compare Register, High Byte | D5 _H | 00 _H |
| | T12DTCL | Timer T12 Dead Time Ctrl, Low Byte | E6 _H | 00 _H |
| | T12DTCH | Timer T12 Dead Time Ctrl, High Byte | E7 _H | 00 _H |
| | CMPSTATL | Compare Timer Status, Low Byte | F4 _H | 00 _H |
| | CMPSTATH | Compare Timer Status, High Byte | F5 _H | 00 _H |
| | CMPMODIFL | Compare Timer Modification, Low Byte | EA _H | 00 _H |
| | CMPMODIFH | Compare Timer Modification, High Byte | EB _H | 00 _H |
| | TCTR0L | Timer Control Register 0, Low Byte | E2 _H | 00 _H |
| | TCTR0H | Timer Control Register 0, High Byte | E3 _H | 00 _H |
| | TCTR2L ³⁾ | Timer Control Register 2, Low Byte | F2 _H | 00 _H |
| | TCTR4L ⁴⁾ | Timer Control Register 4, Low Byte | F2 _H | 0 _H |
| | TCTR4H ⁴⁾ | Timer Control Register 4, High Byte | F3 _H | 00 _H |
| | ISL | Cap/Com Interrupt Register, Low Byte | E4 _H | 00 _H |
| | ISH | Cap/Com Interrupt Register, High Byte | E5 _H | 00 _H |
| | PISELH | Port Input Selector Register, High Byte | BB _H | 00 _H |

1) Bit-addressable special function registers
 2) "X" means that the value is undefined and the location is reserved
 3) Register is mapped by bit RMAP in SYSCON0.4=1
 4) Register is mapped by bit RMAP in SYSCON0.4=0

Table 6 Special Function Registers - Functional Blocks (cont'd)

| Block | Symbol | Name | Address | Contents after Reset |
|----------------------|------------------------|---|-----------------|----------------------|
| Capture/Compare Unit | ISSL ³⁾ | Cap/Com Int Status Set Reg, Low Byte | BC _H | 00 _H |
| | ISSH ³⁾ | Cap/Com Int Status Set Reg, High Byte | BD _H | 00 _H |
| | ISRL ⁴⁾ | Cap/Com Int Status Reset Reg, Low Byte | BC _H | 00 _H |
| | ISRH ⁴⁾ | Cap/Com Int Status Reset Reg, High Byte | BD _H | 00 _H |
| | INPL ³⁾ | Cap/Com Int Node Ptr Reg, Low Byte | BE _H | 40 _H |
| | INPH ³⁾ | Cap/Com Int Node Ptr Reg, High Byte | BF _H | 39 _H |
| | IENL ⁴⁾ | Cap/Com Interrupt Register, Low Byte | BE _H | 00 _H |
| | IENH ⁴⁾ | Cap/Com Interrupt Register, High Byte | BF _H | 00 _H |
| | CC60SRL | Cap/Com Channel 0 Shadow, Low Byte | FA _H | 00 _H |
| | CC60SRH | Cap/Com Channel 0 Shadow, High Byte | FB _H | 00 _H |
| | CC61SRL | Cap/Com Channel 1 Shadow, Low Byte | FC _H | 00 _H |
| | CC61SRH | Cap/Com Channel 1 Shadow, High Byte | FD _H | 00 _H |
| | CC62SRL | Cap/Com Channel 2 Shadow, Low Byte | FE _H | 00 _H |
| | CC62SRH | Cap/Com Channel 2 Shadow, High Byte | FF _H | 00 _H |
| | CC63SRL | T13 Compare Shadow Reg, Low Byte | B6 _H | 00 _H |
| | CC63SRH | T13 Compare Shadow Reg, High Byte | B7 _H | 00 _H |
| | MODCTRL ³⁾ | Modulation Control Register, Low Byte | D6 _H | 00 _H |
| | MODCTR ³⁾ | Modulation Control Register, High Byte | D7 _H | 00 _H |
| | TRPCTRL | Trap Control Register, Low Byte | CE _H | 00 _H |
| | TRPCTR ³⁾ | Trap Control Register, High Byte | CF _H | 00 _H |
| | PSLRL | Passive State Level Register, Low Byte | A6 _H | 00 _H |
| | MCMOUTL ³⁾ | MCM Output Register, Low Byte | DC _H | 00 _H |
| | MCMOUTH ³⁾ | MCM Output Register, High Byte | DD _H | 00 _H |
| | MCMOUTSL ⁴⁾ | MCM Output Shadow Register, Low Byte | DC _H | 00 _H |
| | MCMOUTSH ⁴⁾ | MCM Output Shadow Register, High Byte | DD _H | 00 _H |
| | MCMCTRL ⁴⁾ | MCM Control Register, Low Byte | D6 _H | 00 _H |
| | T12MSELL | T12 Cap/Com Mode Sel Reg, Low Byte | F6 _H | 00 _H |
| | T12MSELH | T12 Cap/Com Mode Sel Reg, High Byte | F7 _H | 00 _H |

1) Bit-addressable special function registers
 2) "X" means that the value is undefined and the location is reserved
 3) Register is mapped by bit RMAP in SYSCON0.4=1
 4) Register is mapped by bit RMAP in SYSCON0.4=0

Table 7 Contents of the SFRs, SFRs in numeric order of their addresses

| Addr | Register | Content after Reset ¹⁾ | Bit 7 | Bit 6 | Bit 5 | Bit 4 | Bit 3 | Bit 2 | Bit 1 | Bit 0 |
|-------------------------------|------------|-----------------------------------|-----------|-------|-------|-------|-----------|------------|------------|------------|
| 81 _H | SP | 07 _H | .7 | .6 | .5 | .4 | .3 | .2 | .1 | .0 |
| 82 _H | DPL | 00 _H | .7 | .6 | .5 | .4 | .3 | .2 | .1 | .0 |
| 83 _H | DPH | 00 _H | .7 | .6 | .5 | .4 | .3 | .2 | .1 | .0 |
| 84 _H | DPSE L | 00 _H | – | – | – | – | – | D2 | D1 | D0 |
| 87 _H | PCON | 0XX0 0000 _B | SMOD | – | – | SD | GF1 | GF0 | PDE | IDLE |
| 88 _H | TCON | 00 _H | TF1 | TR1 | TF0 | TR0 | IE1 | IT1 | IE0 | IT0 |
| 89 _H | TMOD | 00 _H | GATE 1 | C/NT1 | M1(1) | M0(1) | GATE 0 | C/NT0 | M1(0) | M0(0) |
| 8A _H | TL0 | 00 _H | .7 | .6 | .5 | .4 | .3 | .2 | .1 | .0 |
| 8B _H | TL1 | 00 _H | .7 | .6 | .5 | .4 | .3 | .2 | .1 | .0 |
| 8C _H | TH0 | 00 _H | .7 | .6 | .5 | .4 | .3 | .2 | .1 | .0 |
| 8D _H | TH1 | 00 _H | .7 | .6 | .5 | .4 | .3 | .2 | .1 | .0 |
| 8E _H | PMCO N0 | XXX0 0000 _B | – | – | – | EBO | BO | SDST AT | WS | EPWD |
| 8F _H | CMCO N | 1001 1111 _B | KDIV2 | KDIV1 | KDIV0 | REL4 | REL3 | REL2 | REL1 | REL0 |
| 90 _H ²⁾ | P1 | FF _H | .7 | .6 | .5 | .4 | .3 | .2 | .1 | .0 |
| 90 _H ³⁾ | P1DIR | FF _H | .7 | .6 | .5 | .4 | .3 | .2 | .1 | .0 |
| 91 _H | EXICO N | XXXX XX00 _B | – | – | – | – | – | – | ESEL3 | ESEL2 |
| 92 _H | IRCO N0 | XXXX XX00 _B | – | – | – | – | – | – | EXINT 3 | EXINT 2 |
| 93 _H | IRCO N1 | XX00 00X0 _B | – | – | INP3 | INP2 | INP1 | INP0 | – | IADC |
| 98 _H | SCON | 00 _H | SM0 | SM1 | SM2 | REN | TB8 | RB8 | TI | RI |
| 99 _H | SBUF | 00 _H | .7 | .6 | .5 | .4 | .3 | .2 | .1 | .0 |

1) X means that the value is undefined and the location is reserved

2) This register is mapped with RMAP (SYSCON.4)=0

3) This register is mapped with RMAP (SYSCON.4)=1

Shaded registers are bit-addressable special function registers

Table 7 Contents of the SFRs, SFRs in numeric order of their addresses

| Addr | Register | Content after Reset ¹⁾ | Bit 7 | Bit 6 | Bit 5 | Bit 4 | Bit 3 | Bit 2 | Bit 1 | Bit 0 |
|-------------------------------|-------------|-----------------------------------|-------|------------|-------|------------|-------|------------|-----------|------------|
| A2 _H | WDTON | XXXX XX00 _B | – | – | – | – | – | – | – | WDI N |
| A3 _H | WDREL | 00 _H | .7 | .6 | .5 | .4 | .3 | .2 | .1 | .0 |
| A6 _H | PSLRL | 00 _H | PSL63 | – | PSL5 | PSL4 | PSL3 | PSL2 | PSL1 | PSL0 |
| A8 _H | IEN0 | 0X00 0000 _B | EA | – | ET2 | ES | ET1 | EX1 | ET0 | EX0 |
| A9 _H | IEN1 | XXXX X000 _B | – | – | – | – | – | EX3 | EX2 | EADC |
| AA _H | IEN2 | XX00 00XX _B | – | – | EINP3 | EINP2 | EINP1 | EINP0 | – | – |
| AC _H | IP1 | XX00 0000 _B | – | – | .5 | .4 | .3 | .2 | .1 | .0 |
| AD _H | SYSCON0 | XX10 XXX1 _B | – | – | EALE | RMAP | – | – | – | XMAP 0 |
| AF _H | SYSCON1 | 00XX X0X0 _B | ESWC | SWC | – | – | – | BSLE N | – | SWAP |
| B0 _H ²⁾ | P3 | FF _H | .7 | .6 | .5 | .4 | .3 | .2 | .1 | .0 |
| B0 _H ³⁾ | P3DIR | FF _H | .7 | .6 | .5 | .4 | .3 | .2 | .1 | .0 |
| B1 _H | P3ALT | 00 _H | CC60 | COUT 60 | CC61 | COUT 61 | CC62 | COUT 62 | CTRA P | COUT 63 |
| B2 _H | WDTL | 00 _H | .7 | .6 | .5 | .4 | .3 | .2 | .1 | .0 |
| B3 _H | WDTH | 00 _H | .7 | .6 | .5 | .4 | .3 | .2 | .1 | .0 |
| B4 _H | P1ALT | XXX0 0X00 _B | – | – | – | RxD | INT3 | – | EXF2 | TxD |
| B6 _H | CC63 SRL | 00 _H | .7 | .6 | .5 | .4 | .3 | .2 | .1 | .0 |
| B7 _H | CC63 SRH | 00 _H | .7 | .6 | .5 | .4 | .3 | .2 | .1 | .0 |

1) X means that the value is undefined and the location is reserved

2) This register is mapped with RMAP (SYSCON0.4)=0

3) This register is mapped with RMAP (SYSCON0.4)=1

Shaded registers are bit-addressable special function registers

Table 7 Contents of the SFRs, SFRs in numeric order of their addresses

| Addr | Register | Content after Reset ¹⁾ | Bit 7 | Bit 6 | Bit 5 | Bit 4 | Bit 3 | Bit 2 | Bit 1 | Bit 0 |
|-------------------------------|------------|-----------------------------------|--------------|--------------|---------------|---------------|---------------|---------------|---------------|---------------|
| B8 _H | IPO | XX00 0000 _B | – | – | .5 | .4 | .3 | .2 | .1 | .0 |
| BB _H | PISEL H | 00 _H | – | – | ISPOS 2.1 | ISPOS 2.0 | ISPOS 1.1 | ISPOS 1.0 | ISPOS 0.1 | ISPOS 0.0 |
| BC _H ³⁾ | ISSL | 00 _H | ST12P M | ST12O M | SCC62 F | SCC62 R | SCC61 F | SCC61 R | SCC60 F | SCC60 R |
| BC _H ²⁾ | ISRL | 00 _H | RT12P M | RT12O M | RCC6 2F | RCC6 2R | RCC6 1F | RCC6 1R | RCC6 0F | RCC6 0R |
| BD _H ³⁾ | ISSH | 00 _H | – | SIDLE | SWHE | SCHE | – | STRP F | ST13P M | ST13C M |
| BD _H ²⁾ | ISRH | 00 _H | – | RIDLE | RWHE | RCHE | – | RTRP F | RT13P M | RT13C M |
| BE _H ²⁾ | IENL | 00 _H | ENT12 PM | ENT12 OM | ENCC 62F | ENCC 62R | ENCC 61F | ENCC 61R | ENCC 60F | ENCC 60R |
| BE _H ³⁾ | INPL | 00 _H | INPCH E.1 | INPCH E.0 | INPCC 62.1 | INPCC 62.0 | INPCC 61.1 | INPCC 61.0 | INPCC 60.1 | INPCC 60.0 |
| BF _H ²⁾ | IENH | 00 _H | – | ENIDL E | ENWH E | ENCH E | – | ENTR PF | ENT13 PM | ENT13 CM |
| BF _H ³⁾ | INPH | 00 _H | – | – | INPT1 3.1 | INPT1 3.0 | INPT1 2.1 | INPT1 2.0 | INPER R.1 | INPER R.0 |
| C0 _H | SCUW DT | 00 _H | – | PLL R | – | WDTR | WDTE OI | WDTD IS | WDTR S | WDTR E |
| C2 _H | CC60 RL | 00 _H | .7 | .6 | .5 | .4 | .3 | .2 | .1 | .0 |
| C3 _H | CC60 RH | 00 _H | .7 | .6 | .5 | .4 | .3 | .2 | .1 | .0 |
| C4 _H | CC61 RL | 00 _H | .7 | .6 | .5 | .4 | .3 | .2 | .1 | .0 |
| C5 _H | CC61 RH | 00 _H | .7 | .6 | .5 | .4 | .3 | .2 | .1 | .0 |

1) X means that the value is undefined and the location is reserved

2) This register is mapped with RMAP (SYSCON0.4)=0

3) This register is mapped with RMAP (SYSCON0.4)=1

Shaded registers are bit-addressable special function registers

Table 7 Contents of the SFRs, SFRs in numeric order of their addresses

| Addr | Register | Content after Reset ¹⁾ | Bit 7 | Bit 6 | Bit 5 | Bit 4 | Bit 3 | Bit 2 | Bit 1 | Bit 0 |
|-------------------------------|-----------|-----------------------------------|---------|---------|------------|------------|------------|------------|----------------|------------|
| C6 _H | CC62 RL | 00 _H | .7 | .6 | .5 | .4 | .3 | .2 | .1 | .0 |
| C7 _H | CC62 RH | 00 _H | .7 | .6 | .5 | .4 | .3 | .2 | .1 | .0 |
| C8 _H | T2CON | 00 _H | TF2 | EXF2 | RCLK | TCLK | EXEN2 | TR2 | C/ \bar{T} 2 | CP/RL2 |
| C9 _H | T2MOD | XXXX XXX0 _B | – | – | – | – | – | – | – | DCEN |
| CA _H | RC2L | 00 _H | .7 | .6 | .5 | .4 | .3 | .2 | .1 | .0 |
| CB _H | RC2H | 00 _H | .7 | .6 | .5 | .4 | .3 | .2 | .1 | .0 |
| CC _H | TL2 | 00 _H | .7 | .6 | .5 | .4 | .3 | .2 | .1 | .0 |
| CD _H | TH2 | 00 _H | .7 | .6 | .5 | .4 | .3 | .2 | .1 | .0 |
| CE _H | TRPC TRL | 00 _H | – | – | – | – | – | TRPM2 | TRPM1 | TRPM0 |
| CF _H | TRPC TRH | 00 _H | TRPP EN | TRPEN13 | TRPEN5 | TRPEN4 | TRPEN3 | TRPEN2 | TRPEN1 | TRPEN0 |
| D0 _H | PSW | 00 _H | CY | AC | F0 | RS1 | RS0 | OV | F1 | P |
| D2 _H | T13PRL | 00 _H | .7 | .6 | .5 | .4 | .3 | .2 | .1 | .0 |
| D3 _H | T13PRH | 00 _H | .7 | .6 | .5 | .4 | .3 | .2 | .1 | .0 |
| D4 _H | CC63 RL | 00 _H | .7 | .6 | .5 | .4 | .3 | .2 | .1 | .0 |
| D5 _H | CC63 RH | 00 _H | .7 | .6 | .5 | .4 | .3 | .2 | .1 | .0 |
| D6 _H ²⁾ | MCMC TRLL | 00 _H | – | – | SWSYN1 | SWSYN0 | – | SWSEL2 | SWSEL1 | SWSEL0 |
| D6 _H ³⁾ | MODC TRL | 00 _H | MCME N | – | T12M ODEN5 | T12M ODEN4 | T12M ODEN3 | T12M ODEN2 | T12M ODEN1 | T12M ODEN0 |

1) X means that the value is undefined and the location is reserved

2) This register is mapped with RMAP (SYSCON0.4)=0

3) This register is mapped with RMAP (SYSCON0.4)=1

Shaded registers are bit-addressable special function registers

Table 7 Contents of the SFRs, SFRs in numeric order of their addresses

| Addr | Register | Content after Reset ¹⁾ | Bit 7 | Bit 6 | Bit 5 | Bit 4 | Bit 3 | Bit 2 | Bit 1 | Bit 0 |
|-------------------------------|----------------------|-----------------------------------|--------|-------|------------|------------|------------|------------|------------|------------|
| D7 _H ³⁾ | MODCTR | 00 _H | ECT13O | – | T13M ODEN5 | T13M ODEN4 | T13M ODEN3 | T13M ODEN2 | T13M ODEN1 | T13M ODEN0 |
| D8 _H | ADCON0 | 00 _H | ADST | ADBSY | ADM1 | ADM0 | CCU-ADEX | ADCH2 | ADCH1 | ADCH0 |
| D9 _H | ADCON1 | XX000000 _B | – | – | ADSTC2 | ADSTC1 | ADSTC0 | ADCTC2 | ADCTC1 | ADCTC0 |
| DB _H | ADDA _{TH} | 00 _H | .7 | .6 | .5 | .4 | .3 | .2 | .1 | .0 |
| DC _H ³⁾ | MCMP _{UTL} | 00 _H | – | R | MCMP5 | MCMP4 | MCMP3 | MCMP2 | MCMP1 | MCMP0 |
| DC _H ²⁾ | MCMP _{UTSL} | 00 _H | STRMCM | – | MCMP5S | MCMP4S | MCMP3S | MCMP2S | MCMP1S | MCMP0S |
| DD _H ³⁾ | MCMP _{UTH} | 00 _H | – | – | CURH2 | CURH1 | CURH0 | EXPH2 | EXPH1 | EXPH0 |
| DD _H ²⁾ | MCMP _{UTSH} | 00 _H | STRHP | – | CURH2S | CURH1S | CURH0S | EXPH2S | EXPH1S | EXPH0S |
| DE _H | T12PRL | 00 _H | .7 | .6 | .5 | .4 | .3 | .2 | .1 | .0 |
| DF _H | T12PRH | 00 _H | .7 | .6 | .5 | .4 | .3 | .2 | .1 | .0 |
| E0 _H | ACC | 00 _H | .7 | .6 | .5 | .4 | .3 | .2 | .1 | .0 |
| E2 _H | TCTR _{OL} | 00 _H | CTM | CDIR | STE12 | T12R | T12PRE | T12CLK2 | T12CLK1 | T12CLK0 |
| E3 _H | TCTR _{OH} | 10 _H | – | – | STE13 | T13R | T13PRE | T13CLK2 | T13CLK1 | T13CLK0 |
| E4 _H | ISL | 00 _H | T12PM | T12OM | ICC62F | ICC62R | ICC61F | ICC61R | ICC60F | ICC60R |
| E5 _H | ISH | 00 _H | – | IDLE | WHE | CHE | TRPS | TRPF | T13PM | T13CM |

1) X means that the value is undefined and the location is reserved

2) This register is mapped with RMAP (SYSCON0.4)=0

3) This register is mapped with RMAP (SYSCON0.4)=1

Shaded registers are bit-addressable special function registers

Table 7 Contents of the SFRs, SFRs in numeric order of their addresses

| Addr | Register | Content after Reset ¹⁾ | Bit 7 | Bit 6 | Bit 5 | Bit 4 | Bit 3 | Bit 2 | Bit 1 | Bit 0 |
|-------------------------------|-----------|-----------------------------------|----------|-----------|-----------|----------|-----------|----------|-----------|----------|
| E6 _H | T12DTCL | 00 _H | | – | DTM5 | DTM4 | DTM3 | DTM2 | DTM1 | DTM0 |
| E7 _H | T12DTC | 00 _H | – | DTR2 | DTR1 | DTR0 | – | DTE2 | DTE1 | DTE0 |
| E8 _H | PMCON1 | XXXXX000 _B | – | – | – | – | – | CCUDIS | T2DIS | ADCDIS |
| EA _H | CMPMODIFL | 00 _H | – | MCC63S | – | – | – | MCC62S | MCC61S | MCC60S |
| EB _H | CMPMODIFH | 00 _H | – | MCC63R | – | – | – | MCC62R | MCC61R | MCC60R |
| EC _H | T12L | 00 _H | .7 | .6 | .5 | .4 | .3 | .2 | .1 | .0 |
| ED _H | T12H | 00 _H | .7 | .6 | .5 | .4 | .3 | .2 | .1 | .0 |
| EE _H | T13L | 00 _H | .7 | .6 | .5 | .4 | .3 | .2 | .1 | .0 |
| EF _H | T13H | 00 _H | .7 | .6 | .5 | .4 | .3 | .2 | .1 | .0 |
| F0 _H | B | 00 _H | .7 | .6 | .5 | .4 | .3 | .2 | .1 | .0 |
| F2 _H ²⁾ | TCTR4L | 00 _H | T12STD | T12STR | – | – | DTRES | T12RES | T12RS | T12RR |
| F2 _H ³⁾ | TCTR2L | 00 _H | – | T13TE D1 | T13TE D0 | T13TE C2 | T13TE C1 | T13TE C0 | T13SS C | T12SS C |
| F3 _H ²⁾ | TCTR4H | 00 _H | T13STD | T13STR | – | – | – | T13RES | T13RS | T13RR |
| F4 _H | CMPS TATL | 00 _H | – | CC63S T | – | – | – | CC62S T | CC61S T | CC60S T |
| F5 _H | CMPS TATH | 00 _H | T13IM | COU T63PS | COU T62PS | CC62P S | COU T61PS | CC61P S | COU T60PS | CC60P S |
| F6 _H | T12M SELL | 00 _H | MSEL 613 | MSEL 612 | MSEL 611 | MSEL 610 | MSEL 603 | MSEL 602 | MSEL 601 | MSEL 600 |
| F7 _H | T12M SELH | 00 _H | – | – | – | – | MSEL 623 | MSEL 622 | MSEL 621 | MSEL 620 |

1) X means that the value is undefined and the location is reserved

2) This register is mapped with RMAP (SYSCON0.4)=0

3) This register is mapped with RMAP (SYSCON0.4)=1

Shaded registers are bit-addressable special function registers

Table 7 Contents of the SFRs, SFRs in numeric order of their addresses

| Addr | Register | Content after Reset ¹⁾ | Bit 7 | Bit 6 | Bit 5 | Bit 4 | Bit 3 | Bit 2 | Bit 1 | Bit 0 |
|-----------------|------------|-----------------------------------|-------|-------|-------|-------|-------|-------|-------|-----------|
| F8 _H | PMCON2 | XXXX X000 _B | – | – | – | – | – | CCUST | T2ST | ADCS T |
| F9 _H | VERSION | 00 _H | PROT | VER6 | VER5 | VER4 | VER3 | VER2 | VER1 | VER0 |
| FA _H | CC60 RL | 00 _H | .7 | .6 | .5 | .4 | .3 | .2 | .1 | .0 |
| FB _H | CC60 RH | 00 _H | .7 | .6 | .5 | .4 | .3 | .2 | .1 | .0 |
| FC _H | CC61 RL | 00 _H | .7 | .6 | .5 | .4 | .3 | .2 | .1 | .0 |
| FD _H | CC61 RH | 00 _H | .7 | .6 | .5 | .4 | .3 | .2 | .1 | .0 |
| FE _H | CC62 RL | 00 _H | .7 | .6 | .5 | .4 | .3 | .2 | .1 | .0 |
| FF _H | CC62 RH | 00 _H | .7 | .6 | .5 | .4 | .3 | .2 | .1 | .0 |

1) X means that the value is undefined and the location is reserved

2) This register is mapped with RMAP (SYSCON0.4)=0

3) This register is mapped with RMAP (SYSCON0.4)=1

Shaded registers are bit-addressable special function registers

Ports

The C868 has two kinds of ports. The first kind is push-pull ports instead of the traditional quasi-bidirectional ports. The ports belonging to this kind are lsb of port 1 which is a 5-bit I/O port and port 3 which is an eight-bit I/O port. When configured as inputs, these ports will be high impedance with Schmitt trigger feature. Port 3 is alternate for capture/compare functions whereas, port 1 has alternate functions for some of the pins.

The second kind is input ports which are shared by msb of port 1 which is a 3-bit input port, the interrupts, timer 2 inputs, capture/compare hall inputs and analog inputs.

Timer 0 and 1

Timer 0 and 1 can be used in four operating modes as listed in [Table 8](#):

Table 8 Timer 0 and 1 Operating Modes

| Mode | Description | TMOD | | System Clock |
|------|--|------|----|-------------------|
| | | M1 | M0 | |
| 0 | 8-bit timer with a divide-by-32 prescaler | 0 | 0 | $f_{SYS}/(12*32)$ |
| 1 | 16-bit timer | 0 | 1 | $f_{SYS}/12$ |
| 2 | 8-bit timer with 8-bit autoreload | 1 | 0 | |
| 3 | Timer 0 used as one 8-bit timer and one 8-bit timer timer 1 stops | 1 | 1 | |

The register is incremented every machine cycle. Since the machine cycle consist of twelve oscillator periods, the count rate is 1/12th of the system frequency. External inputs $\overline{INT0}$ and $\overline{INT1}$ can be programmed to function as a gate to facilitate pulse width measurements. [Figure 15](#) illustrates the input clock logic.

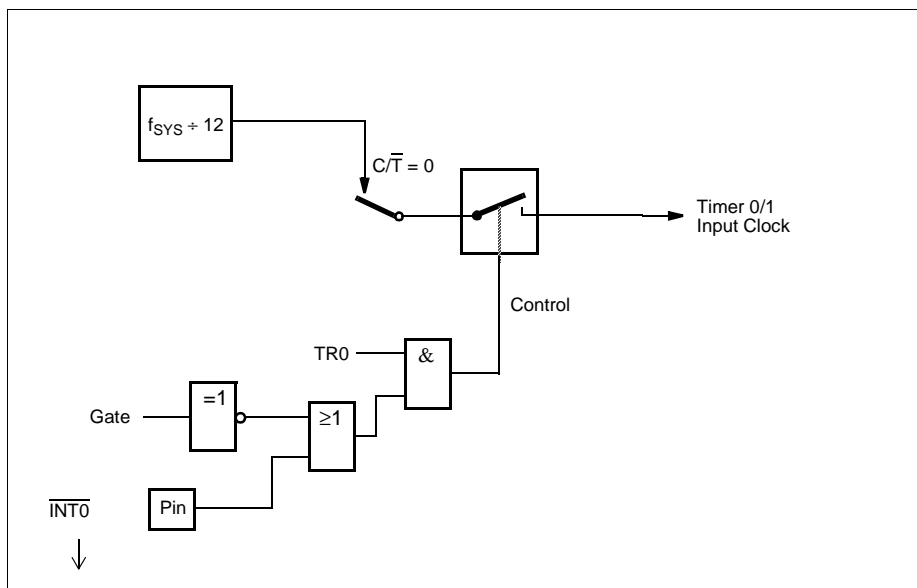

Figure 15 Timer 0 and 1 Input Clock Logic

Timer/Counter 2 with Compare/Capture/Capture

Timer 2 is a 16-bit timer/counter with an up/down count feature. It has three operating modes:

- 16-bit auto-reload mode (up or down counting)
- 16-bit capture mode
- Baudrate generator

Table 9 Timer/Counter 2 Operating Modes

| Mode | T2CON | | | T2MOD | T2CON | T2EX | Remarks | System Clock | |
|--------------------|--------------------|------------|-----|-------|-------|------|---|--------------|---------------------|
| | RCLK or TCLK | CP/ RL2 | TR2 | DCEN | EXEN | | | Internal | T2 |
| 16-bit Auto-reload | 0 | 0 | 1 | 0 | 0 | X | reload upon overflow | $f_{SYS}/12$ | max $f_{SYS}/24$ |
| | 0 | 0 | X | 0 | 1 | ↓ | reload trigger (falling edge) | | |
| | 0 | 0 | 1 | 1 | X | 0 | down counting | | |
| | 0 | 0 | 1 | 1 | X | 1 | up counting | | |
| 16-bit Capture | 0 | 1 | 1 | X | 0 | X | 16-bit Timer/Counter (only up-counting) | $f_{SYS}/12$ | max $f_{SYS}/24$ |
| | 0 | 1 | 1 | X | 1 | ↓ | capture T2H,T2L->RC2H,RC2L | | |
| Baudrate Generator | 1 | X | 1 | X | 0 | X | no overflow interrupt request(TF2) | $f_{SYS}/2$ | - |
| | 1 | X | 1 | X | 1 | ↓ | extra external interrupt ("Timer 2") | | |
| off | X | X | 0 | X | X | X | Timer 2 stops | - | - |

Note: ↓ denotes a falling edge

Serial Interface (UART)

The serial port is a full duplex port capable of simultaneous transmit and receive functions. It is also receive-buffered; it can commence reception of a second byte before a previously-received byte has been read from the receive register. The serial port can operate in 3 modes as illustrated in [Table 10](#).

Table 10 **UART Operating Modes**

| Mode | SCON | | Description |
|------|------|-----|--|
| | SM1 | SM0 | |
| 0 | 0 | 0 | Reserved |
| 1 | 0 | 1 | 8-bit UART, variable baudrate 10 bits are transmitted (through TxD) or received (RxD) |
| 2 | 1 | 0 | 9-bit UART, fixed baudrate 11 bits are transmitted (through TxD) or received (RxD) |
| 3 | 1 | 1 | 9-bit UART, variable baudrate Similar to mode 2, except for the variable baudrate. |

For clarification, some terms regarding the difference between “baudrate clock“ and “baudrate“ should be mentioned.

The serial interface requires a clock rate which is 16 times the baudrate for internal synchronization. Therefore, the baudrate generators must provide a “baudrate clock“ to the serial interface which divides it by 16, thereby resulting in the actual “baudrate“.

The baudrates in Mode 1 and 3 are determined by the timer overflow rate. These baudrates can be determined by Timer 1 or by Timer 2 or both (one for transmit, the other for receive).

Table 11 Serial Interface - Baud Rate Dependencies

| Serial Interface Operating Modes | Active Control Bits | | Baud Rate Calculation |
|--|---------------------|------|---|
| | TCLK/ RCLK | SMOD | |
| Mode 1 (8-bit UART) Mode 3 (9-bit UART) | 0 | x | Controlled by timer 1 overflow: $(2^{\text{SMOD}} \times \text{Timer 1 overflow rate}) / 32$ |
| | 1 | x | Controlled by baud rate generator $(2^{\text{SMOD}} \times \text{Timer 2}^{1}) \text{ overflow rate} / 32$ |
| Mode 2 (9-bit UART) | – | 0 | $f_{\text{SYS}} / 64$ |
| | | 1 | $f_{\text{SYS}} / 32$ |

¹⁾ Timer 2 functioning as baudrate generator

Capture/Compare Unit (CCU6)

The CCU6 provides two independent timers (T12, T13), which can be used for PWM generation, especially for AC-motor control. Additionally, special control modes for block commutation and multi-phase machines are supported.

Timer 12 Features

- Three capture/compare channels, each channel can be used either as capture or as compare channel.
- Generation of a three-phase PWM supported (six outputs, individual signals for highside and lowside switches)
- 16 bit resolution, maximum count frequency = system clock
- Dead-time control for each channel to avoid short-circuits in the power stage
- Concurrent update of the required T12/13 registers
- Center-aligned and edge-aligned PWM can be generated
- Single-shot mode supported
- Many interrupt request sources
- Hysteresis-like control mode

Timer 13 Features

- One independent compare channel with one output
- 16 bit resolution, maximum count frequency = system clock
- Can be synchronized to T12
- Interrupt generation at period-match and compare-match
- Single-shot mode supported

Additional Features

- Block commutation for Brushless DC-drives implemented
- Position detection via Hall-sensor pattern
- Automatic rotational speed measurement for block commutation
- Integrated error handling
- Fast emergency stop without CPU load via external signal ($\overline{\text{CTRAP}}$)
- Control modes for multi-channel AC-drives
- Output levels can be selected and adapted to the power stage
- Capture/compare unit can be powerdown in normal, idle and slow-down modes

The timer T12 can work in capture and/or compare mode for its three channels. The modes can also be combined. The timer T13 can work in compare mode only. The multi-channel control unit generates output patterns which can be modulated by T12 and/or T13. The modulation sources can be selected and combined for the signal modulation.

Switching Examples

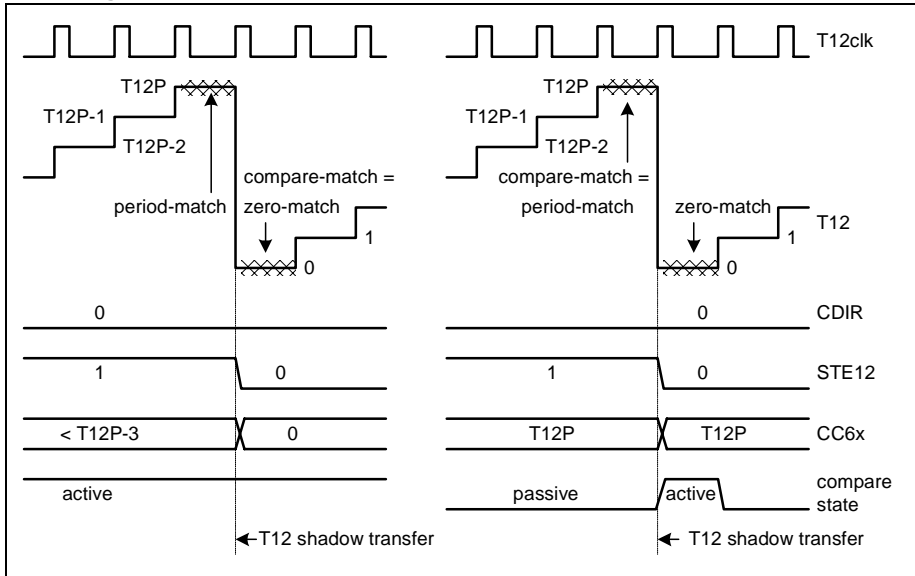

**Figure 16 Edge-aligned mode with duty cycles near 100% and near 0%.
Applicable to T13 as well.**

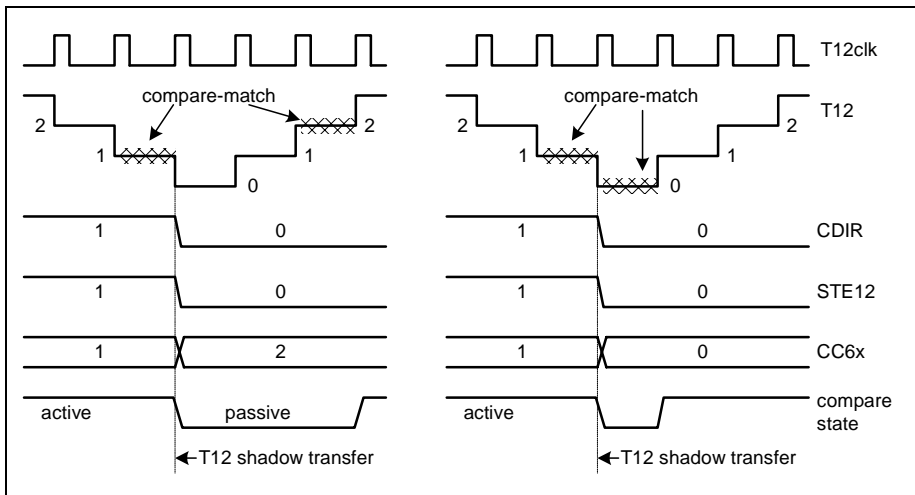

Figure 17 Centre-aligned mode with duty cycles near 100% and near 0%.

Dead-time Generation

The dead-time generation logic is built in a similar way for all three channels of T12. Each of the three channels works independently with its own dead-time counter and the trigger and enable signals.

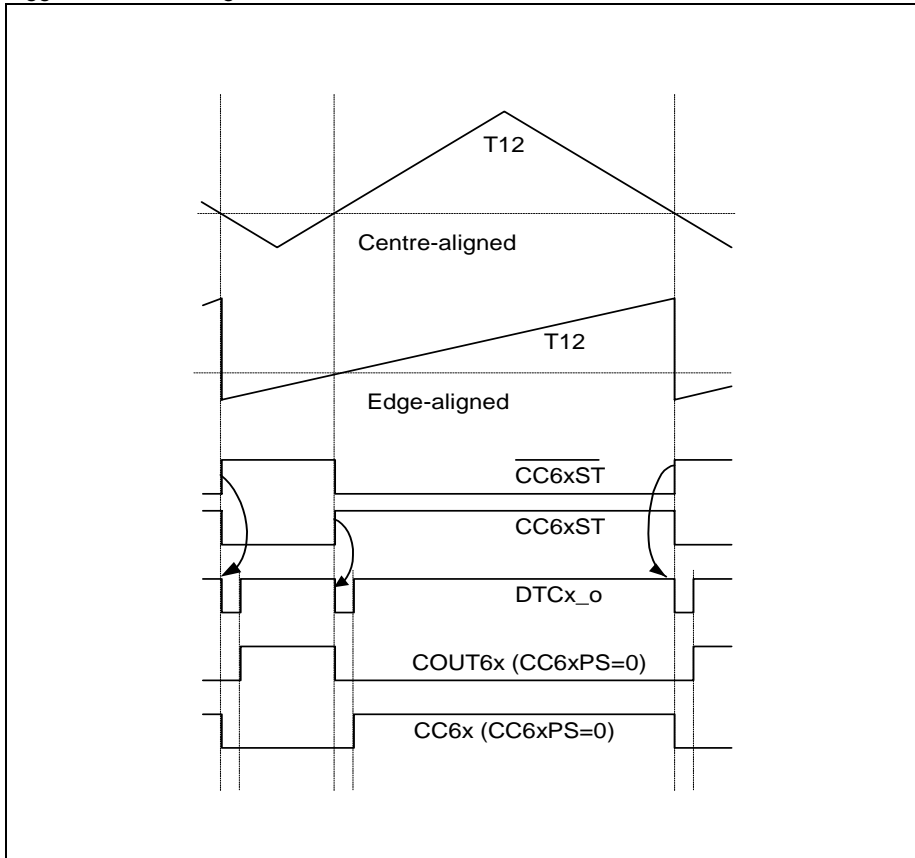

Figure 18 Dead-time generation for centre and edge aligned modes

Capture Mode

In capture mode the bits CC6xST indicate the occurrence of the selected capture event according to the bit fields MSEL6x. A rising and/or a falling edge on the pins CC6x can be selected as capture event, that is used to transfer the contents of timer T12 to the CC6xR and CC6xSR registers. In order to work in capture mode, the capture pins have to be configured as inputs.

Single Shot Mode

In single shot mode, the timer T12 stops automatically at the end of its counting period.

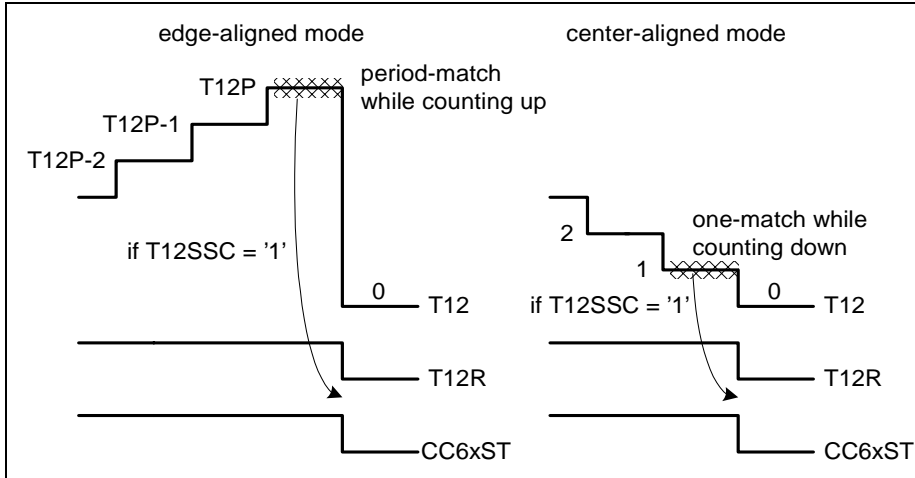

Figure 19 Single Shot Mode of T12, T13 is edge-aligned mode only.

Hysteresis-Like Control Mode

The hysteresis-like control mode (MSEL6x = '1001') offers the possibility to switch off the PWM output if the input CCPOSx becomes '0'. This can be used as a simple motor control feature by using a comparator indicating e.g. over current.

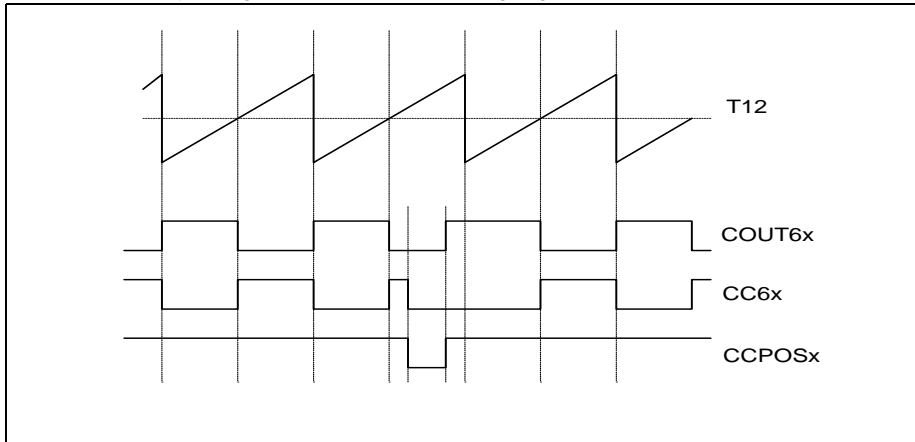
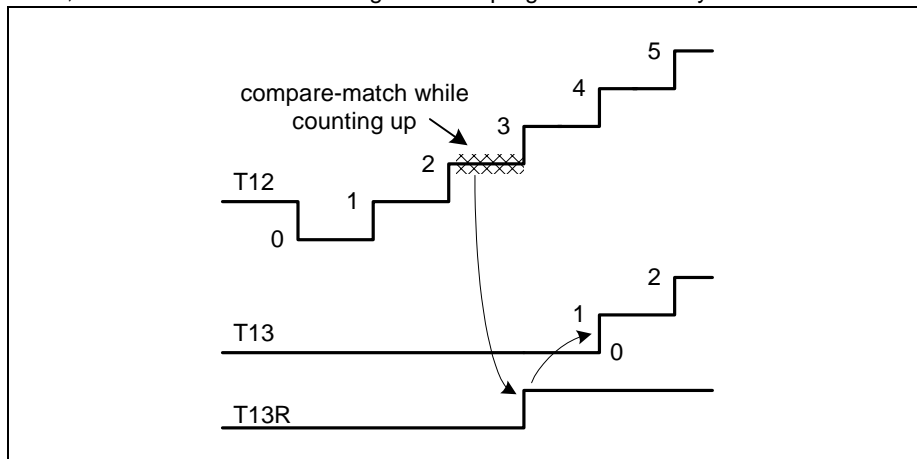

Figure 20 Hysteresis-like control mode

Synchronization of T13 to T12

The timer T13 can be synchronized on a T12 event. Combined with the single shot mode, this feature can be used to generate a programmable delay after a T12 event.



Synchronization of T13 to T12

Multi-channel Mode

The multi-channel mode offers a possibility to modulate all six T12-related output signals within one instruction. The bits in bit field MCMP are used to select the outputs that may become active. If the multi-channel mode is enabled (bit MCMEN='1'), only those outputs may become active, which have a '1' at the corresponding bit position in bit field MCMP.

This bit field has its own shadow bit field MCMPS, which can be written by SW. The transfer of the new value in MCMPS to the bit field MCMP can be triggered by and synchronized to T12 or T13 events. This structure permits the SW to write the new value, which is then taken into account by the HW at a well-defined moment and synchronized to a PWM period. This avoids unintended pulses due to unsynchronized modulation sources (T12, T13, SW).

Trap Handling

The trap functionality permits the PWM outputs to react on the state of the input pin CTRAP. This functionality can be used to switch off the power devices if the trap input becomes active (e.g. as emergency stop).

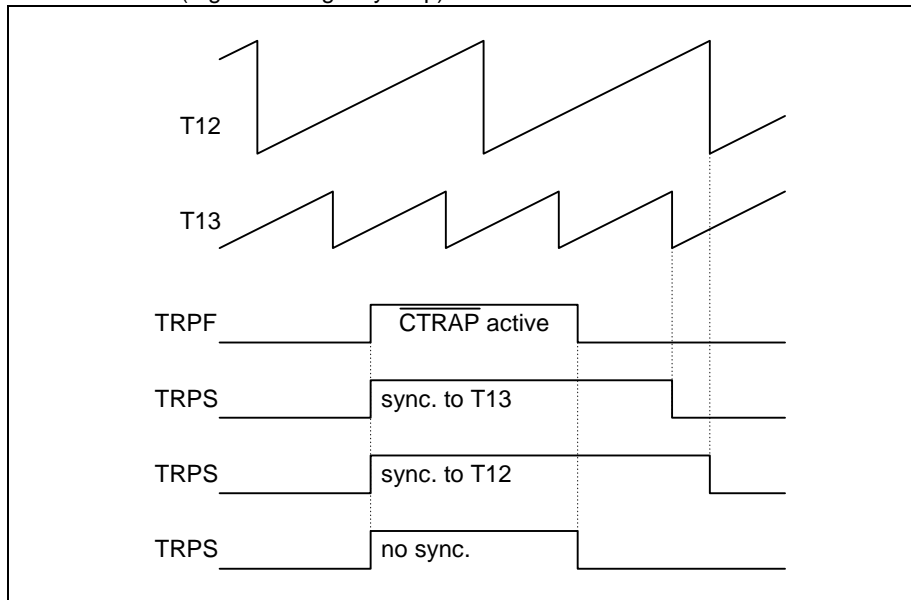

Figure 21 Trap State Synchronization (with TRM2='0')

Modulation control

The modulation control part combines the different modulation sources, six T12-related signals from the three compare channels, the T13-related signal and the multi-channel modulation signals. each modulation source can be individually enabled for each output line. Furthermore, the trap functionality is taken into account to disable the modulation of the corresponding output line during the trap state (if enabled).

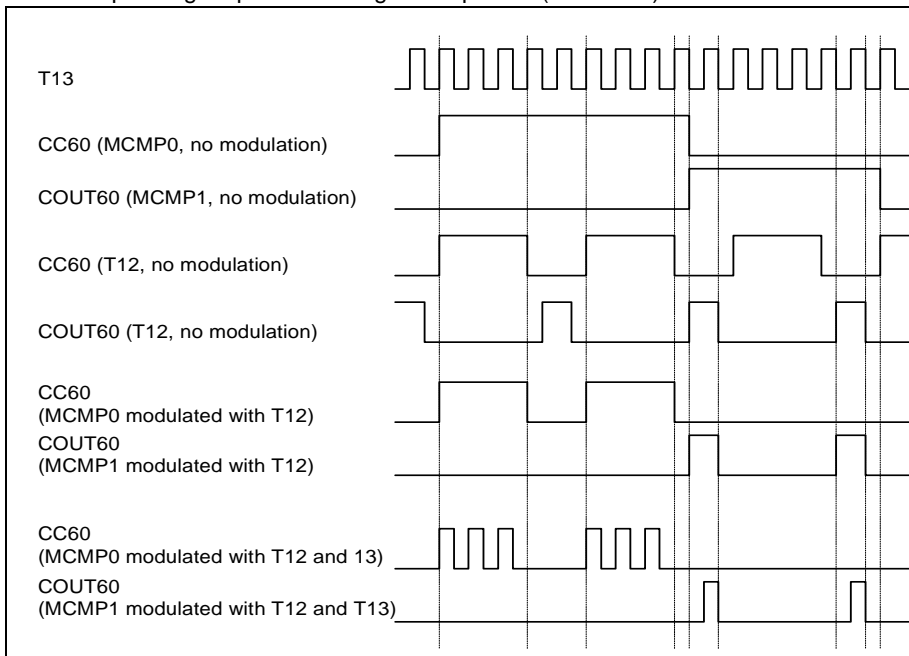

Figure 22 Modulation Control example for CC60 and COUT60.

Hall Sensor Mode

In **Brushless-DC motors** the next multi-channel state values depend on the pattern of the Hall inputs. There is a strong correlation between the **Hall pattern** (CURH) and the **modulation pattern** (MCMP). Because of different machine types the modulation pattern for driving the motor can be different. Therefore it is wishful to have a wide flexibility in defining the correlation between the Hall pattern and the corresponding modulation pattern. The CCU6 offers this by having a register which contains the actual Hall pattern (CURHS), the next expected Hall pattern (EXPHS) and its output pattern (MCMPS). At every correct Hall event (CHE, see figure *Hall Event Actions*) a new Hall pattern with its corresponding output pattern can be loaded (from a predefined table) by software into the register MCMOUTS. Loading this shadow register can also be done by a write action on MCMOUTS with bit STRHP = '1'

The **sampling** of the Hall pattern (on CCPOSx) is done with the T12 clock. By using the dead-time counter DTC0 (mode MSEL6x= '1000') a hardware **noise filter** can be implemented to suppress spikes on the Hall inputs due to high di/dt in rugged inverter environment. In case of a Hall event the DTC0 is reloaded and starts counting. When the counter value of one is reached, the CCPOSx inputs are sampled (without noise and spikes) and are compared to the current Hall pattern (CURH) and to the expected Hall pattern (EXPH). If the sampled pattern equals to the current pattern the edge on CCPOSx was due to a noise spike and no action will be triggered (implicit noise filter). If the sampled pattern equals to the next expected pattern the edge on CCPOSx was a correct Hall event, the bit CHE is set which causes an interrupt and the resets T12 (for speed measurement, see description mode '1000' below).

This correct Hall event can be used as a transfer request event for register MCMOUTS. The transfer from MCMOUTS to MCMOUT transfers the new CURH-pattern as well as the next EXPH-pattern. In case of the sampled Hall inputs were neither the current nor the expected Hall pattern, the bit WHE (wrong Hall event) is set which also can cause an interrupt and sets the IDLE mode clearing MCMP (modulation outputs are inactive). To restart from IDLE the transfer request of MCMOUTS have to be initiated by software (bit STRHP and bitfields SWSEL/SWSYN).

Below is a table listing output (MCMP) for a BLDC motor.

Block Commutation Control Table

| Mode | CCPOS0- CCPOS2 Inputs | | | CC60 - CC62 Outputs | | | COUT60 - COUT62 Outputs | | |
|--------------------------------|--------------------------|------------|------------|------------------------|----------|----------|----------------------------|------------|------------|
| | CCP OS0 | CCP OS1 | CCP OS2 | CC60 | CC61 | CC62 | COUT6 0 | COUT6 1 | COUT6 2 |
| Rotate left, 0° phase shift | 1 | 0 | 1 | inactive | inactive | active | inactive | active | inactive |
| | 1 | 0 | 0 | inactive | inactive | active | active | inactive | inactive |
| | 1 | 1 | 0 | inactive | active | inactive | active | inactive | inactive |
| | 0 | 1 | 0 | inactive | active | inactive | inactive | inactive | active |
| | 0 | 1 | 1 | active | inactive | inactive | inactive | inactive | active |
| | 0 | 0 | 1 | active | inactive | inactive | inactive | active | inactive |
| Rotate right | 1 | 1 | 0 | active | inactive | inactive | inactive | active | inactive |
| | 1 | 0 | 0 | active | inactive | inactive | inactive | inactive | active |
| | 1 | 0 | 1 | inactive | active | inactive | inactive | inactive | active |
| | 0 | 0 | 1 | inactive | active | inactive | active | inactive | inactive |
| | 0 | 1 | 1 | inactive | inactive | active | active | inactive | inactive |
| | 0 | 1 | 0 | inactive | inactive | active | inactive | active | inactive |
| Slow down | X | X | X | inactive | inactive | inactive | active | active | active |
| Idle ¹⁾ | X | X | X | inactive | inactive | inactive | inactive | inactive | inactive |

¹⁾ In case of the sampled Hall inputs were neither the current nor the expected Hall pattern, the bit WHE (wrong Hall event) is set which also can cause an interrupt and sets the IDLE mode clearing MCMP (modulation outputs are inactive).

For **Brushless-DC** motors there is a special mode (MSEL6x = '1000b') which is triggered by a change of the Hall-inputs (CCPOSx). This mode shows the capabilities of the CCU6. Here T12's channel 0 acts in capture function, channel 1 and 2 in compare function (without output modulation) and the multi-channel-block is used to trigger the output switching together with a possible modulation of T13.

After the detection of a valid Hall edge the T12 count value is captured to channel 0 (representing the actual motor speed) and resets the T12. When the timer reaches the compare value in channel 1, the next multi-channel state is switched by triggering the shadow transfer of bit field MCMP (if enabled in bit field SWEN). This trigger event can be combined with several conditions which are necessary to implement a noise filtering (correct Hall event) and to synchronize the next multi-channel state to the modulation sources (avoiding spikes on the output lines). This compare function of channel 1 can be used as a phase delay for the position input to the output switching which is necessary if a sensorless back-EMF technique is used instead of Hall sensors. The compare value in channel 2 can be used as a time-out trigger (interrupt) indicating that the motors destination speed is far below the desired value which can be caused by a abnormal load change. In this mode the modulation of T12 has to be disabled (T12MODENx = '0').

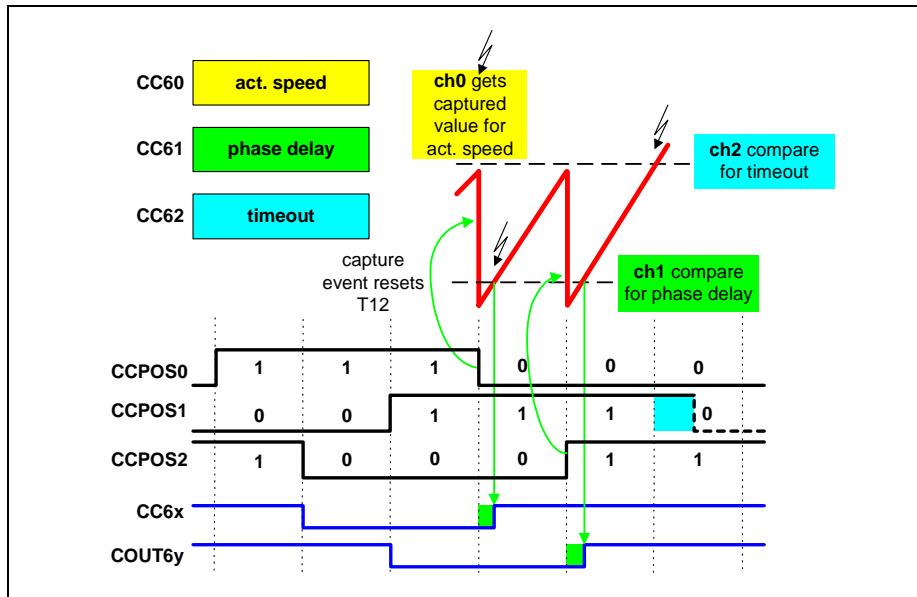

Figure 0-2 Timer T12 Brushless-DC Mode (MSEL6x = 1000)

A/D Converter

The C868 includes a high performance / high speed 8-bit A/D-Converter (ADC) with 5 analog input channels. It operates with a successive approximation technique and uses self calibration mechanisms for reduction and compensation of offset and linearity errors. The A/D converter provides the following features:

- 5 multiplexed input channels, which can also be used as digital inputs
- 8-bit resolution with TUE of +/- 2 LSB8.
- Single or continuous conversion mode
- Start of conversion by software and hardware
- Interrupt request generation after each conversion
- Using successive approximation conversion technique via a capacitor array
- Powerdown in normal, idle and slow-down modes

The ADC supports two conversion modes - single and continuous conversions. For each mode, there are two ways in which conversion can be started - by software and by the T13PM signal from the CCU module.

Writing a '0' to bit CCU_ADEX select conversion control by ADST. Writing a '1' to bit field ADST starts conversion on the channel that is specified by ADCH. In single conversion mode, bit field ADM is cleared to '0'. This is the default mode selected after hardware reset. When a conversion is started, the channel specified is sampled. The busy flag ADBSY is set and ADST is cleared. When the conversion is completed, the interrupt request signal ADCIRQ is asserted positively for 2 clocks and the 8-bit result together with the number of the converted channel is transferred to the result register ADDATH.

In continuous conversion mode, bit field ADM is set to '1'. In this mode, the ADC repeatedly converts the channel specified by ADCH. Bit ADST is cleared at the beginning of the first conversion. The busy flag ADBSY is asserted until the last conversion is completed. At the end of each conversion, the interrupt request signal ADCIRQ will be activated. To stop conversion, ADM has to be reset by software. If the channel number ADCH is changed while continuous conversion is in progress, the new channel specified will be sampled in the conversions that follow.

A new request to start conversion will be allowed only after the completion of any conversion that is in progress.

Writing a '1' to bit CCU_ADEX select conversion control by T13PM trigger signal from the CCU module.

Note: Caution must be taken when changing conversion start source. To change conversion source from software to hardware trigger, it is best to let remaining software conversion to complete before changing. To change conversion source from hardware trigger to software, it is best to change source first, let any

remaining hardware conversion to complete before beginning a software conversion.

Conversion and sample time control

The conversion and sample times are programmed via the bit fields ADCTC and ADSTC respectively of the register ADCON1. Bit field ADCTC (conversion time control) selects the internal ADC clock - adc_clk. Bit field ADSTC (sample time control) selects the sample time.

The total A/D conversion time is given by:

$$t_{ADCC} = 2/f_{SYS} + t_S + 8/adc_clk \quad [5]$$

The sample time t_S is configured in periods of the selected internal ADC clock. The table below lists the possible combinations.

| ADCTC | Clock Divider (TVC) | ADC Basic Clock adc_clk | ADSTC | Sample Time t_S (Periods of adc_clk, STC) |
|---------------|---------------------|-------------------------|---------------|---|
| 000 (default) | 32 | $f_{SYS} / 32$ | 000 (default) | 2 |
| 001 | 28 | $f_{SYS} / 28$ | 001 | 4 |
| 010 | 24 | $f_{SYS} / 24$ | 010 | 6 |
| 011 | 20 | $f_{SYS} / 20$ | 011 | 8 |
| 100 | 16 | $f_{SYS} / 16$ | 100 | 10 |
| 101 | 12 | $f_{SYS} / 12$ | 101 | 12 |
| 110 | 8 | $f_{SYS} / 8$ | 110 | 14 |
| 111 | 4 | $f_{SYS} / 4$ | 111 | 16 |

Interrupt System

The C868 provides 13 interrupt vectors with four priority levels. Nine interrupt requests are generated by the on-chip peripherals (timer 0, timer 1, timer 2, serial channel, A/D converter, and the capture/compare unit with 4 interrupts) and four interrupts may be triggered externally.

The wake-up from power-down mode interrupt has a special functionality which allows the software power-down mode to be terminated by a short negative pulse at pins CCPOS0/T2/INT0/AN0 or P1.4/RxD.

The 13 interrupt sources are divided into six groups. Each group can be programmed to one of the four interrupt priority levels. Additionally, 4 of these interrupt sources are channeled from 7 Capture/Compare (CCU6) interrupt sources.

Figure 23 to **Figure 28** give a general overview of the interrupt sources and illustrate the request and control flags.

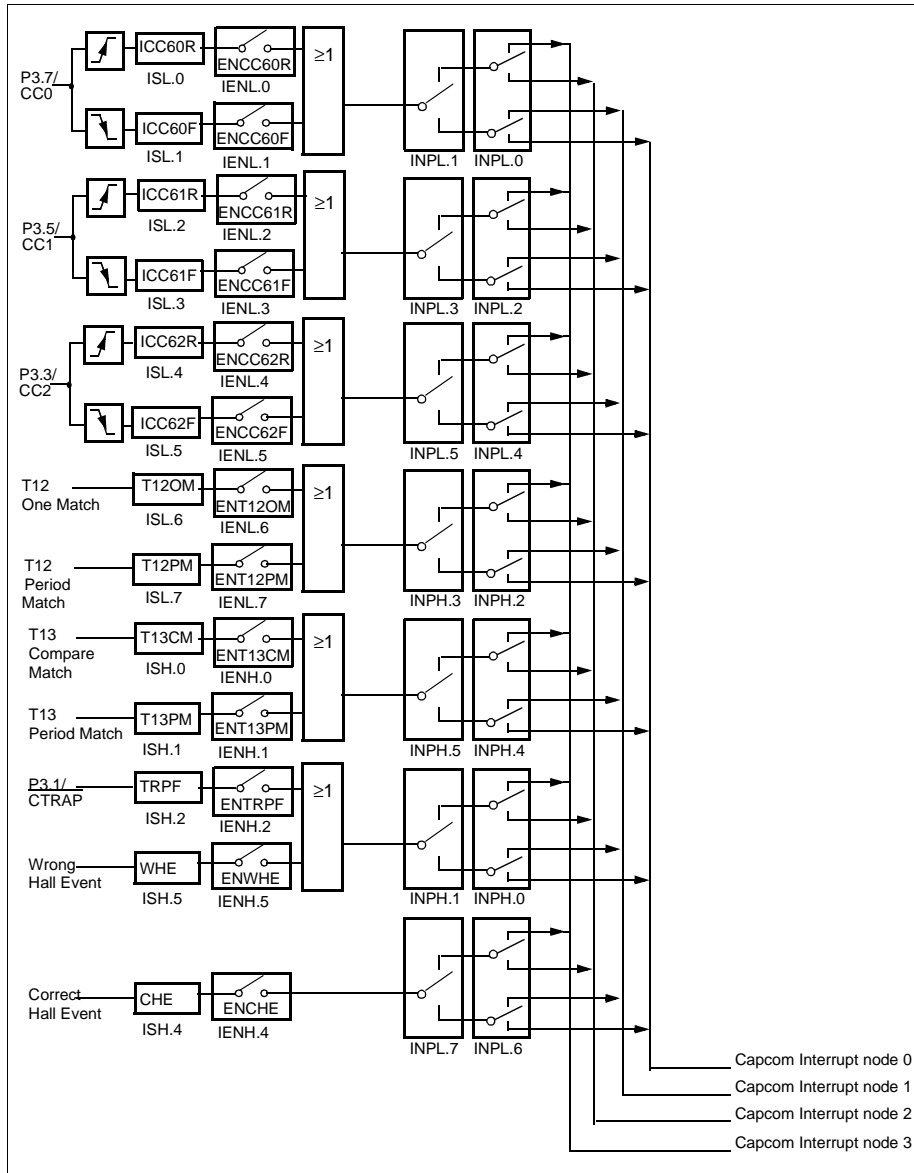

Figure 23 Capture/Compare module interrupt structure

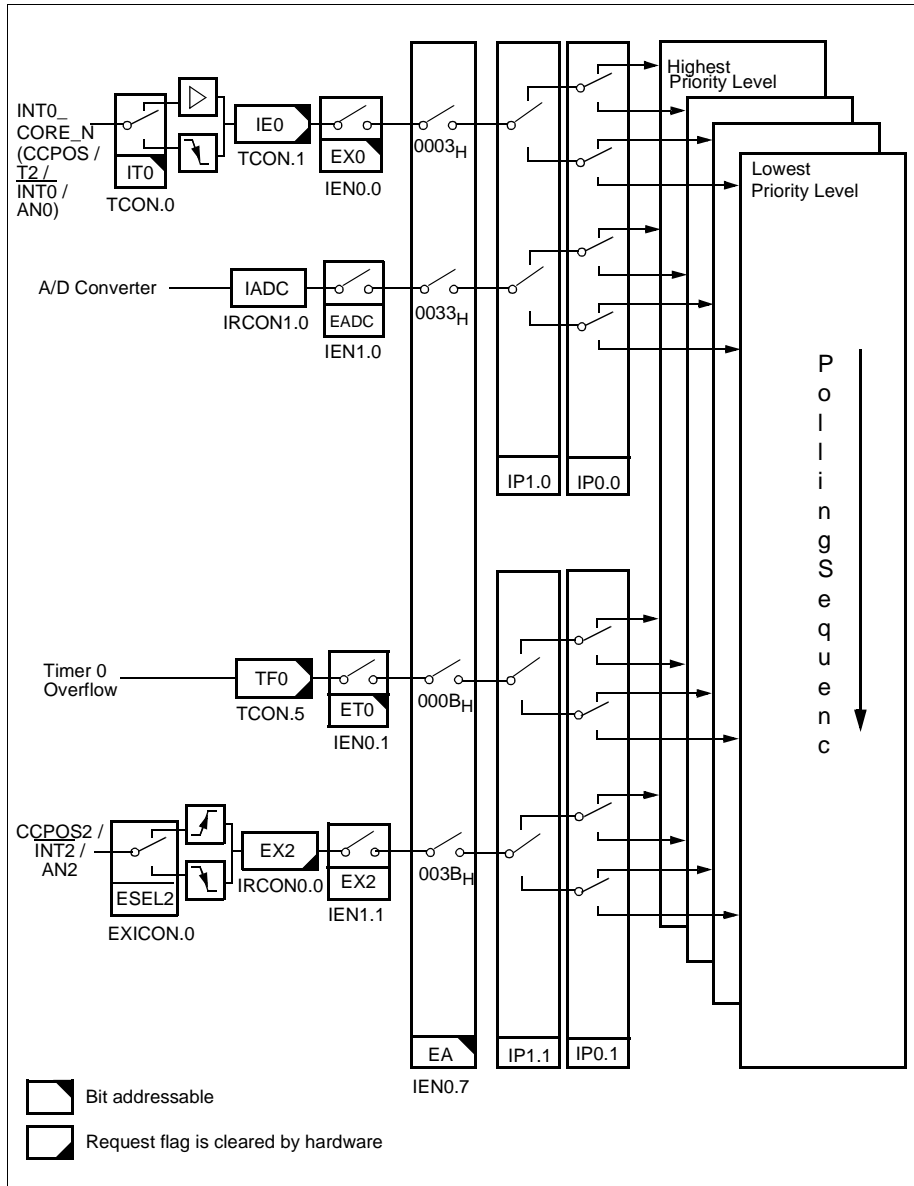

Figure 24 Interrupt Structure, Overview Part 1

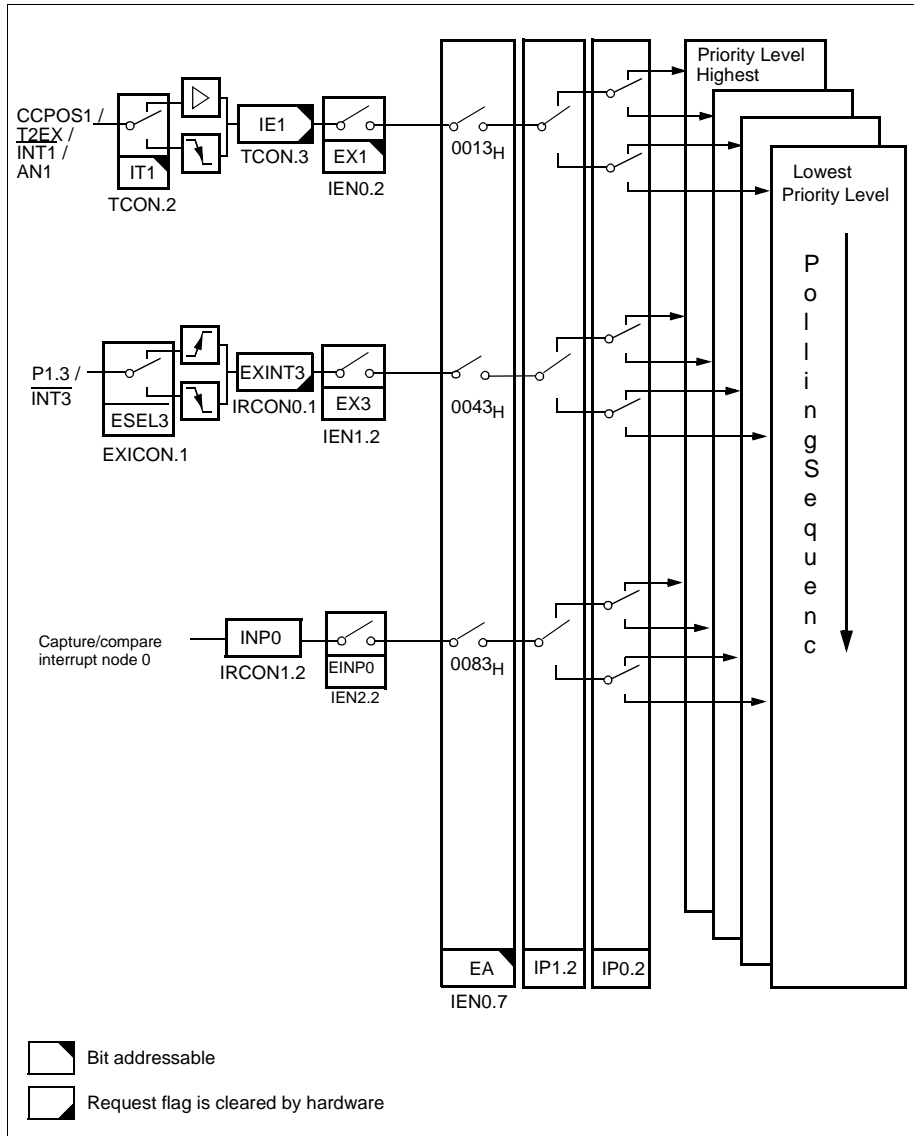

Figure 25 Interrupt Structure, Overview Part 2

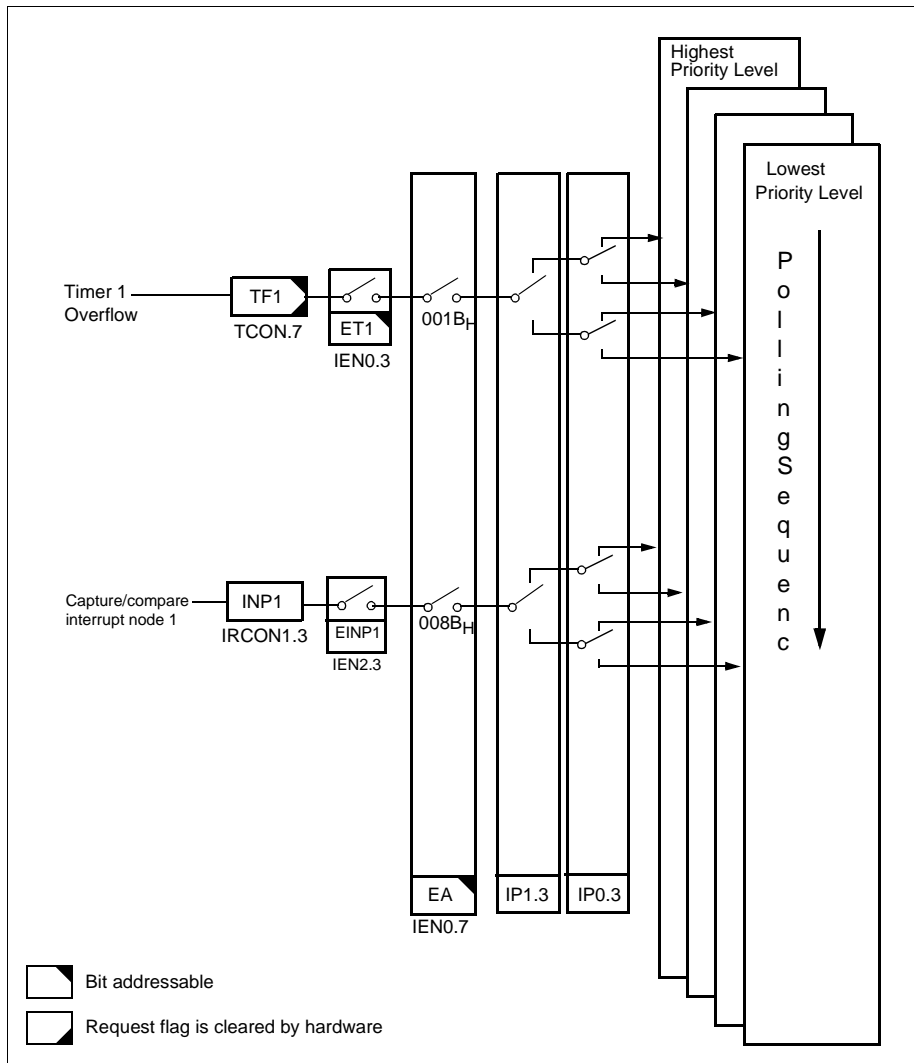

Figure 26 Interrupt Structure, Overview Part 3

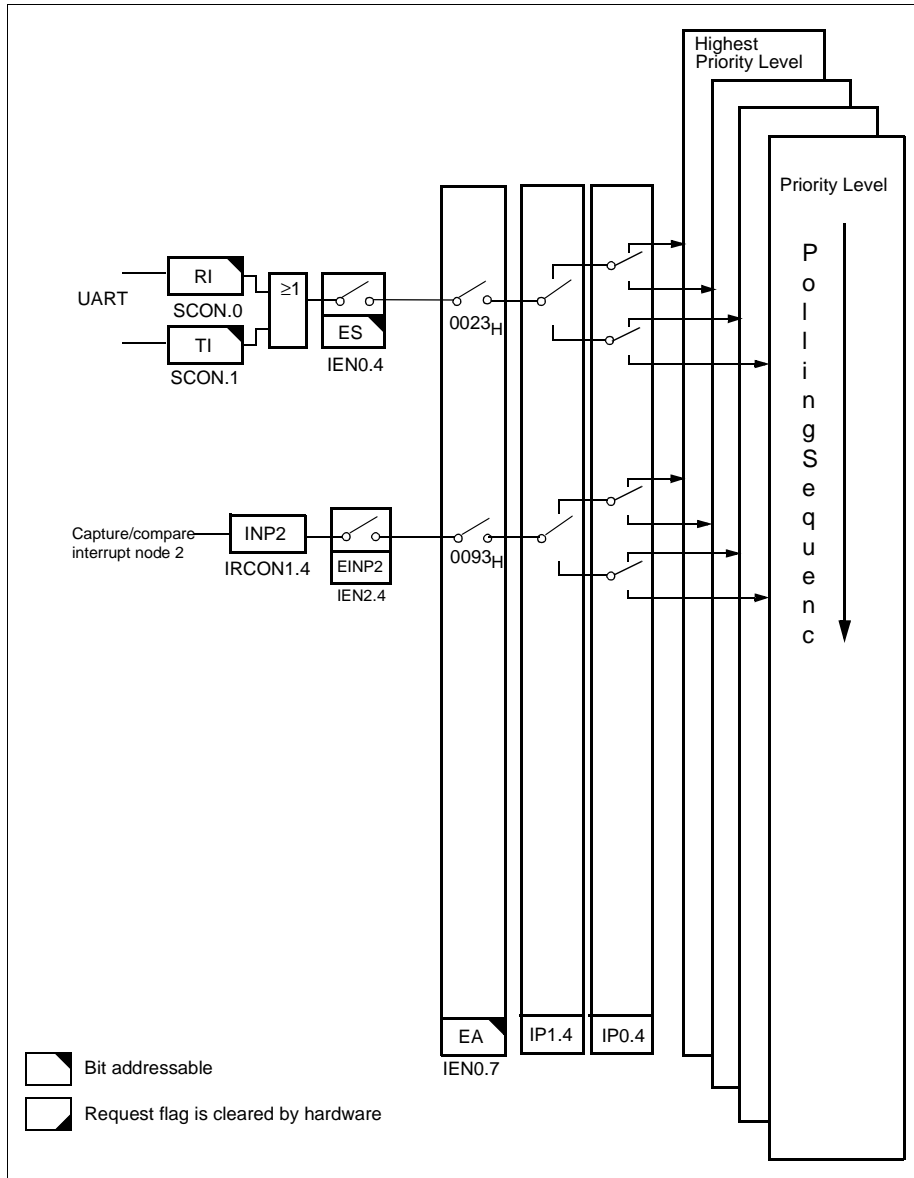

Figure 27 Interrupt Structure, Overview Part 4

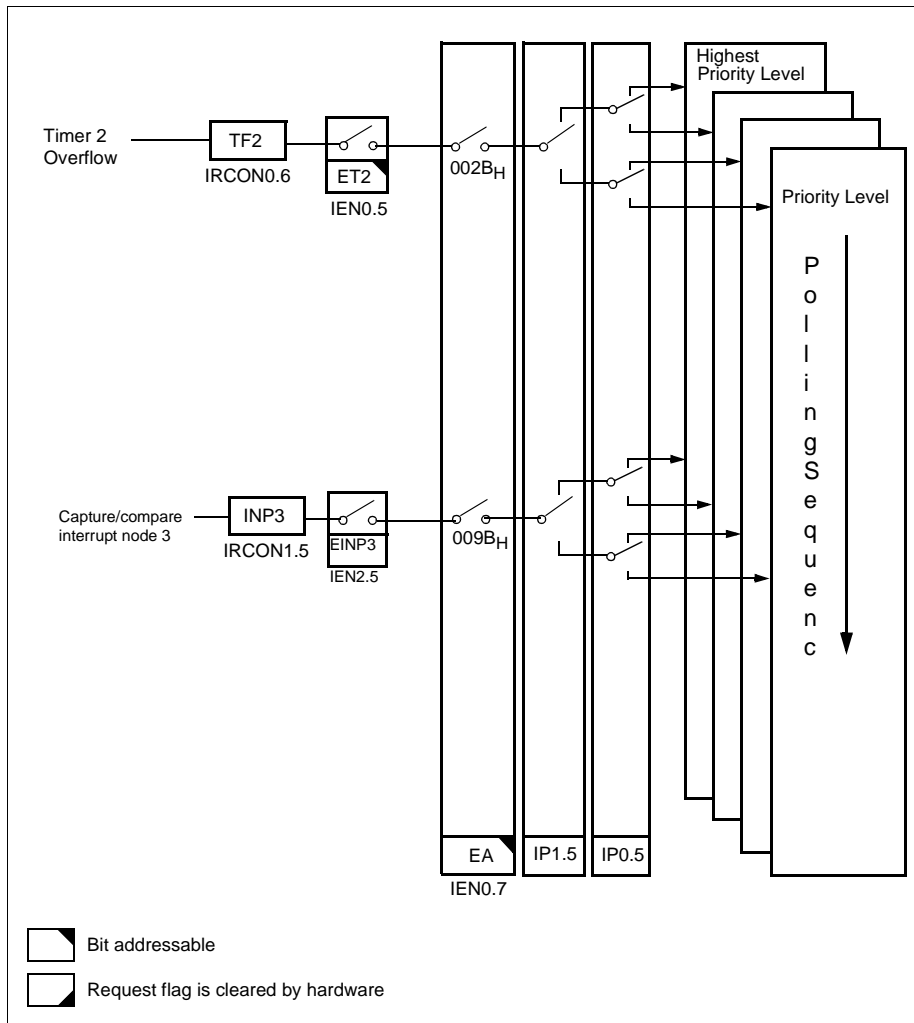

Figure 28 Interrupt Structure, Overview Part 5

Table 12 Interrupt Source and Vectors

| Interrupt Source | Interrupt Vector Address(core connections) | Interrupt Request Flags |
|------------------------------|--|-------------------------|
| External Interrupt 0 | 0003 _H (EX0) | IE0 |
| Timer 0 Overflow | 000B _H (ET0) | TF0 |
| External Interrupt 1 | 0013 _H (EX1) | IE1 |
| Timer 1 Overflow | 001B _H (ET1) | TF1 |
| Serial Channel | 0023 _H (ES) | RI / TI |
| Timer 2 Overflow | 002B _H (EX5) | TF2 |
| A/D Converter | 0033 _H (EX6) | IADC |
| External Interrupt 2 | 003B _H (EX7) | IEX2 |
| External Interrupt 3 | 0043 _H (EX8) | IEX3 |
| | 004B _H (EX9) | |
| | 0053 _H (EX10) | |
| | 005B _H (EX11) | |
| | 0063 _H (EX12) | |
| | 006B _H (EX13) | |
| CAPCOM interrupt node 0 | 0083 _H (EX14) | INP0 ¹⁾ |
| CAPCOM interrupt node 1 | 008B _H (EX15) | INP1 ¹⁾ |
| CAPCOM interrupt node 2 | 0093 _H (EX16) | INP2 ¹⁾ |
| CAPCOM interrupt node3 | 009B _H (EX17) | INP3 ¹⁾ |
| | 00A3 _H (EX18) | |
| | 00AB _H (EX19) | |
| | 00D3 _H (EX20) | |
| | 00DB _H (EX21) | |
| | 00E3 _H (EX22) | |
| Wake-up from power-down mode | 007B _H | – |

¹⁾ Capture/compare has 10 interrupt sources channeled to the 4 interrupt nodes INP0..3. The 3 capture/compare ports has 3 pairs of interrupt request flags, ICC60R, ICC60F, ICC61R, ICC61F, ICC62R, ICC62F. The other flags are T12OM, T12PM, T13CM, T13PM, TRPF, WHE, CHE.

If two or more requests of different priority levels are received simultaneously, the request of the highest priority is serviced first. If requests of the same priority level are received simultaneously, an internal polling sequence determines which request is to be serviced first. Thus, within each priority level there is a second priority structure determined by the polling sequence. This is illustrated in [Table 13](#)

Table 13 Interrupt Source Structure

| Interrupt Group | Priority Bits of Interrupt Group | Interrupt Source Priority | | | | Priority |
|-----------------|----------------------------------|---------------------------|--------|--------------------|-----|----------|
| | | High Priority | → | | Low | |
| 0 | IP0.0 | EXINT0 | IADC | | | High |
| 1 | IP0.1 | TF0 | EXINT2 | | | ↓ |
| 2 | IP0.2 | EXINT1 | EXINT3 | INP0 ¹⁾ | | |
| 3 | IP0.3 | TF1 | | INP1 ¹⁾ | | |
| 4 | IP0.4 | RI + TI | | INP2 ¹⁾ | | |
| 5 | IP0.5 | TF2 | | INP3 ¹⁾ | | |

¹⁾ Capture/compare has 10 interrupt sources channeled to the 4 interrupt nodes INP0..3. The 3 capture/compare ports has 3 pairs of interrupt request flags, ICC60R, ICC60F, ICC61R, ICC61F, ICC62R, ICC62F. The other flags are T12OM, T12PM, T13CM, T13PM, TRPF, WHE, CHE.

Within a column, the topmost interrupt is serviced first, then the second and the third, when available. The interrupt groups are serviced from left to right of the table. A low-priority interrupt can itself be interrupted by a higher-priority interrupt, but not by another interrupt of the same or a lower priority. An interrupt of the highest priority level cannot be interrupted by another interrupt source.

Fail Save Mechanisms

The C868 offers enhanced fail save mechanisms, which allow an automatic recovery from software upset or hardware failure :

a programmable watchdog timer (WDT), with variable time-out period from 12.8 μ s to 819.2 μ s at $f_{SYS} = 40$ MHz.

Programmable Watchdog Timer

To protect the system against software failure, the user's program has to clear this watchdog within a previously programmed time period. If the software fails to do this periodical refresh of the watchdog timer, an internal reset will be initiated. The software can be designed so that the watchdog times out if the program does not work properly. It also times out if a software error is based on hardware-related problems.

The watchdog timer in the C868 is a 16-bit timer, which is incremented by a count rate of $f_{SYS}/2$ upto $f_{SYS}/128$. The machine clock of the C868 is divided by a prescaler, a divide-by-two or a divide-by-128 prescaler. The upper 8 bits of the Watchdog Timer can be preset to a user-programmable value via a watchdog service access in order to vary the watchdog expire time. The lower 8 bits are reset on each service access. [Figure 29](#) shows the block diagram of the watchdog timer unit.

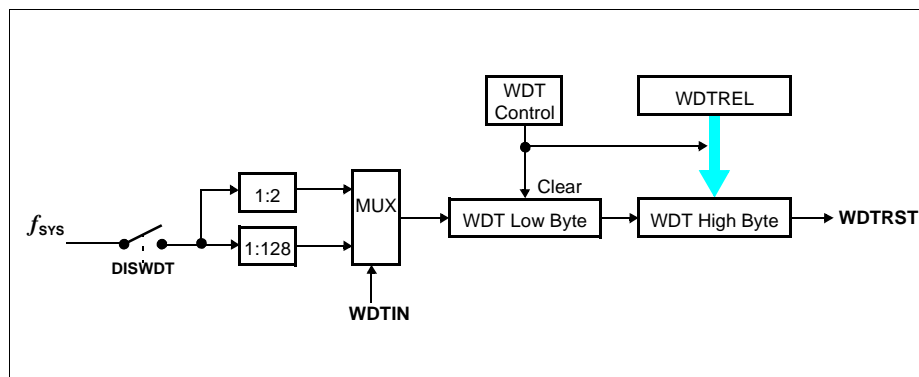

Figure 29 Block Diagram of the Programmable Watchdog Timer

After a reset, the Watchdog Timer is automatically enabled. If it is disabled, it cannot be enabled again during active mode of the device. If the software fails to clear the watchdog timer an internal reset will be initiated. The reset cause (external reset or reset caused by the watchdog) can be examined by software (status flag $WDTR$ in $SCUWDT$ is set). A refresh of the watchdog timer is done by setting bits $WDTRE$ and $WDRS$ (in

SFR SCUWDT) consecutively. This double instruction sequence has been implemented to increase system security.

It must be noted, however, that the watchdog timer is halted during the idle mode and power-down mode of the processor (see section "Power Saving Modes"). It is not possible to use the idle mode in combination with the watchdog timer function. Therefore, even the watchdog timer cannot reset the device when one of the power saving modes has been entered accidentally.

The time period for an overflow of the Watchdog Timer is programmable in two ways :

- **the input frequency** to the Watchdog Timer can be selected via bit WDTIN in register WDTCON to be either $f_{SYS}/2$ or $f_{SYS}/128$.
- **the reload value** WDTREL for the high byte of WDT can be programmed in register WDTCON.

The period P_{WDT} between servicing the Watchdog Timer and the next overflow can therefore be determined by the following formula:

$$P_{WDT} = \frac{2^{(1+WDTIN*6)} * (2^{16} - WDTREL * 2^8)}{f_{SYS}} \quad [0.1]$$

Table 14 lists the possible ranges for the watchdog time which can be achieved using a certain module clock. Some numbers are rounded to 3 significant digits.

Table 14 Watchdog Time Ranges

| Reload value in WDTREL | Prescaler for f_{SYS} | | | | | |
|---------------------------|-------------------------|---------|---------|-------------------|----------|---------|
| | 2 (WDTIN = '0') | | | 128 (WDTIN = '1') | | |
| | 40 MHz | 20 MHz | 16 MHz | 40 MHz | 20 MHz | 16 MHz |
| FF _H | 12.8 μs | 25.6 μs | 32.0 μs | 819.2 μs | 1.64 ms | 2.05 ms |
| 7F _H | 1.65 ms | 3.3 ms | 4.13 ms | 105.7 ms | 211.3 ms | 264 ms |
| 00 _H | 3.28 ms | 6.55 ms | 8.19 ms | 209.7 ms | 419.4 ms | 524 ms |

For safety reasons, the user is advised to rewrite WDTCON each time before the Watchdog Timer is serviced.

Power Saving Modes

The C868 provides two basic power saving modes, the idle mode and the power down mode. Additionally, a slow down mode is available. This power saving mode reduces the internal clock rate in normal operating mode and it can also be used for further power reduction in idle mode.

- **Idle Mode**

In the idle mode, the oscillator of the C868 continues to run, but the CPU is gated off from the clock signal. However, the interrupt system, the serial port, the A/D converter, the capture/compare unit, and all timers are further provided with the clock. The CPU status is preserved in its entirety: the stack pointer, program counter, program status word, accumulator, and all other registers maintain their data during idle mode.

- **Slow Down Mode**

In some applications, where power consumption and dissipation are critical, the controller might run for a certain time at reduced speed (for example, if the controller is waiting for an input signal). Since in CMOS devices, there is an almost linear dependence of the operating frequency and the power supply current, so, a reduction of the operating frequency results in reduced power consumption.

- **Software Power Down Mode**

In the software power down mode, the on-chip oscillator which operates with the XTAL pins and the PLL are all stopped. Therefore, all functions of the microcontroller are stopped and only the contents of the on-chip RAM, XRAM and the SFR's are maintained. The port pins, which are controlled by their port latches, output the values that are held by their SFR's. The port pins which serve the alternate output functions show the values they had at the end of the last cycle of the instruction which initiated the power down mode. ALE is held at logic low level or high impedance if disabled. In the power down mode of operation, V_{DDP} can be reduced to minimize power consumption. It must be ensured, however, that V_{DDP} is not reduced before the power down mode is invoked, and that V_{DDP} is restored to its normal operating level before the power down mode is terminated.

Table 15 Power Saving Modes Overview

| Mode | Entering | Leaving by | Remarks |
|--------------------------|--|---|--|
| Idle Mode | ORL PCON,#01 _H | Occurance of any enabled interrupt | CPU clock is stopped; CPU maintains its data; peripheral units are active (if enabled) and provided with clock |
| | | Hardware Reset | |
| Slow Down Mode | In normal mode: ORL PCON,#10 _H | ANL PCON,#0EF _H or Hardware Reset | Internal clock rate is reduced to a configurable factor of $1/2$ to $1/32$ of the system clock rate |
| | With idle mode: ORL PCON,#11 _H | Occurance of any enabled interrupt to exit idle mode and the instruction ANL PCON,#0EF _H to terminate slow down mode Hardware Reset | CPU clock is stopped; CPU maintains all its data; Peripheral units are active (if enabled) and provided with a configurable factor of $1/2$ to $1/32$ of the system clock rate |
| Software Power Down mode | With external wake-up capability from power down enabled ORL PMCON0,#01 _H (to wake-up via pin INT0) or ORL PMCON0,#03 _H (to wake-up via pin RxD) ORL PCON,#02 _H | Hardware Reset When $\overline{INT0}$ or RxD goes low for at least 10 μ s (latch phase). But it is desired that the corresponding pin must be held at high level during the power down mode entry and up to the wake-up. | Oscillator is stopped; Contents of on-chip RAM and SFR's are maintained |
| | With external wake-up capability from power down disabled ORL PCON,#02 _H | Hardware Reset | |

Device Specifications

Absolute Maximum Ratings

Absolute Maximum Rating Parameters

| Parameter | Symbol | Limit Values | | Unit | Notes |
|---|------------------|--------------|------|------|----------------|
| | | min. | max. | | |
| Ambient temperature under bias | T_A | -40 | 125 | °C | |
| Storage temperature | T_{STG} | -65 | 150 | °C | - |
| Voltage on V_{DDP} pins with respect to ground (V_{SSP}) | V_{DDP} | -0.3 | 4.6 | V | - |
| Voltage on any pin except int/ analog and XTAL with respect to ground (V_{SSP}) | V_{IN0} | -0.5 | 4.6 | V | - |
| Voltage on any int/analog pin with respect to ground (V_{SSP}) | V_{IN1} | -0.5 | 4.6 | V | - |
| Voltage on XTAL pins with respect to ground (V_{SSC}) | V_{IN2} | -0.5 | 4.6 | V | - |
| Input current on any pin during overload condition | I_{OV} | -10 | 10 | mA | ⁻¹⁾ |
| Absolute sum of all input currents during overload condition | $\Sigma I_{OV} $ | - | 43 | mA | - |
| Power dissipation | P_{DISS} | - | tbd | W | - |

¹⁾ Proper operation is not guaranteed if overload conditions occur on functional pins like XTAL2 etc.

Note: Stresses above those listed under "Absolute Maximum Ratings" may cause permanent damage to the device. This is a stress rating only and functional operation of the device at these or any other conditions above those indicated in the operational sections of this specification is not implied. Exposure to absolute maximum rating conditions for extended periods may affect device reliability. During absolute maximum rating overload conditions ($V_{IN} > V_{DDP}$ or $V_{IN} < V_{SSP}$, $V_{IN2} > V_{DDC}$ or $V_{IN2} < V_{SSC}$) the voltage on V_{DDP} pin with respect to ground (V_{SSP}) must not exceed the values defined by the absolute maximum ratings.

Operating Conditions

The following operating conditions must not be exceeded in order to ensure correct operation of the C868. All parameters specified in the following sections refer to these operating conditions, unless otherwise noticed.

Operating Condition Parameters

| Parameter | Symbol | Limit Values | | Unit | Notes |
|--|--------------------|-----------------|-----------------|------|---------------------------------------|
| | | min. | max. | | |
| Digital supply voltage | V_{DDP} | 3.0 | 3.6 | V | Active mode, $f_{SYSmax} = 40$ MHz |
| | | tbd | 3.6 | V | PowerDown mode ¹⁾ |
| Digital ground voltages | V_{SSC}, V_{SSP} | 0 | | V | - |
| Ambient temperature | T_A | -40 | 85 | °C | SAF-C868... |
| | | -40 | 125 | °C | SAK-C868... |
| Analog reference voltage | V_{AREF} | 3.0V | $V_{DDP} + 0.1$ | V | - |
| Analog ground voltage | V_{AGND} | $V_{SSP} - 0.1$ | $V_{SSP} + 0.1$ | V | - |
| Analog input voltage | V_{AIN} | V_{AGND} | V_{AREF} | V | - |
| External Clock | f_{OSC} | 6.67 | 10.67 | MHz | - |
| Input current on any pin during overload condition except int/ analog and XTAL | I_{OV0} | -5 | 5 | mA | - ²⁾³⁾ |
| int/analog pin | I_{OV1} | -2 | 5 | mA | - ³⁾⁴⁾ |
| XTAL pin | I_{OV2} | -5 | 5 | mA | - ³⁾⁵⁾ |
| Absolute sum of all input currents during overload condition | ΣI_{OV} | - | 20 | mA | - ³⁾ |

Notes:

- 1) Oscillator or external clock disabled.
- 2) Overload conditions under operating conditions occur if the voltage on the respective pin exceeds the specified operating range (i.e. $V_{OV} > V_{DDP} + 0.5V$ or $V_{OV} < V_{SSP} - 0.5V$). The absolute sum of input currents on all port pins may not exceed 20mA. The supply voltages V_{DDP} and V_{SSP} must remain within the specified limits.
- 3) Not 100% tested, but guaranteed by design characterization.

- 4) Overload conditions under operating conditions occur if the voltage on the respective pin exceeds the specified operating range (i.e. $V_{OV} > V_{DD}$ or $V_{OV} < V_{SSC} - 0.5V$). The absolute sum of input currents on all port pins may not exceed 20mA. The supply voltages V_{DDP} and V_{SSP} must remain within the specified limits.
- 5) Overload conditions under operating conditions occur if the voltage on the respective pin exceeds the specified operating range (i.e. $V_{OV} > V_{DDC} + 0.5V$ or $V_{OV} < V_{SSC} - 0.5V$). The absolute sum of input currents on all port pins may not exceed 20mA. The supply voltages V_{DDP} and V_{SSP} must remain within the specified limits.

DC Characteristics

(Operating Conditions apply)

| Parameter | Symbol | Limit Values | | Unit | Test Condition |
|---|-----------|----------------------|---------------|---------------|---|
| | | min. | max. | | |
| Input low voltages all except XTAL2, int/analog | V_{IL0} | -0.5 | $0.3V_{DDP}$ | V | - ¹⁾ |
| int/analog | V_{IL1} | -0.5 | $0.3V_{DDC}$ | V | |
| XTAL2 | V_{IL2} | -0.5 | $0.1V_{DDC}$ | V | |
| Input high voltages all except XTAL2, int/analog | V_{IH0} | $0.7V_{DDP}$ | $V_{DDP}+0.5$ | V | - |
| int/analog | V_{IH1} | $0.7V_{DDC}$ | $V_{DDP}+0.5$ | V | |
| XTAL2 | V_{IH2} | $0.7V_{DDC}$ | $V_{DDC}+0.5$ | V | |
| Output low voltage | V_{OL} | - | 0.45 | V | SAF-C868... $I_{OL}=10\text{mA}$ |
| | | - | 0.55 | V | SAK-C868... $I_{OL}=10\text{mA}$ |
| Output high voltage | V_{OH} | 2.4 | - | V | $I_{OH}=10\text{mA}$ |
| Input leakage current (all except int/analog) | I_{LI0} | - | ± 0.5 | μA | $0.4 < V_{IN} < V_{DDP}$ |
| Input leakage current (int/ analog) | I_{LI1} | - | ± 0.5 | μA | $0.4 < V_{IN} < V_{DDP}$ ²⁾ |
| Input low current (XTAL2) | I_{LI2} | - | ± 10 | μA | $0.4 < V_{IN} < V_{DDC}$ |
| Digital supply voltage | V_{DDC} | 2.25 ³⁾ | 2.75 | V | - |
| Blocking capacitor for V_{DDC} | | 136 | 470 | nF | - ⁴⁾ |
| Pin capacitance | C_{IO} | - | 10 | pF | $f_C = 1\text{MHz}$ $T_A = 25^\circ\text{C}$ |

Note:

- Interrupt/analog pins are input only and has CMOS characteristics whereas the other I/O pins have TTL characteristics.
- The leakage current of interrupt/analog pins depends on the leakage current of the CMOS pad for the digital functions and the analog pad.
- The V_{DDC} is measured under the following conditions:
Microcontroller in power down mode; $\overline{\text{RESET}} = V_{DDP}$; $\text{XTAL2} = V_{SSC}$; $\text{XTAL1} = \text{N.C.}$; $V_{AGND} = V_{SSP}$; $V_{AREF} = V_{DDP}$; $\text{Rx}/\text{INT0} = V_{DDP}$; all other pins are set to input and connected to gnd; ALE output disabled and connected to gnd; 20mA current sourced from the V_{DDC} pin.
- Ceramic type ($\pm 20\%$) max ESR: $25\text{m}\Omega$, max trace length to capacitor is 10mm.

Power Supply Current

| Parameter | | | Symbol | Limit Values | | Unit | Test Condition |
|------------------------------------|---------|----------------------|-----------|--------------------|--------------------|------|---------------------------|
| | | | | typ. ¹⁾ | max. ²⁾ | | |
| Active mode | C868-1S | 40 MHz ³⁾ | I_{DDP} | 13.1 | 15.6 | mA | 4) |
| | C868-1R | 40 MHz ³⁾ | I_{DDP} | 13.5 | 15.5 | mA | |
| Idle mode | C868-1S | 40 MHz ³⁾ | I_{DDP} | 7.8 | 9.6 | mA | 5) |
| | C868-1R | 40 MHz ³⁾ | I_{DDP} | 7.9 | 9.1 | mA | |
| Active mode with slow-down enabled | C868-1S | 40 MHz ³⁾ | I_{DDP} | 3.5 | 4.4 | mA | 6) |
| | C868-1R | 40 MHz ³⁾ | I_{DDP} | 3.6 | 4.1 | mA | |
| Idle mode with slow-down enabled | C868-1S | 40 MHz ³⁾ | I_{DDP} | 3.4 | 4.2 | mA | 7) |
| | C868-1R | 40 MHz ³⁾ | I_{DDP} | 3.6 | 4.1 | mA | |
| Power-down mode | C868-1S | | I_{PDP} | 240 | 300 | uA | SAF-C868... ⁸⁾ |
| | | | | 240 | 400 | uA | SAK-C868... ⁸⁾ |
| | C868-1R | | I_{PDP} | 240 | 300 | uA | SAF-C868... ⁸⁾ |
| | | | | 240 | 400 | uA | SAK-C868... ⁸⁾ |

Note:

- 1) The typical I_{DDP} values are periodically measured at $T_A = +25\text{ °C}$ but not 100% tested.
- 2) The maximum I_{DDP} values are measured under worst case conditions ($T_A = -40\text{ °C}$ and $V_{DDP} = 3.6\text{ V}$).
- 3) System clock, set by using external clock of 10.67MHz and setting KDIV in CMCON to 010 (factor of 4)
- 4) I_{DDP} (active mode) is measured with:
 $\overline{\text{XTAL2}}$ driven with $t_R, t_F = 5\text{ ns}$, $V_{IL1}, V_{IL2} = V_{SSP} + 0.5\text{ V}$, $V_{IH1}, V_{IH2} = V_{DDP} - 0.5\text{ V}$; $\text{XTAL1} = \text{N.C.}$;
 $\overline{\text{RESET}} = V_{DDP}$; all other pins are disconnected. $?I_{DDP}$ would be slightly higher if the crystal oscillator is used (approx. 1 mA).

- 5) I_{DDP} (idle mode) is measured with all output pins disconnected and with all peripheral disabled:
 $\overline{XTAL2}$ driven with $t_R, t_F = 5 \text{ ns}$, $V_{IL1}, V_{IL2} = V_{SSP} + 0.5 \text{ V}$, $V_{IH1}, V_{IH2} = V_{DDP} - 0.5 \text{ V}$; $XTAL1 = \text{N.C.}$;
 $\overline{RESET} = V_{DDP}$; all other pins are disconnected.
- 6) I_{DDP} (active mode with slow down mode) is measured with all output pins disconnected:
 $\overline{XTAL2}$ driven with $t_R, t_F = 5 \text{ ns}$, $V_{IL1}, V_{IL2} = V_{SSP} + 0.5 \text{ V}$, $V_{IH1}, V_{IH2} = V_{DDP} - 0.5 \text{ V}$; $XTAL1 = \text{N.C.}$;
 $\overline{RESET} = V_{DDP}$; all other pins are disconnected; the microcontroller is put into slow-down mode by software with the slow-down clock set to 1/32 of system clock.
- 7) I_{DDP} (idle mode with slow down mode) is measured with all output pins disconnected and with all peripheral disabled:
 $\overline{XTAL2}$ driven with $t_R, t_F = 5 \text{ ns}$, $V_{IL1}, V_{IL2} = V_{SSP} + 0.5 \text{ V}$, $V_{IH1}, V_{IH2} = V_{DDP} - 0.5 \text{ V}$; $XTAL1 = \text{N.C.}$;
 $\overline{RESET} = V_{DDP}$; all other pins are disconnected; the microcontroller is put into slow-down mode by software with the slow-down clock set to 1/32 of system clock.
- 8) I_{PDC} and I_{DDP} (power-down mode) are measured under the following conditions:
 $\overline{RESET} = V_{DDP}$; $XTAL2 = V_{SSC}$; $XTAL1 = \text{N.C.}$; $V_{AGND} = V_{SSP}$; $V_{AREF} = V_{DDP}$; $RxD/INT0 = V_{DDP}$; all other pins are set to input and connected to gnd; ALE output disabled and connected to gnd.

Power Supply Current Calculation Formulae

| Parameter | | Symbol | Formula ¹⁾ |
|------------------------------------|---------|-----------------|------------------------|
| Active mode | C868-1S | $I_{DDP_{typ}}$ | $0.25 * f_{SYS} + 3.1$ |
| | | $I_{DDP_{max}}$ | $0.26 * f_{SYS} + 5.2$ |
| | C868-1R | $I_{DDP_{typ}}$ | $0.27 * f_{SYS} + 2.7$ |
| | | $I_{DDP_{max}}$ | $0.29 * f_{SYS} + 3.9$ |
| Idle mode | C868-1S | $I_{DDP_{typ}}$ | $0.13 * f_{SYS} + 2.6$ |
| | | $I_{DDP_{max}}$ | $0.13 * f_{SYS} + 4.0$ |
| | C868-1R | $I_{DDP_{typ}}$ | $0.13 * f_{SYS} + 3.7$ |
| | | $I_{DDP_{max}}$ | $0.15 * f_{SYS} + 3.1$ |
| Active mode with slow-down enabled | C868-1S | $I_{DDP_{typ}}$ | $0.01 * f_{SYS} + 3.1$ |
| | | $I_{DDP_{max}}$ | $0.02 * f_{SYS} + 3.6$ |
| | C868-1R | $I_{DDP_{typ}}$ | $0.01 * f_{SYS} + 3.2$ |
| | | $I_{DDP_{max}}$ | $0.01 * f_{SYS} + 3.7$ |
| Idle mode with slow-down enabled | C868-1S | $I_{DDP_{typ}}$ | $0.01 * f_{SYS} + 3.0$ |
| | | $I_{DDP_{max}}$ | $0.01 * f_{SYS} + 3.8$ |
| | C868-1R | $I_{DDP_{typ}}$ | $0.02 * f_{SYS} + 2.8$ |
| | | $I_{DDP_{max}}$ | $0.02 * f_{SYS} + 3.3$ |

¹⁾ f_{SYS} is in MHz and results in mA.

**A/D Converter Characteristics
(Operating Condition Parameters)**

| Parameter | Symbol | Limits | | Unit | Test Condition |
|-------------------------------|------------|--|---|------------|--|
| | | min | max | | |
| Analog input voltage | V_{AIN} | V_{AGND} | V_{AREF} | V | 1) |
| Sample time | t_S | $64 \cdot t_{SYS}$ $52 \cdot t_{SYS}$ $48 \cdot t_{SYS}$ $40 \cdot t_{SYS}$ $32 \cdot t_{SYS}$ $24 \cdot t_{SYS}$ $16 \cdot t_{SYS}$ $8 \cdot t_{SYS}$ | $512 \cdot t_{SYS}$ $448 \cdot t_{SYS}$ $384 \cdot t_{SYS}$ $320 \cdot t_{SYS}$ $256 \cdot t_{SYS}$ $192 \cdot t_{SYS}$ $128 \cdot t_{SYS}$ $64 \cdot t_{SYS}$ | ns | Prescaler/32 Prescaler/28 Prescaler/24 Prescaler/20 Prescaler/16 Prescaler/12 Prescaler/8 Prescaler/4 |
| Conversion cycle time | t_{ADCC} | $322 \cdot t_{SYS}$ $282 \cdot t_{SYS}$ $242 \cdot t_{SYS}$ $202 \cdot t_{SYS}$ $162 \cdot t_{SYS}$ $122 \cdot t_{SYS}$ $82 \cdot t_{SYS}$ $42 \cdot t_{SYS}$ | $770 \cdot t_{SYS}$ $674 \cdot t_{SYS}$ $578 \cdot t_{SYS}$ $482 \cdot t_{SYS}$ $386 \cdot t_{SYS}$ $290 \cdot t_{SYS}$ $194 \cdot t_{SYS}$ $98 \cdot t_{SYS}$ | ns | Prescaler/32 Prescaler/28 Prescaler/24 Prescaler/20 Prescaler/16 Prescaler/12 Prescaler/8 Prescaler/4 |
| Total unadjusted error | T_{UE} | – | ± 2 ± 3 | LSB | $V_{AGND} \leq V_{AIN} \leq V_{AREF}$ ²⁾ $V_{AGND} \leq V_{AIN} \leq V_{AREF}$ ³⁾ |
| ADC input resistance | R_{AIN} | – | 1.5 | k Ω | 4)5) |
| ADC input capacitance | C_{AIN} | – | 10 | pF | 5) |
| ADC reference pin capacitance | C_{AREF} | – | 40 | pF | 5) |

Note:

- 1) V_{AIN} may exceed V_{AGND} or V_{AREF} up to the maximum ratings. However, the conversion result in these cases will be 00_H or FF_H, respectively.
- 2) T_{UE} (max.) is tested at $-20 \leq T_A \leq 125$ °C; $V_{DDP} = 3.3$ V; $V_{AREF} = V_{DDP}$ V and $V_{SSP} = V_{AGND}$. It is guaranteed by design characterization for all other voltages within the defined voltage range.
- 3) T_{UE} (max.) is tested at $-40 \leq T_A < -20$ °C; $V_{DDP} \leq 3.3$ V; $V_{AREF} = V_{DDP}$ and $V_{SSP} = V_{AGND}$. It is guaranteed by design characterization for all other voltages within the defined voltage range.

-
- 4) During the sample time the input capacitance C_{AIN} must be charged/discharged by the external source. The internal resistance of the analog source must allow the capacitance to reach their final voltage level within t_S . After the end of the sample time t_S , changes of the analog input voltage have no effect on the conversion result.
 - 5) Not 100% tested, but guaranteed by design characterization.

Clock calculation table for ADC

| | | | | | | | | | |
|-------------------------|-----|-----|-----|-----|-----|-----|-----|-----|----------------|
| TVC¹⁾ | 32 | | | | | | | | |
| STC²⁾ | 2 | 4 | 6 | 8 | 10 | 12 | 14 | 16 | $t_{ADC}^{3)}$ |
| t_{ADCC} | 322 | 386 | 450 | 514 | 578 | 642 | 706 | 770 | t_{SYS} |
| t_S | 64 | 128 | 192 | 256 | 320 | 384 | 448 | 512 | t_{SYS} |

| | | | | | | | | | |
|-------------------------|-----|-----|-----|-----|-----|-----|-----|-----|----------------|
| TVC¹⁾ | 28 | | | | | | | | |
| STC²⁾ | 2 | 4 | 6 | 8 | 10 | 12 | 14 | 16 | $t_{ADC}^{3)}$ |
| t_{ADCC} | 282 | 338 | 394 | 450 | 506 | 562 | 618 | 674 | t_{SYS} |
| t_S | 56 | 112 | 168 | 224 | 280 | 336 | 392 | 448 | t_{SYS} |

| | | | | | | | | | |
|-------------------------|-----|-----|-----|-----|-----|-----|-----|-----|----------------|
| TVC¹⁾ | 24 | | | | | | | | |
| STC²⁾ | 2 | 4 | 6 | 8 | 10 | 12 | 14 | 16 | $t_{ADC}^{3)}$ |
| t_{ADCC} | 242 | 290 | 338 | 386 | 434 | 482 | 530 | 578 | t_{SYS} |
| t_S | 48 | 96 | 144 | 192 | 240 | 288 | 336 | 384 | t_{SYS} |

| | | | | | | | | | |
|-------------------------|-----|-----|-----|-----|-----|-----|-----|-----|----------------|
| TVC¹⁾ | 20 | | | | | | | | |
| STC²⁾ | 2 | 4 | 6 | 8 | 10 | 12 | 14 | 16 | $t_{ADC}^{3)}$ |
| t_{ADCC} | 202 | 242 | 282 | 322 | 362 | 402 | 442 | 482 | t_{SYS} |
| t_S | 40 | 80 | 120 | 160 | 200 | 240 | 280 | 320 | t_{SYS} |

| | | | | | | | | | |
|-------------------------|-----|-----|-----|-----|-----|-----|-----|-----|----------------|
| TVC¹⁾ | 16 | | | | | | | | |
| STC²⁾ | 2 | 4 | 6 | 8 | 10 | 12 | 14 | 16 | $t_{ADC}^{3)}$ |
| t_{ADCC} | 162 | 194 | 226 | 258 | 290 | 322 | 354 | 386 | t_{SYS} |
| t_S | 32 | 64 | 96 | 128 | 160 | 192 | 224 | 256 | t_{SYS} |

| | | | | | | | | | |
|-------------------------|-----|-----|-----|-----|-----|-----|-----|-----|----------------|
| TVC¹⁾ | 12 | | | | | | | | |
| STC²⁾ | 2 | 4 | 6 | 8 | 10 | 12 | 14 | 16 | $t_{ADC}^{3)}$ |
| t_{ADCC} | 122 | 146 | 170 | 194 | 218 | 242 | 266 | 290 | t_{SYS} |
| t_S | 24 | 48 | 72 | 96 | 120 | 144 | 168 | 192 | t_{SYS} |

| TVC¹⁾ | 8 | | | | | | | | |
|------------------------------|----------|----|-----|-----|-----|-----|-----|-----|----------------|
| STC²⁾ | 2 | 4 | 6 | 8 | 10 | 12 | 14 | 16 | $t_{ADC}^{3)}$ |
| t_{ADCC} | 82 | 98 | 114 | 130 | 146 | 162 | 178 | 194 | t_{SYS} |
| t_S | 16 | 32 | 48 | 64 | 80 | 96 | 112 | 128 | t_{SYS} |

| TVC¹⁾ | 4 | | | | | | | | |
|------------------------------|----------|----|----|----|----|----|----|----|----------------|
| STC²⁾ | 2 | 4 | 6 | 8 | 10 | 12 | 14 | 16 | $t_{ADC}^{3)}$ |
| t_{ADCC} | 42 | 50 | 58 | 66 | 74 | 82 | 90 | 98 | t_{SYS} |
| t_S | 8 | 16 | 24 | 32 | 40 | 48 | 56 | 64 | t_{SYS} |

1) TVC is the clock divider specified by bit fields ADCTC.

2) STC is the sample time control specified by bit fields ADSTC.

3) t_{ADC} is $t_{SYS} * TVC$

AC Characteristics

(Operating Condition Apply)

External Clock Drive Characteristics

| Parameter | Symbol | Limit Values | | Unit |
|--------------------|-----------|---|-----|------|
| | | Variable Ext Clock 6.67 to 10.67 MHz | | |
| | | min | max | |
| Oscillating period | t_{OSC} | 93.75 | 150 | ns |
| High time | t_H | 46.875 | 75 | ns |
| Low time | t_L | 46.875 | 75 | ns |
| Rise time | t_R | - | 10 | ns |
| Fall time | t_F | - | 10 | ns |

ALE Characteristics

| Parameter | Symbol | Limit Values | | Unit |
|-----------------|-----------|--|-----|------|
| | | System freq = 6.25MHz to 40MHz Duty Cycle 0.5 | | |
| | | min | max | |
| ALE pulse width | t_{AWD} | 50 | 320 | ns |
| ALE period | t_{ACY} | 150 | 960 | ns |

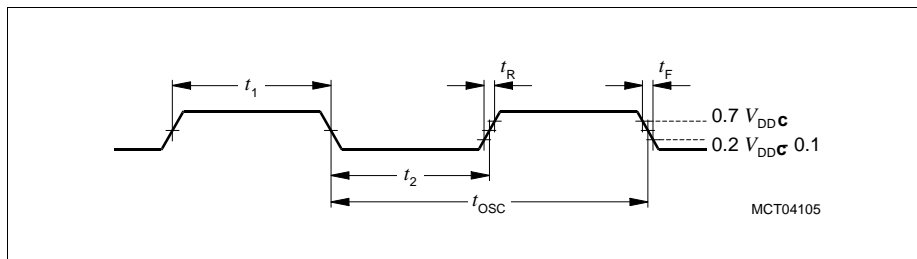

Figure 30 External Clock Drive on XTAL2

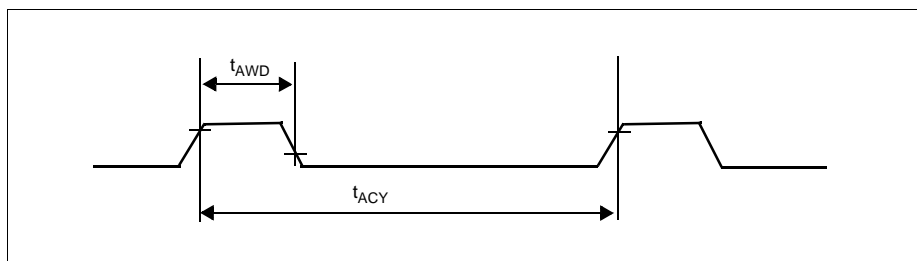

Figure 31 ALE Characteristic

Package Outlines

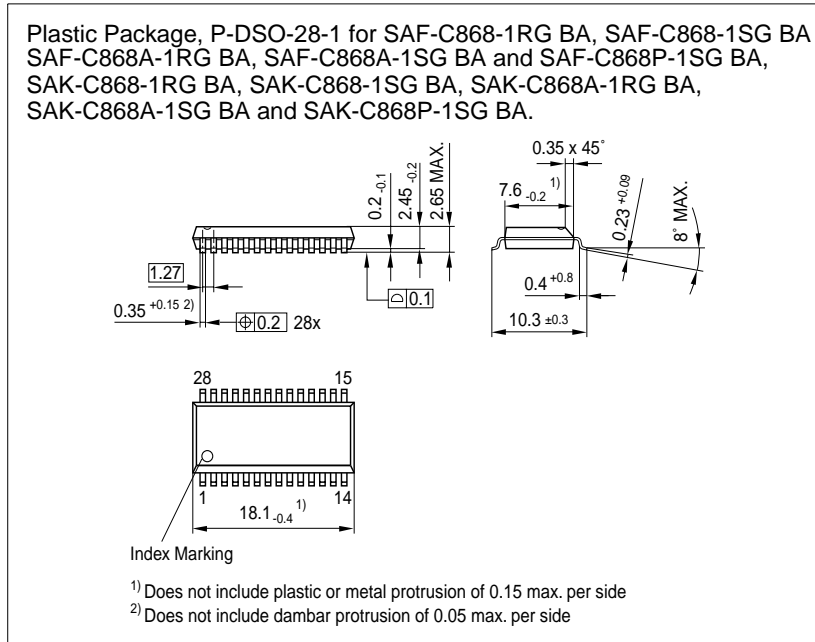

Figure 32 DSO-28-1 Package Outlines

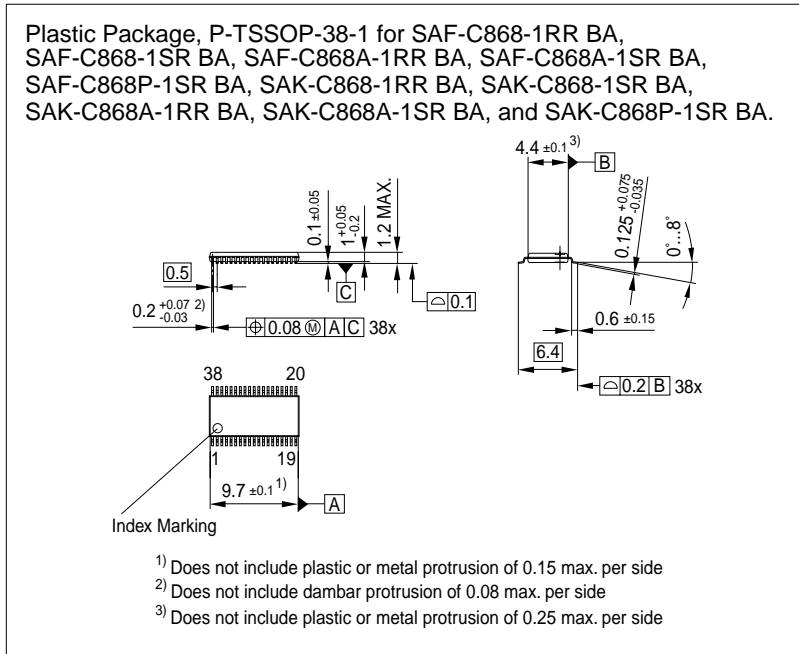



Figure 33 TSSOP-38-1 Package Outlines



Infineon goes for Business Excellence

“Business excellence means intelligent approaches and clearly defined processes, which are both constantly under review and ultimately lead to good operating results.

Better operating results and business excellence mean less idleness and wastefulness for all of us, more professional success, more accurate information, a better overview and, thereby, less frustration and more satisfaction.”

Dr. Ulrich Schumacher

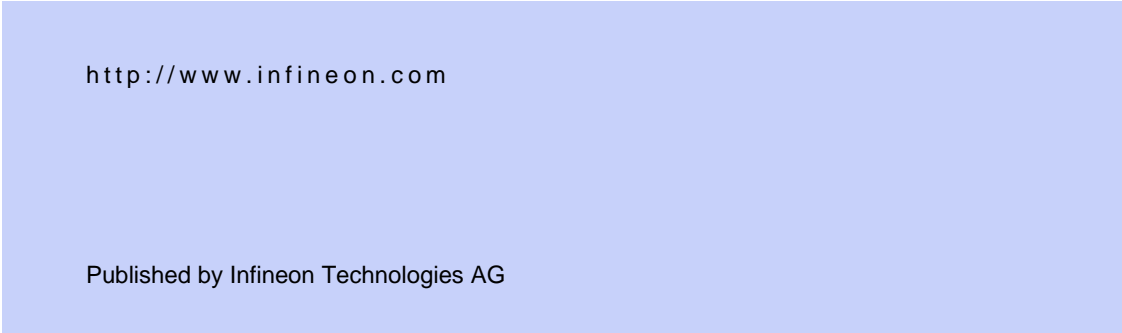

<http://www.infineon.com>

Published by Infineon Technologies AG

Looking for pricing, stock, or lifecycle information?

Click below to explore more details on WIN SOURCE:

- ⊖ [View SAK-C868-1SR BA on WIN SOURCE](#)
- ⊖ [Infineon Technologies](#) Information

Optimize Your Supply Chain with WIN SOURCE Solutions

- ✓ Global Sourcing Solution
- ✓ Obsolete Management
- ✓ Cost Control Management
- ✓ Shortage Management
- ✓ Alternative Solution
- ✓ Excess Inventory Management