



**THE DATASHEET OF
D2514-6002-AR**



3M™ FOUR-WALL HEADER, D2500 SERIES

.100" X .100" LOW PROFILE, SURFACE MOUNT, STRAIGHT AND RIGHT ANGLE THROUGH-HOLE

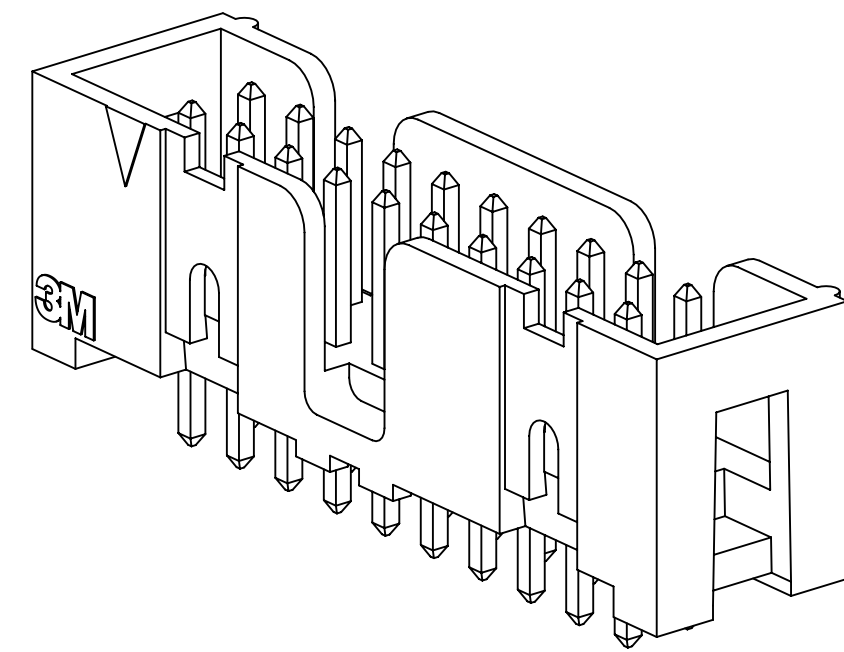

D25XX-6002
STRAIGHT VERSION

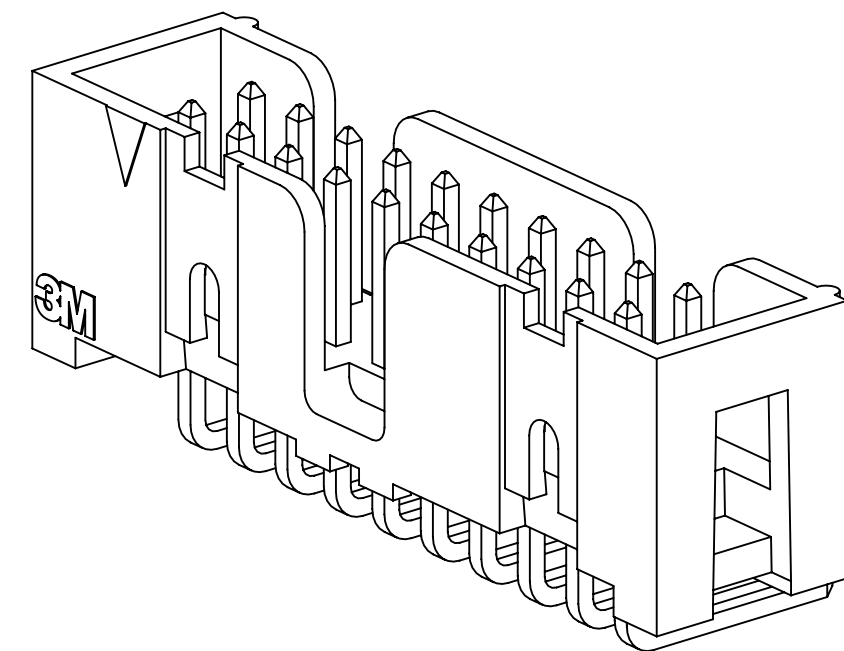

D25XX-5002
RIGHT ANGLE VERSION

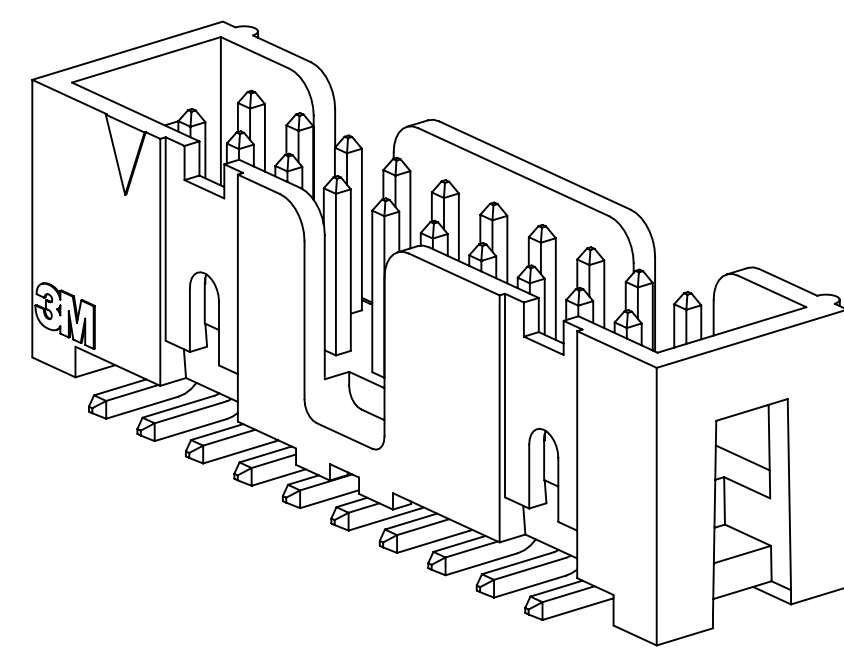

D25XX-6VOC
SURFACE MOUNT VERSION

- * LOW PROFILE, SPACE SAVING DESIGN.
- * CENTER SLOT POLARIZATION PREVENTS MIS-INSERTIONS AND REDUCES INSERTION TIME.
- * DUAL SLOT POLARIZATION MEANS BROADER COMPATIBILITY WITH COMPETITIVE POLARIZATION DESIGNS (NOT AVAILABLE ON 6, 8 OR 10 POSITIONS).
- * OPTIONAL RETAINER CLIP FOR LOCKING SOCKETS IN PLACE AND INCREASING CONNECTION RELIABILITY IN VIBRATION-PRONE ENVIRONMENTS.
- * HIGH TEMPERATURE INSULATOR SUITABLE FOR "NO LEAD" SOLDERING OPERATIONS.
- * THROUGH HOLE VERSION SUITABLE FOR REFLOW SOLDERING USING "PASTE IN HOLE" TECHNIQUES.
- * EXPOSED SOLDER TAILS (ON RIGHT ANGLE VERSION) PROVIDE EASE OF CLEANING AND REDUCED REPAIR COST.
- * STRAIGHT SURFACE MOUNT VERSION AVAILABLE.

2 PHYSICAL :

INSULATOR:
 MATERIAL: HIGH TEMP GLASS FILLED POLYESTER (PCT)
 FLAMMABILITY: UL94V-0
 COLOR: BLACK
 CONTACT:
 MATERIAL: BRASS
 PLATING:
 UNDER PLATING: 50-100µ" [1.27-2.54µm] NICKEL-OVERALL
 WIPING AREA: 10µ" [25µm] GOLD
 SOLDER TAILS: 40-120µ" [1-3µm] MATTE TIN
 MARKINGS: 3M LOGO, PART IDENTIFICATION NUMBER AND ORIENTATION TRIANGLE

2 ELECTRICAL :

CURRENT RATING: 5.00A, 1 CONTACT POWERED
 3.00A, 6 CONTACTS POWERED
 1.75A, ALL CONTACTS POWERED
 RATING CONDITIONS: EIA-364-070 METHOD 2, 30°C MAXIMUM TEMPERATURE RISE, 20% DERATED. REFERENCE APPROPRIATE 3M PRODUCT SPECIFICATION FOR DETAILED CURRENT DERATING CURVES.
 INSULATION RESISTANCE: >1 X 10⁹Ω AT 500 V_{DC}
 WITHSTANDING VOLTAGE: 1,000V_{RMS} AT SEA LEVEL

2 ENVIRONMENTAL :

TEMPERATURE RATING: -55°C TO 105°C
 PROCESS RATING: 260°C, PER J-STD-020C, SINGLE PASS
 MOISTURE SENSITIVITY LEVEL: 1 (PER J-STD-020C)

- NOTES
1. REGULATORY INFORMATION: ROHS COMPLIANT. SEE THE REGULATORY INFORMATION APPENDIX (RIA) IN THE "ROHS COMPLIANCE" SECTION OF WWW.3MCONNECTORS.COM FOR COMPLIANCE INFORMATION.
 2. IN THE EVENT OF CONFLICT BETWEEN THIS DATA AND THAT CONTAINED IN THE PRODUCT SPECIFICATION, THE PRODUCT SPECIFICATION TAKES PRECEDENT.
 3. NOTCHES A & C WILL ACCOMMODATE 3M POLARIZING KEY: N3518.
 4. CONTACT TAILS .0245 [.622] WIRE WITH .0075 [.191] CORNER RADIUS AND .028 [.072] DIAGONAL.
 5. SOLDER STANDOFFS FACILITATE .01 [.3] CLEARANCE ABOVE BOARD FOR REFLOW SOLDERING.

3M ELECTRONIC MATERIALS SOLUTIONS DIVISION
 INTERCONNECT SOLUTIONS
<http://www.3mconnectors.com>

3M IS A TRADEMARK OF 3M COMPANY.
 FOR TECHNICAL, SALES OR ORDERING
 INFORMATION CALL 800-225-5373

3M
 UL FILE NO: E68080

DIMENSIONS: INCHES [MM]
 [MM] IS REF. ONLY

DESIGN REFERENCE	NEXT ASSEMBLY	REV	ECO	ISSUE DATE AND DESCRIPTION	DRFT	CHKD
				AUG 05, 2016 REVISED AND REDRAWN	JNC	SC
DATE	DATE	DATE	DATE	DATE	DATE	DATE
				AUG 05, 2016		AUG 05, 2016
APPRV	APPRV	APPRV	APPRV	APPRV	APPRV	APPRV
				S. CLATANOFF		
DIVISION	DIVISION CODE	© 3M COPYRIGHT 2016 This document and the information it contains are 3M property and may not be reproduced or further distributed without 3M permission, or used or disclosed other than for 3M authorized purposes. All rights reserved.				
Interconnect Solutions	EMSD	3M Center St. Paul, MN 55144				
DO NOT SCALE DRAWING	SCALE 4/1	TOLERANCES EXCEPT AS NOTED INCHES .0 ± .01 .000 ± .005 .0000 ±				
THIRD ANGLE PROJECTION	INTERPRET PER ASME Y14.5 - 2009	MILLIMETERS 0 ± .0 ± .3 .00 ± .13 .000 ±				
MAX SURFACE ROUGHNESS	DTX SURFACES	CAGE NUMBER D 78-5100-2244-1 H				
MARKED ONLY	ANGLES	MODEL D2500 SERIES				
		DET. YES <input type="checkbox"/> NO <input type="checkbox"/> SHT 1 OF 5				

H REVISION
 78-5100-2244-1 DRAWING NUMBER
 B
 A
 Imaged: H.1 B/5/2016 11:12 AM UTC-05:00

3M™ FOUR-WALL HEADER, D2500 SERIES
 .100" X .100" LOW PROFILE, SURFACE MOUNT, STRAIGHT AND RIGHT ANGLE THROUGH-HOLE

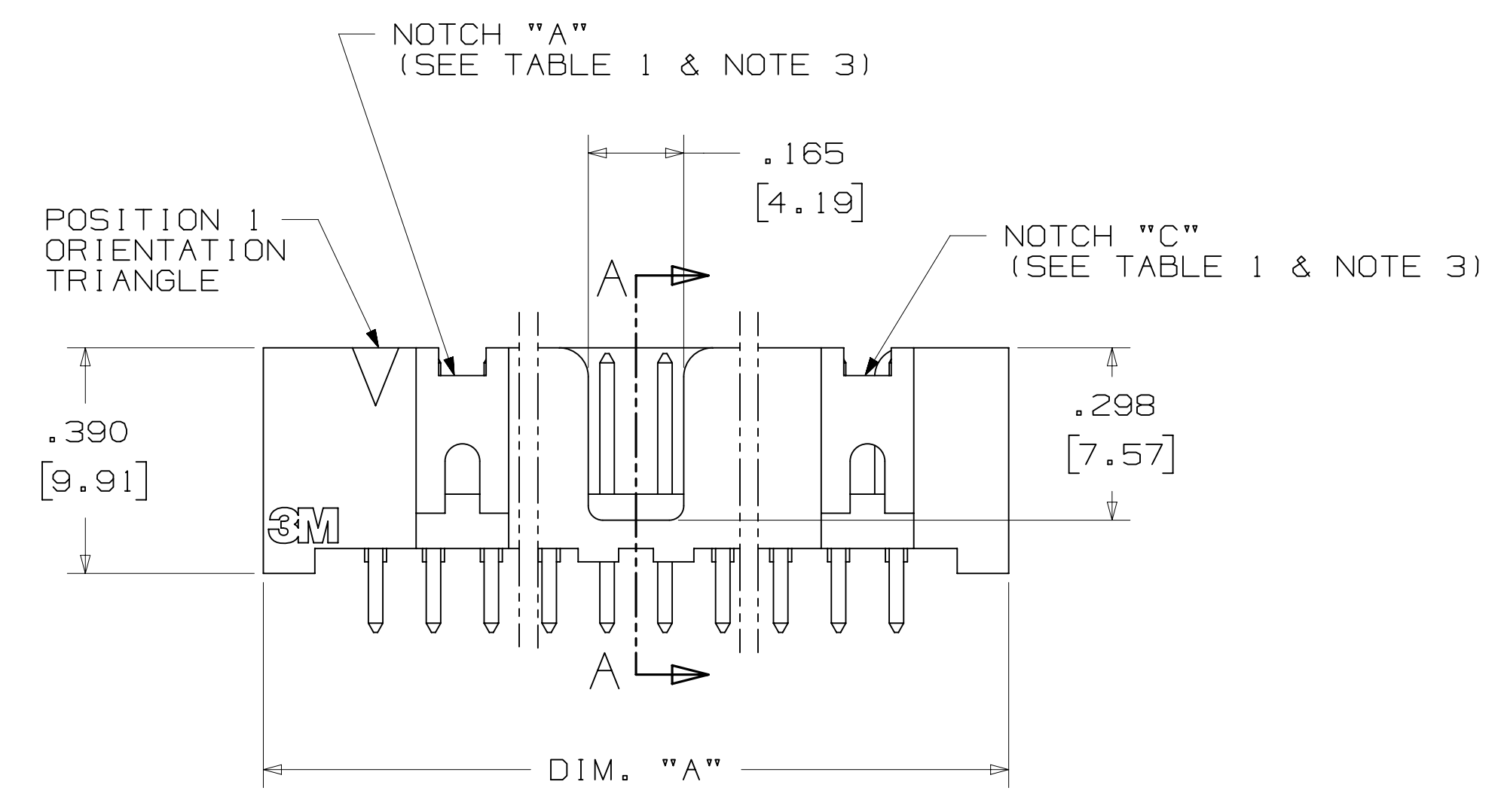
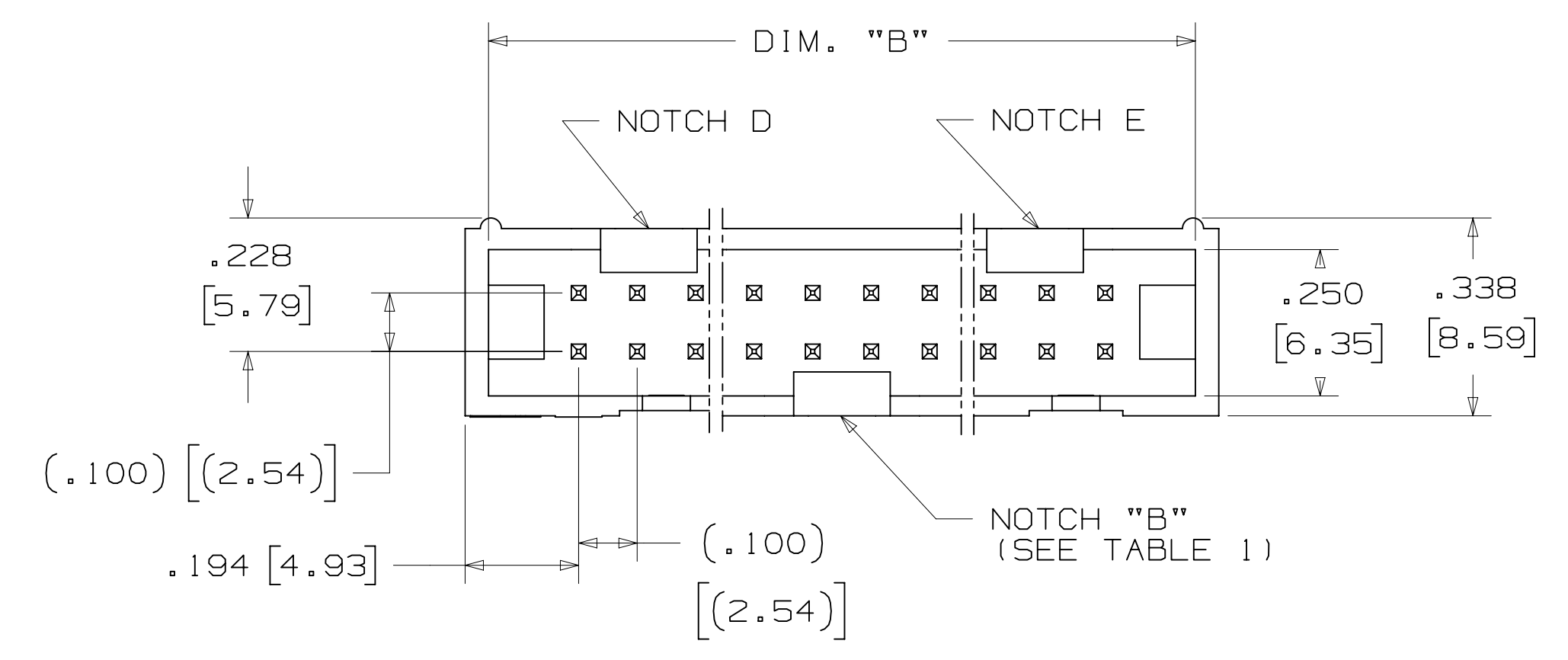
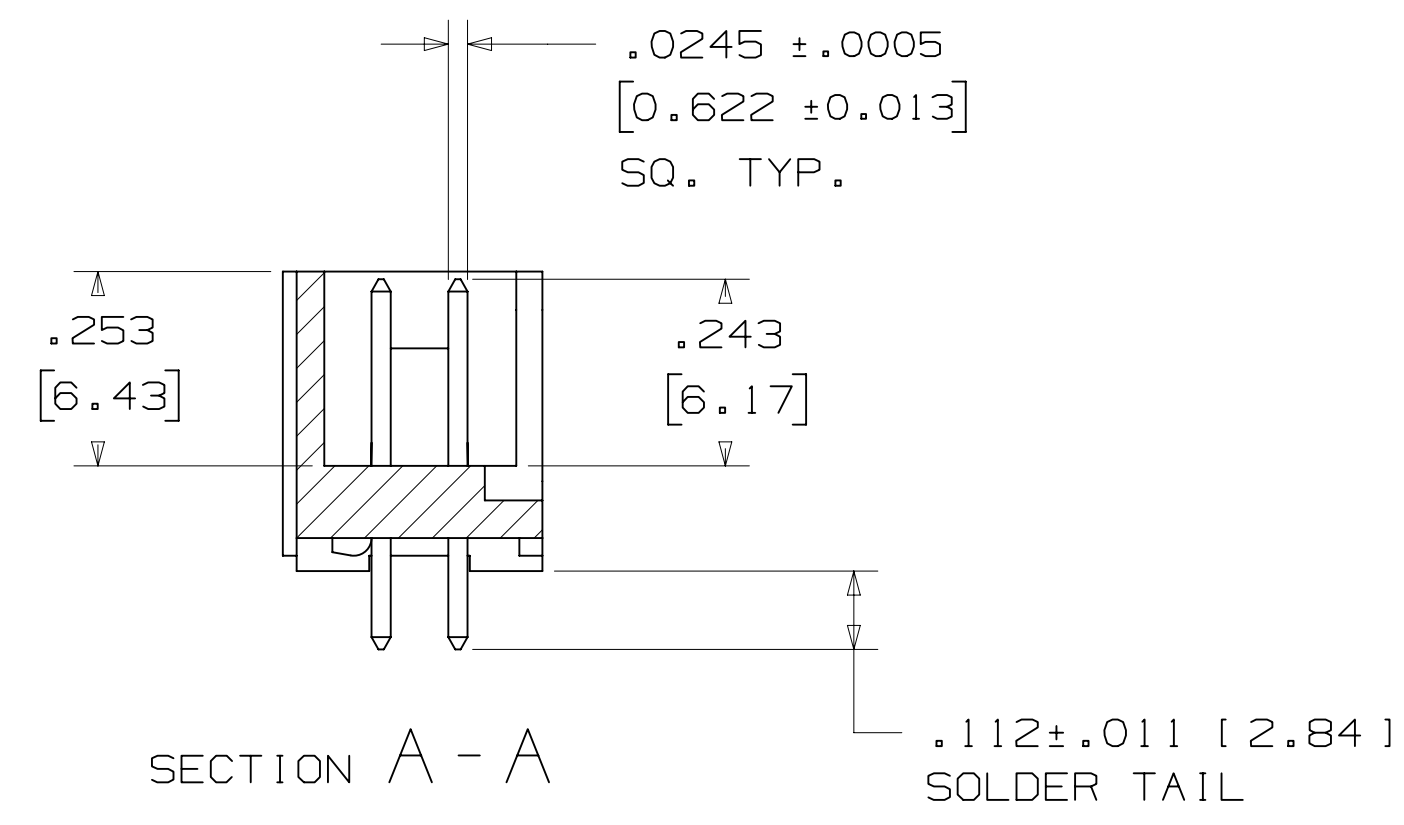
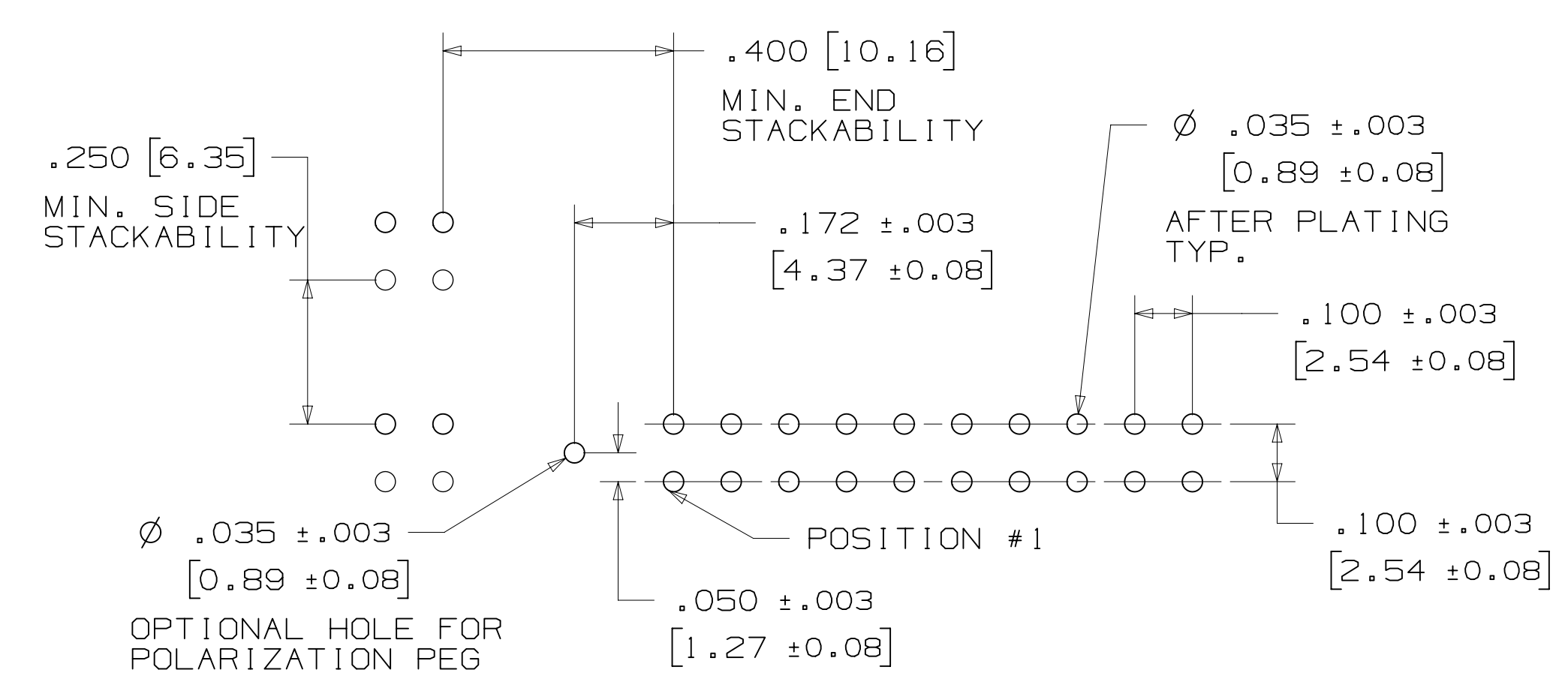

TABLE 1				
PIN QTY.	DIM. "A"	DIM. "B"	POLARIZING NOTCHES	PIN QTY.
06	.588 [14.94]	.508 [12.90]	B	06
08	.688 [17.48]	.608 [15.44]	B	08
10	.788 [20.02]	.708 [17.98]	BC	10
14	.988 [25.10]	.908 [23.06]	BCDE	14
16	1.088 [27.64]	1.008 [25.60]	ABCDE	16
20	1.288 [32.72]	1.208 [30.68]	ABCDE	20
24	1.488 [37.80]	1.408 [35.76]	ABCDE	24
26	1.588 [40.34]	1.508 [38.30]	ABCDE	26
30	1.788 [45.42]	1.708 [43.38]	ABCDE	30
34	1.988 [50.50]	1.908 [48.46]	ABCDE	34
36	2.088 [53.04]	2.008 [51.00]	ABCDE	36
40	2.288 [58.12]	2.208 [56.08]	ABCDE	40
50	2.788 [70.82]	2.708 [68.78]	ABCDE	50
60	3.288 [83.52]	3.208 [81.48]	ABCDE	60
64	3.488 [88.60]	3.408 [86.56]	ABCDE	64



ORDERING INFORMATION
 STRAIGHT VERSION

D25XX-6002-AR

PIN QUANTITY: (SEE TABLE 1)
 SOLDER TAIL: FOR .062 [1.57] THICK BOARD
 PLATING: AR = 10µ" [0.25µm] GOLD (RIA, E1 & C1 APPLY)

RECOMMENDED HOLE PATTERN
 SHOWN FROM COMPONENT SIDE

DESIGN REFERENCE	NEXT ASSEMBLY	REV	ECO	ISSUE DATE AND DESCRIPTION	DRFT	CHKD
				AUG 05, 2016		
DIVISION: Interconnect Solutions		DIVISION CODE: EMSD		DATE: AUG 05, 2016		
DO NOT SCALE DRAWING		SCALE: 4/1		TOLERANCES EXCEPT AS NOTED		
THIRD ANGLE PROJECTION		INCHES: .00 ± .01, .000 ± .005, .0000 ±		MILLIMETERS: 0 ±, .0 ± .3, .00 ± .13, .000 ±		
INTERPRET PER ASME Y14.5 - 2009		MAX SURFACE ROUGHNESS: SURFACES		CAGE NUMBER: D2500 SERIES		
MARKED ONLY		ANGLES		TITLE: HEADER, 4-WALL, LO-PRO, .100 X .100, SMT, STRAIGHT & RA		
				CAGE NUMBER: D2500 SERIES		
				REV. H		
				SHT 2 OF 5		

78-5100-2244-1
 DRAWING NUMBER
 H
 REVISION
 AUG 05, 2016
 DATE
 S. CLATANOFF
 APPR
 AUG 05, 2016
 DATE
 H
 REV.
 H
 SHT 2 OF 5

3M™ FOUR-WALL HEADER, D2500 SERIES
 .100" X .100" LOW PROFILE, SURFACE MOUNT, STRAIGHT AND RIGHT ANGLE THROUGH-HOLE

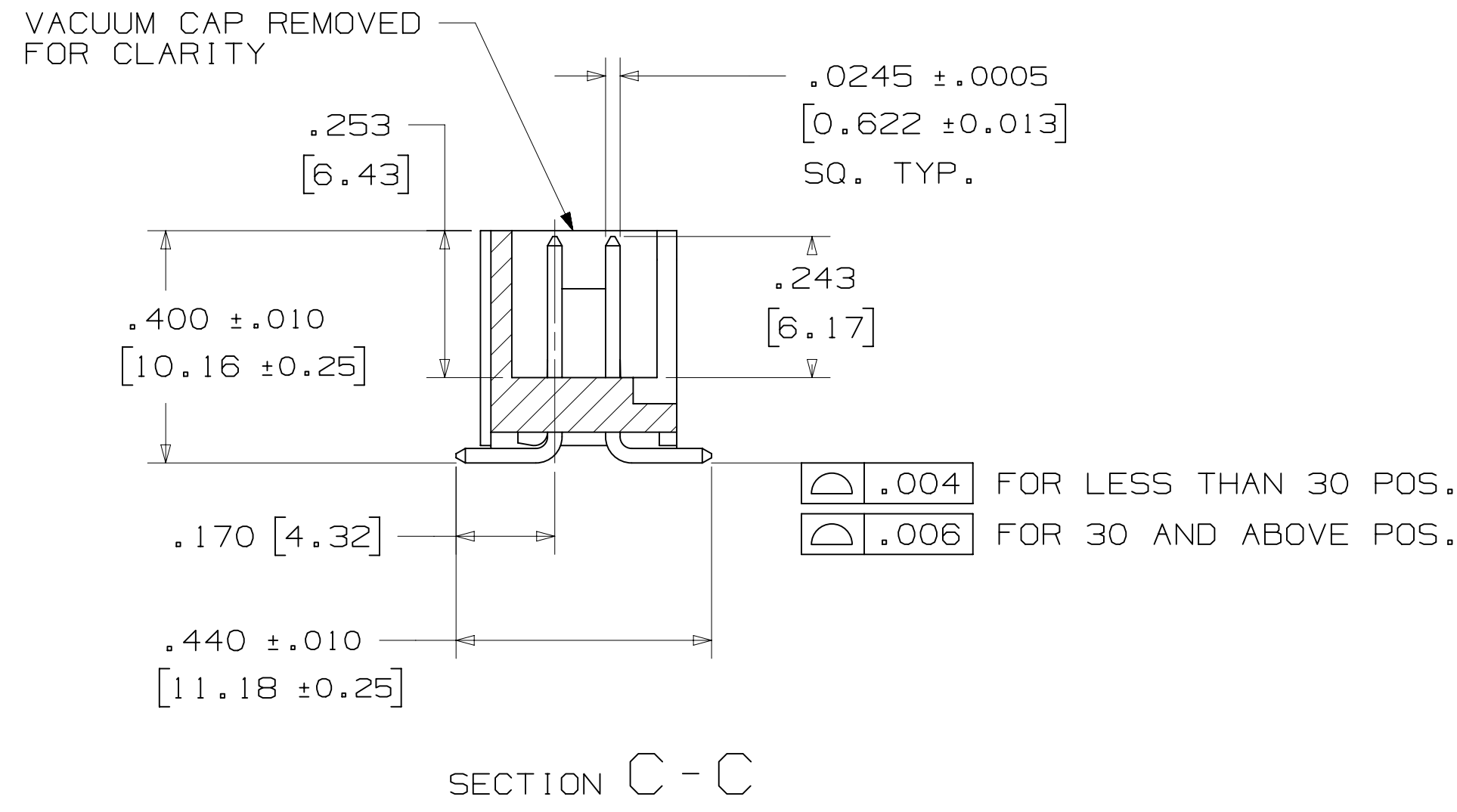

TABLE 1					
PIN QTY.	DIM. "A"	DIM. "B"	POLARIZING NOTCHES	TAPE AND REEL PKG CODE	PIN QTY.
06	.588 [14.94]	.508 [12.90]	B	WD (44 MM)	06
08	.688 [17.48]	.608 [15.44]	B	WD (44 MM)	08
10	.788 [20.02]	.708 [17.98]	BC	WD (44 MM)	10
14	.988 [25.10]	.908 [23.06]	BCDE	WD (44 MM)	14
16	1.088 [27.64]	1.008 [25.60]	ABCDE	WD (44 MM)	16
20	1.288 [32.72]	1.208 [30.68]	ABCDE	WE (56 MM)	20
24	1.488 [37.80]	1.408 [35.76]	ABCDE	WE (56 MM)	24
26	1.588 [40.34]	1.508 [38.30]	ABCDE	WE (56 MM)	26
30	1.788 [45.42]	1.708 [43.38]	ABCDE	WF (72 MM)	30
34	1.988 [50.50]	1.908 [48.46]	ABCDE	WF (72 MM)	34
36	2.088 [53.04]	2.008 [51.00]	ABCDE	WG (88 MM)	36
40	2.288 [58.12]	2.208 [56.08]	ABCDE	WG (88 MM)	40
50	2.788 [70.82]	2.708 [68.78]	ABCDE	WG (88 MM)	50
60	3.288 [83.52]	3.208 [81.48]	ABCDE	WH (120 MM)	60
64	3.488 [88.60]	3.408 [86.56]	ABCDE	WH (120 MM)	64

ORDERING INFORMATION
 SURFACE MOUNT VERSION
 D25XX-6VOC-AR-XX

PIN QUANTITY:
 (SEE TABLE 1)

PACKAGING OPTIONS:
 WX = TAPE & REEL PACKAGING (SEE TABLE 1)

PLATING:
 AR = 10μ" [0.25μm] GOLD
 (RIA, E1 & C1 APPLY)

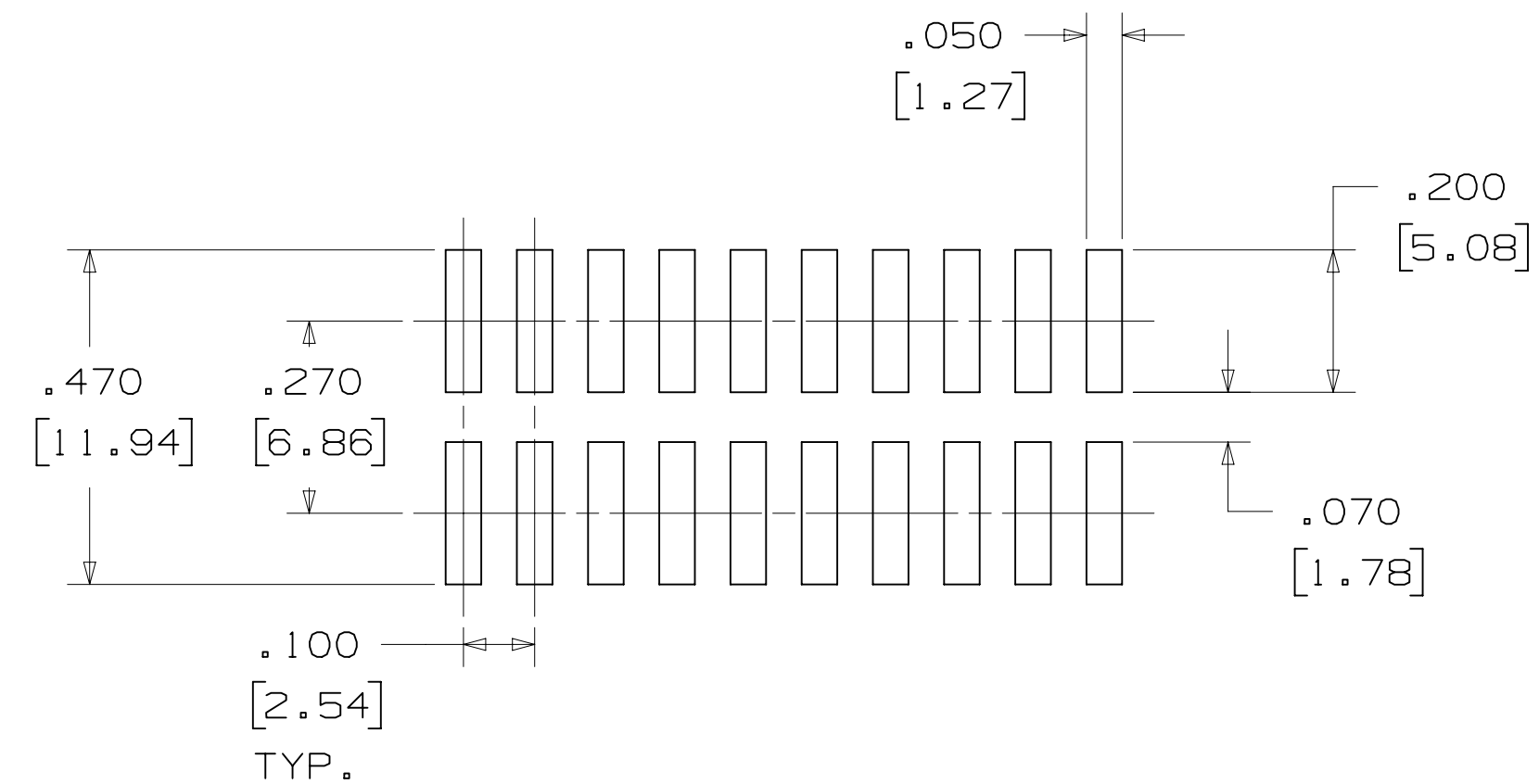
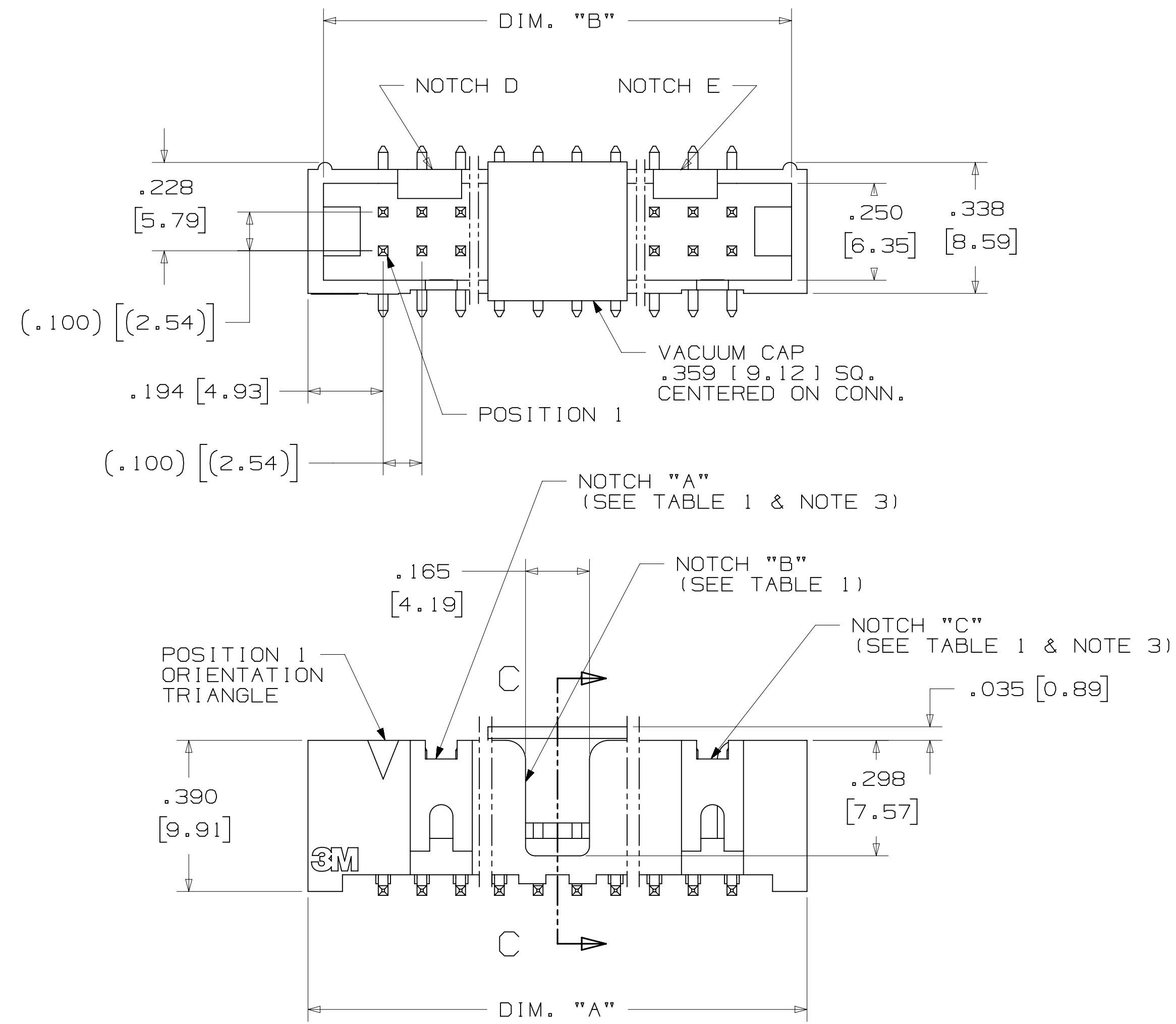

RECOMMENDED PAD LAYOUT

DESIGN REFERENCE	NEXT ASSEMBLY	REV	ECO	ISSUE DATE AND DESCRIPTION	DRFT	CHKD
				AUG 05, 2016		
DO NOT SCALE DRAWING	SCALE 4/1	TOLERANCES EXCEPT AS NOTED		INCHES .00 ±.01 .000 ±.005 .0000 ±		
THIRD ANGLE PROJECTION	INTERPRET PER ASME Y14.5 - 2009	MILLIMETERS		0 ± .00 ±.13 .000 ±		
MAX SURFACE ROUGHNESS	DT SURFACES	MARKED ONLY		ANGLE ±		
DIVISION: Interconnect Solutions CAGE NUMBER: D78-5100-2244-1 MODEL: D2500 SERIES		DIVISION CODE: EMSD DATE: AUG 05, 2016 APPR: S. CLATANOFF DATE: AUG 05, 2016		TITLE: HEADER, 4-WALL, LO-PRO, .100 X .100, SMT, STRAIGHT & RA REV. H SHEET 4 OF 5		

78-5100-2244-1
 H
 REV. H.1 B/5/2016 11:12 AM UTC-05:00

3M™ FOUR-WALL HEADER, D2500 SERIES
 .100" X .100" LOW PROFILE, SURFACE MOUNT, STRAIGHT AND RIGHT ANGLE THROUGH-HOLE

PART CUSTOMIZATION

THIS SPEC SHEET DETAILS OUR STANDARD OFFERING.

3M HAS SEVERAL CAPABILITIES THAT CAN PROVIDE A PART TAILORED TO YOUR SPECIFIC NEEDS. ASK YOUR 3M SALES REPRESENTATIVE OR CUSTOMER SERVICE FOR MORE DETAILS.

- * SELECTIVE PIN REMOVAL (FOR BOARD ASSEMBLY POLARIZATION).
- * DIFFERENT PIN LENGTHS.

POLARIZING KEY

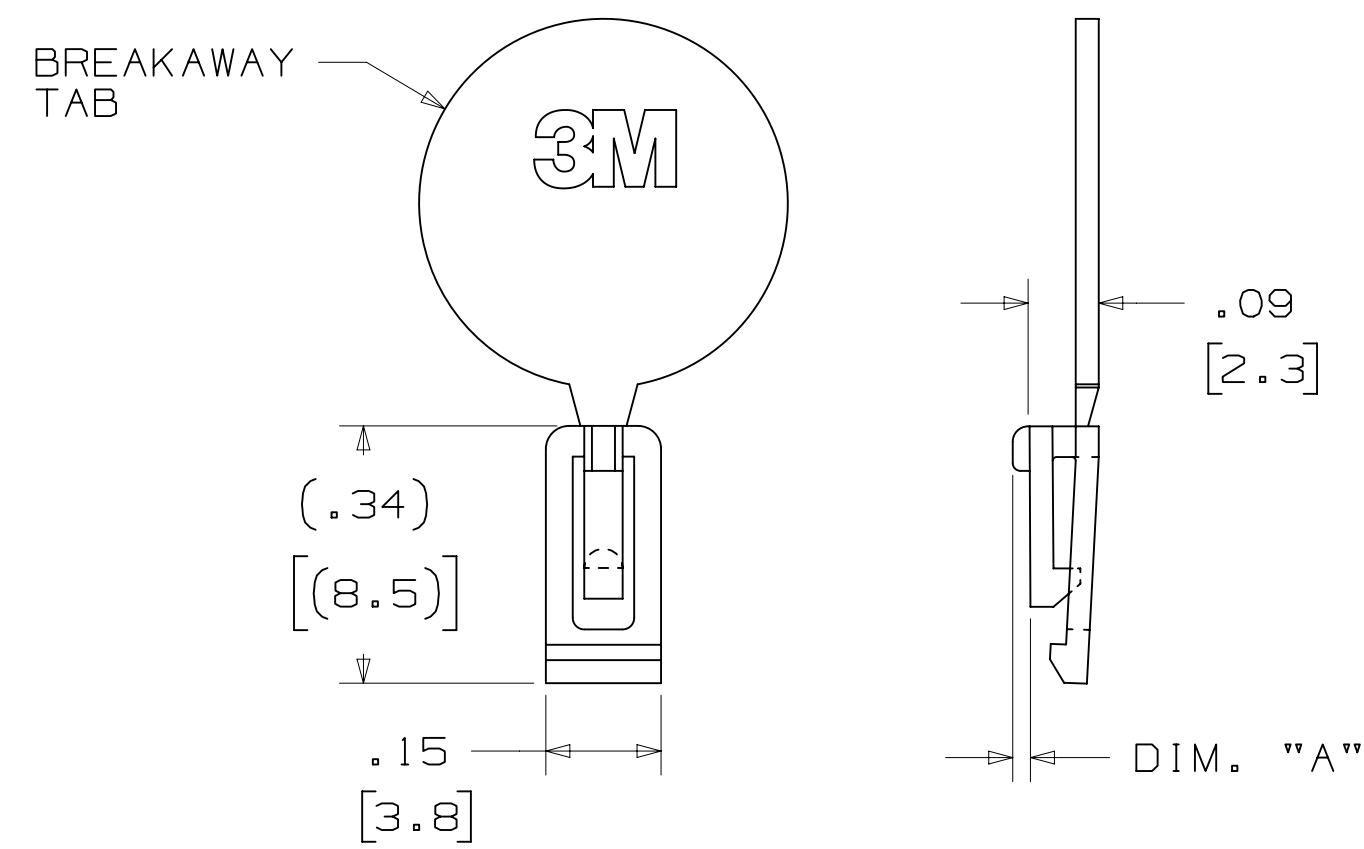

3M PART NO.	MATERIAL	COLOR	DIM. "A"
N3518	LCP	BLACK	.02

NOTE:
 #2216 B/A SCOTCHWELD CAN BE USED TO ADHERE KEYS.

LOW PROFILE LATCH

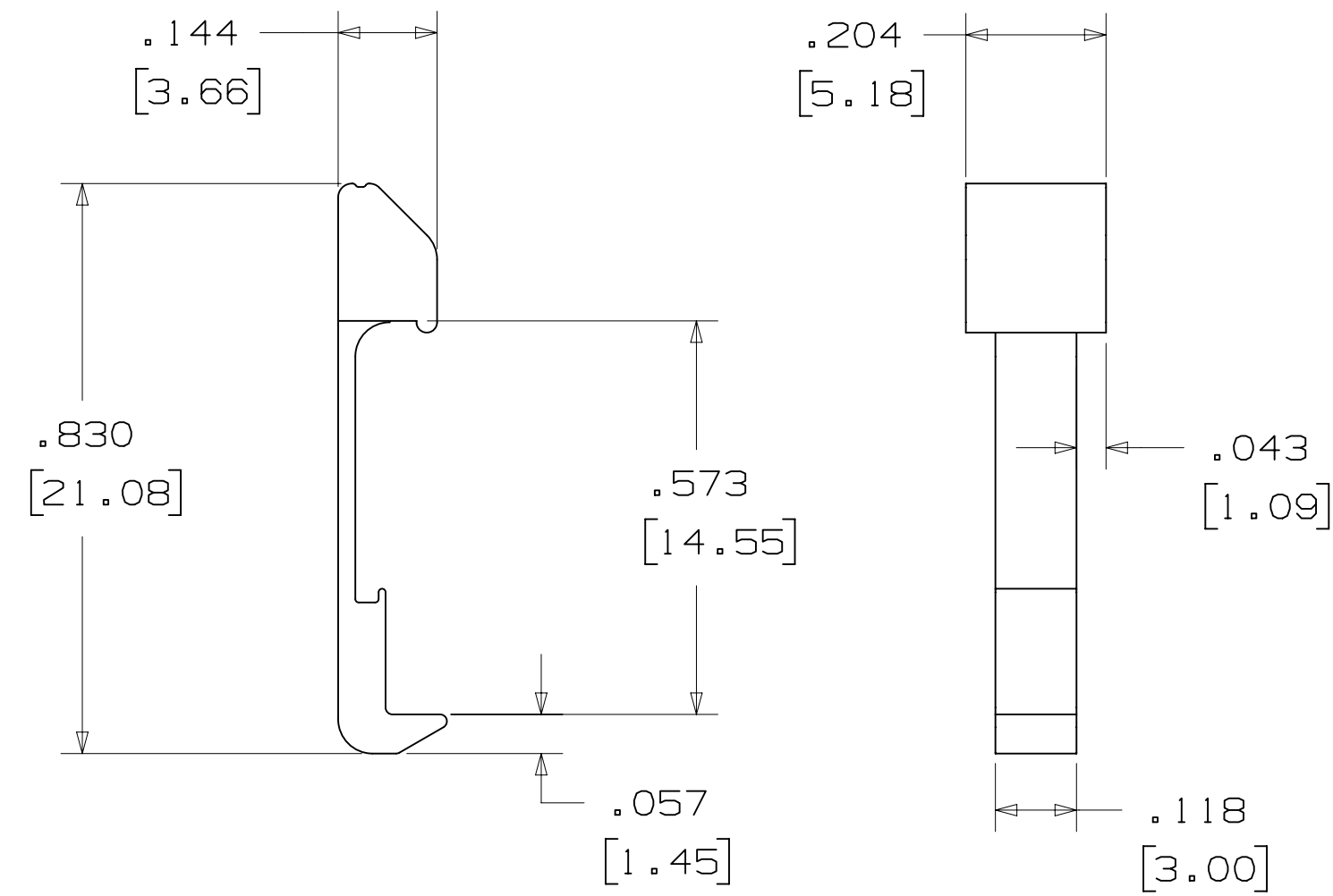

PART NO.	MATERIAL	COLOR
3505-33B	NYLON	BLACK

NOTE:
 LATCHES NOT COMPATIBLE WITH REFLOW SOLDERING.
 ATTACH LATCHES AFTER SOLDERING.

POLARIZING POST

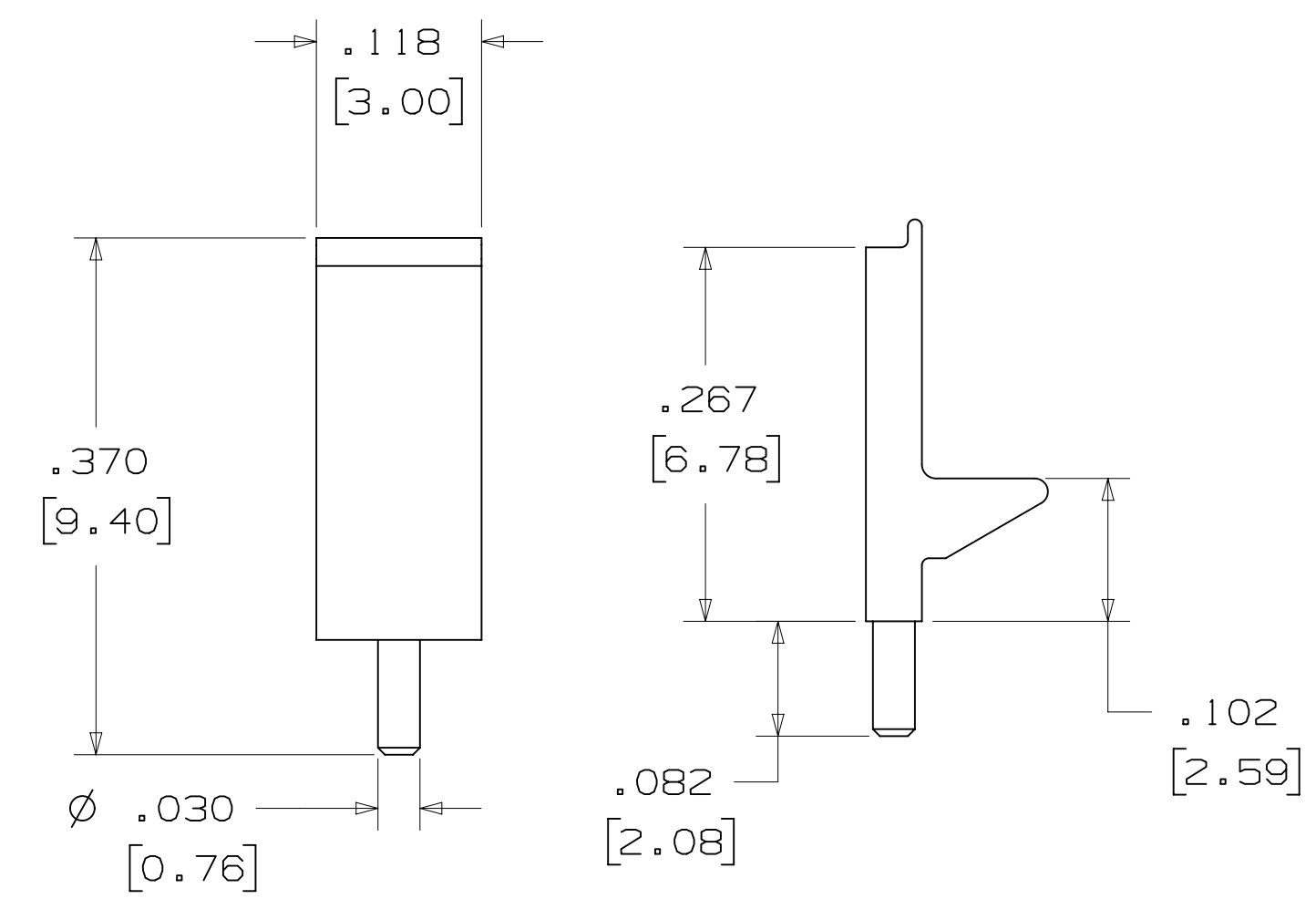

PART NO.	MATERIAL	COLOR
3201-3	PCT	BLACK

SHORT/LONG SOCKET RETAINER CLIP

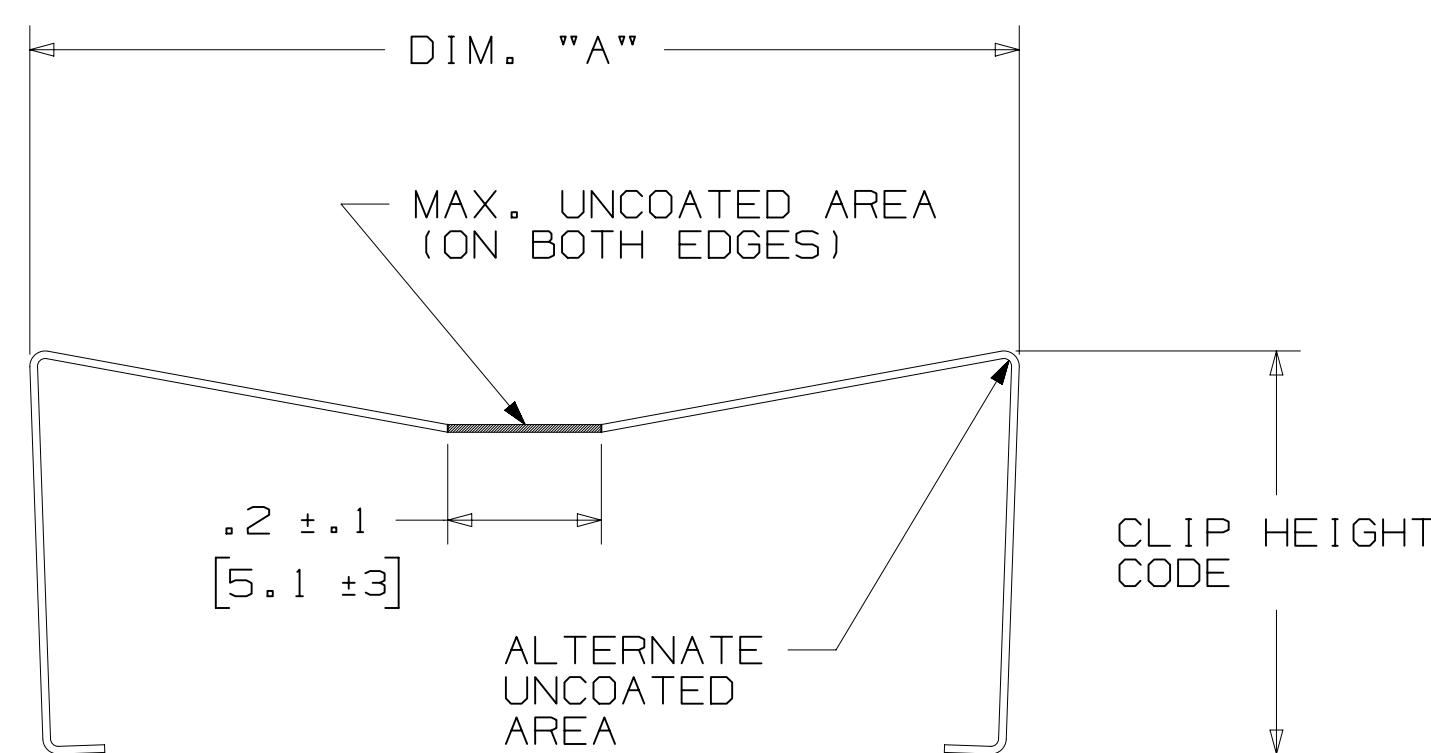

PIN QTY.	DIM. "A"
06	N/A
08	N/A
10	.81 [20.6]
14	1.02 [25.9]
16	1.12 [28.4]
20	1.32 [33.5]
24	1.52 [38.7]
26	1.63 [41.4]
30	1.83 [46.4]
34	2.03 [51.6]
36	N/A
40	2.33 [59.2]
50	2.83 [71.9]
60	3.33 [84.6]
64	3.53 [89.7]

NOTE:
 STAINLESS STEEL WITH GRAY POLYURETHANE COATING.

3505-8XXX

CLIP HEIGHT CODE _____ PIN COUNT (SEE TABLE)
 0 = .31 [7.9] FOR SOCKETS WITHOUT STRAIN RELIEF
 1 = .53 [13.5] FOR SOCKETS WITH STRAIN RELIEF

NOTE:
 1) THE FOLLOWING RETAINER CLIPS HAVE BEEN DISCONTINUED:
 3505-8064
 3505-8124
 3505-8150

DESIGN REFERENCE	NEXT ASSEMBLY	REV	ECO	ISSUE DATE AND DESCRIPTION	DRFT	CHKD
				AUG 05, 2016 REVISED AND REDRAWN	JNC	SC
APPROVED	DATE	DATE	DATE	DATE	DATE	DATE
CASTIGLIONE	AUG 05, 2016	MFG				
		APPRV	DATE	DATE	DATE	DATE
		S. CLATANOFF	AUG 05, 2016			
DIVISION	DIVISION CODE	© 3M COPYRIGHT 2016 This document and the information it contains are 3M property and may not be reproduced or further distributed without 3M permission, or used or disclosed other than for 3M authorized purposes. All rights reserved.				
Interconnect Solutions	EMSD	3M Center St. Paul, MN 55144				
DO NOT SCALE DRAWING	SCALE 4/1	TOLERANCES EXCEPT AS NOTED INCHES .00 ± .01 .000 ± .005 .0000 ±				
THIRD ANGLE PROJECTION	INTERPRET PER ASME Y14.5 - 2009	MILLIMETERS 0 ± .3 .00 ± .13 .000 ±				
MAX SURFACE ROUGHNESS	MARKED SURFACES	CAGE NUMBER D78-5100-2244-1 H				
MARKED ONLY	ANGLES	MODEL D2500 SERIES				
		SHEET NUMBER 5 OF 5				

78-5100-2244-1
 DRAWING NUMBER
 H
 REVISION
 11:12 AM UTC-05:00
 8/5/2016
 H.1

Looking for pricing, stock, or lifecycle information?

Click below to explore more details on WIN SOURCE:

 [View D2514-6002-AR on WIN SOURCE](#)

 [3M Information](#)

Optimize Your Supply Chain with WIN SOURCE Solutions

-  Global Sourcing Solution
-  Obsolete Management
-  Cost Control Management
-  Shortage Management
-  Alternative Solution
-  Excess Inventory Management