



**THE DATASHEET OF  
SAF-XC858CA-13FFI AC**



**8-Bit**

**XC858CA**

8-Bit Single-Chip Microcontroller

**Data Sheet**

V1.0 2010-03

**Microcontrollers**

**Edition 2010-03**

**Published by  
Infineon Technologies AG  
81726 Munich, Germany**

**© 2010 Infineon Technologies AG  
All Rights Reserved.**

#### **Legal Disclaimer**

The information given in this document shall in no event be regarded as a guarantee of conditions or characteristics. With respect to any examples or hints given herein, any typical values stated herein and/or any information regarding the application of the device, Infineon Technologies hereby disclaims any and all warranties and liabilities of any kind, including without limitation, warranties of non-infringement of intellectual property rights of any third party.

#### **Information**

For further information on technology, delivery terms and conditions and prices, please contact the nearest Infineon Technologies Office ([www.infineon.com](http://www.infineon.com)).

#### **Warnings**

Due to technical requirements, components may contain dangerous substances. For information on the types in question, please contact the nearest Infineon Technologies Office.

Infineon Technologies components may be used in life-support devices or systems only with the express written approval of Infineon Technologies, if a failure of such components can reasonably be expected to cause the failure of that life-support device or system or to affect the safety or effectiveness of that device or system. Life support devices or systems are intended to be implanted in the human body or to support and/or maintain and sustain and/or protect human life. If they fail, it is reasonable to assume that the health of the user or other persons may be endangered.

# 8-Bit

# XC858CA

## 8-Bit Single-Chip Microcontroller

### Data Sheet

V1.0 2010-03

**Microcontrollers**

---

## XC858 Data Sheet

### Revision History:

Page	Subjects (major changes since last revision)

### Trademarks

TriCore™ is a trademark of Infineon Technologies AG.

#### **We Listen to Your Comments**

Any information within this document that you feel is wrong, unclear or missing at all?  
Your feedback will help us to continuously improve the quality of this document.

Please send your proposal (including a reference to this document) to:

[mcdocu.comments@infineon.com](mailto:mcdocu.comments@infineon.com)



## Table of Contents

<b>1</b>	<b>Summary of Features</b> .....	<b>1</b>
<b>2</b>	<b>General Device Information</b> .....	<b>4</b>
2.1	Block Diagram .....	4
2.2	Logic Symbol .....	5
2.3	Pin Configuration .....	6
2.4	Pin Definitions and Functions .....	7
<b>3</b>	<b>Functional Description</b> .....	<b>16</b>
3.1	Processor Architecture .....	16
3.2	Memory Organization .....	17
3.2.1	Memory Protection Strategy .....	20
3.2.1.1	Flash Memory Protection .....	20
3.2.2	Special Function Register .....	22
3.2.2.1	Address Extension by Mapping .....	22
3.2.2.2	Address Extension by Paging .....	24
3.2.3	Bit Protection Scheme .....	28
3.2.3.1	Password Register .....	29
3.2.4	XC858 Register Overview .....	30
3.2.4.1	CPU Registers .....	30
3.2.4.2	System Control Registers .....	31
3.2.4.3	WDT Registers .....	34
3.2.4.4	Port Registers .....	34
3.2.4.5	ADC Registers .....	37
3.2.4.6	Timer 2 Compare/Capture Unit Registers .....	41
3.2.4.7	Timer 21 Registers .....	43
3.2.4.8	UART1 Registers .....	43
3.2.4.9	SSC Registers .....	44
3.2.4.10	MultiCAN Registers .....	45
3.2.4.11	OCDS Registers .....	45
3.2.4.12	Flash Registers .....	47
3.3	Flash Memory .....	48
3.3.1	Flash Bank Pagination .....	50
3.4	Interrupt System .....	51
3.4.1	Interrupt Source .....	51
3.4.2	Interrupt Source and Vector .....	57
3.4.3	Interrupt Priority .....	59
3.5	Parallel Ports .....	60
3.6	Power Supply System with Embedded Voltage Regulator .....	62
3.7	Reset Control .....	63
3.7.1	Module Reset Behavior .....	63
3.7.2	Bootling Scheme .....	64

**Table of Contents**

3.8	Clock Generation Unit .....	65
3.8.1	Recommended External Oscillator Circuits .....	67
3.8.2	Clock Management .....	69
3.9	Power Saving Modes .....	71
3.10	Watchdog Timer .....	72
3.11	UART and UART1 .....	74
3.11.1	Baud-Rate Generator .....	75
3.11.2	Baud Rate Generation using Timer 1 .....	78
3.12	Normal Divider Mode (8-bit Auto-reload Timer) .....	78
3.13	High-Speed Synchronous Serial Interface .....	79
3.14	Timer 0 and Timer 1 .....	81
3.15	Timer 2 and Timer 21 .....	82
3.16	Timer 2 Capture/Compare Unit .....	83
3.17	Controller Area Network (MultiCAN) .....	84
3.18	Analog-to-Digital Converter .....	86
3.18.1	ADC Clocking Scheme .....	86
3.18.2	ADC Conversion Sequence .....	87
3.19	On-Chip Debug Support .....	89
3.19.1	JTAG ID Register .....	90
3.20	Chip Identification Number .....	91
<b>4</b>	<b>Electrical Parameters</b> .....	<b>92</b>
4.1	General Parameters .....	92
4.1.1	Parameter Interpretation .....	92
4.1.2	Absolute Maximum Rating .....	93
4.1.3	Operating Conditions .....	94
4.2	DC Parameters .....	95
4.2.1	Input/Output Characteristics .....	95
4.2.2	Supply Threshold Characteristics .....	97
4.2.3	ADC Characteristics .....	98
4.2.3.1	ADC Conversion Timing .....	101
4.2.4	Power Supply Current .....	102
4.3	AC Parameters .....	104
4.3.1	Testing Waveforms .....	104
4.3.2	Output Rise/Fall Times .....	105
4.3.3	Power-on Reset and PLL Timing .....	106
4.3.4	On-Chip Oscillator Characteristics .....	107
4.3.5	External Data Memory Characteristics .....	108
4.3.6	External Clock Drive XTAL1 .....	110
4.3.7	JTAG Timing .....	111
4.3.8	SSC Master Mode Timing .....	113
<b>5</b>	<b>Package and Quality Declaration</b> .....	<b>114</b>
5.1	Package Parameters .....	114

---

**Table of Contents**

5.2	Package Outline .....	115
5.3	Quality Declaration .....	116

# 1 Summary of Features

The XC858 has the following features:

- High-performance XC800 Core
  - compatible with standard 8051 processor
  - two clocks per machine cycle architecture (for memory access without wait state)
  - two data pointers
- On-chip memory
  - 8 Kbytes of Boot ROM
  - 256 bytes of RAM
  - 3 Kbytes of XRAM
  - 64/52/36 Kbytes of Flash; (includes memory protection strategy)
- I/O port supply at 5.0 V and core logic supply at 2.5 V (generated by embedded voltage regulator)

(more features on next page)

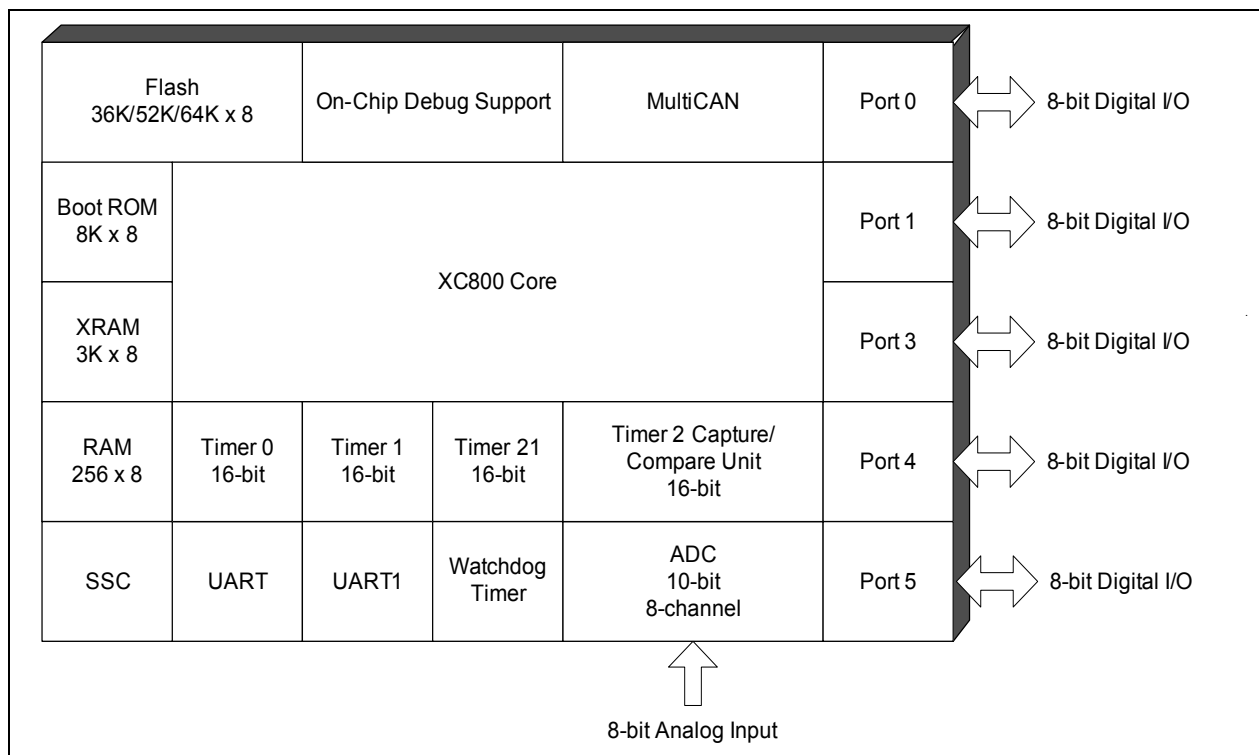

**Figure 1 XC858 Functional Units**

---

**Summary of Features**

Features: (continued)

- Power-on reset generation
- Brownout detection for core logic supply
- On-chip OSC and PLL for clock generation
  - Loss-of-Clock detection
- Power saving modes
  - slow-down mode
  - idle mode
  - power-down mode with wake-up capability via RXD or EXINT0
  - clock gating control to each peripheral
- Programmable 16-bit Watchdog Timer (WDT)
- Five ports
  - Up to 40 pins as digital I/O
  - 8 dedicated analog inputs used as A/D converter input
- 8-channel, 10-bit ADC
- Four 16-bit timers
  - Timer 0 and Timer 1 (T0 and T1)
  - Timer 2 and Timer 21 (T2 and T21)
- MultiCAN with 2 nodes, 32 message objects
- Timer 2 Capture/compare unit for PWM signal generation (T2CCU)
- Two full-duplex serial interfaces (UART and UART1)
- Synchronous serial channel (SSC)
- On-chip debug support
  - 1 Kbyte of monitor ROM (part of the 8-Kbyte Boot ROM)
  - 64 bytes of monitor RAM
- PG-LQFP-64 pin package
- Temperature range  $T_A$ :
  - SAF (-40 to 85 °C)

---

**Summary of Features**
**XC858 Variant Devices**

The XC858 product family features devices with different program memory sizes.

The list of XC858 devices and their difference are summarized in **Table 1**. The type of package available is the LQFP-64.

**Table 1 Device Summary**

<b>Sales Type</b>	<b>Device Type</b>	<b>Program Memory (Kbytes)</b>	<b>Power Supply (V)</b>	<b>Temperature (°C)</b>	<b>Quality Profile</b>
SAF-XC858CA-9FFI 5V	Flash	36	5.0	-40 to 85	Industrial
SAF-XC858CA-13FFI 5V	Flash	52	5.0	-40 to 85	Industrial
SAF-XC858CA-16FFI 5V	Flash	64	5.0	-40 to 85	Industrial

As this document refers to all the derivatives, some description may not apply to a specific product. For simplicity, all versions are referred to by the term XC858 throughout this document.

**Ordering Information**

The ordering code for Infineon Technologies microcontrollers provides an exact reference to the required product. This ordering code identifies:

- The derivative itself, i.e. its function set, the temperature range, and the supply voltage
- The package and the type of delivery

For the available ordering codes for the XC858, please refer to your responsible sales representative or your local distributor.

## 2 General Device Information

Chapter 2 contains the block diagram, pin configurations, definitions and functions of the XC858.

### 2.1 Block Diagram

The block diagram of the XC858 is shown in Figure 2.

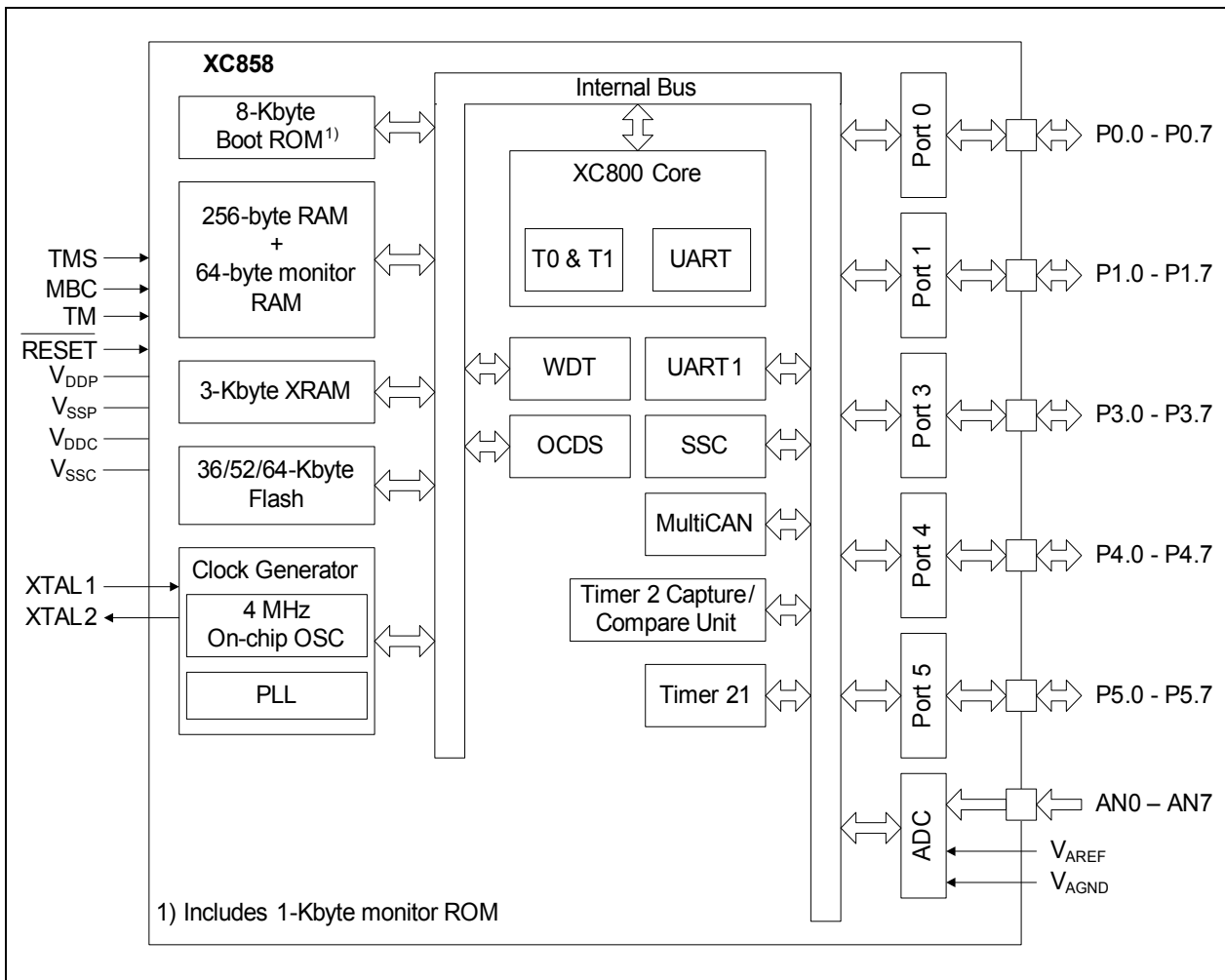

Figure 2 XC858 Block Diagram

## 2.2 Logic Symbol

The logic symbol of the XC858 is shown in [Figure 3](#).

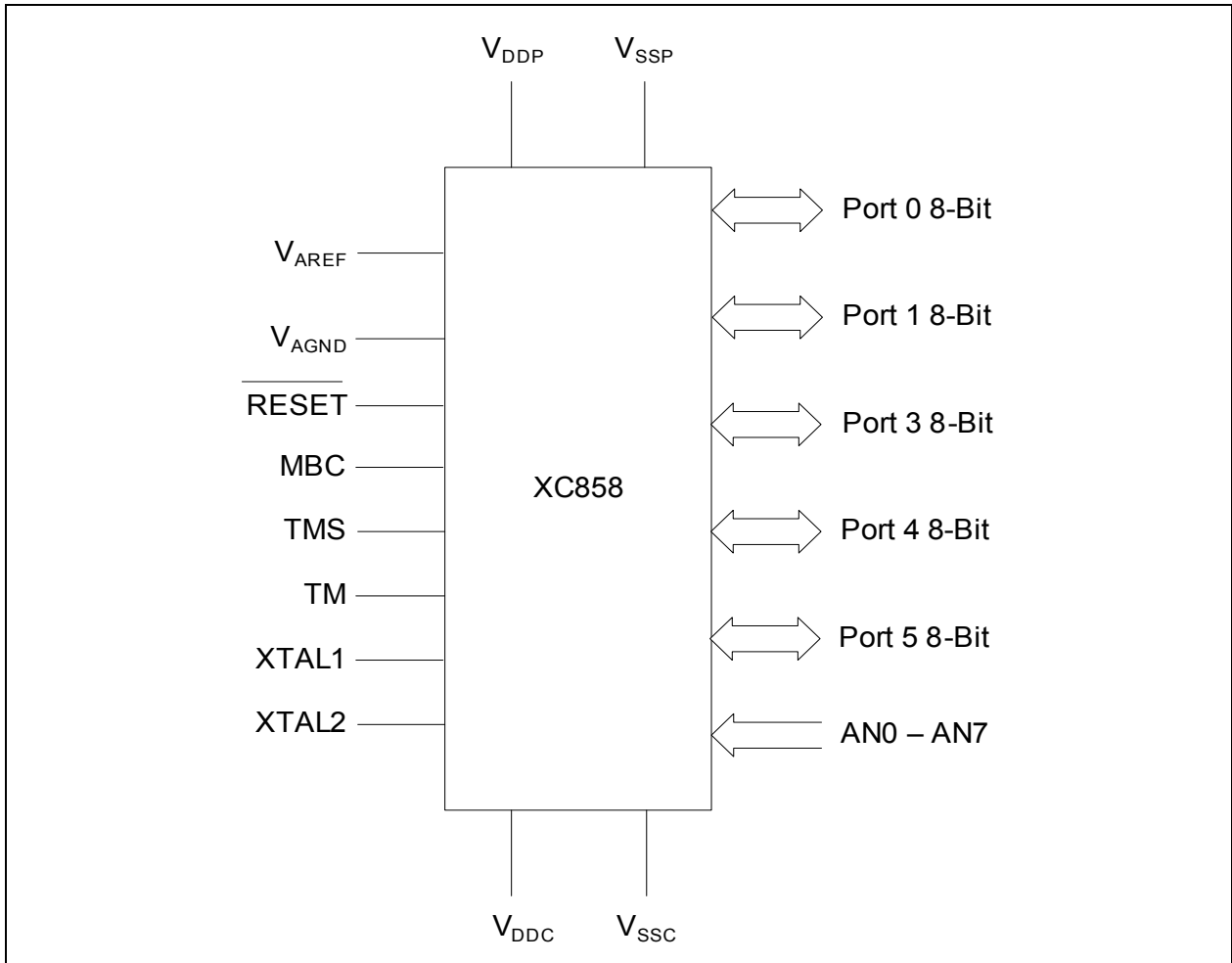

Figure 3 XC858 Logic Symbol

### 2.3 Pin Configuration

The pin configuration of the XC858 in [Figure 4](#).

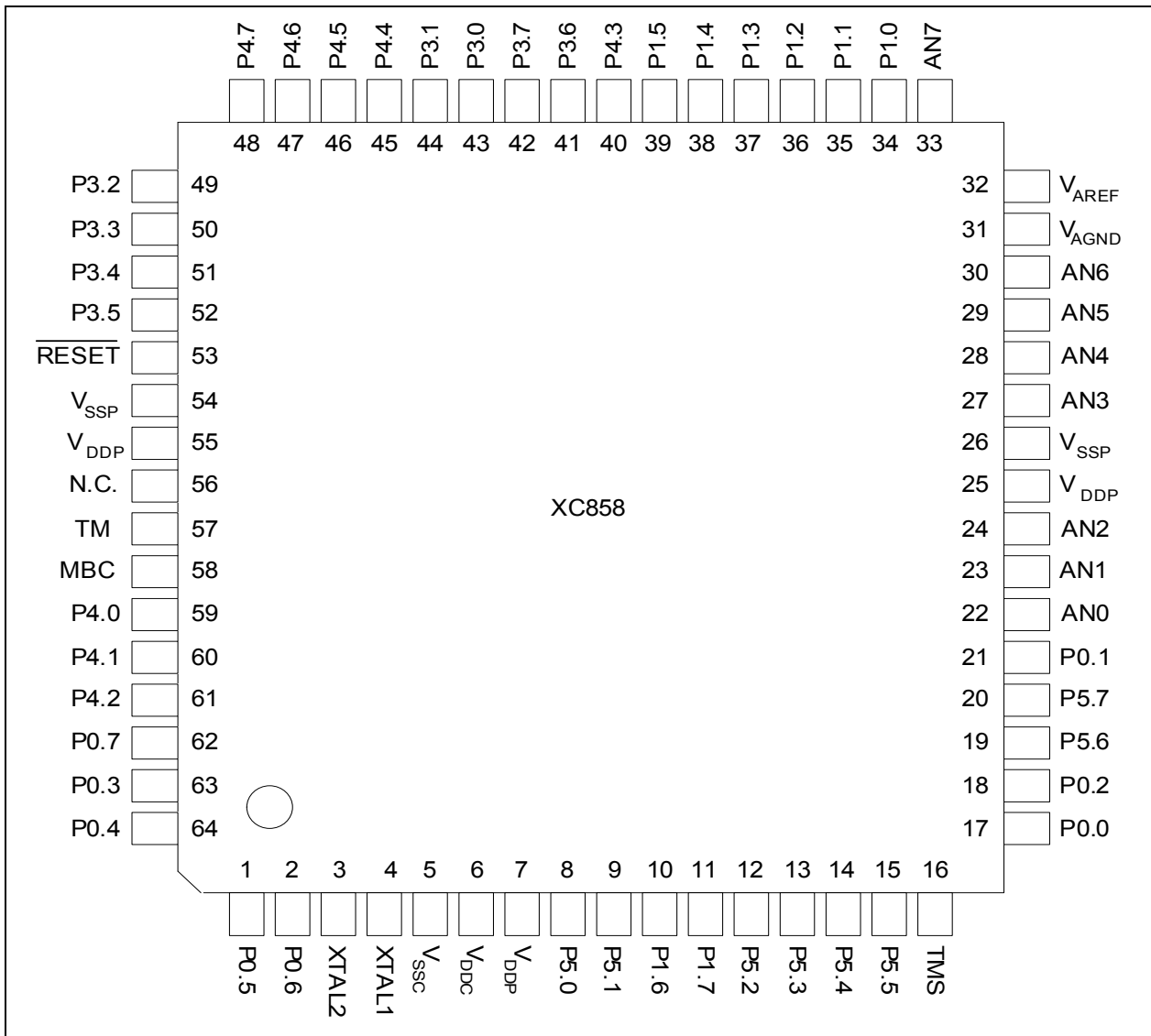

Figure 4 XC858 Pin Configuration, PG-LQFP-64 Package (top view)

## 2.4 Pin Definitions and Functions

The functions and default states of the XC858 external pins are provided in [Table 2](#).

**Table 2 Pin Definitions and Functions**

Symbol	Pin Number (LQFP-64)	Type	Reset State	Function
<b>P0</b>		I/O		<b>Port 0</b> Port 0 is an 8-bit bidirectional general purpose I/O port. It can be used as alternate functions for the JTAG, UART, UART1, T2CCU, Timer 21, MultiCAN, SSC and External Interface.
P0.0	17		Hi-Z	TCK_0 JTAG Clock Input CLKOUT_0 Clock Output RXDO_1 UART Transmit Data Output
P0.1	21		Hi-Z	TDI_0 JTAG Serial Data Input RXD_1 UART Receive Data Input RXDC1_0 MultiCAN Node 1 Receiver Input EXF2_1 Timer 2 External Flag Output
P0.2	18		PU	TDO_0 JTAG Serial Data Output TXD_1 UART Transmit Data Output/Clock Output TXDC1_0 MultiCAN Node 1 Transmitter Output
P0.3	63		Hi-Z	SCK_1 SSC Clock Input/Output RXDO1_0 UART1 Transmit Data Output A17 Address Line 17 Output
P0.4	64		Hi-Z	MTSR_1 SSC Master Transmit Output/ Slave Receive Input TXD1_0 UART1 Transmit Data Output/Clock Output A18 Address Line 18 Output
P0.5	1		Hi-Z	MRST_1 SSC Master Receive Input/Slave Transmit Output EXINT0_0 External Interrupt Input 0 T2EX1_1 Timer 21 External Trigger Input RXD1_0 UART1 Receive Data Input A19 Address Line 19 Output

General Device Information

**Table 2 Pin Definitions and Functions (cont'd)**

Symbol	Pin Number (LQFP-64)	Type	Reset State	Function
P0.6	2		PU	$\overline{T2CC4\_1}$ Compare Output Channel 4 $\overline{WR}$ External Data Write Control Output
P0.7	62		PU	$\overline{CLKOUT\_1}$ Clock Output $\overline{T2CC5\_1}$ Compare Output Channel 5 $\overline{RD}$ External Data Read Control Output

**General Device Information**
**Table 2 Pin Definitions and Functions (cont'd)**

Symbol	Pin Number (LQFP-64)	Type	Reset State	Function
<b>P1</b>		I/O		<b>Port 1</b> Port 1 is an 8-bit bidirectional general purpose I/O port. It can be used as alternate functions for the JTAG, UART, Timer 0, Timer 1, T2CCU, Timer 21, MultiCAN, SSC and External Interface.
P1.0	34		PU	RXD_0      UART Receive Data Input T2EX_0      Timer 2 External Trigger Input RXDC0_0    MultiCAN Node 0 Receiver Input A8           Address Line 8 Output
P1.1	35		PU	EXINT3_0   External Interrupt Input 3 T0_1        Timer 0 Input TXD_0       UART Transmit Data Output/Clock Output TXDC0_0    MultiCAN Node 0 Transmitter Output A9           Address Line 9 Output
P1.2	36		PU	SCK_0       SSC Clock Input/Output A10          Address Line 10 Output
P1.3	37		PU	MTSR_0     SSC Master Transmit Output/Slave Receive Input SCK_2       SSC Clock Input/Output TXDC1_3     MultiCAN Node 1 Transmitter Output A11          Address Line 11 Output
P1.4	38		PU	MRST_0     SSC Master Receive Input/ Slave Transmit Output EXINT0_1    External Interrupt Input 0 RXDC1_3     MultiCAN Node 1 Receiver Input MTSR_2      SSC Master Transmit Output/Slave Receive Input A12          Address Line 12 Output

**General Device Information**
**Table 2 Pin Definitions and Functions (cont'd)**

Symbol	Pin Number (LQFP-64)	Type	Reset State	Function
P1.5	39		PU	EXINT5_0 External Interrupt Input 5 T1_1 Timer 1 Input MRST_2 SSC Master Receive Input/ Slave Transmit Output EXF2_0 Timer 2 External Flag Output RXDO_0 UART Transmit Data Output
P1.6	10		PU	EXINT6_0 External Interrupt Input 6 RXDC0_2 MultiCAN Node 0 Receiver Input T21_1 Timer 21 Input
P1.7	11		PU	T2_1 Timer 2 Input TXDC0_2 MultiCAN Node 0 Transmitter Output  P1.5 and P1.6 can be used as a software chip select output for the SSC.

**General Device Information**
**Table 2 Pin Definitions and Functions (cont'd)**

Symbol	Pin Number (LQFP-64)	Type	Reset State	Function
<b>P3</b>		I/O		<b>Port 3</b> Port 3 is an 8-bit bidirectional general purpose I/O port. It can be used as alternate functions for UART1, T2CCU, Timer 21, MultiCAN and External Interface.
P3.0	43		Hi-Z	RXDO1_1    UART1 Transmit Data Output T2CC0_1/    External Interrupt Input 3/T2CCU EXINT3_2    Capture/Compare Channel 0
P3.1	44		Hi-Z	TXD1_1    UART1 Transmit Data Output/Clock Output
P3.2	49		Hi-Z	RXDC1_1    MultiCAN Node 1 Receiver Input RXD1_1    UART1 Receive Data Input T2CC1_1/    External Interrupt Input 4/T2CCU EXINT4_2    Capture/Compare Channel 1
P3.3	50		Hi-Z	TXDC1_1    MultiCAN Node 1 Transmitter Output T2CC2_1/    External Interrupt Input 5/T2CCU EXINT5_2    Capture/Compare Channel 2 A13    Address Line 13 Output
P3.4	51		Hi-Z	RXDC0_1    MultiCAN Node 0 Receiver Input T2EX1_0    Timer 21 External Trigger Input T2CC3_1/    External Interrupt Input 6/T2CCU EXINT6_3    Capture/Compare Channel 3 A14    Address Line 14 Output
P3.5	52		Hi-Z	EXF21_0    Timer 21 External Flag Output TXDC0_1    MultiCAN Node 0 Transmitter Output A15    Address Line 15 Output
P3.6	41		PU	-
P3.7	42		Hi-Z	EXINT4_0    External Interrupt Input 4 A16    Address Line 16 Output

**General Device Information**
**Table 2 Pin Definitions and Functions (cont'd)**

Symbol	Pin Number (LQFP-64)	Type	Reset State	Function
<b>P4</b>		I/O		<b>Port 4</b> Port 4 is an 8-bit bidirectional general purpose I/O port. It can be used as alternate functions for Timer 0, Timer 1, T2CCU, Timer 21, MultiCAN and External Interface.
P4.0	59		Hi-Z	RXDC0_3 MultiCAN Node 0 Receiver Input T2CC0_0/ External Interrupt Input 3/T2CCU EXINT3_1 Capture/Compare Channel 0 D0 Data Line 0 Input/Output
P4.1	60		Hi-Z	TXDC0_3 MultiCAN Node 0 Transmitter Output T2CC1_0/ External Interrupt Input 4/T2CCU EXINT4_1 Capture/Compare Channel 1 D1 Data Line 1 Input/Output
P4.2	61		PU	EXINT6_1 External Interrupt Input 6 T21_0 Timer 21 Input D2 Data Line 2 Input/Output
P4.3	40		Hi-Z	T2EX_1 Timer 2 External Trigger Input EXF21_1 Timer 21 External Flag Output D3 Data Line 3 Input/Output
P4.4	45		Hi-Z	T0_0 Timer 0 Input T2CC2_0/ External Interrupt Input 5/T2CCU EXINT5_1 Capture/Compare Channel 2 D4 Data Line 4 Input/Output
P4.5	46		Hi-Z	T1_0 Timer 1 Input T2CC3_0/ External Interrupt Input 6/T2CCU EXINT6_2 Capture/Compare Channel 3 D5 Data Line 5 Input/Output
P4.6	47		Hi-Z	T2_0 Timer 2 Input T2CC4_0 Compare Output Channel 4 D6 Data Line 6 Input/Output
P4.7	48		Hi-Z	T2CC5_0 Compare Output Channel 5 D7 Data Line 7 Input/Output

**General Device Information**
**Table 2 Pin Definitions and Functions (cont'd)**

Symbol	Pin Number (LQFP-64)	Type	Reset State	Function
<b>P5</b>		I/O		<b>Port 5</b> Port 5 is an 8-bit bidirectional general purpose I/O port. It can be used as alternate functions for UART, UART1, T2CCU, JTAG and External Interface.
P5.0	8		PU	EXINT1_1 External Interrupt Input 1 A0 Address Line 0 Output
P5.1	9		PU	EXINT2_1 External Interrupt Input 2 A1 Address Line 1 Output
P5.2	12		PU	RXD_2 UART Receive Data Input T2CC2_2/ External Interrupt Input 5/T2CCU EXINT5_3 Capture/Compare Channel 2 A2 Address Line 2 Output
P5.3	13		PU	EXINT1_0 External Interrupt Input 1 TXD_2 UART Transmit Data Output/Clock Output T2CC5_2 Compare Output Channel 5 A3 Address Line 3 Output
P5.4	14		PU	EXINT2_0 External Interrupt Input 2 RXDO_2 UART Transmit Data Output T2CC4_2 Compare Output Channel 4 A4 Address Line 4 Output
P5.5	15		PU	TDO_1 JTAG Serial Data Output TXD1_2 UART1 Transmit Data Output/ Clock Output T2CC0_2/ External Interrupt Input 3/T2CCU EXINT3_3 Capture/Compare Channel 0 A5 Address Line 5 Output
P5.6	19		PU	TCK_1 JTAG Clock Input RXDO1_2 UART1 Transmit Data Output T2CC1_2/ External Interrupt Input 4/T2CCU EXINT4_3 Capture/Compare Channel 1 A6 Address Line 6 Output

General Device Information

**Table 2 Pin Definitions and Functions (cont'd)**

Symbol	Pin Number (LQFP-64)	Type	Reset State	Function
P5.7	20		PU	TDI_1 JTAG Serial Data Input RXD1_2 UART1 Receive Data Input T2CC3_2/ External Interrupt Input 6/T2CCU EXINT6_4 Capture/Compare Channel 3 A7 Address Line 7 Output

**General Device Information**
**Table 2 Pin Definitions and Functions (cont'd)**

<b>Symbol</b>	<b>Pin Number (LQFP-64)</b>	<b>Type</b>	<b>Reset State</b>	<b>Function</b>
$V_{DDP}$	7, 25, 55	–	–	<b>I/O Port Supply ( 5.0 V)</b> Also used by EVR and analog modules. All pins must be connected.
$V_{SSP}$	26, 54	–	–	<b>I/O Ground</b> All pins must be connected.
$V_{DDC}$	6	–	–	<b>Core Supply Monitor (2.5 V)</b>
$V_{SSC}$	5	–	–	<b>Core Supply Ground</b>
$V_{AREF}$	32	–	–	<b>ADC Reference Voltage</b>
$V_{AGND}$	31	–	–	<b>ADC Reference Ground</b>
<b>AN0</b>	22	I	Hi-Z	<b>Analog Input 0</b>
<b>AN1</b>	23	I	Hi-Z	<b>Analog Input 1</b>
<b>AN2</b>	24	I	Hi-Z	<b>Analog Input 2</b>
<b>AN3</b>	27	I	Hi-Z	<b>Analog Input 3</b>
<b>AN4</b>	28	I	Hi-Z	<b>Analog Input 4</b>
<b>AN5</b>	29	I	Hi-Z	<b>Analog Input 5</b>
<b>AN6</b>	30	I	Hi-Z	<b>Analog Input 6</b>
<b>AN7</b>	33	I	Hi-Z	<b>Analog Input 7</b>
<b>XTAL1</b>	4	I	Hi-Z	<b>External Oscillator Input</b> <b>(Feedback resistor required, normally NC)</b>
<b>XTAL2</b>	3	O	Hi-Z	<b>External Oscillator Output</b> <b>(Feedback resistor required, normally NC)</b>
<b>TMS</b>	16	I	PD	<b>JTAG Test Mode Select</b>
<b>RESET</b>	53	I	PU	<b>Reset Input</b>
<b>MBC</b>	58	I	PU	<b>Monitor &amp; BootStrap Loader Control</b>
<b>TM</b>	57	–	–	<b>Test Mode</b> <b>(External pull down device required)</b>
<b>NC</b>	56	–	–	<b>No Connection</b>

### 3 Functional Description

Chapter 3 provides an overview of the XC858 functional description.

#### 3.1 Processor Architecture

The XC858 is based on a high-performance 8-bit Central Processing Unit (CPU) that is compatible with the standard 8051 processor. While the standard 8051 processor is designed around a 12-clock machine cycle, the XC858 CPU uses a 2-clock machine cycle. This allows fast access to ROM or RAM memories without wait state. The instruction set consists of 45% one-byte, 41% two-byte and 14% three-byte instructions. The XC858 CPU provides a range of debugging features, including basic stop/start, single-step execution, breakpoint support and read/write access to the data memory, program memory and Special Function Registers (SFRs).

Figure 5 shows the CPU functional blocks.

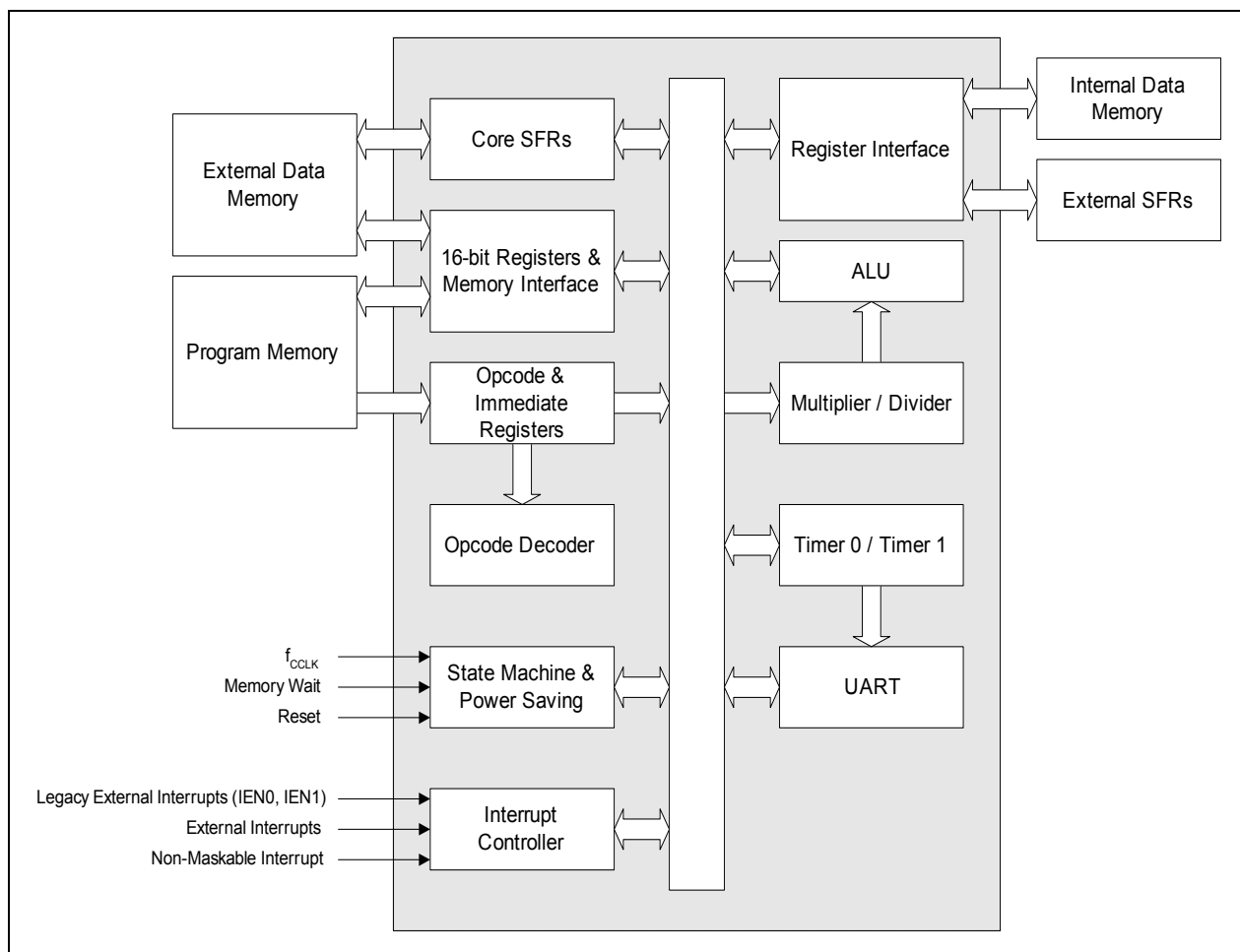

Figure 5 CPU Block Diagram

Functional Description

3.2 Memory Organization

The XC858 CPU operates in the following address spaces:

- 8 Kbytes of Boot ROM program memory
- 256 bytes of internal RAM data memory
- 3 Kbytes of XRAM memory  
(XRAM can be read/written as program memory or external data memory)
- A 128-byte Special Function Register area
- 64/52/36 Kbytes of Flash program memory (Flash devices)

Figure 6, Figure 7 and Figure 8 illustrates the memory address spaces of the XC858 with 64Kbytes, 52Kbytes and 36Kbytes embedded Flash respectively.

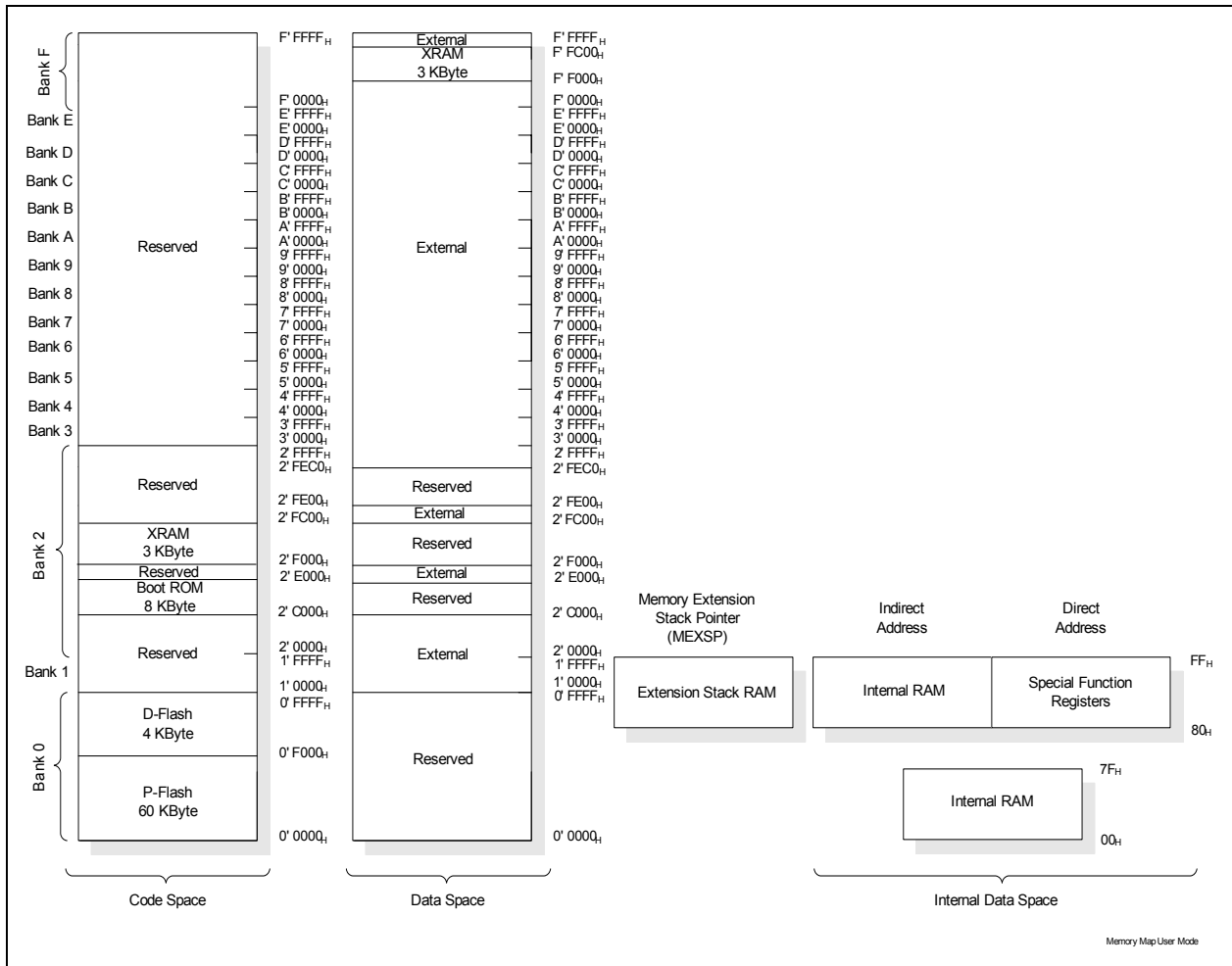

Figure 6 Memory Map of XC858 with 64K Flash Memory in user mode

Functional Description

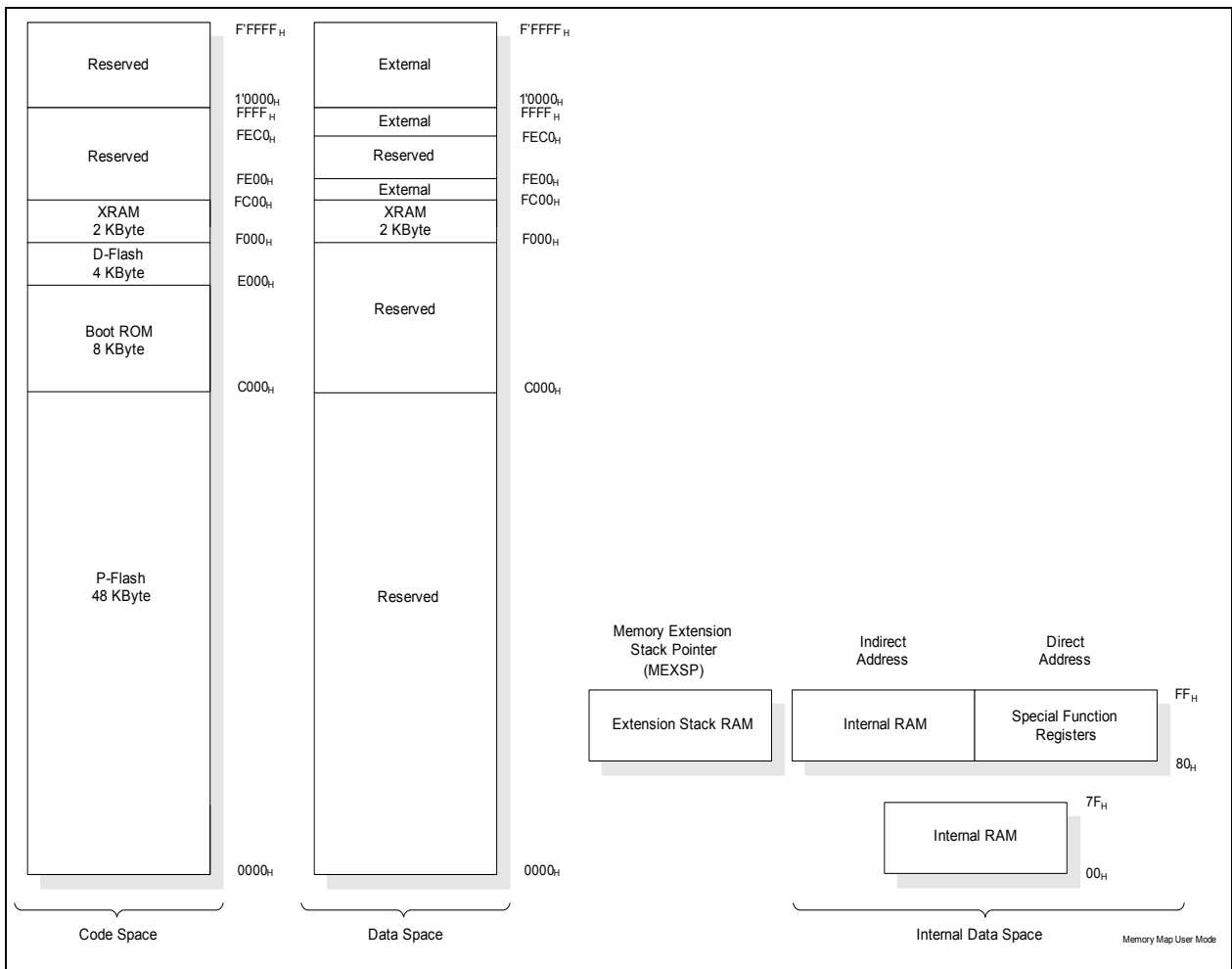

Figure 7 Memory Map of XC858 with 52K Flash Memory in user mode

Functional Description

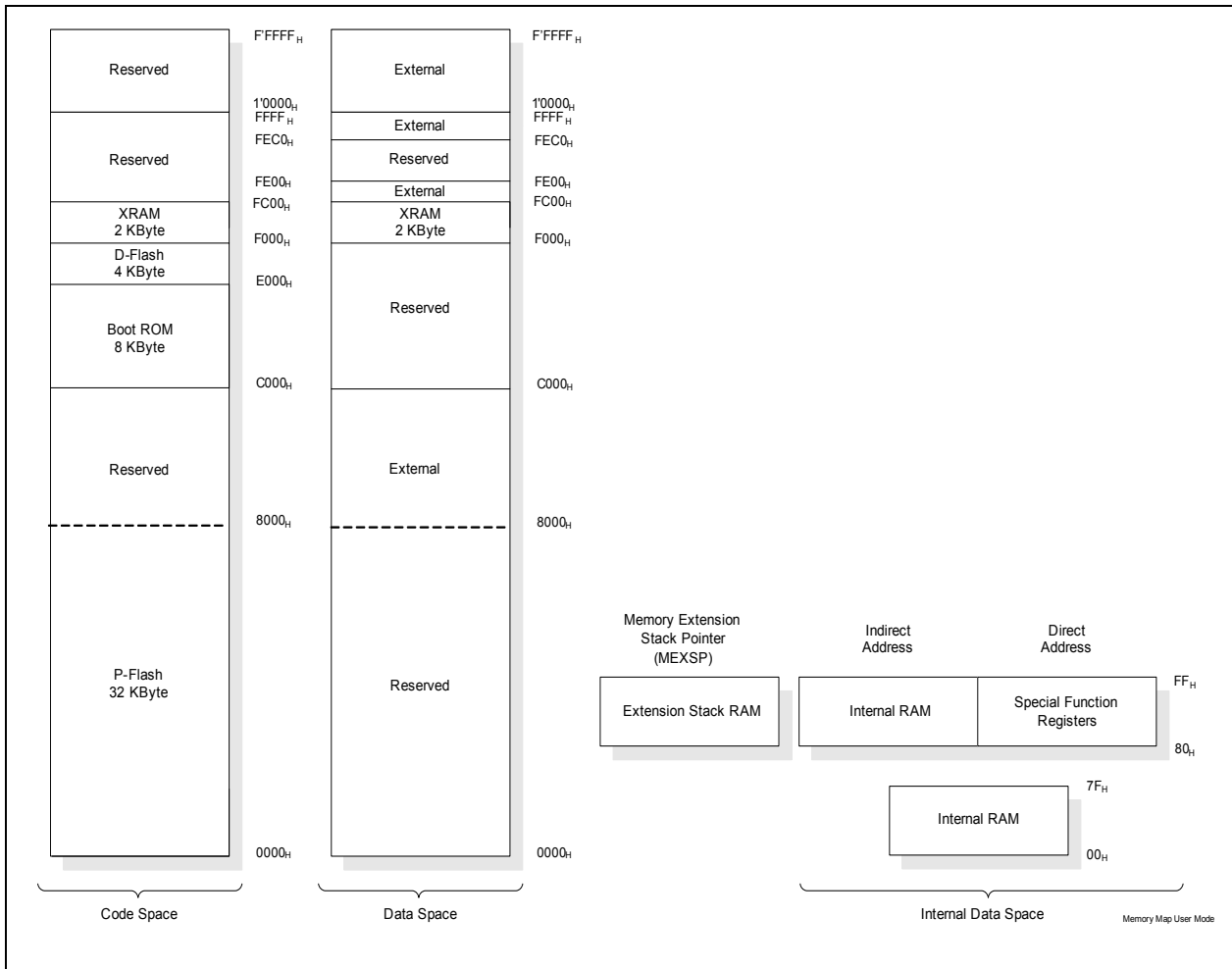

Figure 8 Memory Map of XC858 with 36K Flash Memory in user mode

### 3.2.1 Memory Protection Strategy

The XC858 memory protection strategy includes:

- Basic protection: The user is able to block any external access via the boot option to any memory
- Read-out protection: The user is able to protect the contents in the Flash
- Flash program and erase protection

These protection strategies are enabled by programming a valid password (16-bit non-one value) via Bootstrap Loader (BSL) mode 6.

#### 3.2.1.1 Flash Memory Protection

As long as a valid password is available, all external access to the device, including the Flash, will be blocked.

For additional security, the Flash hardware protection can be enabled to implement a second layer of read-out protection, as well as to enable program and erase protection.

Flash hardware protection is available only for Flash devices and comes in two modes:

- Mode 0: Only the P-Flash is protected; the D-Flash is unprotected
- Mode 1: Both the P-Flash and D-Flash are protected

The selection of each protection mode and the restrictions imposed are summarized in [Table 3](#).

**Table 3 Flash Protection Modes**

Flash Protection	Without hardware protection	With hardware protection	
Hardware Protection Mode	-	0	1
Activation	Program a valid password via BSL mode 6		
Selection	Bit 13 of password = 0	Bit 13 of password = 1 MSB of password = 0	Bit 13 of password = 1 MSB of password = 1
P-Flash contents can be read by	Read instructions in any program memory	Read instructions in the P-Flash	Read instructions in the P-Flash or D-Flash
External access to P-Flash	Not possible	Not possible	Not possible

**Functional Description**
**Table 3 Flash Protection Modes (cont'd)**

Flash Protection	Without hardware protection		With hardware protection	
<b>P-Flash program and erase</b>	Possible		Possible only on the condition that MSB - 1 of password is set to 1	Possible only on the condition that MSB - 1 of password is set to 1
<b>D-Flash contents can be read by</b>	Read instructions in any program memory		Read instructions in any program memory	Read instructions in the P-Flash or D-Flash
<b>External access to D-Flash</b>	Not possible		Not possible	Not possible
<b>D-Flash program</b>	Possible		Possible	Possible, on the condition that MSB - 1 of password is set to 1
<b>D-Flash erase</b>	Possible		Possible, on these conditions: <ul style="list-style-type: none"> <li>• MISC_CON.DFLASH EN bit is set to 1 prior to each erase operation; or</li> <li>• the MSB - 1 of password is set to 1</li> </ul>	Possible, on the condition that MSB - 1 of password is set to 1

BSL mode 6, which is used for enabling Flash protection, can also be used for disabling Flash protection. Here, the programmed password must be provided by the user. To disable the flash protection, a password match is required. A password match triggers an automatic erase of the protected P-Flash and D-Flash contents, including the programmed password. With a valid password, the Flash hardware protection is then enabled or disabled upon next reset. For the other protection strategies, no reset is necessary.

Although no protection scheme can be considered infallible, the XC858 memory protection strategy provides a very high level of protection for a general purpose microcontroller.

### 3.2.2 Special Function Register

The Special Function Registers (SFRs) occupy direct internal data memory space in the range  $80_H$  to  $FF_H$ . All registers, except the program counter, reside in the SFR area. The SFRs include pointers and registers that provide an interface between the CPU and the on-chip peripherals. As the 128-SFR range is less than the total number of registers required, address extension mechanisms are required to increase the number of addressable SFRs. The address extension mechanisms include:

- Mapping
- Paging

#### 3.2.2.1 Address Extension by Mapping

Address extension is performed at the system level by mapping. The SFR area is extended into two portions: the standard (non-mapped) SFR area and the mapped SFR area. Each portion supports the same address range  $80_H$  to  $FF_H$ , bringing the number of addressable SFRs to 256. The extended address range is not directly controlled by the CPU instruction itself, but is derived from bit RMAP in the system control register SYSCON0 at address  $8F_H$ . To access SFRs in the mapped area, bit RMAP in SFR SYSCON0 must be set. Alternatively, the SFRs in the standard area can be accessed by clearing bit RMAP. The SFR area can be selected as shown in [Figure 9](#).

As long as bit RMAP is set, the mapped SFR area can be accessed. This bit is not cleared automatically by hardware. Thus, before standard/mapped registers are accessed, bit RMAP must be cleared/set, respectively, by software.

Functional Description

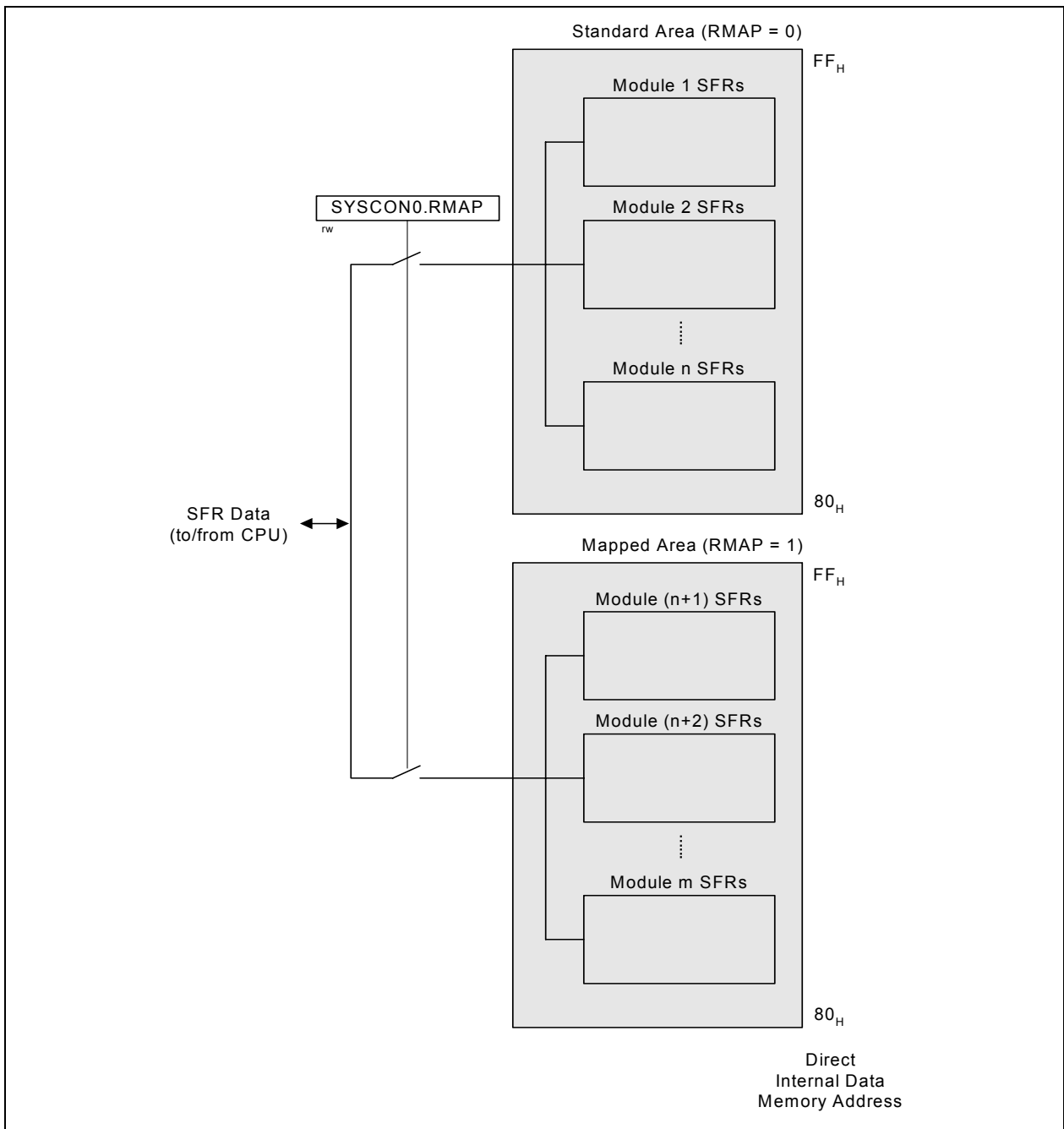

Figure 9 Address Extension by Mapping

Functional Description

**SYSCON0**

**System Control Register 0**

Reset Value: 04<sub>H</sub>

7	6	5	4	3	2	1	0
	0		<b>IMODE</b>	0	1	0	<b>RMAP</b>
	r		rw	r	r	r	rw

Field	Bits	Type	Description
<b>RMAP</b>	0	rw	<b>Interrupt Node XINTR0 Enable</b> 0 The access to the standard SFR area is enabled 1 The access to the mapped SFR area is enabled
<b>1</b>	2	r	<b>Reserved</b> Returns 1 if read; should be written with 1.
<b>0</b>	[7:5], 3,1	r	<b>Reserved</b> Returns 0 if read; should be written with 0.

*Note: The RMAP bit should be cleared/set by ANL or ORL instructions. The rest bits of SYSCON0 should not be modified.*

**3.2.2.2 Address Extension by Paging**

Address extension is further performed at the module level by paging. With the address extension by mapping, the XC858 has a 256-SFR address range. However, this is still less than the total number of SFRs needed by the on-chip peripherals. To meet this requirement, some peripherals have a built-in local address extension mechanism for increasing the number of addressable SFRs. The extended address range is not directly controlled by the CPU instruction itself, but is derived from bit field PAGE in the module page register MOD\_PAGE. Hence, the bit field PAGE must be programmed before accessing the SFR of the target module. Each module may contain a different number of pages and a different number of SFRs per page, depending on the specific requirement. Besides setting the correct RMAP bit value to select the SFR area, the user must also ensure that a valid PAGE is selected to target the desired SFR. A page inside the extended address range can be selected as shown in [Figure 10](#).

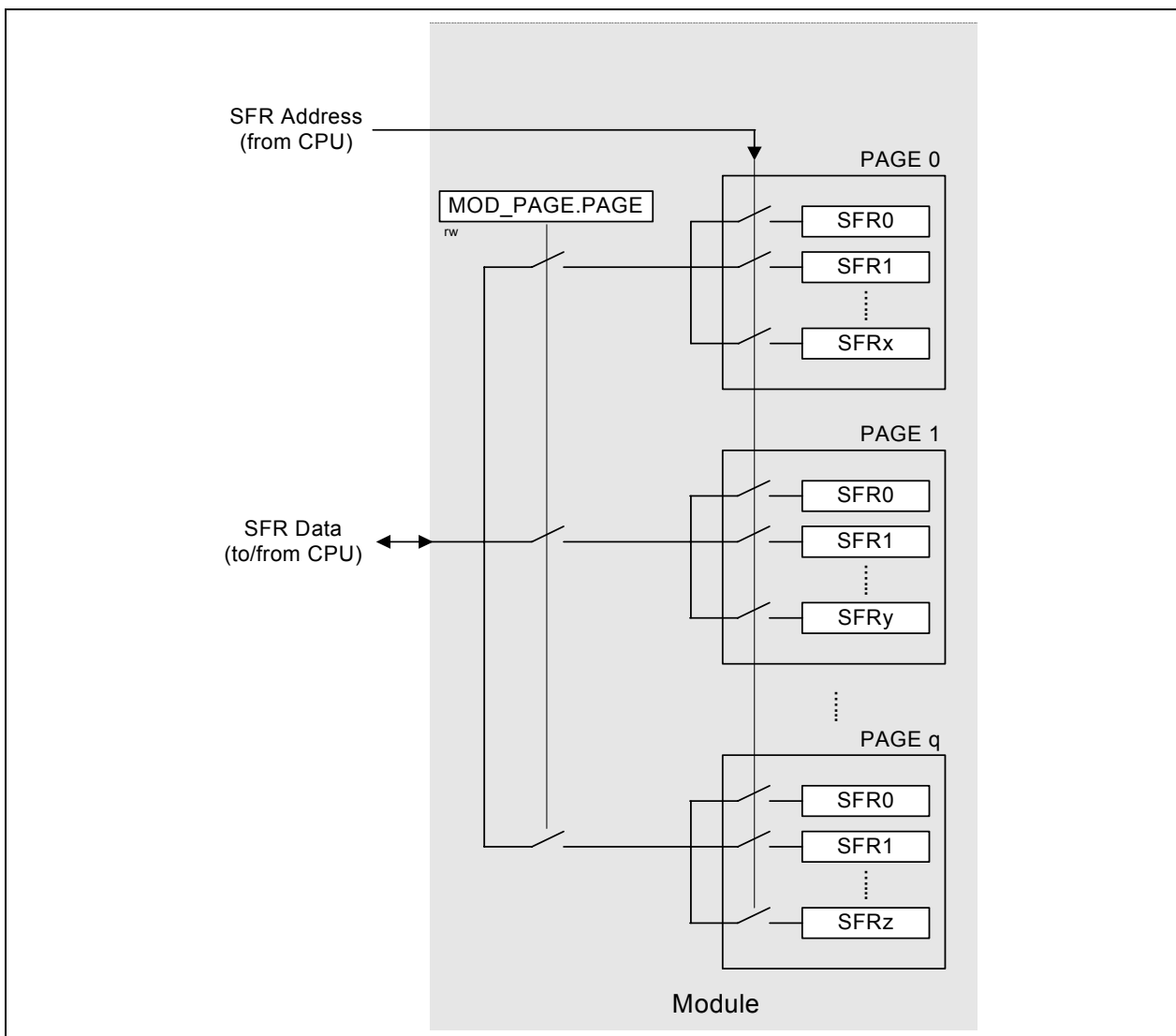

**Figure 10 Address Extension by Paging**

In order to access a register located in a page different from the actual one, the current page must be exited. This is done by reprogramming the bit field PAGE in the page register. Only then can the desired access be performed.

If an interrupt routine is initiated between the page register access and the module register access, and the interrupt needs to access a register located in another page, the current page setting can be saved, the new one programmed and the old page setting restored. This is possible with the storage fields STx (x = 0 - 3) for the save and restore action of the current page setting. By indicating which storage bit field should be used in parallel with the new page value, a single write operation can:

- Save the contents of PAGE in STx before overwriting with the new value (this is done in the beginning of the interrupt routine to save the current page setting and program the new page number); or

**Functional Description**

- Overwrite the contents of PAGE with the contents of STx, ignoring the value written to the bit positions of PAGE  
(this is done at the end of the interrupt routine to restore the previous page setting before the interrupt occurred)

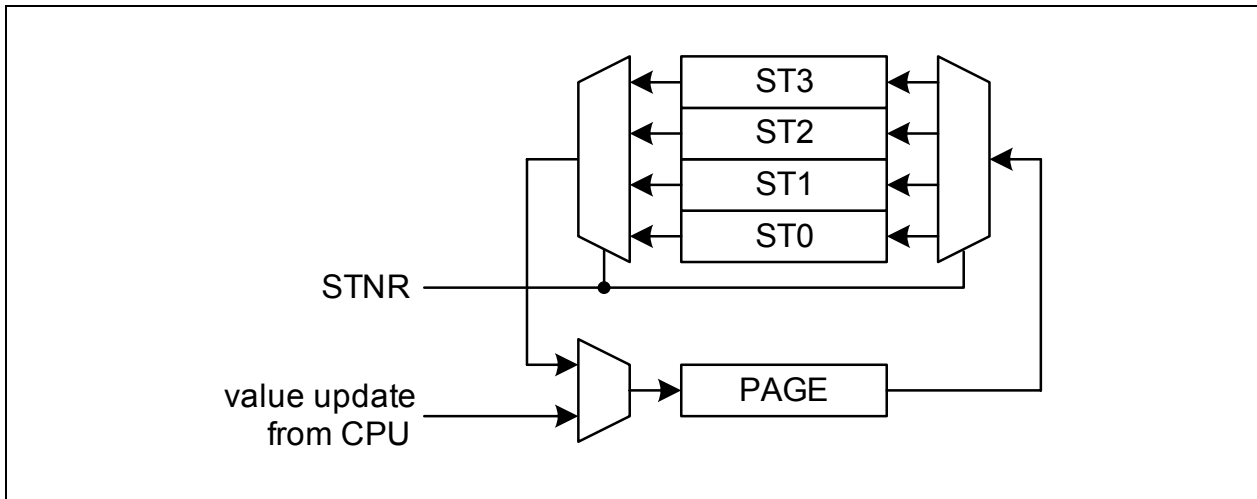

**Figure 11 Storage Elements for Paging**

With this mechanism, a certain number of interrupt routines (or other routines) can perform page changes without reading and storing the previously used page information. The use of only write operations makes the system simpler and faster. Consequently, this mechanism significantly improves the performance of short interrupt routines.

The XC858 supports local address extension for:

- Parallel Ports
- Analog-to-Digital Converter (ADC)
- System Control Registers

Functional Description

The page register has the following definition:

**MOD\_PAGE**

Page Register for module MOD

Reset Value: 00<sub>H</sub>

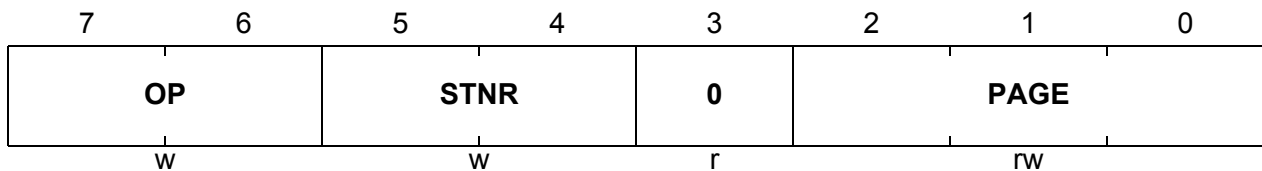

Field	Bits	Type	Description
<b>PAGE</b>	[2:0]	rw	<p><b>Page Bits</b>                      When written, the value indicates the new page.                      When read, the value indicates the currently active page.</p>
<b>STNR</b>	[5:4]	w	<p><b>Storage Number</b>                      This number indicates which storage bit field is the target of the operation defined by bit field OP.                      If OP = 10<sub>B</sub>,                      the contents of PAGE are saved in STx before being overwritten with the new value.                      If OP = 11<sub>B</sub>,                      the contents of PAGE are overwritten by the contents of STx. The value written to the bit positions of PAGE is ignored.</p> <p>00 ST0 is selected.                      01 ST1 is selected.                      10 ST2 is selected.                      11 ST3 is selected.</p>

**Functional Description**

Field	Bits	Type	Description
<b>OP</b>	[7:6]	w	<b>Operation</b> 0X Manual page mode. The value of STNR is ignored and PAGE is directly written. 10 New page programming with automatic page saving. The value written to the bit positions of PAGE is stored. In parallel, the previous contents of PAGE are saved in the storage bit field STx indicated by STNR. 11 Automatic restore page action. The value written to the bit positions PAGE is ignored and instead, PAGE is overwritten by the contents of the storage bit field STx indicated by STNR.
<b>0</b>	3	r	<b>Reserved</b> Returns 0 if read; should be written with 0.

**3.2.3 Bit Protection Scheme**

The bit protection scheme prevents direct software writing of selected bits (i.e., protected bits) using the PASSWD register. When the bit field MODE is 11<sub>B</sub>, writing 10011<sub>B</sub> to the bit field PASS opens access to writing of all protected bits, and writing 10101<sub>B</sub> to the bit field PASS closes access to writing of all protected bits. In both cases, the value of the bit field MODE is not changed even if PASSWD register is written with 98<sub>H</sub> or A8<sub>H</sub>. It can only be changed when bit field PASS is written with 11000<sub>B</sub>, for example, writing D0<sub>H</sub> to PASSWD register disables the bit protection scheme.

Note that access is opened for maximum 32 CCLKs if the “close access” password is not written. If “open access” password is written again before the end of 32 CCLK cycles, there will be a recount of 32 CCLK cycles. The protected bits include the N- and K-Divider bits, NDIV and KDIV; the Watchdog Timer enable bit, WDTEN; and the power-down and slow-down enable bits, PD and SD.

Functional Description

3.2.3.1 Password Register

PASSWD

Password Register

Reset Value: 07<sub>H</sub>

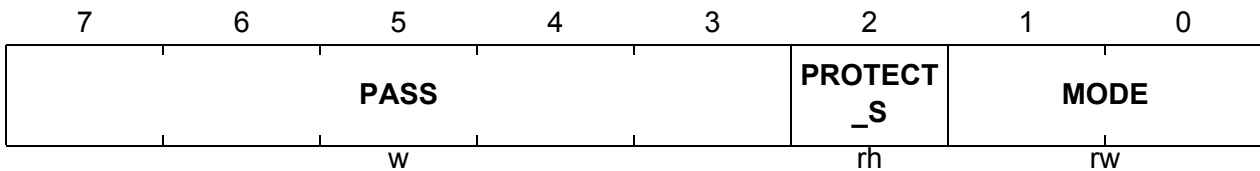

Field	Bits	Type	Description
<b>MODE</b>	[1:0]	rw	<p><b>Bit Protection Scheme Control Bits</b></p> <p>00 Scheme disabled - direct access to the protected bits is allowed.</p> <p>11 Scheme enabled - the bit field PASS has to be written with the passwords to open and close the access to protected bits. (default)</p> <p>Others: Scheme Enabled.</p> <p>These two bits cannot be written directly. To change the value between 11<sub>B</sub> and 00<sub>B</sub>, the bit field PASS must be written with 11000<sub>B</sub>; only then, will the MODE[1:0] be registered.</p>
<b>PROTECT_S</b>	2	rh	<p><b>Bit Protection Signal Status Bit</b></p> <p>This bit shows the status of the protection.</p> <p>0 Software is able to write to all protected bits.</p> <p>1 Software is unable to write to any protected bits.</p>
<b>PASS</b>	[7:3]	w	<p><b>Password Bits</b></p> <p>The Bit Protection Scheme only recognizes three patterns.</p> <p>11000<sub>B</sub> Enables writing of the bit field MODE.</p> <p>10011<sub>B</sub> Opens access to writing of all protected bits.</p> <p>10101<sub>B</sub> Closes access to writing of all protected bits</p>

**Functional Description**
**3.2.4 XC858 Register Overview**

The SFRs of the XC858 are organized into groups according to their functional units. The contents (bits) of the SFRs are summarized in [Chapter 3.2.4.1](#) to [Chapter 3.2.4.12](#).

*Note: The addresses of the bitaddressable SFRs appear in bold typeface.*

**3.2.4.1 CPU Registers**

The CPU SFRs can be accessed in both the standard and mapped memory areas (RMAP = 0 or 1).

**Table 4 CPU Register Overview**

Addr	Register Name	Bit	7	6	5	4	3	2	1	0
RMAP = 0 or 1										
81 <sub>H</sub>	<b>SP</b> Stack Pointer Register Reset: 07 <sub>H</sub>	Bit Field	SP							
		Type	rw							
82 <sub>H</sub>	<b>DPL</b> Data Pointer Register Low Reset: 00 <sub>H</sub>	Bit Field	DPL7	DPL6	DPL5	DPL4	DPL3	DPL2	DPL1	DPL0
		Type	rw	rw	rw	rw	rw	rw	rw	rw
83 <sub>H</sub>	<b>DPH</b> Data Pointer Register High Reset: 00 <sub>H</sub>	Bit Field	DPH7	DPH6	DPH5	DPH4	DPH3	DPH2	DPH1	DPH0
		Type	rw	rw	rw	rw	rw	rw	rw	rw
87 <sub>H</sub>	<b>PCON</b> Power Control Register Reset: 00 <sub>H</sub>	Bit Field	SMOD	0			GF1	GF0	0	IDLE
		Type	rw	r			rw	rw	r	rw
88 <sub>H</sub>	<b>TCON</b> Timer Control Register Reset: 00 <sub>H</sub>	Bit Field	TF1	TR1	TF0	TR0	IE1	IT1	IE0	IT0
		Type	rwh	rw	rwh	rw	rwh	rw	rwh	rw
89 <sub>H</sub>	<b>TMOD</b> Timer Mode Register Reset: 00 <sub>H</sub>	Bit Field	GATE 1	T1S	T1M		GATE 0	T0S	T0M	
		Type	rw	rw	rw		rw	rw	rw	
8A <sub>H</sub>	<b>TL0</b> Timer 0 Register Low Reset: 00 <sub>H</sub>	Bit Field	VAL							
		Type	rwh							
8B <sub>H</sub>	<b>TL1</b> Timer 1 Register Low Reset: 00 <sub>H</sub>	Bit Field	VAL							
		Type	rwh							
8C <sub>H</sub>	<b>TH0</b> Timer 0 Register High Reset: 00 <sub>H</sub>	Bit Field	VAL							
		Type	rwh							
8D <sub>H</sub>	<b>TH1</b> Timer 1 Register High Reset: 00 <sub>H</sub>	Bit Field	VAL							
		Type	rwh							
94 <sub>H</sub>	<b>MEX1</b> Memory Extension Register 1 Reset: 00 <sub>H</sub>	Bit Field	CB				NB			
		Type	r				rw			
95 <sub>H</sub>	<b>MEX2</b> Memory Extension Register 2 Reset: 00 <sub>H</sub>	Bit Field	MCM	MCB			IB			
		Type	rw	rw			rw			
96 <sub>H</sub>	<b>MEX3</b> Memory Extension Register 3 Reset: 00 <sub>H</sub>	Bit Field	MCB1 9	0		MXB1 9	MXM	MXB		
		Type	rw	r		rw	rw	rw		

**Functional Description**
**Table 4 CPU Register Overview (cont'd)**

Addr	Register Name	Bit	7	6	5	4	3	2	1	0
97 <sub>H</sub>	<b>MEXSP</b> Reset: 7F <sub>H</sub> Memory Extension Stack Pointer Register	Bit Field	0	MXSP						
		Type	r	rwh						
98 <sub>H</sub>	<b>SCON</b> Reset: 00 <sub>H</sub> Serial Channel Control Register	Bit Field	SM0	SM1	SM2	REN	TB8	RB8	TI	RI
		Type	rw	rw	rw	rw	rw	rwh	rwh	rwh
99 <sub>H</sub>	<b>SBUF</b> Reset: 00 <sub>H</sub> Serial Data Buffer Register	Bit Field	VAL							
		Type	rwh							
A2 <sub>H</sub>	<b>EO</b> Reset: 00 <sub>H</sub> Extended Operation Register	Bit Field	0		TRAP_	EN	0			DPSE
		Type	r		rw		r			rw
A8 <sub>H</sub>	<b>IEN0</b> Reset: 00 <sub>H</sub> Interrupt Enable Register 0	Bit Field	EA	0	ET2	ES	ET1	EX1	ET0	EX0
		Type	rw	r	rw	rw	rw	rw	rw	rw
B8 <sub>H</sub>	<b>IP</b> Reset: 00 <sub>H</sub> Interrupt Priority Register	Bit Field	0		PT2	PS	PT1	PX1	PT0	PX0
		Type	r		rw	rw	rw	rw	rw	rw
B9 <sub>H</sub>	<b>IPH</b> Reset: 00 <sub>H</sub> Interrupt Priority High Register	Bit Field	0		PT2H	PSH	PT1H	PX1H	PT0H	PX0H
		Type	r		rw	rw	rw	rw	rw	rw
D0 <sub>H</sub>	<b>PSW</b> Reset: 00 <sub>H</sub> Program Status Word Register	Bit Field	CY	AC	F0	RS1	RS0	OV	F1	P
		Type	rwh	rwh	rw	rw	rw	rwh	rw	rh
E0 <sub>H</sub>	<b>ACC</b> Reset: 00 <sub>H</sub> Accumulator Register	Bit Field	ACC7	ACC6	ACC5	ACC4	ACC3	ACC2	ACC1	ACC0
		Type	rw	rw	rw	rw	rw	rw	rw	rw
E8 <sub>H</sub>	<b>IEN1</b> Reset: 00 <sub>H</sub> Interrupt Enable Register 1	Bit Field	ECCIP	ECCIP	ECCIP	ECCIP	EXM	EX2	ESSC	EADC
		Type	rw	rw	rw	rw	rw	rw	rw	rw
F0 <sub>H</sub>	<b>B</b> Reset: 00 <sub>H</sub> B Register	Bit Field	B7	B6	B5	B4	B3	B2	B1	B0
		Type	rw	rw	rw	rw	rw	rw	rw	rw
F8 <sub>H</sub>	<b>IP1</b> Reset: 00 <sub>H</sub> Interrupt Priority 1 Register	Bit Field	PCCIP	PCCIP	PCCIP	PCCIP	PXM	PX2	PSSC	PADC
		Type	rw	rw	rw	rw	rw	rw	rw	rw
F9 <sub>H</sub>	<b>IPH1</b> Reset: 00 <sub>H</sub> Interrupt Priority 1 High Register	Bit Field	PCCIP	PCCIP	PCCIP	PCCIP	PXMH	PX2H	PSSC	PADC
		Type	rw	rw	rw	rw	rw	rw	rw	rw

**3.2.4.2 System Control Registers**

The system control SFRs can be accessed in the mapped memory area (RMAP = 0).

**Table 5 SCU Register Overview**

Addr	Register Name	Bit	7	6	5	4	3	2	1	0
RMAP = 0 or 1										
8F <sub>H</sub>	<b>SYSCON0</b> Reset: 04 <sub>H</sub> System Control Register 0	Bit Field	0		IMOD	E	0	1	0	RMAP
		Type	r		rw		r	r	r	rw

**Functional Description**
**Table 5 SCU Register Overview (cont'd)**

Addr	Register Name	Bit	7	6	5	4	3	2	1	0
RMAP = 0										
BF <sub>H</sub>	<b>SCU_PAGE</b> Page Register Reset: 00 <sub>H</sub>	Bit Field	OP		STNR		0	PAGE		
		Type	w		w		r	rwh		
RMAP = 0, PAGE 0										
B3 <sub>H</sub>	<b>MODPSEL</b> Peripheral Input Select Register Reset: 00 <sub>H</sub>	Bit Field	0	URRIS H	JTAGT DIS	JTAGT CKS	EXINT 2IS	EXINT 1IS	EXINT 0IS	URRIS
		Type	r	rw	rw	rw	rw	rw	rw	rw
B4 <sub>H</sub>	<b>IRCON0</b> Interrupt Request Register 0 Reset: 00 <sub>H</sub>	Bit Field	0	EXINT 6	EXINT 5	EXINT 4	EXINT 3	EXINT 2	EXINT 1	EXINT 0
		Type	r	rwh	rwh	rwh	rwh	rwh	rwh	rwh
B5 <sub>H</sub>	<b>IRCON1</b> Interrupt Request Register 1 Reset: 00 <sub>H</sub>	Bit Field	0	CANS RC2	CANS RC1	ADCS R1	ADCS R0	RIR	TIR	EIR
		Type	r	rwh	rwh	rwh	rwh	rwh	rwh	rwh
B6 <sub>H</sub>	<b>IRCON2</b> Interrupt Request Register 2 Reset: 00 <sub>H</sub>	Bit Field	0			CANS RC3	0			CANS RC0
		Type	r			rwh	r			rwh
B7 <sub>H</sub>	<b>EXICON0</b> External Interrupt Control Register 0 Reset: F0 <sub>H</sub>	Bit Field	EXINT3		EXINT2		EXINT1		EXINT0	
		Type	rw		rw		rw		rw	
BA <sub>H</sub>	<b>EXICON1</b> External Interrupt Control Register 1 Reset: 3F <sub>H</sub>	Bit Field	0		EXINT6		EXINT5		EXINT4	
		Type	r		rw		rw		rw	
BB <sub>H</sub>	<b>NMICON</b> NMI Control Register Reset: 00 <sub>H</sub>	Bit Field	0	NMI ECC	NMI VDDP	0	NMI OCDS	NMI FLASH	NMI PLL	NMI WDT
		Type	r	rw	rw	r	rw	rw	rw	rw
BC <sub>H</sub>	<b>NMISR</b> NMI Status Register Reset: 00 <sub>H</sub>	Bit Field	0	FNMI ECC	FNMI VDDP	0	FNMI OCDS	FNMI FLASH	FNMI PLL	FNMI WDT
		Type	r	rwh	rwh	r	rwh	rwh	rwh	rwh
BD <sub>H</sub>	<b>BCON</b> Baud Rate Control Register Reset: 20 <sub>H</sub>	Bit Field	BGSEL		NDOV EN	BRDIS	BRPRE			R
		Type	rw		rw	rw	rw			rw
BE <sub>H</sub>	<b>BG</b> Baud Rate Timer/Reload Register Reset: 00 <sub>H</sub>	Bit Field	BR_VALUE							
		Type	rwh							
E9 <sub>H</sub>	<b>FDCON</b> Fractional Divider Control Register Reset: 00 <sub>H</sub>	Bit Field	BGS	SYNE N	ERRS YN	EOFS YN	BRK	NDOV	FDM	FDEN
		Type	rw	rw	rwh	rwh	rwh	rwh	rw	rw
EA <sub>H</sub>	<b>FDSTEP</b> Fractional Divider Reload Register Reset: 00 <sub>H</sub>	Bit Field	STEP							
		Type	rw							
EB <sub>H</sub>	<b>FDRES</b> Fractional Divider Result Register Reset: 00 <sub>H</sub>	Bit Field	RESULT							
		Type	rh							
RMAP = 0, PAGE 1										

**Functional Description**
**Table 5 SCU Register Overview (cont'd)**

Addr	Register Name	Bit	7	6	5	4	3	2	1	0	
B3 <sub>H</sub>	<b>ID</b> Identity Register Reset: 49 <sub>H</sub>	Bit Field	PRODIG					VERID			
		Type	r					r			
B4 <sub>H</sub>	<b>PMCON0</b> Power Mode Control Register 0 Reset: 80 <sub>H</sub>	Bit Field	VDDP WARN	WDT RST	WKRS	WK SEL	SD	PD	WS		
		Type	rh	rwh	rwh	rw	rw	rwh	rw		
B5 <sub>H</sub>	<b>PMCON1</b> Power Mode Control Register 1 Reset: 00 <sub>H</sub>	Bit Field	0		CAN_ DIS	0	T2CC U_DIS	0	SSC_ DIS	ADC_ DIS	
		Type	r		rw	r	rw	r	rw	rw	
B6 <sub>H</sub>	<b>OSC_CON</b> OSC Control Register Reset: XX <sub>H</sub>	Bit Field	PLLRD RES	PLLBY P	PLLPD	0	XPD	OSC SS	EORD RES	EXTO SCR	
		Type	rwh	rwh	rw	r	rw	rwh	rwh	rh	
B7 <sub>H</sub>	<b>PLL_CON</b> PLL Control Register Reset: 18 <sub>H</sub>	Bit Field	NDIV						PLL <sub>R</sub>	PLL_ L OCK	
		Type	rw						rh	rh	
BA <sub>H</sub>	<b>CMCON</b> Clock Control Register Reset: 10 <sub>H</sub>	Bit Field	KDIV		0	FCCF G	CLKREL				
		Type	rw		r	rw	rw				
BB <sub>H</sub>	<b>PASSWD</b> Password Register Reset: 07 <sub>H</sub>	Bit Field	PASS					PROT ECT_ S	MODE		
		Type	w					rh	rw		
BE <sub>H</sub>	<b>COCON</b> Clock Output Control Register Reset: 00 <sub>H</sub>	Bit Field	COU <sub>T</sub> S		TLEN	0	COREL				
		Type	rw		rw	r	rw				
E9 <sub>H</sub>	<b>MISC_CON</b> Miscellaneous Control Register Reset: 00 <sub>H</sub>	Bit Field	ADCE TR0_ MUX	ADCE TR1_ MUX	0					DFLA S HEN	
		Type	rw	rw	r					rwh	
EA <sub>H</sub>	<b>PLL_CON1</b> PLL Control Register 1 Reset: 20 <sub>H</sub>	Bit Field	NDIV			PDIV					
		Type	rw			rw					
EB <sub>H</sub>	<b>CR_MISC</b> Reset Status Register Reset: 00 <sub>H</sub> or 01 <sub>H</sub>	Bit Field	0			T2CC F G	0			HDR S T	
		Type	r			rw	r			rwh	
RMAP = 0, PAGE 3											
B3 <sub>H</sub>	<b>XADDRH</b> On-chip XRAM Address Higher Order Reset: F0 <sub>H</sub>	Bit Field	ADDRH								
		Type	rw								
B4 <sub>H</sub>	<b>IRCON3</b> Interrupt Request Register 3 Reset: 00 <sub>H</sub>	Bit Field	0		CANS RC5	0			CANS RC4	0	
		Type	r		rwh	r			rwh	r	
B5 <sub>H</sub>	<b>IRCON4</b> Interrupt Request Register 4 Reset: 00 <sub>H</sub>	Bit Field	0		CANS RC7	0			CANS RC6	0	
		Type	r		rwh	r			rwh	r	
B6 <sub>H</sub>	<b>MODIEN</b> Peripheral Interrupt Enable Register Reset: 07 <sub>H</sub>	Bit Field	0			CM5E N	CM4E N	RIREN	TIREN	EIREN	
		Type	r			rw	rw	rw	rw	rw	

**Functional Description**
**Table 5 SCU Register Overview (cont'd)**

Addr	Register Name	Bit	7	6	5	4	3	2	1	0	
B7 <sub>H</sub>	<b>MODPISEL1</b> Reset: 00 <sub>H</sub> Peripheral Input Select Register 1	Bit Field	EXINT6IS			UR1RIS		T21EXIS	0		
		Type	rw			rw		rw	r		
BA <sub>H</sub>	<b>MODPISEL2</b> Reset: 00 <sub>H</sub> Peripheral Input Select Register 2	Bit Field	0			T2EXIS	T21IS	T2IS	T1IS	T0IS	
		Type	r			rw	rw	rw	rw	rw	
BB <sub>H</sub>	<b>PMCON2</b> Reset: 00 <sub>H</sub> Power Mode Control Register 2	Bit Field	0						UART1_DIS	T21_DIS	
		Type	r						rw	rw	
BD <sub>H</sub>	<b>MODSUSP</b> Reset: 01 <sub>H</sub> Module Suspend Control Register	Bit Field	0	CCTSUSP		T21SUSP	T2SUSP	0			WDT_SUSP
		Type	r	rw		rw	rw	r			rw
BE <sub>H</sub>	<b>MODPISEL3</b> Reset: 00 <sub>H</sub> Peripheral Input Select Register 3	Bit Field	0	CIS		SIS		MIS			
		Type	r	rw		rw		rw			
EA <sub>H</sub>	<b>MODPISEL4</b> Reset: 00 <sub>H</sub> Peripheral Input Select Register 4	Bit Field	0	EXINT5IS		EXINT4IS		EXINT3IS			
		Type	r	rw		rw		rw			

**3.2.4.3 WDT Registers**

The WDT SFRs can be accessed in the mapped memory area (RMAP = 1).

**Table 6 WDT Register Overview**

Addr	Register Name	Bit	7	6	5	4	3	2	1	0
RMAP = 1										
BB <sub>H</sub>	<b>WDTCON</b> Reset: 00 <sub>H</sub> Watchdog Timer Control Register	Bit Field	0	WINBEN	WDTPR	0	WDTEEN	WDTRS	WDTIN	
		Type	r	rw	rh	r	rw	rw	rw	
BC <sub>H</sub>	<b>WDTREL</b> Reset: 00 <sub>H</sub> Watchdog Timer Reload Register	Bit Field	WDTREL							
		Type	rw							
BD <sub>H</sub>	<b>WDTWINB</b> Reset: 00 <sub>H</sub> Watchdog Window-Boundary Count Register	Bit Field	WDTWINB							
		Type	rw							
BE <sub>H</sub>	<b>WDTL</b> Reset: 00 <sub>H</sub> Watchdog Timer Register Low	Bit Field	WDT							
		Type	rh							
BF <sub>H</sub>	<b>WDTH</b> Reset: 00 <sub>H</sub> Watchdog Timer Register High	Bit Field	WDT							
		Type	rh							

**3.2.4.4 Port Registers**

The Port SFRs can be accessed in the standard memory area (RMAP = 0).

**Functional Description**
**Table 7 Port Register Overview**

Addr	Register Name	Bit	7	6	5	4	3	2	1	0
RMAP = 0										
B2 <sub>H</sub>	<b>PORT_PAGE</b> Page Register Reset: 00 <sub>H</sub>	Bit Field	OP		STNR		0	PAGE		
		Type	w		w		r	rwh		
RMAP = 0, PAGE 0										
80 <sub>H</sub>	<b>P0_DATA</b> P0 Data Register Reset: 00 <sub>H</sub>	Bit Field	P7	P6	P5	P4	P3	P2	P1	P0
		Type	rwh	rwh	rwh	rwh	rwh	rwh	rwh	rwh
86 <sub>H</sub>	<b>P0_DIR</b> P0 Direction Register Reset: 00 <sub>H</sub>	Bit Field	P7	P6	P5	P4	P3	P2	P1	P0
		Type	rw	rw	rw	rw	rw	rw	rw	rw
90 <sub>H</sub>	<b>P1_DATA</b> P1 Data Register Reset: 00 <sub>H</sub>	Bit Field	P7	P6	P5	P4	P3	P2	P1	P0
		Type	rwh	rwh	rwh	rwh	rwh	rwh	rwh	rwh
91 <sub>H</sub>	<b>P1_DIR</b> P1 Direction Register Reset: 00 <sub>H</sub>	Bit Field	P7	P6	P5	P4	P3	P2	P1	P0
		Type	rw	rw	rw	rw	rw	rw	rw	rw
92 <sub>H</sub>	<b>P5_DATA</b> P5 Data Register Reset: 00 <sub>H</sub>	Bit Field	P7	P6	P5	P4	P3	P2	P1	P0
		Type	rwh	rwh	rwh	rwh	rwh	rwh	rwh	rwh
93 <sub>H</sub>	<b>P5_DIR</b> P5 Direction Register Reset: 00 <sub>H</sub>	Bit Field	P7	P6	P5	P4	P3	P2	P1	P0
		Type	rw	rw	rw	rw	rw	rw	rw	rw
B0 <sub>H</sub>	<b>P3_DATA</b> P3 Data Register Reset: 00 <sub>H</sub>	Bit Field	P7	P6	P5	P4	P3	P2	P1	P0
		Type	rwh	rwh	rwh	rwh	rwh	rwh	rwh	rwh
B1 <sub>H</sub>	<b>P3_DIR</b> P3 Direction Register Reset: 00 <sub>H</sub>	Bit Field	P7	P6	P5	P4	P3	P2	P1	P0
		Type	rw	rw	rw	rw	rw	rw	rw	rw
C8 <sub>H</sub>	<b>P4_DATA</b> P4 Data Register Reset: 00 <sub>H</sub>	Bit Field	P7	P6	P5	P4	P3	P2	P1	P0
		Type	rwh	rwh	rwh	rwh	rwh	rwh	rwh	rwh
C9 <sub>H</sub>	<b>P4_DIR</b> P4 Direction Register Reset: 00 <sub>H</sub>	Bit Field	P7	P6	P5	P4	P3	P2	P1	P0
		Type	rw	rw	rw	rw	rw	rw	rw	rw
RMAP = 0, PAGE 1										
80 <sub>H</sub>	<b>P0_PUDESC</b> P0 Pull-Up/Pull-Down Select Register Reset: FF <sub>H</sub>	Bit Field	P7	P6	P5	P4	P3	P2	P1	P0
		Type	rw	rw	rw	rw	rw	rw	rw	rw
86 <sub>H</sub>	<b>P0_PUEN</b> P0 Pull-Up/Pull-Down Enable Register Reset: C4 <sub>H</sub>	Bit Field	P7	P6	P5	P4	P3	P2	P1	P0
		Type	rw	rw	rw	rw	rw	rw	rw	rw
90 <sub>H</sub>	<b>P1_PUDESC</b> P1 Pull-Up/Pull-Down Select Register Reset: FF <sub>H</sub>	Bit Field	P7	P6	P5	P4	P3	P2	P1	P0
		Type	rw	rw	rw	rw	rw	rw	rw	rw
91 <sub>H</sub>	<b>P1_PUEN</b> P1 Pull-Up/Pull-Down Enable Register Reset: FF <sub>H</sub>	Bit Field	P7	P6	P5	P4	P3	P2	P1	P0
		Type	rw	rw	rw	rw	rw	rw	rw	rw
92 <sub>H</sub>	<b>P5_PUDESC</b> P5 Pull-Up/Pull-Down Select Register Reset: FF <sub>H</sub>	Bit Field	P7	P6	P5	P4	P3	P2	P1	P0
		Type	rw	rw	rw	rw	rw	rw	rw	rw
93 <sub>H</sub>	<b>P5_PUEN</b> P5 Pull-Up/Pull-Down Enable Register Reset: FF <sub>H</sub>	Bit Field	P7	P6	P5	P4	P3	P2	P1	P0
		Type	rw	rw	rw	rw	rw	rw	rw	rw

**Functional Description**
**Table 7 Port Register Overview (cont'd)**

Addr	Register Name	Bit	7	6	5	4	3	2	1	0
B0 <sub>H</sub>	<b>P3_PUDSEL</b> <b>Reset: BF<sub>H</sub></b> P3 Pull-Up/Pull-Down Select Register	Bit Field	P7	P6	P5	P4	P3	P2	P1	P0
		Type	rw	rw	rw	rw	rw	rw	rw	rw
B1 <sub>H</sub>	<b>P3_PUDEN</b> <b>Reset: 40<sub>H</sub></b> P3 Pull-Up/Pull-Down Enable Register	Bit Field	P7	P6	P5	P4	P3	P2	P1	P0
		Type	rw	rw	rw	rw	rw	rw	rw	rw
C8 <sub>H</sub>	<b>P4_PUDSEL</b> <b>Reset: FF<sub>H</sub></b> P4 Pull-Up/Pull-Down Select Register	Bit Field	P7	P6	P5	P4	P3	P2	P1	P0
		Type	rw	rw	rw	rw	rw	rw	rw	rw
C9 <sub>H</sub>	<b>P4_PUDEN</b> <b>Reset: 04<sub>H</sub></b> P4 Pull-Up/Pull-Down Enable Register	Bit Field	P7	P6	P5	P4	P3	P2	P1	P0
		Type	rw	rw	rw	rw	rw	rw	rw	rw
RMAP = 0, PAGE 2										
80 <sub>H</sub>	<b>P0_ALTSEL0</b> <b>Reset: 00<sub>H</sub></b> P0 Alternate Select 0 Register	Bit Field	P7	P6	P5	P4	P3	P2	P1	P0
		Type	rw	rw	rw	rw	rw	rw	rw	rw
86 <sub>H</sub>	<b>P0_ALTSEL1</b> <b>Reset: 00<sub>H</sub></b> P0 Alternate Select 1 Register	Bit Field	P7	P6	P5	P4	P3	P2	P1	P0
		Type	rw	rw	rw	rw	rw	rw	rw	rw
90 <sub>H</sub>	<b>P1_ALTSEL0</b> <b>Reset: 00<sub>H</sub></b> P1 Alternate Select 0 Register	Bit Field	P7	P6	P5	P4	P3	P2	P1	P0
		Type	rw	rw	rw	rw	rw	rw	rw	rw
91 <sub>H</sub>	<b>P1_ALTSEL1</b> <b>Reset: 00<sub>H</sub></b> P1 Alternate Select 1 Register	Bit Field	P7	P6	P5	P4	P3	P2	P1	P0
		Type	rw	rw	rw	rw	rw	rw	rw	rw
92 <sub>H</sub>	<b>P5_ALTSEL0</b> <b>Reset: 00<sub>H</sub></b> P5 Alternate Select 0 Register	Bit Field	P7	P6	P5	P4	P3	P2	P1	P0
		Type	rw	rw	rw	rw	rw	rw	rw	rw
93 <sub>H</sub>	<b>P5_ALTSEL1</b> <b>Reset: 00<sub>H</sub></b> P5 Alternate Select 1 Register	Bit Field	P7	P6	P5	P4	P3	P2	P1	P0
		Type	rw	rw	rw	rw	rw	rw	rw	rw
B0 <sub>H</sub>	<b>P3_ALTSEL0</b> <b>Reset: 00<sub>H</sub></b> P3 Alternate Select 0 Register	Bit Field	P7	P6	P5	P4	P3	P2	P1	P0
		Type	rw	rw	rw	rw	rw	rw	rw	rw
B1 <sub>H</sub>	<b>P3_ALTSEL1</b> <b>Reset: 00<sub>H</sub></b> P3 Alternate Select 1 Register	Bit Field	P7	P6	P5	P4	P3	P2	P1	P0
		Type	rw	rw	rw	rw	rw	rw	rw	rw
C8 <sub>H</sub>	<b>P4_ALTSEL0</b> <b>Reset: 00<sub>H</sub></b> P4 Alternate Select 0 Register	Bit Field	P7	P6	P5	P4	P3	P2	P1	P0
		Type	rw	rw	rw	rw	rw	rw	rw	rw
C9 <sub>H</sub>	<b>P4_ALTSEL1</b> <b>Reset: 00<sub>H</sub></b> P4 Alternate Select 1 Register	Bit Field	P7	P6	P5	P4	P3	P2	P1	P0
		Type	rw	rw	rw	rw	rw	rw	rw	rw
RMAP = 0, PAGE 3										
80 <sub>H</sub>	<b>P0_OD</b> <b>Reset: 00<sub>H</sub></b> P0 Open Drain Control Register	Bit Field	P7	P6	P5	P4	P3	P2	P1	P0
		Type	rw	rw	rw	rw	rw	rw	rw	rw
86 <sub>H</sub>	<b>P0_DS</b> <b>Reset: FF<sub>H</sub></b> P0 Drive Strength Control Register	Bit Field	P7	P6	P5	P4	P3	P2	P1	P0
		Type	rw	rw	rw	rw	rw	rw	rw	rw
90 <sub>H</sub>	<b>P1_OD</b> <b>Reset: 00<sub>H</sub></b> P1 Open Drain Control Register	Bit Field	P7	P6	P5	P4	P3	P2	P1	P0
		Type	rw	rw	rw	rw	rw	rw	rw	rw

**Functional Description**
**Table 7 Port Register Overview (cont'd)**

Addr	Register Name	Bit	7	6	5	4	3	2	1	0
91 <sub>H</sub>	<b>P1_DS</b> <b>Reset: FF<sub>H</sub></b> P1 Drive Strength Control Register	Bit Field	P7	P6	P5	P4	P3	P2	P1	P0
		Type	rw	rw	rw	rw	rw	rw	rw	rw
92 <sub>H</sub>	<b>P5_OD</b> <b>Reset: 00<sub>H</sub></b> P5 Open Drain Control Register	Bit Field	P7	P6	P5	P4	P3	P2	P1	P0
		Type	rw	rw	rw	rw	rw	rw	rw	rw
93 <sub>H</sub>	<b>P5_DS</b> <b>Reset: FF<sub>H</sub></b> P5 Drive Strength Control Register	Bit Field	P7	P6	P5	P4	P3	P2	P1	P0
		Type	rw	rw	rw	rw	rw	rw	rw	rw
B0 <sub>H</sub>	<b>P3_OD</b> <b>Reset: 00<sub>H</sub></b> P3 Open Drain Control Register	Bit Field	P7	P6	P5	P4	P3	P2	P1	P0
		Type	rw	rw	rw	rw	rw	rw	rw	rw
B1 <sub>H</sub>	<b>P3_DS</b> <b>Reset: FF<sub>H</sub></b> P3 Drive Strength Control Register	Bit Field	P7	P6	P5	P4	P3	P2	P1	P0
		Type	rw	rw	rw	rw	rw	rw	rw	rw
C8 <sub>H</sub>	<b>P4_OD</b> <b>Reset: 00<sub>H</sub></b> P4 Open Drain Control Register	Bit Field	P7	P6	P5	P4	P3	P2	P1	P0
		Type	rw	rw	rw	rw	rw	rw	rw	rw
C9 <sub>H</sub>	<b>P4_DS</b> <b>Reset: FF<sub>H</sub></b> P4 Drive Strength Control Register	Bit Field	P7	P6	P5	P4	P3	P2	P1	P0
		Type	rw	rw	rw	rw	rw	rw	rw	rw

**3.2.4.5 ADC Registers**

The ADC SFRs can be accessed in the standard memory area (RMAP = 0).

**Table 8 ADC Register Overview**

Addr	Register Name	Bit	7	6	5	4	3	2	1	0
RMAP = 0										
D1 <sub>H</sub>	<b>ADC_PAGE</b> <b>Reset: 00<sub>H</sub></b> Page Register	Bit Field	OP		STNR		0	PAGE		
		Type	w		w		r	rw		
RMAP = 0, PAGE 0										
CA <sub>H</sub>	<b>ADC_GLOBCTR</b> <b>Reset: 30<sub>H</sub></b> Global Control Register	Bit Field	ANON	DW	CTC		0			
		Type	rw	rw	rw		r			
CB <sub>H</sub>	<b>ADC_GLOBSTR</b> <b>Reset: 00<sub>H</sub></b> Global Status Register	Bit Field	0		CHNR			0	SAMP LE	BUSY
		Type	r		rh			r	rh	rh
CC <sub>H</sub>	<b>ADC_PRAR</b> <b>Reset: 00<sub>H</sub></b> Priority and Arbitration Register	Bit Field	ASEN 1	ASEN 0	0	ARBM	CSM1	PRI01	CSM0	PRI00
		Type	rw	rw	r	rw	rw	rw	rw	rw
CD <sub>H</sub>	<b>ADC_LCBR</b> <b>Reset: B7<sub>H</sub></b> Limit Check Boundary Register	Bit Field	BOUND1				BOUND0			
		Type	rw				rw			
CE <sub>H</sub>	<b>ADC_INPCR0</b> <b>Reset: 00<sub>H</sub></b> Input Class 0 Register	Bit Field	STC							
		Type	rw							

**Functional Description**
**Table 8 ADC Register Overview (cont'd)**

Addr	Register Name	Bit	7	6	5	4	3	2	1	0
CF <sub>H</sub>	<b>ADC_ETRCR</b> Reset: 00 <sub>H</sub> External Trigger Control Register	Bit Field	SYNE N1	SYNE N0	ETRSEL1			ETRSEL0		
		Type	rw	rw	rw			rw		
RMAP = 0, PAGE 1										
CA <sub>H</sub>	<b>ADC_CHCTR0</b> Reset: 00 <sub>H</sub> Channel Control Register 0	Bit Field	0	LCC			0	RESRSEL		
		Type	r	rw			r	rw		
CB <sub>H</sub>	<b>ADC_CHCTR1</b> Reset: 00 <sub>H</sub> Channel Control Register 1	Bit Field	0	LCC			0	RESRSEL		
		Type	r	rw			r	rw		
CC <sub>H</sub>	<b>ADC_CHCTR2</b> Reset: 00 <sub>H</sub> Channel Control Register 2	Bit Field	0	LCC			0	RESRSEL		
		Type	r	rw			r	rw		
CD <sub>H</sub>	<b>ADC_CHCTR3</b> Reset: 00 <sub>H</sub> Channel Control Register 3	Bit Field	0	LCC			0	RESRSEL		
		Type	r	rw			r	rw		
CE <sub>H</sub>	<b>ADC_CHCTR4</b> Reset: 00 <sub>H</sub> Channel Control Register 4	Bit Field	0	LCC			0	RESRSEL		
		Type	r	rw			r	rw		
CF <sub>H</sub>	<b>ADC_CHCTR5</b> Reset: 00 <sub>H</sub> Channel Control Register 5	Bit Field	0	LCC			0	RESRSEL		
		Type	r	rw			r	rw		
D2 <sub>H</sub>	<b>ADC_CHCTR6</b> Reset: 00 <sub>H</sub> Channel Control Register 6	Bit Field	0	LCC			0	RESRSEL		
		Type	r	rw			r	rw		
D3 <sub>H</sub>	<b>ADC_CHCTR7</b> Reset: 00 <sub>H</sub> Channel Control Register 7	Bit Field	0	LCC			0	RESRSEL		
		Type	r	rw			r	rw		
RMAP = 0, PAGE 2										
CA <sub>H</sub>	<b>ADC_RESR0L</b> Reset: 00 <sub>H</sub> Result Register 0 Low	Bit Field	RESULT		0	VF	DRC	CHNR		
		Type	rh		r	rh	rh	rh		
CB <sub>H</sub>	<b>ADC_RESR0H</b> Reset: 00 <sub>H</sub> Result Register 0 High	Bit Field	RESULT							
		Type	rh							
CC <sub>H</sub>	<b>ADC_RESR1L</b> Reset: 00 <sub>H</sub> Result Register 1 Low	Bit Field	RESULT		0	VF	DRC	CHNR		
		Type	rh		r	rh	rh	rh		
CD <sub>H</sub>	<b>ADC_RESR1H</b> Reset: 00 <sub>H</sub> Result Register 1 High	Bit Field	RESULT							
		Type	rh							
CE <sub>H</sub>	<b>ADC_RESR2L</b> Reset: 00 <sub>H</sub> Result Register 2 Low	Bit Field	RESULT		0	VF	DRC	CHNR		
		Type	rh		r	rh	rh	rh		
CF <sub>H</sub>	<b>ADC_RESR2H</b> Reset: 00 <sub>H</sub> Result Register 2 High	Bit Field	RESULT							
		Type	rh							
D2 <sub>H</sub>	<b>ADC_RESR3L</b> Reset: 00 <sub>H</sub> Result Register 3 Low	Bit Field	RESULT		0	VF	DRC	CHNR		
		Type	rh		r	rh	rh	rh		
D3 <sub>H</sub>	<b>ADC_RESR3H</b> Reset: 00 <sub>H</sub> Result Register 3 High	Bit Field	RESULT							
		Type	rh							
RMAP = 0, PAGE 3										

**Functional Description**
**Table 8 ADC Register Overview (cont'd)**

Addr	Register Name	Bit	7	6	5	4	3	2	1	0
CA <sub>H</sub>	<b>ADC_RESRA0L</b> Reset: 00 <sub>H</sub> Result Register 0, View A Low	Bit Field	RESULT			VF	DRC	CHNR		
		Type	rh			rh	rh	rh		
CB <sub>H</sub>	<b>ADC_RESRA0H</b> Reset: 00 <sub>H</sub> Result Register 0, View A High	Bit Field	RESULT							
		Type	rh							
CC <sub>H</sub>	<b>ADC_RESRA1L</b> Reset: 00 <sub>H</sub> Result Register 1, View A Low	Bit Field	RESULT			VF	DRC	CHNR		
		Type	rh			rh	rh	rh		
CD <sub>H</sub>	<b>ADC_RESRA1H</b> Reset: 00 <sub>H</sub> Result Register 1, View A High	Bit Field	RESULT							
		Type	rh							
CE <sub>H</sub>	<b>ADC_RESRA2L</b> Reset: 00 <sub>H</sub> Result Register 2, View A Low	Bit Field	RESULT			VF	DRC	CHNR		
		Type	rh			rh	rh	rh		
CF <sub>H</sub>	<b>ADC_RESRA2H</b> Reset: 00 <sub>H</sub> Result Register 2, View A High	Bit Field	RESULT							
		Type	rh							
D2 <sub>H</sub>	<b>ADC_RESRA3L</b> Reset: 00 <sub>H</sub> Result Register 3, View A Low	Bit Field	RESULT			VF	DRC	CHNR		
		Type	rh			rh	rh	rh		
D3 <sub>H</sub>	<b>ADC_RESRA3H</b> Reset: 00 <sub>H</sub> Result Register 3, View A High	Bit Field	RESULT							
		Type	rh							
RMAP = 0, PAGE 4										
CA <sub>H</sub>	<b>ADC_RCR0</b> Reset: 00 <sub>H</sub> Result Control Register 0	Bit Field	VFCT R	WFR	0	IEN	0			DRCT R
		Type	rw	rw	r	rw	r			rw
CB <sub>H</sub>	<b>ADC_RCR1</b> Reset: 00 <sub>H</sub> Result Control Register 1	Bit Field	VFCT R	WFR	0	IEN	0			DRCT R
		Type	rw	rw	r	rw	r			rw
CC <sub>H</sub>	<b>ADC_RCR2</b> Reset: 00 <sub>H</sub> Result Control Register 2	Bit Field	VFCT R	WFR	0	IEN	0			DRCT R
		Type	rw	rw	r	rw	r			rw
CD <sub>H</sub>	<b>ADC_RCR3</b> Reset: 00 <sub>H</sub> Result Control Register 3	Bit Field	VFCT R	WFR	0	IEN	0			DRCT R
		Type	rw	rw	r	rw	r			rw
CE <sub>H</sub>	<b>ADC_VFCR</b> Reset: 00 <sub>H</sub> Valid Flag Clear Register	Bit Field	0				VFC3	VFC2	VFC1	VFC0
		Type	r				w	w	w	w
RMAP = 0, PAGE 5										
CA <sub>H</sub>	<b>ADC_CHINFR</b> Reset: 00 <sub>H</sub> Channel Interrupt Flag Register	Bit Field	CHINF 7	CHINF 6	CHINF 5	CHINF 4	CHINF 3	CHINF 2	CHINF 1	CHINF 0
		Type	rh	rh	rh	rh	rh	rh	rh	rh
CB <sub>H</sub>	<b>ADC_CHINCR</b> Reset: 00 <sub>H</sub> Channel Interrupt Clear Register	Bit Field	CHINC 7	CHINC 6	CHINC 5	CHINC 4	CHINC 3	CHINC 2	CHINC 1	CHINC 0
		Type	w	w	w	w	w	w	w	w
CC <sub>H</sub>	<b>ADC_CHINSR</b> Reset: 00 <sub>H</sub> Channel Interrupt Set Register	Bit Field	CHINS 7	CHINS 6	CHINS 5	CHINS 4	CHINS 3	CHINS 2	CHINS 1	CHINS 0
		Type	w	w	w	w	w	w	w	w

**Functional Description**
**Table 8 ADC Register Overview (cont'd)**

Addr	Register Name	Bit	7	6	5	4	3	2	1	0
CD <sub>H</sub>	<b>ADC_CHINPR</b> Reset: 00 <sub>H</sub> Channel Interrupt Node Pointer Register	Bit Field	CHINP 7	CHINP 6	CHINP 5	CHINP 4	CHINP 3	CHINP 2	CHINP 1	CHINP 0
		Type	rw	rw	rw	rw	rw	rw	rw	rw
CE <sub>H</sub>	<b>ADC_EVINFR</b> Reset: 00 <sub>H</sub> Event Interrupt Flag Register	Bit Field	EVINF 7	EVINF 6	EVINF 5	EVINF 4	0		EVINF 1	EVINF 0
		Type	rh	rh	rh	rh	r		rh	rh
CF <sub>H</sub>	<b>ADC_EVINCR</b> Reset: 00 <sub>H</sub> Event Interrupt Clear Flag Register	Bit Field	EVINC 7	EVINC 6	EVINC 5	EVINC 4	0		EVINC 1	EVINC 0
		Type	w	w	w	w	r		w	w
D2 <sub>H</sub>	<b>ADC_EVINSR</b> Reset: 00 <sub>H</sub> Event Interrupt Set Flag Register	Bit Field	EVINS 7	EVINS 6	EVINS 5	EVINS 4	0		EVINS 1	EVINS 0
		Type	w	w	w	w	r		w	w
D3 <sub>H</sub>	<b>ADC_EVINPR</b> Reset: 00 <sub>H</sub> Event Interrupt Node Pointer Register	Bit Field	EVINP 7	EVINP 6	EVINP 5	EVINP 4	0		EVINP 1	EVINP 0
		Type	rw	rw	rw	rw	r		rw	rw
RMAP = 0, PAGE 6										
CA <sub>H</sub>	<b>ADC_CRCR1</b> Reset: 00 <sub>H</sub> Conversion Request Control Register 1	Bit Field	CH7	CH6	CH5	CH4	0			
		Type	rwh	rwh	rwh	rwh	r			
CB <sub>H</sub>	<b>ADC_CRPR1</b> Reset: 00 <sub>H</sub> Conversion Request Pending Register 1	Bit Field	CHP7	CHP6	CHP5	CHP4	0			
		Type	rwh	rwh	rwh	rwh	r			
CC <sub>H</sub>	<b>ADC_CRMR1</b> Reset: 00 <sub>H</sub> Conversion Request Mode Register 1	Bit Field	Rsv	LDEV	CLRP ND	SCAN	ENSI	ENTR	0	ENGT
		Type	r	w	w	rw	rw	rw	r	rw
CD <sub>H</sub>	<b>ADC_QMR0</b> Reset: 00 <sub>H</sub> Queue Mode Register 0	Bit Field	CEV	TREV	FLUS H	CLRV	0	ENTR	0	ENGT
		Type	w	w	w	w	r	rw	r	rw
CE <sub>H</sub>	<b>ADC_QSR0</b> Reset: 20 <sub>H</sub> Queue Status Register 0	Bit Field	Rsv	0	EMPT Y	EV	0		FILL	
		Type	r	r	rh	rh	r		rh	
CF <sub>H</sub>	<b>ADC_Q0R0</b> Reset: 00 <sub>H</sub> Queue 0 Register 0	Bit Field	EXTR	ENSI	RF	V	0	REQCHNR		
		Type	rh	rh	rh	rh	r	rh		
D2 <sub>H</sub>	<b>ADC_QBUR0</b> Reset: 00 <sub>H</sub> Queue Backup Register 0	Bit Field	EXTR	ENSI	RF	V	0	REQCHNR		
		Type	rh	rh	rh	rh	r	rh		
D2 <sub>H</sub>	<b>ADC_QINR0</b> Reset: 00 <sub>H</sub> Queue Input Register 0	Bit Field	EXTR	ENSI	RF	0		REQCHNR		
		Type	w	w	w	r		w		

**Functional Description**
**3.2.4.6 Timer 2 Compare/Capture Unit Registers**

The Timer 2 Compare/Capture Unit SFRs can be accessed in the standard memory area (RMAP = 0).

**Table 9 T2CCU Register Overview**

Addr	Register Name	Bit	7	6	5	4	3	2	1	0
RMAP = 0										
C7 <sub>H</sub>	<b>T2_PAGE</b> Page Register Reset: 00 <sub>H</sub>	Bit Field	OP		STNR		0	PAGE		
		Type	w		w		r	rwh		
RMAP = 0, PAGE 0										
C0 <sub>H</sub>	<b>T2_T2CON</b> Timer 2 Control Register Reset: 00 <sub>H</sub>	Bit Field	TF2	EXF2	0		EXEN 2	TR2	C/ $\overline{T}2$	CP/ RL2
		Type	rwh	rwh	r		rw	rwh	rw	rw
C1 <sub>H</sub>	<b>T2_T2MOD</b> Timer 2 Mode Register Reset: 00 <sub>H</sub>	Bit Field	T2RE GS	T2RH EN	EDGE SEL	PREN	T2PRE			DCEN
		Type	rw	rw	rw	rw	rw			rw
C2 <sub>H</sub>	<b>T2_RC2L</b> Timer 2 Reload/Capture Register Low Reset: 00 <sub>H</sub>	Bit Field	RC2							
		Type	rwh							
C3 <sub>H</sub>	<b>T2_RC2H</b> Timer 2 Reload/Capture Register High Reset: 00 <sub>H</sub>	Bit Field	RC2							
		Type	rwh							
C4 <sub>H</sub>	<b>T2_T2L</b> Timer 2 Register Low Reset: 00 <sub>H</sub>	Bit Field	THL2							
		Type	rwh							
C5 <sub>H</sub>	<b>T2_T2H</b> Timer 2 Register High Reset: 00 <sub>H</sub>	Bit Field	THL2							
		Type	rwh							
C6 <sub>H</sub>	<b>T2_T2CON1</b> Timer 2 Control Register 1 Reset: 03 <sub>H</sub>	Bit Field	0						TF2EN	EXF2E N
		Type	r						rw	rw
RMAP = 0, PAGE 1										
C0 <sub>H</sub>	<b>T2CCU_CCEN</b> T2CCU Capture/Compare Enable Register Reset: 00 <sub>H</sub>	Bit Field	CCM3		CCM2		CCM1		CCM0	
		Type	rw		rw		rw		rw	
C1 <sub>H</sub>	<b>T2CCU_CCTBSEL</b> T2CCU Capture/Compare Time Base Select Register Reset: 00 <sub>H</sub>	Bit Field	CASC	CCTT OV	CCTB 5	CCTB 4	CCTB 3	CCTB 2	CCTB 1	CCTB 0
		Type	rw	rwh	rw	rw	rw	rw	rw	rw
C2 <sub>H</sub>	<b>T2CCU_CCTRELL</b> T2CCU Capture/Compare Timer Reload Register Low Reset: 00 <sub>H</sub>	Bit Field	CCTREL							
		Type	rw							
C3 <sub>H</sub>	<b>T2CCU_CCTRELH</b> T2CCU Capture/Compare Timer Reload Register High Reset: 00 <sub>H</sub>	Bit Field	CCTREL							
		Type	rw							
C4 <sub>H</sub>	<b>T2CCU_CCTL</b> T2CCU Capture/Compare Timer Register Low Reset: 00 <sub>H</sub>	Bit Field	CCT							
		Type	rwh							

**Functional Description**
**Table 9 T2CCU Register Overview (cont'd)**

Addr	Register Name	Bit	7	6	5	4	3	2	1	0	
C5 <sub>H</sub>	<b>T2CCU_CCTH</b> Reset: 00 <sub>H</sub> T2CCU Capture/Compare Timer Register High	Bit Field	CCT								
		Type	rwh								
C6 <sub>H</sub>	<b>T2CCU_CCTCON</b> Reset: 00 <sub>H</sub> T2CCU Capture/Compare Timer Control Register	Bit Field	CCTPRE				CCTO VF	CCTO VEN	TIMSY N	CCTS T	
		Type	rw				rwh	rw	rw	rw	rw
RMAP = 0, PAGE 2											
C0 <sub>H</sub>	<b>T2CCU_COSHDW</b> Reset: 00 <sub>H</sub> T2CCU Capture/compare Enable Register	Bit Field	ENSH DW	TXOV	COOU T5	COOU T4	COOU T3	COOU T2	COOU T1	COOU T0	
		Type	rwh	rwh	rwh	rwh	rwh	rwh	rwh	rwh	
C1 <sub>H</sub>	<b>T2CCU_CC0L</b> Reset: 00 <sub>H</sub> T2CCU Capture/Compare Register 0 Low	Bit Field	CCVALL								
		Type	rwh								
C2 <sub>H</sub>	<b>T2CCU_CC0H</b> Reset: 00 <sub>H</sub> T2CCU Capture/compare Register 0 High	Bit Field	CCVALH								
		Type	rwh								
C3 <sub>H</sub>	<b>T2CCU_CC1L</b> Reset: 00 <sub>H</sub> T2CCU Capture/compare Register 1 Low	Bit Field	CCVALL								
		Type	rwh								
C4 <sub>H</sub>	<b>T2CCU_CC1H</b> Reset: 00 <sub>H</sub> T2CCU Capture/compare Register 1 High	Bit Field	CCVALH								
		Type	rwh								
C5 <sub>H</sub>	<b>T2CCU_CC2L</b> Reset: 00 <sub>H</sub> T2CCU Capture/compare Register 2 Low	Bit Field	CCVALL								
		Type	rwh								
C6 <sub>H</sub>	<b>T2CCU_CC2H</b> Reset: 00 <sub>H</sub> T2CCU Capture/compare Register 2 High	Bit Field	CCVALH								
		Type	rwh								
RMAP = 0, PAGE 3											
C0 <sub>H</sub>	<b>T2CCU_COCON</b> Reset: 00 <sub>H</sub> T2CCU Compare Control Register	Bit Field	CCM5	CCM4	CM5F	CM4F	POLB	POLA	COMOD		
		Type	rw	rw	rwh	rwh	rw	rw	rw		
C1 <sub>H</sub>	<b>T2CCU_CC3L</b> Reset: 00 <sub>H</sub> T2CCU Capture/compare Register 3 Low	Bit Field	CCVALL								
		Type	rwh								
C2 <sub>H</sub>	<b>T2CCU_CC3H</b> Reset: 00 <sub>H</sub> T2CCU Capture/compare Register 3 High	Bit Field	CCVALH								
		Type	rwh								
C3 <sub>H</sub>	<b>T2CCU_CC4L</b> Reset: 00 <sub>H</sub> T2CCU Capture/compare Register 4 Low	Bit Field	CCVALL								
		Type	rwh								
C4 <sub>H</sub>	<b>T2CCU_CC4H</b> Reset: 00 <sub>H</sub> T2CCU Capture/compare Register 4 High	Bit Field	CCVALH								
		Type	rwh								
C5 <sub>H</sub>	<b>T2CCU_CC5L</b> Reset: 00 <sub>H</sub> T2CCU Capture/compare Register 5 Low	Bit Field	CCVALL								
		Type	rwh								
C6 <sub>H</sub>	<b>T2CCU_CC5H</b> Reset: 00 <sub>H</sub> T2CCU Capture/compare Register 5 High	Bit Field	CCVALH								
		Type	rwh								

**Functional Description**
**Table 9 T2CCU Register Overview (cont'd)**

Addr	Register Name	Bit	7	6	5	4	3	2	1	0
RMAP = 0, PAGE 4										
C2 <sub>H</sub>	<b>T2CCU_CCTDTCL</b> Reset: 00 <sub>H</sub> T2CCU Capture/Compare Timer Dead-Time Control Register Low	Bit Field	DTM							
		Type	rw							
C3 <sub>H</sub>	<b>T2CCU_CCTDTCH</b> Reset: 00 <sub>H</sub> T2CCU Capture/Compare Timer Dead-Time Control Register High	Bit Field	DTRE S	DTR2	DTR1	DTR0	DTLEV	DTE2	DTE1	DTE0
		Type	rwh	rh	rh	rh	rw	rw	rw	rw

**3.2.4.7 Timer 21 Registers**

The Timer 21 SFRs can be accessed in the mapped memory area (RMAP = 1).

**Table 10 T21 Register Overview**

Addr	Register Name	Bit	7	6	5	4	3	2	1	0
RMAP = 1										
C0 <sub>H</sub>	<b>T21_T2CON</b> Reset: 00 <sub>H</sub> Timer 2 Control Register	Bit Field	TF2	EXF2	0	EXEN 2	TR2	C/T2	CP/ RL2	
		Type	rwh	rwh	r	rw	rwh	rw	rw	
C1 <sub>H</sub>	<b>T21_T2MOD</b> Reset: 00 <sub>H</sub> Timer 2 Mode Register	Bit Field	T2RE GS	T2RH EN	EDGE SEL	PREN	T2PRE			DCEN
		Type	rw	rw	rw	rw	rw	rw	rw	
C2 <sub>H</sub>	<b>T21_RC2L</b> Reset: 00 <sub>H</sub> Timer 2 Reload/Capture Register Low	Bit Field	RC2							
		Type	rwh							
C3 <sub>H</sub>	<b>T21_RC2H</b> Reset: 00 <sub>H</sub> Timer 2 Reload/Capture Register High	Bit Field	RC2							
		Type	rwh							
C4 <sub>H</sub>	<b>T21_T2L</b> Reset: 00 <sub>H</sub> Timer 2 Register Low	Bit Field	THL2							
		Type	rwh							
C5 <sub>H</sub>	<b>T21_T2H</b> Reset: 00 <sub>H</sub> Timer 2 Register High	Bit Field	THL2							
		Type	rwh							
C6 <sub>H</sub>	<b>T21_T2CON1</b> Reset: 03 <sub>H</sub> Timer 2 Control Register 1	Bit Field	0						TF2EN	EXF2E N
		Type	r						rw	rw

**3.2.4.8 UART1 Registers**

The UART1 SFRs can be accessed in the mapped memory area (RMAP = 1).

**Table 11 UART1 Register Overview**

Addr	Register Name	Bit	7	6	5	4	3	2	1	0
RMAP = 1										
C8 <sub>H</sub>	<b>SCON</b> <b>Reset: 00<sub>H</sub></b> Serial Channel Control Register	Bit Field	SM0	SM1	SM2	REN	TB8	RB8	TI	RI
		Type	rw	rw	rw	rw	rw	rwh	rwh	rwh
C9 <sub>H</sub>	<b>SBUF</b> <b>Reset: 00<sub>H</sub></b> Serial Data Buffer Register	Bit Field	VAL							
		Type	rwh							
CA <sub>H</sub>	<b>BCON</b> <b>Reset: 00<sub>H</sub></b> Baud Rate Control Register	Bit Field	0				BRPRE			R
		Type	r				rw			rw
CB <sub>H</sub>	<b>BG</b> <b>Reset: 00<sub>H</sub></b> Baud Rate Timer/Reload Register	Bit Field	BR_VALUE							
		Type	rwh							
CC <sub>H</sub>	<b>FDCON</b> <b>Reset: 00<sub>H</sub></b> Fractional Divider Control Register	Bit Field	0				NDOV	FDM	FDEN	
		Type	r				rwh	rw	rw	
CD <sub>H</sub>	<b>FDSTEP</b> <b>Reset: 00<sub>H</sub></b> Fractional Divider Reload Register	Bit Field	STEP							
		Type	rw							
CE <sub>H</sub>	<b>FDRES</b> <b>Reset: 00<sub>H</sub></b> Fractional Divider Result Register	Bit Field	RESULT							
		Type	rh							
CF <sub>H</sub>	<b>SCON1</b> <b>Reset: 07<sub>H</sub></b> Serial Channel Control Register 1	Bit Field	0				NDOV EN	TIEN	RIEN	
		Type	r				rw	rw	rw	

### 3.2.4.9 SSC Registers

The SSC SFRs can be accessed in the standard memory area (RMAP = 0).

**Table 12 SSC Register Overview**

Addr	Register Name	Bit	7	6	5	4	3	2	1	0
RMAP = 0										
A9 <sub>H</sub>	<b>SSC_PISEL</b> <b>Reset: 00<sub>H</sub></b> Port Input Select Register	Bit Field	0				CIS	SIS	MIS	
		Type	r				rw	rw	rw	
AA <sub>H</sub>	<b>SSC_CONL</b> <b>Reset: 00<sub>H</sub></b> Control Register Low Programming Mode	Bit Field	LB	PO	PH	HB	BM			
		Type	rw	rw	rw	rw	rw			
AA <sub>H</sub>	<b>SSC_CONL</b> <b>Reset: 00<sub>H</sub></b> Control Register Low Operating Mode	Bit Field	0				BC			
		Type	r				rh			
AB <sub>H</sub>	<b>SSC_CONH</b> <b>Reset: 00<sub>H</sub></b> Control Register High Programming Mode	Bit Field	EN	MS	0	AREN	BEN	PEN	REN	TEN
		Type	rw	rw	r	rw	rw	rw	rw	rw
AB <sub>H</sub>	<b>SSC_CONH</b> <b>Reset: 00<sub>H</sub></b> Control Register High Operating Mode	Bit Field	EN	MS	0	BSY	BE	PE	RE	TE
		Type	rw	rw	r	rh	rwh	rwh	rwh	rwh

**Table 12 SSC Register Overview (cont'd)**

Addr	Register Name	Bit	7	6	5	4	3	2	1	0
AC <sub>H</sub>	<b>SSC_TBL</b> <b>Reset: 00<sub>H</sub></b> Transmitter Buffer Register Low	Bit Field	TB_VALUE							
		Type	rw							
AD <sub>H</sub>	<b>SSC_RBL</b> <b>Reset: 00<sub>H</sub></b> Receiver Buffer Register Low	Bit Field	RB_VALUE							
		Type	rh							
AE <sub>H</sub>	<b>SSC_BRL</b> <b>Reset: 00<sub>H</sub></b> Baud Rate Timer Reload Register Low	Bit Field	BR_VALUE							
		Type	rw							
AF <sub>H</sub>	<b>SSC_BRH</b> <b>Reset: 00<sub>H</sub></b> Baud Rate Timer Reload Register High	Bit Field	BR_VALUE							
		Type	rw							

### 3.2.4.10 MultiCAN Registers

The MultiCAN SFRs can be accessed in the standard memory area (RMAP = 0).

**Table 13 CAN Register Overview**

Addr	Register Name	Bit	7	6	5	4	3	2	1	0
RMAP = 0										
D8 <sub>H</sub>	<b>ADCON</b> <b>Reset: 00<sub>H</sub></b> CAN Address/Data Control Register	Bit Field	V3	V2	V1	V0	AUAD		BSY	RWEN
		Type	rw	rw	rw	rw	rw		rh	rw
D9 <sub>H</sub>	<b>ADL</b> <b>Reset: 00<sub>H</sub></b> CAN Address Register Low	Bit Field	CA9	CA8	CA7	CA6	CA5	CA4	CA3	CA2
		Type	rwh	rwh	rwh	rwh	rwh	rwh	rwh	rwh
DA <sub>H</sub>	<b>ADH</b> <b>Reset: 00<sub>H</sub></b> CAN Address Register High	Bit Field	0				CA13	CA12	CA11	CA10
		Type	r				rwh	rwh	rwh	rwh
DB <sub>H</sub>	<b>DATA0</b> <b>Reset: 00<sub>H</sub></b> CAN Data Register 0	Bit Field	CD							
		Type	rwh							
DC <sub>H</sub>	<b>DATA1</b> <b>Reset: 00<sub>H</sub></b> CAN Data Register 1	Bit Field	CD							
		Type	rwh							
DD <sub>H</sub>	<b>DATA2</b> <b>Reset: 00<sub>H</sub></b> CAN Data Register 2	Bit Field	CD							
		Type	rwh							
DE <sub>H</sub>	<b>DATA3</b> <b>Reset: 00<sub>H</sub></b> CAN Data Register 3	Bit Field	CD							
		Type	rwh							

### 3.2.4.11 OCDS Registers

The OCDS SFRs can be accessed in the mapped memory area (RMAP = 1).

**Functional Description**
**Table 14 OCDS Register Overview**

Addr	Register Name	Bit	7	6	5	4	3	2	1	0
RMAP = 1										
E9 <sub>H</sub>	<b>MMCR2</b> Monitor Mode Control 2 Register <b>Reset: 8U<sub>H</sub></b>	Bit Field	STMO DE	EXBC	DSUS P	MBCO N	ALTDI	MMEP	MMOD E	JENA
		Type	rw	rw	rw	rwh	rw	rwh	rh	rh
EA <sub>H</sub>	<b>MEXTCR</b> Memory Extension Control Register <b>Reset: 0U<sub>H</sub></b>	Bit Field	0				BANKBPx			
		Type	r				rw			
EB <sub>H</sub>	<b>MMWR1</b> Monitor Work Register 1 <b>Reset: 00<sub>H</sub></b>	Bit Field	MMWR1							
		Type	rw							
EC <sub>H</sub>	<b>MMWR2</b> Monitor Work Register 2 <b>Reset: 00<sub>H</sub></b>	Bit Field	MMWR2							
		Type	rw							
F1 <sub>H</sub>	<b>MMCR</b> Monitor Mode Control Register <b>Reset: 00<sub>H</sub></b>	Bit Field	MEXIT _P	MEXIT	0	MSTE P	MRAM S_P	MRAM S	TRF	RRF
		Type	w	rwh	r	rw	w	rwh	rh	rh
F2 <sub>H</sub>	<b>MMSR</b> Monitor Mode Status Register <b>Reset: 00<sub>H</sub></b>	Bit Field	MBCA M	MBCIN	EXBF	SWBF	HWB3 F	HWB2 F	HWB1 F	HWB0 F
		Type	rw	rwh	rwh	rwh	rwh	rwh	rwh	rwh
F3 <sub>H</sub>	<b>MMBPCR</b> Breakpoints Control Register <b>Reset: 00<sub>H</sub></b>	Bit Field	SWBC	HWB3C		HWB2C		HWB1 C	HWB0C	
		Type	rw	rw		rw		rw	rw	
F4 <sub>H</sub>	<b>MMICR</b> Monitor Mode Interrupt Control Register <b>Reset: 00<sub>H</sub></b>	Bit Field	DVEC T	DRET R	COMR ST	MSTS EL	MMUI E_P	MMUI E	RRIE_ P	RRIE
		Type	rwh	rwh	rwh	rh	w	rw	w	rw
F5 <sub>H</sub>	<b>MMDR</b> Monitor Mode Data Transfer Register Receive <b>Reset: 00<sub>H</sub></b>	Bit Field	MMRR							
		Type	rh							
F6 <sub>H</sub>	<b>HWBPSR</b> Hardware Breakpoints Select Register <b>Reset: 00<sub>H</sub></b>	Bit Field	0			BPSEL _P	BPSEL			
		Type	r			w	rw			
F7 <sub>H</sub>	<b>HWBPDR</b> Hardware Breakpoints Data Register <b>Reset: 00<sub>H</sub></b>	Bit Field	HWBPxx							
		Type	rw							

**3.2.4.12 Flash Registers**

The Flash SFRs can be accessed in the mapped memory area (RMAP = 1).

**Table 15 Flash Register Overview**

Addr	Register Name	Bit	7	6	5	4	3	2	1	0
RMAP = 1										
D1 <sub>H</sub>	<b>FCON</b> <b>Reset: 10<sub>H</sub></b> P-Flash Control Register	Bit Field	0	FBSY	YE	1	NVST R	MAS1	ERAS E	PROG
		Type	r	rh	rwh	r	rw	rw	rw	rw
D2 <sub>H</sub>	<b>EECON</b> <b>Reset: 10<sub>H</sub></b> D-Flash Control Register	Bit Field	0	EEBS Y	YE	1	NVST R	MAS1	ERAS E	PROG
		Type	r	rh	rwh	r	rw	rw	rw	rw
D3 <sub>H</sub>	<b>FCS</b> <b>Reset: 80<sub>H</sub></b> Flash Control and Status Register	Bit Field	1	SBEIE	FTEN	0	EEDE RR	EESE RR	FDER R	FSER R
		Type	r	rw	rwh	r	rwh	rwh	rwh	rwh
D4 <sub>H</sub>	<b>FEAL</b> <b>Reset: 00<sub>H</sub></b> Flash Error Address Register, Low Byte	Bit Field	ECCEADDR							
		Type	rh							
D5 <sub>H</sub>	<b>FEAH</b> <b>Reset: 00<sub>H</sub></b> Flash Error Address Register, High Byte	Bit Field	ECCEADDR							
		Type	rh							
D6 <sub>H</sub>	<b>FTVAL</b> <b>Reset: 78<sub>H</sub></b> Flash Timer Value Register	Bit Field	MODE	OFVAL						
		Type	rw	rw						
DD <sub>H</sub>	<b>FCS1</b> <b>Reset: 00<sub>H</sub></b> Flash Control and Status Register 1	Bit Field	0							EEAB ORT
		Type	r							rwh

### 3.3 Flash Memory

The Flash memory provides an embedded user-programmable non-volatile memory, allowing fast and reliable storage of user code and data. It is operated from a single 2.5 V supply from the Embedded Voltage Regulator (EVR) and does not require additional programming or erasing voltage. The pagination of the Flash memory allows each page to be erased independently.

#### Features

- In-System Programming (ISP) via UART
- In-Application Programming (IAP)
- Error Correction Code (ECC) for dynamic correction of single-bit errors
- Background program and erase operations for CPU load minimization
- Support for aborting erase operation
- Minimum program width
  - of 1-byte for D-Flash and 2-bytes for P-Flash
- 1-page minimum erase width
- 1-byte read access
- Flash is delivered in erased state (read all ones)
- Operating supply voltage:  $2.5\text{ V} \pm 7.5\%$
- Read access time:  $1 \times t_{\text{CCLK}} = 38\text{ ns}^1$
- Program time for 1 wordline:  $1.6\text{ ms}^2$
- Page erase time: 20 ms
- Mass erase time: 200 ms

1) Values shown here are typical values.  $f_{\text{sys}} = 144\text{ MHz} \pm 7.5\%$  ( $f_{\text{CCLK}} = 24\text{ MHz} \pm 7.5\%$ ) is the maximum frequency range for Flash read access.

2) Values shown here are typical values.  $f_{\text{sys}} = 144\text{ MHz} \pm 7.5\%$  ( $f_{\text{CCLK}} = 24\text{ MHz} \pm 7.5\%$ ) is the typical frequency range for Flash programming and erasing.  $f_{\text{sysmin}}$  is used for obtaining the worst case timing.

Functional Description

Table 16 shows the Flash data retention and endurance targets for Industrial profile.

**Table 16 Flash Data Retention and Endurance for Industrial Profile  
(Operating Conditions apply)**

Retention	Endurance <sup>1)2)</sup>	Size	Remarks
<b>Program Flash</b>			
15 years	1000 cycles	up to 60 Kbytes	
<b>Data Flash</b>			
15 years	1000 cycles	4 Kbytes	
10 years	10,000 cycles	4 Kbytes	
5 years	30,000 cycles	4 Kbytes	
1 year	100,000 cycles	4 Kbytes	

1) In Program Flash, one cycle refers to the programming of all pages in the flash bank and a mass erase.

2) In Data Flash, one cycle refers to the programming of all wordlines in a page and a page erase.

### **3.3.1 Flash Bank Pagination**

The XC858 product family offers Flash devices with 64 Kbytes, 52 Kbytes or 36Kbyte of embedded Flash memory. Each Flash device consists of a Program Flash (P-Flash) and a single Data Flash (D-Flash) bank. P-Flash has 120 pages of 8 wordlines per page with 64 bytes per wordline. D-Flash has 64 pages of 2 wordlines per page with 32 bytes per wordline. Both types can be used for code and data storage. The label “Data” neither implies that the D-Flash is mapped to the data memory region, nor that it can only be used for data storage. It is used to distinguish the different page width and wordline of each Flash bank.

The internal structure of each Flash bank represents a page architecture for flexible erase capability. The minimum erase width is always a complete page. The D-Flash bank is divided into smaller size for extended erasing and reprogramming capability; even numbers for each page size are provided to allow greater flexibility and the ability to adapt to a wide range of application requirements.

### 3.4 Interrupt System

The XC800 Core supports one non-maskable interrupt (NMI) and 14 maskable interrupt requests. In addition to the standard interrupt functions supported by the core, e.g., configurable interrupt priority and interrupt masking, the XC858 interrupt system provides extended interrupt support capabilities such as the mapping of each interrupt vector to several interrupt sources to increase the number of interrupt sources supported, and additional status registers for detecting and determining the interrupt source.

#### 3.4.1 Interrupt Source

Figure 12 to Figure 16 give a general overview of the interrupt sources and nodes, and their corresponding control and status flags.

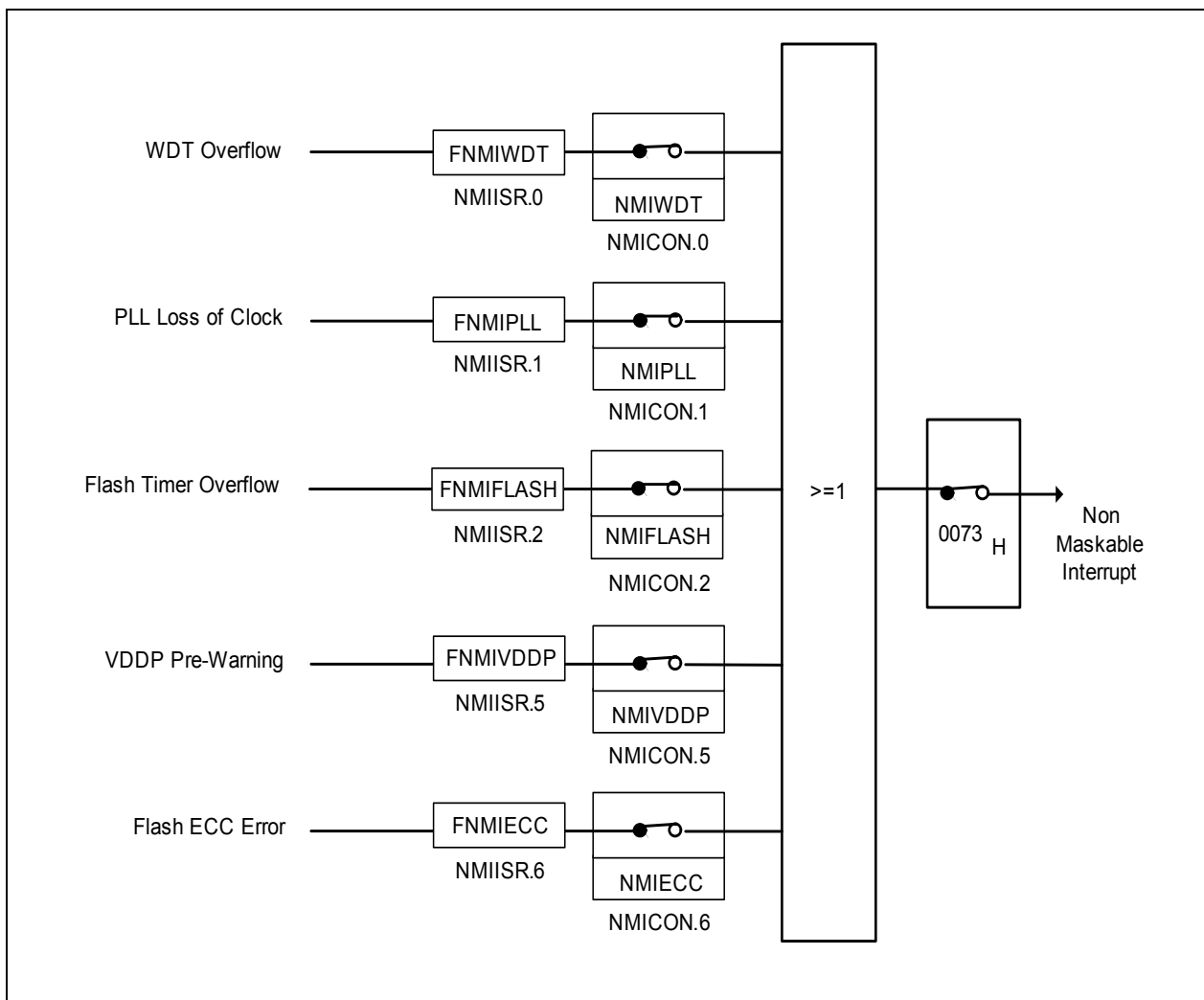

Figure 12 Non-Maskable Interrupt Request Sources

Functional Description

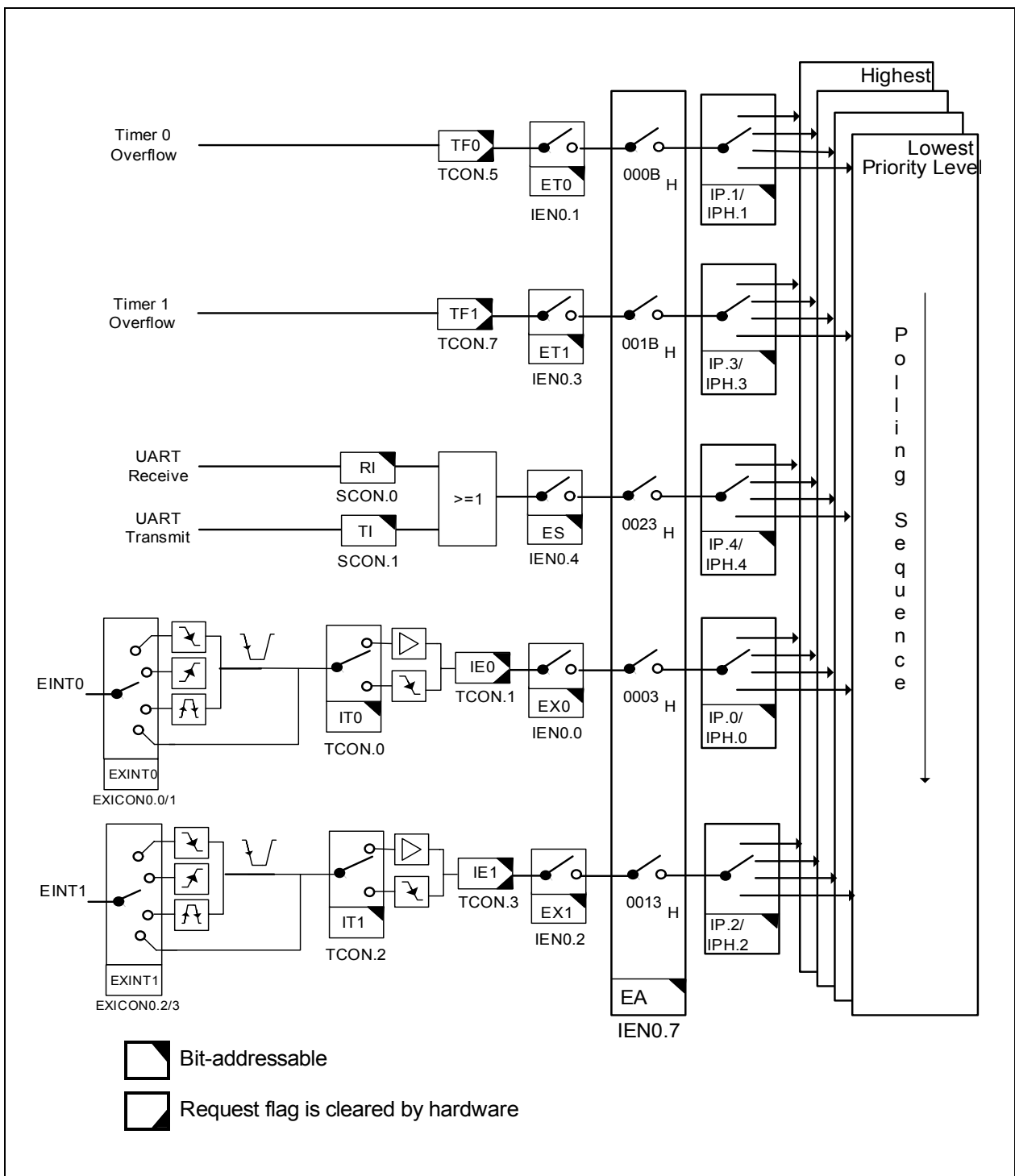

Figure 13 Interrupt Request Sources (Part 1)

Functional Description

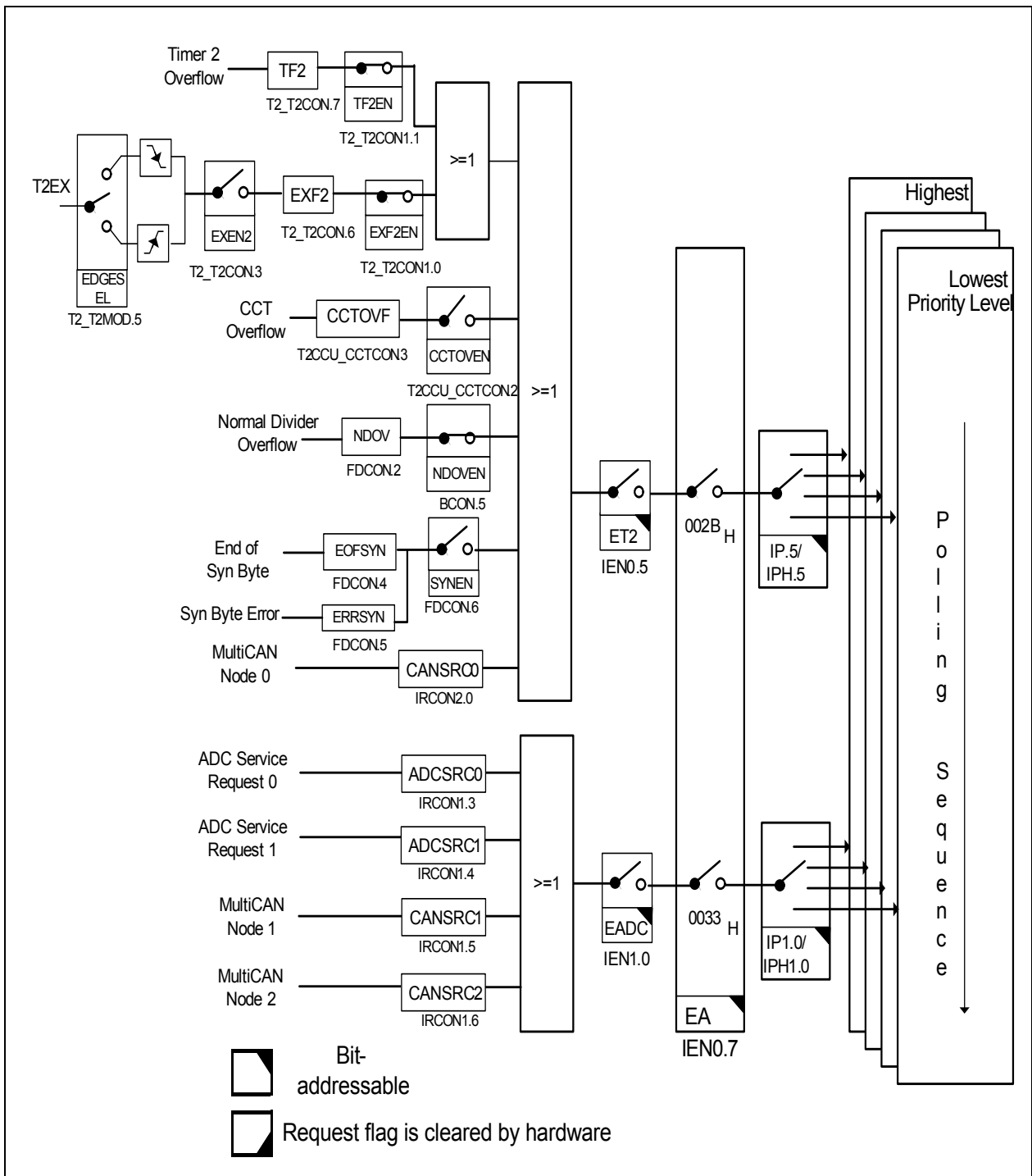

Figure 14 Interrupt Request Sources (Part 2)

Functional Description

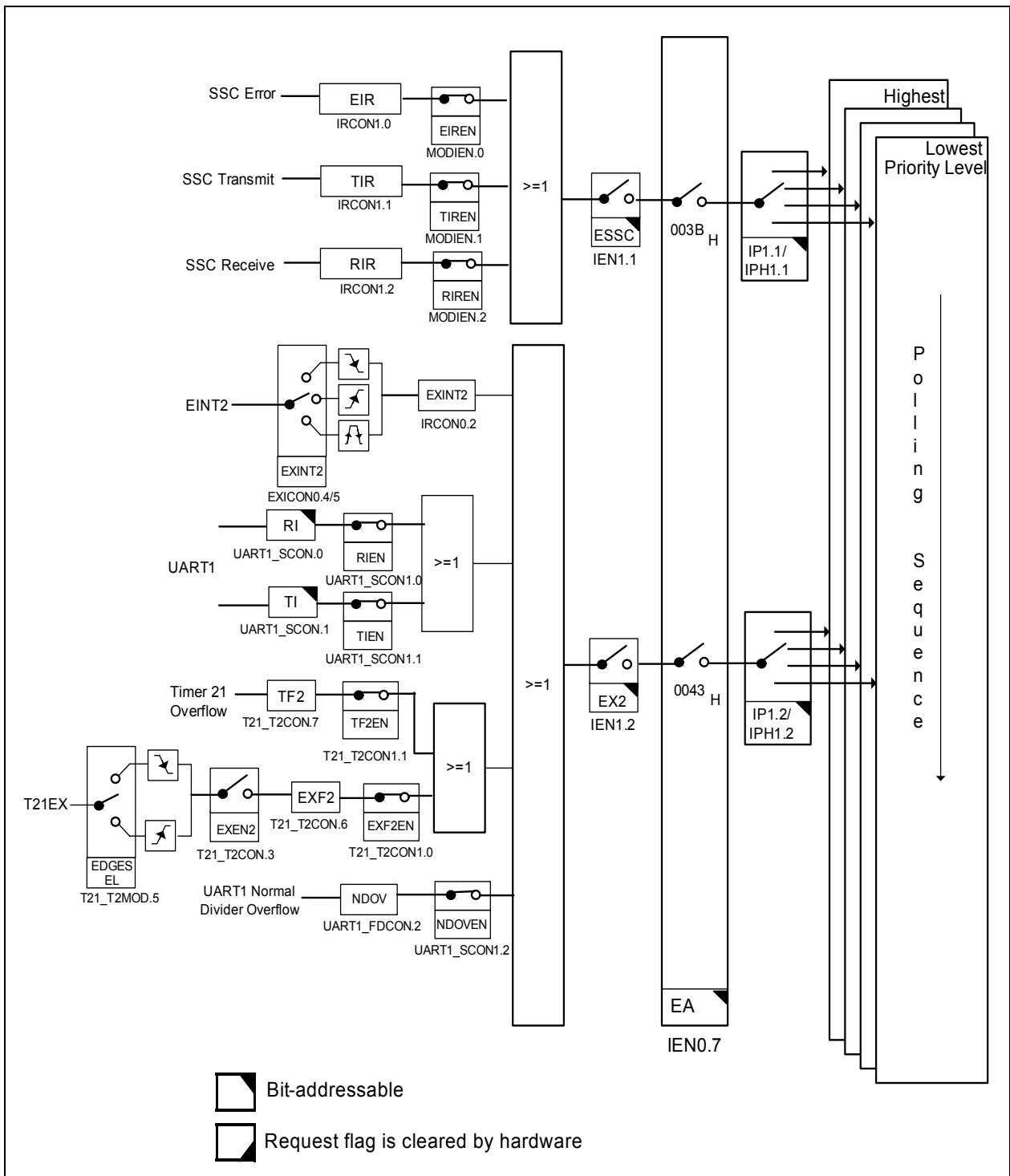

Figure 15 Interrupt Request Sources (Part 3)

Functional Description

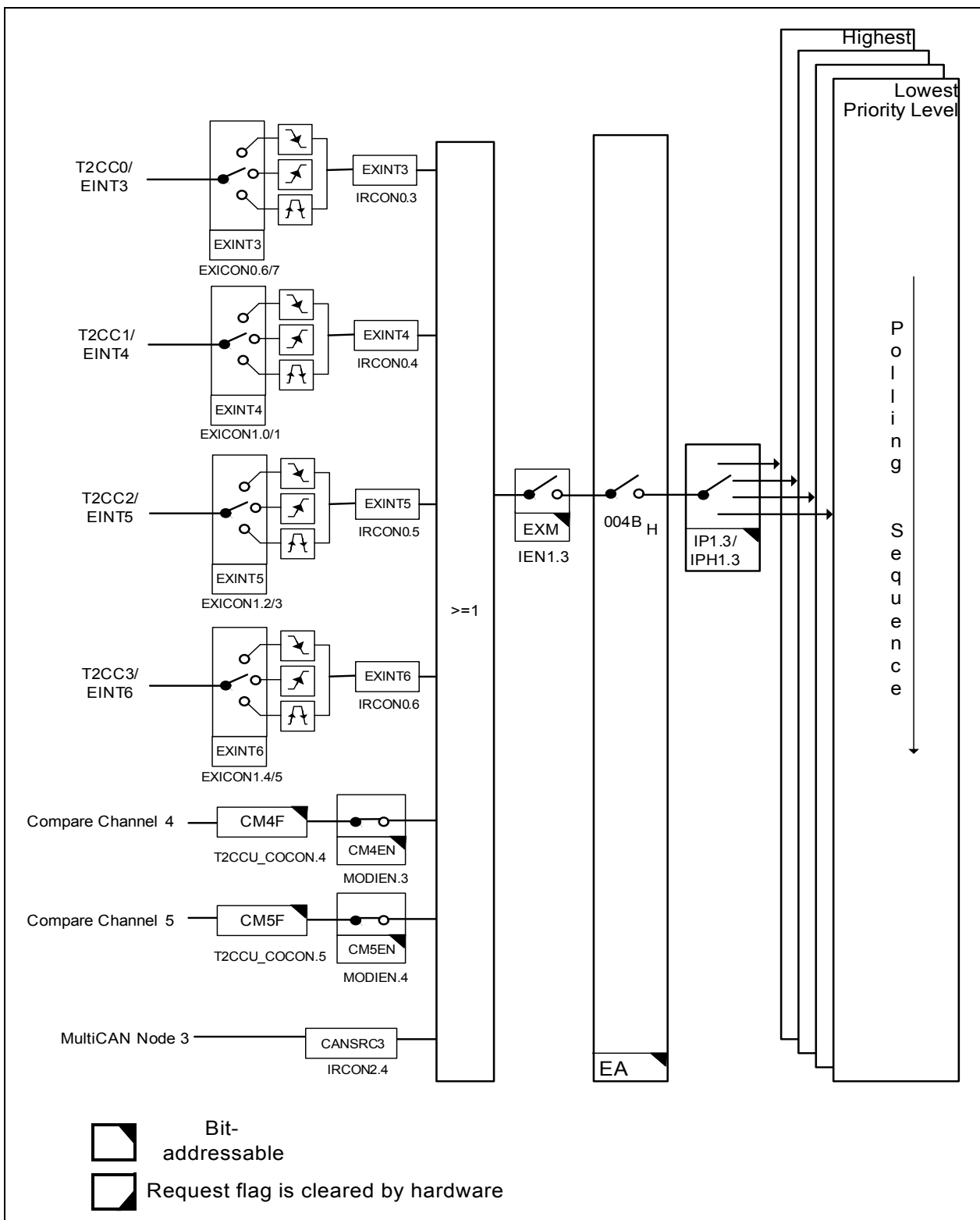

Figure 16 Interrupt Request Sources (Part 4)

Functional Description

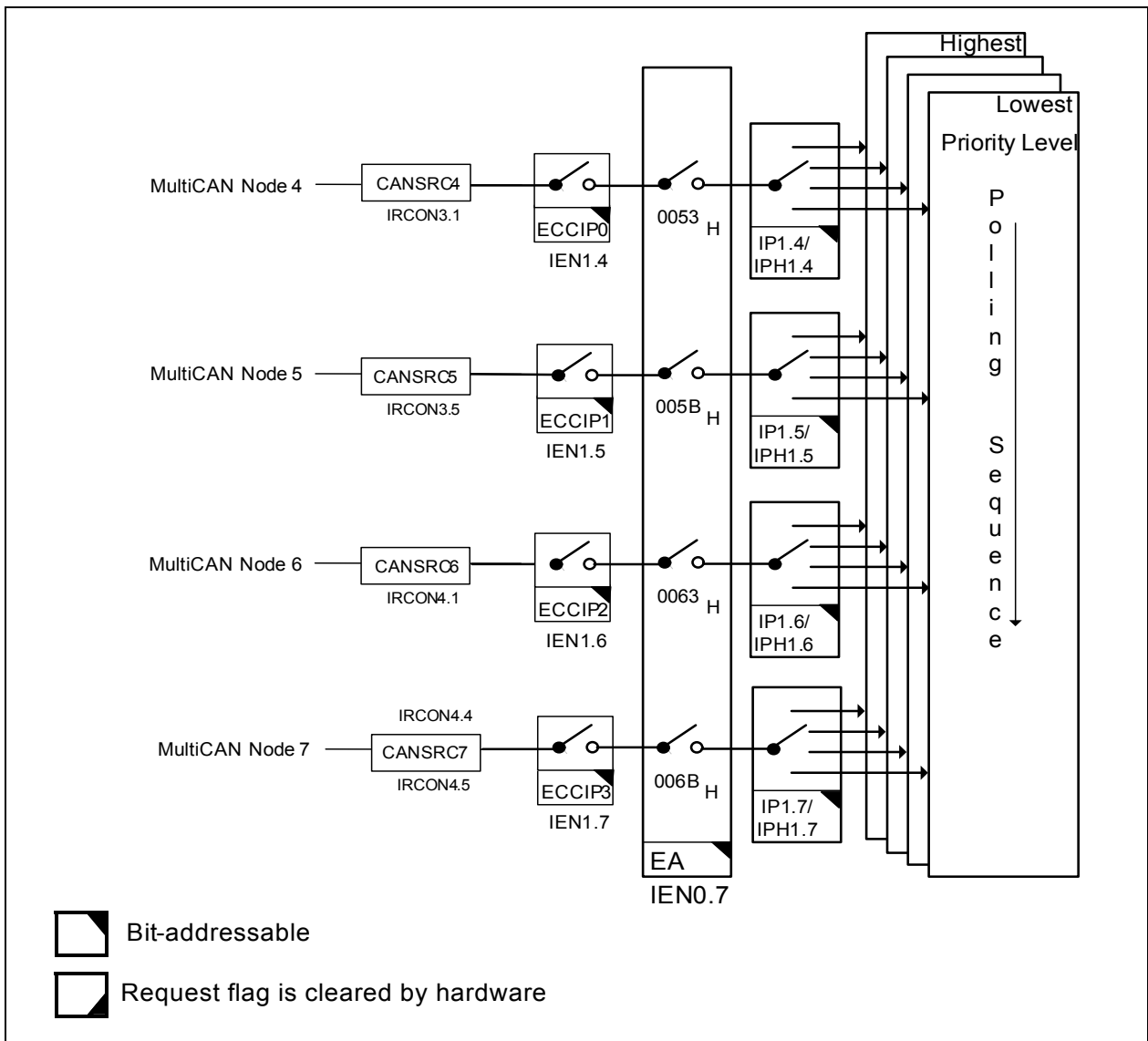

Figure 17 Interrupt Request Sources (Part 5)

### 3.4.2 Interrupt Source and Vector

Each interrupt event source has an associated interrupt vector address for the interrupt node it belongs to. This vector is accessed to service the corresponding interrupt node request. The interrupt service of each interrupt source can be individually enabled or disabled via an enable bit. The assignment of the XC858 interrupt sources to the interrupt vector address and the corresponding interrupt node enable bits are summarized in [Table 17](#).

**Table 17 Interrupt Vector Addresses**

<b>Interrupt Source</b>	<b>Vector Address</b>	<b>Assignment for XC858</b>	<b>Enable Bit</b>	<b>SFR</b>
NMI	0073 <sub>H</sub>	Watchdog Timer NMI	NMIWDT	NMICON
		PLL NMI	NMIPLL	
		Flash Timer NMI	NMIFLASH	
		V <sub>DDP</sub> Prewarning NMI	NMIVDDP	
		Flash ECC NMI	NMIECC	
XINTR0	0003 <sub>H</sub>	External Interrupt 0	EX0	IEN0
XINTR1	000B <sub>H</sub>	Timer 0	ET0	
XINTR2	0013 <sub>H</sub>	External Interrupt 1	EX1	
XINTR3	001B <sub>H</sub>	Timer 1	ET1	
XINTR4	0023 <sub>H</sub>	UART	ES	
XINTR5	002B <sub>H</sub>	T2CCU	ET2	
		UART Fractional Divider (Normal Divider Overflow)		
		MultiCAN Node 0		

**Functional Description**
**Table 17 Interrupt Vector Addresses (cont'd)**

<b>Interrupt Source</b>	<b>Vector Address</b>	<b>Assignment for XC858</b>	<b>Enable Bit</b>	<b>SFR</b>
XINTR6	0033 <sub>H</sub>	MultiCAN Nodes 1 and 2	EADC	IEN1
		ADC[1:0]		
XINTR7	003B <sub>H</sub>	SSC	ESSC	
XINTR8	0043 <sub>H</sub>	External Interrupt 2	EX2	
		T21		
		UART1		
		UART1 Fractional Divider (Normal Divider Overflow)		
XINTR9	004B <sub>H</sub>	External Interrupt 3	EXM	
		External Interrupt 4		
		External Interrupt 5		
		External Interrupt 6		
		T2CCU		
		MultiCAN Node 3		
XINTR10	0053 <sub>H</sub>	MultiCAN Node 4	ECCIP0	
XINTR11	005B <sub>H</sub>	MultiCAN Node 5	ECCIP1	
XINTR12	0063 <sub>H</sub>	MultiCAN Node 6	ECCIP2	
XINTR13	006B <sub>H</sub>	MultiCAN Node 7	ECCIP3	

### 3.4.3 Interrupt Priority

An interrupt that is currently being serviced can only be interrupted by a higher-priority interrupt, but not by another interrupt of the same or lower priority. Hence, an interrupt of the highest priority cannot be interrupted by any other interrupt request.

If two or more requests of different priority levels are received simultaneously, the request of the highest priority is serviced first. If requests of the same priority are received simultaneously, then an internal polling sequence determines which request is serviced first. Thus, within each priority level, there is a second priority structure determined by the polling sequence shown in [Table 18](#).

**Table 18 Priority Structure within Interrupt Level**

Source	Level
Non-Maskable Interrupt (NMI)	(highest)
External Interrupt 0	1
Timer 0 Interrupt	2
External Interrupt 1	3
Timer 1 Interrupt	4
UART Interrupt	5
T2CCU, UART Normal Divider Overflow, MultiCAN Interrupt	6
ADC, MultiCAN Interrupt	7
SSC Interrupt	8
External Interrupt 2, Timer 21, UART1, UART1 Normal Divider Overflow Interrupt	9
External Interrupt [6:3], MultiCAN Interrupt	10
MultiCAN interrupt	11
MultiCAN Interrupt	12
MultiCAN Interrupt	13
MultiCAN Interrupt	14

### **3.5 Parallel Ports**

The XC858 has 40 port pins organized into five parallel ports: Port 0 (P0), Port 1 (P1), Port 3 (P3), Port 4 (P4) and Port 5 (P5). Each pin has a pair of internal pull-up and pull-down devices that can be individually enabled or disabled. These ports are bidirectional and can be used as general purpose input/output (GPIO) or to perform alternate input/output functions for the on-chip peripherals. When configured as an output, the open drain mode can be selected.

#### **Bidirectional Port Features**

- Configurable pin direction
- Configurable pull-up/pull-down devices
- Configurable open drain mode
- Configurable drive strength
- Transfer of data through digital inputs and outputs (general purpose I/O)
- Alternate input/output for on-chip peripherals

Functional Description

Figure 18 shows the structure of a bidirectional port pin.

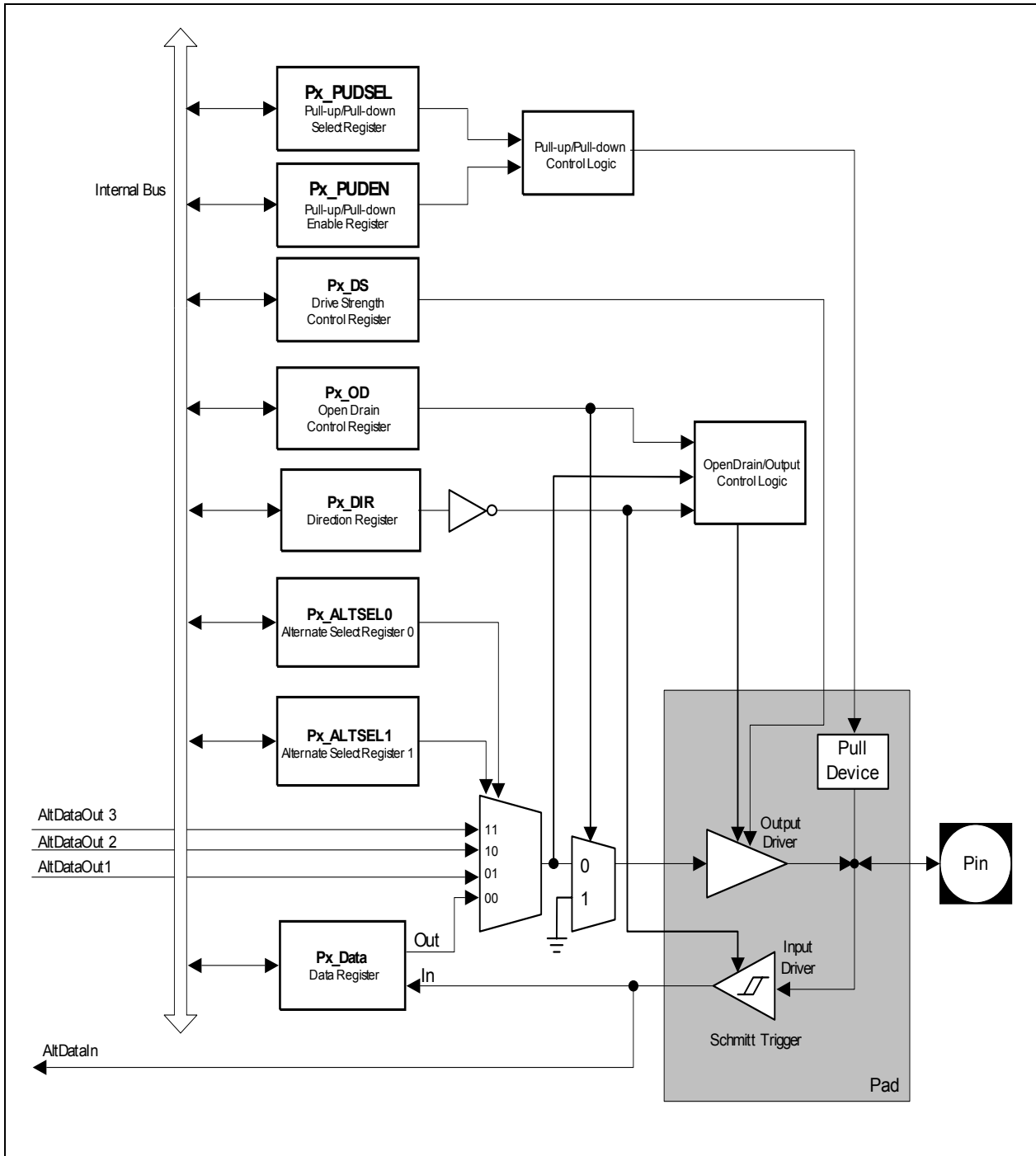

Figure 18 General Structure of Bidirectional Port

### 3.6 Power Supply System with Embedded Voltage Regulator

The XC858 microcontroller requires two different levels of power supply:

- 5.0 V for the Embedded Voltage Regulator (EVR) and Ports
- 2.5 V for the core, memory, on-chip oscillator, and peripherals

**Figure 19** shows the XC858 power supply system. A power supply of 5.0 V must be provided from the external power supply pin. The 2.5 V power supply for the logic is generated by the EVR. The EVR helps to reduce the power consumption of the whole chip and the complexity of the application board design.

The EVR consists of a main voltage regulator and a low power voltage regulator. In active mode, both voltage regulators are enabled. In power-down mode, the main voltage regulator is switched off, while the low power voltage regulator continues to function and provide power supply to the system with low power consumption.

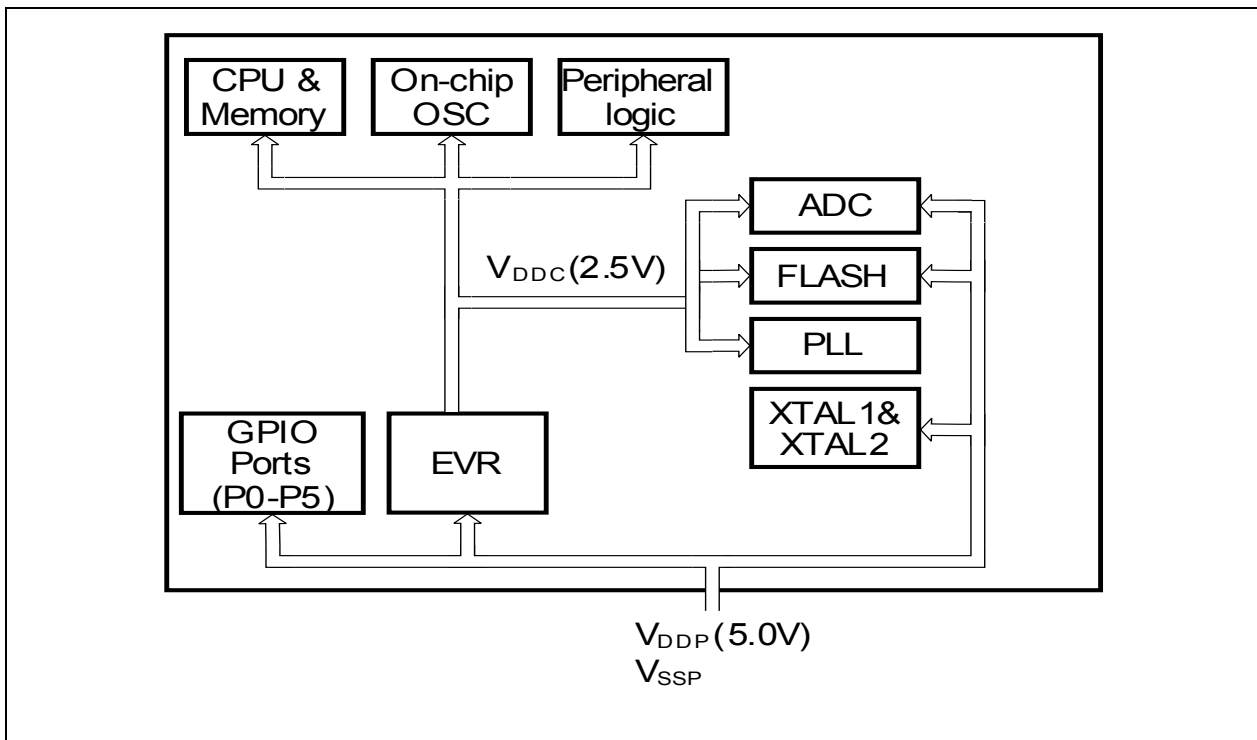

**Figure 19 XC858 Power Supply System**

#### EVR Features

- Input voltage ( $V_{DDP}$ ): 5.0 V
- Output voltage ( $V_{DDC}$ ): 2.5 V  $\pm$  7.5%
- Low power voltage regulator provided in power-down mode
- $V_{DDP}$  prewarning detection
- $V_{DDC}$  brownout detection

### 3.7 Reset Control

The XC858 has five types of reset: power-on reset, hardware reset, watchdog timer reset, power-down wake-up reset, and brownout reset.

When the XC858 is first powered up, the status of certain pins (see [Table 20](#)) must be defined to ensure proper start operation of the device. At the end of a reset sequence, the sampled values are latched to select the desired boot option, which cannot be modified until the next power-on reset or hardware reset. This guarantees stable conditions during the normal operation of the device.

The second type of reset in XC858 is the hardware reset. This reset function can be used during normal operation or when the chip is in power-down mode. A reset input pin RESET is provided for the hardware reset.

The Watchdog Timer (WDT) module is also capable of resetting the device if it detects a malfunction in the system.

Another type of reset that needs to be detected is a reset while the device is in power-down mode (wake-up reset). While the contents of the static RAM are undefined after a power-on reset, they are well defined after a wake-up reset from power-down mode.

#### 3.7.1 Module Reset Behavior

[Table 19](#) lists the functions of the XC858 and the various reset types that affect these functions. The symbol “■” signifies that the particular function is reset to its default state.

**Table 19 Effect of Reset on Device Functions**

Module/ Function	Wake-Up Reset	Watchdog Reset	Hardware Reset	Power-On Reset	Brownout Reset
CPU Core	■	■	■	■	■
Peripherals	■	■	■	■	■
On-Chip Static RAM	Not affected, Reliable	Not affected, Reliable	Not affected, Reliable	Affected, un- reliable	Affected, un- reliable
Oscillator, PLL	■	Not affected	■	■	■
Port Pins	■	■	■	■	■
EVR	The voltage regulator is switched on	Not affected	Not affected	■	■
FLASH	■	■	■	■	■
NMI	Disabled	Disabled	■	■	■

### 3.7.2 Booting Scheme

When the XC858 is reset, it must identify the type of configuration with which to start the different modes once the reset sequence is complete. Thus, boot configuration information that is required for activation of special modes and conditions needs to be applied by the external world through input pins. After power-on reset or hardware reset, the pins MBC, TMS and P0.0 collectively select the different boot options. **Table 20** shows the available boot options in the XC858.

**Table 20 XC858 Boot Selection <sup>1)</sup>**

MBC	TMS	P0.0	Type of Mode	PC Start Value
1	0	X	User Mode <sup>2)</sup> ; on-chip OSC/PLL non-bypassed	0000 <sub>H</sub>
0	0	X	BSL Mode; (UART/ MultiCAN Mode <sup>3)4)</sup> and Alternate BSL Mode <sup>5)</sup> ; on-chip OSC/PLL non-bypassed	0000 <sub>H</sub>
0	1	0	OCDS Mode; on-chip OSC/PLL non-bypassed	0000 <sub>H</sub>
1	1	0	User (JTAG) Mode <sup>6)</sup> ; on-chip OSC/PLL non-bypassed (normal)	0000 <sub>H</sub>

- 1) In addition to the pins MBC, TMS and P0.0, TM pin also requires an external pull down for all the boot options.
- 2) BSL mode is automatically entered if no valid password is installed and data at memory address 0000H equals zero.
- 3) UART or MultiCAN BSL is decoded by firmware based on the protocol for product variant with MultiCAN. If no MultiCAN variant, UART BSL is used.
- 4) In MultiCAN BSL mode, the clock source is switched to XTAL by firmware, bypassing the on-chip oscillator. This avoids any frequency invariance with the on-chip oscillator and allows other frequency clock input, thus ensuring accurate baud rate detection (especially at high bit rates).
- 5) Alternate BSL Mode is a user defined BSL code programmed in Flash. It is entered if the AltBSLPassword is valid.
- 6) Normal user mode with standard JTAG (TCK,TDI,TDO) pins for hot-attach purpose.

*Note: The boot options are valid only with the default set of UART and JTAG pins.*

### **3.8 Clock Generation Unit**

The Clock Generation Unit (CGU) allows great flexibility in the clock generation for the XC858. The power consumption is indirectly proportional to the frequency, whereas the performance of the microcontroller is directly proportional to the frequency. During user program execution, the frequency can be programmed for an optimal ratio between performance and power consumption. Therefore the power consumption can be adapted to the actual application state.

#### **Features**

- Phase-Locked Loop (PLL) for multiplying clock source by different factors
- PLL Base Mode
- Prescaler Mode
- PLL Mode
- Power-down mode support

The CGU consists of an oscillator circuit and a PLL. In the XC858, the oscillator can be from either of these two sources: the on-chip oscillator (4 MHz) or the external oscillator (2 MHz to 20 MHz). The term “oscillator” is used to refer to both on-chip oscillator and external oscillator, unless otherwise stated. After the reset, the on-chip oscillator will be used by default. The external oscillator can be selected via software. In addition, the PLL provides a fail-safe logic to perform oscillator run and loss-of-lock detection. This allows emergency routines to be executed for system recovery or to perform system shut down.

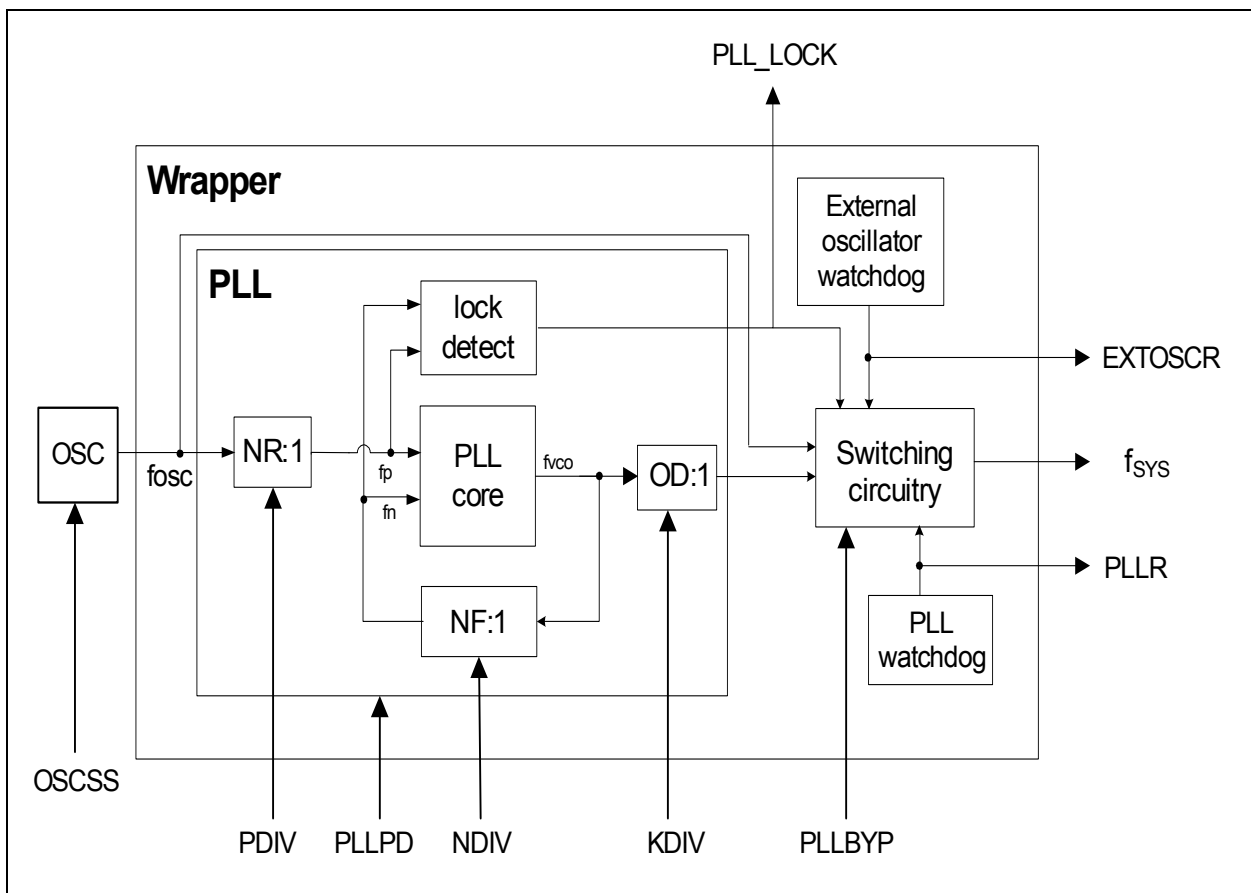

Figure 20 CGU Block Diagram

**Direct Drive (PLL Bypass Operation)**

During PLL bypass operation, the system clock has the same frequency as the external clock source.

$$(3.1)$$

$$f_{\text{SYS}} = f_{\text{OSC}}$$

**PLL Mode**

The CPU clock is derived from the oscillator clock, divided by the NR factor (PDIV), multiplied by the NF factor (NDIV), and divided by the OD factor (KDIV). PLL output must

**Functional Description**

not be bypassed for this PLL mode. The PLL mode is used during normal system operation.

(3.2)

$$f_{\text{SYS}} = f_{\text{OSC}} \times \frac{\text{NF}}{\text{NR} \times \text{OD}}$$

**System Frequency Selection**

For the XC858, the value of NF, NR and OD can be selected by bits NDIV, PDIV and KDIV respectively for different oscillator inputs in order to obtain the required  $f_{\text{sys}}$ . But the combination of these factors must fulfill the following condition:

- $100 \text{ MHz} < f_{\text{VCO}} < 175 \text{ MHz}$
- $800 \text{ kHz} < f_{\text{OSC}} / (2 * \text{NR}) < 8 \text{ MHz}$

**Table 21** provides examples on how the typical system frequency of  $f_{\text{sys}} = 144 \text{ MHz}$  and maximum frequency of  $160 \text{ MHz}$  (CPU clock =  $24 \text{ MHz}$ ) can be obtained for the different oscillator sources.

**Table 21 System frequency ( $f_{\text{sys}} = 144 \text{ MHz}$ )**

Oscillator	fosc	N	P	K	f <sub>sys</sub>
On-chip	4 MHz	72	2	1	144 MHz
	4 MHz	80	2	1	160 MHz
External	8 MHz	72	4	1	144 MHz
	6 MHz	72	3	1	144 MHz
	4 MHz	72	2	1	144 MHz

**3.8.1 Recommended External Oscillator Circuits**

The oscillator circuit, a Pierce oscillator, is designed to work with both, an external crystal oscillator or an external stable clock source. It basically consists of an inverting amplifier and a feedback element with XTAL1 as input, and XTAL2 as output.

When using a crystal, a proper external oscillator circuitry must be connected to both pins, XTAL1 and XTAL2. The crystal frequency can be within the range of  $2 \text{ MHz}$  to  $20 \text{ MHz}$ . Additionally, it is necessary to have two load capacitances  $C_{X1}$  and  $C_{X2}$ , and depending on the crystal type, a series resistor  $R_{X2}$ , to limit the current. A test resistor  $R_Q$  may be temporarily inserted to measure the oscillation allowance (negative resistance) of the oscillator circuitry.  $R_Q$  values are typically specified by the crystal vendor. An external feedback resistor  $R_f$  is also required in the external oscillator circuitry. The exact values and related operating range are dependent on the crystal frequency and have to be determined and optimized together with the crystal vendor using the negative

**Functional Description**

resistance method. Oscillation measurement with the final target system is strongly recommended to verify the input amplitude at XTAL1 and to determine the actual oscillation allowance (margin negative resistance) for the oscillator-crystal system.

When using an external clock signal, the signal must be connected to XTAL1. XTAL2 is left open (unconnected).

The oscillator can also be used in combination with a ceramic resonator. The final circuitry must also be verified by the resonator vendor. **Figure 21** shows the recommended external oscillator circuitries for both operating modes, external crystal mode and external input clock mode.

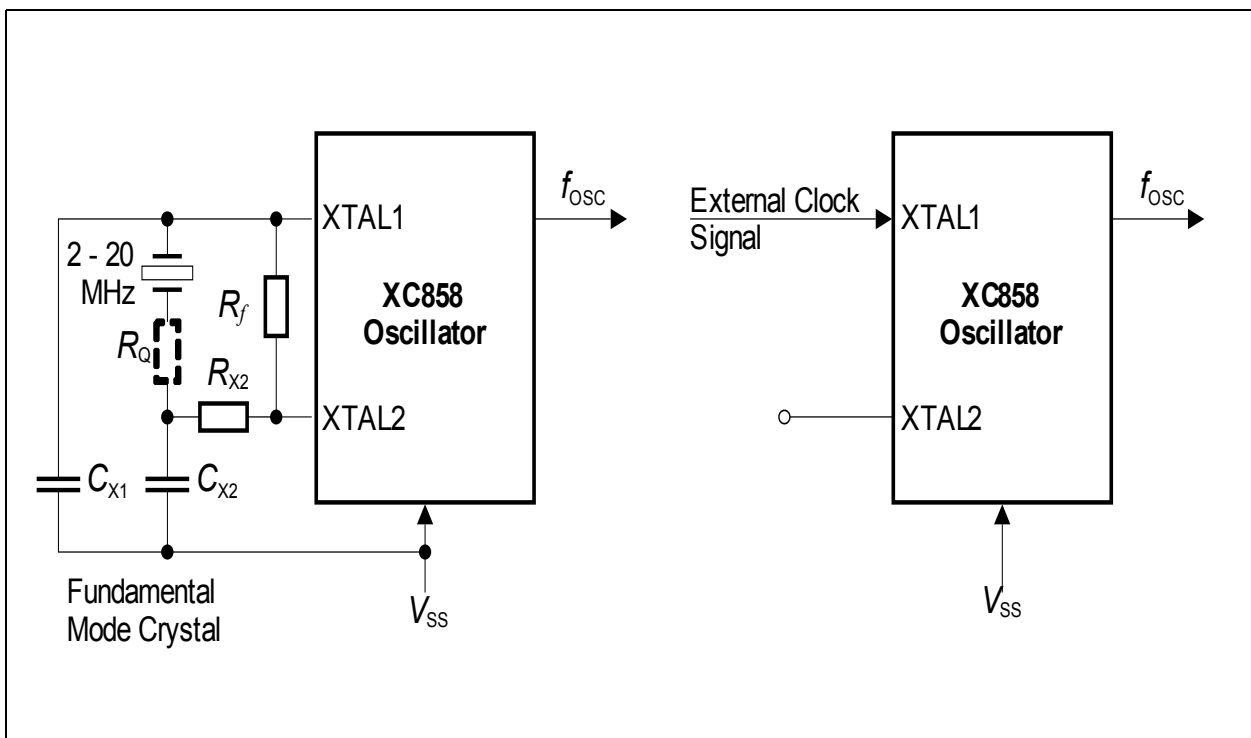

**Figure 21 External Oscillator Circuitry**

*Note: For crystal operation, it is strongly recommended to measure the negative resistance in the final target system (layout) to determine the optimum parameters for the oscillator operation. Please refer to the minimum and maximum values of the negative resistance specified by the crystal supplier.*

### 3.8.2 Clock Management

The CGU generates all clock signals required within the microcontroller from a single clock,  $f_{sys}$ . During normal system operation, the typical frequencies of the different modules are as follow:

- CPU clock: CCLK, SCLK = 24 MHz
- MultiCAN clock : MCANCLK = 24 or 48 MHz
- T2CCU clock : T2CCUCLK = 24 or 48 MHz
- Peripheral clock: PCLK = 24 MHz

In addition, different clock frequencies can be output to pin CLKOUT (P0.0 or P0.7). The clock output frequency, which is derived from the clock output divider (bit COREL), can further be divided by 2 using toggle latch (bit TLEN is set to 1). The resulting output frequency has a 50% duty cycle. **Figure 22** shows the clock distribution of the XC858.

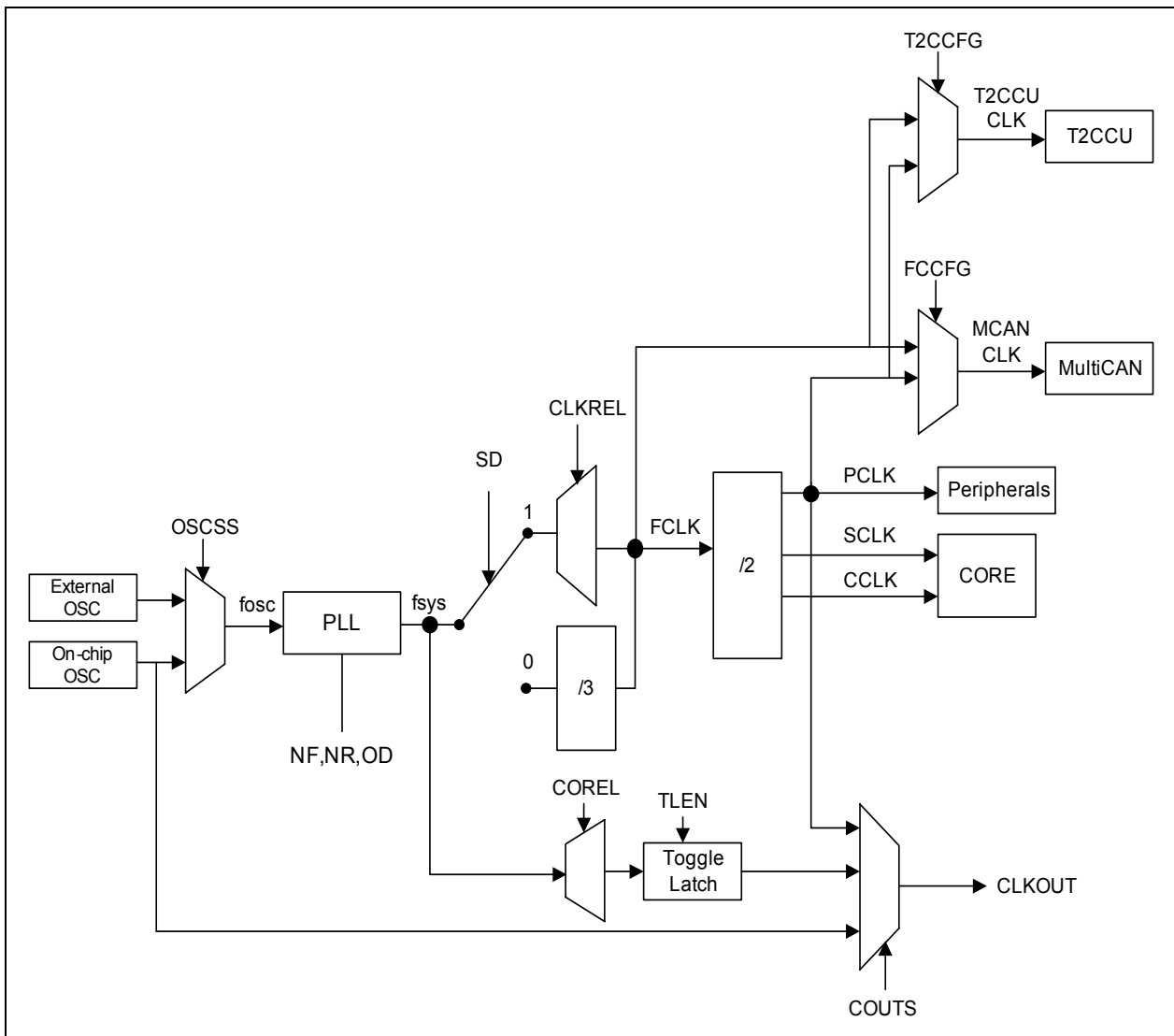

**Figure 22** Clock Generation from  $f_{sys}$

---

**Functional Description**

For power saving purposes, the clocks may be disabled or slowed down according to [Table 22](#).

**Table 22** System frequency ( $f_{\text{sys}} = 144 \text{ MHz}$ )

<b>Power Saving Mode</b>	<b>Action</b>
Idle	Clock to the CPU is disabled.
Slow-down	Clocks to the CPU and all the peripherals are divided by a common programmable factor defined by bit field CMCON.CLKREL.
Power-down	Oscillator and PLL are switched off.

### 3.9 Power Saving Modes

The power saving modes of the XC858 provide flexible power consumption through a combination of techniques, including:

- Stopping the CPU clock
- Stopping the clocks of individual system components
- Reducing clock speed of some peripheral components
- Power-down of the entire system with fast restart capability

After a reset, the active mode (normal operating mode) is selected by default (see [Figure 23](#)) and the system runs in the main system clock frequency. From active mode, different power saving modes can be selected by software. They are:

- Idle mode
- Slow-down mode
- Power-down mode

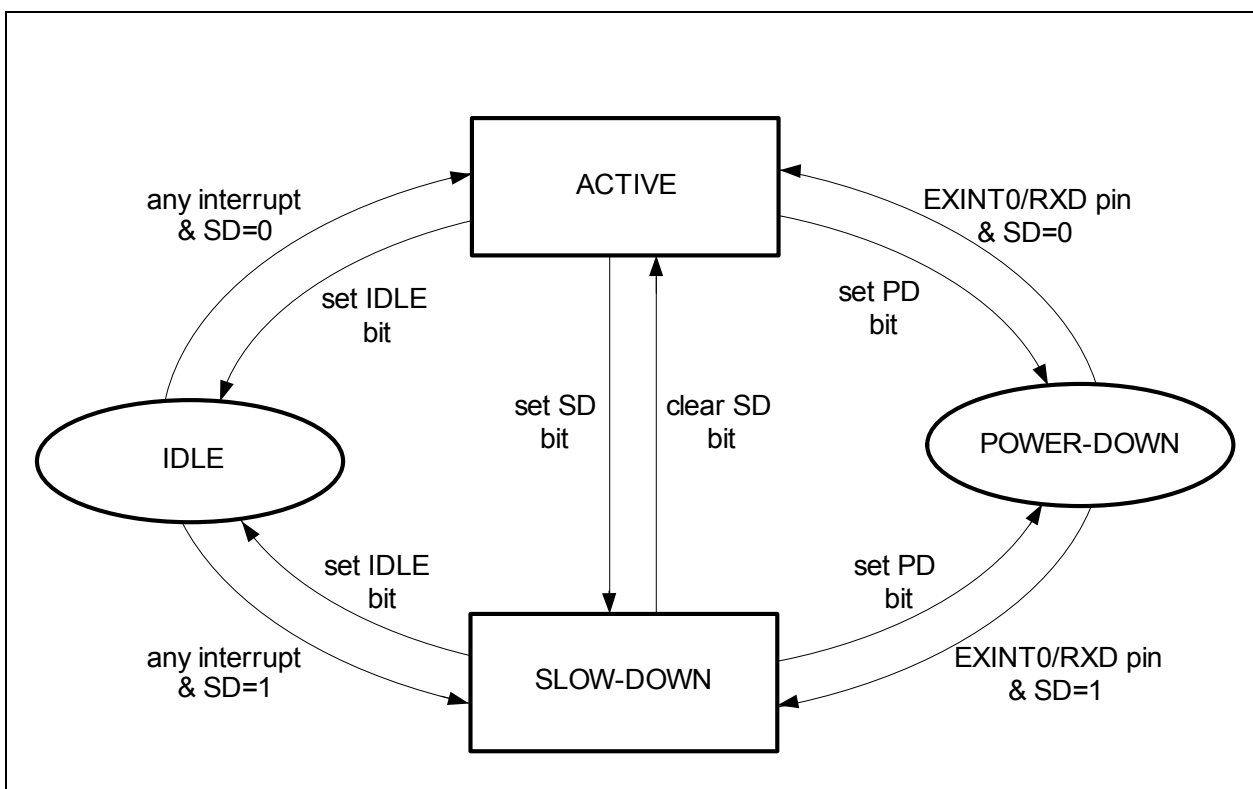

Figure 23 Transition between Power Saving Modes

### 3.10 Watchdog Timer

The Watchdog Timer (WDT) provides a highly reliable and secure way to detect and recover from software or hardware failures. The WDT is reset at a regular interval that is predefined by the user. The CPU must service the WDT within this interval to prevent the WDT from causing an XC858 system reset. Hence, routine service of the WDT confirms that the system is functioning properly. This ensures that an accidental malfunction of the XC858 will be aborted in a user-specified time period.

In debug mode, the WDT is default suspended and stops counting. Therefore, there is no need to refresh the WDT during debugging.

#### Features

- 16-bit Watchdog Timer
- Programmable reload value for upper 8 bits of timer
- Programmable window boundary
- Selectable input frequency of  $f_{PCLK}/2$  or  $f_{PCLK}/128$
- Time-out detection with NMI generation and reset prewarning activation (after which a system reset will be performed)

The WDT is a 16-bit timer incremented by a count rate of  $f_{PCLK}/2$  or  $f_{PCLK}/128$ . This 16-bit timer is realized as two concatenated 8-bit timers. The upper 8 bits of the WDT can be preset to a user-programmable value via a watchdog service access in order to modify the watchdog expire time period. The lower 8 bits are reset on each service access.

Figure 24 shows the block diagram of the WDT unit.

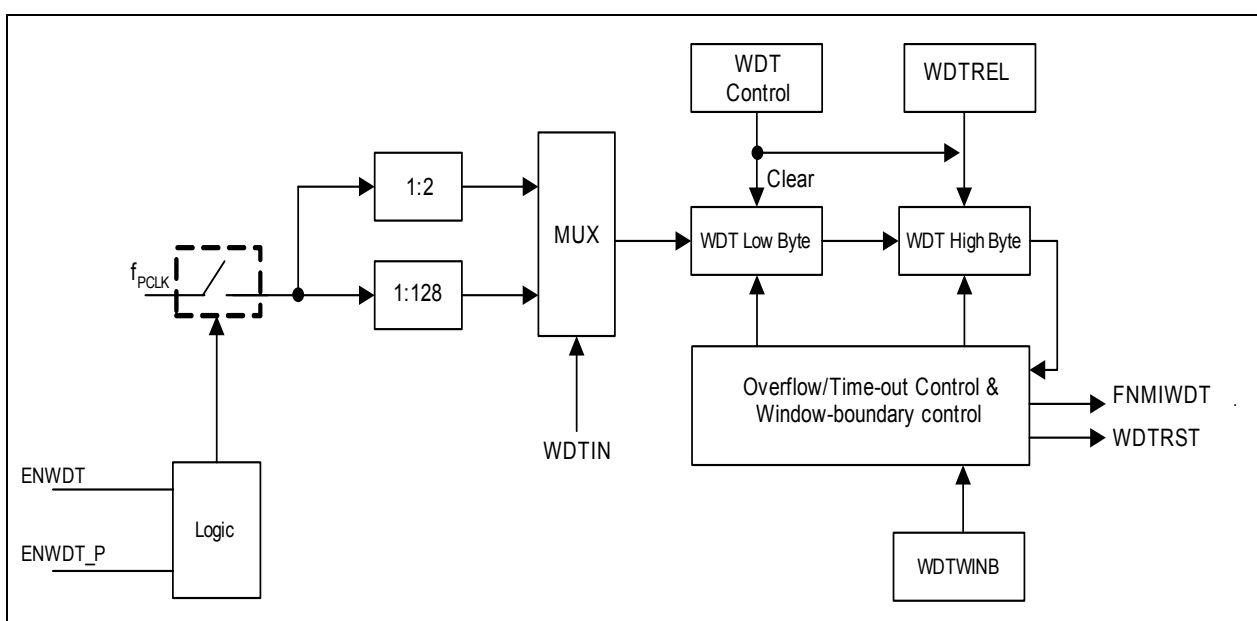

Figure 24 WDT Block Diagram

---

**Functional Description**

If the WDT is not serviced before the timer overflow, a system malfunction is assumed. As a result, the WDT NMI is triggered (assert FNMIWDT) and the reset prewarning is entered. The prewarning period lasts for 30<sub>H</sub> count, after which the system is reset (assert WDTRST).

The WDT has a “programmable window boundary” which disallows any refresh during the WDT’s count-up. A refresh during this window boundary constitutes an invalid access to the WDT, causing the reset prewarning to be entered but without triggering the WDT NMI. The system will still be reset after the prewarning period is over. The window boundary is from 0000<sub>H</sub> to the value obtained from the concatenation of WDTWINB and 00<sub>H</sub>.

After being serviced, the WDT continues counting up from the value (<WDTREL> \* 2<sup>8</sup>). The time period for an overflow of the WDT is programmable in two ways:

- The input frequency to the WDT can be selected to be either  $f_{PCLK}/2$  or  $f_{PCLK}/128$
- The reload value WDTREL for the high byte of WDT can be programmed in register WDTREL

The period,  $P_{WDT}$ , between servicing the WDT and the next overflow can be determined by the following formula:

$$P_{WDT} = \frac{2^{(1 + WDTIN \times 6)} \times (2^{16} - WDTREL \times 2^8)}{f_{PCLK}} \quad (3.3)$$

If the Window-Boundary Refresh feature of the WDT is enabled, the period  $P_{WDT}$  between servicing the WDT and the next overflow is shortened if WDTWINB is greater than WDTREL, see [Figure 25](#). This period can be calculated using the same formula by replacing WDTREL with WDTWINB. For this feature to be useful, WDTWINB cannot be smaller than WDTREL.

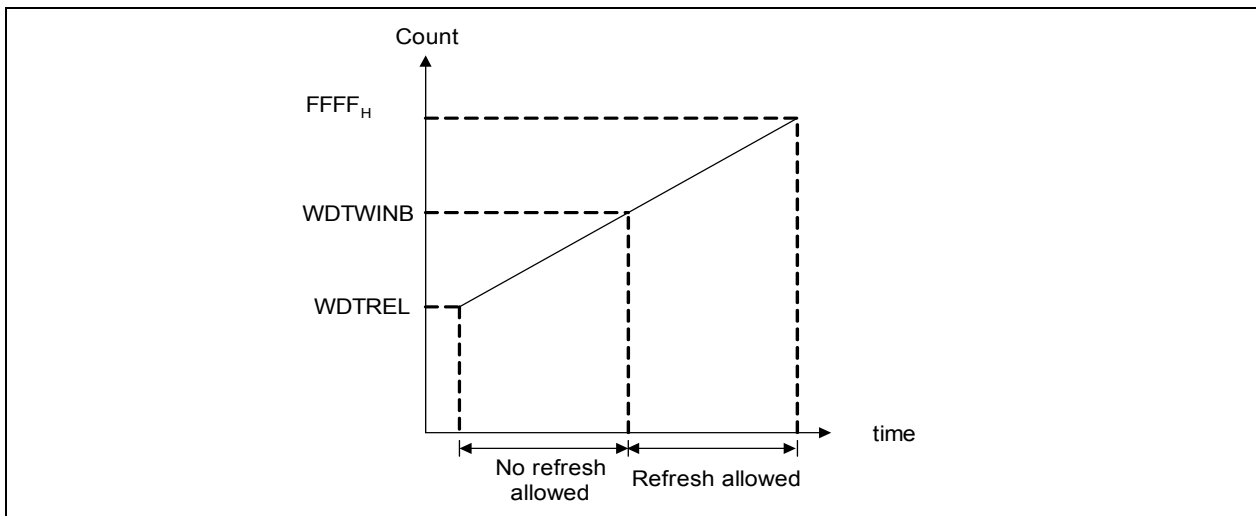

**Figure 25 WDT Timing Diagram**

**Table 23** lists the possible watchdog time ranges that can be achieved using a certain module clock. Some numbers are rounded to 3 significant digits.

**Table 23 Watchdog Time Ranges**

Reload value In WDTREL	Prescaler for $f_{PCLK}$	
	2 (WDTIN = 0)	128 (WDTIN = 1)
	24 MHz	24 MHz
FF <sub>H</sub>	21.3 $\mu$ s	1.37 ms
7F <sub>H</sub>	2.75 ms	176 ms
00 <sub>H</sub>	5.46 ms	350 ms

### 3.11 UART and UART1

The XC858 provides two Universal Asynchronous Receiver/Transmitter (UART and UART1) modules for full-duplex asynchronous reception/transmission. Both are also receive-buffered, i.e., they can commence reception of a second byte before a previously received byte has been read from the receive register. However, if the first byte still has not been read by the time reception of the second byte is complete, one of the bytes will be lost.

#### Features

- Full-duplex asynchronous modes
  - 8-bit or 9-bit data frames, LSB first
  - Fixed or variable baud rate
- Receive buffered
- Multiprocessor communication

**Functional Description**

- Interrupt generation on the completion of a data transmission or reception
- The UART modules can operate in the four modes shown in [Table 24](#).

**Table 24     UART Modes**

Operating Mode	Baud Rate
Mode 0: 8-bit shift register	$f_{PCLK}/2$
Mode 1: 8-bit shift UART	Variable
Mode 2: 9-bit shift UART	$f_{PCLK}/32$ or $f_{PCLK}/64$ <sup>1)</sup>
Mode 3: 9-bit shift UART	Variable

1) For UART1 module, the baud rate is fixed at  $f_{PCLK}/64$ .

There are several ways to generate the baud rate clock for the serial port, depending on the mode in which it is operating. In mode 0, the baud rate for the transfer is fixed at  $f_{PCLK}/2$ . In mode 2, the baud rate is generated internally based on the UART input clock and can be configured to either  $f_{PCLK}/32$  or  $f_{PCLK}/64$ . For UART1 module, only  $f_{PCLK}/64$  is available. The variable baud rate is set by the underflow rate on the dedicated baud-rate generator. For UART module, the variable baud rate alternatively can be set by the overflow rate on Timer 1.

### 3.11.1     Baud-Rate Generator

Both UART modules have their own dedicated baud-rate generator, which is based on a programmable 8-bit reload value, and includes divider stages (i.e., prescaler and fractional divider) for generating a wide range of baud rates based on its input clock  $f_{PCLK}$ , see [Figure 26](#).

Functional Description

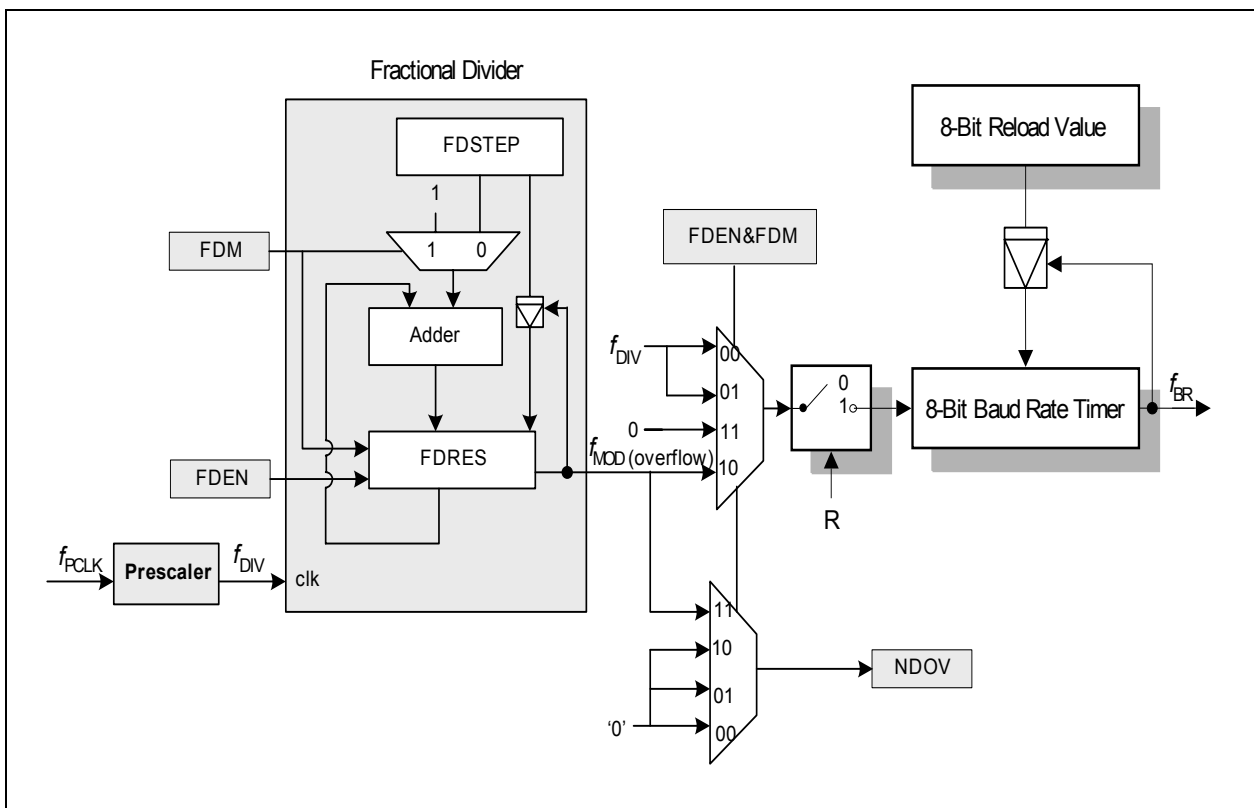

**Figure 26 Baud-rate Generator Circuitry**

The baud rate timer is a count-down timer and is clocked by either the output of the fractional divider ( $f_{MOD}$ ) if the fractional divider is enabled (FDCON.FDEN = 1), or the output of the prescaler ( $f_{DIV}$ ) if the fractional divider is disabled (FDEN = 0). For baud rate generation, the fractional divider must be configured to fractional divider mode (FDCON.FDM = 0). This allows the baud rate control run bit BCON.R to be used to start or stop the baud rate timer. At each timer underflow, the timer is reloaded with the 8-bit reload value in register BG and one clock pulse is generated for the serial channel.

Enabling the fractional divider in normal divider mode (FDEN = 1 and FDM = 1) stops the baud rate timer and nullifies the effect of bit BCON.R. See [Section 3.12](#).

The baud rate ( $f_{BR}$ ) value is dependent on the following parameters:

- Input clock  $f_{PCLK}$
- Prescaling factor ( $2^{BRPRE}$ ) defined by bit field BRPRE in register BCON
- Fractional divider (STEP/256) defined by register FDSTEP  
(to be considered only if fractional divider is enabled and operating in fractional divider mode)
- 8-bit reload value (BR\_VALUE) for the baud rate timer defined by register BG

**Functional Description**

The following formulas calculate the final baud rate without and with the fractional divider respectively:

$$\text{baud rate} = \frac{f_{\text{PCLK}}}{16 \times 2^{\text{BRPRE}} \times (\text{BR\_VALUE} + 1)} \quad \text{where } 2^{\text{BRPRE}} \times (\text{BR\_VALUE} + 1) > 1$$

(3.4)

$$\text{baud rate} = \frac{f_{\text{PCLK}}}{16 \times 2^{\text{BRPRE}} \times (\text{BR\_VALUE} + 1)} \times \frac{\text{STEP}}{256}$$

(3.5)

The maximum baud rate that can be generated is limited to  $f_{\text{PCLK}}/32$ . Hence, for a module clock of 24 MHz, the maximum achievable baud rate is 0.75 MBaud.

**Table 25** lists the various commonly used baud rates with their corresponding parameter settings and deviation errors. The fractional divider is disabled and a module clock of 24 MHz is used.

**Table 25 Typical Baud rates for UART with Fractional Divider disabled**

Baud rate	Prescaling Factor (2BRPRE)	Reload Value (BR_VALUE + 1)	Deviation Error
19.2 kBaud	1 (BRPRE=000 <sub>B</sub> )	78 (4E <sub>H</sub> )	0.17 %
9600 Baud	1 (BRPRE=000 <sub>B</sub> )	156 (9C <sub>H</sub> )	0.17 %
4800 Baud	2 (BRPRE=001 <sub>B</sub> )	156 (9C <sub>H</sub> )	0.17 %
2400 Baud	4 (BRPRE=010 <sub>B</sub> )	156 (9C <sub>H</sub> )	0.17 %

The fractional divider allows baud rates of higher accuracy (lower deviation error) to be generated. **Table 26** lists the resulting deviation errors from generating a baud rate of 57.6 kHz, using different module clock frequencies. The fractional divider is enabled (fractional divider mode) and the corresponding parameter settings are shown.

**Table 26 Deviation Error for UART with Fractional Divider enabled**

$f_{PCLK}$	Prescaling Factor (2BRPRE)	Reload Value (BR_VALUE + 1)	STEP	Deviation Error
24 MHz	1	6 (6 <sub>H</sub> )	59 (3B <sub>H</sub> )	+0.03 %
12 MHz	1	3 (3 <sub>H</sub> )	59 (3B <sub>H</sub> )	+0.03 %
8 MHz	1	2 (2 <sub>H</sub> )	59 (3B <sub>H</sub> )	+0.03 %
6 MHz	1	6 (6 <sub>H</sub> )	236 (EC <sub>H</sub> )	+0.03 %

### 3.11.2 Baud Rate Generation using Timer 1

In UART modes 1 and 3 of UART module, Timer 1 can be used for generating the variable baud rates. In theory, this timer could be used in any of its modes. But in practice, it should be set into auto-reload mode (Timer 1 mode 2), with its high byte set to the appropriate value for the required baud rate. The baud rate is determined by the Timer 1 overflow rate and the value of SMOD as follows:

$$\text{Mode 1, 3 baud rate} = \frac{2^{\text{SMOD}} \times f_{PCLK}}{32 \times 2 \times (256 - \text{TH1})} \quad (3.6)$$

### 3.12 Normal Divider Mode (8-bit Auto-reload Timer)

Setting bit FDM in register FDCON to 1 configures the fractional divider to normal divider mode, while at the same time disables baud rate generation (see [Figure 26](#)). Once the fractional divider is enabled (FDEN = 1), it functions as an 8-bit auto-reload timer (with no relation to baud rate generation) and counts up from the reload value with each input clock pulse. Bit field RESULT in register FDRES represents the timer value, while bit field STEP in register FDSTEP defines the reload value. At each timer overflow, an overflow flag (FDCON.NDOV) will be set and an interrupt request generated. This gives an output clock  $f_{MOD}$  that is 1/n of the input clock  $f_{DIV}$ , where n is defined by 256 - STEP. The output frequency in normal divider mode is derived as follows:

$$f_{MOD} = f_{DIV} \times \frac{1}{256 - \text{STEP}} \quad (3.7)$$

### 3.13 High-Speed Synchronous Serial Interface

The High-Speed Synchronous Serial Interface (SSC) supports full-duplex and half-duplex synchronous communication. The serial clock signal can be generated by the SSC internally (master mode), using its own 16-bit baud-rate generator, or can be received from an external master (slave mode). Data width, shift direction, clock polarity and phase are programmable. This allows communication with SPI-compatible devices or devices using other synchronous serial interfaces.

#### Features

- Master and slave mode operation
  - Full-duplex or half-duplex operation
- Transmit and receive buffered
- Flexible data format
  - Programmable number of data bits: 2 to 8 bits
  - Programmable shift direction: LSB or MSB shift first
  - Programmable clock polarity: idle low or high state for the shift clock
  - Programmable clock/data phase: data shift with leading or trailing edge of the shift clock
- Variable baud rate
- Compatible with Serial Peripheral Interface (SPI)
- Interrupt generation
  - On a transmitter empty condition
  - On a receiver full condition
  - On an error condition (receive, phase, baud rate, transmit error)

Data is transmitted or received on lines TXD and RXD, which are normally connected to the pins MTSR (Master Transmit/Slave Receive) and MRST (Master Receive/Slave Transmit). The clock signal is output via line MS\_CLK (Master Serial Shift Clock) or input via line SS\_CLK (Slave Serial Shift Clock). Both lines are normally connected to the pin SCLK. Transmission and reception of data are double-buffered.

**Figure 27** shows the block diagram of the SSC.

Functional Description

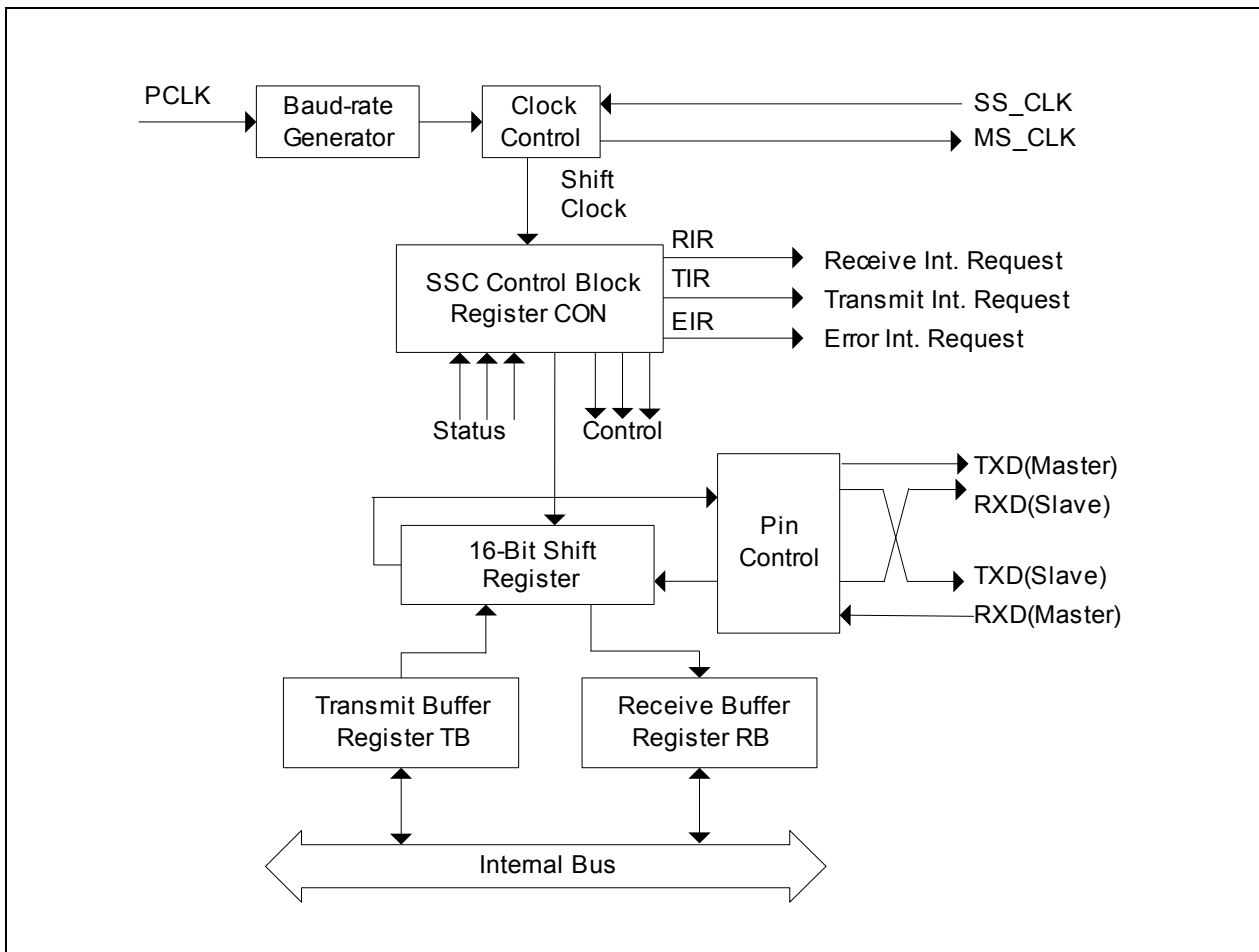

Figure 27 SSC Block Diagram

### 3.14 Timer 0 and Timer 1

Timer 0 and Timer 1 can function as both timers or counters. When functioning as a timer, Timer 0 and Timer 1 are incremented every machine cycle, i.e. every 2 input clocks (or 2 PCLKs). When functioning as a counter, Timer 0 and Timer 1 are incremented in response to a 1-to-0 transition (falling edge) at their respective external input pins, T0 or T1.

Timer 0 and 1 are fully compatible and can be configured in four different operating modes for use in a variety of applications, see [Table 27](#). In modes 0, 1 and 2, the two timers operate independently, but in mode 3, their functions are specialized.

**Table 27 Timer 0 and Timer 1 Modes**

Mode	Operation
<b>0</b>	<b>13-bit timer</b> The timer is essentially an 8-bit counter with a divide-by-32 prescaler. This mode is included solely for compatibility with Intel 8048 devices.
<b>1</b>	<b>16-bit timer</b> The timer registers, TLx and THx, are concatenated to form a 16-bit counter.
<b>2</b>	<b>8-bit timer with auto-reload</b> The timer register TLx is reloaded with a user-defined 8-bit value in THx upon overflow.
<b>3</b>	<b>Timer 0 operates as two 8-bit timers</b> The timer registers, TL0 and TH0, operate as two separate 8-bit counters. Timer 1 is halted and retains its count even if enabled.

### 3.15 Timer 2 and Timer 21

Timer 2 and Timer 21 are 16-bit general purpose timers (THL2) that are fully compatible and have two modes of operation, a 16-bit auto-reload mode and a 16-bit one channel capture mode, see [Table 28](#). As a timer, the timers count with an input clock of PCLK/12 (if prescaler is disabled). As a counter, they count 1-to-0 transitions on pin T2. In the counter mode, the maximum resolution for the count is PCLK/24 (if prescaler is disabled).

**Table 28 Timer 2 Modes**

Mode	Description
<b>Auto-reload</b>	<b>Up/Down Count Disabled</b> <ul style="list-style-type: none"> <li>• Count up only</li> <li>• Start counting from 16-bit reload value, overflow at FFFF<sub>H</sub></li> <li>• Reload event configurable for trigger by overflow condition only, or by negative/positive edge at input pin T2EX as well</li> <li>• Programmable reload value in register RC2</li> <li>• Interrupt is generated with reload event</li> </ul>
	<b>Up/Down Count Enabled</b> <ul style="list-style-type: none"> <li>• Count up or down, direction determined by level at input pin T2EX</li> <li>• No interrupt is generated</li> <li>• Count up               <ul style="list-style-type: none"> <li>– Start counting from 16-bit reload value, overflow at FFFF<sub>H</sub></li> <li>– Reload event triggered by overflow condition</li> <li>– Programmable reload value in register RC2</li> </ul> </li> <li>• Count down               <ul style="list-style-type: none"> <li>– Start counting from FFFF<sub>H</sub>, underflow at value defined in register RC2</li> <li>– Reload event triggered by underflow condition</li> <li>– Reload value fixed at FFFF<sub>H</sub></li> </ul> </li> </ul>
<b>Channel capture</b>	<ul style="list-style-type: none"> <li>• Count up only</li> <li>• Start counting from 0000<sub>H</sub>, overflow at FFFF<sub>H</sub></li> <li>• Reload event triggered by overflow condition</li> <li>• Reload value fixed at 0000<sub>H</sub></li> <li>• Capture event triggered by falling/rising edge at pin T2EX</li> <li>• Captured timer value stored in register RC2</li> <li>• Interrupt is generated with reload or capture event</li> </ul>

### 3.16 Timer 2 Capture/Compare Unit

The T2CCU (Timer 2 Capture/Compare Unit) consists of the standard Timer 2 unit and a Capture/compare unit (CCU). The Capture/Compare Timer (CCT) is part of the CCU. Control is available in the T2CCU to select individually for each of its 16-bit capture/compare channel, either the Timer 2 or the Capture/Compare Timer (CCT) as the time base. Both timers have a resolution of 16 bits. The clock frequency of T2CCU,  $f_{T2CCU}$ , could be set at PCLK frequency or 2 times the PCLK frequency.

The T2CCU can be used for various digital signal generation and event capturing like pulse generation, pulse width modulation, pulse width measuring etc. Target applications include various automotive control as well as industrial (frequency generation, digital-to-analog conversion, process control etc.).

#### T2CCU Features

- Option to select individually for each channel, either Timer 2 or Capture/Compare Timer as time base
- Extremely flexible Capture/Compare Timer count rate by cascading with Timer 2
- Capture/Compare Timer may be 'reset' immediately by triggering overflow event
- 16-bit resolution
- Six compare channels in total
- Four capture channels multiplexed with the compare channels, in total
- Shadow register for each compare register
  - Transfer via software control or on timer overflow.
- Compare Mode 0: Compare output signal changes from the inactive level to active level on compare match. Returns to inactive level on timer overflow.
  - Active level can be defined by register bit for channel groups A and B.
  - Support of 0% to 100% duty cycle in compare mode 0.
- Compare Mode 1: Full control of the software on the compare output signal level, for the next compare match.
- Concurrent Compare Mode with channel 0
- Capture Mode 0: Capture on any external event (rising/falling/both edge) at the 4 pins T2CC0 to T2CC3.
- Capture Mode 1: Capture upon writing to the low byte of the corresponding channel capture register.
- Capture mode 0 or 1 can be established independently on the 4 capture channels.

Functional Description

3.17 Controller Area Network (MultiCAN)

The MultiCAN module contains two Full-CAN nodes operating independently or exchanging data and remote frames via a gateway function. Transmission and reception of CAN frames is handled in accordance to CAN specification V2.0 B active. Each CAN node can receive and transmit standard frames with 11-bit identifiers as well as extended frames with 29-bit identifiers.

Both CAN nodes share a common set of message objects, where each message object may be individually allocated to one of the CAN nodes. Besides serving as a storage container for incoming and outgoing frames, message objects may be combined to build gateways between the CAN nodes or to setup a FIFO buffer.

The message objects are organized in double chained lists, where each CAN node has it's own list of message objects. A CAN node stores frames only into message objects that are allocated to the list of the CAN node. It only transmits messages from objects of this list. A powerful, command driven list controller performs all list operations.

The bit timings for the CAN nodes are derived from the peripheral clock ( $f_{CAN}$ ) and are programmable up to a data rate of 1 Mbaud. A pair of receive and transmit pins connects each CAN node to a bus transceiver.

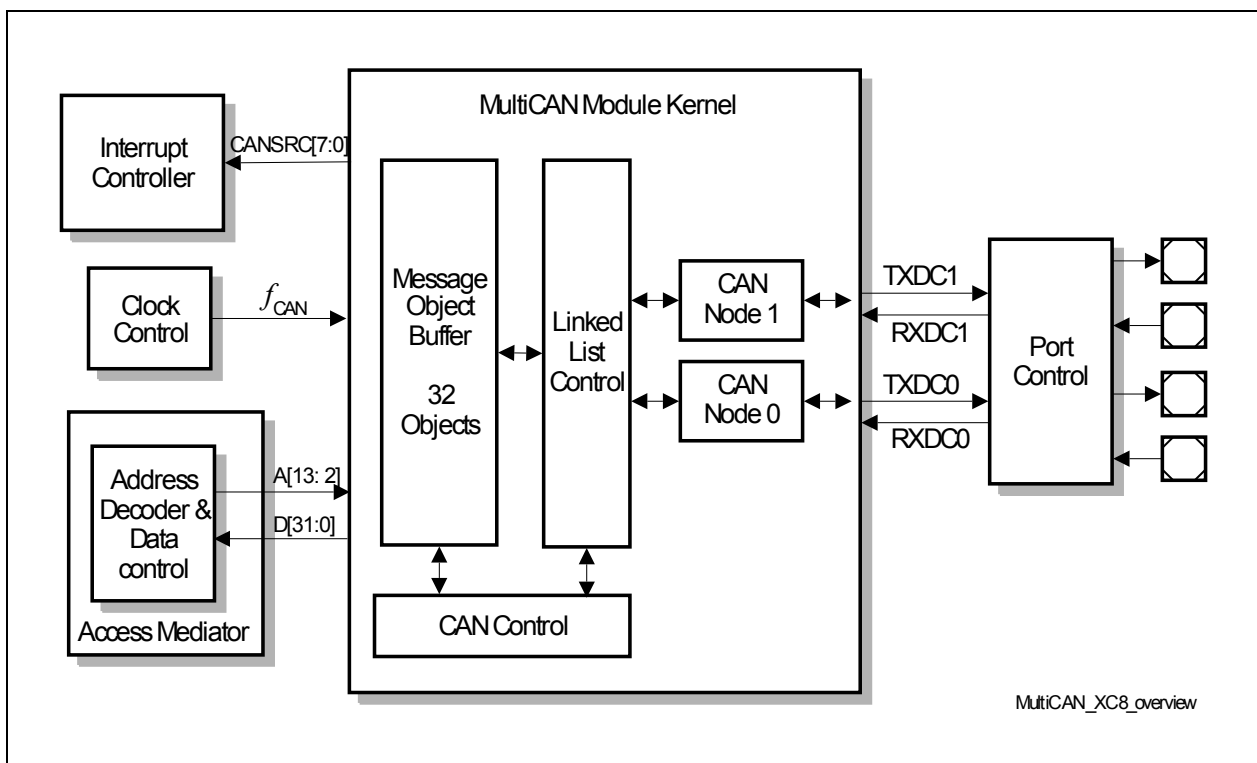

Figure 28 Overview of the MultiCAN

Features

- Compliant to ISO 11898.

---

## Functional Description

- CAN functionality according to CAN specification V2.0 B active.
- Dedicated control registers are provided for each CAN node.
- A data transfer rate up to 1 MBaud is supported.
- Flexible and powerful message transfer control and error handling capabilities are implemented.
- Advanced CAN bus bit timing analysis and baud rate detection can be performed for each CAN node via the frame counter.
- Full-CAN functionality: A set of 32 message objects can be individually
  - allocated (assigned) to any CAN node
  - configured as transmit or receive object
  - setup to handle frames with 11-bit or 29-bit identifier
  - counted or assigned a timestamp via a frame counter
  - configured to remote monitoring mode
- Advanced Acceptance Filtering:
  - Each message object provides an individual acceptance mask to filter incoming frames.
  - A message object can be configured to accept only standard or only extended frames or to accept both standard and extended frames.
  - Message objects can be grouped into 4 priority classes.
  - The selection of the message to be transmitted first can be performed on the basis of frame identifier, IDE bit and RTR bit according to CAN arbitration rules.
- Advanced Message Object Functionality:
  - Message Objects can be combined to build FIFO message buffers of arbitrary size, which is only limited by the total number of message objects.
  - Message objects can be linked to form a gateway to automatically transfer frames between 2 different CAN buses. A single gateway can link any two CAN nodes. An arbitrary number of gateways may be defined.
- Advanced Data Management:
  - The Message objects are organized in double chained lists.
  - List reorganizations may be performed any time, even during full operation of the CAN nodes.
  - A powerful, command driven list controller manages the organization of the list structure and ensures consistency of the list.
  - Message FIFOs are based on the list structure and can easily be scaled in size during CAN operation.
  - Static Allocation Commands offer compatibility with TwinCAN applications, which are not list based.
- Advanced Interrupt Handling:
  - Up to 8 interrupt output lines are available. Most interrupt requests can be individually routed to one of the 8 interrupt output lines.
  - Message postprocessing notifications can be flexibly aggregated into a dedicated register field of 64 notification bits.

### 3.18 Analog-to-Digital Converter

The XC858 includes a high-performance 10-bit Analog-to-Digital Converter (ADC) with eight multiplexed analog input channels. The ADC uses a successive approximation technique to convert the analog voltage levels from up to eight different sources. The analog input channels of the ADC are available at AN0 - AN7.

#### Features

- Successive approximation
- 8-bit or 10-bit resolution
- Eight analog channels
- Four independent result registers
- Result data protection for slow CPU access (wait-for-read mode)
- Single conversion mode
- Autoscan functionality
- Limit checking for conversion results
- Data reduction filter (accumulation of up to 2 conversion results)
- Two independent conversion request sources with programmable priority
- Selectable conversion request trigger
- Flexible interrupt generation with configurable service nodes
- Programmable sample time
- Programmable clock divider
- Cancel/restart feature for running conversions
- Integrated sample and hold circuitry
- Compensation of offset errors
- Low power modes

#### 3.18.1 ADC Clocking Scheme

A common module clock  $f_{ADC}$  generates the various clock signals used by the analog and digital parts of the ADC module:

- $f_{ADCA}$  is input clock for the analog part.
- $f_{ADCI}$  is internal clock for the analog part (defines the time base for conversion length and the sample time). This clock is generated internally in the analog part, based on the input clock  $f_{ADCA}$  to generate a correct duty cycle for the analog components.
- $f_{ADCD}$  is input clock for the digital part.

**Figure 29** shows the clocking scheme of the ADC module. The prescaler ratio is selected by bit field CTC in register GLOBCTR. A prescaling ratio of 32 can be selected when the maximum performance of the ADC is not required.

Functional Description

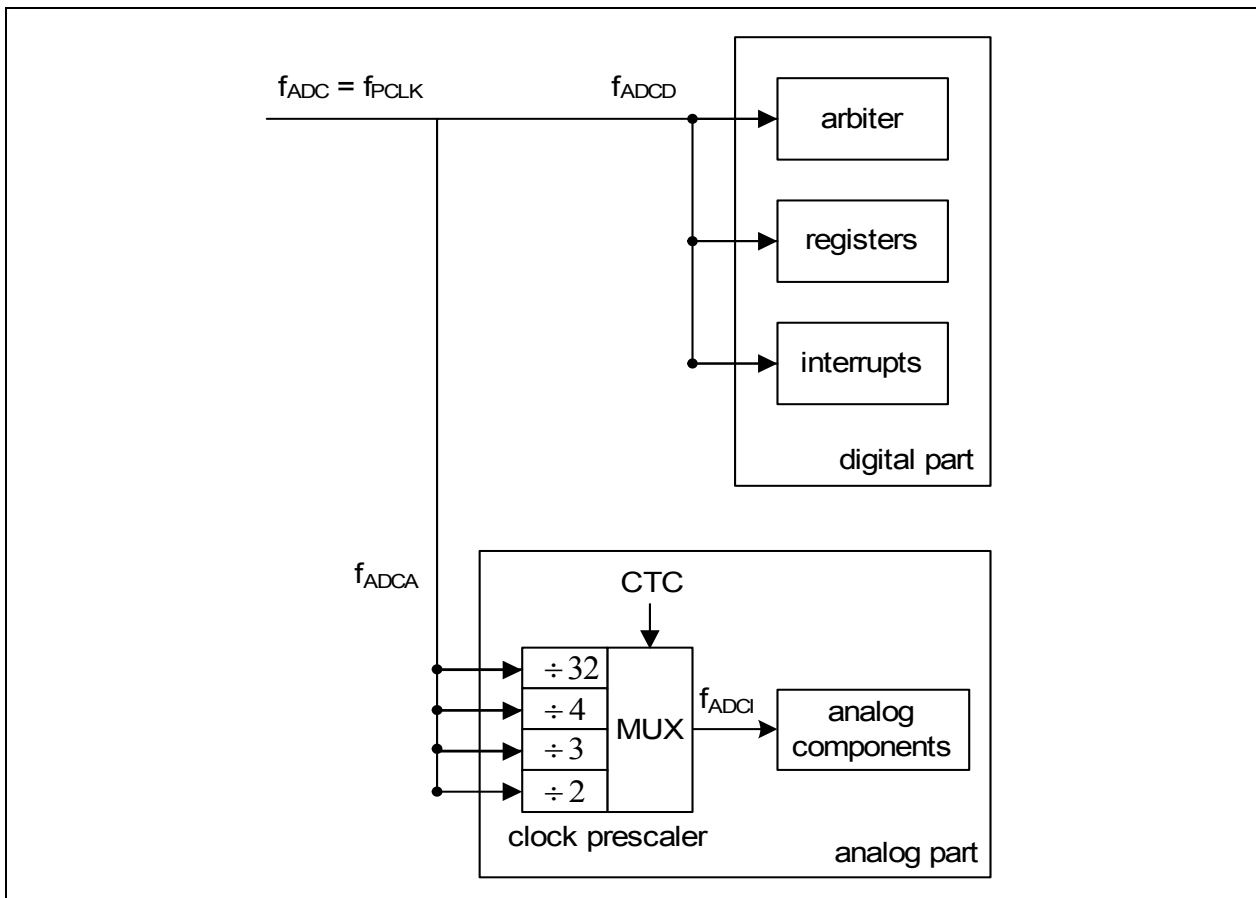

**Figure 29 ADC Clocking Scheme**

For module clock  $f_{ADC} = 24$  MHz, the analog clock  $f_{ADCI}$  frequency can be selected as shown in [Table 29](#).

**Table 29  $f_{ADCI}$  Frequency Selection**

Module Clock $f_{ADC}$	CTC	Prescaling Ratio	Analog Clock $f_{ADCI}$
24 MHz	00 <sub>B</sub>	÷ 2	12 MHz
	01 <sub>B</sub>	÷ 3	8 MHz
	10 <sub>B</sub>	÷ 4	6 MHz
	11 <sub>B</sub> (default)	÷ 32	750 kHz

During slow-down mode,  $f_{ADC}$  may be reduced further, for example, to 12 MHz or 6 MHz. However, it is important to note that the conversion error could increase due to loss of charges on the capacitors, if  $f_{ADC}$  becomes too low during slow-down mode.

**3.18.2 ADC Conversion Sequence**

The analog-to-digital conversion procedure consists of the following phases:

Functional Description

- Synchronization phase ( $t_{SYN}$ )
- Sample phase ( $t_S$ )
- Conversion phase
- Write result phase ( $t_{WR}$ )

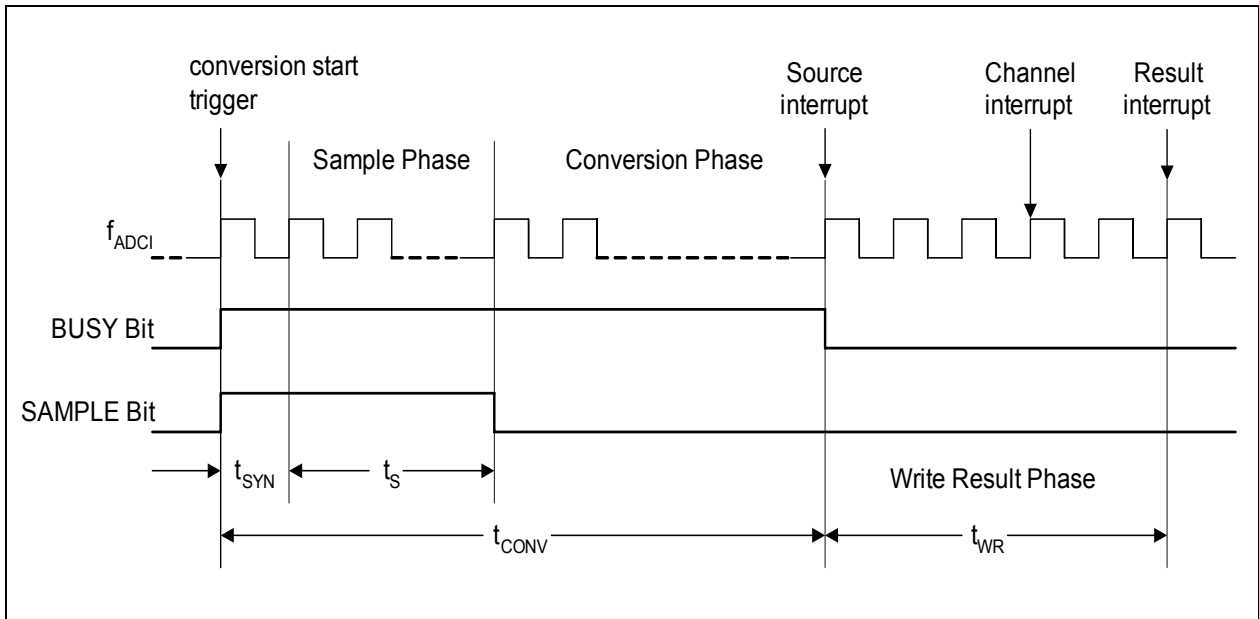

Figure 30 ADC Conversion Timing

### 3.19 On-Chip Debug Support

The On-Chip Debug Support (OCDS) provides the basic functionality required for the software development and debugging of XC800-based systems.

The OCDS design is based on these principles:

- Use the built-in debug functionality of the XC800 Core
- Add a minimum of hardware overhead
- Provide support for most of the operations by a Monitor Program
- Use standard interfaces to communicate with the Host (a Debugger)

#### Features

- Set breakpoints on instruction address and on address range within the Program Memory
- Set breakpoints on internal RAM address range
- Support unlimited software breakpoints in Flash/RAM code region
- Process external breaks via JTAG and upon activating a dedicated pin
- Step through the program code

The OCDS functional blocks are shown in [Figure 31](#). The Monitor Mode Control (MMC) block at the center of OCDS system brings together control signals and supports the overall functionality. The MMC communicates with the XC800 Core, primarily via the Debug Interface, and also receives reset and clock signals.

After processing memory address and control signals from the core, the MMC provides proper access to the dedicated extra-memories: a Monitor ROM (holding the code) and a Monitor RAM (for work-data and Monitor-stack).

The OCDS system is accessed through the JTAG<sup>1)</sup>, which is an interface dedicated exclusively for testing and debugging activities and is not normally used in an application. The dedicated MBC pin is used for external configuration and debugging control.

*Note: All the debug functionality described here can normally be used only after XC858 has been started in OCDS mode.*

1) The pins of the JTAG port can be assigned to either the primary port (Port 0) or either of the secondary ports (Ports 1 and 2/Port 5).

User must set the JTAG pins (TCK and TDI) as input during connection with the OCDS system.

Functional Description

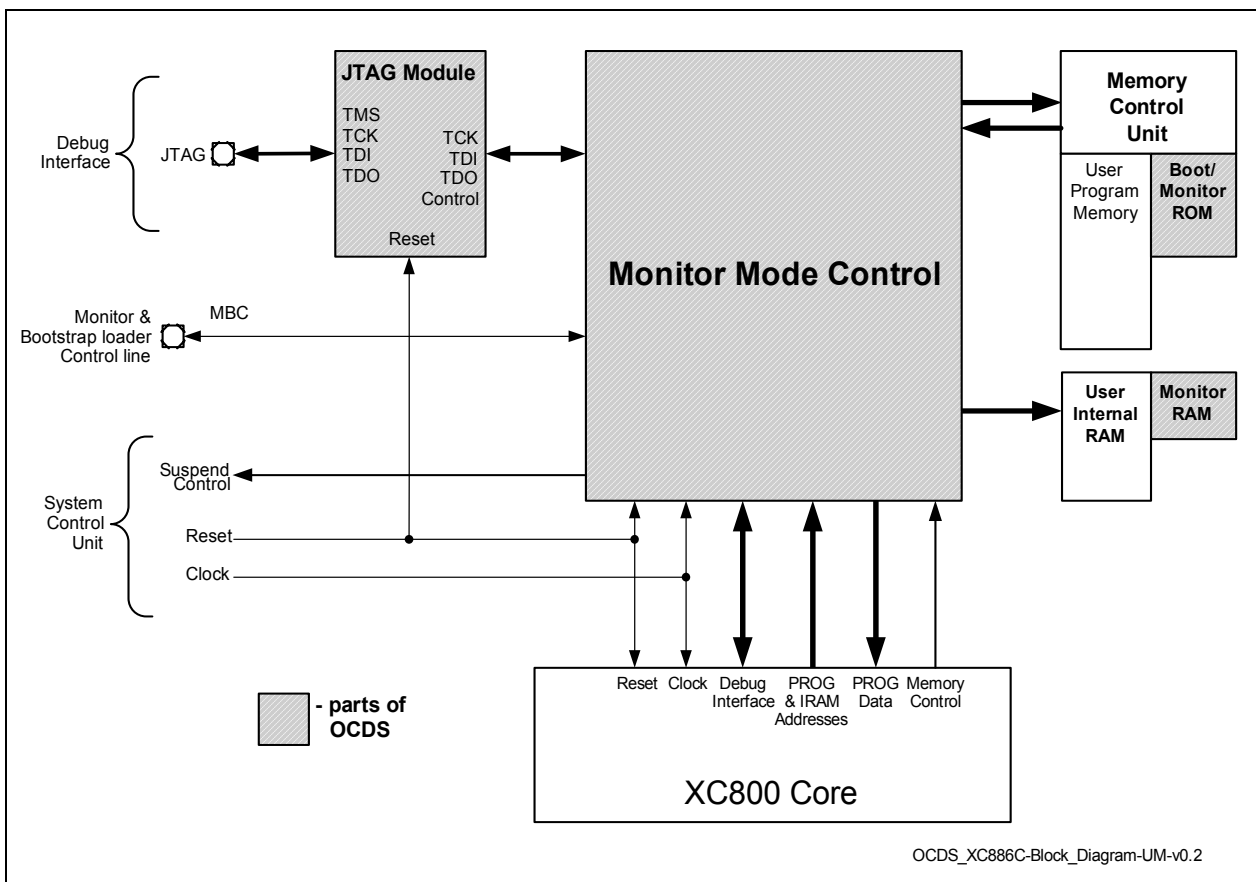

Figure 31 OCDS Block Diagram

### 3.19.1 JTAG ID Register

This is a read-only register located inside the JTAG module, and is used to recognize the device(s) connected to the JTAG interface. Its content is shifted out when INSTRUCTION register contains the IDCODE command (opcode 04<sub>H</sub>), and the same is also true immediately after reset.

The JTAG ID register contents for the XC858 Flash devices are given in [Table 30](#).

Table 30 JTAG ID Summary

Device Type	Device Name	JTAG ID
Flash	XC858CA-16FF	1018 2083 <sub>H</sub>
	XC858CA-13FF	1018 3083 <sub>H</sub>
	XC858CA-9FF	1018 4083 <sub>H</sub>

### 3.20 Chip Identification Number

The XC858 identity (ID) register is located at Page 1 of address B3<sub>H</sub>. The value of ID register is 49<sub>H</sub>. However, for easy identification of product variants, the Chip Identification Number, which is an unique number assigned to each product variant, is available. The differentiation is based on the product, variant type and device step information.

Two methods are provided to read a device’s chip identification number:

- In-application subroutine, GET\_CHIP\_INFO
- Bootstrap loader (BSL) mode A

**Table 31** lists the chip identification numbers of available XC858 Flash device variants.

**Table 31 Chip Identification Number**

Product Variant	Chip Identification Number
	AC-Step
<b>Flash Devices</b>	
XC858CA-16FF	4B5800C3 <sub>H</sub>
XC858CA-13FF	4B5904C3 <sub>H</sub>
XC858CA- 9FF	4B5A08C3 <sub>H</sub>

## 4 Electrical Parameters

**Chapter 4** provides the characteristics of the electrical parameters which are implementation-specific for the XC858.

### 4.1 General Parameters

The general parameters are described here to aid the users in interpreting the parameters mainly in [Section 4.2](#) and [Section 4.3](#).

#### 4.1.1 Parameter Interpretation

The parameters listed in this section represent partly the characteristics of the XC858 and partly its requirements on the system. To aid interpreting the parameters easily when evaluating them for a design, they are indicated by the abbreviations in the "Symbol" column:

- **CC**  
These parameters indicate **C**ontroller **C**haracteristics, which are distinctive features of the XC858 and must be regarded for a system design.
- **SR**  
These parameters indicate **S**ystem **R**equirements, which must be provided by the microcontroller system in which the XC858 is designed in.

### 4.1.2 Absolute Maximum Rating

Maximum ratings are the extreme limits to which the XC858 can be subjected to without permanent damage.

**Table 32 Absolute Maximum Rating Parameters**

Parameter	Symbol	Limit Values		Unit	Notes
		min.	max.		
Ambient temperature	$T_A$	-40	85	°C	under bias
Storage temperature	$T_{ST}$	-65	150	°C	
Junction temperature	$T_J$	-40	120	°C	under bias
Voltage on power supply pin with respect to $V_{SS}$	$V_{DDP}$	-0.5	6	V	
Voltage on any pin with respect to $V_{SS}$	$V_{IN}$	-0.5	$V_{DDP} + 0.5$ or max. 6	V	Whatever is lower
Input current on any pin during overload condition	$I_{IN}$	-10	10	mA	
Absolute sum of all input currents during overload condition	$\Sigma I_{IN} $	–	50	mA	

*Note: Stresses above those listed under “Absolute Maximum Ratings” may cause permanent damage to the device. This is a stress rating only and functional operation of the device at these or any other conditions above those indicated in the operational sections of this specification is not implied. Exposure to absolute maximum rating conditions for extended periods may affect device reliability. During absolute maximum rating overload conditions ( $V_{IN} > V_{DDP}$  or  $V_{IN} < V_{SS}$ ) the voltage on  $V_{DDP}$  pin with respect to ground ( $V_{SS}$ ) must not exceed the values defined by the absolute maximum ratings.*

### 4.1.3 Operating Conditions

The following operating conditions must not be exceeded in order to ensure correct operation of the XC858. All parameters mentioned in the following table refer to these operating conditions, unless otherwise noted.

**Table 33 Operating Condition Parameters**

Parameter	Symbol	Limit Values		Unit	Notes/ Conditions
		min.	max.		
Digital power supply voltage	$V_{DDP}$	4.5	5.5	V	5V Device
Digital ground voltage	$V_{SS}$	0		V	
CPU Clock Frequency <sup>1)</sup>	$f_{CCLK}$		24	MHz	
Ambient temperature	$T_A$	-40	85	°C	SAF-XC858

1)  $f_{CCLK}$  is the input frequency to the XC800 core. Please refer to [Figure 22](#) for detailed description.

## 4.2 DC Parameters

The electrical characteristics of the DC Parameters are detailed in this section.

### 4.2.1 Input/Output Characteristics

**Table 34** provides the characteristics of the input/output pins of the XC858.

**Table 34 Input/Output Characteristics (Operating Conditions apply)**

Parameter	Symbol		Limit Values		Unit	Test Conditions
			min.	max.		
<b><math>V_{DDP} = 5\text{ V Range}</math></b>						
Output low voltage	$V_{OL}$	CC	–	0.6	V	$I_{OL} = 9\text{ mA (DS = 0)}^{1)}$ $I_{OL} = 12\text{ mA (DS = 1)}^{2)}$
Output high voltage	$V_{OH}$	CC	2.4	–	V	$I_{OH} = -20\text{ mA (DS = 0)}^{1)}$ $I_{OH} = -25\text{ mA (DS = 1)}^{2)}$
Input low voltage	$V_{IL}$	SR	-0.3	0.8	V	CMOS Mode
Input high voltage	$V_{IH}$	SR	2.2	$V_{DDP}$	V	CMOS Mode
Input Hysteresis	$HYS$	CC	0.35	–	V	CMOS Mode <sup>3)4)</sup>
Input low voltage at XTAL1	$V_{ILX}$	SR	-0.3	0.8	V	
Input high voltage at XTAL1	$V_{IHX}$	SR	3.4	$V_{DDP}$	V	
Pull-up current	$I_{PU}$	SR	–	-20	$\mu\text{A}$	$V_{IH,min}$
			-88	–	$\mu\text{A}$	$V_{IL,max}$
Pull-down current	$I_{PD}$	SR	–	10	$\mu\text{A}$	$V_{IL,max}$
			66	–	$\mu\text{A}$	$V_{IH,min}$
Input leakage current	$I_{OZ1}$	CC	-1	1	$\mu\text{A}$	$0 < V_{IN} < V_{DDP}$ , $T_A \leq 85^\circ\text{C}^{5)}$
Overload current on any pin	$I_{OV}$	SR	-5	5	mA	
Absolute sum of overload currents	$\Sigma I_{OV} $	SR	–	25	mA	<sup>6)</sup>
Voltage on any pin during $V_{DDP}$ power off	$V_{PO}$	SR	–	0.3	V	<sup>7)</sup>

**Electrical Parameters**
**Table 34 Input/Output Characteristics (Operating Conditions apply) (cont'd)**

Parameter	Symbol	Limit Values		Unit	Test Conditions
		min.	max.		
Maximum current per pin (excluding $V_{DDP}$ and $V_{SS}$ )	$I_M$ SR SR	–	25	mA	
Maximum current for all pins (excluding $V_{DDP}$ and $V_{SS}$ )	$\Sigma I_M $ SR	–	150	mA	
Maximum current into $V_{DDP}$	$I_{MVDDP}$ SR	–	200	mA	6)
Maximum current out of $V_{SS}$	$I_{MVSS}$ SR	–	200	mA	6)

- 1) DS = 0 refers to the pin having a weak drive strength which is programmable via Px\_DS register.
- 2) DS = 1 refers to the pin having a strong drive strength which is programmable via Px\_DS register.
- 3) Not subjected to production test, verified by design/characterization. Hysteresis is implemented to avoid meta stable states and switching due to internal ground bounce. It cannot be guaranteed that it suppresses switching due to external system noise.
- 4) P0.1 has a minimum input hysteresis of 0.25V.
- 5) An additional error current ( $I_{INJ}$ ) will flow if an overload current flows through an adjacent pin. TMS pin and RESET pin have internal pull devices and are not included in the input leakage current characteristic.
- 6) Not subjected to production test, verified by design/characterization.
- 7) Not subjected to production test, verified by design/characterization. However, for applications with strict low power-down current requirements, it is mandatory that no active voltage source is supplied at any GPIO pin when  $V_{DDP}$  is powered off.

### 4.2.2 Supply Threshold Characteristics

Table 35 provides the characteristics of the supply threshold in the XC858.

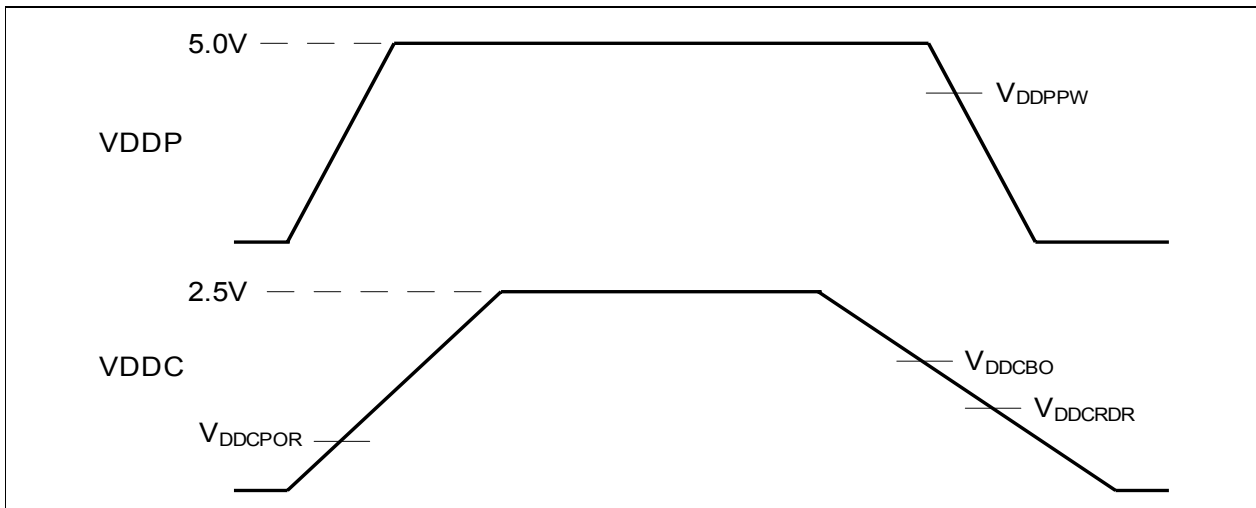

Figure 32 Supply Threshold Parameters

Table 35 Supply Threshold Parameters (Operating Conditions apply)

Parameters	Symbol		Limit Values			Unit
			min.	typ.	max.	
$V_{DDC}$ brownout voltage <sup>1)</sup>	$V_{DDCBO}$	CC	1.7	1.9	2.2	V
RAM data retention voltage	$V_{DDCRDR}$	CC	1.2	–	–	V
$V_{DDP}$ prewarning voltage	$V_{DDPPW}$	CC	3.8	4.2	4.5	V
Power-on reset voltage <sup>1)2)</sup>	$V_{DDCPOR}$	CC	1.7	1.9	2.2	V

1) Detection is enabled in both active and power-down mode.

2) The reset of EVR is extended by 300  $\mu$ s typically after the VDDC reaches the power-on reset voltage.

**Electrical Parameters**
**4.2.3 ADC Characteristics**

The values in the table below are given for an analog power supply between 4.5 V to 5.5 V. The ADC can be used with an analog power supply down to 3 V. But in this case, the analog parameters may show a reduced performance. All ground pins ( $V_{SS}$ ) must be externally connected to one single star point in the system. The voltage difference between the ground pins must not exceed 200mV.

**Table 36 ADC Characteristics (Operating Conditions apply;  $V_{DDP} = 5V$  Range)**

Parameter	Symbol		Limit Values			Unit	Test Conditions/ Remarks
			min.	typ .	max.		
Analog reference voltage	$V_{AREF}$	SR	$V_{AGND} + 1$	$V_{DDP}$	$V_{DDP} + 0.05$	V	<sup>1)</sup>
Analog reference ground	$V_{AGND}$	SR	$V_{SS} - 0.05$	$V_{SS}$	$V_{AREF} - 1$	V	<sup>1)</sup>
Analog input voltage range	$V_{AIN}$	SR	$V_{AGND}$	–	$V_{AREF}$	V	
ADC clocks	$f_{ADC}$		–	24	–	MHz	module clock <sup>1)</sup>
	$f_{ADCI}$		–	–	14 <sup>2)</sup>	MHz	internal analog clock <sup>1)</sup> See <a href="#">Figure 29</a>
Sample time	$t_S$	CC	$(2 + INPCR0.STC) \times t_{ADCI}$			$\mu s$	<sup>1)</sup>
Conversion time	$t_C$	CC	See <a href="#">Section 4.2.3.1</a>			$\mu s$	<sup>1)</sup>
Differential Nonlinearity	$ EA_{DNL} $	CC	–	–	1.5	LSB	10-bit conversion
Integral Nonlinearity	$ EA_{INL} $	CC	–	–	2.5	LSB	10-bit conversion
Offset	$ EA_{OFF} $	CC	–	–	3	LSB	10-bit conversion
Gain	$ EA_{GAIN} $	CC	–	–	2.5	LSB	10-bit conversion
Switched capacitance at the reference voltage input	$C_{AREFSW}$	CC	–	10	14	pF	<sup>1)3)</sup>
Switched capacitance at the analog voltage inputs	$C_{AINSW}$	CC	–	4	5	pF	<sup>1)4)</sup>

Electrical Parameters

**Table 36 ADC Characteristics (Operating Conditions apply;  $V_{DDP} = 5V$  Range)**

Parameter	Symbol		Limit Values			Unit	Test Conditions/ Remarks
			min.	typ .	max.		
Input resistance of the reference input	$R_{AREF}$	CC	–	1	2	k $\Omega$	1)
Input resistance of the selected analog channel	$R_{AIN}$	CC	–	1	3	k $\Omega$	1)

- 1) Not subjected to production test, verified by design/characterization.
- 2) This value includes the maximum oscillator deviation.
- 3) This represents an equivalent switched capacitance. This capacitance is not switched to the reference voltage at once. Instead of this, smaller capacitances are successively switched to the reference voltage.
- 4) The sampling capacity of the conversion C-Network is pre-charged to  $V_{AREF}/2$  before connecting the input to the C-Network. Because of the parasitic elements, the voltage measured at ANx is lower than  $V_{AREF}/2$ .

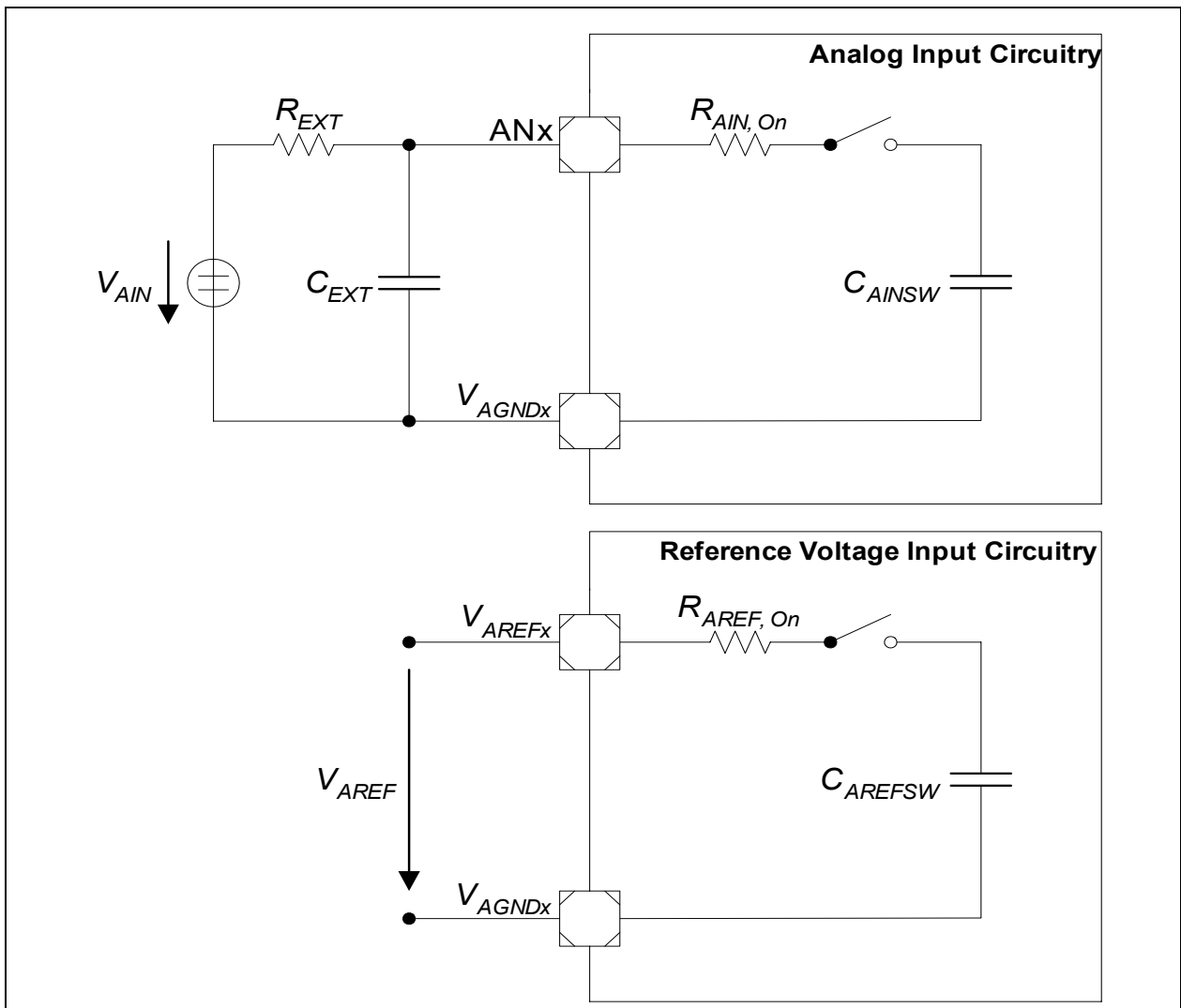

Figure 33 ADC Input Circuits

#### 4.2.3.1 ADC Conversion Timing

Conversion time,  $t_C = t_{ADC} \times (1 + r \times (3 + n + \text{STC}))$ , where

$r = \text{CTC} + 2$  for  $\text{CTC} = 00_B, 01_B$  or  $10_B$ ,

$r = 32$  for  $\text{CTC} = 11_B$ ,

$\text{CTC} = \text{Conversion Time Control (GLOBCTR.CTC)}$ ,

$\text{STC} = \text{Sample Time Control (INPCR0.STC)}$ ,

$n = 8$  or  $10$  (for 8-bit and 10-bit conversion respectively),

$t_{ADC} = 1 / f_{ADC}$

#### 4.2.4 Power Supply Current

**Table 37** and **Table 38** provide the characteristics of the power supply current in the XC858.

**Table 37 Power Supply Current Parameters (Operating Conditions apply;  $V_{DDP} = 5V$  range)**

Parameter	Symbol	Limit Values		Unit	Test Conditions
		typ. <sup>1)</sup>	max. <sup>2)</sup>		
<b><math>V_{DDP} = 5V</math> Range</b>					
Active Mode	$I_{DDP}$	37.5	45	mA	<sup>3)</sup>
Idle Mode	$I_{DDP}$	29.2	35	mA	<sup>4)</sup>
Active Mode with slow-down enabled	$I_{DDP}$	10	15	mA	<sup>5)</sup>
Idle Mode with slow-down enabled	$I_{DDP}$	9.2	14	mA	<sup>6)</sup>

1) The typical  $I_{DDP}$  values are based on preliminary measurements and are to be used as reference only. These values are periodically measured at  $T_A = +25\text{ °C}$  and  $V_{DDP} = 5.0\text{ V}$ .

2) The maximum  $I_{DDP}$  values are measured under worst case conditions ( $T_A = +85\text{ °C}$  and  $V_{DDP} = 5.5\text{ V}$ ).

3)  $I_{DDP}$  (active mode) is measured with: CPU clock and input clock to all peripherals running at 24 MHz with on-chip oscillator of 4 MHz,  $\overline{\text{RESET}} = V_{DDP}$ ; all other pins are disconnected, no load on ports.

4)  $I_{DDP}$  (idle mode) is measured with: CPU clock disabled, watchdog timer disabled, input clock to all peripherals enabled and running at 24 MHz,  $\overline{\text{RESET}} = V_{DDP}$ ; all other pins are disconnected, no load on ports.

5)  $I_{DDP}$  (active mode with slow-down mode) is measured with: CPU clock and input clock to all peripherals running at 1 MHz by setting CLKREL in CMCON to 1000<sub>B</sub>,  $\overline{\text{RESET}} = V_{DDP}$ ; all other pins are disconnected, no load on ports.

6)  $I_{DDP}$  (idle mode with slow-down mode) is measured with: CPU clock disabled, watchdog timer disabled, input clock to all peripherals enabled and running at 1 MHz by setting CLKREL in CMCON to 1000<sub>B</sub>,  $\overline{\text{RESET}} = V_{DDP}$ ; all other pins are disconnected, no load on ports.

**Electrical Parameters**
**Table 38 Power Down Current (Operating Conditions apply;  $V_{DDP} = 5V$  range)**

Parameter	Symbol	Limit Values		Unit	Test Conditions
		typ. <sup>1)</sup>	max. <sup>2)</sup>		
<b><math>V_{DDP} = 5V</math> Range</b>					
Power-Down Mode	$I_{PDP}$	20	60	$\mu A$	$T_A = + 25\text{ }^\circ C^{3)4)}$
		-	200	$\mu A$	$T_A = + 85\text{ }^\circ C^{4)5)}$

- 1) The typical  $I_{PDP}$  values are based on preliminary measurements and are to be used as reference only. These values are measured at  $V_{DDP} = 5.0 V$ .
- 2) The maximum  $I_{PDP}$  values are measured at  $V_{DDP} = 5.5 V$ .
- 3) IPDP has a maximum value of 350  $\mu A$  at  $T_A = + 85\text{ }^\circ C$ .
- 4)  $I_{PDP}$  is measured with:  $\overline{RESET} = V_{DDP}$ ,  $V_{AGND} = V_{SS}$ ,  $RXD/INT0 = V_{DDP}$ ; rest of the ports are programmed to be input with either internal pull devices enabled or driven externally to ensure no floating inputs.
- 5) Not subjected to production test, verified by design/characterization.

### 4.3 AC Parameters

The electrical characteristics of the AC Parameters are detailed in this section.

#### 4.3.1 Testing Waveforms

The testing waveforms for rise/fall time, output delay and output high impedance are shown in [Figure 34](#), [Figure 35](#) and [Figure 36](#).

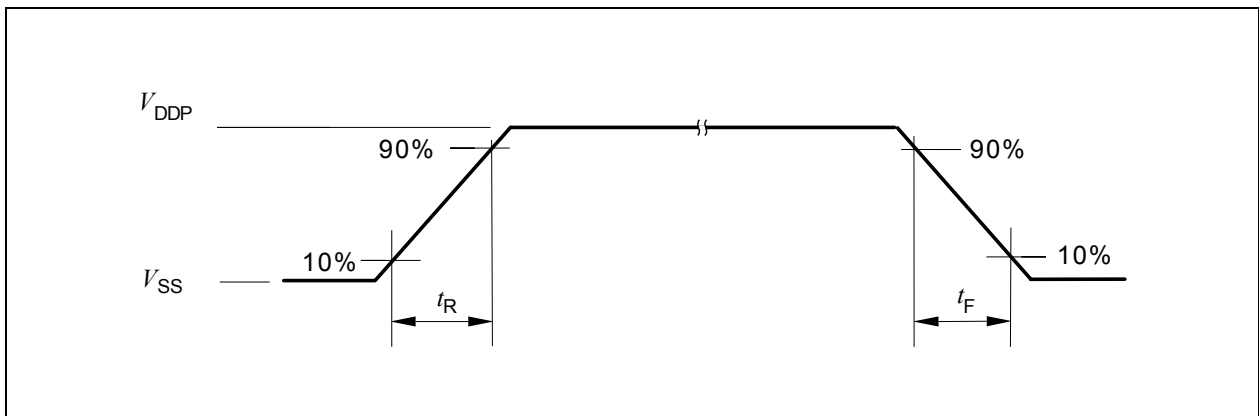

Figure 34 Rise/Fall Time Parameters

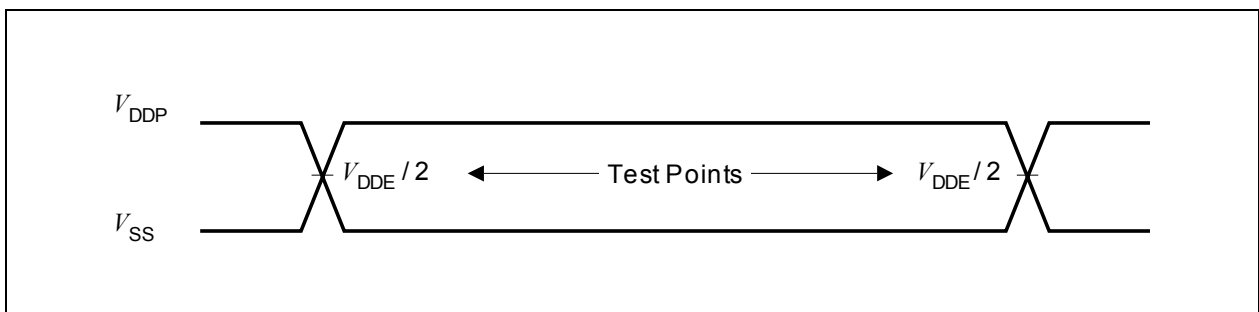

Figure 35 Testing Waveform, Output Delay

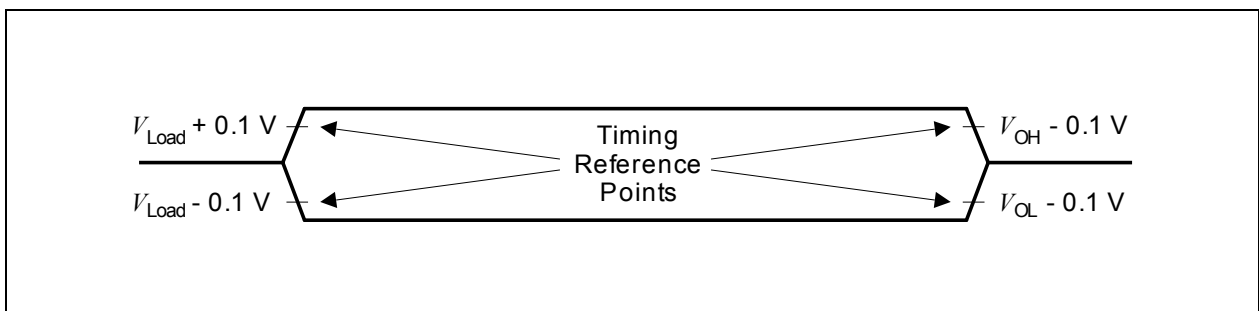

Figure 36 Testing Waveform, Output High Impedance

### 4.3.2 Output Rise/Fall Times

Table 39 provides the characteristics of the output rise/fall times in the XC858.

**Table 39 Output Rise/Fall Times Parameters (Operating Conditions apply)**

Parameter	Symbol	Limit Values		Unit	Test Conditions
		min.	max.		
<b><math>V_{DDP} = 5V</math> Range</b>					
Rise/fall times	$t_R, t_F$	–	10	ns	20 pF. <sup>1) 2)3)</sup>

- 1) Rise/Fall time measurements are taken with 10% - 90% of pad supply.
- 2) Not all parameters are 100% tested, but are verified by design/characterization and test correlation.
- 3) Additional rise/fall time valid for  $C_L = 20pF - 100pF @ 0.125 ns/pF$ .

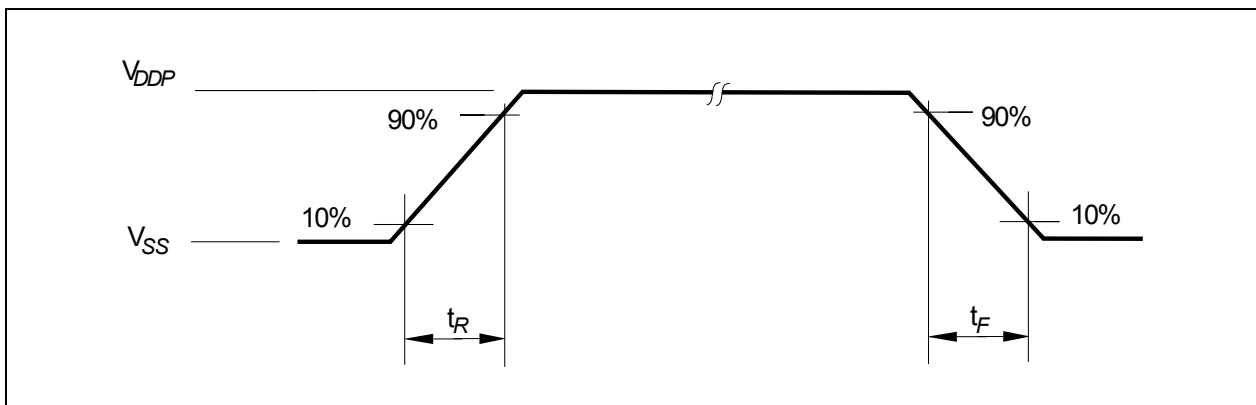

**Figure 37 Rise/Fall Times Parameters**

### 4.3.3 Power-on Reset and PLL Timing

**Table 40** provides the characteristics of the power-on reset and PLL timing in the XC858.

**Table 40 Power-On Reset and PLL Timing (Operating Conditions apply)**

Parameter	Symbol	CC	Limit Values			Unit	Test Conditions
			min.	typ.	max.		
On-Chip Oscillator start-up time	$t_{OSCST}$	CC	–	–	500	ns	1)
PLL lock-in in time	$t_{LOCK}$	CC	–	–	200	$\mu$ s	1)
PLL accumulated jitter	$D_P$		–	–	1.8	ns	1)2)

- 1) Not all parameters are 100% tested, but are verified by design/characterization and test correlation.
- 2) PLL lock at 144 MHz using a 4 MHz external oscillator. The PLL Divider settings are K = 2, N = 72 and P = 1.

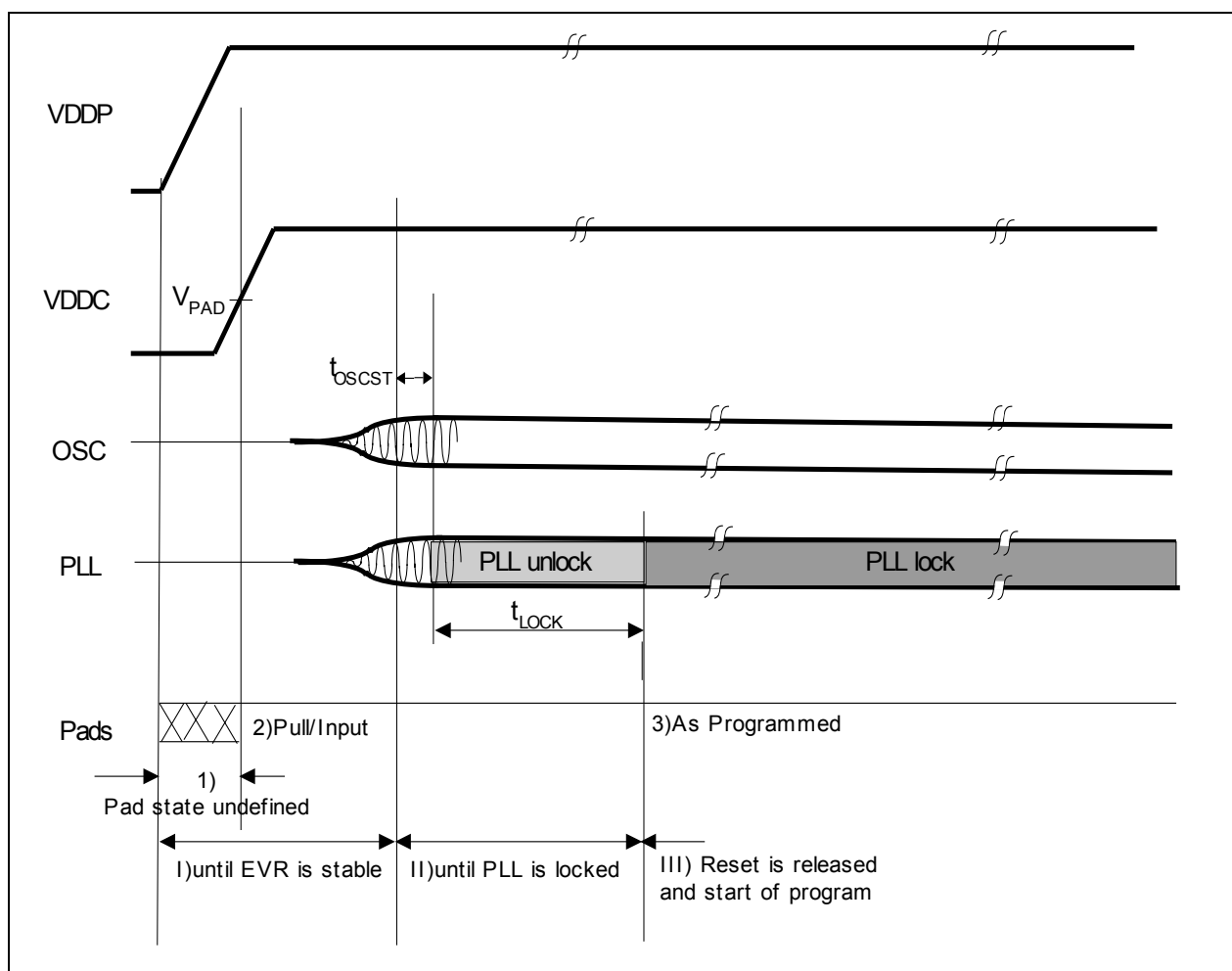

**Figure 38 Power-on Reset Timing**

### 4.3.4 On-Chip Oscillator Characteristics

**Table 41** provides the characteristics of the on-chip oscillator in the XC858.

**Table 41 On-chip Oscillator Characteristics (Operating Conditions apply)**

Parameter	Symbol	CC	Limit Values			Unit	Test Conditions
			min.	typ.	max.		
Nominal frequency	$f_{\text{NOM}}$	CC	3.88	4	4.12	MHz	under nominal conditions <sup>1)</sup> after IFX-backend trimming
Long term frequency deviation	$\Delta f_{\text{LT}}$	CC	-5	–	5	%	with respect to $f_{\text{NOM}}$ , over lifetime and temperature (-40°C to 85°C), for one given device after trimming
Short term frequency deviation	$\Delta f_{\text{ST}}$	CC	-1.0	–	1.0	%	with respect to $f_{\text{NOM}}$ , over core supply voltage (2.5 V $\pm$ 7.5%), for one given device after trimming

1) Nominal condition:  $V_{\text{DDC}} = 2.5 \text{ V}$ ,  $T_{\text{A}} = + 25^{\circ}\text{C}$ .

### 4.3.5 External Data Memory Characteristics

Table 42 shows the timing of the external data memory read cycle.

**Table 42 External Data Memory Read Timing (Operating Conditions apply)**

Parameter	Symbol		Limit Values		Unit	Test Conditions
			Min.	Max.		
$\overline{RD}$ pulse width	$t_1$	CC	$2 \cdot f_{CCLK} - 17$	-	ns	1)
Address valid to $\overline{RD}$	$t_2$	CC	$f_{CCLK} - 12$	-	ns	1)
$\overline{RD}$ to valid data in	$t_3$	SR	-	$1.5 \cdot f_{CCLK} - 27$	ns	1)
Address to valid data in	$t_4$	SR	-	$3 \cdot f_{CCLK} - 7$	ns	1)
Data hold after $\overline{RD}$	$t_5$	SR	$0.5 \cdot f_{CCLK} - 17$	-	ns	1)

1) Not all parameters are 100% tested, but are verified by design/characterization and test correlation.

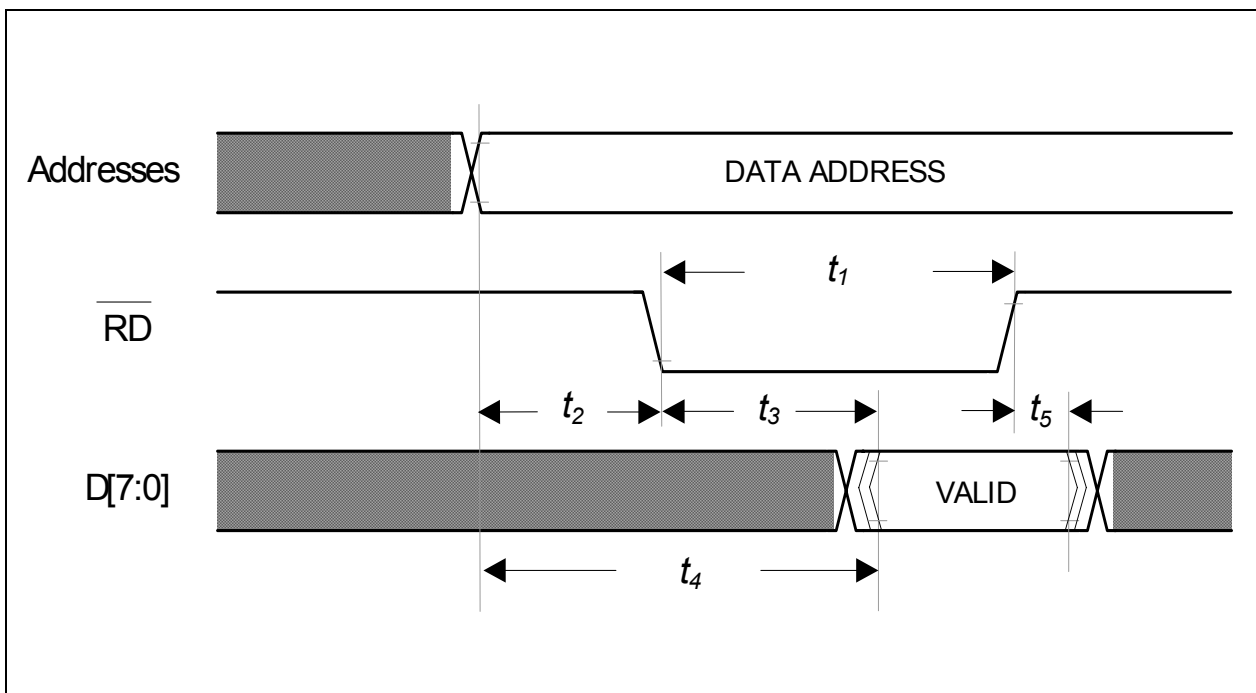

**Figure 39 External Data Memory Read Cycle**

Electrical Parameters

Table 43 shows the timing of the external data memory write cycle.

**Table 43 External Data Memory Write Timing (Operating Conditions apply)**

Parameter	Symbol	CC	Limit Values		Unit	Test Conditions
			Min.	Max.		
$\overline{WR}$ pulse width	$t_1$	CC	$f_{CCLK} - 10$	-	ns	1)
Address valid to $\overline{WR}$	$t_2$	CC	$2 * f_{CCLK} - 7$	-	ns	1)
Data valid to $\overline{WR}$ transition	$t_3$	SR	$f_{CCLK} - 5$	-	ns	1)
Data setup before $\overline{WR}$	$t_4$	SR	$9 * f_{CCLK} - 13$	-	ns	1)
Data hold after $\overline{WR}$	$t_5$	SR	$6 * f_{CCLK} - 3$	-	ns	1)

1) Not all parameters are 100% tested, but are verified by design/characterization and test correlation.

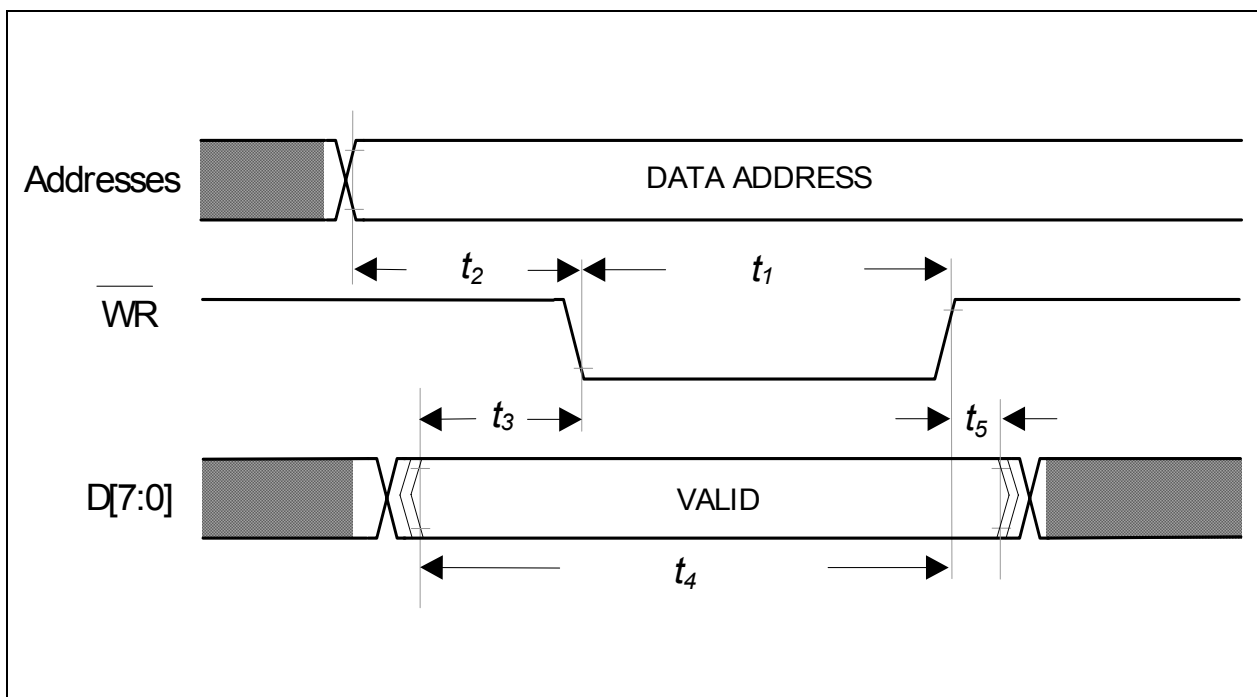

**Figure 40 External Data Memory Write Cycle**

### 4.3.6 External Clock Drive XTAL1

**Table 44** shows the parameters that define the external clock supply for XC858. These timing parameters are based on the direct XTAL1 drive of clock input signals. They are not applicable if an external crystal or ceramic resonator is considered.

**Table 44 External Clock Drive Characteristics (Operating Conditions apply)**

Parameter	Symbol	SR	Limit Values		Unit	Test Conditions
			Min.	Max.		
Oscillator period	$t_{osc}$	SR	50	500	ns	1)2)
High time	$t_1$	SR	15	-	ns	2)3)
Low time	$t_2$	SR	15	-	ns	2)3)
Rise time	$t_3$	SR	-	10	ns	2)3)
Fall time	$t_4$	SR	-	10	ns	2)3)

1) The clock input signals with 45-55% duty cycle are used.

2) Not all parameters are 100% tested, but are verified by design/characterization and test correlation.

3) The clock input signal must reach the defined levels  $V_{ILX}$  and  $V_{IHx}$ .

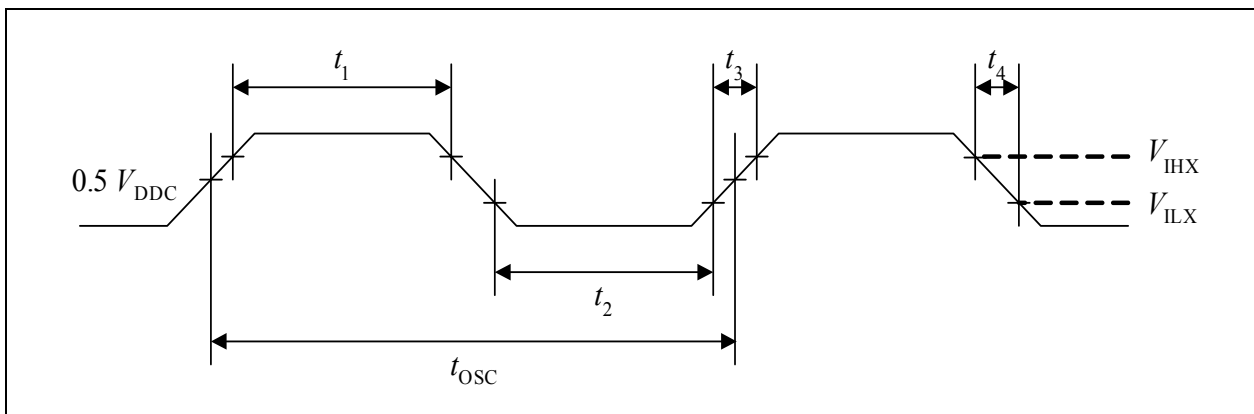

**Figure 41 External Clock Drive XTAL1**

### 4.3.7 JTAG Timing

Table 45 provides the characteristics of the JTAG timing in the XC858.

**Table 45 TCK Clock Timing (Operating Conditions apply; CL = 50 pF)**

Parameter	Symbol	Limits		Unit	Test Conditions
		min	max		
TCK clock period	$t_{TCK}$ SR	50	-	ns	1)
TCK high time	$t_1$ SR	20	-	ns	1)
TCK low time	$t_2$ SR	20	-	ns	1)
TCK clock rise time	$t_3$ SR	-	4	ns	1)
TCK clock fall time	$t_4$ SR	-	4	ns	1)

1) Not all parameters are 100% tested, but are verified by design/characterization and test correlation.

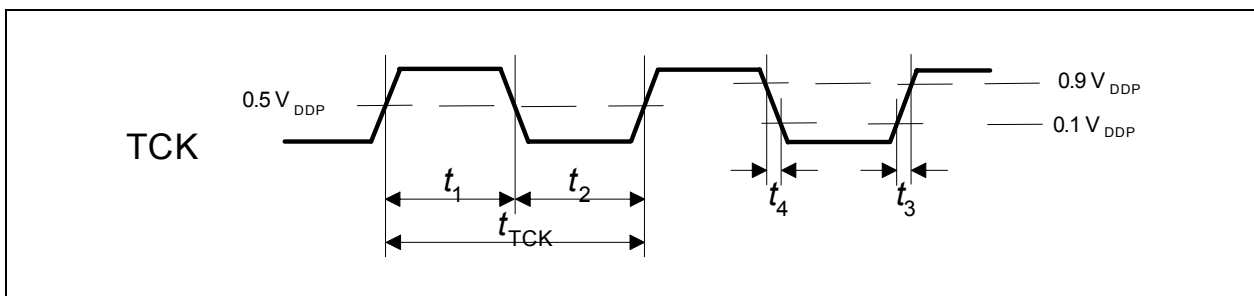

**Figure 42 TCK Clock Timing**

**Table 46 JTAG Timing (Operating Conditions apply; CL = 50 pF)**

Parameter	Symbol	Limits		Unit	Test Conditions
		min	max		
TMS setup to TCK	$t_1$ SR	8	-	ns	1)
TMS hold to TCK	$t_2$ SR	0	-	ns	1)
TDI setup to TCK	$t_1$ SR	8	-	ns	1)
TDI hold to TCK	$t_2$ SR	4	-	ns	1)
TDO valid output from TCK	$t_3$ CC	-	24	ns	1)

Electrical Parameters

**Table 46 JTAG Timing (Operating Conditions apply; CL = 50 pF) (cont'd)**

Parameter	Symbol	Limits		Unit	Test Conditions
		min	max		
TDO high impedance to valid output from TCK	$t_4$ CC	-	18	ns	1)
TDO valid output to high impedance from TCK	$t_5$ CC	-	21	ns	1)

1) Not all parameters are 100% tested, but are verified by design/characterization and test correlation.

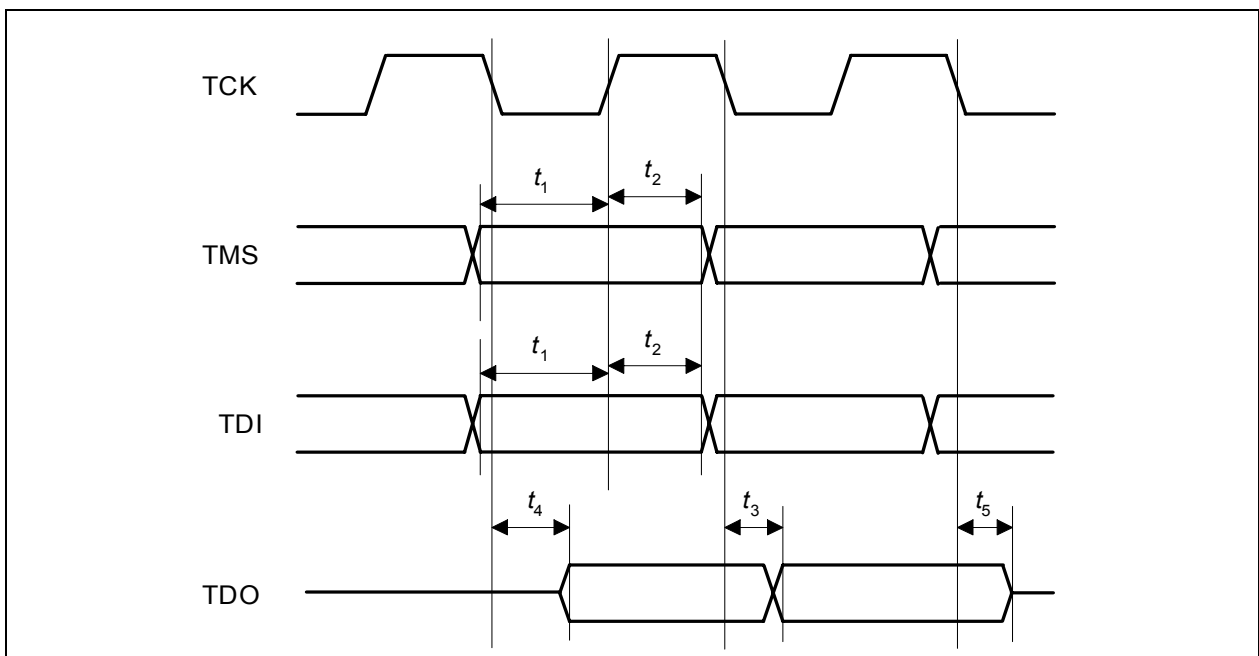

**Figure 43 JTAG Timing**

### 4.3.8 SSC Master Mode Timing

Table 47 provides the characteristics of the SSC timing in the XC858.

**Table 47 SSC Master Mode Timing (Operating Conditions apply; CL = 50 pF)**

Parameter	Symbol	Limit Values	Unit	Test Conditions
SCLK clock period	$t_0$ CC	$2 \cdot T_{SSC}$	ns	1)2)
MTSR delay from SCLK	$t_1$ CC	0	ns	2)
MRST setup to SCLK	$t_2$ SR	13	ns	2)
MRST hold from SCLK	$t_3$ SR	0	ns	2)

1)  $T_{SSCmin} = T_{CPU} = 1/f_{CPU}$ . When  $f_{CPU} = 24\text{ MHz}$ ,  $t_0 = 83.3\text{ ns}$ .  $T_{CPU}$  is the CPU clock period.

2) 1)Not all parameters are 100% tested, but are verified by design/characterization and test correlation.

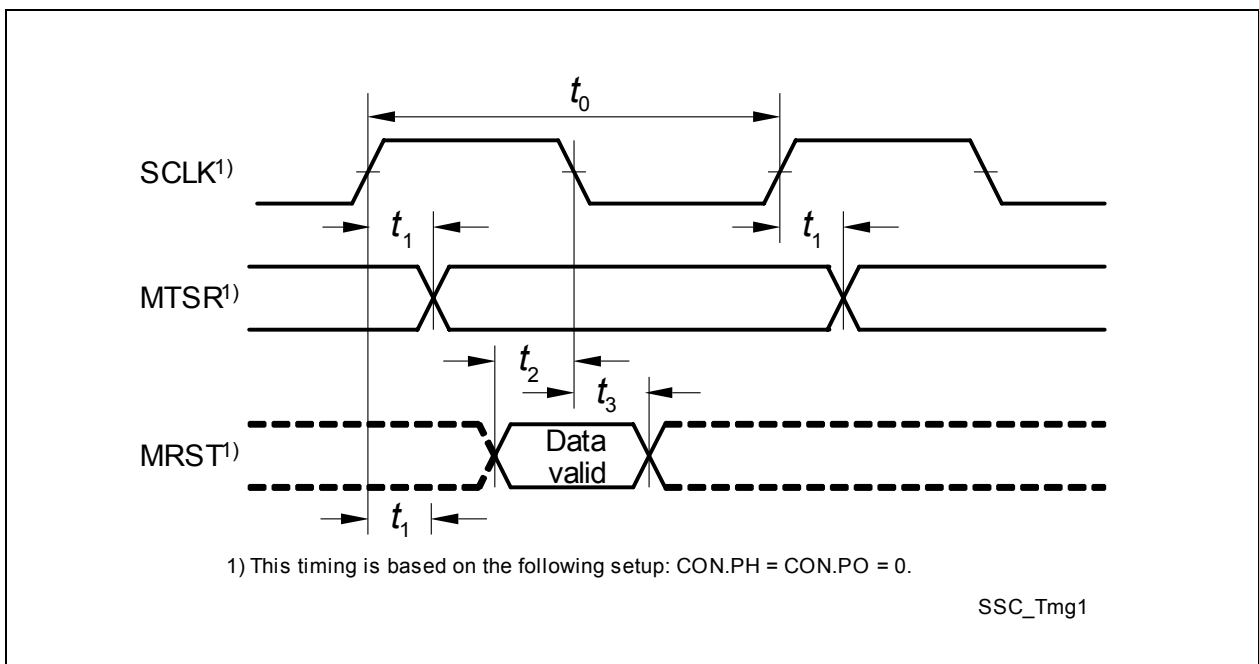

**Figure 44 SSC Master Mode Timing**

## 5 Package and Quality Declaration

Chapter 5 provides the information of the XC858 package and reliability section.

### 5.1 Package Parameters

Table 48 provides the thermal characteristics of the PG-LQFP-64-4 package used in XC858.

**Table 48 Thermal Characteristics of the Packages**

Parameter	Symbol	Limit Values		Unit	Notes
		Min.	Max.		
Thermal resistance junction case <sup>1)</sup>	$R_{TJC}$ CC	-	13.8	K/W	-
Thermal resistance junction lead <sup>1)</sup>	$R_{TJL}$ CC	-	34.6	K/W	-

1) The thermal resistances between the case and the ambient ( $R_{TCA}$ ), the lead and the ambient ( $R_{TLA}$ ) are to be combined with the thermal resistances between the junction and the case ( $R_{TJC}$ ), the junction and the lead ( $R_{TJL}$ ) given above, in order to calculate the total thermal resistance between the junction and the ambient ( $R_{TJA}$ ). The thermal resistances between the case and the ambient ( $R_{TCA}$ ), the lead and the ambient ( $R_{TLA}$ ) depend on the external system (PCB, case) characteristics, and are under user responsibility.

The junction temperature can be calculated using the following equation:  $T_J = T_A + R_{TJA} \times P_D$ , where the  $R_{TJA}$  is the total thermal resistance between the junction and the ambient. This total junction ambient resistance  $R_{TJA}$  can be obtained from the upper four partial thermal resistances, by

- a) simply adding only the two thermal resistances (junction lead and lead ambient), or
- b) by taking all four resistances into account, depending on the precision needed.

## 5.2 Package Outline

Figure 45 shows the package outlines of the XC858.

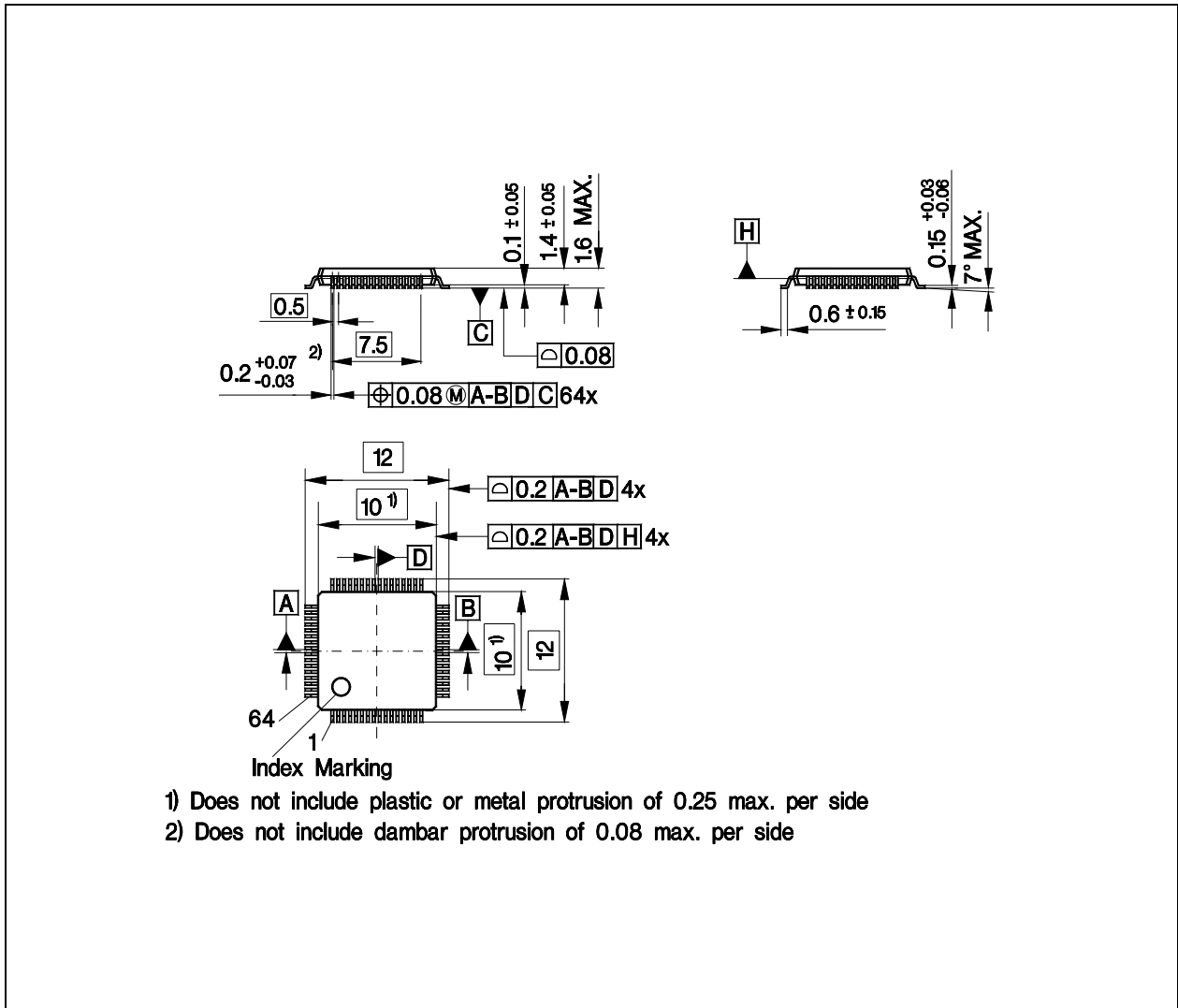

Figure 45 PG-LQFP-64-4 Package Outline

Package and Quality Declaration

5.3 Quality Declaration

Table 49 shows the characteristics of the quality parameters in the XC858.

Table 49 Quality Parameters

Parameter	Symbol	Limit Values		Unit	Notes
		Min.	Max.		
ESD susceptibility according to Human Body Model (HBM)	$V_{HBM}$	-	2000	V	Conforming to EIA/JESD22-A114-B
ESD susceptibility according to Charged Device Model (CDM) pins	$V_{CDM}$	-	500	V	Conforming to JESD22-C101-C

[www.infineon.com](http://www.infineon.com)

Published by Infineon Technologies AG

## Looking for pricing, stock, or lifecycle information?

Click below to explore more details on WIN SOURCE:

- ⊖ [View SAF-XC858CA-13FFI AC on WIN SOURCE](#)
- ⊖ [Infineon Technologies Information](#)

## Optimize Your Supply Chain with WIN SOURCE Solutions

- ✓ Global Sourcing Solution
- ✓ Obsolete Management
- ✓ Cost Control Management
- ✓ Shortage Management
- ✓ Alternative Solution
- ✓ Excess Inventory Management