



**THE DATASHEET OF
SPC5642AF2MLU1R**



MPC5642A Microcontroller Datasheet

This is the MPC5642A Datasheet set consisting of the following files:

- MPC5642A Datasheet *Addendum (MPC5642A_AD)*, Rev. 1
- MPC5642A Datasheet (*MPC5642A*), Rev. 3.1

MPC5642A Microcontroller Datasheet Addendum

This addendum describes corrections to the *MPC5642A Microcontroller Datasheet*, order number MPC5642A. For convenience, the addenda items are grouped by revision. Please check our website at <http://www.freescale.com/powerarchitecture> for the latest updates.

The current version available of the *MPC5642A Microcontroller Datasheet* is Revision 3.1.

Table of Contents

1	Addendum List for Revision 3.1	2
2	Revision History	2

1 Addendum List for Revision 3.1

Table 1. MPC5642A Rev 3.1 Addendum

Location	Description
Section 3.11, "Temperature Sensor Electrical Characteristics", Page 77	In "Temperature Sensor Electrical Characteristics" table, update the Min and Max value of "Accuracy" parameter to -20°C and +20°C, respectively.

2 Revision History

Table 2 provides a revision history for this datasheet addendum document.

Table 2. Revision History Table

Rev. Number	Substantive Changes	Date of Release
1.0	Initial release.	12/2014

How to Reach Us:

Home Page:
freescale.com

Web Support:
freescale.com/support

Information in this document is provided solely to enable system and software implementers to use Freescale products. There are no express or implied copyright licenses granted hereunder to design or fabricate any integrated circuits based on the information in this document.

Freescale reserves the right to make changes without further notice to any products herein. Freescale makes no warranty, representation, or guarantee regarding the suitability of its products for any particular purpose, nor does Freescale assume any liability arising out of the application or use of any product or circuit, and specifically disclaims any and all liability, including without limitation consequential or incidental damages. "Typical" parameters that may be provided in Freescale data sheets and/or specifications can and do vary in different applications, and actual performance may vary over time. All operating parameters, including "typicals," must be validated for each customer application by customer's technical experts. Freescale does not convey any license under its patent rights nor the rights of others. Freescale sells products pursuant to standard terms and conditions of sale, which can be found at the following address: freescale.com/SalesTermsandConditions.

Freescale, the Freescale logo, Altivec, C-5, CodeTest, CodeWarrior, ColdFire, C-Ware, Energy Efficient Solutions logo, Kinetis, mobileGT, PowerQUICC, Processor Expert, QorIQ, Qorivva, StarCore, Symphony, and VortiQa are trademarks of Freescale Semiconductor, Inc., Reg. U.S. Pat. & Tm. Off. Airfast, BeeKit, BeeStack, ColdFire+, CoreNet, Flexis, MagniV, MXC, Platform in a Package, QorIQ Qonverge, QUICC Engine, Ready Play, SafeAssure, SMARTMOS, TurboLink, Vybrid, and Xtrinsic are trademarks of Freescale Semiconductor, Inc. All other product or service names are the property of their respective owners.

© 2014 Freescale Semiconductor, Inc.

Document Number: MPC5642A_AD
Rev. 1
12/2014



Qorivva MPC5642A Microcontroller Data Sheet

MPC5642A

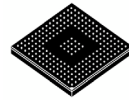

208 MAPBGA
(17 x 17 mm)

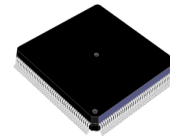

176 LQFP
(24 x 24 mm)

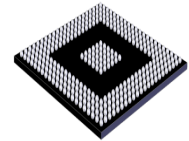

324 TEPBGA
(23 x 23 mm)

- 150 MHz e200z4 Power Architecture core
 - Variable length instruction encoding (VLE)
 - Superscalar architecture with 2 execution units
 - Up to 2 integer or floating point instructions per cycle
 - Up to 4 multiply and accumulate operations per cycle
- Memory organization
 - 2 MB on-chip flash memory with ECC and read-while-write (RWW)
 - 128 KB on-chip SRAM with standby functionality (32 KB) and ECC
 - 8 KB instruction cache (with line locking), configurable as 2- or 4-way
 - 14 + 3 KB eTPU code and data RAM
 - 4 x 4 crossbar switch (XBAR)
 - 24-entry MMU
- Fail Safe Protection
 - 16-entry Memory Protection Unit (MPU)
 - CRC unit with 3 submodules
 - Junction temperature sensor
- Interrupt
 - Configurable interrupt controller (INTC) with non-maskable interrupt (NMI)
 - 64-channel eDMA
- Serial channels
 - 3 eSCI modules
 - 3 DSPI modules (2 of which support downstream Micro Second Channel [MSC])
 - 3 FlexCAN modules with 64 message buffers each
 - 1 FlexRay module (V2.1) up to 10 Mbit/s w/dual or single channel, 128 message objects, ECC
- 1 eMIOS
 - 24 unified channels
- 1 eTPU2 (second generation eTPU)
 - 32 standard channels
- 1 reaction module (6 channels with 3 outputs per channel)
- 2 enhanced queued analog-to-digital converters (eQADCs)
 - Forty 12-bit input channels (multiplexed on 2 ADCs); expandable to 56 channels with external multiplexers
 - 6 command queues
 - Trigger and DMA support
 - 688 ns minimum conversion time
- On-chip CAN/SCI Bootstrap loader with Boot Assist Module (BAM)
- Nexus: Class 3+ for core; Class 1 for eTPU
- JTAG (5-pin)
- Development Trigger Semaphore (DTS)
 - EVTO pin for communication with external tool
- Clock generation
 - On-chip 4–40 MHz main oscillator
 - On-chip FMPLL (frequency-modulated phase-locked loop)
- Up to 112 general purpose I/O lines
 - Individually programmable as input, output or special function
 - Programmable threshold (hysteresis)
- Power reduction modes: slow, stop, and standby
- Flexible supply scheme
 - 5 V single supply with external ballast
 - Multiple external supply: 5 V, 3.3 V, and 1.2 V

Table of Contents

1	Introduction	3	2.5	Signal details	49
1.1	Document overview	3	3	Electrical characteristics	55
1.2	Description	3	3.1	Parameter classification	55
1.3	Device feature summary	3	3.2	Maximum ratings	56
1.4	Block diagram	5	3.3	Thermal characteristics	58
1.5	Feature details	9	3.3.1	General notes for specifications at maximum junction temperature	59
1.5.1	e200z4 core	9	3.4	EMI (electromagnetic interference) characteristics	61
1.5.2	Crossbar switch (XBAR)	10	3.5	Electrostatic discharge (ESD) characteristics	62
1.5.3	Enhanced direct memory access (eDMA)	10	3.6	Power management control (PMC) and power on reset (POR) electrical specifications	62
1.5.4	Interrupt controller (INTC)	11	3.6.1	Regulator example	65
1.5.5	Memory protection unit (MPU)	11	3.6.2	Recommended power transistors	66
1.5.6	Frequency-modulated phase-locked loop (FMPLL)	12	3.7	Power up/down sequencing	66
1.5.7	System integration unit (SIU)	12	3.8	DC electrical specifications	67
1.5.8	Flash memory	13	3.9	I/O pad current specifications	72
1.5.9	Static random access memory (SRAM)	14	3.9.1	I/O pad V_{RC33} current specifications	73
1.5.10	Boot assist module (BAM)	14	3.9.2	LVDS pad specifications	74
1.5.11	Enhanced modular input/output system (eMIOS)	14	3.10	Oscillator and PLLMRFM electrical characteristics	75
1.5.12	Second generation enhanced time processing unit (eTPU2)	15	3.11	Temperature sensor electrical characteristics	77
1.5.13	Reaction module (REACM)	16	3.12	eQADC electrical characteristics	77
1.5.14	Enhanced queued analog-to-digital converter (eQADC)	17	3.13	Configuring SRAM wait states	79
1.5.15	Deserial serial peripheral interface (DSPI)	18	3.14	Platform flash controller electrical characteristics	80
1.5.16	Enhanced serial communications interface (eSCI)	19	3.15	Flash memory electrical characteristics	80
1.5.17	Controller area network (FlexCAN)	19	3.16	AC specifications	82
1.5.18	FlexRay	20	3.16.1	Pad AC specifications	82
1.5.19	System timers	20	3.17	AC timing	86
1.5.20	Software watchdog timer (SWT)	21	3.17.1	Reset and configuration pin timing	86
1.5.21	Cyclic redundancy check (CRC) module	21	3.17.2	IEEE 1149.1 interface timing	86
1.5.22	Error correction status module (ECSM)	22	3.17.3	Nexus timing	90
1.5.23	Peripheral bridge (PBRIDGE)	22	3.17.4	Calibration bus interface timing	95
1.5.24	Calibration bus interface	22	3.17.5	External interrupt timing (IRQ pin)	99
1.5.25	Power management controller (PMC)	22	3.17.6	eTPU timing	99
1.5.26	Nexus port controller (NPC)	23	3.17.7	eMIOS timing	100
1.5.27	JTAG controller (JTAGC)	23	3.17.8	DSPI timing	100
1.5.28	Development trigger semaphore (DTS)	23	3.17.9	eQADC SSI timing	107
3.17.10	FlexCAN system clock source	108	4	Packages	109
2	Pinout and signal description	23	4.1	Package mechanical data	109
2.1	176 LQFP pinout	24	4.1.1	176 LQFP	109
2.2	208 MAP BGA ballmap	25	4.1.2	208 MAPBGA	112
2.3	324 TEPBGA ballmap	26	4.1.3	324 TEPBGA	114
2.4	Signal summary	30	5	Ordering information	116
			6	Document revision history	117

1 Introduction

1.1 Document overview

This document provides electrical specifications, pin assignments, and package diagrams for the MPC5642A series of microcontroller units (MCUs). It also describes the device features and highlights important electrical and physical characteristics. For functional characteristics, refer to the device reference manual.

1.2 Description

This microcontroller is a 32-bit system-on-chip (SoC) device intended for use in mid-range engine control and automotive transmission control applications.

It is compatible with devices in Freescale's MPC5600 family and offers performance and capabilities beyond the MPC5632M devices.

The microcontroller's e200z4 host processor core is built on the Power Architecture® technology and designed specifically for embedded applications. In addition to the Power Architecture technology, this core supports instructions for digital signal processing (DSP).

The device has two levels of memory hierarchy consisting of 8 KB of instruction cache, backed by a 128 KB on-chip SRAM and a 2 MB internal flash memory.

For development, the device includes a calibration bus that is accessible only when using the Freescale VertiCal Calibration System.

1.3 Device feature summary

Table 1 summarizes the MPC5642A features and compares them to those of the MPC5644A.

Table 1. MPC5642A device feature summary

Feature	MPC5642A	MPC5644A
Process	90 nm	
Core	e200z4	
SIMD	Yes	
VLE	Yes	
Cache	8 KB instruction	
Non-Maskable Interrupt (NMI)	NMI and Critical Interrupt	
MMU	24-entry	
MPU	16-entry	
Crossbar switch	4 × 4	5 × 4
Core performance	0–150 MHz	
Windowing software watchdog	Yes	
Core Nexus	Class 3+	
SRAM	128 KB	192 KB
Flash	2 MB	4 MB
Flash fetch accelerator	4 × 128-bit	4 × 256-bit

Table 1. MPC5642A device feature summary (continued)

Feature		MPC5642A	MPC5644A
External bus		None	16-bit (incl. 32-bit muxed)
Calibration bus		16-bit (incl. 32-bit muxed)	
DMA		64 channels	
DMA Nexus		None	
Serial		3	
	eSCI_A	Yes (MSC uplink)	
	eSCI_B	Yes (MSC uplink)	
	eSCI_C	Yes	
CAN		3	
	CAN_A	64 message buffers	
	CAN_B	64 message buffers	
	CAN_C	64 message buffers	
SPI		3	
	Micro Second Channel (MSC) bus downlink	Yes	
	DSPI_A	No	
	DSPI_B	Yes (with LVDS)	
	DSPI_C	Yes (with LVDS)	
	DSPI_D	Yes	
FlexRay		Yes	
System timers		5 PIT channels 4 STM channels 1 Software Watchdog	
eMIOS		24 channels	
eTPU		32-channel eTPU2	
	Code memory	14 KB	
	Data memory	3 KB	
	Reaction module	6 channels	
Interrupt controller		485 channels ¹	
ADC		40 channels	
	ADC_0	Yes	
	ADC_1	Yes	
	Temperature sensor	Yes	
	Variable gain amplifier	Yes	
	Decimation filter	2	
	Sensor diagnostics	Yes	

Table 1. MPC5642A device feature summary (continued)

Feature	MPC5642A	MPC5644A
CRC	Yes	
FMPLL	Yes	
VRC	Yes	
Supplies	5 V, 3.3 V ²	
Low-power modes	Stop mode Slow mode	
Packages	176 LQFP ³ 208 MAPBGA ^{3,4} 324 TEPBGA ⁵ 496-pin CSP ⁶	176 LQFP ³ 208 MAPBGA ^{3,4} 324 TEPBGA ⁵ 496-pin CSP ⁶

¹ 197 interrupt vectors are reserved.

² 5 V single supply only for 176 LQFP

³ Pinout compatible with Freescale's MPC5634M devices

⁴ Pinout compatible with Freescale's MPC5534

⁵ Ballmap upwardly compatible with the standardized package ballmap used for various Freescale MPC563xM family members

⁶ For Freescale VertiCal Calibration System only

1.4 Block diagram

Figure 1 shows a top-level block diagram of the MPC5642A series.

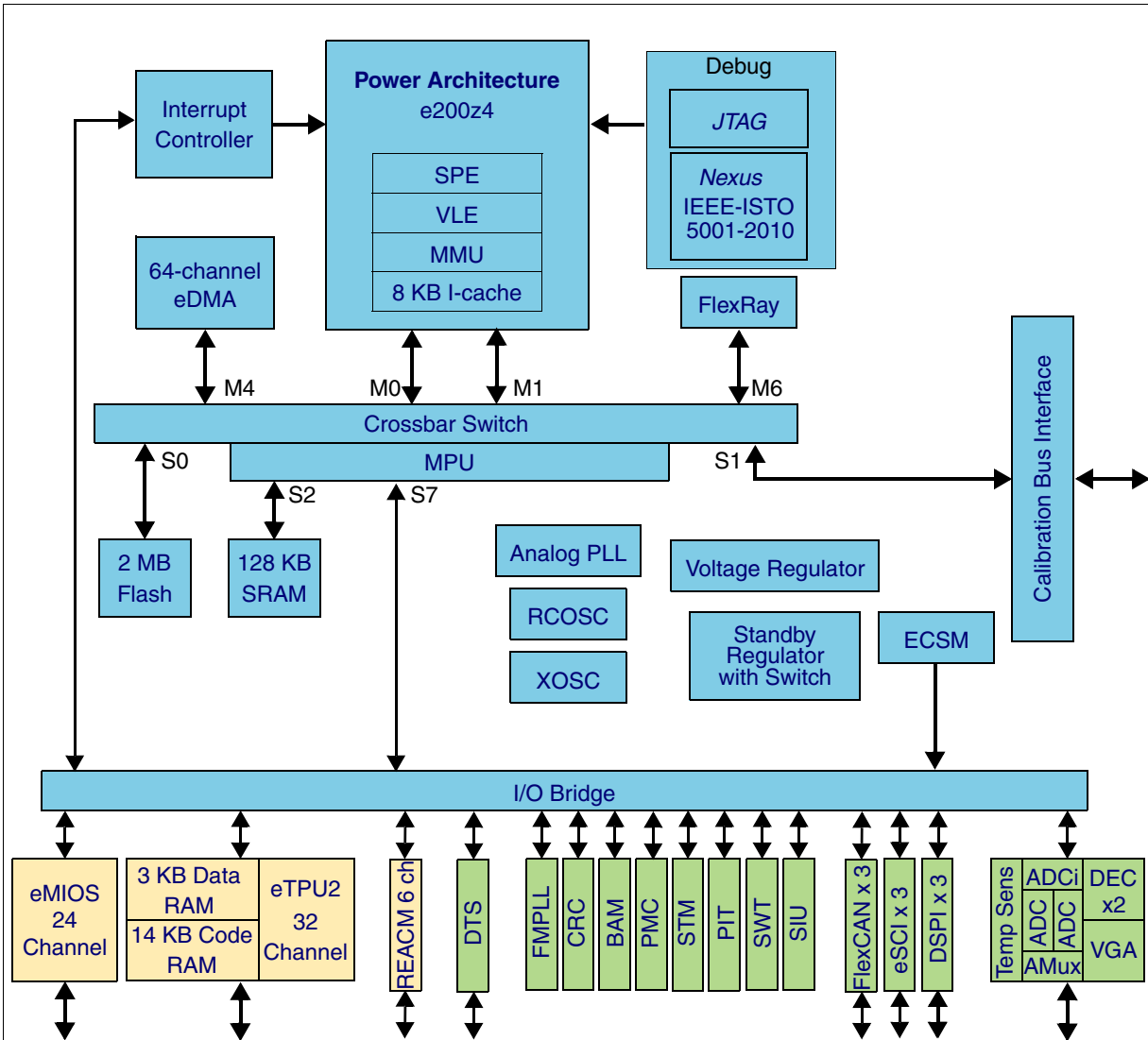

LEGEND

- | | |
|--|---|
| ADC – Analog to Digital Converter | JTAG – IEEE 1149.1 Test Controller |
| ADCi – ADC interface | MMU – Memory Management Unit |
| AMux – Analog Multiplexer | MPU – Memory Protection Unit |
| BAM – Boot Assist Module | PMC – Power Management Controller |
| CRC – Cyclic Redundancy Check unit | PIT – Periodic Interrupt Timer |
| DEC – Decimation Filter | RCOSC – Low-speed RC Oscillator |
| DTS – Development Trigger Semaphore | REACM – Reaction Module |
| DSPI – Deserial/Serial Peripheral Interface | SIU – System Integration Unit |
| ECSM – Error Correction Status Module | SPE – Signal Processing Extension |
| eDMA – Enhanced Direct Memory Access | SRAM – Static RAM |
| eMIOS – Enhanced Modular Input Output System | STM – System Timer Module |
| eSCI – Enhanced Serial Communications Interface | SWT – Software Watchdog Timer |
| eTPU2 – Second gen. Enhanced Time Processing Unit | VGA – Variable Gain Amplifier |
| FlexCAN – Controller Area Network | VLE – Variable Length (instruction) Encoding |
| FMPLL – Frequency-Modulated Phase-Locked Loop | XOSC – XTAL Oscillator |

Figure 1. MPC5642A series block diagram

Table 2 summarizes the functions of the blocks present on the MPC5642A series microcontrollers.

Table 2. MPC5642A series block summary

Block	Function
Boot assist module (BAM)	Block of read-only memory containing executable code that searches for user-supplied boot code and, if none is found, executes the BAM boot code resident in device ROM
Calibration bus interface	Transfers data across the crossbar switch to/from peripherals attached to the calibration system connector
Controller area network (FlexCAN)	Supports the standard CAN communications protocol
Crossbar switch (XBAR)	Internal busmaster
Cyclic redundancy check (CRC)	CRC checksum generator
Deserial serial peripheral interface (DSPI)	Provides a synchronous serial interface for communication with external devices
e200z4 core	Executes programs and interrupt handlers
Enhanced direct memory access (eDMA)	Performs complex data movements with minimal intervention from the core.
Enhanced modular input-output system (eMIOS)	Provides the functionality to generate or measure events
Enhanced queued analog-to-digital converter (eQADC)	Provides accurate and fast conversions for a wide range of applications
Enhanced serial communication interface (eSCI)	Provides asynchronous serial communication capability with peripheral devices and other microcontroller units
Enhanced time processor unit (eTPU2)	Second-generation co-processor processes real-time input events, performs output waveform generation, and accesses shared data without host intervention
Error Correction Status Module (ECSM)	The Error Correction Status Module supports a number of miscellaneous control functions for the platform, and includes registers for capturing information on platform memory errors if error-correcting codes (ECC) are implemented
Flash memory	Provides storage for program code, constants, and variables
FlexRay	Provides high-speed distributed control for advanced automotive applications
Frequency-modulated phase-locked loop (FMPLL)	Generates high-speed system clocks and supports programmable frequency modulation
Interrupt controller (INTC)	Provides priority-based preemptive scheduling of interrupt requests
JTAG controller	Provides the means to test chip functionality and connectivity while remaining transparent to system logic when not in test mode
Memory protection unit (MPU)	Provides hardware access control for all memory references generated
Nexus port controller (NPC)	Provides real-time development support capabilities in compliance with the IEEE-ISTO 5001-2010 standard
Periodic interrupt timer (PIT)	Produces periodic interrupts and triggers
Reaction Module (REACM)	Works in conjunction with the eQADC and eTPU2 to increase system performance by removing the CPU from the current control loop.

Table 2. MPC5642A series block summary (continued)

Block	Function
System Integration Unit (SIU)	Controls MCU reset configuration, pad configuration, external interrupt, general purpose I/O (GPIO), internal peripheral multiplexing, and the system reset operation.
Static random-access memory (SRAM)	Provides storage for program code, constants, and variables
System timers	Includes periodic interrupt timer with real-time interrupt; output compare timer and system watchdog timer
System watchdog timer (SWT)	Provides protection from runaway code
Temperature sensor	Provides the temperature of the device as an analog value

1.5 Feature details

1.5.1 e200z4 core

MPC5642A devices have a high performance e200z4 core processor:

- 32-bit Power Architecture technology programmer's model
- Variable Length Encoding (VLE) enhancements
- Dual issue, 32-bit Power Architecture technology compliant CPU
- 8 KB, 2/4-way set associative instruction cache
- Thirty-two 64-bit general purpose registers (GPRs)
- Memory Management Unit (MMU) with 24-entry fully-associative translation look-aside buffer (TLB)
- Harvard Architecture: Separate instruction bus and load/store bus
- Vectored interrupt support
- Non-maskable interrupt input
- Critical Interrupt input
- New 'Wait for Interrupt' instruction, to be used with new low power modes
- Reservation instructions for implementing read-modify-write accesses
- Signal processing extension (SPE) APU
- Single Precision Floating point (scalar and vector)
- Nexus Class 3+ debug
- Process ID manipulation for the MMU using an external tool
- In-order execution and retirement
- Precise exception handling
- Branch processing unit
 - Dedicated branch address calculation adder
 - Branch target prefetching using 8-entry BTB
- Supports independent instruction and data accesses to different memory subsystems, such as SRAM and flash memory via independent Instruction and Data BIUs
- Load/store unit
 - 2-cycle load latency
 - Fully pipelined
 - Big and Little endian support
 - Misaligned access support
- Signal Processing Extension (SPE1.1) APU supporting SIMD fixed-point operations using the 64-bit General Purpose Register file
- Embedded Floating-Point (EFP2) APU supporting scalar and vector SIMD single-precision floating-point operations, using the 64-bit General Purpose Register file
- Power management
 - Low power design – extensive clock gating
 - Power saving modes: wait
 - Dynamic power management of execution units, cache and MMU
- Testability
 - Synthesizeable, MuxD scan design
 - ABIST/MBIST for arrays
 - Built-in Parallel Signature Unit

- Calibration support allowing an external tool to modify address mapping

1.5.2 Crossbar switch (XBAR)

The XBAR multiport crossbar switch supports simultaneous connections between four master ports and four slave ports. The crossbar supports a 32-bit address bus width and a 64-bit data bus width.

The crossbar allows three concurrent transactions to occur from the master ports to any slave port but each master must access a different slave. If a slave port is simultaneously requested by more than one master port, arbitration logic selects the higher priority master and grants it ownership of the slave port. All other masters requesting that slave port are stalled until the higher priority master completes its transactions. Requesting masters are treated with equal priority and are granted access to a slave port in round-robin fashion, based upon the ID of the last master to be granted access. The crossbar provides the following features:

- 4 master ports
 - CPU instruction bus
 - CPU data bus
 - eDMA
 - FlexRay
- 4 slave ports
 - Flash
 - Calibration bus interface
 - SRAM
 - Peripheral bridge
- 32-bit internal address, 64-bit internal data paths

1.5.3 Enhanced direct memory access (eDMA)

The enhanced direct memory access (eDMA) controller is a second-generation module capable of performing complex data movements via 64 programmable channels, with minimal intervention from the host processor. The hardware micro-architecture includes a DMA engine which performs source and destination address calculations, and the actual data movement operations, along with an SRAM-based memory containing the transfer control descriptors (TCD) for the channels. This implementation minimizes overall block size. The eDMA module provides the following features:

- All data movement via dual-address transfers: read from source, write to destination
- Programmable source and destination addresses, transfer size, plus support for enhanced addressing modes
- Transfer control descriptor organized to support two-deep, nested transfer operations
- An inner data transfer loop defined by a “minor” byte transfer count
- An outer data transfer loop defined by a “major” iteration count
- Channel activation via one of three methods:
 - Explicit software initiation
 - Initiation via a channel-to-channel linking mechanism for continuous transfers
 - Peripheral-paced hardware requests (one per channel)
- Support for fixed-priority and round-robin channel arbitration
- Channel completion reported via optional interrupt requests
- 1 interrupt per channel, optionally asserted at completion of major iteration count
- Error termination interrupts optionally enabled
- Support for scatter/gather DMA processing
- Ability to suspend channel transfers by a higher priority channel

1.5.4 Interrupt controller (INTC)

The INTC provides priority-based preemptive scheduling of interrupt requests, suitable for statically scheduled hard real-time systems.

For high priority interrupt requests, the time from the assertion of the interrupt request from the peripheral to when the processor is executing the interrupt service routine (ISR) has been minimized. The INTC provides a unique vector for each interrupt request source for quick determination of which ISR needs to be executed. It also provides an ample number of priorities so that lower priority ISRs do not delay the execution of higher priority ISRs. To allow the appropriate priorities for each source of interrupt request, the priority of each interrupt request is software configurable.

When multiple tasks share a resource, coherent accesses to that resource need to be supported. The INTC supports the priority ceiling protocol for coherent accesses. By providing a modifiable priority mask, the priority can be raised temporarily so that all tasks which share the resource cannot preempt each other.

The INTC provides the following features:

- 9-bit vector addresses
- Unique vector for each interrupt request source
- Hardware connection to processor or read from register
- Each interrupt source can assigned a specific priority by software
- Preemptive prioritized interrupt requests to processor
- ISR at a higher priority preempts executing ISRs or tasks at lower priorities
- Automatic pushing or popping of preempted priority to or from a LIFO
- Ability to modify the ISR or task priority to implement the priority ceiling protocol for accessing shared resources
- Low latency—3 clocks from receipt of interrupt request from peripheral to interrupt request to processor

This device also includes a non-maskable interrupt (NMI) pin that bypasses the INTC and multiplexing logic.

1.5.5 Memory protection unit (MPU)

The Memory Protection Unit (MPU) provides hardware access control for all memory references generated in a device. Using preprogrammed region descriptors, which define memory spaces and their associated access rights, the MPU concurrently monitors all system bus transactions and evaluates the appropriateness of each transfer. Memory references with sufficient access control rights are allowed to complete; references that are not mapped to any region descriptor or have insufficient rights are terminated with a protection error response.

The MPU has these major features:

- Support for 16 memory region descriptors, each 128 bits in size
 - Specification of start and end addresses provide granularity for region sizes from 32 bytes to 4 GB
 - MPU is invalid at reset, thus no access restrictions are enforced
 - 2 types of access control definitions: processor core bus master supports the traditional {read, write, execute} permissions with independent definitions for supervisor and user mode accesses; the remaining non-core bus masters (eDMA, FlexRay) support {read, write} attributes
 - Automatic hardware maintenance of the region descriptor valid bit removes issues associated with maintaining a coherent image of the descriptor
 - Alternate memory view of the access control word for each descriptor provides an efficient mechanism to dynamically alter the access rights of a descriptor only
 - For overlapping region descriptors, priority is given to permission granting over access denying as this approach provides more flexibility to system software
- Support for two XBAR slave port connections (SRAM and PBRIDGE)
 - For each connected XBAR slave port (SRAM and PBRIDGE), MPU hardware monitors every port access using the preprogrammed memory region descriptors

- An access protection error is detected if a memory reference does not hit in any memory region or the reference is flagged as illegal in all memory regions where it does hit. In the event of an access error, the XBAR reference is terminated with an error response and the MPU inhibits the bus cycle being sent to the targeted slave device
- 64-bit error registers, one for each XBAR slave port, capture the last faulting address, attributes, and detail information

1.5.6 Frequency-modulated phase-locked loop (FMPLL)

The FMPLL allows the user to generate high speed system clocks from a 4 MHz to 40 MHz crystal oscillator or external clock generator. Further, the FMPLL supports programmable frequency modulation of the system clock. The PLL multiplication factor, output clock divider ratio are all software configurable. The PLL has the following major features:

- Input clock frequency from 4 MHz to 40 MHz
- Reduced frequency divider (RFD) for reduced frequency operation without forcing the PLL to relock
- 3 modes of operation
 - Bypass mode with PLL off
 - Bypass mode with PLL running (default mode out of reset)
 - PLL normal mode
- Each of the 3 modes may be run with a crystal oscillator or an external clock reference
- Programmable frequency modulation
 - Modulation enabled/disabled through software
 - Triangle wave modulation up to 100 kHz modulation frequency
 - Programmable modulation depth (0% to 2% modulation depth)
 - Programmable modulation frequency dependent on reference frequency
- Lock detect circuitry reports when the PLL has achieved frequency lock and continuously monitors lock status to report loss of lock conditions
- Clock Quality Module
 - Detects the quality of the crystal clock and causes interrupt request or system reset if error is detected
 - Detects the quality of the PLL output clock; if error detected, causes system reset or switches system clock to crystal clock and causes interrupt request
- Programmable interrupt request or system reset on loss of lock
- Self-clocked mode (SCM) operation

1.5.7 System integration unit (SIU)

The MPC5642A SIU controls MCU reset configuration, pad configuration, external interrupt, general purpose I/O (GPIO), internal peripheral multiplexing, and the system reset operation. The reset configuration block contains the external pin boot configuration logic. The pad configuration block controls the static electrical characteristics of I/O pins. The GPIO block provides uniform and discrete input/output control of the I/O pins of the MCU. The reset controller performs reset monitoring of internal and external reset sources, and drives the RSTOUT pin. Communication between the SIU and the e200z4 CPU core is via the crossbar switch. The SIU provides the following features:

- System configuration
 - MCU reset configuration via external pins
 - Pad configuration control for each pad
 - Pad configuration control for virtual I/O via DSPI serialization
- System reset monitoring and generation
 - Power-on reset support
 - Reset status register provides last reset source to software

- Glitch detection on reset input
- Software controlled reset assertion
- External interrupt
 - Rising or falling edge event detection
 - Programmable digital filter for glitch rejection
 - Critical Interrupt request
 - Non-Maskable Interrupt request
- GPIO
 - Centralized control of I/O and bus pins
 - Virtual GPIO via DSPI serialization (requires external deserialization device)
 - Dedicated input and output registers for setting each GPIO and Virtual GPIO pin
- Internal multiplexing
 - Allows serial and parallel chaining of DSPIs
 - Allows flexible selection of eQADC trigger inputs
 - Allows selection of interrupt requests between external pins and DSPI
 - From a set of eTPU output channels, allows selection of source signals for decimation filter integrators

1.5.8 Flash memory

The MPC5642A provides 2 MB of programmable, non-volatile, flash memory. The non-volatile memory (NVM) can be used to store instructions or data, or both. The flash module includes a Fetch Accelerator that optimizes the performance of the flash array to match the CPU architecture. The flash module interfaces the system bus to a dedicated flash memory array controller. For CPU ‘loads’, DMA transfers and CPU instruction fetch, it supports a 64-bit data bus width at the system bus port, and 128-bit read data interfaces to flash memory. The module contains a prefetch controller which prefetches sequential lines of data from the flash array into the buffers. Prefetch buffer hits allow no-wait responses.

The flash memory provides the following features:

- Supports a 64-bit data bus for instruction fetch, CPU loads and DMA access. Byte, halfword, word and doubleword reads are supported. Only aligned word and doubleword writes are supported.
- Fetch Accelerator
 - Architected to optimize the performance of the flash
 - Configurable read buffering and line prefetch support
 - 4-entry 128-bit wide line read buffer
 - Prefetch controller
- Hardware and software configurable read and write access protections on a per-master basis
- Interface to the flash array controller pipelined with a depth of one, allowing overlapped accesses to proceed in parallel for pipelined flash array designs
- Configurable access timing usable in a wide range of system frequencies
- Multiple-mapping support and mapping-based block access timing (0–31 additional cycles) usable for emulation of other memory types
- Software programmable block program/erase restriction control
- Erase of selected block(s)
- Read page size of 128 bits (4 words)
- ECC with single-bit correction, double-bit detection
- Program page size of 128 bits (4 words) to accelerate programming
- ECC single-bit error corrections are visible to software
- Minimum program size is 2 consecutive 32-bit words, aligned on a 0-modulo-8 byte address, due to ECC

Introduction

- Embedded hardware program and erase algorithm
- Erase suspend, program suspend and erase-suspended program
- Shadow information stored in non-volatile shadow block
- Independent program/erase of the shadow block

1.5.9 Static random access memory (SRAM)

The SRAM provides 128 KB of general purpose system SRAM. The first 32 KB block of the SRAM is powered by its own power supply pin only during standby operation.

The SRAM controller includes these features:

- 128 KB data RAM implemented as eight 16 KB (2048 × 78 bits) blocks
- Each 16 KB block has 2 rows repairable (RAMs with internal repair feature)
- Supports read/write accesses mapped to the SRAM memory from any master
- 32 KB block powered by separate supply for standby operation
- Byte, halfword, word and doubleword addressable
- ECC performs single bit correction, double bit detection

1.5.10 Boot assist module (BAM)

The BAM is a block of read-only memory that is programmed once by Freescale and is identical for all MPC5642A MCUs. The BAM program is executed every time the MCU is powered on or reset in normal mode. The BAM supports different modes of booting. They are:

- Booting from internal flash memory
- Serial boot loading (boot code is downloaded into RAM via eSCI or the FlexCAN and then executed)

The BAM also reads the reset configuration half word (RCHW) from internal flash memory and configures the MPC5642A hardware accordingly. The BAM provides the following features:

- Sets up MMU to cover all resources and mapping of all physical addresses to logical addresses with minimum address translation
- Sets up MMU to allow user boot code to execute as either Power Architecture technology code (default) or as Freescale VLE code
- Location and detection of user boot code
- Automatic switch to serial boot mode if internal flash is blank or invalid
- Supports user programmable 64-bit password protection for serial boot mode
- Supports serial bootloading via FlexCAN bus and eSCI using Freescale protocol
- Supports serial bootloading via FlexCAN bus and eSCI with auto baud rate sensing
- Supports serial bootloading of either Power Architecture technology code (default) or Freescale VLE code
- Supports booting from calibration bus interface
- Supports censorship protection for internal flash memory
- Provides an option to enable the core watchdog timer
- Provides an option to disable the system watchdog timer

1.5.11 Enhanced modular input/output system (eMIOS)

The eMIOS timer module provides the capability to generate or measure events in hardware.

The eMIOS module features include:

- Twenty-four 24-bit wide channels

- 3 channels' internal timebases sharable between channels
- 1 timebase from eTPU2 can be imported and used by the channels
- Global enable feature for all eMIOS and eTPU timebases
- Dedicated pin for each channel (not available on all package types)
- Each channel (0–23) supports the following functions:
 - General Purpose Input/Output (GPIO)
 - Single Action Input Capture (SAIC)
 - Single Action Output Compare (SAOC)
 - Output Pulse Width Modulation Buffered (OPWMB)
 - Input Period Measurement (IPM)
 - Input Pulse Width Measurement (IPWM)
 - Double Action Output Compare (DOAC)
 - Modulus Counter Buffered (MCB)
 - Output Pulse Width & Frequency Modulation Buffered (OPWFMB)
- Each channel has its own pin (not available on all package types)

1.5.12 Second generation enhanced time processing unit (eTPU2)

The eTPU2 is an enhanced co-processor designed for timing control. Operating in parallel with the host CPU, the eTPU2 processes instructions and real-time input events, performs output waveform generation, and accesses shared data without host intervention. Consequently, for each timer event, the host CPU setup and service times are minimized or eliminated. A powerful timer subsystem is formed by combining the eTPU2 with its own instruction and data RAM. High-level assembler/compiler and documentation allows customers to develop their own functions on the eTPU2.

MPC5642A devices feature the second generation of the eTPU, called eTPU2. Enhancements of the eTPU2 over the standard eTPU include:

- The Timer Counter (TCR1), channel logic and digital filters (both channel and the external timer clock input [TCRCLK]) now have an option to run at full system clock speed or system clock / 2.
- Channels support unordered transitions: transition 2 can now be detected before transition 1. Related to this enhancement, the transition detection latches (TDL1 and TDL2) can now be independently negated by microcode.
- A new User Programmable Channel Mode has been added: the blocking, enabling, service request and capture characteristics of this channel mode can be programmed via microcode.
- Microinstructions now provide an option to issue Interrupt and Data Transfer requests selected by channel. They can also be requested simultaneously at the same instruction.
- Channel Flags 0 and 1 can now be tested for branching, in addition to selecting the entry point.
- Channel digital filters can be bypassed.

The eTPU2 includes these distinctive features:

- 32 channels; each channel associated with one input and one output signal
 - Enhanced input digital filters on the input pins for improved noise immunity
 - Identical, orthogonal channels: each channel can perform any time function. Each time function can be assigned to more than one channel at a given time, so each signal can have any functionality.
 - Each channel has an event mechanism which supports single and double action functionality in various combinations. It includes two 24-bit capture registers, two 24-bit match registers, 24-bit greater-equal and equal-only comparators.
 - Input and output signal states visible from the host
- 2 independent 24-bit time bases for channel synchronization:
 - First time base clocked by system clock with programmable prescale division from 2 to 512 (in steps of 2), or by output of second time base prescaler

- Second time base counter can work as a continuous angle counter, enabling angle based applications to match angle instead of time
- Both time bases can be exported to the eMIOS timer module
- Both time bases visible from the host
- Event-triggered microengine:
 - Fixed-length instruction execution in two-system-clock microcycle
 - 14 KB of code memory (SCM)
 - 3 KB of parameter (data) RAM (SPRAM)
 - Parallel execution of data memory, ALU, channel control and flow control sub-instructions in selected combinations
 - 32-bit microengine registers and 24-bit wide ALU, with 1 microcycle addition and subtraction, absolute value, bitwise logical operations on 24-bit, 16-bit, or byte operands, single-bit manipulation, shift operations, sign extension and conditional execution
 - Additional 24-bit Multiply/MAC/Divide unit which supports all signed/unsigned Multiply/MAC combinations, and unsigned 24-bit divide. The MAC/Divide unit works in parallel with the regular microcode commands.
- Resource sharing features support channel use of common channel registers, memory and microengine time:
 - Hardware scheduler works as a “task management” unit, dispatching event service routines by predefined, host-configured priority
 - Automatic channel context switch when a “task switch” occurs, that is, one function thread ends and another begins to service a request from other channel: channel-specific registers, flags and parameter base address are automatically loaded for the next serviced channel
 - SPRAM shared between host CPU and eTPU2, supporting communication either between channels and host or inter-channel
 - Hardware implementation of 4 semaphores support coherent parameter sharing between both eTPU engines
 - Dual-parameter coherency hardware support allows atomic access to 2 parameters by host
- Test and development support features:
 - Nexus Class 1 debug, supporting single-step execution, arbitrary microinstruction execution, hardware breakpoints and watchpoints on several conditions
 - Software breakpoints
 - SCM continuous signature-check built-in self test MISC (multiple input signature calculator), runs concurrently with eTPU2 normal operation

1.5.13 Reaction module (REACM)

The REACM provides the ability to modulate output signals to manage closed loop control without CPU assistance. It works in conjunction with the eQADC and eTPU2 to increase system performance by removing the CPU from the current control loop.

The REACM has the following features:

- 6 reaction channels with peak and hold control blocks
- Each channel output is a bus of 3 signals, providing ability to control 3 inputs.
- Each channel can implement a peak and hold waveform, making it possible to implement up to six independent peak and hold control channels

Target applications include solenoid control for direct injection systems and valve control in automatic transmissions.

1.5.14 Enhanced queued analog-to-digital converter (eQADC)

The eQADC block provides accurate and fast conversions for a wide range of applications. The eQADC provides a parallel interface to two on-chip analog-to-digital converters (ADC), and a single master to single slave serial interface to an off-chip external device. Both on-chip ADCs have access to all the analog channels.

The eQADC prioritizes and transfers commands from six command conversion command ‘queues’ to the on-chip ADCs or to the external device. The block can also receive data from the on-chip ADCs or from an off-chip external device into the six result queues, in parallel, independently of the command queues. The six command queues are prioritized with Queue_0 having the highest priority and Queue_5 the lowest. Queue_0 also has the added ability to bypass all buffering and queuing and abort a currently running conversion on either ADC and start a Queue_0 conversion. This means that Queue_0 will always have a deterministic time from trigger to start of conversion, irrespective of what tasks the ADCs were performing when the trigger occurred. The eQADC supports software and external hardware triggers from other blocks to initiate transfers of commands from the queues to the on-chip ADCs or to the external device. It also monitors the fullness of command queues and result queues, and accordingly generates DMA or interrupt requests to control data movement between the queues and the system memory, which is external to the eQADC.

The ADCs also support features designed to allow the direct connection of high impedance acoustic sensors that might be used in a system for detecting engine knock. These features include differential inputs; integrated variable gain amplifiers for increasing the dynamic range; programmable pull-up and pull-down resistors for biasing and sensor diagnostics.

The eQADC also integrates a programmable decimation filter capable of taking in ADC conversion results at a high rate, passing them through a hardware low pass filter, then down-sampling the output of the filter and feeding the lower sample rate results to the result FIFOs. This allows the ADCs to sample the sensor at a rate high enough to avoid aliasing of out-of-band noise; while providing a reduced sample rate output to minimize the amount DSP processing bandwidth required to fully process the digitized waveform.

The eQADC provides the following features:

- Dual on-chip ADCs
 - 2×12 -bit ADC resolution
 - Programmable resolution for increased conversion speed (12-bit, 10-bit, 8-bit)
 - 12-bit conversion time – 938 ns (1M sample/s)
 - 10-bit conversion time – 813 ns (1.2M sample/s)
 - 8-bit conversion time – 688 ns (1.4M sample/s)
 - Up to 10-bit accuracy at 500K sample/s and 8-bit accuracy at 1M sample/s
 - Differential conversions
 - Single-ended signal range from 0 to 5 V
 - Sample times of 2 (default), 8, 64, or 128 ADC clock cycles
 - Provides time stamp information when requested
 - Allows time stamp information relative to eTPU clock sources, such as an angle clock
 - Parallel interface to eQADC command FIFOs (CFIFOs) and result FIFOs (RFIFOs)
 - Supports both right-justified unsigned and signed formats for conversion results
- 40 single-ended input channels, expandable to 56 channels with external multiplexers (supports 4 external 8-to-1 muxes)
- 8 channels can be used as 4 pairs of differential analog input channels
- Differential channels include variable gain amplifier for improved dynamic range ($\times 1$, $\times 2$, $\times 4$)
- Differential channels include programmable pull-up and pull-down resistors for biasing and sensor diagnostics (200 k Ω , 100 k Ω , 5 k Ω)
- Additional internal channels for monitoring voltages (such as core voltage, I/O voltage, LVI voltages, etc.) inside the device
- An internal bandgap reference to allow absolute voltage measurements
- Silicon die temperature sensor

- Provides temperature of silicon as an analog value
- Read using an internal ADC analog channel
- May be read with either ADC
- 2 decimation filters
 - Programmable decimation factor (1 to 16)
 - Selectable IIR or FIR filter
 - Up to 4th order IIR or 8th order FIR
 - Programmable coefficients
 - Saturated or non-saturated modes
 - Programmable Rounding (Convergent; Two's Complement; Truncated)
 - Prefill mode to precondition the filter before the sample window opens
 - Supports Multiple Cascading Decimation Filters to implement more complex filter designs
 - Optional Absolute Integrators on the output of Decimation Filters
- Full duplex synchronous serial interface (SSI) to an external device
 - Free-running clock for use by an external device
 - Supports a 26-bit message length
- Priority based queues
 - Supports 6 queues with fixed priority. When commands of distinct queues are bound for the same ADC, the higher priority queue is always served first
 - Queue_0 can bypass all prioritization, buffering and abort current conversions to start a Queue_0 conversion a deterministic time after the queue trigger
 - Supports software and hardware trigger modes to arm a particular queue
 - Generates interrupt when command coherency is not achieved
- External hardware triggers
 - Supports rising edge, falling edge, high level and low level triggers
 - Supports configurable digital filter

1.5.15 Deserial serial peripheral interface (DSPI)

The DSPI block provides a synchronous serial interface for communication between the MPC5642A MCU and external devices. The DSPI supports pin count reduction through serialization and deserialization of eTPU and eMIOS channels and memory-mapped registers. The channels and register content are transmitted using a SPI-like protocol. This SPI-like protocol is completely configurable for baud rate, polarity and phase, frame length, chip select assertion, etc. Each bit in the frame may be configured to serialize either eTPU channels, eMIOS channels or GPIO signals. The DSPI can be configured to serialize data to an external device that implements the Microsecond Bus protocol. There are three identical DSPI blocks on the MPC5642A MCU. The DSPI pins support 5 V logic levels or Low Voltage Differential Signalling (LVDS) to improve high speed operation.

DSPI module features include:

- Selectable LVDS pads working at 40 MHz for SOUT and SCK pins for DSPI_B and DSPI_C
- Support for downstream Micro Second Channel (MSC) with Timed Serial Bus (TSB) configuration on DSPI_B and DSPI_C
- 3 sources of serialized data: eTPU_A, eMIOS output channels, and memory-mapped register in the DSPI
- 4 destinations for deserialized data: eTPU_A and eMIOS input channels, SIU external Interrupt input request, memory-mapped register in the DSPI
- 32-bit DSI and TSB modes require 32 PCR registers, 32 GPO and GPI registers in the SIU to select either GPIO, eTPU or eMIOS bits for serialization
- The DSPI module can generate and check parity in a serial frame

1.5.16 Enhanced serial communications interface (eSCI)

Three eSCI modules provide asynchronous serial communications with peripheral devices and other MCUs, and include support to interface to Local Interconnect Network (LIN) slave devices. Each eSCI block provides the following features:

- Full-duplex operation
- Standard mark/space non-return-to-zero (NRZ) format
- 13-bit baud rate selection
- Programmable 8-bit or 9-bit data format
- Programmable 12-bit or 13-bit data format for Timed Serial Bus (TSB) configuration to support the Microsecond bus standard
- Automatic parity generation
- LIN support
 - Compatible with LIN slaves from revisions 1.x and 2.0 of the LIN standard
 - Autonomous transmission of entire frames
 - Configurable to support all revisions of the LIN standard
 - Automatic parity bit generation
 - Double stop bit after bit error
 - 10- or 13-bit break support
- Separately enabled transmitter and receiver
- Programmable transmitter output parity
- 2 receiver wake-up methods:
 - Idle line wake-up
 - Address mark wake-up
- Interrupt-driven operation with flags
- Receiver framing error detection
- Hardware parity checking
- 1/16 bit-time noise detection
- DMA support for both transmit and receive data
 - Global error bit stored with receive data in system RAM to allow post processing of errors

1.5.17 Controller area network (FlexCAN)

The MPC5642A MCU includes three FlexCAN blocks. The FlexCAN module is a communication controller implementing the CAN protocol according to Bosch Specification version 2.0B. The CAN protocol was designed to be used primarily as a vehicle serial data bus, meeting the specific requirements of this field: real-time processing, reliable operation in the EMI environment of a vehicle, cost-effectiveness and required bandwidth. Each FlexCAN module contains 64 message buffers.

The FlexCAN modules provide the following features:

- Based on and including all existing features of the Freescale TouCAN module
- Full Implementation of the CAN protocol specification, Version 2.0B
 - Standard data and remote frames
 - Extended data and remote frames
 - Zero to eight bytes data length
 - Programmable bit rate up to 1 Mbit/s
- Content-related addressing
- 64 message buffers of 0 to 8 bytes data length
- Individual Rx Mask Register per message buffer

- Each message buffer configurable as Rx or Tx, all supporting standard and extended messages
- Includes 1088 bytes of embedded memory for message buffer storage
- Includes 256-byte memory for storing individual Rx mask registers
- Full-featured Rx FIFO with storage capacity for 6 frames and internal pointer handling
- Powerful Rx FIFO ID filtering, capable of matching incoming IDs against 8 extended, 16 standard or 32 partial (8 bits) IDs, with individual masking capability
- Selectable backwards compatibility with previous FlexCAN versions
- Programmable clock source to the CAN Protocol Interface, either system clock or oscillator clock
- Listen only mode capability
- Programmable loop-back mode supporting self-test operation
- 3 programmable Mask Registers
- Programmable transmit-first scheme: lowest ID, lowest buffer number or highest priority
- Time Stamp based on 16-bit free-running timer
- Global network time, synchronized by a specific message
- Maskable interrupts
- Warning interrupts when the Rx and Tx Error Counters reach 96
- Independent of the transmission medium (an external transceiver is assumed)
- Multi-master concept
- High immunity to EMI
- Short latency time due to an arbitration scheme for high-priority messages
- Low power mode, with programmable wakeup on bus activity

1.5.18 FlexRay

The MPC5642A includes one dual-channel FlexRay module that implements the FlexRay Communications System Protocol Specification, Version 2.1 Rev A. Features include:

- Single channel support
- FlexRay bus data rates of 10 Mbit/s, 8 Mbit/s, 5 Mbit/s, and 2.5 Mbit/s supported
- 128 message buffers, each configurable as:
 - Receive message buffer
 - Single-buffered transmit message buffer
 - Double-buffered transmit message buffer (combines two single-buffered message buffers)
- 2 independent receive FIFOs
 - 1 receive FIFO per channel
 - Up to 255 entries for each FIFO
- ECC support

1.5.19 System timers

The system timers include two distinct types of system timer:

- Periodic interrupts/triggers using the Periodic Interrupt Timer (PIT)
- Operating system task monitors using the System Timer Module (STM)

1.5.19.1 Periodic interrupt timer (PIT)

The PIT provides five independent timer channels, capable of producing periodic interrupts and periodic triggers. The PIT has no external input or output pins and is intended to provide system ‘tick’ signals to the operating system, as well as periodic

triggers for eQADC queues. Of the five channels in the PIT, four are clocked by the system clock and one is clocked by the crystal clock. This one channel is also referred to as Real-Time Interrupt (RTI) and is used to wake up the device from low power stop mode.

The following features are implemented in the PIT:

- 5 independent timer channels
- Each channel includes 32-bit wide down counter with automatic reload
- 4 channels clocked from system clock
- 1 channel clocked from crystal clock (wake-up timer)
- Wake-up timer remains active when System STOP mode is entered; used to restart system clock after predefined time-out period
- Each channel optionally able to generate an interrupt request or a trigger event (to trigger eQADC queues) when timer reaches zero

1.5.19.2 System timer module (STM)

The STM is designed to implement the software task monitor as defined by AUTOSAR¹. It consists of a single 32-bit counter, clocked by the system clock, and four independent timer comparators. These comparators produce a CPU interrupt when the timer exceeds the programmed value.

The following features are implemented in the STM:

- One 32-bit up counter with 8-bit prescaler
- Four 32-bit compare channels
- Independent interrupt source for each channel
- Counter can be stopped in debug mode

1.5.20 Software watchdog timer (SWT)

The SWT is a second watchdog module to complement the standard Power Architecture watchdog integrated in the CPU core. The SWT is a 32-bit modulus counter, clocked by the system clock or the crystal clock, that can provide a system reset or interrupt request when the correct software key is not written within the required time window.

The following features are implemented:

- 32-bit modulus counter
- Clocked by system clock or crystal clock
- Optional programmable watchdog window mode
- Can optionally cause system reset or interrupt request on timeout
- Reset by writing a software key to memory mapped register
- Enabled out of reset
- Configuration is protected by a software key or a write-once register

1.5.21 Cyclic redundancy check (CRC) module

The CRC computing unit is dedicated to the computation of CRC off-loading the CPU. The CRC module features:

- Support for CRC-16-CCITT (x25 protocol):
— $x^{16} + x^{12} + x^5 + 1$
- Support for CRC-32 (Ethernet protocol):
— $x^{32} + x^{26} + x^{23} + x^{22} + x^{16} + x^{12} + x^{11} + x^{10} + x^8 + x^7 + x^5 + x^4 + x^2 + x + 1$

1. AUTOSAR: AUTomotive Open System ARchitecture (see <http://www.autosar.org>)

- Zero wait states for each write/read operations to the CRC_CFG and CRC_INP registers at the maximum frequency

1.5.22 Error correction status module (ECSM)

The ECSM provides a myriad of miscellaneous control functions regarding program-visible information about the platform configuration and revision levels, a reset status register, a software watchdog timer, wakeup control for exiting sleep modes, and information on platform memory errors reported by error-correcting codes and/or generic access error information for certain processor cores.

The Error Correction Status Module supports a number of miscellaneous control functions for the platform. The ECSM includes these features:

- Registers for capturing information on platform memory errors if error-correcting codes (ECC) are implemented
- For test purposes, optional registers to specify the generation of double-bit memory errors are enabled on the MPC5642A.

The sources of the ECC errors are:

- Flash memory
- SRAM
- Peripheral RAM (FlexRay, CAN, eTPU2 parameter RAM)

1.5.23 Peripheral bridge (PBRIDGE)

The PBRIDGE implements the following features:

- Duplicated periphery
- Master access privilege level per peripheral (per master: read access enable; write access enable)
- Write buffering for peripherals
- Checker applied on PBRIDGE output toward periphery
- Byte endianness swap capability

1.5.24 Calibration bus interface

The calibration bus interface controls data transfer across the crossbar switch to/from memories or peripherals attached to the VertiCal connector in the calibration address space. The calibration bus interface is only available in the VertiCal Calibration System.

Features include:

- 3.3 V \pm 10% I/O (3.0 V to 3.6 V)
- Memory controller supports various memory types
- 16-bit data bus, up to 22-bit address bus
- Pin muxing supports 32-bit muxed bus
- Selectable drive strength
- Configurable bus speed modes
- Bus monitor
- Configurable wait states

1.5.25 Power management controller (PMC)

The PMC contains circuitry to generate the internal 3.3 V supply and to control the regulation of 1.2 V supply with an external NPN ballast transistor. It also contains low voltage inhibit (LVI) and power-on reset (POR) circuits for the 1.2 V supply, the 3.3 V supply, the 3.3 V/5 V supply of the closest I/O segment (VDDEH1), and the 5 V supply of the regulators (VDDREG).

1.5.26 Nexus port controller (NPC)

The NPC block provides real-time Nexus Class3+ development support capabilities for the MPC5642A Power Architecture technology-based MCU in compliance with the IEEE-ISTO 5001-2010 standard. MDO port widths of 4 pins and 12 pins are available in all packages.

1.5.27 JTAG controller (JTAGC)

The JTAG controller (JTAGC) block provides the means to test chip functionality and connectivity while remaining transparent to system logic when not in test mode. Testing is performed via a boundary scan technique, as defined in the IEEE 1149.1-2001 standard. All data input to and output from the JTAGC block is communicated in serial format. The JTAGC block is compliant with the IEEE 1149.1-2001 standard and supports the following features:

- IEEE 1149.1-2001 Test Access Port (TAP) interface 4 pins (TDI, TMS, TCK, and TDO)
- A 5-bit instruction register that supports the following IEEE 1149.1-2001 defined instructions:
 - BYPASS, IDCODE, EXTEST, SAMPLE, SAMPLE/PRELOAD, HIGHZ, CLAMP
- A 5-bit instruction register that supports the additional following public instructions:
 - ACCESS_AUX_TAP_NPC
 - ACCESS_AUX_TAP_ONCE
 - ACCESS_AUX_TAP_eTPU
 - ACCESS_CENSOR
- 3 test data registers to support JTAG Boundary Scan mode
 - Bypass register
 - Boundary scan register
 - Device identification register
- A TAP controller state machine that controls the operation of the data registers, instruction register and associated circuitry
- Censorship Inhibit Register
 - 64-bit Censorship password register
 - If the external tool writes a 64-bit password that matches the Serial Boot password stored in the internal flash shadow row, Censorship is disabled until the next system reset.

1.5.28 Development trigger semaphore (DTS)

MPC5642A devices include a system development feature, the Development Trigger Semaphore (DTS) module, that enables user software to signal to an external tool—by driving a persistent (affected only by reset or an external tool) signal on an external device pin—that data is available. The DTS includes a register of semaphores (32-bits) and an identification register.

There are a variety of ways this module can be used, including as a component of an external real-time data acquisition system.

2 Pinout and signal description

This section contains the pinouts for all production packages for the MPC5642A device. For pin signal descriptions, please refer to [Table 3](#)

NOTE

Any pins labeled “NC” are to be left unconnected. Any connection to an external circuit or voltage may cause unpredictable device behavior or damage.

2.1 176 LQFP pinout

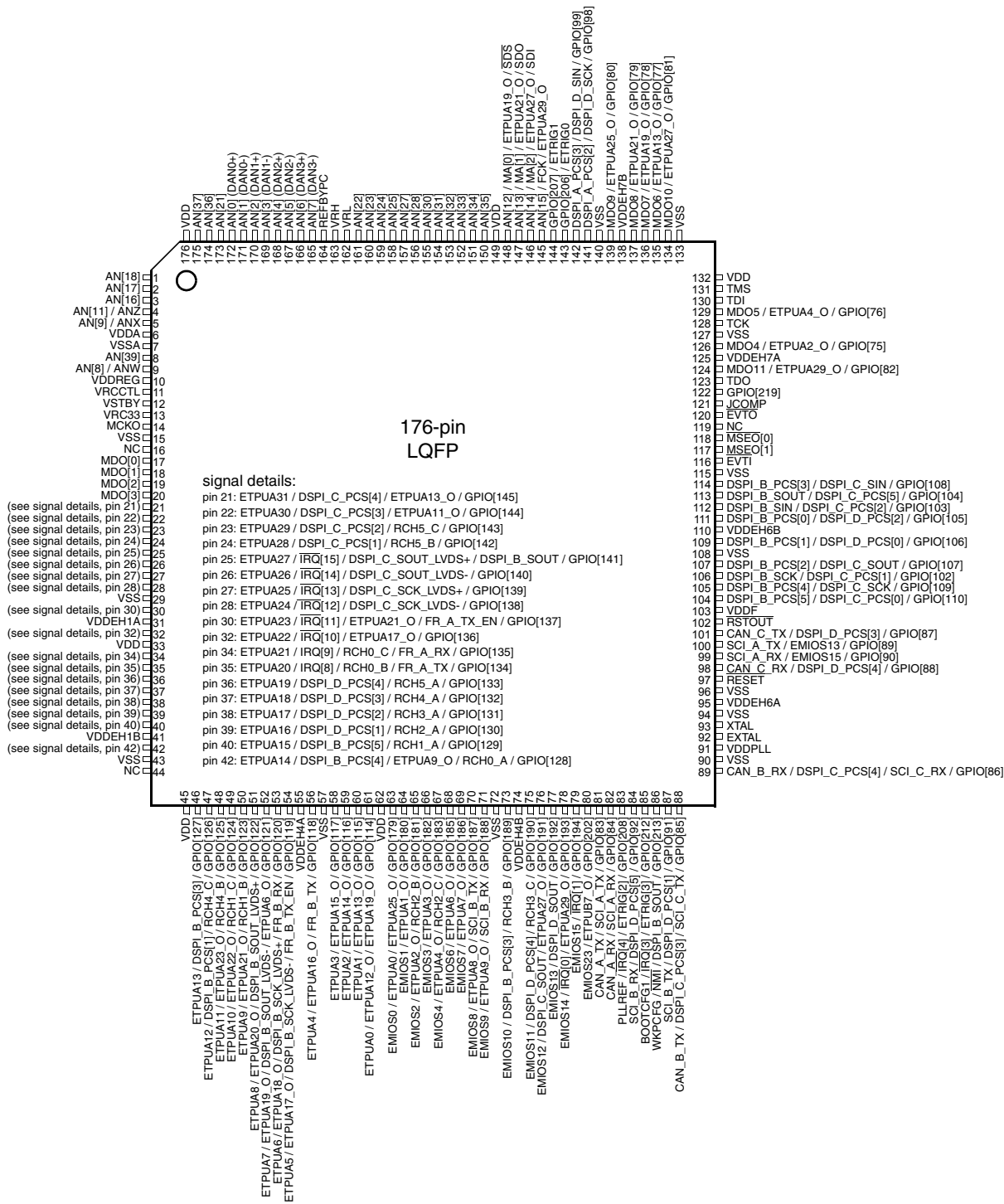

Note: Pin 96 (VSS) should be tied low.

Figure 2. 176-pin LQFP pinout (top view)

2.2 208 MAP BGA ballmap

1 2 3 4 5 6 7 8 9 10 11 12 13

A	VSS	AN9	AN11	VDDA1	VSSA1	AN1	AN5	VRH	VRL	AN27	VSSA0	AN12-SDS	MDO2
B	VDD	VSS	AN8	AN21	AN0	AN4	REFBYPC	AN22	AN25	AN28	VDDA0	AN13-SDO	MDO3
C	VSTBY	VDD	VSS	AN17	AN84	AN16	AN3	AN7	AN23	AN32	AN83	AN14-SDI	AN15-FCK
D	VRC33	AN39	VDD	VSS	AN18	AN2	AN6	AN24	AN30	AN31	AN85	VDDEH7	VSS
E	ETPUA30	ETPUA31	AN37	VDD									NC
F	ETPUA28	ETPUA29	ETPUA26	AN36									VDDEH6AB
G	ETPUA24	ETPUA27	ETPUA25	ETPUA21			VSS	VSS	VSS	VSS			DSPLB_SOUT
H	ETPUA23	ETPUA22	ETPUA17	ETPUA18			VSS	VSS	VSS	VSS			GPIO[9]
J	ETPUA20	ETPUA19	ETPUA14	ETPUA13			VSS	VSS	VSS	VSS			DSPLB_PCS[5]
K	ETPUA16	ETPUA15	ETPUA7	VDDEH1AB			VSS	VSS	VSS	VSS			CAN_C_TX
L	ETPUA12	ETPUA11	ETPUA6	TORCLKA									SCI_B_TX
M	ETPUA10	ETPUA9	ETPUA1	ETPUA5									SCI_B_RX
N	ETPUA8	ETPUA4	ETPUA0	VSS	VDD	VRC33	EMIOS2	EMIOS10	VDDEH4AB	EMIOS12	MDO7_ETPUA19_O	VRC33	VSS
P	ETPUA3	ETPUA2	VSS	VDD	GPIO[207]	NC	EMIOS6	EMIOS8	MDO11_ETPUA29_O	MDO4_ETPUA2_O	MDO8_ETPUA21_O	CAN_A_TX	VDD
R	NC	VSS	VDD	GPIO[206]	EMIOS4	EMIOS3	EMIOS9	EMIOS11	EMIOS14	MDO10_ETPUA27_O	EMIOS23	CAN_A_RX	CAN_B_RX
T	VSS	VDD	NC	EMIOS0	EMIOS1	GPIO[219]	MDO9_ETPUA25_O	EMIOS13	EMIOS15	MDO5_ETPUA4_O	MDO6_ETPUA13_O	CAN_B_TX	VDDE12
1		2	3	4	5	6	7	8	9	10	11	12	13

Figure 3. 208-pin MAPBGA package ballmap (viewed from above)

2.3 324 TEPBGA ballmap

	1	2	3	4	5	6	7	8	9	10	11
A	VSS	VDD	AN16	AN17	AN37	VDDA1	VSSA1	AN23	AN25	VRH	VRL
B	VRC33	VSS	VDD	AN18	AN36	AN21	AN4	AN5	AN24	REFBYPC	AN30
C	AN11	AN9	VSS	VDD	AN20	AN0	AN1	AN6	AN7	AN27	AN29
D	AN10	AN39	AN38	VSS	VDD	AN19	AN2	AN3	AN22	AN26	AN28
E	AN8	VSSA0	VDDA0	VSTBY							
F	MCKO	VRCCTL	MDO0	VDDREG							
G	NC	MDO1	MDO2	MDO3							
H	NC	NC	NC	NC							
J	NC	NC	NC	NC					VSS	VSS	VSS
K	ETPUA31	NC	NC	VDDEH1AB					VSS	VSS	VSS
L	ETPUA27	ETPUA26	ETPUA29	ETPUA30					VSS	VSS	VSS

Figure 4. 324-pin TEPBGA package ballmap (northwest, viewed from above)

Pinout and signal description

12	13	14	15	16	17	18	19	20	21	22		
AN34	AN14-SDI	AN15-FCK	GPIO[203]	DSPI_A_PCS[5]	DSPI_A_SOUT	MDO8_ETPUA21_O	MDO10_ETPUA27_O	VDD	VDD	VSS	A	
AN33	AN13-SDO	GPIO[207]	GPIO[99]	DSPI_A_PCS[4]	DSPI_A_SIN	MDO7_ETPUA19_O	MDO4_ETPUA2_O	MDO5_ETPUA4_O	VSS	VDDEH7	B	
AN32	AN12-SDS	GPIO[206]	GPIO[98]	DSPI_A_PCS[1]	DSPI_A_SCK	MDO6_ETPUA13_O	MDO11_ETPUA29_O	VSS	VDDEH7	VDD	C	
AN31	AN35	GPIO[204]	VDDEH7	DSPI_A_PCS[0]	VSS	MDO9_ETPUA25_O	VSS	VDDEH7	TCK	TDI	D	
								VDDEH7	TMS	TDO	NC	E
								VDDEH7	JCOMP	VSS	NC	F
								RDY	EVTO	MSE00	MSE01	G
								VDDEH7	EVTI	VSS	DSPI_B_SIN	H
								DSPI_B_SOUT	DSPI_B_PCS[3]	DSPI_B_PCS[0]	DSPI_B_PCS[1]	J
								NC	DSPI_B_PCS[4]	DSPI_B_SCK	DSPI_B_PCS[2]	K
								DSPI_B_PCS[5]	NC	VSS	NC	L

VSS	VSS	VDDEH7
VSS	VSS	VSS
VSS	VSS	VSS

Figure 6. 324-pin TEPBGA package ballmap (northeast, viewed from above)

VSS	VSS	VSS						VRC33	NC	NC	VDDEH6AB	M
VSS	VSS	VSS						NC	SCI_A_TX	VSS	NC	N
VSS	VSS	VSS						CAN_C_TX	SCI_A_RX	RSTOUT	RSTCFG	P
								NC	NC	NC	RESET	R
								VSS	BOOTCFG0	VSS	VSS	T
								VDDEH6AB	PLLCFG1	BOOTCFG1	EXTAL	U
								SCI_C_RX	CAN_C_RX	PLLREF	XTAL	V
ETPUA1	EMIOS1	VDDEH4AB	EMIOS8	EMIOS15	EMIOS16	EMIOS23	SCI_C_TX	VDD	CAN_B_RX	VDDPLL		W
ETPUA0	EMIOS2	EMIOS5	EMIOS9	EMIOS14	EMIOS17	EMIOS22	CAN_A_RX	VSS	VDD	CAN_B_TX		Y
EMIOS0	EMIOS3	EMIOS6	EMIOS10	EMIOS13	EMIOS18	EMIOS21	VDDEH4AB	WKPCFG	VSS	VDD		AA
TCRCLKA	EMIOS4	EMIOS7	EMIOS11	EMIOS12	EMIOS19	EMIOS20	CAN_A_TX	SCI_B_RX	SCI_B_TX	VSS		AB
12	13	14	15	16	17	18	19	20	21	22		

Figure 7. 324-pin TEPBGA package ballmap (southeast, viewed from above)

2.4 Signal summary

Table 3. MPC5642A signal properties

Name ¹	Function ²	P / A / G ³	PCR PA field ⁴	PCR ⁵	I/O type	Voltage ⁶ / Pad type ⁷	Status ⁸	
							During reset	After reset
GPIO								
FR_A_TX GPIO[12]	FlexRay transmit data channel A	A1 G	010 000	12	O I/O	VDDE-EH / Medium	— / Up	— / Up
FR_A_TX_EN GPIO[13]	FlexRay ch. A tx data enable	A1 G	010 000	13	O I/O	VDDE-EH / Medium	— / Up	— / Up
FR_A_RX GPIO[14]	FlexRay receive data ch. A	A1 G	010 000	14	I I/O	VDDE-EH / Medium	— / Up	— / Up
FR_B_TX GPIO[15]	FlexRay transmit data ch. B	A1 G	010 000	15	O I/O	VDDE-EH / Medium	— / Up	— / Up
FR_B_TX_EN GPIO[16]	FlexRay tx data enable for ch. B	A1 G	010 000	16	O I/O	VDDE-EH / Medium	— / Up	— / Up
FR_B_RX GPIO[17]	FlexRay receive data channel B	A1 G	010 000	17	I I/O	VDDE-EH / Medium	— / Up	— / Up
GPIO[206] ETRIG0	GPIO / eQADC Trigger Input	G	00	206	I/O ⁹	VDDEH7 / Slow ¹⁰	— / Up	— / Up
GPIO[207] ETRIG1	GPIO / eQADC Trigger Input	G	00	207	I/O ⁹	VDDEH7 / Slow	— / Up	— / Up
GPIO[219]	GPIO	G	000	219 ¹¹	I/O	VDDEH7 / Multiv	— / Up	— / Up
Reset / Configuration								
RESET	External Reset Input	P	—	—	I	VDDEH6 / Slow	RESET / Up	RESET / Up
RSTOUT	External Reset Output	P	01	230	O	VDDEH6 / Slow	RSTOUT / Down	RSTOUT / Down
PLLREF IRQ[4] ETRIG2 GPIO[208]	FMPLL Mode Selection External Interrupt Request eQADC Trigger Input GPIO	P A1 A2 G	001 010 100 000	208	I I I I/O	VDDEH6 / Slow	— / Up	PLLREF / Up
PLLCFG ¹² IRQ[5] DSPI_D_SOUT GPIO[209]	— External interrupt request DSPI D data output GPIO	— A1 A2 G	— 010 100 000	209	— I O I/O	VDDEH6 / Medium	— / Up	— / Up
RSTCFG GPIO[210]	RSTCFG GPIO	P G	01 00	210	I I/O	VDDEH6 / Slow	— / Down	—

Table 3. MPC5642A signal properties (continued)

Name ¹	Function ²	P / A / G ³	PCR PA field ⁴	PCR ⁵	I/O type	Voltage ⁶ / Pad type ⁷	Status ⁸	
							During reset	After reset
BOOTCFG[0] IRQ[2] GPIO[211]	Boot Config. Input External Interrupt Request GPIO	P A1 G	01 10 00	211	I I I/O	VDDEH6 / Slow	— / Down	BOOTCFG[0] / Down
BOOTCFG[1] IRQ[3] ETRIG3 GPIO[212]	Boot Config. Input External Interrupt Request eQADC Trigger Input GPIO	P A1 A2 G	001 010 100 000	212	I I I I/O	VDDEH6 / Slow	— / Down	BOOTCFG[1] / Down
WKPCFG NMI DSPI_B_SOUT GPIO[213]	Weak Pull Config. Input Non-Maskable Interrupt DSPI B data output GPIO	P A1 A2 G	001 010 100 000	213	I O O I/O	VDDEH6 / Medium	— / Up	WKPCFG / Up
Calibration Bus								
CAL_CS0	Calibration chip select	P	01	336	O	VDDE12 / Fast		— / —
CAL_CS2 CAL_ADDR[10] CAL_WE[2]/BE[2]	Calibration chip select Calibration address bus Calibration write/byte enable	P A1 A2	001 010 100	338	O I/O O	VDDE12 / Fast		— / —
CAL_CS3 CAL_ADDR[11] CAL_WE[3]/BE[3]	Calibration chip select Calibration address bus Calibration write/byte enable	P A1 A2	001 010 100	339	O I/O O	VDDE12 / Fast		— / —
CAL_ADDR[12] CAL_WE[2]/BE[2]	Calibration address bus Calibration write/byte enable	P A1	01 10	340	I/O O	VDDE12 / Fast		— / —
CAL_ADDR[13] CAL_WE[3]/BE[3]	Calibration address bus Calibration write/byte enable	P A1	01 10	340	I/O O	VDDE12 / Fast		— / —
CAL_ADDR[14] CAL_DATA[31]	Calibration address bus Calibration data bus	P A1	01 10	340	I/O I/O	VDDE12 / Fast		— / —
CAL_ADDR[15] CAL_ALE	Calibration address bus Calibration address latch enable	P A1	01 10	340	I/O O	VDDE12 / Fast		— / —
CAL_ADDR[16] CAL_DATA[16]	Calibration address bus Calibration data bus	P A1	01 10	345	I/O I/O	VDDE12 / Fast		— / —
CAL_ADDR[17] CAL_DATA[17]	Calibration address bus Calibration data bus	P A1	01 10	345	I/O I/O	VDDE12 / Fast		— / —
CAL_ADDR[18] CAL_DATA[18]	Calibration address bus Calibration data bus	P A1	01 10	345	I/O I/O	VDDE12 / Fast		— / —
CAL_ADDR[19] CAL_DATA[19]	Calibration address bus Calibration data bus	P A1	01 10	345	I/O I/O	VDDE12 / Fast		— / —
CAL_ADDR[20] CAL_DATA[20]	Calibration address bus Calibration data bus	P A1	01 10	345	I/O I/O	VDDE12 / Fast		— / —
CAL_ADDR[21] CAL_DATA[21]	Calibration address bus Calibration data bus	P A1	01 10	345	I/O I/O	VDDE12 / Fast		— / —

Table 3. MPC5642A signal properties (continued)

Name ¹	Function ²	P / A / G ³	PCR PA field ⁴	PCR ⁵	I/O type	Voltage ⁶ / Pad type ⁷	Status ⁸	
							During reset	After reset
CAL_ADDR[22] CAL_DATA[22]	Calibration address bus Calibration data bus	P A1	01 10	345	I/O I/O	VDDE12 / Fast	— / —	— / —
CAL_ADDR[23] CAL_DATA[23]	Calibration address bus Calibration data bus	P A1	01 10	345	I/O I/O	VDDE12 / Fast	— / —	— / —
CAL_ADDR[24] CAL_DATA[24]	Calibration address bus Calibration data bus	P A1	01 10	345	I/O I/O	VDDE12 / Fast	— / —	— / —
CAL_ADDR[25] CAL_DATA[25]	Calibration address bus Calibration data bus	P A1	01 10	345	I/O I/O	VDDE12 / Fast	— / —	— / —
CAL_ADDR[26] CAL_DATA[26]	Calibration address bus Calibration data bus	P A1	01 10	345	I/O I/O	VDDE12 / Fast	— / —	— / —
CAL_ADDR[27] CAL_DATA[27]	Calibration address bus Calibration data bus	P A1	01 10	345	I/O I/O	VDDE12 / Fast	— / —	— / —
CAL_ADDR[28] CAL_DATA[28]	Calibration address bus Calibration data bus	P A1	01 10	345	I/O I/O	VDDE12 / Fast	— / —	— / —
CAL_ADDR[29] CAL_DATA[29]	Calibration address bus Calibration data bus	P A1	01 10	345	I/O I/O	VDDE12 / Fast	— / —	— / —
CAL_ADDR[30] CAL_DATA[30]	Calibration address bus Calibration data bus	P A1	01 10	345	I/O I/O	VDDE12 / Fast	— / —	— / —
CAL_DATA[0]	Calibration data bus	P	01	341	I/O	VDDE12 / Fast	— / Up	— / Up
CAL_DATA[1]	Calibration data bus	P	01	341	I/O	VDDE12 / Fast	— / Up	— / Up
CAL_DATA[2]	Calibration data bus	P	01	341	I/O	VDDE12 / Fast	— / Up	— / Up
CAL_DATA[3]	Calibration data bus	P	01	341	I/O	VDDE12 / Fast	— / Up	— / Up
CAL_DATA[4]	Calibration data bus	P	01	341	I/O	VDDE12 / Fast	— / Up	— / Up
CAL_DATA[5]	Calibration data bus	P	01	341	I/O	VDDE12 / Fast	— / Up	— / Up
CAL_DATA[6]	Calibration data bus	P	01	341	I/O	VDDE12 / Fast	— / Up	— / Up
CAL_DATA[7]	Calibration data bus	P	01	341	I/O	VDDE12 / Fast	— / Up	— / Up
CAL_DATA[8]	Calibration data bus	P	01	341	I/O	VDDE12 / Fast	— / Up	— / Up
CAL_DATA[9]	Calibration data bus	P	01	341	I/O	VDDE12 / Fast	— / Up	— / Up

Table 3. MPC5642A signal properties (continued)

Name ¹	Function ²	P / A / G ³	PCR PA field ⁴	PCR ⁵	I/O type	Voltage ⁶ / Pad type ⁷	Status ⁸	
							During reset	After reset
CAL_DATA[10]	Calibration data bus	P	01	341	I/O	VDDE12 / Fast	— / Up	— / Up
CAL_DATA[11]	Calibration data bus	P	01	341	I/O	VDDE12 / Fast	— / Up	— / Up
CAL_DATA[12]	Calibration data bus	P	01	341	I/O	VDDE12 / Fast	— / Up	— / Up
CAL_DATA[13]	Calibration data bus	P	01	341	I/O	VDDE12 / Fast	— / Up	— / Up
CAL_DATA[14]	Calibration data bus	P	01	341	I/O	VDDE12 / Fast	— / Up	— / Up
CAL_DATA[15]	Calibration data bus	P	01	341	I/O	VDDE12 / Fast	— / Up	— / Up
CAL_RD_WR	Calibration data bus	P	01	342	O	VDDE12 / Fast	— / —	— / —
CAL_WE[0]	Calibration write enable	P	01	342	O	VDDE12 / Fast	— / —	— / —
CAL_WE[1]	Calibration write enable	P	01	342	O	VDDE12 / Fast	— / —	— / —
CAL_OE	Calibration output enable	P	01	342	O	VDDE12 / Fast	— / —	— / —
CAL_TS CAL_ALE	Calibration transfer start Address Latch Enable	P A1	01 10	343	O O	VDDE12 / Fast	— / —	— / —
CAL_MDO[4]	Calibration Nexus Message Data Out	P	01	—	O	VDDE12 / Fast	—	CAL_MDO[4] / —
CAL_MDO[5]	Calibration Nexus Message Data Out	P	01	—	O	VDDE12 / Fast	—	CAL_MDO[5] / —
CAL_MDO[6]	Calibration Nexus Message Data Out	P	01	—	O	VDDE12 / Fast	—	CAL_MDO[6] / —
CAL_MDO[7]	Calibration Nexus Message Data Out	P	01	—	O	VDDE12 / Fast	—	CAL_MDO[7] / —
CAL_MDO[8]	Calibration Nexus Message Data Out	P	01	—	O	VDDE12 / Fast	—	CAL_MDO[8] / —
CAL_MDO[9]	Calibration Nexus Message Data Out	P	01	—	O	VDDE12 / Fast	—	CAL_MDO[9] / —
CAL_MDO[10]	Calibration Nexus Message Data Out	P	01	—	O	VDDE12 / Fast	—	CAL_MDO[10] / —
CAL_MDO[11]	Calibration Nexus Message Data Out	P	01	—	O	VDDE12 / Fast	—	CAL_MDO[11] / —

Table 3. MPC5642A signal properties (continued)

Name ¹	Function ²	P / A / G ³	PCR PA field ⁴	PCR ⁵	I/O type	Voltage ⁶ / Pad type ⁷	Status ⁸	
							During reset	After reset
NEXUS ¹³								
EVTI	Nexus event in	P	01	231	I	VDDEH7 / Multiv	— / Up	EVTI / Up
EVT0 ^{†4}	Nexus event out	P	01	227	O	VDDEH7 / Multiv	ABR/Up	EVT0 / —
MCKO	Nexus message clock out	P	—	219 ^{†1}	O	VRC33 / Fast	—	MCKO / —
MDO[0]	Nexus message data out	P	01	220	O	VRC33 / Fast	—	MDO[0] / —
MDO[1]	Nexus message data out	P	01	221	O	VRC33 / Fast	—	MDO[1] / —
MDO[2]	Nexus message data out	P	01	222	O	VRC33 / Fast	—	MDO[2] / —
MDO[3]	Nexus message data out	P	01	223	O	VRC33 / Fast	—	MDO[3] / —
MDO[4] ETPUA2_O GPIO[75]	Nexus message data out eTPU A channel (output only) GPIO	P A1 G	01 10 00	75	O O I/O	VDDEH7 / Multiv	—	— / —
MDO[5] ETPUA4_O GPIO[76]	Nexus message data out eTPU A channel (output only) GPIO	P A1 G	01 10 00	76	O O I/O	VDDEH7 / Multiv	—	— / —
MDO[6] ETPUA13_O GPIO[77]	Nexus message data out eTPU A channel (output only) GPIO	P A1 G	01 10 00	77	O O I/O	VDDEH7 / Multiv	—	— / —
MDO[7] ETPUA19_O GPIO[78]	Nexus message data out eTPU A channel (output only) GPIO	P A1 G	01 10 00	78	O O I/O	VDDEH7 / Multiv	—	— / —
MDO[8] ETPUA21_O GPIO[79]	Nexus message data out eTPU A channel (output only) GPIO	P A1 G	01 10 00	79	O O I/O	VDDEH7 / Multiv	—	— / —
MDO[9] ETPUA25_O PIO[80]	Nexus message data out eTPU A channel (output only) GPIO	P A1 G	01 10 00	80	O O I/O	VDDEH7 / Multiv	—	— / —
MDO[10] ETPUA27_O GPIO[81]	Nexus message data out eTPU A channel (output only) GPIO	P A1 G	01 10 00	81	O O I/O	VDDEH7 / Multiv	—	— / —
MDO[11] ETPUA29_O GPIO[82]	Nexus message data out eTPU A channel (output only) GPIO[82]	P A1 G	01 10 00	82	O O I/O	VDDEH7 / Multiv	—	— / —

Table 3. MPC5642A signal properties (continued)

Name ¹	Function ²	P / A / G ³	PCR PA field ⁴	PCR ⁵	I/O type	Voltage ⁶ / Pad type ⁷	Status ⁸	
							During reset	After reset
MSEO[0]	Nexus message start/end out	P	01	224	O	VDDEH7 / Multiv	—	MSEO[0] / —
MSEO[1]	Nexus message start/end out	P	01	225	O	VDDEH7 / Multiv	—	MSEO[1] / —
RDY	Nexus ready output	P	01	226	O	VDDEH7 / Multiv	—	—
JTAG								
TCK	JTAG test clock input	P	01	—	I	VDDEH7 / Multiv	TCK / Down	TCK / Down
TDI	JTAG test data input	P	01	232	I	VDDEH7 / Multiv	TDI / Up	TDI / Up
TDO	JTAG test data output	P	01	228	O	VDDEH7 / Multiv	TDO / Up	TDO / Up
TMS	JTAG test mode select input	P	01	—	I	VDDEH7 / Multiv	TMS / Up	TMS / Up
JCOMP	JTAG TAP controller enable	P	01	—	I	VDDEH7 / Multiv	JCOMP / Down	JCOMP / Down
FlexCAN								
CAN_A_TX SCI_A_TX GPIO[83]	FlexCAN A transmit eSCI A transmit GPIO	P A1 G	01 10 00	83	O O I/O	VDDEH6 / Slow	— / Up	— / Up
CAN_A_RX SCI_A_RX GPIO[84]	FlexCAN A receive eSCI A receive GPIO	P A1 G	01 10 00	84	I I I/O	VDDEH6 / Slow	— / Up	— / Up
CAN_B_TX DSP1_C_PCS[3] SCI_C_TX GPIO[85]	FlexCAN B transmit DSP1 C peripheral chip select eSCI C transmit GPIO	P A1 A2 G	001 010 100 000	85	O O O I/O	VDDEH6 / Slow	— / Up	— / Up
CAN_B_RX DSP1_C_PCS[4] SCI_C_RX GPIO[86]	FlexCAN B receive DSP1 C peripheral chip select eSCI C receive GPIO	P A1 A2 G	001 010 100 000	86	I O I I/O	VDDEH6 / Slow	— / Up	— / Up
CAN_C_TX DSP1_D_PCS[3] GPIO[87]	FlexCAN C transmit DSP1 D peripheral chip select GPIO	P A1 G	01 10 00	87	O O I/O	VDDEH6 / Medium	— / Up	— / Up
CAN_C_RX DSP1_D_PCS[4] GPIO[88]	FlexCAN C receive DSP1 D peripheral chip select GPIO	P A1 G	01 10 00	88	I O I/O	VDDEH6 / Slow	— / Up	— / Up
eSCI								

Table 3. MPC5642A signal properties (continued)

Name ¹	Function ²	P / A / G ³	PCR PA field ⁴	PCR ⁵	I/O type	Voltage ⁶ / Pad type ⁷	Status ⁸	
							During reset	After reset
SCI_A_TX EMIOS13 ¹⁵ GPIO[89]	eSCI A transmit EMIOS channel GPIO	P A1 G	01 10 00	89	O O I/O	VDDEH6 / Medium	— / Up	— / Up
SCI_A_RX EMIOS15 ¹⁵ GPIO[90]	eSCI A receive EMIOS channel GPIO	P A1 G	01 10 00	90	I O I/O	VDDEH6 / Medium	— / Up	— / Up
SCI_B_TX DSP1_D_PCS[1] GPIO[91]	eSCI B transmit DSP1 D peripheral chip select GPIO	P A1 G	01 10 00	91	O O I/O	VDDEH6 / Medium	— / Up	— / Up
SCI_B_RX DSP1_D_PCS[5] GPIO[92]	eSCI B receive DSP1 D peripheral chip select GPIO	P A1 G	01 10 00	92	I O I/O	VDDEH6 / Medium	— / Up	— / Up
SCI_C_TX GPIO[244]	eSCI C transmit GPIO	P G	01 00	244	O I/O	VDDEH6 / Medium	— / Up	— / Up
SCI_C_RX GPIO[245]	eSCI C receive GPIO	P G	01 00	245	I I/O	VDDEH6 / Medium	— / Up	— / Up
DSPI								
DSPI_A_SCK ¹⁶ DSP1_C_PCS[1] GPIO[93]	— DSPI C peripheral chip select GPIO	— A1 G	— 10 00	93	— O I/O	VDDEH7 / Medium	— / Up	— / Up
DSPI_A_SIN ¹⁶ DSP1_C_PCS[2] GPIO[94]	— DSPI C peripheral chip select GPIO	— A1 G	— 10 00	94	— O I/O	VDDEH7 / Medium	— / Up	— / Up
DSPI_A_SOUT ¹⁶ DSP1_C_PCS[5] GPIO[95]	— DSPI C peripheral chip select GPIO	— A1 G	— 10 00	95	— O I/O	VDDEH7 / Medium	— / Up	— / Up
DSPI_A_PCS[0] ¹⁶ DSP1_D_PCS[2] GPIO[96]	— DSPI C peripheral chip select GPIO	— A1 G	— 10 00	96	— O I/O	VDDEH7 / Medium	— / Up	— / Up
DSPI_A_PCS[1] ¹⁶ DSP1_B_PCS[2] GPIO[97]	— DSPI C peripheral chip select GPIO	— A1 G	— 10 00	97	— O I/O	VDDEH7 / Medium	— / Up	— / Up
DSPI_A_PCS[2] ¹⁶ DSP1_D_SCK GPIO[98]	— SPI clock pin for DSPI module GPIO	— A1 G	— 10 00	98	— I/O I/O	VDDEH7 / Medium	— / Up	— / Up
DSPI_A_PCS[3] ¹⁶ DSP1_D_SIN GPIO[99]	— DSPI D data input GPIO	— A1 G	— 10 00	99	— I I/O	VDDEH7 / Medium	— / Up	— / Up
DSPI_A_PCS[4] ¹⁶ DSP1_D_SOUT GPIO[100]	— DSPI D data output GPIO	— A1 G	— 10 00	100	— O I/O	VDDEH7 / Medium	— / Up	— / Up

Table 3. MPC5642A signal properties (continued)

Name ¹	Function ²	P / A / G ³	PCR PA field ⁴	PCR ⁵	I/O type	Voltage ⁶ / Pad type ⁷	Status ⁸	
							During reset	After reset
DSP1_A_PCS[5] ¹⁶ DSP1_B_PCS[3] GPIO[101]	— DSP1 B peripheral chip select GPIO	— A1 G	— 10 00	101	— O I/O	VDDEH7 / Medium	— / Up	— / Up
DSP1_B_SCK DSP1_C_PCS[1] GPIO[102]	SPI clock pin for DSP1 module DSP1 B peripheral chip select GPIO	P A1 G	01 10 00	102	I/O O I/O	VDDEH6 / Medium	— / Up	— / Up
DSP1_B_SIN DSP1_C_PCS[2] GPIO[103]	DSP1 B data input DSP1 C peripheral chip select GPIO	P A1 G	01 10 00	103	I O I/O	VDDEH6 / Medium	— / Up	— / Up
DSP1_B_SOUT DSP1_C_PCS[5] GPIO[104]	DSP1 B data output DSP1 C peripheral chip select GPIO	P A1 G	01 10 00	104	O O I/O	VDDEH6 / Medium	— / Up	— / Up
DSP1_B_PCS[0] DSP1_D_PCS[2] GPIO[105]	DSP1 B peripheral chip select DSP1 D peripheral chip select GPIO	P A1 G	01 10 00	105	I/O O I/O	VDDEH6 / Medium	— / Up	— / Up
DSP1_B_PCS[1] DSP1_D_PCS[0] GPIO[106]	DSP1 B peripheral chip select DSP1 D peripheral chip select GPIO	P A1 G	01 10 00	106	O I/O I/O	VDDEH6 / Medium	— / Up	— / Up
DSP1_B_PCS[2] DSP1_C_SOUT GPIO[107]	DSP1 B peripheral chip select DSP1 C data output GPIO	P A1 G	01 10 00	107	O O I/O	VDDEH6 / Medium	— / Up	— / Up
DSP1_B_PCS[3] DSP1_C_SIN GPIO[108]	DSP1 B peripheral chip select DSP1 C data input GPIO	P A1 G	01 10 00	108	O I I/O	VDDEH6 / Medium	— / Up	— / Up
DSP1_B_PCS[4] DSP1_C_SCK GPIO[109]	DSP1 B peripheral chip select SPI clock pin for DSP1 module GPIO	P A1 G	01 10 00	109	O I/O I/O	VDDEH6 / Medium	— / Up	— / Up
DSP1_B_PCS[5] DSP1_C_PCS[0] GPIO[110]	DSP1 B peripheral chip select DSP1 C peripheral chip select GPIO	P A1 G	01 10 00	110	O I/O I/O	VDDEH6 / Medium	— / Up	— / Up
eQADC								
AN0 DAN0+	Single Ended Analog Input Positive Terminal Differential Input	P	—	—	I	VDDA / Analog Pull-up/down	I / —	AN[0] / —
AN1 DAN0–	Single Ended Analog Input Negative Terminal Differential Input	P	—	—	I	VDDA / Analog Pull-up/down	I / —	AN[1] / —
AN2 DAN1+	Single Ended Analog Input Positive Terminal Differential Input	P	—	—	I	VDDA / Analog Pull-up/down	I / —	AN[2] / —

Table 3. MPC5642A signal properties (continued)

Name ¹	Function ²	P / A / G ³	PCR PA field ⁴	PCR ⁵	I/O type	Voltage ⁶ / Pad type ⁷	Status ⁸	
							During reset	After reset
AN3 DAN1-	Single Ended Analog Input Negative Terminal Differential Input	P	—	—	I	VDDA / Analog Pull-up/down	I / —	AN[3] / —
AN4 DAN2+	Single Ended Analog Input Positive Terminal Differential Input	P	—	—	I	VDDA / Analog Pull-up/down	I / —	AN[4] / —
AN5 DAN2-	Single Ended Analog Input Negative Terminal Differential Input	P	—	—	I	VDDA / Analog Pull-up/down	I / —	AN[5] / —
AN6 DAN3+	Single Ended Analog Input Positive Terminal Differential Input	P	—	—	I	VDDA / Analog Pull-up/down	I / —	AN[6] / —
AN7 DAN3-	Single Ended Analog Input Negative Terminal Differential Input	P	—	—	I	VDDA / Analog Pull-up/down	I / —	AN[7] / —
AN8 ANW	Single-ended Analog Input Multiplexed Analog Input	P	01	—	I	VDDA / Analog	I / —	AN[8] / —
AN9 ANX	Single-ended Analog Input External Multiplexed Analog Input	P	01	—	I	VDDA / Analog	I / —	AN[9] / —
AN10 ANY	Single-ended Analog Input Multiplexed Analog Input	P	01	—	I	VDDA / Analog	I / —	AN[10] / —
AN11 ANZ	Single-ended Analog Input Multiplexed Analog Input	P	01	—	I	VDDA / Analog	I / —	AN[11] / —
AN12 - SDS MA0 ETPUA19_O SDS	Single-ended Analog Input MUX Address 0 eTPU A channel (output only) eQADC Serial Data Select	P A1 A2 G	001 010 100 000	215	I O O I/O	VDDEH7 / Medium	I / —	AN[12] / —
AN13 - SDO MA1 ETPUA21_O SDO	Single-ended Analog Input MUX Address 1 eTPU A channel (output only) eQADC Serial Data Out	P A1 A2 G	001 010 100 000	216	I O O	VDDEH7 / Medium	I / —	AN[13] / —
AN14 - SDI MA2 ETPUA27_O SDI	Single-ended Analog Input MUX Address 2 eTPU A channel (output only) eQADC Serial Data In	P A1 A2 G	001 010 100 000	217	I O O I	VDDEH7 / Medium	I / —	AN[14] / —
AN15 - FCK FCK ETPUA29_O	Single-ended Analog Input eQADC Free Running Clock eTPU A channel (output only)	P A1 A2	001 010 100	218	I O O	VDDEH7 / Medium	I / —	AN[15] / —
AN16	Single-ended Analog Input	P	—	—	I	VDDA / Analog	I / —	AN[16] / —
AN17	Single-ended Analog Input	P	—	—	I	VDDA / Analog	I / —	AN[17] / —

Table 3. MPC5642A signal properties (continued)

Name ¹	Function ²	P / A / G ³	PCR PA field ⁴	PCR ⁵	I/O type	Voltage ⁶ / Pad type ⁷	Status ⁸	
							During reset	After reset
AN18	Single-ended Analog Input	P	—	—	I	VDDA / Analog	I / —	AN[18] / —
AN19	Single-ended Analog Input	P	—	—	I	VDDA / Analog	I / —	AN[19] / —
AN20	Single-ended Analog Input	P	—	—	I	VDDA / Analog	I / —	AN[20] / —
AN21	Single-ended Analog Input	P	—	—	I	VDDA / Analog	I / —	AN[21] / —
AN22	Single-ended Analog Input	P	—	—	I	VDDA / Analog	I / —	AN[22] / —
AN23	Single-ended Analog Input	P	—	—	I	VDDA / Analog	I / —	AN[23] / —
AN24	Single-ended Analog Input	P	—	—	I	VDDA / Analog	I / —	AN[24] / —
AN25	Single-ended Analog Input	P	—	—	I	VDDA / Analog	I / —	AN[25] / —
AN26	Single-ended Analog Input	P	—	—	I	VDDA / Analog	I / —	AN[26] / —
AN27	Single-ended Analog Input	P	—	—	I	VDDA / Analog	I / —	AN[27] / —
AN28	Single-ended Analog Input	P	—	—	I	VDDA / Analog	I / —	AN[28] / —
AN29	Single-ended Analog Input	P	—	—	I	VDDA / Analog	I / —	AN[29] / —
AN30	Single-ended Analog Input	P	—	—	I	VDDA / Analog	I / —	AN[30] / —
AN31	Single-ended Analog Input	P	—	—	I	VDDA / Analog	I / —	AN[31] / —
AN32	Single-ended Analog Input	P	—	—	I	VDDA / Analog	I / —	AN[32] / —
AN33	Single-ended Analog Input	P	—	—	I	VDDA / Analog	I / —	AN[33] / —
AN34	Single-ended Analog Input	P	—	—	I	VDDA / Analog	I / —	AN[34] / —
AN35	Single-ended Analog Input	P	—	—	I	VDDA / Analog	I / —	AN[35] / —
AN36	Single-ended Analog Input	P	—	—	I	VDDA / Analog	I / —	AN[36] / —

Table 3. MPC5642A signal properties (continued)

Name ¹	Function ²	P / A / G ³	PCR PA field ⁴	PCR ⁵	I/O type	Voltage ⁶ / Pad type ⁷	Status ⁸	
							During reset	After reset
AN37	Single-ended Analog Input	P	—	—	I	VDDA / Analog	I / —	AN[37] / —
AN38	Single-ended Analog Input	P	—	—	I	VDDA / Analog	I / —	AN[38] / —
AN39	Single-ended Analog Input	P	—	—	I	VDDA / Analog	I / —	AN[39] / —
VRH	Voltage Reference High	P	—	—	I	VDDA / —	I / —	—
VRL	Voltage Reference Low	P	—	—	I	VDDA / —	I / —	—
REFBYBC	Reference Bypass Capacitor Input	P	—	—	I	VDDA / Analog	I / —	—
eTPU2								
TCRCLKA IRQ[7] GPIO[113]	eTPU A TCR clock External interrupt request GPIO	P A1 G	01 10 00	113	I I I/O	VDDEH4 / Slow	— / Up	— / Up
ETPUA0 ETPUA12_O ETPUA19_O GPIO[114]	eTPU A channel eTPU A channel (output only) eTPU A channel (output only) GPIO	P A1 A2 G	001 010 100 000	114	I/O O O I/O	VDDEH4 / Slow	— / WKPCFG	— / WKPCFG
ETPUA1 ETPUA13_O GPIO[115]	eTPU A channel eTPU A channel (output only) GPIO	P A1 G	01 10 00	115	I/O O I/O	VDDEH4 / Slow	— / WKPCFG	— / WKPCFG
ETPUA2 ETPUA14_O GPIO[116]	eTPU A channel eTPU A channel (output only) GPIO	P A1 G	01 10 00	116	I/O O I/O	VDDEH4 / Slow	— / WKPCFG	— / WKPCFG
ETPUA3 ETPUA15_O GPIO[117]	eTPU A channel eTPU A channel (output only) GPIO	P A1 G	01 10 00	117	I/O O I/O	VDDEH4 / Slow	— / WKPCFG	GPIO / WKPCFG
ETPUA4 ETPUA16_O FR_B_TX GPIO[118]	eTPU A channel eTPU A channel (output only) FlexRay transmit data channel B GPIO	P A1 A2 A3 G	0001 0010 — 1000 0000	118	I/O O — O I/O	VDDEH4 / Slow	— / WKPCFG	— / WKPCFG
ETPUA5 ETPUA17_O DSP_LB_SCK_LVDS- FR_B_TX_EN GPIO[119]	eTPU A channel eTPU A channel (output only) LVDS negative DSPi clock FlexRay tx data enable for ch. B GPIO	P A1 A2 A3 G	0001 0010 0100 1000 0000	119	I/O O O O I/O	VDDEH4 / Slow + LVDS	— / WKPCFG	— / WKPCFG

Table 3. MPC5642A signal properties (continued)

Name ¹	Function ²	P / A / G ³	PCR PA field ⁴	PCR ⁵	I/O type	Voltage ⁶ / Pad type ⁷	Status ⁸	
							During reset	After reset
ETPUA6 ETPUA18_O DSP1_B_SCK_LVDS+ FR_B_RX GPIO[120]	eTPU A channel eTPU A channel (output only) LVDS positive DSPI clock FlexRay receive data channel B GPIO	P A1 A2 A3 G	0001 0010 0100 1000 0000	120	I/O O O I I/O	VDDEH4 / Medium + LVDS	—/ WKPCFG	—/ WKPCFG
ETPUA7 ETPUA19_O DSP1_B_SOUT_LVDS- ETPUA6_O GPIO[121]	eTPU A channel eTPU A channel (output only) LVDS negative DSPI data out eTPU A channel (output only) GPIO	P A1 A2 A3 G	0001 0010 0100 1000 0000	121	I/O O O O I/O	VDDEH4 / Slow + LVDS	—/ WKPCFG	—/ WKPCFG
ETPUA8 ETPUA20_O DSP1_B_SOUT_LVDS+ GPIO[122]	eTPU A channel eTPU A channel (output only) LVDS positive DSPI data out GPIO	P A1 A2 G	001 010 100 000	122	I/O O O I/O	VDDEH4 / Slow + LVDS	—/ WKPCFG	—/ WKPCFG
ETPUA9 ETPUA21_O RCH1_B GPIO[123]	eTPU A channel eTPU A channel (output only) Reaction channel 1B GPIO	P A1 A2 G	001 010 100 000	123	I/O O O I/O	VDDEH4 / Slow	—/ WKPCFG	—/ WKPCFG
ETPUA10 ETPUA22_O RCH1_C GPIO[124]	eTPU A channel eTPU A channel (output only) Reaction channel 1C GPIO	P A1 A2 G	001 010 100 000	124	I/O O O I/O	VDDEH1 / Slow	—/ WKPCFG	—/ WKPCFG
ETPUA11 ETPUA23_O RCH4_B GPIO[125]	eTPU A channel eTPU A channel (output only) Reaction channel 4B GPIO	P A1 A2 G	001 010 100 000	125	I/O O O I/O	VDDEH1 / Slow	—/ WKPCFG	—/ WKPCFG
ETPUA12 DSP1_B_PCS[1] RCH4_C GPIO[126]	eTPU A channel DSPI B peripheral chip select Reaction channel 4C GPIO	P A1 A2 G	001 010 100 000	126	I/O O O I/O	VDDEH1 / Medium	—/ WKPCFG	—/ WKPCFG
ETPUA13 DSP1_B_PCS[3] GPIO[127]	eTPU A channel DSPI B peripheral chip select GPIO	P A1 G	01 10 00	127	I/O O I/O	VDDEH1 / Medium	—/ WKPCFG	—/ WKPCFG
ETPUA14 DSP1_B_PCS[4] ETPUA9_O RCH0_A GPIO[128]	eTPU A channel DSPI B peripheral chip select eTPU A channel (output only) Reaction channel 0A GPIO	P A1 A2 A3 G	0001 0010 0100 1000 0000	128	I/O O O O I/O	VDDEH1 / Medium	—/ WKPCFG	—/ WKPCFG
ETPUA15 DSP1_B_PCS[5] RCH1_A GPIO[129]	eTPU A channel DSPI B peripheral chip select Reaction channel 1A GPIO	P A1 A2 G	001 010 100 000	129	I/O O O I/O	VDDEH1 / Medium	—/ WKPCFG	—/ WKPCFG
ETPUA16 DSP1_D_PCS[1] RCH2_A GPIO[130]	eTPU A channel DSPI D peripheral chip select Reaction channel 2A GPIO	P A1 A2 G	001 010 100 000	130	I/O O O I/O	VDDEH1 / Slow	—/ WKPCFG	—/ WKPCFG

Table 3. MPC5642A signal properties (continued)

Name ¹	Function ²	P / A / G ³	PCR PA field ⁴	PCR ⁵	I/O type	Voltage ⁶ / Pad type ⁷	Status ⁸	
							During reset	After reset
ETPUA17 DSP1_D_PCS[2] RCH3_A GPIO[131]	eTPU A channel DSPI D peripheral chip select Reaction channel 3A GPIO	P A1 A2 G	001 010 100 000	131	I/O O O I/O	VDDEH1 / Slow	—/ WKPCFG	—/ WKPCFG
ETPUA18 DSP1_D_PCS[3] RCH4_A GPIO[132]	eTPU A channel DSPI D peripheral chip select Reaction channel 4A GPIO	P A1 A2 G	001 010 100 000	132	I/O O O I/O	VDDEH1 / Slow	—/ WKPCFG	—/ WKPCFG
ETPUA19 DSP1_D_PCS[4] RCH5_A GPIO[133]	eTPU A channel DSPI D peripheral chip select Reaction channel 5A GPIO	P A1 A2 G	001 010 100 000	133	I/O O O I/O	VDDEH1 / Slow	—/ WKPCFG	—/ WKPCFG
ETPUA20 IRQ[8] RCH0_B FR_A_TX GPIO[134]	eTPU A channel External interrupt request Reaction channel 0B FlexRay transmit data channel A GPIO	P A1 A2 A3 G	0001 0010 0100 1000 0000	134	I/O I O O I/O	VDDEH1 / Slow	—/ WKPCFG	—/ WKPCFG
ETPUA21 IRQ[9] RCH0_C FR_A_RX GPIO[135]	eTPU A channel External interrupt request Reaction channel 0C FlexRay receive channel A GPIO	P A1 A2 A3 G	0001 0010 0100 1000 0000	135	I/O I O I I/O	VDDEH1 / Slow	—/ WKPCFG	—/ WKPCFG
ETPUA22 IRQ[10] ETPUA17_O GPIO[136]	eTPU A channel External interrupt request eTPU A channel (output only) GPIO	P A1 A2 G	001 010 100 000	136	I/O I O O I/O	VDDEH1 / Slow	—/ WKPCFG	—/ WKPCFG
ETPUA23 IRQ[11] ETPUA21_O FR_A_TX_EN GPIO[137]	eTPU A channel External interrupt request eTPU A channel (output only) FlexRay ch. A transmit enable GPIO	P A1 A2 A3 G	0001 0010 0100 1000 0000	137	I/O I O O I/O	VDDEH1 / Slow	—/ WKPCFG	—/ WKPCFG
ETPUA24 IRQ[12] DSP1_C_SCK_LVDS- GPIO[138]	eTPU A channel External interrupt request LVDS negative DSPI clock GPIO	P A1 A2 G	001 010 100 000	138	I/O I O O I/O	VDDEH1 / Slow + LVDS	—/ WKPCFG	—/ WKPCFG
ETPUA25 IRQ[13] DSP1_C_SCK_LVDS+ GPIO[139]	eTPU A channel External interrupt request LVDS positive DSPI clock GPIO	P A1 A2 G	001 010 100 000	139	I/O I O O I/O	VDDEH1 / Medium + LVDS	—/ WKPCFG	—/ WKPCFG
ETPUA26 IRQ[14] DSP1_C_SOUT_LVDS- GPIO[140]	eTPU A channel External interrupt request LVDS negative DSPI data out GPIO	P A1 A2 G	001 010 100 000	140	I/O I O O I/O	VDDEH1 / Slow + LVDS	—/ WKPCFG	—/ WKPCFG

Table 3. MPC5642A signal properties (continued)

Name ¹	Function ²	P / A / G ³	PCR PA field ⁴	PCR ⁵	I/O type	Voltage ⁶ / Pad type ⁷	Status ⁸	
							During reset	After reset
ETPUA27 IRQ[15] DSP1_C_SOUT_LVDS+ DSP1_B_SOUT GPIO[141]	eTPU A channel External interrupt request LVDS positive DSP1 data out DSP1 B data output GPIO	P A1 A2 A3 G	0001 0010 0100 1000 0000	141	I/O I O O I/O	VDDEH1 / Slow + LVDS	—/ WKPCFG	—/ WKPCFG
ETPUA28 DSP1_C_PCS[1] RCH5_B GPIO[142]	eTPU A channel DSP1 C peripheral chip select Reaction channel 5B GPIO	P A1 A2 G	001 010 100 000	142	I/O O O I/O	VDDEH1 / Medium	—/ WKPCFG	—/ WKPCFG
ETPUA29 DSP1_C_PCS[2] RCH5_C GPIO[143]	eTPU A channel DSP1 C peripheral chip select Reaction channel 5C GPIO	P A1 A2 G	001 010 100 000	143	I/O O O I/O	VDDEH1 / Medium	—/ WKPCFG	—/ WKPCFG
ETPUA30 DSP1_C_PCS[3] ETPUA11_O GPIO[144]	eTPU A channel DSP1 C peripheral chip select eTPU A channel (output only) GPIO	P A1 A2 G	001 010 100 000	144	I/O O O I/O	VDDEH1 / Medium	—/ WKPCFG	—/ WKPCFG
ETPUA31 DSP1_C_PCS[4] ETPUA13_O GPIO[145]	eTPU A channel DSP1 C peripheral chip select eTPU A channel (output only) GPIO	P A1 A2 G	001 010 100 000	145	I/O O O I/O	VDDEH1 / Medium	—/ WKPCFG	—/ WKPCFG
eMIOS								
EMIOS0 ETPUA0_O ETPUA25_O GPIO[179]	eMIOS channel eTPU A channel (output only) eTPU A channel (output only) GPIO	P A1 A2 G	001 010 100 000	179	I/O O O I/O	VDDEH4 / Slow	— / Up	— / Up
EMIOS1 ETPUA1_O GPIO[180]	eMIOS channel eTPU A channel (output only) GPIO	P A1 G	01 10 00	180	I/O O I/O	VDDEH4 / Slow	— / Up	— / Up
EMIOS2 ETPUA2_O RCH2_B GPIO[181]	eMIOS channel eTPU A channel (output only) Reaction channel 2B GPIO	P A1 A2 G	001 010 100 000	181	I/O O O I/O	VDDEH4 / Slow	— / Up	— / Up
EMIOS3 ETPUA3_O GPIO[182]	eMIOS channel eTPU A channel (output only) GPIO	P A1 G	01 10 00	182	I/O O I/O	VDDEH4 / Slow	—/ WKPCFG	—/ WKPCFG
EMIOS4 ETPUA4_O RCH2_C GPIO[183]	eMIOS channel eTPU A channel (output only) Reaction channel 2C GPIO	P A1 A2 G	001 010 100 000	183	I/O O O I/O	VDDEH4 / Slow	—/ WKPCFG	—/ WKPCFG
EMIOS5 ETPUA5_O GPIO[184]	eMIOS channel eTPU A channel (output only) GPIO	P A1 G	01 10 00	184	I/O O I/O	VDDEH4 / Slow	—/ WKPCFG	—/ WKPCFG

Table 3. MPC5642A signal properties (continued)

Name ¹	Function ²	P / A / G ³	PCR PA field ⁴	PCR ⁵	I/O type	Voltage ⁶ / Pad type ⁷	Status ⁸	
							During reset	After reset
EMIOS6 eTPUA6_O GPIO[185]	eMIOS channel eTPU A channel (output only) GPIO	P A1 G	01 10 00	185	I/O O I/O	VDDEH4 / Slow	— / Down	— / Down
EMIOS7 eTPUA7_O GPIO[186]	eMIOS channel eTPU A channel (output only) GPIO	P A1 G	01 10 00	186	I/O O I/O	VDDEH4 / Slow	— / Down	— / Down
EMIOS8 eTPUA8_O SCLB_TX GPIO[187]	eMIOS channel eTPU A channel (output only) eSCI B transmit GPIO	P A1 A2 G	001 010 100 000	187	I/O O O I/O	VDDEH4 / Slow	— / Up	— / Up
EMIOS9 eTPUA9_O SCLB_RX GPIO[188]	eMIOS channel eTPU A channel (output only) eSCI B receive GPIO	P A1 A2 G	001 010 100 000	188	I/O O I I/O	VDDEH4 / Slow	— / Up	— / Up
EMIOS10 DSPID_PCS[3] RCH3_B GPIO[189]	eMIOS channel DSPI D peripheral chip select Reaction channel 3B GPIO	P A1 A2 G	001 010 100 000	189	I/O O O I/O	VDDEH4 / Medium	— / WKPCFG	— / WKPCFG
EMIOS11 DSPID_PCS[4] RCH3_C GPIO[190]	eMIOS channel DSPI D peripheral chip select Reaction channel 3C GPIO	P A1 A2 G	001 010 100 000	190	I/O O O I/O	VDDEH4 / Medium	— / WKPCFG	— / WKPCFG
EMIOS12 DSPIC_SOUT eTPUA27_O GPIO[191]	eMIOS channel DSPI C data output eTPU A channel (output only) GPIO	P A1 A2 G	001 010 100 000	191	I/O O O I/O	VDDEH4 / Medium	— / WKPCFG	— / WKPCFG
EMIOS13 DSPID_SOUT GPIO[192]	eMIOS channel DSPI D data output GPIO	P A1 G	01 10 00	192	I/O O I/O	VDDEH4 / Medium	— / WKPCFG	— / WKPCFG
EMIOS14 IRQ[0] eTPUA29_O GPIO[193]	eMIOS channel External interrupt request eTPU A channel (output only) GPIO	P A1 A2 G	001 010 100 000	193	I/O I O O I/O	VDDEH4 / Slow	— / Down	— / Down
EMIOS15 IRQ[1] GPIO[194]	eMIOS channel External interrupt request GPIO	P A1 G	01 10 00	194	I/O I I/O	VDDEH4 / Slow	— / Down	— / Down
EMIOS16 GPIO[195]	eMIOS channel GPIO	P G	01 00	195	I/O I/O	VDDEH4 / Slow	— / Up	— / Up
EMIOS17 GPIO[196]	eMIOS channel GPIO	P G	01 00	196	I/O I/O	VDDEH4 / Slow	— / Up	— / Up
EMIOS18 GPIO[197]	eMIOS channel GPIO	P G	01 00	197	I/O I/O	VDDEH4 / Slow	— / Up	— / Up
EMIOS19 GPIO[198]	eMIOS channel GPIO	P G	01 00	198	I/O I/O	VDDEH4 / Slow	— / WKPCFG	— / WKPCFG

Table 3. MPC5642A signal properties (continued)

Name ¹	Function ²	P / A / G ³	PCR PA field ⁴	PCR ⁵	I/O type	Voltage ⁶ / Pad type ⁷	Status ⁸	
							During reset	After reset
EMIOS20 GPIO[199]	eMIOS channel GPIO	P G	01 00	199	I/O I/O	VDDEH4 / Slow	— / WKPCFG	— / WKPCFG
EMIOS21 GPIO[200]	eMIOS channel GPIO	P G	01 00	200	I/O I/O	VDDEH4 / Slow	— / WKPCFG	— / WKPCFG
EMIOS22 GPIO[201]	eMIOS channel GPIO	P G	01 00	201	I/O I/O	VDDEH4 / Slow	— / Down	— / Down
EMIOS23 GPIO[202]	eMIOS channel GPIO	P G	01 00	202	I/O I/O	VDDEH4 / Slow	— / Down	— / Down
EMIOS14 ¹⁵ GPIO[203]	eMIOS channel GPIO	P G	01 00	203	O I/O	VDDEH7 / Slow	— / Down	— / Down
EMIOS15 ¹⁵ GPIO[204]	eMIOS channel GPIO	P G	01 00	204	O I/O	VDDEH7 / Slow	— / Down	— / Down
Clock Synthesizer								
XTAL	Crystal oscillator output	P	01	—	O	VDDEH6 / Analog	—	—
EXTAL	Crystal oscillator input	P	01	—	I	VDDEH6 / Analog	—	—
CLKOUT	System clock output	P	01	229	O	VDDE12 / Fast	—	CLKOUT
ENGCLK	Engineering clock output	P	01	214	O	VDDE12 / Fast	—	ENGCLK
Power / Ground								
VDDREG	Voltage regulator supply	—	—	—	I	5 V	I / —	VDDREG
VRCCTL	Voltage regulator control output	—	—	—	O	—	O / —	VRCCTL
VRC33 ¹⁷	Internal regulator output	—	—	—	O	3.3 V	I/O / —	VRC33
	Input for external 3.3 V supply	—	—	—	I	3.3 V	—	—
VDDA	eQADC high reference voltage	—	—	—	I	5 V	I / —	VDDA
VSSA	eQADC ground/low reference voltage	—	—	—	I	—	I / —	VSSA
VDDPLL	FMPLL supply voltage	—	—	—	I	1.2 V	I / —	VDDPLL
VSTBY	Power supply for standby RAM	—	—	—	I	0.9 V – 6 V	I / —	VSTBY

Table 3. MPC5642A signal properties (continued)

Name ¹	Function ²	P / A / G ³	PCR PA field ⁴	PCR ⁵	I/O type	Voltage ⁶ / Pad type ⁷	Status ⁸	
							During reset	After reset
VDD	Core supply for input or decoupling	—		—	I	1.2 V	I / —	VDD
VDDE12	External supply input for calibration bus interfaces	—		—	I	3.0 V – 3.6 V	I / —	VDDE12
VDDE5	External supply input for ENGCLK and CLKOUT	—		—	I	3.0 V – 3.6 V	I / —	VDDE5
VDDE-EH	External supply for EBI interfaces	—		—	I	3.0 V – 5.0 V	I / —	VDDE-EH
VDDEH1A ¹⁸	I/O supply input	—		—	I	3.3 V – 5.0 V	I / —	VDDEH1A ¹⁸
VDDEH1B ¹⁸	I/O supply input	—		—	I	3.3 V – 5.0 V	I / —	VDDEH1B ¹⁸
VDDEH1AB ¹⁸	I/O supply input	—		—	I	3.3 V – 5.0 V	I / —	VDDEH1AB ¹⁸
VDDEH4 ¹⁹	I/O supply input	—		—	I	3.3 V – 5.0 V	I / —	VDDEH4 ¹⁹
VDDEH4A ¹⁹	I/O supply input	—		—	I	3.3 V – 5.0 V	I / —	VDDEH4A ¹⁹
VDDEH4B ¹⁹	I/O supply input	—		—	I	3.3 V – 5.0 V	I / —	VDDEH4B ¹⁹
VDDEH4AB ¹⁹	I/O supply input	—		—	I	3.3 V – 5.0 V	I / —	VDDEH4AB ¹⁹
VDDEH6 ²⁰	I/O supply input	—		—	I	3.3 V – 5.0 V	I / —	VDDEH6 ²⁰
VDDEH6A ²⁰	I/O supply input	—		—	I	3.3 V – 5.0 V	I / —	VDDEH6A ²⁰
VDDEH6B ²⁰	I/O supply input	—		—	I	3.3 V – 5.0 V	I / —	VDDEH6B ²⁰
VDDEH6AB ²⁰	I/O supply input	—		—	I	3.3 V – 5.0 V	I / —	VDDEH6AB ²⁰

Table 3. MPC5642A signal properties (continued)

Name ¹	Function ²	P / A / G ³	PCR PA field ⁴	PCR ⁵	I/O type	Voltage ⁶ / Pad type ⁷	Status ⁸	
							During reset	After reset
VDDEH7 ²¹	I/O supply input	—	—	—	I	3.3 V – 5.0 V	I / —	VDDEH7
VDDEH7A ²¹	I/O supply input	—	—	—	I	3.3 V – 5.0 V	I / —	VDDEH7A
VDDEH7B ²¹	I/O supply input	—	—	—	I	3.3 V – 5.0 V	I / —	VDDEH7B
VSS	Ground	—	—	—	I	—	I / —	VSS

¹ The suffix “_O” identifies an output-only eTPU channel

² For each pin in the table, each line in the Function column is a separate function of the pin. For all I/O pins the selection of primary function or GPIO is done in the SIU except where explicitly noted. See the Signal details table for a description of each signal.

³ The P/A/G column indicates the position a signal occupies in the muxing order for a pin—Primary, Alternate 1, Alternate 2, Alternate 3 selected by setting the PA field value in the appropriate PCR register in the SIU module. The PA field values are as follows: P - 0b0100, A3 - 0b1000, or G - 0b0000. Depending on the register, the PA field size can vary in length. For PA fields having fewer than appropriate number of leading zeroes from these values.

⁴ The Pad Configuration Register (PCR) PA field is used by software to select pin function.

⁵ Values in the PCR column refer to registers in the System Integration Unit (SIU). The actual register name is “SIU_PCR” suffixed with the pin number. For example, PCR[190] refers to the SIU register named SIU_PCR190.

⁶ The VDDE and VDDEH supply inputs are broken into segments. Each segment of slow I/O pins (VDDEH) may have a separate supply range (–10%/+5%). Each segment of fast I/O (VDDE) may have a separate supply in the 1.8 V to 3.3 V range (+/– 10%).

- 7 See [Table 4](#) for details on pad types.
- 8 The Status During Reset pin is sampled after the internal POR is negated. Prior to exiting POR, the signal has a high impedance (input), Up (weak pull up enabled), Down (weak pull down enabled), Low (output driven low), High (output driven high). A dash denotes that both the input and output buffer are turned off. The signal name to the left or right of the slash indicates the pin is enabled when used as ETRIG, this pin must be configured as an input. For GPIO it can be configured either as an input or output. Maximum frequency is 50 kHz
- 11 PCR219 controls two different pins: MCKO and GPIO[219]. Please refer to Pad Configuration Register 219 section in SIU chapter for details.
- 12 On 176 LQFP and 208 MAPBGA packages, this pin is tied low internally.
- 13 These pins are selected by asserting JCOMP and configuring the NPC. SIU values have no effect on the function of this pin once selected.
- 14 The BAM uses this pin to select if auto baud rate is on or off.
- 15 Output only
- 16 This signal name is used to support legacy naming.
- 17 Do not use VRC33 to drive external circuits.
- 18 VDDEH1A, VDDEH1B and VDDEH1AB are shorted together in all production packages. The separation of the signal names is present in legacy naming, however they should be considered as the same signal in this document.
- 19 VDDEH4, VDDEH4A, VDDEH4B and VDDEH4AB are shorted together in all production packages. The separation of the signal names is present in legacy naming, however they should be considered as the same signal in this document.
- 20 VDDEH6, VDDEH6A, VDDEH6B and VDDEH6AB are shorted together in all production packages. The separation of the signal names is present in legacy naming, however they should be considered as the same signal in this document.
- 21 VDDEH7, VDDEH7A and VDDEH7B are shorted together in all production packages. The separation of the signal names is present in legacy naming, however they should be considered as the same signal in this document.

Table 4. Pad types

Pad Type	Name	I/O Voltage Range
Slow	pad_ssr_hv	3.0V - 5.5 V
Medium	pad_msr_hv	3.0 V - 5.5 V
Fast	pad_fc	3.0 V - 3.6 V
Multiv ^{1,2}	pad_multv_hv	3.0 V - 5.5 V (high swing mode) 3.0 V - 3.6 V (low swing mode)
Analog	pad_ae_hv	0.0 - 5.5 V
LVDS	pad_lo_lv	—

¹ Multivoltage pads are automatically configured in low swing mode when a JTAG or Nexus function is selected, otherwise they are high swing.

² VDDEH7 supply cannot be below 4.5 V when in low-swing mode.

2.5 Signal details

Table 5. Signal details

Signal	Module or function	Description
CLKOUT	Clock Generation	MPC5642A clock output for the calibration bus interface
ENGCLK	Clock Generation	Clock for external ASIC devices
EXTAL	Clock Generation	Input pin for an external crystal oscillator or an external clock source based on the value driven on the PLLREF pin at reset
PLLREF	Clock Generation Reset/Configuration	<p>PLLREF is used to select whether the oscillator operates in xtal mode or external reference mode from reset. PLLREF = 0 selects external reference mode. On the 324 TEPBGA package, PLLREF is bonded to the ball used for PLLCFG[0] for compatibility with MPC55xx devices.</p> <p>For the 176-pin QFP and 208-ball BGA packages: 0: External reference clock is selected 1: XTAL oscillator mode is selected</p> <p>For the 324-ball BGA package: If RSTCFG is 0: 0: External reference clock is selected 1: XTAL oscillator mode is selected</p> <p>If RSTCFG is 1, XTAL oscillator mode is selected.</p>
XTAL	Clock Generation	Crystal oscillator input
DSPI_B_SCK_LVDS– DSPI_B_SCK_LVDS+	DSPI	LVDS pair used for DSPI_B TSB mode transmission
DSPI_B_SOUT_LVDS– DSPI_B_SOUT_LVDS+	DSPI	LVDS pair used for DSPI_B TSB mode transmission

Table 5. Signal details (continued)

Signal	Module or function	Description
DSPI_C_SCK_LVDS- DSPI_C_SCK_LVDS+	DSPI	LVDS pair used for DSPI_C TSB mode transmission
DSPI_C_SOUT_LVDS- DSPI_C_SOUT_LVDS+	DSPI	LVDS pair used for DSPI_C TSB mode transmission
DSPI_B_PCS[0] DSPI_C_PCS[0] DSPI_D_PCS[0]	DSPI_B – DSPI_D	Peripheral chip select when device is in master mode—slave select when used in slave mode
DSPI_B_PCS[1:5] DSPI_C_PCS[1:5] DSPI_D_PCS[1:5]	DSPI_B – DSPI_D	Peripheral chip select when device is in master mode—not used in slave mode
DSPI_B_SCK DSPI_C_SCK DSPI_D_SCK	DSPI_B – DSPI_D	DSPI clock—output when device is in master mode; input when in slave mode
DSPI_B_SIN DSPI_C_SIN DSPI_D_SIN	DSPI_B – DSPI_D	DSPI data in
DSPI_B_SOUT DSPI_C_SOUT DSPI_D_SOUT	DSPI_B – DSPI_D	DSPI data out
eMIOS[0:23]	eMIOS	eMIOS I/O channels
AN[0:39]	eQADC	Single-ended analog inputs for analog-to-digital converter
AN[0:7]/DAN+	eQADC	Differential analog input pair for analog-to-digital converter with pull-up/pull-down functionality
AN[0:7]/DAN–	eQADC	Differential analog input pair for analog-to-digital converter with pull-up/pull-down functionality
FCK	eQADC	eQADC free running clock for eQADC SSI
MA[0:2]	eQADC	These three control bits are output to enable the selection for an external Analog Mux for expansion channels.
REFBYPC	eQADC	Bypass capacitor input
SDI	eQADC	Serial data in
SDO	eQADC	Serial data out
SDS	eQADC	Serial data select
VRH	eQADC	Voltage reference high input
VRL	eQADC	Voltage reference low input
SCI_A_RX SCI_B_RX SCI_C_RX	eSCI_A – eSCI_C	eSCI receive
SCI_A_TX SCI_B_TX SCI_C_TX	eSCI_A – eSCI_C	eSCI transmit
ETPU_A[0:31]	eTPU	eTPU I/O channel

Table 5. Signal details (continued)

Signal	Module or function	Description
RCH0_[A:C] RCH1_[A:C] RCH2_[A:C] RCH3_[A:C] RCH4_[A:C] RCH5_[A:C]	eTPU2 Reaction Module	eTPU2 reaction channels. Used to control external actuators, e.g., solenoid control for direct injection systems and valve control in automatic transmissions
TCRCLKA	eTPU2	Input clock for TCR time base
CAN_A_TX CAN_B_TX CAN_C_TX	FlexCAN_A – FlexCAN_C	FlexCAN transmit
CAN_A_RX CAN_B_RX CAN_C_RX	FlexCAN_A – FlexCAN_C	FlexCAN receive
FR_A_RX FR_B_RX	FlexRay	FlexRay receive (Channels A, B)
FR_A_TX_EN FR_B_TX_EN	FlexRay	FlexRay transmit enable (Channels A, B)
FR_A_TX FR_B_TX	FlexRay	FlexRay transmit (Channels A, B)
JCOMP	JTAG	Enables the JTAG TAP controller
TCK	JTAG	Clock input for the on-chip test logic
TDI	JTAG	Serial test instruction and data input for the on-chip test logic
TDO	JTAG	Serial test data output for the on-chip test logic
TMS	JTAG	Controls test mode operations for the on-chip test logic
$\overline{\text{EVTI}}$	Nexus	$\overline{\text{EVTI}}$ is an input that is read on the negation of $\overline{\text{RESET}}$ to enable or disable the Nexus Debug port. After reset, the $\overline{\text{EVTI}}$ pin is used to initiate program synchronization messages or generate a breakpoint.
$\overline{\text{EVTO}}$	Nexus	Output that provides timing to a development tool for a single watchpoint or breakpoint occurrence
MCKO	Nexus	MCKO is a free running clock output to the development tools which is used for timing of the MDO and $\overline{\text{MSEO}}$ signals.
MDO[0:11]	Nexus	Trace message output to development tools. This pin also indicates the status of the crystal oscillator clock following a power-on reset, when MDO[0] is driven high until the crystal oscillator clock achieves stability and is then negated.
$\overline{\text{MSEO}}$ [0:1]	Nexus	Output pin—Indicates the start or end of the variable length message on the MDO pins
RDY	Nexus	Nexus Ready Output (RDY)—Indicates to the development tools that data is ready to be read from or written to the Nexus read/write access registers.

Table 5. Signal details (continued)

Signal	Module or function	Description
BOOTCFG[0:1]	SIU – Configuration	<p>Two BOOTCFG signals are implemented in MPC5642A MCUs.</p> <p>The BAM program uses the BOOTCFG0 bit to determine where to read the reset configuration word, and whether to initiate a FlexCAN or eSCI boot.</p> <p>The BOOTCFG1 pin is sampled during the assertion of the RSTOUT signal, and the value is used to update the RSR and the BAM boot mode.</p> <p>See reference manual section “Reset Configuration Half Word (RCHW)” for details on the RCHW. The table “Boot Modes” in reference manual section “BAM Program Operation” defines the boot modes specified by the BOOTCFG1 pin.</p> <p>The following values are for BOOTCFG[0:1]: 00: Boot from internal flash memory 01: FlexCAN/eSCI boot 10: Boot from external memory using calibration bus 11: Reserved</p> <p>Note: For the 176-pin QFP and 208-ball BGA packages BOOTCFG[0] is always 0 since the EBI interface is not available.</p>
WKPCFG	SIU – Configuration	<p>The WKPCFG pin is applied at the assertion of the internal reset signal (assertion of $\overline{\text{RSTOUT}}$), and is sampled four clock cycles before the negation of the $\overline{\text{RSTOUT}}$ pin.</p> <p>The value is used to configure whether the eTPU and eMIOS pins are connected to internal weak pull up or weak pull down devices after reset. The value latched on the WKPCFG pin at reset is stored in the Reset Status Register (RSR), and is updated for all reset sources except the Debug Port Reset and Software External Reset.</p> <p>0: Weak pulldown applied to eTPU and eMIOS pins at reset 1: Weak pullup applied to eTPU and eMIOS pins at reset</p>
ETRIG[2:3]	SIU – eQADC Triggers	External signal eTRIGx triggers eQADC CFIFOx
GPIO[206] ETRIG0 (Input)	SIU – eQADC Triggers	External signal eTRIGx triggers eQADC CFIFOx
GPIO[207] ETRIG1 (Input)	SIU – eQADC Triggers	External signal eTRIGx triggers eQADC CFIFOx
IRQ[0:5] IRQ[7:15]	SIU – External Interrupts	<p>The IRQ[0:15] pins connect to the SIU IRQ inputs. IMUX Select Register 1 is used to select the IRQ[0:15] pins as inputs to the IRQs.</p> <p>See reference manual section “External IRQ Input Select Register (SIU_EIISR)” for more information.</p>
NMI	SIU – External Interrupts	Non-Maskable Interrupt

Table 5. Signal details (continued)

Signal	Module or function	Description
GPIO[12:17] GPIO[75:110] GPIO[113:145] GPIO[179:204] GPIO[206:213] GPIO[219] GPIO[244:245]	SIU – GPIO	Configurable general purpose I/O pins. Each GPIO input and output is separately controlled by an 8-bit input (GPDI) or output (GPDO) register. Additionally, each GPIO pin is configured using a dedicated SIU_PCR register. The GPIO pins are generally multiplexed with other I/O pin functions. See the following reference manual sections for more information: <ul style="list-style-type: none"> • “Pad Configuration Registers (SIU_PCR)” • “GPIO Pin Data Output Registers (SIU_GPDO0_3 – SIU_GPDO412_413)” • “GPIO Pin Data Input Registers (SIU_GPDI0_3 – SIU_GPDI_232)”
RESET	SIU – Reset	The $\overline{\text{RESET}}$ pin is an active low input. The $\overline{\text{RESET}}$ pin is asserted by an external device during a power-on or external reset. The internal reset signal asserts only if the $\overline{\text{RESET}}$ pin asserts for 10 clock cycles. Assertion of the $\overline{\text{RESET}}$ pin while the device is in reset causes the reset cycle to start over. The $\overline{\text{RESET}}$ pin has a glitch detector which detects spikes greater than two clock cycles in duration that fall below the switch point of the input buffer logic of the VDDEH input pins. The switch point lies between the maximum VIL and minimum VIH specifications for the VDDEH input pins.
RSTCFG	SIU – Reset	Used to enable or disable the PLLREF and the BOOTCFG[0:1] configuration signals. 0: Get configuration information from BOOTCFG[0:1] and PLLREF 1: Use default configuration of booting from internal flash with crystal clock source Note: For the 176-pin QFP and 208-ball BGA packages RSTCFG is always 0, so PLLREF and BOOTCFG signals are used.
$\overline{\text{RSTOUT}}$	SIU – Reset	The $\overline{\text{RSTOUT}}$ pin is an active low output that uses a push/pull configuration. The $\overline{\text{RSTOUT}}$ pin is driven to the low state by the MCU for all internal and external reset sources. There is a delay between initiation of the reset and the assertion of the $\overline{\text{RSTOUT}}$ pin. See reference manual section “RSTOUT” for details.

Table 6. Power/ground segmentation

Power segment	Voltage	I/O pins powered by segment
VDDE5	3.0 V – 3.6 V	DATA[0:15], CLKOUT, ENGCLK
VDDE12	3.0 V – 3.6 V	CAL_CS0, CAL_CS2, CAL_CS3, CAL_ADDR[12:30], CAL_DATA[0:15], CAL_RD_WR, CAL_WE0, CAL_WE1, CAL_OE, CAL_TS
VDDE-EH	3.0 V – 5.5 V	FR_A_TX, FR_A_TX_EN, FR_A_RX, FR_B_TX, FR_B_TX_EN, FR_B_RX
VDDEH1	3.3 V – 5.5 V	ETPUA[10:31]
VDDEH4	3.3 V – 5.5 V	EMIOS[0:23], TCRCLKA, ETPUA[0:9]
VDDEH6	3.3 V – 5.5 V	RESET, RSTOUT, PLLREF, PLLCFG1, RSTCFG, BOOTCFG0, BOOTCFG1, WKPCFG, CAN_A_TX, CAN_A_RX, CAN_B_TX, CAN_B_RX, CAN_C_TX, CAN_C_RX, SCI_A_TX, SCI_A_RX, SCI_B_TX, SCI_B_RX, SCI_C_TX, SCI_C_RX, DSPI_B_SCK, DSPI_B_SIN, DSPI_B_SOUT, DSPI_B_PCS[0:5], EXTAL, XTAL
VDDEH7	3.3 V – 5.5 V	EMIOS14, EMIOS15, GPIO[98:99], GPIO[203:204], GPIO[206], GPIO[207], GPIO[219], EVTI, EVTO, MDO[4:11], MSEO0, MSEO1, RDY, TCK, TDI, TDO, TMS, JCOMP, DSPI_A_SCK, DSPI_A_SIN, DSPI_A_SOUT, DSPI_A_PCS[0:1], DSPI_A_PCS[4:5], AN12-SDS, AN13-SDO, AN14-SDI, AN15-FCK
VDDA	5.0 V	AN[0:11], AN[16:39], VRH, VRL, REFBYBC
VRC33	3.3 V	MCKO, MDO[0:3]
Other power segments		
VDDREG	5.0 V	—
VRCCTL	—	—
VDDPLL	1.2 V	—
VSTBY	0.9 V – 6.0 V	—
VSS	—	—

3 Electrical characteristics

This section contains detailed information on power considerations, DC/AC electrical characteristics, and AC timing specifications for the MPC5642A series of MCUs.

The electrical specifications are preliminary and are from previous designs, design simulations, or initial evaluation. These specifications may not be fully tested or guaranteed at this early stage of the product life cycle, however for production silicon these specifications will be met. Finalized specifications will be published after complete characterization and device qualifications have been completed.

In the tables where the device logic provides signals with their respective timing characteristics, the symbol “CC” for Controller Characteristics is included in the Symbol column.

In the tables where the external system must provide signals with their respective timing characteristics to the device, the symbol “SR” for System Requirement is included in the Symbol column.

3.1 Parameter classification

The electrical parameters shown in this supplement are guaranteed by various methods. To give the customer a better understanding, the classifications listed in [Table 7](#) are used and the parameters are tagged accordingly in the tables where appropriate.

Table 7. Parameter classifications

Classification tag	Tag description
P	Those parameters are guaranteed during production testing on each individual device.
C	Those parameters are achieved by the design characterization by measuring a statistically relevant sample size across process variations.
T	Those parameters are achieved by design characterization on a small sample size from typical devices under typical conditions unless otherwise noted. All values shown in the typical column are within this category.
D	Those parameters are derived mainly from simulations.

NOTE

The classification is shown in the column labeled “C” in the parameter tables where appropriate.

3.2 Maximum ratings

Table 8. Absolute maximum ratings¹

Symbol		Parameter	Conditions	Value		Unit
				Min	Max	
V_{DD}	SR	1.2 V core supply voltage ²		-0.3	1.32	V
V_{FLASH}	SR	Flash core voltage ^{3,4}		-0.3	3.6	V
V_{STBY}	SR	SRAM standby voltage ⁵		-0.3	6.0	V
V_{DDPLL}	SR	Clock synthesizer voltage ³		-0.3	1.32	V
V_{RC33}	SR	Voltage regulator control input voltage ⁴		-0.3	3.6	V
V_{DDA}	SR	Analog supply voltage ⁵	Reference to V_{SSA}	-0.3	5.5	V
V_{DDE}	SR	I/O supply voltage ^{4,6}		-0.3	3.6	V
V_{DDEH}	SR	I/O supply voltage ^{5,7}		-0.3	5.5	V
V_{IN}	SR	DC input voltage ⁸	V_{DDEH} powered I/O pads	-1.0 ¹⁰	$V_{DDEH} + 0.3 V^9$	V
			V_{DDE} powered I/O pads	-1.0 ¹⁴	$V_{DDE} + 0.3 V^{10}$	
			V_{DDA} powered I/O pads	-1.0	5.5	
V_{DDREG}	SR	Voltage regulator supply voltage		-0.3	5.5	V
V_{RH}	SR	Analog reference high voltage	Reference to V_{RL}	-0.3	5.5	V
$V_{SS} - V_{SSA}$	SR	V_{SS} differential voltage		-0.1	0.1	V
$V_{RH} - V_{RL}$	SR	V_{REF} differential voltage		-0.3	5.5	V
$V_{RL} - V_{SSA}$	SR	V_{RL} to V_{SSA} differential voltage		-0.3	0.3	V
$V_{SSPLL} - V_{SS}$	SR	V_{SSPLL} to V_{SS} differential voltage		-0.1	0.1	V
I_{MAXD}	SR	Maximum DC digital input current ¹¹	Per pin, applies to all digital pins	-3	3	mA
I_{MAXA}	SR	Maximum DC analog input current ¹²	Per pin, applies to all analog pins	—	5 ¹³	mA
T_J	SR	Maximum operating temperature range — die junction temperature		-40.0	150.0	°C
T_{STG}	SR	Storage temperature range		-55	150	°C
T_{SDR}	SR	Maximum solder temperature ¹⁴		—	260	°C
MSL	SR	Moisture sensitivity level ¹⁵		—	3	—

¹ Functional operating conditions are given in the DC electrical specifications. Absolute maximum ratings are stress ratings only, and functional operation at the maxima is not guaranteed. Stress beyond the listed maxima may affect device reliability or cause permanent damage to the device.

² Allowed 2 V for 10 hours cumulative time, remaining time at 1.2 V + 10%

³ The V_{FLASH} supply is connected to V_{RC33} in the package substrate. This specification applies to calibration package devices only.

⁴ Allowed 5.3 V for 10 hours cumulative time, remaining time at 3.3 V + 10%

⁵ Allowed 5.9 V for 10 hours cumulative time, remaining time at 5 V + 10%

- ⁶ All functional non-supply I/O pins are clamped to V_{SS} and V_{DDE} , or V_{DDEH} .
- ⁷ Internal structures hold the voltage greater than -1.0 V if the injection current limit of 2 mA is met.
- ⁸ AC signal overshoot and undershoot of up to 2.0 V of the input voltages is permitted for an accumulative duration of 60 hours over the complete lifetime of the device (injection current not limited for this duration).
- ⁹ Internal structures hold the input voltage less than the maximum voltage on all pads powered by V_{DDEH} supplies, if the maximum injection current specification is met (2 mA for all pins) and V_{DDEH} is within the operating voltage specifications.
- ¹⁰ Internal structures hold the input voltage less than the maximum voltage on all pads powered by V_{DDE} supplies, if the maximum injection current specification is met (2 mA for all pins) and V_{DDE} is within the operating voltage specifications.
- ¹¹ Total injection current for all pins (including both digital and analog) must not exceed 25 mA.
- ¹² Total injection current for all analog input pins must not exceed 15 mA.
- ¹³ Lifetime operation at these specification limits is not guaranteed.
- ¹⁴ Solder profile per IPC/JEDEC J-STD-020D
- ¹⁵ Moisture sensitivity per JEDEC test method A112

3.3 Thermal characteristics

Table 9. Thermal characteristics for 176-pin LQFP¹

Symbol	C	D	Parameter	Conditions	Value	Unit
R _{θJA}	CC	D	Junction-to-ambient, natural convection ²	Single-layer board – 1s	38	°C/W
R _{θJA}	CC	D	Junction-to-ambient, natural convection ²	Four-layer board – 2s2p	31	°C/W
R _{θJMA}	CC	D	Junction-to-moving-air, ambient ²	at 200 ft./min., single-layer board – 1s	30	°C/W
	CC	D		at 200 ft./min., four-layer board – 2s2p	25	°C/W
R _{θJB}	CC	D	Junction-to-board ³		20	°C/W
R _{θJCTop}	CC	D	Junction-to-case ⁴		5	°C/W
Ψ _{JT}	CC	D	Junction-to-package top, natural convection ⁵		2	°C/W

¹ Thermal characteristics are targets based on simulation that are subject to change per device characterization.

² Junction-to-Ambient Thermal Resistance determined per JEDEC JESD51-3 and JESD51-6. Thermal test board meets JEDEC specification for this package.

³ Junction-to-Board thermal resistance determined per JEDEC JESD51-8. Thermal test board meets JEDEC specification for the specified package.

⁴ Junction-to-Case at the top of the package determined using MIL-STD 883 Method 1012.1. The cold plate temperature is used for the case temperature. Reported value includes the thermal resistance of the interface layer.

⁵ Thermal characterization parameter indicating the temperature difference between the package top and the junction temperature per JEDEC JESD51-2. When Greek letters are not available, the thermal characterization parameter is written as Psi-JT.

Table 10. Thermal characteristics for 208-pin MAPBGA¹

Symbol	C	D	Parameter	Conditions	Value	Unit
R _{θJA}	CC	D	Junction-to-ambient, natural convection ²	Single layer board – 1s ³	39	°C/W
	CC	D		Four layer board – 2s2p ⁴	24	°C/W
R _{θJMA}	CC	D	Junction-to-moving-air, ambient ²	at 200 ft./min., single-layer board – 1s ⁴	31	°C/W
	CC	D		at 200 ft./min., four-layer board – 2s2p	20	°C/W
R _{θJB}	CC	D	Junction-to-board ⁵	Four-layer board – 2s2p	13	°C/W
R _{θJC}	CC	D	Junction-to-case ⁶		6	°C/W
Ψ _{JT}	CC	D	Junction-to-package top natural convection ⁷		2	°C/W

¹ Thermal characteristics are targets based on simulation that are subject to change per device characterization.

² Junction temperature is a function of die size, on-chip power dissipation, package thermal resistance, mounting site (board) temperature, ambient temperature, air flow, power dissipation of other components on the board, and board thermal resistance.

³ Per SEMI G38-87 and JEDEC JESD51-2 with the single-layer board horizontal

⁴ Per JEDEC JESD51-6 with the board horizontal

⁵ Thermal resistance between the die and the printed circuit board per JEDEC JESD51-8. Board temperature is measured on the top surface of the board near the package.

⁶ Indicates the average thermal resistance between the die and the case top surface as measured by the cold plate method (MIL SPEC-883 Method 1012.1) with the cold plate temperature used for the case temperature.

- ⁷ Thermal characterization parameter indicating the temperature difference between package top and the junction temperature per JEDEC JESD51-2. When Greek letters are not available, the thermal characterization parameter is written as Psi-JT.

Table 11. Thermal characteristics for 324-pin TEPBGA¹

Symbol	C	D	Parameter	Conditions	Value	Unit
R _{θJA}	CC	D	Junction-to-ambient, natural convection ²	Single-layer board – 1s	29	°C/W
	CC	D		Four-layer board – 2s2p	19	°C/W
R _{θJMA}	CC	D	Junction-to-moving-air, ambient ²	at 200 ft./min., single-layer board – 1s	23	°C/W
	CC	D		at 200 ft./min., four-layer board – 2s2p	16	°C/W
R _{θJB}	CC	D	Junction-to-board ³		10	°C/W
R _{θJctop}	CC	D	Junction-to-case ⁴		7	°C/W
Ψ _{JT}	CC	D	Junction-to-package top, natural convection ⁵		2	°C/W

¹ Thermal characteristics are targets based on simulation that are subject to change per device characterization.

² Junction-to-Ambient Thermal Resistance determined per JEDEC JESD51-3 and JESD51-6. Thermal test board meets JEDEC specification for this package.

³ Junction-to-Board thermal resistance determined per JEDEC JESD51-8. Thermal test board meets JEDEC specification for the specified package.

⁴ Junction-to-Case at the top of the package determined using MIL-STD 883 Method 1012.1. The cold plate temperature is used for the case temperature. Reported value includes the thermal resistance of the interface layer.

⁵ Thermal characterization parameter indicating the temperature difference between the package top and the junction temperature per JEDEC JESD51-2. When Greek letters are not available, the thermal characterization parameter is written as Psi-JT.

3.3.1 General notes for specifications at maximum junction temperature

An estimation of the chip junction temperature, T_J, can be obtained from [Equation 1](#):

$$T_J = T_A + (R_{\theta JA} * P_D) \quad \text{Eqn. 1}$$

where:

T_A = ambient temperature for the package (°C)

R_{θJA} = junction-to-ambient thermal resistance (°C/W)

P_D = power dissipation in the package (W)

The thermal resistance values used are based on the JEDEC JESD51 series of standards to provide consistent values for estimations and comparisons. The difference between the values determined for the single-layer (1s) board compared to a four-layer board that has two signal layers, a power and a ground plane (2s2p), demonstrate that the effective thermal resistance is not a constant. The thermal resistance depends on the:

- Construction of the application board (number of planes)
- Effective size of the board which cools the component
- Quality of the thermal and electrical connections to the planes
- Power dissipated by adjacent components

Connect all the ground and power balls to the respective planes with one via per ball. Using fewer vias to connect the package to the planes reduces the thermal performance. Thinner planes also reduce the thermal performance. When the clearance between the vias leave the planes virtually disconnected, the thermal performance is also greatly reduced.

Electrical characteristics

As a general rule, the value obtained on a single-layer board is within the normal range for the tightly packed printed circuit board. The value obtained on a board with the internal planes is usually within the normal range if the application board has:

- One oz. (35 micron nominal thickness) internal planes
- Components that are well separated
- Overall power dissipation on the board is less than 0.02 W/cm²

The thermal performance of any component depends on the power dissipation of the surrounding components. In addition, the ambient temperature varies widely within the application. For many natural convection and especially closed-box applications, the board temperature at the perimeter (edge) of the package is approximately the same as the local air temperature near the device. Specifying the local ambient conditions explicitly as the board temperature provides a more precise description of the local ambient conditions that determine the temperature of the device.

At a known board temperature, the junction temperature is estimated using [Equation 2](#):

$$T_J = T_B + (R_{\theta JB} * P_D) \quad \text{Eqn. 2}$$

where:

T_B = board temperature for the package perimeter (°C)

$R_{\theta JB}$ = junction-to-board thermal resistance (°C/W) per JESD51-8S

P_D = power dissipation in the package (W)

When the heat loss from the package case to the air does not factor into the calculation, an acceptable value for the junction temperature is predictable. Ensure the application board is similar to the thermal test condition, with the component soldered to a board with internal planes.

The thermal resistance is expressed as the sum of a junction-to-case thermal resistance plus a case-to-ambient thermal resistance:

$$R_{\theta JA} = R_{\theta JC} + R_{\theta CA} \quad \text{Eqn. 3}$$

where:

$R_{\theta JA}$ = junction-to-ambient thermal resistance (°C/W)

$R_{\theta JC}$ = junction-to-case thermal resistance (°C/W)

$R_{\theta CA}$ = case to ambient thermal resistance (°C/W)

$R_{\theta JC}$ is device-related and is not affected by other factors. The thermal environment can be controlled to change the case-to-ambient thermal resistance, $R_{\theta CA}$. For example, change the air flow around the device, add a heat sink, change the mounting arrangement on the printed circuit board, or change the thermal dissipation on the printed circuit board surrounding the device. This description is most useful for packages with heat sinks where 90% of the heat flow is through the case to heat sink to ambient. For most packages, a better model is required.

A more accurate two-resistor thermal model can be constructed from the junction-to-board thermal resistance and the junction-to-case thermal resistance. The junction-to-case thermal resistance describes when using a heat sink or where a substantial amount of heat is dissipated from the top of the package. The junction-to-board thermal resistance describes the thermal performance when most of the heat is conducted to the printed circuit board. This model can be used to generate simple estimations and for computational fluid dynamics (CFD) thermal models.

To determine the junction temperature of the device in the application on a prototype board, use the thermal characterization parameter (Ψ_{JT}) to determine the junction temperature by measuring the temperature at the top center of the package case using [Equation 4](#):

$$T_J = T_T + (\Psi_{JT} * P_D) \quad \text{Eqn. 4}$$

where:

T_T = thermocouple temperature on top of the package (°C)

Ψ_{JT} = thermal characterization parameter ($^{\circ}\text{C}/\text{W}$)

P_D = power dissipation in the package (W)

The thermal characterization parameter is measured in compliance with the JESD51-2 specification using a 40-gauge type T thermocouple epoxied to the top center of the package case. Position the thermocouple so that the thermocouple junction rests on the package. Place a small amount of epoxy on the thermocouple junction and approximately 1 mm of wire extending from the junction. Place the thermocouple wire flat against the package case to avoid measurement errors caused by the cooling effects of the thermocouple wire.

References:

- Semiconductor Equipment and Materials International
3081 Zanker Road
San Jose, CA 95134
USA
Phone (+1) 408-943-6900
- MIL-SPEC and EIA/JESD (JEDEC) specifications available from Global Engineering Documents (phone (+1) 800-854-7179 or (+1) 303-397-7956)
- JEDEC specifications available on the Web at <http://www.jedec.org>
- C.E. Triplett and B. Joiner, “*An Experimental Characterization of a 272 PBGA Within an Automotive Engine Controller Module*,” Proceedings of SemiTherm, San Diego, 1998, pp. 47-54.
- G. Kromann, S. Shidore, and S. Addison, “*Thermal Modeling of a PBGA for Air-Cooled Applications*”, Electronic Packaging and Production, pp. 53-58, March 1998.
- B. Joiner and V. Adams, “*Measurement and Simulation of Junction to Board Thermal Resistance and Its Application in Thermal Modeling*,” Proceedings of SemiTherm, San Diego, 1999, pp. 212-220.

3.4 EMI (electromagnetic interference) characteristics

Table 12. EMI testing specifications¹

Symbol	Parameter	Conditions	$f_{\text{osc}}/f_{\text{BUS}}$	Frequency	Level (max)	Unit	
$V_{\text{RE_TEM}}$	Radiated emissions, electric field	$V_{\text{DD}} = 5.25 \text{ V};$ $T_A = +25 \text{ }^{\circ}\text{C}$ 150 kHz–30 MHz — RBW 9 kHz, step size 5 kHz 30 MHz–1 GHz — RBW 120 kHz, step size 80 kHz	16 MHz crystal 40 MHz bus No PLL frequency modulation	150 kHz–50 MHz	20	dB μ V	
				50–150 MHz	20		
				150–500 MHz	26		
				500–1000 MHz	26		
				IEC Level	K		—
				SAE Level	3		—
			16 MHz crystal 40 MHz bus $\pm 2\%$ PLL frequency modulation	150 kHz–50 MHz	13	dB μ V	
				50–150 MHz	13		
				150–500 MHz	11		
				500–1000 MHz	13		
				IEC Level	L	—	
				SAE Level	2	—	

¹ EMI testing and I/O port waveforms per standard IEC 61967-2.

3.5 Electrostatic discharge (ESD) characteristics

 Table 13. ESD ratings^{1,2}

Symbol		Parameter	Conditions	Value	Unit
—	SR	ESD for Human Body Model (HBM)	—	2000	V
R1	SR	HBM circuit description	—	1500	Ω
C	SR		—	100	pF
—	SR	ESD for Field Induced Charge Model (FDCM)	All pins	500	V
			Corner pins	750	
—	SR	Number of pulses per pin	Positive pulses (HBM)	1	—
			Negative pulses (HBM)	1	—
—	SR	Number of pulses	—	1	—

¹ All ESD testing is in conformity with CDF-AEC-Q100 Stress Test Qualification for Automotive Grade Integrated Circuits.

² Device failure is defined as: “If after exposure to ESD pulses, the device does not meet the device specification requirements, which includes the complete DC parametric and functional testing at room temperature and hot temperature.”

3.6 Power management control (PMC) and power on reset (POR) electrical specifications

Table 14. PMC operating conditions and external regulators supply voltage

ID	Name	C	Parameter	Value			Unit	
				Min	Typ	Max		
1	T _J	SR	—	Junction temperature	−40	27	150	°C
2	V _{DDREG}	SR	—	PMC 5 V supply voltage VDDREG	4.75	5	5.25	V
3	V _{DD}	CC	C	Core supply voltage 1.2 V VDD when external regulator is used without disabling the internal regulator (PMC unit turned on, LVI monitor active) ¹	1.26 ²	1.3	1.32	V
3a	—	CC	C	Core supply voltage 1.2 V VDD when external regulator is used with a disabled internal regulator (PMC unit turned-off, LVI monitor disabled)	1.14	1.2	1.32	V
4	I _{VDD}	CC	C	Voltage regulator core supply maximum required DC output current	400	—	—	mA
5	V _{DD33}	CC	C	Regulated 3.3 V supply voltage when external regulator is used without disabling the internal regulator (PMC unit turned-on, internal 3.3V regulator enabled, LVI monitor active) ³	3.3	3.45	3.6	V
5a	—	CC	C	Regulated 3.3 V supply voltage when external regulator is used with a disabled internal regulator (PMC unit turned-off, LVI monitor disabled)	3	3.3	3.6	V
6	—	CC	C	Voltage regulator 3.3 V supply maximum required DC output current	80	—	—	mA

¹ An internal regulator controller can be used to regulate the core supply.

² The minimum supply required for the part to exit reset and enter in normal run mode is 1.28 V.

³ An internal regulator can be used to regulate the 3.3 V supply.

Table 15. PMC electrical characteristics

ID	Name	C	Parameter	Value			Unit
				Min	Typ	Max	
1	V _{BG}	CC	C	Nominal bandgap voltage reference			V
1a	—	CC	C	V _{BG} - 7%	V _{BG}	V _{BG} + 6%	V
1b	—	CC	C	Trimmed bandgap reference voltage (5 V, 27 °C)			V
1c	—	CC	C	V _{BG} - 10mV	V _{BG}	V _{BG} + 10mV	V
1d	—	CC	C	Bandgap reference temperature variation			ppm/°C
1d	—	CC	C	Bandgap reference supply voltage variation			ppm/V
2	V _{DD}	CC	C	Nominal V _{DD} core supply internal regulator target DC output voltage ¹			V
2a	—	CC	C	V _{DD} - 6%	V _{DD}	V _{DD} + 10%	V
2b	—	CC	C	Nominal V _{DD} core supply internal regulator target DC output voltage variation at power-on reset			V
2b	—	CC	C	V _{DD} - 10% ²	V _{DD}	V _{DD} + 3%	V
2c	—	CC	C	Trimming step V _{DD}			mV
2d	I _{VRCCTL}	CC	C	Voltage regulator controller for core supply maximum DC output current			mA
3	Lvi1p2	CC	C	Nominal LVI for rising core supply ³			V
3a	—	CC	C	Variation of LVI for rising core supply at power-on reset ⁴			V
3b	—	CC	C	Variation of LVI for rising core supply after power-on reset ⁴			V
3c	—	CC	C	Lvi1p2 - 3%	Lvi1p2	Lvi1p2 + 3%	V
3c	—	CC	C	Trimming step LVI core supply			mV
3d	Lvi1p2_h	CC	C	LVI core supply hysteresis			mV
4	Por1.2V_r	CC	C	POR 1.2 V rising			V
4a	—	CC	C	POR 1.2 V rising variation			V
4a	—	CC	C	Por1.2V_r - 35%	Por1.2V_r	Por1.2V_r + 35%	V
4b	Por1.2V_f	CC	C	POR 1.2 V falling			V
4c	—	CC	C	POR 1.2 V falling variation			V
4c	—	CC	C	Por1.2V_f - 35%	Por1.2V_f	Por1.2V_f + 35%	V
5	V _{DD33}	CC	C	Nominal 3.3 V supply internal regulator DC output voltage			V
5a	—	CC	C	Nominal 3.3 V supply internal regulator DC output voltage variation at power-on reset			V
5a	—	CC	C	V _{DD33} - 8.5%	V _{DD33}	V _{DD33} + 7%	V
5b	—	CC	C	Nominal 3.3 V supply internal regulator DC output voltage variation after power-on reset ⁵			V
5b	—	CC	C	V _{DD33} - 7.5%	V _{DD33}	V _{DD33} + 7%	V
5c	—	CC	C	Voltage regulator 3.3 V output impedance at maximum DC load			Ω

Table 15. PMC electrical characteristics (continued)

ID	Name	C	Parameter	Value			Unit
				Min	Typ	Max	
5d	Idd3p3	CC	C Voltage regulator 3.3 V maximum DC output current	80	—	—	mA
5e	Vdd33 ILim	CC	C Voltage regulator 3.3 V DC current limit	—	130	—	mA
6	Lvi3p3	CC	C Nominal LVI for rising 3.3 V supply ⁶	—	3.090	—	V
6a	—	CC	C Variation of LVI for rising 3.3 V supply at power-on reset ⁷	Lvi3p3 – 6%	Lvi3p3	Lvi3p3 + 6%	V
6b	—	CC	C Variation of LVI for rising 3.3 V supply after power-on reset ⁷	Lvi3p3 – 3%	Lvi3p3	Lvi3p3 + 3%	V
6c	—	CC	C Trimming step LVI 3.3 V	—	20	—	mV
6d	Lvi3p3_h	CC	C LVI 3.3 V hysteresis	—	60	—	mV
7	Por3.3V_r	CC	C Nominal POR for rising 3.3 V supply ⁸	—	2.07	—	V
7a	—	CC	C Variation of POR for rising 3.3 V supply	Por3.3V_r – 35%	Por3.3V_r	Por3.3V_r + 35%	V
7b	Por3.3V_f	CC	C Nominal POR for falling 3.3 V supply	—	1.95	—	V
7c	—	CC	C Variation of POR for falling 3.3 V supply	Por3.3V_f – 35%	Por3.3V_f	Por3.3V_f + 35%	V
8	Lvi5p0	CC	C Nominal LVI for rising 5 V VDDREG supply	—	4.290	—	V
8a	—	CC	C Variation of LVI for rising 5 V VDDREG supply at power-on reset	Lvi5p0 – 6%	Lvi5p0	Lvi5p0 + 6%	V
8b	—	CC	C Variation of LVI for rising 5 V VDDREG supply power-on reset	Lvi5p0 – 3%	Lvi5p0	Lvi5p0 + 3%	V
8c	—	CC	C Trimming step LVI 5 V	—	20	—	mV
8d	Lvi5p0_h	CC	C LVI 5 V hysteresis	—	60	—	mV
9	Por5V_r	CC	C Nominal POR for rising 5 V VDDREG supply	—	2.67	—	V
9a	—	CC	C Variation of POR for rising 5 V VDDREG supply	Por5V_r – 35%	Por5V_r	Por5V_r + 35%	V
9b	Por5V_f	CC	C Nominal POR for falling 5 V VDDREG supply	—	2.47	—	V
9c	—	CC	C Variation of POR for falling 5 V VDDREG supply	Por5V_f – 35%	Por5V_f	Por5V_f + 35%	V

¹ Using external ballast transistor.

² Min range is extended to 10% since Lvi1p2 is reprogrammed from 1.2 V to 1.16 V after power-on reset.

³ LVI for falling supply is calculated as LVI rising – LVI hysteresis.

⁴ Lvi1p2 tracks DC target variation of internal V_{DD} regulator. Minimum and maximum Lvi1p2 correspond to minimum and maximum V_{DD} DC target respectively.

⁵ With internal load up to Idd3p3

⁶ The Lvi3p3 specs are also valid for the V_{DDEH} LVI

⁷ Lvi3p3 tracks DC target variation of internal V_{DD33} regulator. Minimum and maximum Lvi3p3 correspond to minimum and maximum V_{DD33} DC target respectively.

⁸ The 3.3V POR specs are also valid for the V_{DDEH} POR

3.6.1 Regulator example

In designs where the MPC5642A microcontroller's internal regulators are used, a ballast is required for generation of the 1.2 V internal supply. No ballast is required when an external 1.2 V supply is used.

The resistor may or may not be required. This depends on the allowable power dissipation of the npn bypass transistor device. The resistor may be used to limit the in-rush current at power on.

The bypass transistor **MUST** be operated out of saturation region.

Mandatory decoupling capacitor network

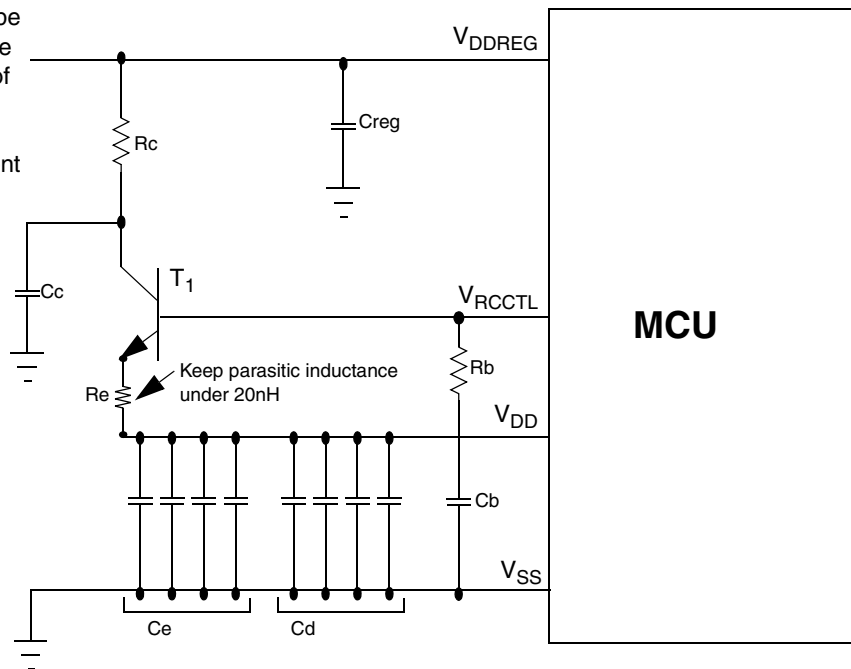

VRCCTL capacitor and resistor is required

Figure 8. Core voltage regulator controller external components preferred configuration

Table 16. MPC5642A External network specification

External Network Parameter	Min	Typ	Max	Comment
T1	—	—	—	NJD2873 or BCP68 only
Cb	1.1 μF	2.2 μF	2.97 μF	X7R, -50%/+35%
Ce	3*2.35 μF +5 μF	3*4.7 μF +10 μF	3*6.35 μF +13.5 μF	X7R, -50%/+35%
Equivalent ESR of Ce capacitors	5m Ω	—	50m Ω	—
Cd	4*50nF	4*100nF	4*135nF	X7R, -50%/+35%
Rb	9 Ω	10 Ω	11 Ω	+/-10%

Table 16. MPC5642A External network specification (continued)

External Network Parameter	Min	Typ	Max	Comment
Re	0.252 Ω	0.280 Ω	0.308 Ω	+/-10%
Creg	—	10 μ F	—	It depends on external Vreg.
Cc	5 μ F	10 μ F	13.5 μ F	X7R, -50%/+35%
Rc	1.1 Ω	—	5.6 Ω	May or may not be required. It depends on the allowable power dissipation of T1.

3.6.2 Recommended power transistors

The following NPN transistors are recommended for use with the on-chip voltage regulator controller: ON Semiconductor™ BCP68T1 or NJD2873 as well as Philips Semiconductor™ BCP68. The collector of the external transistor is preferably connected to the same voltage supply source as the output stage of the regulator.

Table 17. Transistor recommended operating characteristics

Symbol	Parameter	Value	Unit
h_{FE} (β)	DC current gain (Beta)	60–550	—
P_D	Absolute minimum power dissipation	>1.0 (1.5 preferred)	W
I_{CMaxDC}	Minimum peak collector current	1.0	A
$V_{CE_{SAT}}$	Collector-to-emitter saturation voltage	200–600 ¹	mV
V_{BE}	Base-to-emitter voltage	0.4–1.0	V

¹ Adjust resistor at bipolar transistor collector for 3.3 V/5.0 V to avoid $V_{CE} < V_{CE_{SAT}}$

3.7 Power up/down sequencing

There is no power sequencing required among power sources during power up and power down, in order to operate within specification.

Although there are no power up/down sequencing requirements to prevent issues such as latch-up or excessive current spikes, the state of the I/O pins during power up/down varies according to [Table 18](#) for all pins with pad type fast, and [Table 19](#) for all pins with pad type medium, slow, and multi-voltage.

Table 18. Power sequence pin states—Fast type pads

V_{DDE}	V_{RC33}	V_{DD}	Pin state
Low	X	X	Low
V_{DDE}	Low	X	High
V_{DDE}	V_{RC33}	Low	High impedance
V_{DDE}	V_{RC33}	V_{DD}	Functional

Table 19. Power sequence pin states—Medium, slow and multi-voltage type pads

V_{DDEH}	V_{DD}	Pin state
LOW	X	Low
V_{DDEH}	Low	High impedance
V_{DDEH}	V_{DD}	Functional

3.8 DC electrical specifications

Table 20. DC electrical specifications¹

Symbol		C	Parameter	Conditions	Value			Unit
					Min	Typ	Max	
V_{DD}	SR	P	Core supply voltage	—	1.14	—	1.32	V
V_{DDE}	SR	P	I/O supply voltage	—	3.0	—	3.6	V
V_{DDEH}	SR	P	I/O supply voltage	—	3.0	—	5.25	V
V_{DDE-EH}	SR	P	I/O supply voltage	—	3.0	—	5.25	V
V_{RC33}	SR	P	3.3 V regulated voltage ²	—	3.0	—	3.6	V
V_{DDA}	SR	P	Analog supply voltage	—	4.75 ³	—	5.25	V
V_{INDC}	SR	C	Analog input voltage	—	$V_{SSA} - 0.3$	—	$V_{DDA} + 0.3$	V
$V_{SS} - V_{SSA}$	SR	D	V_{SS} differential voltage	—	-100	—	100	mV
V_{RL}	SR	D	Analog reference low voltage	—	V_{SSA}	—	$V_{SSA} + 0.1$	V
$V_{RL} - V_{SSA}$	SR	D	V_{RL} differential voltage	—	-100	—	100	mV
V_{RH}	SR	D	Analog reference high voltage	—	$V_{DDA} - 0.1$	—	V_{DDA}	V
$V_{RH} - V_{RL}$	SR	P	V_{REF} differential voltage	—	4.75	—	5.25	V
V_{DDF}	SR	P	Flash operating voltage ⁴	—	1.14	—	1.32	V
V_{FLASH} ⁵	SR	P	Flash read voltage	—	3.0	—	3.6	V
V_{STBY}	SR	C	SRAM standby voltage	Unregulated mode	0.95	—	1.2	V
				Regulated mode	2.0	—	5.5	
V_{DDREG}	SR	P	Voltage regulator supply voltage ⁶	—	4.75	—	5.25	V
V_{DDPLL}	SR	P	Clock synthesizer operating voltage	—	1.14	—	1.32	V
$V_{SSPLL} - V_{SS}$	SR	D	V_{SSPLL} to V_{SS} differential voltage	—	-100	—	100	mV
V_{IL_S}	SR	P	Slow/medium I/O input low voltage	Hysteresis enabled	$V_{SS} - 0.3$	—	$0.35 * V_{DDEH}$	V
				Hysteresis disabled	$V_{SS} - 0.3$	—	$0.40 * V_{DDEH}$	
V_{IL_F}	SR	P	Fast I/O input low voltage	Hysteresis enabled	$V_{SS} - 0.3$	—	$0.35 * V_{DDE}$	V
				Hysteresis disabled	$V_{SS} - 0.3$	—	$0.40 * V_{DDE}$	

Table 20. DC electrical specifications¹ (continued)

Symbol	C	Parameter	Conditions	Value			Unit	
				Min	Typ	Max		
V _{IL_LS}	SR	P	Multi-voltage I/O pad input low voltage in Low-swing-mode ^{7,8,9,10}	Hysteresis enabled	V _{SS} - 0.3	—	0.8	V
		P		Hysteresis disabled	V _{SS} - 0.3	—	0.9	
V _{IL_HS}	SR	P	Multi-voltage pad I/O input low voltage in high-swing-mode	Hysteresis enabled	V _{SS} - 0.3	—	0.35 V _{DDEH}	V
		P		Hysteresis disabled	V _{SS} - 0.3	—	0.4 V _{DDEH}	
V _{IH_S}	SR	P	Slow/medium pad I/O input high voltage	Hysteresis enabled	0.65 V _{DDEH}	—	V _{DDEH} + 0.3	V
		P		Hysteresis disabled	0.55 V _{DDEH}	—	V _{DDEH} + 0.3	
V _{IH_F}	SR	P	Fast I/O input high voltage	Hysteresis enabled	0.65 V _{DDE}	—	V _{DDE} + 0.3	V
		P		Hysteresis disabled	0.58 V _{DDE}	—	V _{DDE} + 0.3	
V _{IH_LS}	SR	P	Multi-voltage pad I/O input high voltage in low-swing-mode ^{7,8,9,10}	Hysteresis enabled	2.5	—	V _{DDE} + 0.3	V
		P		Hysteresis disabled	2.2	—	V _{DDE} + 0.3	
V _{IH_HS}	SR	P	Multi-voltage I/O input high voltage in high-swing-mode	Hysteresis enabled	0.65 V _{DDEH}	—	V _{DDEH} + 0.3	V
		P		Hysteresis disabled	0.55 V _{DDEH}	—	V _{DDEH} + 0.3	
V _{OL_S}	CC	P	Slow/medium pad I/O output low voltage ¹¹	—	—	—	0.2 * V _{DDEH}	V
V _{OL_F}	CC	P	Fast I/O output low voltage ¹¹	—	—	—	0.2 * V _{DDE}	V
V _{OL_LS}	CC	P	Multi-voltage pad I/O output low voltage in low-swing mode ^{7,8,9,10,11}	—	—	—	0.6	V
V _{OL_HS}	CC	P	Multi-voltage pad I/O output low voltage in high-swing mode ¹¹	—	—	—	0.2 V _{DDEH}	V
V _{OH_S}	CC	P	Slow/medium I/O output high voltage ¹¹	—	0.8 V _{DDEH}	—	—	V
V _{OH_F}	CC	P	Fast pad I/O output high voltage ¹¹	—	0.8 V _{DDE}	—	—	V
V _{OH_LS}	CC	P	Multi-voltage pad I/O output high voltage in low-swing mode ^{7,8,9,10,11}	—	2.3	3.1	3.7	V
V _{OH_HS}	CC	P	Multi-voltage pad I/O output high voltage in high-swing mode ¹¹	—	0.8 V _{DDEH}	—	—	V
V _{HYS_S}	CC	P	Slow/medium/multi-voltage I/O input hysteresis	—	0.1 * V _{DDEH}	—	—	V
V _{HYS_F}	CC	P	Fast I/O input hysteresis	—	0.1 * V _{DDE}	—	—	V
V _{HYS_LS}	CC	C	Low-swing-mode multi-voltage I/O input hysteresis	Hysteresis enabled	0.25	—	—	v

Table 20. DC electrical specifications¹ (continued)

Symbol	C	Parameter	Conditions	Value			Unit	
				Min	Typ	Max		
I _{DD} +I _{DDPLL}	CC	P	Operating current 1.2 V supplies	V _{DD} @ 1.32 V @ 80 MHz	—	—	300	mA
				V _{DD} @ 1.32 V @ 120 MHz	—	—	360	mA
				V _{DD} @ 1.32 V @ 150 MHz	—	—	400	mA
I _{DDSTBY}	CC	T	Operating current 0.95-1.2 V	V _{STBY} at 55 °C	—	35	100	μA
		T	Operating current 2-5.5 V	V _{STBY} at 55 °C	—	45	110	μA
I _{DDSTBY27}	CC	P	Operating current 0.95-1.2 V	V _{STBY} 27 °C	—	25	90	μA
		P	Operating current 2-5.5 V	V _{STBY} 27 °C	—	35	100	μA
I _{DDSTBY150}	CC	P	Operating current 0.95-1.2 V	V _{STBY} 150 °C	—	790	2000	μA
		P	Operating current 2-5.5 V	V _{STBY} at 150 °C	—	760	2000	μA
I _{DDPLL}	CC	P	Operating current 1.2 V supplies	V _{DDPLL} , 80 MHz, V _{DD} =1.2 V	—	—	15	mA
I _{DDSLow} I _{DDSTOP}	CC	C	V _{DD} low-power mode operating current @ 1.32 V	Slow mode ¹²	—	—	191	mA
		C		Stop mode ¹³	—	—	190	
I _{DD33}	CC	P	Operating current 3.3 V supplies	V _{RC33} ²	—	—	60	mA
I _{DDA} I _{REF} I _{DDREG}	CC	P	Operating current 5.0 V supplies	V _{DDA}	—	—	30.0	mA
		P		Analog reference supply current (transient)	—	—	1.0	
		P		V _{DDREG}	—	—	70 ¹⁴	
I _{DDH1} I _{DDH4} I _{DDH6} I _{DDH7} I _{DD7} I _{DDH9} I _{DD12}	CC	P	Operating current V _{DDE} ¹⁵ supplies	V _{DDEH1}	—	—	See note ¹⁵	mA
		P		V _{DDEH4}	—	—		
		P		V _{DDEH6}	—	—		
		P		V _{DDEH7}	—	—		
		P		V _{DDE7}	—	—		
		P		V _{DDEH9}	—	—		
		P		V _{DDE12}	—	—		

Table 20. DC electrical specifications¹ (continued)

Symbol	C	Parameter	Conditions	Value			Unit	
				Min	Typ	Max		
I _{ACT_S}	CC	P	Slow/medium I/O weak pull-up/down current ¹⁶	3.0 V–3.6 V	15	—	95	μA
				4.75 V–5.25 V	35	—	200	
I _{ACT_F}	CC	P	Fast I/O weak pull-up/down current ¹⁶	1.62 V–1.98 V	36	—	120	μA
				2.25 V–2.75 V	34	—	139	
				3.0 V–3.6 V	42	—	158	
I _{ACT_MV_PU}	CC	C	Multi-voltage pad weak pull-up current	V _{DDE} = 3.0 – 3.6 V ⁷ , multi-voltage, high swing mode only	10	—	75	μA
				4.75 V–5.25 V	25	—	175	
I _{ACT_MV_PD}	CC	C	Multi-voltage pad weak pull-down current	V _{DDE} = 3.0 – 3.6 V ⁷ , multi-voltage, all process corners, high swing mode only	10	—	60	μA
				4.75 V–5.25 V	25	—	200	
I _{INACT_D}	CC	P	I/O input leakage current ¹⁷	—	–2.5	—	2.5	μA
I _{IC}	SR	T	DC injection current (per pin)	—	–1.0	—	1.0	mA
I _{INACT_A}	SR	P	Analog input current, channel off, AN[0:7] ¹⁸	—	–250	—	250	nA
		P	Analog input current, channel off, all other analog pins ¹⁸	—	–150	—	150	
C _L	CC	D	Load capacitance (fast I/O) ¹⁹	DSC(PCR[8:9]) = 0b00	—	—	10	pF
				DSC(PCR[8:9]) = 0b01	—	—	20	
				DSC(PCR[8:9]) = 0b10	—	—	30	
				DSC(PCR[8:9]) = 0b11	—	—	50	
C _{IN}	CC	D	Input capacitance (digital pins)	—	—	—	7	pF
C _{IN_A}	CC	D	Input capacitance (analog pins)	—	—	—	10	pF
C _{IN_M}	CC	D	Input capacitance (digital and analog pins ²⁰)	—	—	—	12	pF
R _{PUPD200K}	SR	C	Weak pull-up/down resistance ²¹ , 200 kΩ option	—	130	—	280	kΩ

Table 20. DC electrical specifications¹ (continued)

Symbol	C	Parameter	Conditions	Value			Unit	
				Min	Typ	Max		
R _{PUPD100K}	SR	C	Weak pull-up/down resistance ²¹ , 100 kΩ option	—	65	—	140	kΩ
R _{PUPD5K}	SR	C	Weak pull-up/down resistance ²¹ , 5 kΩ option	5 V ± 10% supply	1.4	—	5.2	kΩ
		C		3.3 V ± 10% supply	1.7	—	7.7	
R _{PUPD5K}	SR	C	Weak Pull-Up/Down Resistance ²¹ , 5 kΩ Option	5 V ± 5% supply	1.4	—	7.5	kΩ
R _{PUPDMTCH}	CC	C	Pull-up/Down Resistance matching ratios (100K/200K)	Pull-up and pull-down resistances both enabled and settings are equal.	-2.5	—	2.5	%
T _A (T _L to T _H)	SR	P	Operating temperature range - ambient (packaged)	—	-40.0	—	125.0	°C
—	SR	D	Slew rate on power supply pins	—	—	—	25	V/ms

¹ These specifications are design targets and subject to change per device characterization.

² These specifications apply when V_{RC33} is supplied externally, after disabling the internal regulator (V_{DDREG} = 0).

³ ADC is functional with 4 V ≤ V_{DDA} ≤ 4.75 V but with derated accuracy. This means the ADC will continue to function at full speed with no undesirable behavior, but the accuracy will be degraded.

⁴ The V_{DDF} supply is connected to V_{DD} in the package substrate. This specification applies to calibration package devices only.

⁵ V_{FLASH} is available in the calibration package only.

⁶ Regulator is functional, with derated performance, with supply voltage down to 4.0 V

⁷ Multi-voltage power supply cannot be below 4.5 V when in low-swing mode

⁸ The slew rate (SRC) setting must be 0b11 when in low-swing mode.

⁹ While in low-swing mode there are no restrictions in transitioning to high-swing mode.

¹⁰ Pin in low-swing mode can accept a 5 V input

¹¹ All V_{OL}/V_{OH} values 100% tested with ± 2 mA load except where otherwise noted

¹² Bypass mode, system clock @ 1 MHz (using system clock divider), PLL shut down, CPU running simple executive code, 4 x ADC conversion every 10 ms, 2 x PWM channels @ 1 kHz, all other modules stopped.

¹³ Bypass mode, system clock @ 1 MHz (using system clock divider), CPU stopped, PIT running, all other modules stopped

¹⁴ If 1.2V and 3.3V internal regulators are on, then iddreg=70mA

If supply is external that is 3.3V internal regulator is off, then iddreg=15mA

¹⁵ Power requirements for each I/O segment are dependent on the frequency of operation and load of the I/O pins on a particular I/O segment, and the voltage of the I/O segment. See [Table 21](#) for values to calculate power dissipation for specific operation. The total power consumption of an I/O segment is the sum of the individual power consumptions for each pin on the segment.

¹⁶ Absolute value of current, measured at V_{IL} and V_{IH}

¹⁷ Weak pull-up/down inactive. Measured at V_{DDE} = 3.6 V and V_{DDEH} = 5.25 V. Applies to all digital pad types.

Electrical characteristics

¹⁸ Maximum leakage occurs at maximum operating temperature. Leakage current decreases by approximately one-half for each 8 to 12 °C, in the ambient temperature range of 50 to 125 °C. Applies to analog pads.

¹⁹ Applies to CLKOUT, external bus pins, and Nexus pins

²⁰ Applies to the FCK, SDI, SDO, and SDS pins

²¹ This programmable option applies only to eQADC differential input channels and is used for biasing and sensor diagnostics.

3.9 I/O pad current specifications

The power consumption of an I/O segment depends on the usage of the pins on a particular segment. The power consumption is the sum of all output pin currents for a particular segment. The output pin current can be calculated from [Table 21](#) based on the voltage, frequency, and load on the pin. Use linear scaling to calculate pin currents for voltage, frequency, and load parameters that fall outside the values given in [Table 21](#).

Table 21. I/O pad average I_{DDE} specifications¹

Pad type	Symbol	C	Period (ns)	Load ² (pF)	V_{DDE} (V)	Drive/Slew rate select	I_{DDE} Avg (mA) ³	I_{DDE} RMS (mA)	
Slow	$I_{DRV_SSR_HV}$	CC	D	37	50	5.25	11	9	—
		CC	D	130	50	5.25	01	2.5	—
		CC	D	650	50	5.25	00	0.5	—
		CC	D	840	200	5.25	00	1.5	—
Medium	$I_{DRV_MSR_HV}$	CC	D	24	50	5.25	11	14	—
		CC	D	62	50	5.25	01	5.3	—
		CC	D	317	50	5.25	00	1.1	—
		CC	D	425	200	5.25	00	3	—
Fast	I_{DRV_FC}	CC	D	10	50	3.6	11	22.7	68.3
		CC	D	10	30	3.6	10	12.1	41.1
		CC	D	10	20	3.6	01	8.3	27.7
		CC	D	10	10	3.6	00	4.44	14.3
		CC	D	10	50	1.98	11	12.5	31
		CC	D	10	30	1.98	10	7.3	18.6
		CC	D	10	20	1.98	01	5.42	12.6
		CC	D	10	10	1.98	00	2.84	6.4
MultiV (High swing mode)	$I_{DRV_MULTV_HV}$	CC	D	20	50	5.25	11	9	—
		CC	D	30	50	5.25	01	6.1	—
		CC	D	117	50	5.25	00	2.3	—
		CC	D	212	200	5.25	00	5.8	—
MultiV (Low swing mode)	$I_{DRV_MULTV_HV}$	CC	D	30	30	5.25	11	3.4	—

¹ Numbers from simulations at best case process, 150 °C

² All loads are lumped.

³ Average current is for pad configured as output only

3.9.1 I/O pad V_{RC33} current specifications

The power consumption of the V_{RC33} supply is dependent on the usage of the pins on all I/O segments. The power consumption is the sum of all input and output pin V_{RC33} currents for all I/O segments. The output pin V_{RC33} current can be calculated from [Table 22](#) based on the voltage, frequency, and load on all fast pins. The input pin V_{RC33} current can be calculated from [Table 22](#) based on the voltage, frequency, and load on all medium pins. Use linear scaling to calculate pin currents for voltage, frequency, and load parameters that fall outside the values given in [Table 22](#).

Table 22. I/O pad V_{RC33} average I_{DDE} specifications¹

Pad type	Symbol	C	Period (ns)	Load ² (pF)	Drive select	I_{DD33} Avg (μ A)	I_{DD33} RMS (μ A)	
Slow	$I_{DRV_SSR_HV}$	CC	D	100	50	11	0.8	235.7
		CC	D	200	50	01	0.04	87.4
		CC	D	800	50	00	0.06	47.4
		CC	D	800	200	00	0.009	47
Medium	$I_{DRV_MSR_HV}$	CC	D	40	50	11	2.75	258
		CC	D	100	50	01	0.11	76.5
		CC	D	500	50	00	0.02	56.2
		CC	D	500	200	00	0.01	56.2
MultiV ³ (High swing mode)	$I_{DRV_MULTV_HV}$	CC	D	20	50	11	33.4	35.4
		CC	D	30	50	01	33.4	34.8
		CC	D	117	50	00	33.4	33.8
		CC	D	212	200	00	33.4	33.7
MultiV ⁴ (Low swing mode)	$I_{DRV_MULTV_HV}$	CC	D	30	30	11	33.4	33.7

¹ These are typical values that are estimated from simulation and not tested. Currents apply to output pins only.

² All loads are lumped.

³ Average current is for pad configured as output only

⁴ In low swing mode, multi-voltage pads must operate in highest slew rate setting, $ipp_sre0 = 1$, $ipp_sre1 = 1$.

Table 23. V_{RC33} pad average DC current¹

Pad type	Symbol	C	Period (ns)	Load ² (pF)	V_{RC33} (V)	V_{DDE} (V)	Drive select	I_{DD33} Avg (μ A)	I_{DD33} RMS (μ A)	
Fast	I_{DRV_FC}	CC	D	10	50	3.6	3.6	11	2.35	6.12
		CC	D	10	30	3.6	3.6	10	1.75	4.3
		CC	D	10	20	3.6	3.6	01	1.41	3.43
		CC	D	10	10	3.6	3.6	00	1.06	2.9
		CC	D	10	50	3.6	1.98	11	1.75	4.56
		CC	D	10	30	3.6	1.98	10	1.32	3.44
		CC	D	10	20	3.6	1.98	01	1.14	2.95
		CC	D	10	10	3.6	1.98	00	0.95	2.62

¹ These are typical values that are estimated from simulation and not tested. Currents apply to output pins only.

² All loads are lumped.

3.9.2 LVDS pad specifications

LVDS pads are implemented to support the MSC (Microsecond Channel) protocol which is an enhanced feature of the DSPI module. The LVDS pads are compliant with LVDS specifications and support data rates up to 50 MHz.

Table 24. DSPI LVDS pad specification

Symbol	C	Parameter	Condition	Value			Unit	
				Min	Typ	Max		
Data rate								
$f_{LVDSCLK}$	CC	D	Data frequency	—	50	—	MHz	
Driver specifications								
V_{OD}	CC	P	Differential output voltage	SRC = 0b00 or 0b11	150	—	400	mV
	CC	P		SRC = 0b01	90	—	320	
	CC	P		SRC = 0b10	160	—	480	
V_{OC}	CC	P	Common mode voltage (LVDS), VOS	—	1.06	1.2	1.39	V
T_R/T_F	CC	D	Rise/Fall time	—	—	2	—	ns
T_{PLH}	CC	D	Propagation delay (Low to High)	—	—	4	—	ns
T_{PHL}	CC	D	Propagation delay (High to Low)	—	—	4	—	ns
t_{PDSYNC}	CC	D	Delay (H/L), sync mode	—	—	4	—	ns
T_{DZ}	CC	D	Delay, Z to Normal (High/Low)	—	—	500	—	ns

Table 24. DSPI LVDS pad specification (continued)

Symbol	C	Parameter	Condition	Value			Unit	
				Min	Typ	Max		
T _{SKEW}	CC	D	Differential skew (t _{phla} -t _{plhl} or t _{plhb} -t _{phla})	—	—	0.5	ns	
Termination								
	CC	D	Transmission line (differential Z ₀)	—	95	100	105	W
	CC	D	Temperature	—	-40	—	150	°C

3.10 Oscillator and PLLRFM electrical characteristics

Table 25. PLLRFM electrical specifications¹

 (V_{DDPLL} = 1.08 V to 3.6 V, V_{SS} = V_{SSPLL} = 0 V, T_A = T_L to T_H)

Symbol	C	Parameter	Conditions	Value		Unit	
				Min	Max		
f _{ref_crystal} f _{ref_ext}	CC	P	PLL reference frequency range ²	Crystal reference	4	40	MHz
		P		External reference	4	80	
f _{pll_in}	CC	D	Phase detector input frequency range (after pre-divider)	—	4	16	MHz
f _{vco}	CC	D	VCO frequency range	—	256	512	MHz
f _{sys}	CC	T	On-chip PLL frequency ²	—	16	150	MHz
f _{sys}	CC	T	System frequency in bypass mode ³	Crystal reference	4	40	MHz
		T		External reference	0	80	
t _{cyt}	CC	D	System clock period	—	—	1 / f _{sys}	ns
f _{LORL} f _{LORH}	CC	D	Loss of reference frequency window ⁴	Lower limit	1.6	3.7	MHz
		D		Upper limit	24	56	
f _{scm}	CC	P	Self-clocked mode frequency ^{5,6}	—	1.2	72.25	MHz
C _{JITTER}	CC	C	CLKOUT period jitter ^{7,8,9,10}	f _{sys} maximum	-5	5	% f _{CLKOUT}
		C	Peak-to-peak (clock edge to clock edge)				ns
		C	Long-term jitter (avg. over 2 ms interval)		-6	6	ns
t _{cst}	CC	T	Crystal start-up time ^{11,12}	—	—	10	ms
V _{IHEXT}	CC	D	EXTAL input high voltage	Crystal mode ¹³	V _x tal + 0.4	—	V
		T		External reference ^{13,14}	V _{RC33} /2 + 0.4	V _{RC33}	

Table 25. PLLRFM electrical specifications¹
 ($V_{DDPLL} = 1.08\text{ V to }3.6\text{ V}$, $V_{SS} = V_{SSPLL} = 0\text{ V}$, $T_A = T_L\text{ to }T_H$) (continued)

Symbol	C	Parameter	Conditions	Value		Unit	
				Min	Max		
V_{ILEXT}	CC	D	EXTAL input low voltage	Crystal mode ¹³	—	$V_{xtal} - 0.4$	V
				External reference ^{13,14}	0	$V_{RC33}/2 - 0.4$	
—	CC	T	XTAL load capacitance	—	5	30	pF
—	CC	C	XTAL load capacitance ¹¹	4 MHz	5	30	pF
				8 MHz	5	26	
				12 MHz	5	23	
				16 MHz	5	19	
				20 MHz	5	16	
				40 MHz	5	8	
t_{ppll}	CC	P	PLL lock time ^{11,15}	—	—	200	μs
t_{dc}	CC	D	Duty cycle of reference	—	40	60	%
f_{LCK}	CC	D	Frequency LOCK range	—	-6	6	% f_{sys}
f_{UL}	CC	D	Frequency un-LOCK range	—	-18	18	% f_{sys}
f_{CS} f_{DS}	CC	D	Modulation depth	Center spread	± 0.25	± 4.0	% f_{sys}
				Down spread	-0.5	-8.0	
f_{MOD}	CC	D	Modulation frequency ¹⁶	—	—	100	kHz

¹ All values given are initial design targets and subject to change.

² Considering operation with PLL not bypassed

³ All internal registers retain data at 0 Hz.

⁴ “Loss of Reference Frequency” window is the reference frequency range outside of which the PLL is in self clocked mode.

⁵ Self clocked mode frequency is the frequency that the PLL operates at when the reference frequency falls outside the f_{LOR} window.

⁶ f_{VCO} self clock range is 20–150 MHz. f_{SCM} represents f_{sys} after PLL output divider (ERFD) of 2 through 16 in enhanced mode.

⁷ This value is determined by the crystal manufacturer and board design.

⁸ Jitter is the average deviation from the programmed frequency measured over the specified interval at maximum f_{sys} . Measurements are made with the device powered by filtered supplies and clocked by a stable external clock signal. Noise injected into the PLL circuitry via V_{DDPLL} and V_{SSPLL} and variation in crystal oscillator frequency increase the C_{JITTER} percentage for a given interval.

⁹ Proper PC board layout procedures must be followed to achieve specifications.

¹⁰ Values are with frequency modulation disabled. If frequency modulation is enabled, jitter is the sum of C_{JITTER} and either f_{CS} or f_{DS} (depending on whether center spread or down spread modulation is enabled).

¹¹ This value is determined by the crystal manufacturer and board design. For 4 MHz to 40 MHz crystals specified for this PLL, load capacitors should not exceed these limits.

¹² Proper PC board layout procedures must be followed to achieve specifications.

¹³ This parameter is guaranteed by design rather than 100% tested.

¹⁴ V_{IHEXT} cannot exceed V_{RC33} in external reference mode.

¹⁵ This specification applies to the period required for the PLL to relock after changing the MFD frequency control bits in the synthesizer control register (SYNCR).

¹⁶ Modulation depth will be attenuated from depth setting when operating at modulation frequencies above 50 kHz.

3.11 Temperature sensor electrical characteristics

Table 26. Temperature sensor electrical characteristics

Symbol		C	Parameter	Conditions	Value			Unit
					Min	Typ	Max	
—	CC	C	Temperature monitoring range		-40	—	150	°C
—	CC	C	Sensitivity		—	6.3	—	mV/°C
—	CC	C	Accuracy	$T_J = -40$ to 150 °C	-10	—	10	°C

3.12 eQADC electrical characteristics

Table 27. eQADC conversion specifications (operating)

Symbol		C	Parameter	Value		Unit
				min	max	
f_{ADCLK}	SR	—	ADC clock (ADCLK) frequency	2	16	MHz
CC	CC	D	Conversion cycles	2+13	128+14	ADCLK cycles
T_{SR}	CC	C	Stop mode recovery time ¹	—	10	μs
f_{ADCLK}	SR	—	ADC clock (ADCLK) frequency	2	16	mV

¹ Stop mode recovery time is the time from the setting of either of the enable bits in the ADC Control Register to the time that the ADC is ready to perform conversions. Delay from power up to full accuracy = 8 ms.

Table 28. eQADC single ended conversion specifications (operating)

Symbol		C	Parameter	Value		Unit
				min	max	
OFFNC	CC	C	Offset error without calibration	0	160	Counts
OFFWC	CC	C	Offset error with calibration	-4	4	Counts
GAINNC	CC	C	Full scale gain error without calibration	-160	0	Counts
GAINWC	CC	C	Full scale gain error with calibration	-4	4	Counts
I_{INJ}	CC	T	Disruptive input injection current ^{1, 2, 3, 4}	-3	3	mA
E_{INJ}	CC	T	Incremental error due to injection current ^{5, 6}	-4	4	Counts
TUE8	CC	C	Total unadjusted error (TUE) at 8 MHz	-4	4 ⁶	Counts
TUE16	CC	C	Total unadjusted error at 16 MHz	-8	8	Counts

Electrical characteristics

- ¹ Below disruptive current conditions, the channel being stressed has conversion values of 0x3FF for analog inputs greater than V_{RH} and 0x0 for values less than V_{RL} . Other channels are not affected by non-disruptive conditions.
- ² Exceeding limit may cause conversion error on stressed channels and on unstressed channels. Transitions within the limit do not affect device reliability or cause permanent damage.
- ³ Input must be current limited to the value specified. To determine the value of the required current-limiting resistor, calculate resistance values using $V_{POSCLAMP} = V_{DDA} + 0.5\text{ V}$ and $V_{NEGCLAMP} = -0.3\text{ V}$, then use the larger of the calculated values.
- ⁴ Condition applies to two adjacent pins at injection limits.
- ⁵ Performance expected with production silicon.
- ⁶ All channels have same $10\text{ k}\Omega < R_s < 100\text{ k}\Omega$; Channel under test has $R_s=10\text{ k}\Omega$; $I_{INJ}=I_{INJMAX}, I_{INJMIN}$

Table 29. eQADC differential ended conversion specifications (operating)

Symbol	C	Parameter	Value		Unit		
			min	max			
GAINVGA1 ¹	CC	–	Variable gain amplifier accuracy (gain=1) ²				
	CC	C	INL	8 MHz ADC	–4	4	Counts ₃
	CC	C		16 MHz ADC	–8	8	Counts
	CC	C	DNL	8 MHz ADC	–3 ⁴	3 ⁴	Counts
	CC	C		16 MHz ADC	–3 ⁴	3 ⁴	Counts
GAINVGA2 ¹	CC	–	Variable gain amplifier accuracy (gain=2) ²				
	CC	D	INL	8 MHz ADC	–5	5	Counts
	CC	D		16 MHz ADC	–8	8	Counts
	CC	D	DNL	8 MHz ADC	–3	3	Counts
	CC	D		16 MHz ADC	–3	3	Counts
GAINVGA4 ¹	CC	–	Variable gain amplifier accuracy (gain=4) ²				
	CC	D	INL	8 MHz ADC	–7	7	Counts
	CC	D		16 MHz ADC	–8	8	Counts
	CC	D	DNL	8 MHz ADC	–4	4	Counts
	CC	D		16 MHz ADC	–4	4	Counts

Table 29. eQADC differential ended conversion specifications (operating) (continued)

Symbol		C	Parameter		Value		Unit
					min	max	
$DIFF_{max}$	CC	C	Maximum differential voltage (DANx+ - DANx-) or (DANx- - DANx+) ⁵	PREGAIN set to 1X setting	—	$(VRH - VRL)/2$	V
$DIFF_{max2}$	CC	C		PREGAIN set to 2X setting	—	$(VRH - VRL)/4$	V
$DIFF_{max4}$	CC	C		PREGAIN set to 4X setting	—	$(VRH - VRL)/8$	V
$DIFF_{cmv}$	CC	C	Differential input Common mode voltage (DANx- + DANx+)/2 ⁵	—	$(V_{RH} + V_{RL})/2 - 5\%$	$(V_{RH} + V_{RL})/2 + 5\%$	V

¹ Applies only to differential channels.

² Variable gain is controlled by setting the PRE_GAIN bits in the ADC_ACR1-8 registers to select a gain factor of $\times 1$, $\times 2$, or $\times 4$. Settings are for differential input only. Tested at $\times 1$ gain. Values for other settings are guaranteed by as indicated.

³ At $V_{RH} - V_{RL} = 5.12$ V, one LSB = 1.25 mV.

⁴ Guaranteed 10-bit mono tonicity.

⁵ Voltages between VRL and VRH will not cause damage to the pins. However, they may not be converted accurately if the differential voltage is above the maximum differential voltage. In addition, conversion errors may occur if the common mode voltage of the differential signal violates the Differential Input common mode voltage specification.

3.13 Configuring SRAM wait states

Use the SWSC field in the ECSM_MUDCR register to specify an additional wait state for the device SRAM. By default, no wait state is added.

Table 30. Cutoff frequency for additional SRAM wait state

1	SWSC Value
98	0
153	1

¹ Max frequencies including 2% PLL FM.

Please see the device reference manual for details.

3.14 Platform flash controller electrical characteristics

Table 31. APC, RWSC, WWSC settings vs. frequency of operation¹

Max. Flash Operating Frequency (MHz) ²	APC ³	RWSC ³	WWSC
20 MHz	0b000	0b000	0b01
61 MHz	0b001	0b001	0b01
90 MHz	0b010	0b010	0b01
123 MHz	0b011	0b011	0b01
153 MHz	0b100	0b100	0b01

¹ APC, RWSC and WWSC are fields in the flash memory BIUCR register used to specify wait states for address pipelining and read/write accesses. Illegal combinations exist—all entries must be taken from the same row.

² Max frequencies including 2% PLL FM.

³ APC must be equal to RWSC.

3.15 Flash memory electrical characteristics

Table 32. Flash program and erase specifications¹

#	Symbol	C	Parameter	Value				Unit
				Min	Typ	Initial max ²	Max ³	
1	T _{dwprogram}	CC	C	Double Word (64 bits) Program Time				μs
2	T _{pprogram}	CC	C	Page Program Time ⁴				μs
3	T _{16kpperase}	CC	C	16 KB Block Pre-program and Erase Time				ms
5	T _{64kpperase}	CC	C	64 KB Block Pre-program and Erase Time				ms
6	T _{128kpperase}	CC	C	128 KB Block Pre-program and Erase Time				ms
7	T _{256kpperase}	CC	C	256 KB Block Pre-program and Erase Time				ms
8	T _{psrt}	SR	—	Program suspend request rate ⁵				μs
9	T _{esrt}	SR	—	Erase suspend request rate ⁶				ms

¹ Typical program and erase times assume nominal supply values and operation at 25 °C. All times are subject to change pending device characterization.

² Initial factory condition: ≤ 100 program/erase cycles, 25 °C, typical supply voltage, 80 MHz minimum system frequency.

³ The maximum erase time occurs after the specified number of program/erase cycles. This maximum value is characterized but not guaranteed.

⁴ Page size is 128 bits (4 words)

⁵ Time between program suspend resume and the next program suspend request.

⁶ Time between erase suspend resume and the next erase suspend request.

Table 33. Flash EEPROM module life

Symbol		C	Parameter	Conditions	Value		Unit
					Min	Typ	
P/E	CC	D	Number of program/erase cycles per block for 16 KB, 48 KB, and 64 KB blocks over the operating temperature range (T _J)	—	100,000	—	cycles
P/E	CC	D	Number of program/erase cycles per block for 128 KB and 256 KB blocks over the operating temperature range (T _J)	—	1,000	100,000	cycles
Retention	CC	D	Minimum data retention at 85 °C	Blocks with 0 – 1,000 P/E cycles	20	—	years
		D		Blocks with 10,000 P/E cycles	10	—	
		D		Blocks with 100,000 P/E cycles	5	—	

3.16 AC specifications

3.16.1 Pad AC specifications

 Table 34. Pad AC specifications ($V_{DDE} = 4.75 \text{ V}$)¹

Name	C	D	Output delay (ns) ^{2,3} Low-to-High / High-to-Low		Rise/Fall edge (ns) ^{3,4}		Drive load (pF)	SRC/DSC
			Min	Max	Min	Max		MSB, LSB
Medium ^{5,6,7}	CC	D	4.6/3.7	12/12	2.2/2.2	12/12	50	11 ⁸
	—							10 ⁹
	CC	D	12/13	28/34	5.6/6	15/15	50	01
Slow ^{7,10}	CC	D	69/71	152/165	34/35	74/74	50	00
	—							10 ⁹
	CC	D	26/27	61/69	13/13	34/34	50	01
MultiV ¹¹ (High Swing Mode)	CC	D	137/142	320/330	72/74	164/164	50	00
	—							10 ⁹
	CC	D	4.1/3.6	10.3/8.9	3.28/2.98	8/8	50	11 ⁸
MultiV (Low Swing Mode)	CC	D	8.38/6.11	16/12.9	5.48/4.81	11/11	50	01
	CC	D	61.7/10.4	92.2/24.3	42.0/12.2	63/63	50	00
Fast ¹²	—							11 ⁸
Standalone input buffer ¹³	CC	D	2.31/2.34	7.62/6.33	1.26/1.67	6.5/4.4	30	—
			0.5/0.5	1.9/1.9	0.3/0.3	±1.5/1.5	0.5	—

¹ These are worst case values that are estimated from simulation and not tested. The values in the table are simulated at $V_{DD} = 1.14 \text{ V}$ to 1.32 V , $V_{DDEH} = 4.75 \text{ V}$ to 5.25 V , $T_A = T_L$ to T_H .

² This parameter is supplied for reference and is not guaranteed by design and not tested.

³ Delay and rise/fall are measured to 20% or 80% of the respective signal.

⁴ This parameter is guaranteed by characterization before qualification rather than 100% tested.

⁵ In high swing mode, high/low swing pad V_{OL} and V_{OH} values are the same as those of the slew controlled output pads.

⁶ Medium Slew-Rate Controlled Output buffer. Contains an input buffer and weak pull-up/pull-down.

⁷ Output delay is shown in [Figure 9](#) and [Figure 10](#). Add a maximum of one system clock to the output delay for delay with respect to system clock.

⁸ Can be used on the tester

⁹ This drive select value is not supported. If selected, it will be approximately equal to 11.

¹⁰ Slow Slew-Rate Controlled Output buffer. Contains an input buffer and weak pull-up/pull-down.

¹¹ Selectable high/low swing I/O pad with selectable slew in high swing mode only

¹² Fast pads are 3.3 V pads.

¹³ Also has weak pull-up/pull-down.

Table 35. Pad AC specifications ($V_{DDE} = 3.0\text{ V}$)¹

Pad type	C	D	Output delay (ns) ^{2,3} Low-to-High / High-to-Low		Rise/Fall edge (ns) ^{3,4}		Drive load (pF)	SRC/DSC
			Min	Max	Min	Max		MSB,LSB
Medium ^{5,6,7}	CC	D	5.8/4.4	18/17	2.7/2.1	10/10	50	11 ⁸
	CC	D	16/13	46/49	11.2/8.6	34/34	200	
	—							10 ⁹
	CC	D	14/16	37/45	6.5/6.7	19/19	50	01
	CC	D	27/27	69/82	15/13	43/43	200	
	CC	D	83/86	200/210	38/38	86/86	50	00
	CC	D	113/109	270/285	53/46	120/120	200	
Slow ^{7,10}	CC	D	9.2/6.9	27/28	5.5/4.1	20/20	50	11
	CC	D	30/23	81/87	21/16	63/63	200	
	—							10 ⁹
	CC	D	31/31	80/90	15.4/15.4	42/42	50	01
	CC	D	58/52	144/155	32/26	82/85	200	
	CC	D	162/168	415/415	80/82	190/190	50	00
	CC	D	216/205	533/540	106/95	250/250	200	
MultiV ^{7,11} (High Swing Mode)	CC	D	—	3.7/3.1	—	10/10	30	11 ⁸
	CC	D	—	46/49	—	42/42	200	
	—							10 ⁹
	CC	D	—	32	—	15/15	50	01
	CC	D	—	72	—	46/46	200	
	CC	D	—	210	—	100/100	50	00
	CC	D	—	295	—	134/134	200	
MultiV (Low Swing Mode)	Not a valid operational mode							
Fast	CC	D	—	2.5/2.5	—	1.2/1.2	10	00
	CC	D	—	2.5/2.5	—	1.2/1.2	20	01
	CC	D	—	2.5/2.5	—	1.2/1.2	30	10
	CC	D	—	2.5/2.5	—	1.2/1.2	50	11 ⁸
Standalone input buffer ¹²	CC	D	0.5/0.5	3/3	0.4/0.4	±1.5/1.5	0.5	—

¹ These are worst case values that are estimated from simulation and not tested. The values in the table are simulated at $V_{DD} = 1.14\text{ V}$ to 1.32 V , $V_{DDE} = 3\text{ V}$ to 3.6 V , $V_{DDEH} = 3\text{ V}$ to 3.6 V , $T_A = T_L$ to T_H .

² This parameter is supplied for reference and is not guaranteed by design and not tested.

³ Delay and rise/fall are measured to 20% or 80% of the respective signal.

⁴ This parameter is guaranteed by characterization before qualification rather than 100% tested.

Electrical characteristics

- ⁵ In high swing mode, high/low swing pad V_{OL} and V_{OH} values are the same as those of the slew controlled output pads.
- ⁶ Medium Slew-Rate Controlled Output buffer. Contains an input buffer and weak pull-up/pull-down.
- ⁷ Output delay is shown in [Figure 9](#) and [Figure 10](#). Add a maximum of one system clock to the output delay for delay with respect to system clock.
- ⁸ Can be used on the tester.
- ⁹ This drive select value is not supported. If selected, it will be approximately equal to 11.
- ¹⁰ Slow Slew-Rate Controlled Output buffer. Contains an input buffer and weak pull-up/pull-down.
- ¹¹ Selectable high/low swing I/O pad with selectable slew in high swing mode only.
- ¹² Also has weak pull-up/pull-down.

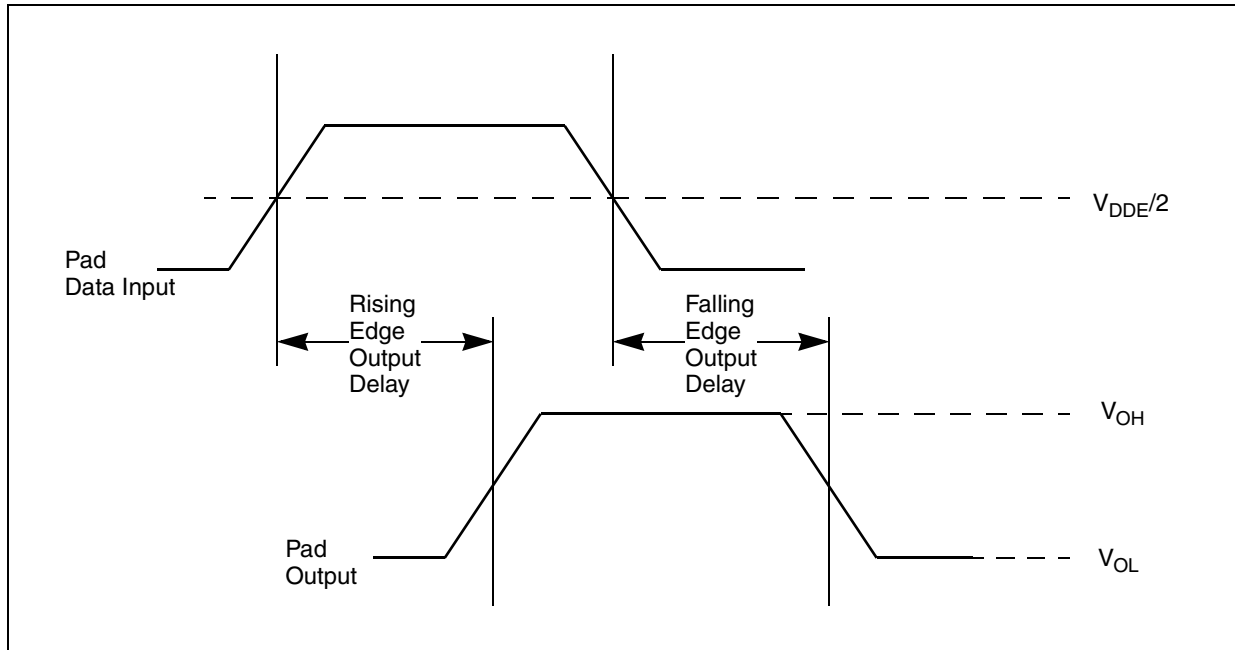

Figure 9. Pad output delay—Fast pads

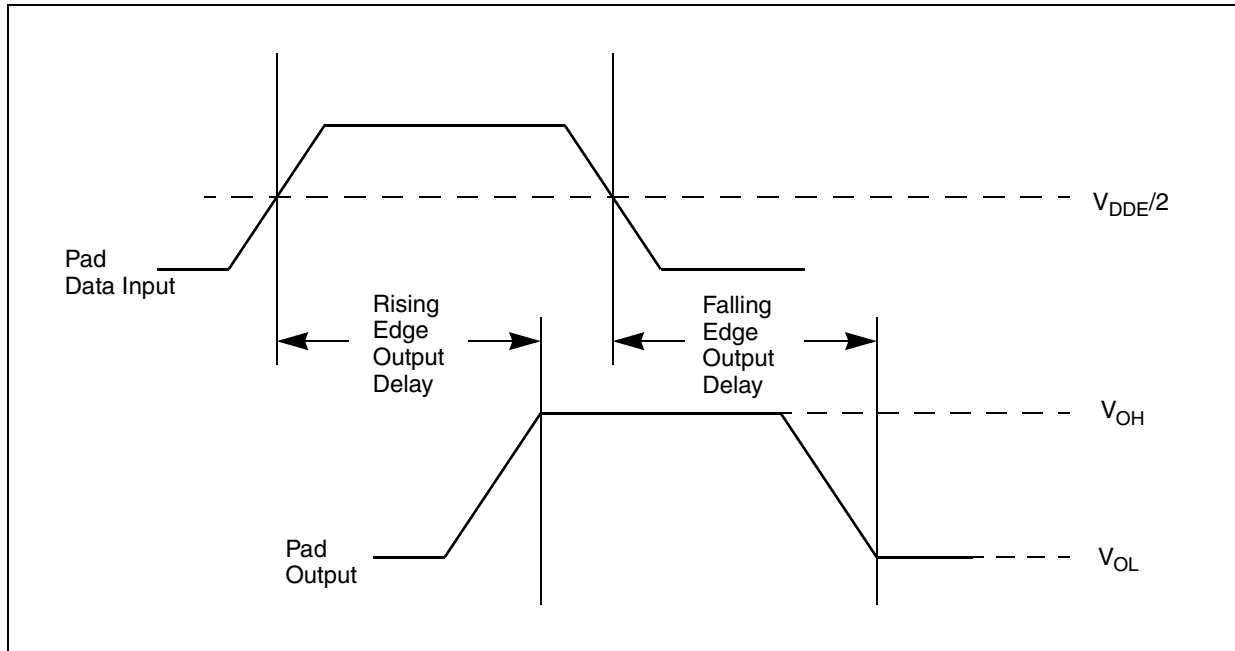

Figure 10. Pad output delay—Slew rate controlled fast, medium, and slow pads

3.17 AC timing

3.17.1 Reset and configuration pin timing

Table 36. Reset and configuration pin timing¹

#	Symbol	Characteristic	Value		Unit
			Min	Max	
1	t_{RPW}	\overline{RESET} Pulse Width	10	—	t_{CYC}
2	t_{GPW}	\overline{RESET} Glitch Detect Pulse Width	2	—	t_{CYC}
3	t_{RCSU}	PLLREF, BOOTCFG, WKPCFG Setup Time to \overline{RSTOUT} Valid	10	—	t_{CYC}
4	t_{RCH}	PLLREF, BOOTCFG, WKPCFG Hold Time to \overline{RSTOUT} Valid	0	—	t_{CYC}

¹ Reset timing specified at: $V_{DDEH} = 3.0\text{ V to }5.25\text{ V}$, $V_{DD} = 1.14\text{ V to }1.32\text{ V}$, $T_A = T_L\text{ to }T_H$.

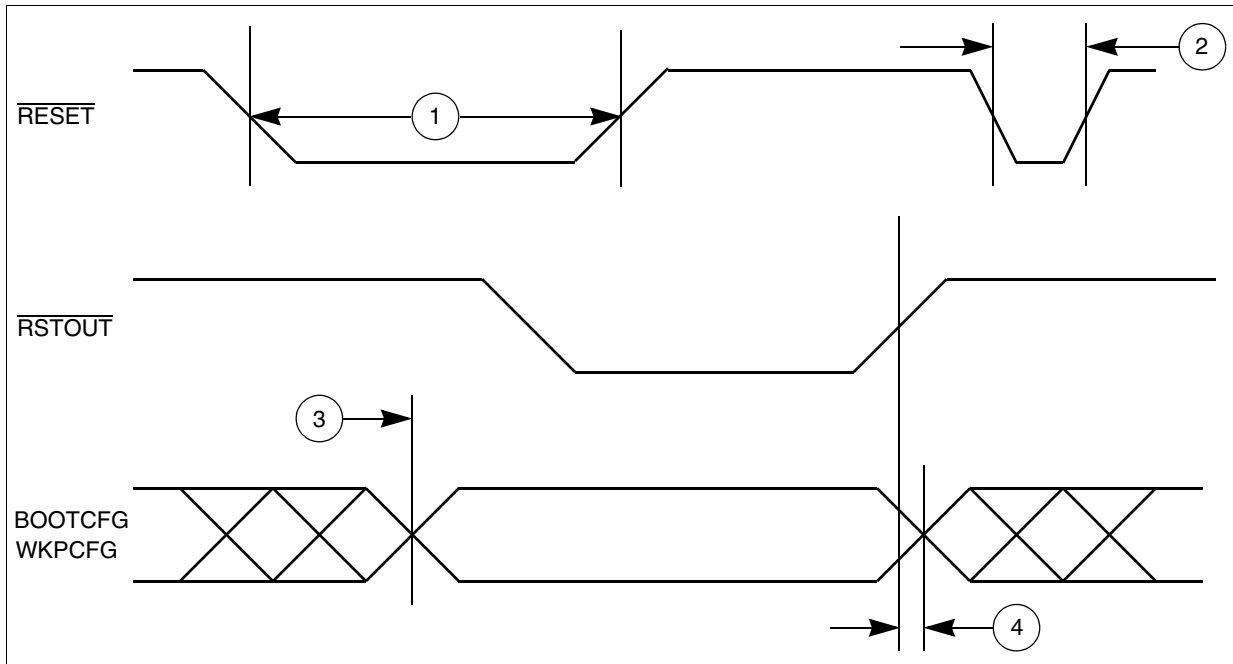

Figure 11. Reset and configuration pin timing

3.17.2 IEEE 1149.1 interface timing

Table 37. JTAG pin AC electrical characteristics¹

#	Symbol	C	Characteristic	Value		Unit
				Min	Max	
1	t_{JCYC}	CC	D TCK Cycle Time	100	—	ns
2	t_{JDC}	CC	D TCK Clock Pulse Width	40	60	ns
3	$t_{TCKRISE}$	CC	D TCK Rise and Fall Times (40%–70%)	—	3	ns

Table 37. JTAG pin AC electrical characteristics¹ (continued)

#	Symbol	C	Characteristic	Value		Unit	
				Min	Max		
4	t_{TMSS}, t_{TDIS}	CC	D	TMS, TDI Data Setup Time	10	—	ns
5	t_{TMSH}, t_{TDIH}	CC	D	TMS, TDI Data Hold Time	25	—	ns
6	t_{TDOV}	CC	D	TCK Low to TDO Data Valid	—	22 ²	ns
7	t_{TDOI}	CC	D	TCK Low to TDO Data Invalid	0	—	ns
8	t_{TDOHZ}	CC	D	TCK Low to TDO High Impedance	—	22	ns
9	t_{JCMPPW}	CC	D	JCOMP Assertion Time	100	—	ns
10	t_{JCMPS}	CC	D	JCOMP Setup Time to TCK Low	40	—	ns
11	t_{BSDV}	CC	D	TCK Falling Edge to Output Valid	—	50	ns
12	t_{BSDVZ}	CC	D	TCK Falling Edge to Output Valid out of High Impedance	—	50	ns
13	t_{BSDHZ}	CC	D	TCK Falling Edge to Output High Impedance	—	50	ns
14	t_{BSDST}	CC	D	Boundary Scan Input Valid to TCK Rising Edge	25 ³	—	ns
15	t_{BSDHT}	CC	D	TCK Rising Edge to Boundary Scan Input Invalid	25 ³	—	ns

¹ JTAG timing specified at $V_{DD} = 1.14\text{ V to }1.32\text{ V}$, $V_{DDEH} = 4.75\text{ V to }5.25\text{ V}$ with multi-voltage pads programmed to Low-Swing mode, $T_A = T_L$ to T_H , $C_L = 30\text{ pF}$, $SRC = 0b11$. These specifications apply to JTAG boundary scan only. See [Table 38](#) for functional specifications.

² Pad delay is 8–10 ns. Remainder includes TCK pad delay, clock tree delay logic delay and TDO output pad delay.

³ For 20 MHz TCK.

NOTE

The Nexus/JTAG Read/Write Access Control/Status Register (RWCS) write (to begin a read access) or the write to the Read/Write Access Data Register (RWD) (to begin a write access) does not actually begin its action until 1 JTAG clock (TCK) after leaving the JTAG Update-DR state. This prevents the access from being performed and therefore will not signal its completion via the READY (RDY) output unless the JTAG controller receives an additional TCK. In addition, \overline{EVTI} is not latched into the device unless there are clock transitions on TCK.

The tool/debugger must provide at least one TCK clock for the \overline{EVTI} signal to be recognized by the MCU. When using the RDY signal to indicate the end of a Nexus read/write access, ensure that TCK continues to run for at least one TCK after leaving the Update-DR state. This can be just a TCK with TMS low while in the Run-Test/Idle state or by continuing with the next Nexus/JTAG command. Expect the effect of \overline{EVTI} and RDY to be delayed by edges of TCK.

RDY is not available in all device packages.

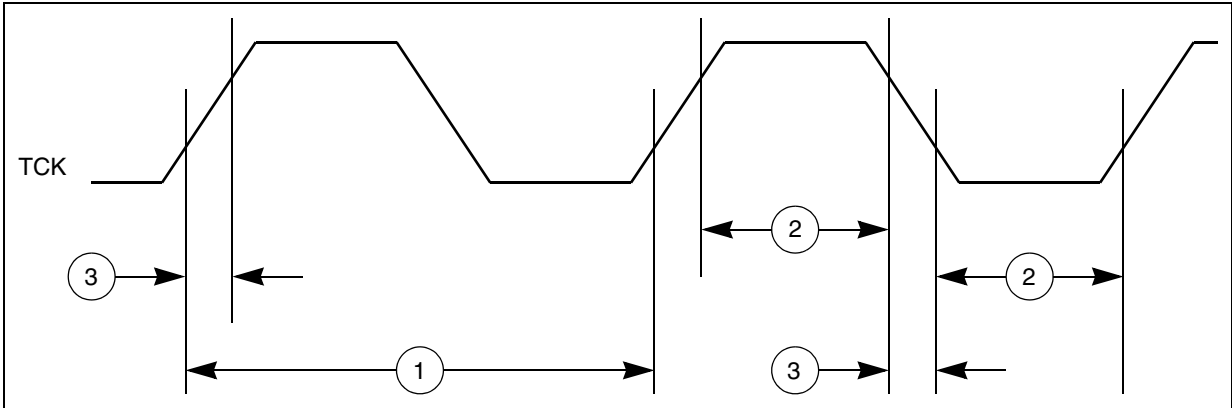

Figure 12. JTAG test clock input timing

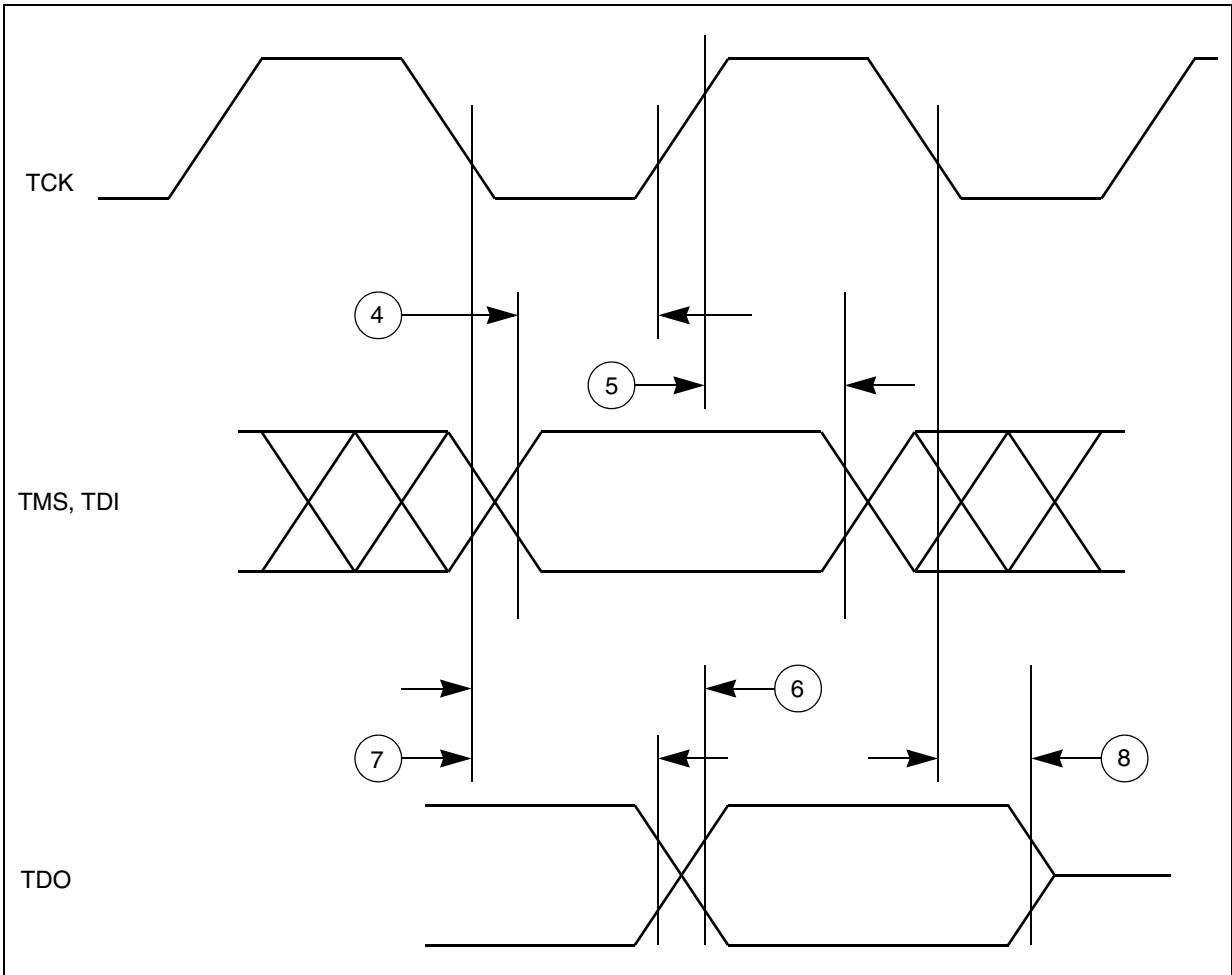

Figure 13. JTAG test access port timing

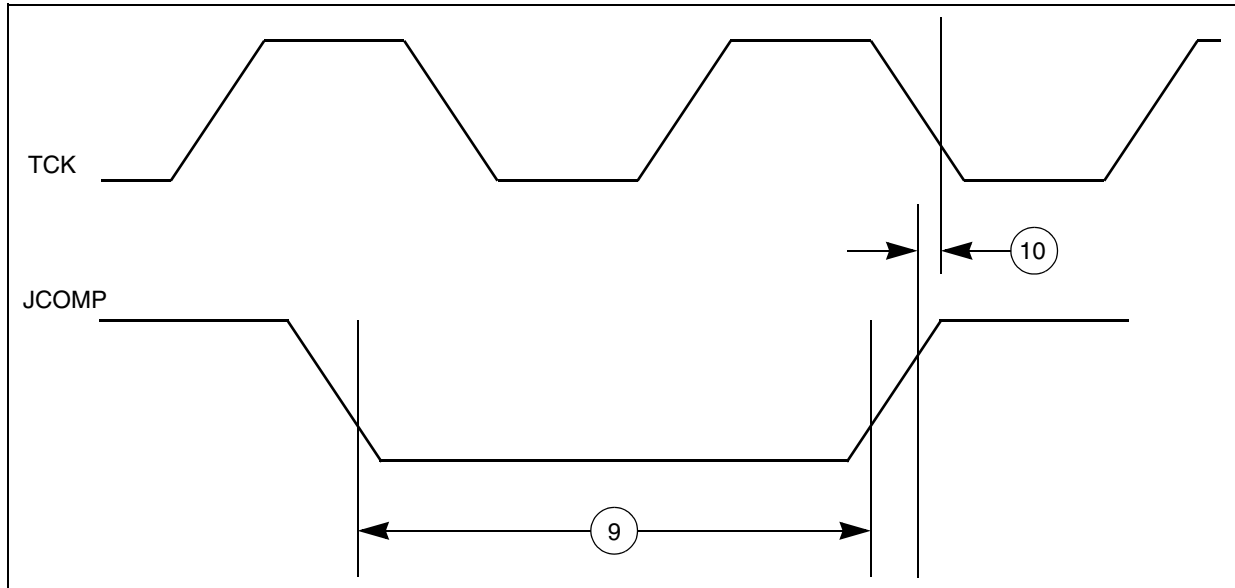

Figure 14. JTAG JCOMP timing

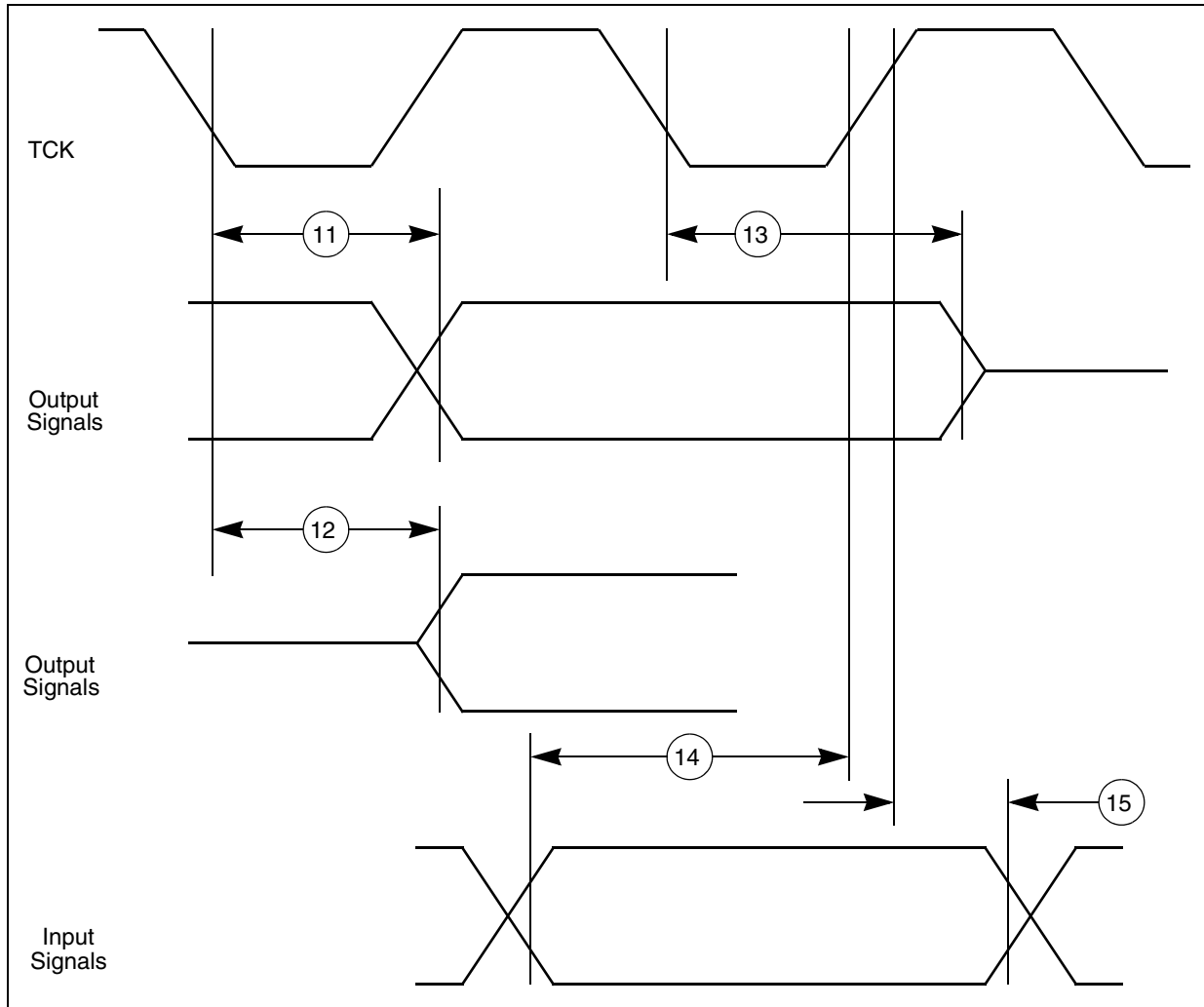

Figure 15. JTAG boundary scan timing

3.17.3 Nexus timing

Table 38. Nexus debug port timing¹

#	Symbol	C	Characteristic	Value		Unit	
				Min	Max		
1	t_{MCCY}	CC	D	MCKO Cycle Time	2 ^{2,3}	8	t_{CYC}
1a	t_{MCCY}	CC	D	Absolute Minimum MCKO Cycle Time	25 ⁴	—	ns
2	t_{MDC}	CC	D	MCKO Duty Cycle	40	60	%
3	t_{MDOV}	CC	D	MCKO Low to MDO Data Valid ⁵	-0.1	0.35	t_{MCCY}
4	t_{MSEOV}	CC	D	MCKO Low to \overline{MSEO} Data Valid ⁵	-0.1	0.35	t_{MCCY}
6	$t_{EVT OV}$	CC	D	MCKO Low to $\overline{EVT O}$ Data Valid ⁵	-0.1	0.35	t_{MCCY}
7	t_{EVTIPW}	CC	D	\overline{EVTI} Pulse Width	4.0	—	t_{CYC}

Table 38. Nexus debug port timing¹ (continued)

#	Symbol	C	Characteristic	Value		Unit	
				Min	Max		
8	t_{EVTOPW}	CC	D	$\overline{EVT0}$ Pulse Width	1	—	t_{MCCYC}
9	t_{TCYC}	CC	D	TCK Cycle Time	4 ^{6,7}	—	t_{CYC}
9a	t_{TCYC}	CC	D	Absolute Minimum TCK Cycle Time	100 ⁸	—	ns
10	t_{TDC}	CC	D	TCK Duty Cycle	40	60	%
11	t_{NTDIS}	CC	D	TDI Data Setup Time	10	—	ns
12	t_{NTDIH}	CC	D	TDI Data Hold Time	25	—	ns
13	t_{NTMSS}	CC	D	TMS Data Setup Time	10	—	ns
14	t_{NTMSH}	CC	D	TMS Data Hold Time	25	—	ns
15	—	CC	D	TDO propagation delay from falling edge of TCK	—	19.5	ns
16	—	CC	D	TDO hold time wrt TCK falling edge (minimum TDO propagation delay)	5.25	—	ns

¹ All Nexus timing relative to MCKO is measured from 50% of MCKO and 50% of the respective signal. Nexus timing specified at $V_{DD} = 1.14$ V to 1.32 V, $V_{DDEH} = 4.75$ V to 5.25 V with multi-voltage pads programmed to Low-Swing mode, $T_A = T_L$ to T_H , and $C_L = 30$ pF with DSC = 0b10.

² Achieving the absolute minimum MCKO cycle time may require setting the MCKO divider to more than its minimum setting (NPC_PCR[MCKO_DIV] depending on the actual system frequency being used.

³ This is a functionally allowable feature. However, this may be limited by the maximum frequency specified by the Absolute minimum MCKO period specification.

⁴ This may require setting the MCO divider to more than its minimum setting (NPC_PCR[MCKO_DIV]) depending on the actual system frequency being used.

⁵ MDO, $\overline{MSE0}$, and $\overline{EVT0}$ data is held valid until next MCKO low cycle.

⁶ Achieving the absolute minimum TCK cycle time may require a maximum clock speed (system frequency / 8) that is less than the maximum functional capability of the design (system frequency / 4) depending on the actual system frequency being used.

⁷ This is a functionally allowable feature. However, this may be limited by the maximum frequency specified by the Absolute minimum TCK period specification.

⁸ This may require a maximum clock speed (system frequency / 8) that is less than the maximum functional capability of the design (system frequency / 4) depending on the actual system frequency being used.

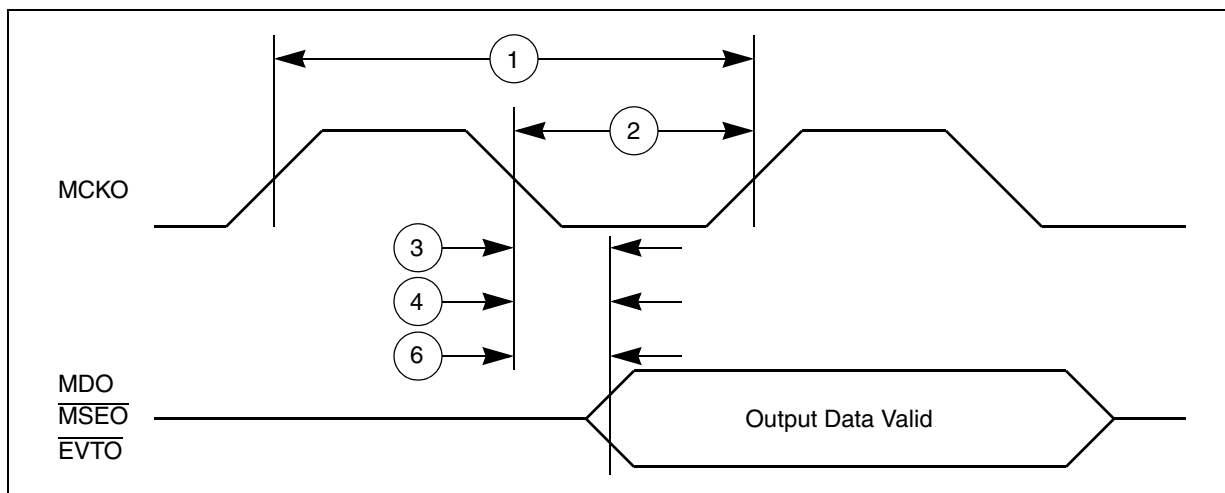

Figure 16. Nexus output timing

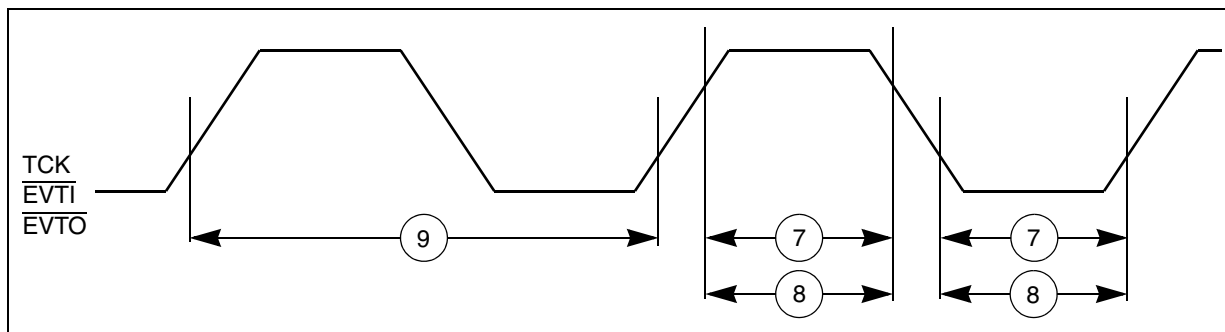

Figure 17. Nexus event trigger and test clock timings

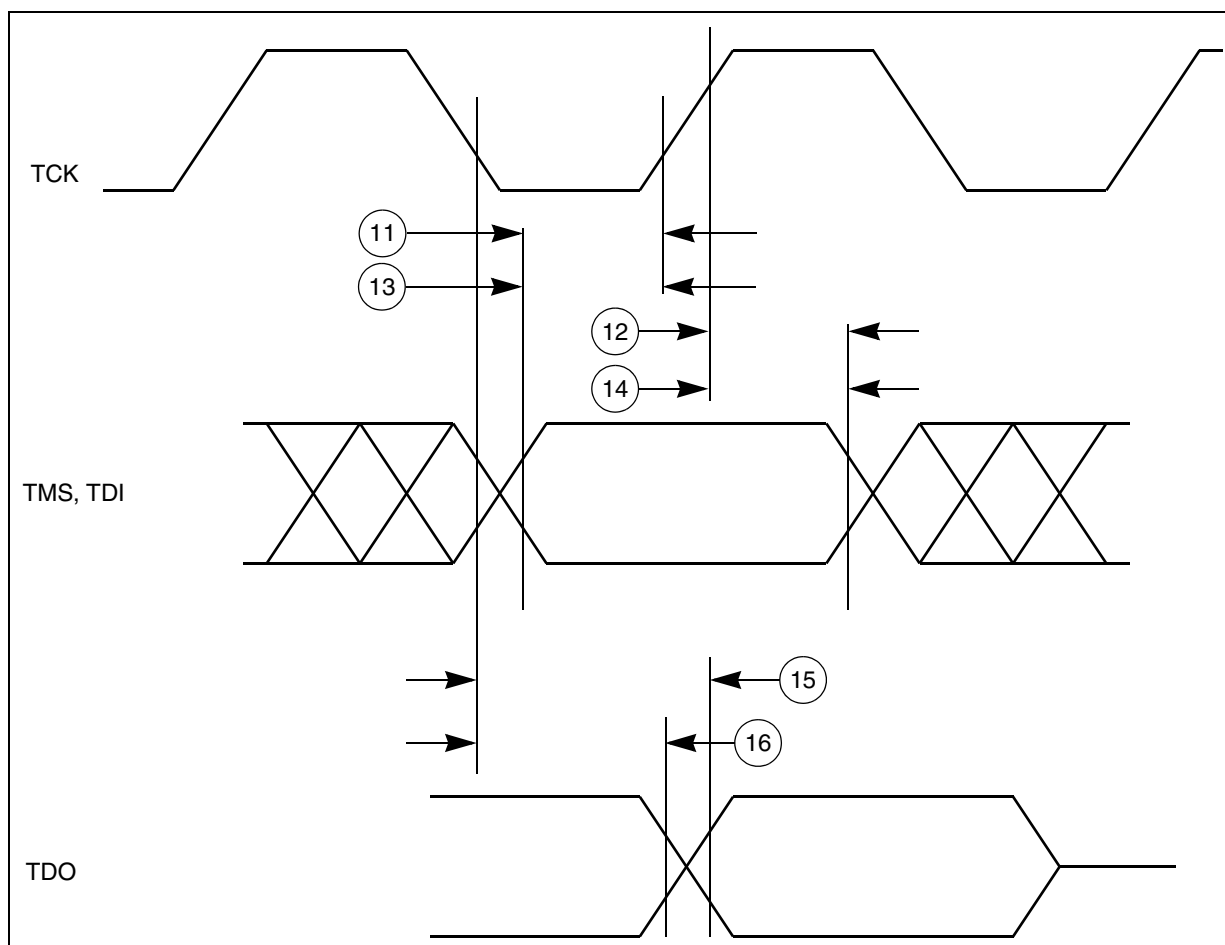

Figure 18. Nexus TDI, TMS, TDO timing

Table 39. Nexus debug port operating frequency

Package	Nexus Width	Nexus Routing	Nexus Pin Usage			Max. Operating Frequency
			MDO[0:3]	MDO[4:11]	CAL_MDO[4:11]	
176 LQFP 208 BGA 324 BGA	Reduced port mode ¹	Route to MDO ²	Nexus Data Out [0:3]	GPIO	GPIO	40 MHz ³
	Full port mode ⁴	Route to MDO ²	Nexus Data Out [0:3]	Nexus Data Out [4:11]	GPIO	40 MHz ^{5,6}
496 CSP	Reduced port mode ¹	Route to MDO ²	Nexus Data Out [0:3]	GPIO	GPIO	40 MHz ³
	Full port mode ⁴	Route to MDO ²	Nexus Data Out [0:3]	Nexus Data Out [4:11]	GPIO	40 MHz ^{5,6}
		Route to CAL_MDO ⁷	Cal Nexus Data Out [0:3]	GPIO	Cal Nexus Data Out [4:11]	40 MHz ³

¹ NPC_PCR[FPM] = 0

² NPC_PCR[NEXCFG] = 0

Electrical characteristics

- ³ The Nexus AUX port runs up to 40 MHz. Set NPC_PCR[MCKO_DIV] to divide-by-two if the system frequency is greater than 40 MHz.
- ⁴ NPC_PCR[FPM] = 1
- ⁵ Set the NPC_PCR[MCKO_DIV] to divide by two if the system frequency is between 40 MHz and 80 MHz inclusive. Set the NPC_PCR[MCKO_DIV] to divide by four if the system frequency is greater than 80 MHz.
- ⁶ Pad restrictions limit the Maximum Operation Frequency in these configurations
- ⁷ NPC_PCR[NEXCFG] = 1

3.17.4 Calibration bus interface timing

Table 40. Calibration bus interface maximum operating frequency

Port width	Multiplexed mode	Pin usage			Max. operating frequency
		CAL_ADDR[12:15]	CAL_ADDR[16:30]	CAL_DATA[0:15]	
16-bit	Yes	GPIO	GPIO	CAL_ADDR[12:30] CAL_DATA[0:15]	66 MHz ¹
16-bit	No	CAL_ADDR[12:15]	CAL_ADDR[16:30]	CAL_DATA[0:15]	66 MHz ¹
32-bit	Yes	CAL_WE/BE[2:3] CAL_DATA[31]	CAL_ADDR[16:30] CAL_DATA[16:30]	CAL_ADDR[0:15] CAL_DATA[0:15]	66 MHz ¹

¹ Set SIU_ECCR[EBDF] to either divide by two or divide by four if the system frequency is greater than 66 MHz.

Table 41. Calibration bus operation timing¹

#	Symbol	C	Characteristic	66 MHz ²		Unit	
				Min	Max		
1	T _C	CC	P	CLKOUT period ³	15.2	—	ns
2	t _{CDC}	CC	T	CLKOUT duty cycle	45%	55%	T _C
3	t _{CRT}	CC	T	CLKOUT rise time	—	4	ns
4	t _{CFT}	CC	T	CLKOUT fall time	—	4	ns
5	t _{COH}	CC	P	CLKOUT Posedge to Output Signal Invalid or High Z (Hold Time) CAL_ADDR[12:30] CAL_CS[0], CAL_CS[2:3] CAL_DATA[0:15] CAL_OE CAL_RD_W \overline{R} CAL_TS CAL_W \overline{E} [0:3]/B \overline{E} [0:3]	1.3	—	ns
6	t _{COV}	CC	P	CLKOUT Posedge to Output Signal Valid (Output Delay) CAL_ADDR[12:30] CAL_CS[0], CAL_CS[2:3] CAL_DATA[0:15] CAL_OE CAL_RD_W \overline{R} CAL_TS CAL_W \overline{E} [0:3]/B \overline{E} [0:3]	—	9	ns
7	t _{CIS}	CC	P	Input Signal Valid to CLKOUT Posedge (Setup Time) DATA[0:31]	6.0	—	ns
8	t _{CIH}	CC	P	CLKOUT Posedge to Input Signal Invalid (Hold Time) DATA[0:31]	1.0	—	ns
9	t _{APW}	CC	P	ALE Pulse Width ⁵	6.5	—	ns
10	t _{AAI}	CC	P	ALE Negated to Address Invalid ⁵	1.5 ⁶	—	ns

Electrical characteristics

- ¹ Calibration bus timing specified at $f_{SYS} = 150 \text{ MHz}$ and 100 MHz , $V_{DD} = 1.14 \text{ V}$ to 1.32 V , $V_{DDE} = 3 \text{ V}$ to 3.6 V (unless stated otherwise), $T_A = T_L$ to T_H , and $C_L = 30 \text{ pF}$ with $DSC = 0b10$.
- ² The calibration bus is limited to half the speed of the internal bus. The maximum calibration bus frequency is 66 MHz . The bus division factor should be set accordingly based on the internal frequency being used.
- ³ Signals are measured at $50\% V_{DDE}$
- ⁴ Refer to fast pad timing in [Table 34](#) and [Table 35](#) (different values for 1.8 V vs. 3.3 V).
- ⁵ Measured at 50% of ALE
- ⁶ When CAL_TS pad is used for CAL_ALE function the hold time is 1 ns instead of 1.5 ns .

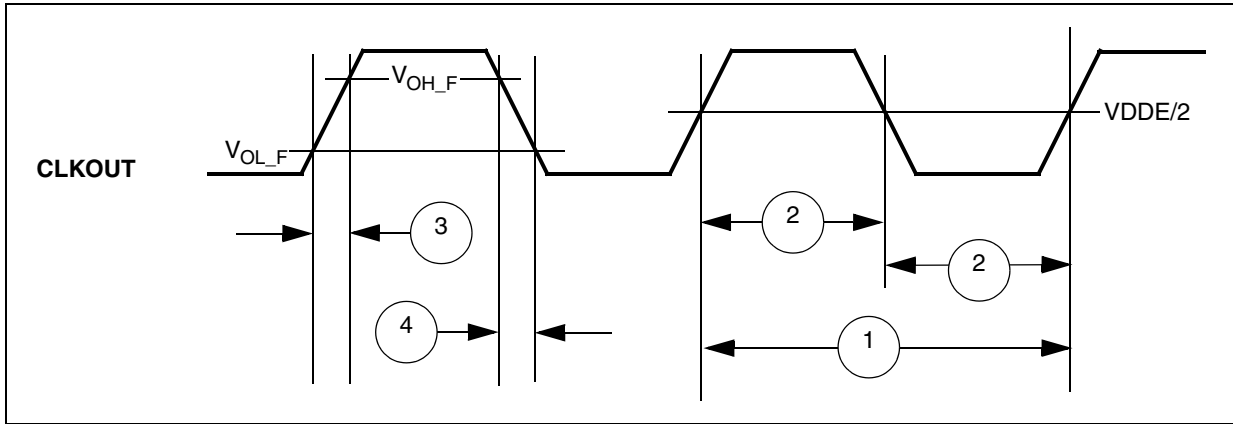

Figure 19. CLKOUT timing

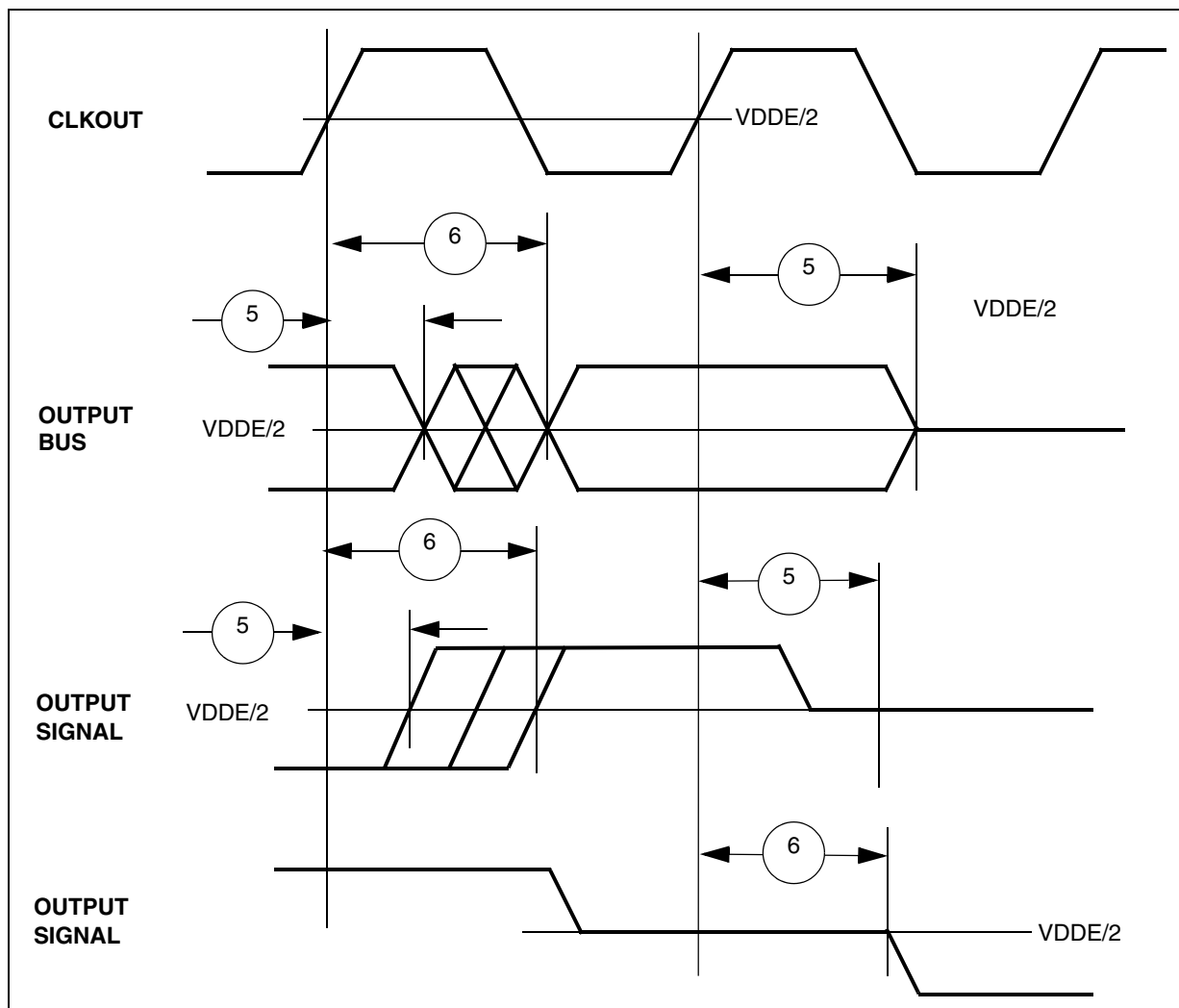

Figure 20. Synchronous output timing

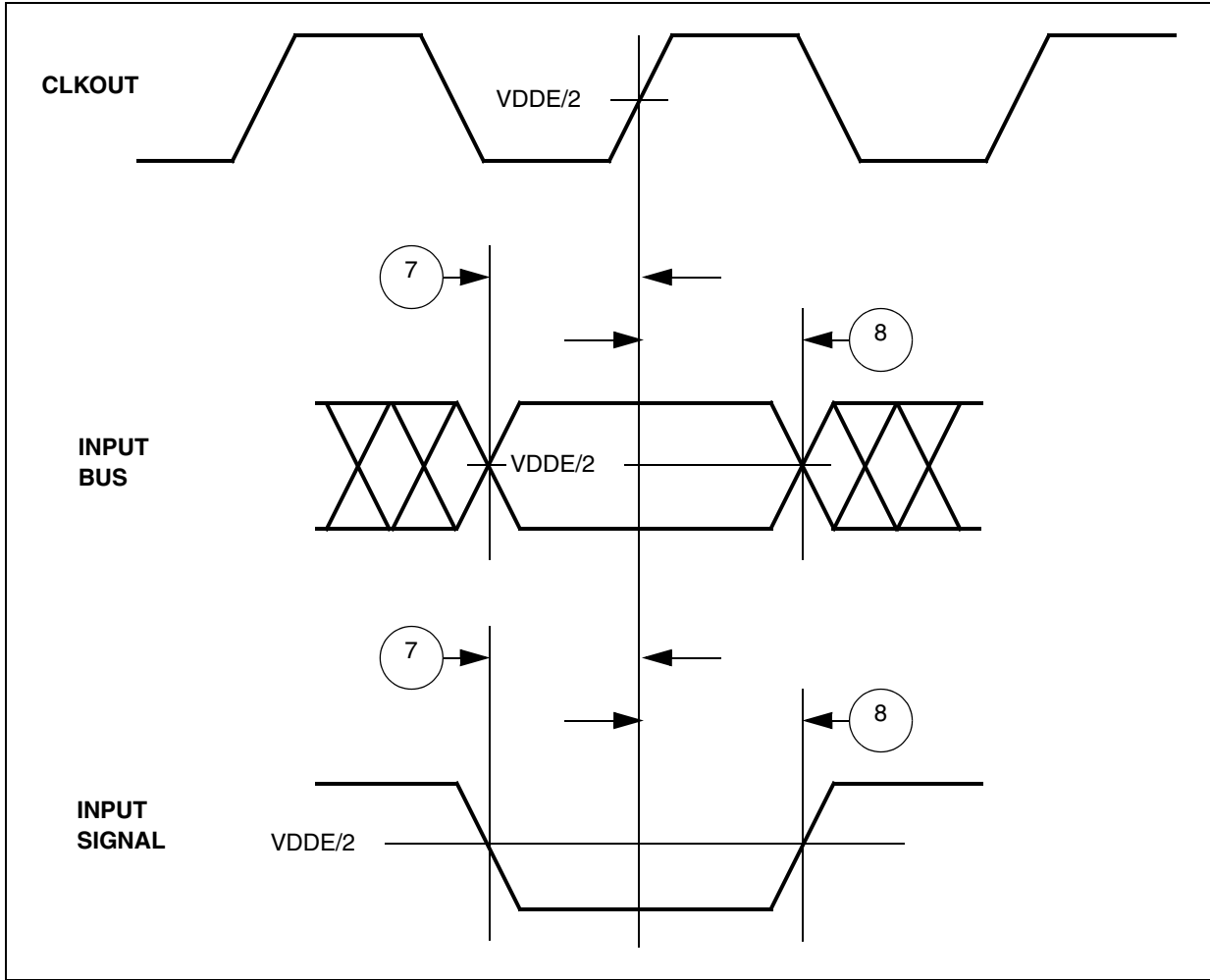

Figure 21. Synchronous input timing

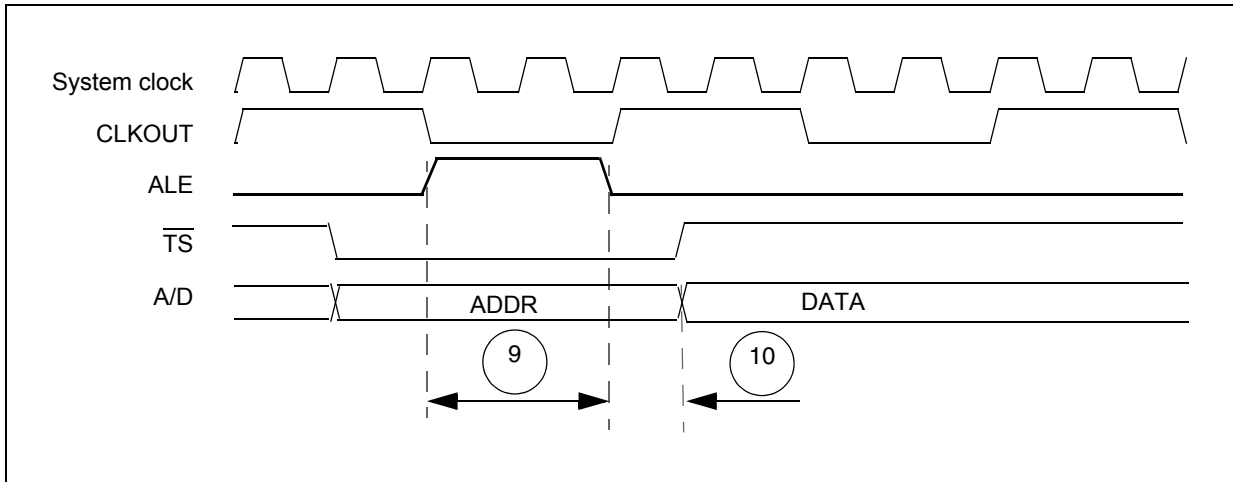

Figure 22. ALE signal timing

3.17.5 External interrupt timing (IRQ pin)

Table 42. External interrupt timing¹

#	Symbol	Characteristic	Value		Unit
			Min	Max	
1	t_{IPWL}	IRQ Pulse Width Low	3	—	t_{CYC}
2	t_{IPWH}	IRQ Pulse Width High	3	—	t_{CYC}
3	t_{ICYC}	IRQ Edge to Edge Time ²	6	—	t_{CYC}

¹ IRQ timing specified at $V_{DD} = 1.14\text{ V to }1.32\text{ V}$, $V_{DDEH} = 3.0\text{ V to }5.25\text{ V}$, V_{DD33} and $V_{DDSYN} = 3.0\text{ V to }3.6\text{ V}$, $T_A = T_L$ to T_H .

² Applies when IRQ pins are configured for rising edge or falling edge events, but not both.

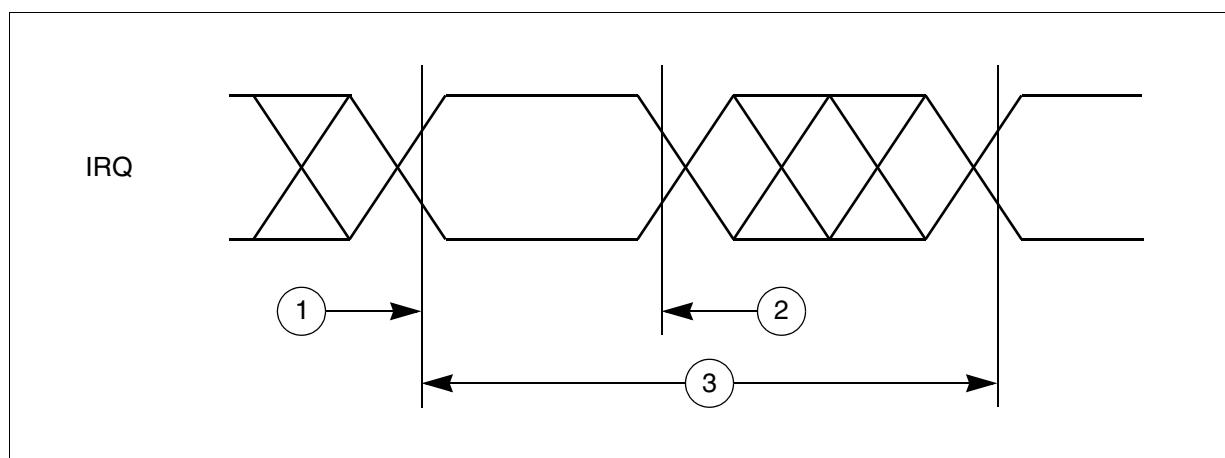
Figure 23. External interrupt timing

3.17.6 eTPU timing

Table 43. eTPU timing¹

#	Symbol	Characteristic	Value		Unit
			Min	Max	
1	t_{ICPW}	eTPU Input Channel Pulse Width	4	—	t_{CYC}
2	t_{OCPW}	eTPU Output Channel Pulse Width ²	2	—	t_{CYC}

¹ eTPU timing specified at $V_{DD} = 1.14\text{ V to }1.32\text{ V}$, $V_{DDEH} = 3.0\text{ V to }5.25\text{ V}$, V_{DD33} and $V_{DDSYN} = 3.0\text{ V to }3.6\text{ V}$, $T_A = T_L$ to T_H , and $C_L = 50\text{ pF}$ with $SRC = 0b00$.

² This specification does not include the rise and fall times. When calculating the minimum eTPU pulse width, include the rise and fall times defined in the slew rate control fields (SRC) of the pad configuration registers (PCR).

3.17.7 eMIOS timing

Table 44. eMIOS timing¹

#	Symbol	C	Characteristic	Value		Unit	
				Min	Max		
1	t_{MIPW}	CC	D	eMIOS Input Pulse Width	4	—	t_{CYC}
2	t_{MOPW}	CC	D	eMIOS Output Pulse Width	1	—	t_{CYC}

¹ eMIOS timing specified at $V_{DD} = 1.14$ V to 1.32 V, $V_{DDEH} = 4.75$ V to 5.25 V, $T_A = T_L$ to T_H , and $C_L = 50$ pF with SRC = 0b00.

3.17.8 DSPI timing

DSPI channel frequency support for the MPC5642A MCU is shown in [Table 45](#). Timing specifications are in [Table 46](#).

Table 45. DSPI channel frequency support

System clock (MHz)	DSPI Use Mode	Maximum usable frequency (MHz)	Notes
150	LVDS	37.5	Use sysclock /4 divide ratio
	Non-LVDS	18.75	Use sysclock /8 divide ratio
120	LVDS	40	Use sysclock /3 divide ratio. Gives 33/66 duty cycle. Use DSPI configuration DBR = 0b1 (double baud rate), BR = 0b0000 (scaler value 2) and PBR = 0b01 (prescaler value 3).
	Non-LVDS	20	Use sysclock /6 divide ratio
80	LVDS	40	Use sysclock /2 divide ratio
	Non-LVDS	20	Use sysclock /4 divide ratio

Table 46. DSPI timing^{1,2}

#	Symbol	C	Characteristic	Condition	Min.	Max.	Unit
1	t_{SCK}	CC	D	SCK Cycle Time ^{3,4,5}	24.4 ns	2.9 ms	—
2	t_{CSC}	CC	D	PCS to SCK Delay ⁶	22 ⁷	—	ns
3	t_{ASC}	CC	D	After SCK Delay ⁸	21 ⁹	—	ns
4	t_{SDC}	CC	D	SCK Duty Cycle	$(\frac{1}{2}t_{SC}) - 2$	$(\frac{1}{2}t_{SC}) + 2$	ns
5	t_A	CC	D	Slave Access Time (\overline{SS} active to SOUT driven)	—	25	ns
6	t_{DIS}	CC	D	Slave SOUT Disable Time (\overline{SS} inactive to SOUT High-Z or invalid)	—	25	ns
7	t_{PCSC}	CC	D	PCSx to \overline{PCSS} time	4 ¹⁰	—	ns
8	t_{PASC}	CC	D	\overline{PCSS} to PCSx time	5 ¹¹	—	ns

Table 46. DSPI timing^{1,2} (continued)

#	Symbol	C	Characteristic	Condition	Min.	Max.	Unit	
9	t _{SUI}	CC	Data Setup Time for Inputs					
			D	Master (MTFE = 0)	V _{DDEH} =4.75–5.25 V	20	—	ns
			D		V _{DDEH} =3–3.6 V	22	—	
			D	Slave		2	—	
			D	Master (MTFE = 1, CPHA = 0) ¹²		8	—	
			D	Master (MTFE = 1, CPHA = 1)	V _{DDEH} =4.75–5.25 V	20	—	
			D		V _{DDEH} =3–3.6 V	22	—	
10	t _{HI}	CC	Data Hold Time for Inputs					
			D	Master (MTFE = 0)		–4	—	ns
			D	Slave		7	—	
			D	Master (MTFE = 1, CPHA = 0) ¹²		21	—	
			D	Master (MTFE = 1, CPHA = 1)		–4	—	
11	t _{SUO}	CC	Data Valid (after SCK edge)					
			D	Master (MTFE = 0)	V _{DDEH} =4.75–5.25 V	—	5	ns
			D		V _{DDEH} =3–3.6 V	—	6.3	
			D	Slave	V _{DDEH} =4.75–5.25 V	—	25	
			D		V _{DDEH} =3–3.6 V	—	25.7	
			D	Master (MTFE = 1, CPHA = 0)		—	21	
			D	Master (MTFE = 1, CPHA = 1)	V _{DDEH} =4.75–5.25 V	—	5	
			D		V _{DDEH} =3–3.6 V	—	6.3	
12	t _{HO}	CC	Data Hold Time for Outputs					
			D	Master (MTFE = 0)	V _{DDEH} =4.75–5.25 V	–5	—	ns
			D		V _{DDEH} =3–3.6 V	–6.3	—	
			D	Slave		5.5	—	
			D	Master (MTFE = 1, CPHA = 0)		3	—	
			D	Master (MTFE = 1, CPHA = 1)	V _{DDEH} =4.75–5.25 V	–5	—	
			D		V _{DDEH} =3–3.6 V	–6.3	—	

¹ All DSPI timing specifications use the fastest slew rate (SRC = 0b11) on pad type pad_msr. DSPI signals using pad type of pad_ssr have an additional delay based on the slew rate. DSPI timing is specified at V_{DDEH} = 3.0 to 3.6 V, T_A = T_L to T_H, and C_L = 50 pF with SRC = 0b11.

² Data is verified at f_{sys} = 102 MHz and 153 MHz (100 MHz and 150 MHz + 2% frequency modulation).

³ The minimum DSPI Cycle Time restricts the baud rate selection for given system clock rate. These numbers are calculated based on two MPC5642A devices communicating over a DSPI link.

⁴ The actual minimum SCK cycle time is limited by pad performance.

⁵ For DSPI channels using LVDS output operation, up to 40 MHz SCK cycle time is supported. For non-LVDS output, maximum SCK frequency is 20 MHz. Appropriate clock division must be applied.

⁶ The maximum value is programmable in DSPI_CTARx[PSSCK] and DSPI_CTARx[CSSCK].

Electrical characteristics

- ⁷ Timing met when PCSSCK = 3 (01), and CSSCK = 2 (0000)
- ⁸ The maximum value is programmable in DSPI_CTARx[PASC] and DSPI_CTARx[ASC].
- ⁹ Timing met when ASC = 2 (0000), and PASC = 3 (01)
- ¹⁰ Timing met when PCSSCK = 3
- ¹¹ Timing met when ASC = 3
- ¹² This number is calculated assuming the SMPL_PT bitfield in DSPI_MCR is set to 0b10.

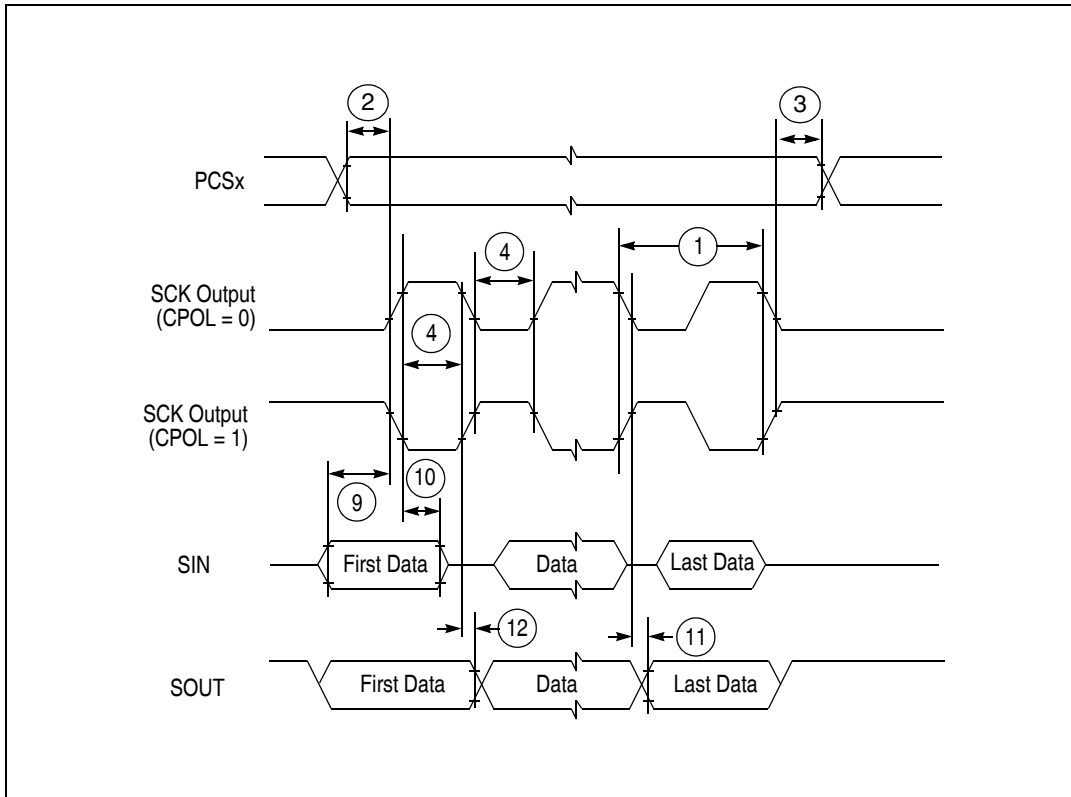

Figure 24. DSPI classic SPI timing (master, CPHA = 0)

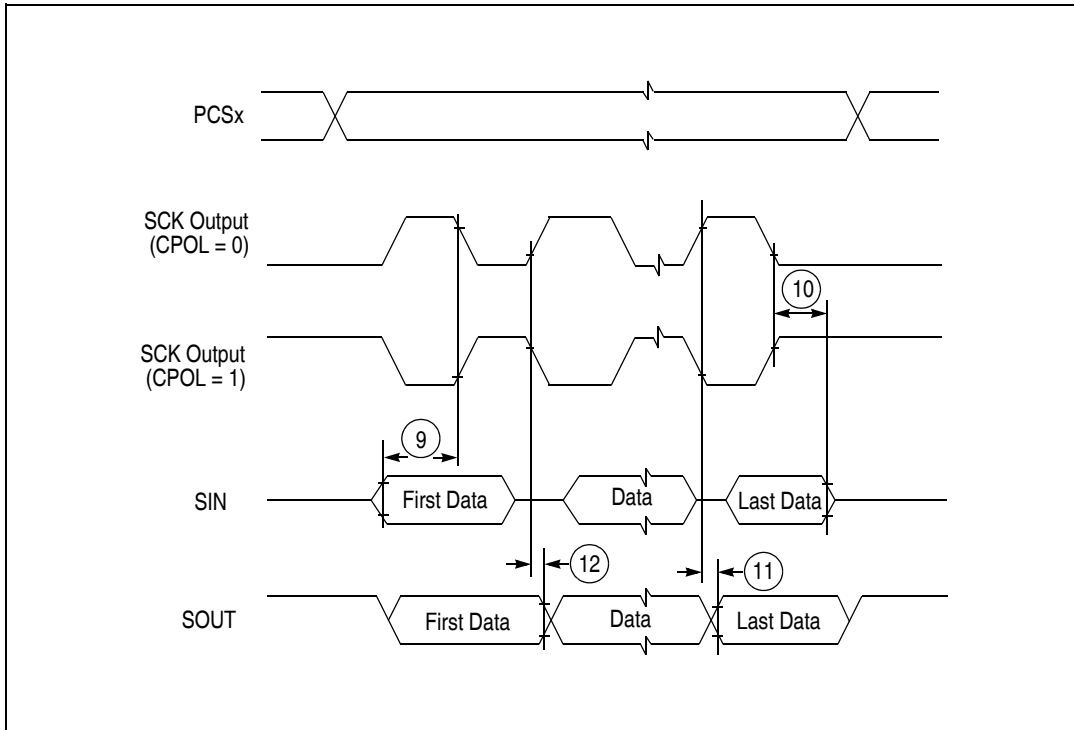

Figure 25. DSPI classic SPI timing (master, CPHA = 1)

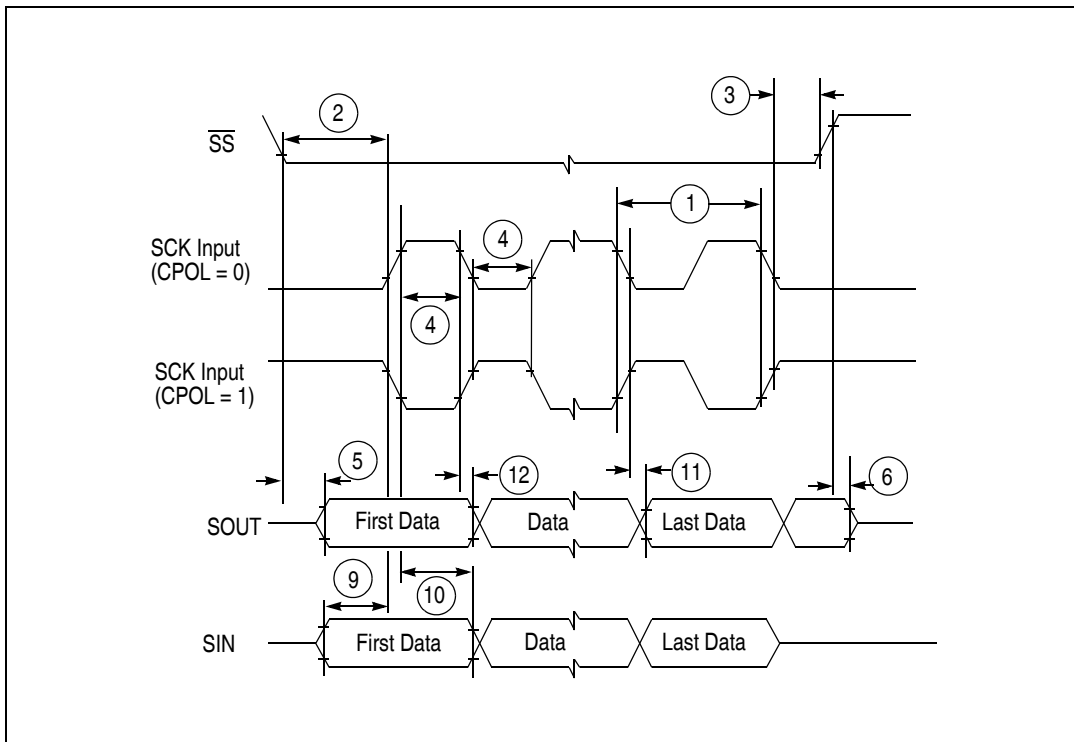

Figure 26. DSPI classic SPI timing (slave, CPHA = 0)

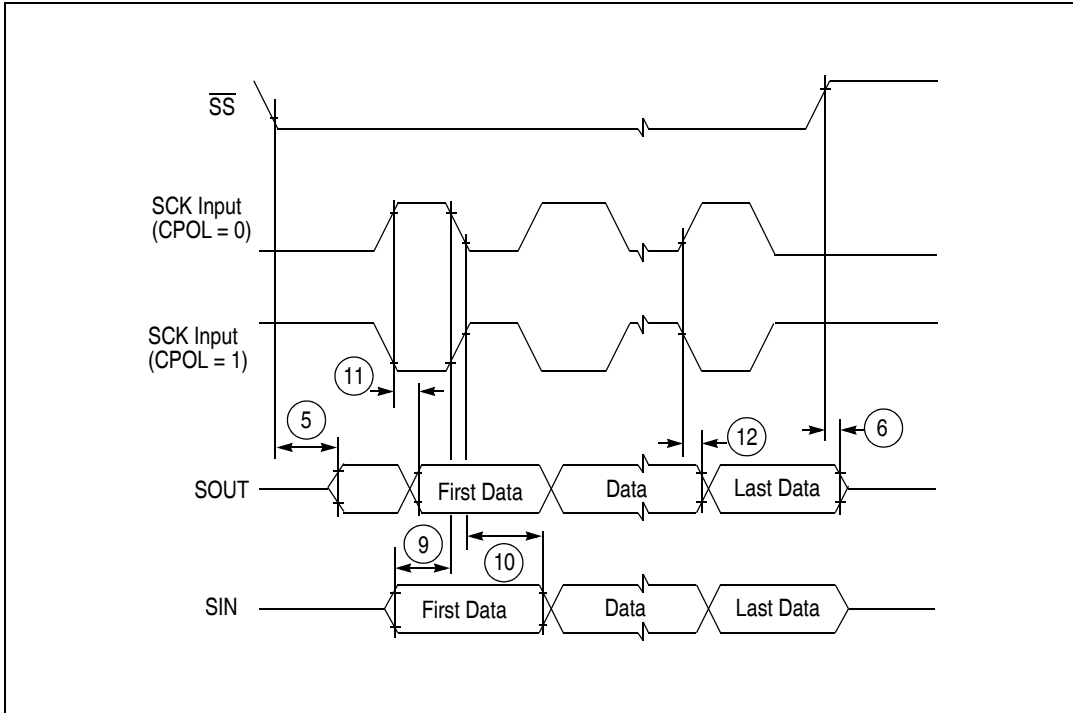

Figure 27. DSPI classic SPI timing (slave, CPHA = 1)

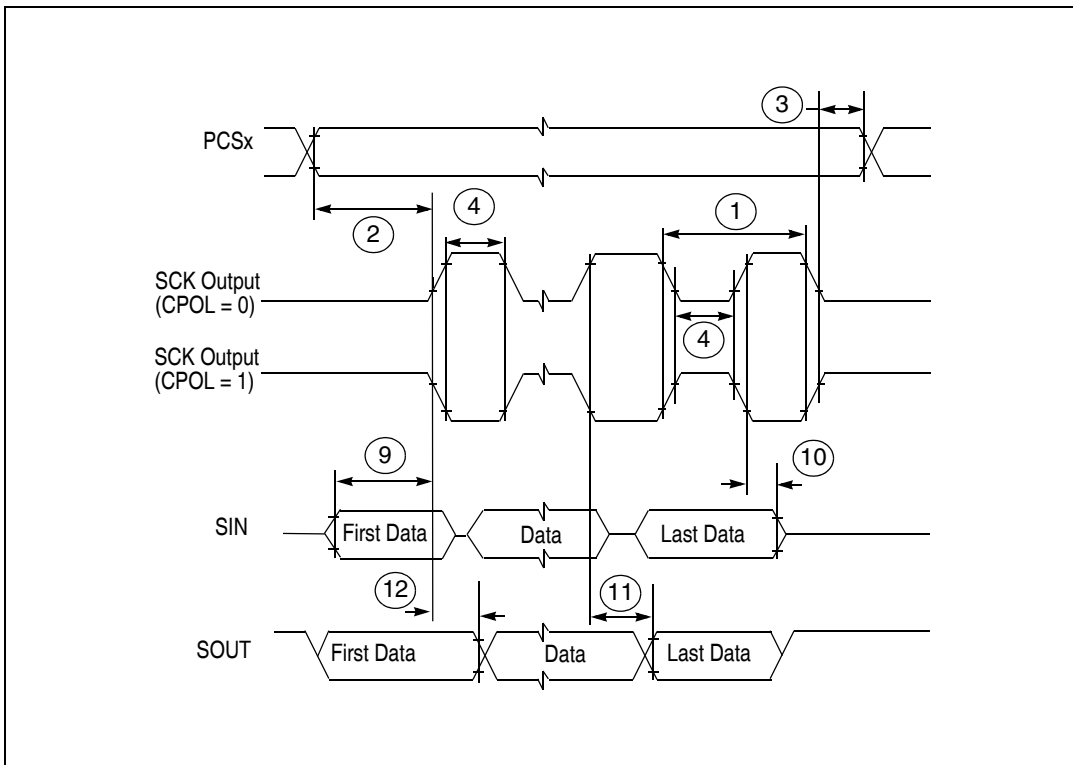

Figure 28. DSPI modified transfer format timing (master, CPHA = 0)

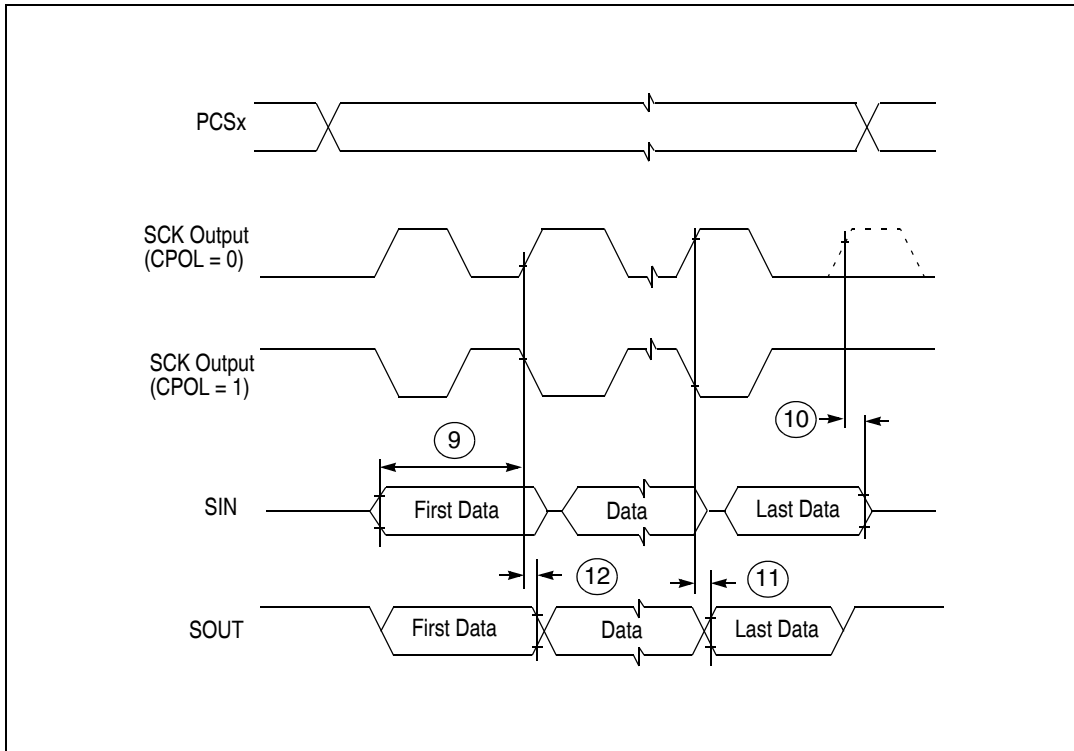

Figure 29. DSPI modified transfer format timing (master, CPHA = 1)

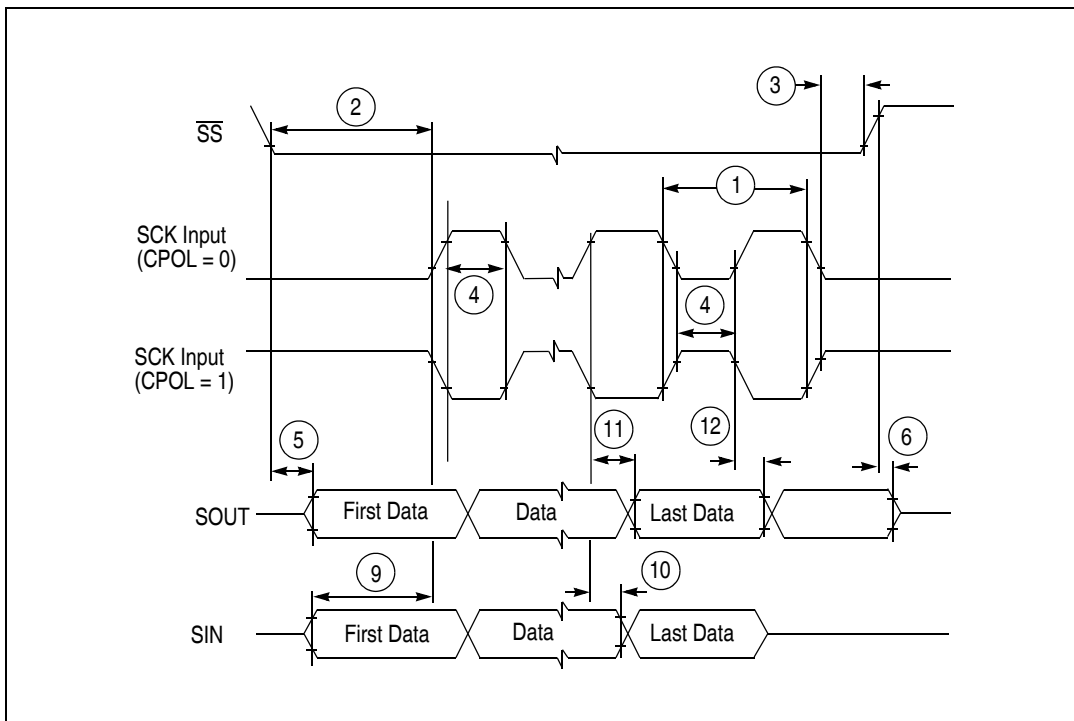

Figure 30. DSPI modified transfer format timing (slave, CPHA = 0)

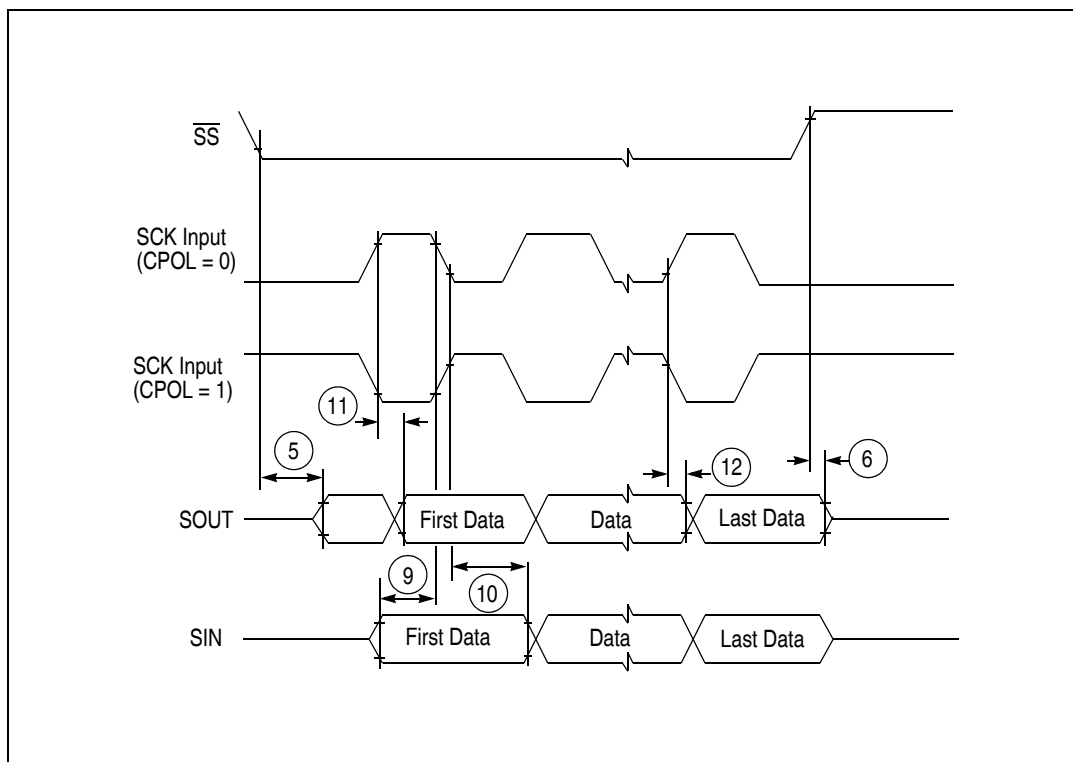

Figure 31. DSPI modified transfer format timing (slave, CPHA = 1)

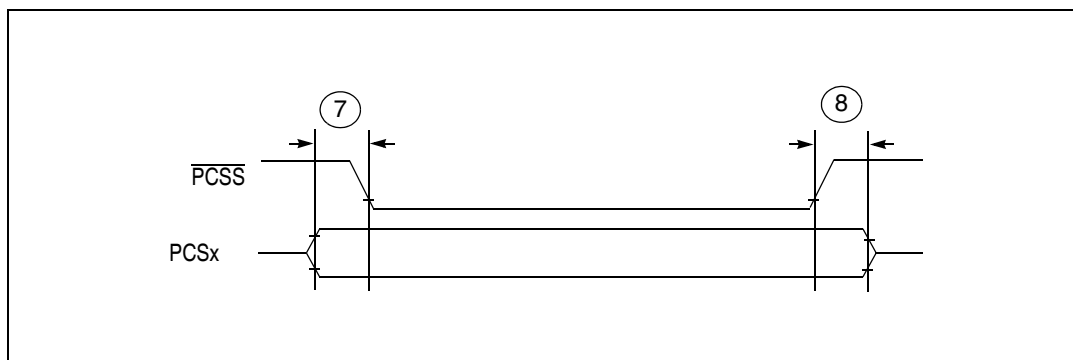

Figure 32. DSPI PCS strobe (\overline{PCSS}) timing

3.17.9 eQADC SSI timing

Table 47. eQADC SSI timing characteristics (pads at 3.3 V or at 5.0 V)¹

CLOAD = 25 pF on all outputs. Pad drive strength set to maximum.								
#	Symbol	C	Rating	Value			Unit	
				Min	Typ	Max		
1	f_{FCK}	CC	D	FCK Frequency ^{2,3}	1/17		1/2	$f_{\text{SYS_CLK}}$
1	t_{FCK}	CC	D	FCK Period ($t_{\text{FCK}} = 1/f_{\text{FCK}}$)	2		17	$t_{\text{SYS_CLK}}$
2	t_{FCKHT}	CC	D	Clock (FCK) High Time	$t_{\text{SYS_CLK}} - 6.5$		$9 * t_{\text{SYS_CLK}} + 6.5$	ns
3	t_{FCKLT}	CC	D	Clock (FCK) Low Time	$t_{\text{SYS_CLK}} - 6.5$		$8 * t_{\text{SYS_CLK}} + 6.5$	ns
4	$t_{\text{SDS_LL}}$	CC	D	SDS Lead/Lag Time	-7.5		7.5	ns
5	$t_{\text{SDO_LL}}$	CC	D	SDO Lead/Lag Time	-7.5		7.5	ns
6	t_{DVFE}	CC	D	Data Valid from FCK Falling Edge ($t_{\text{FCKLT}} + t_{\text{SDO_LL}}$)	1			ns
7	$t_{\text{EQ_SU}}$	CC	D	eQADC Data Setup Time (Inputs)	22			ns
8	$t_{\text{EQ_HO}}$	CC	D	eQADC Data Hold Time (Inputs)	1			ns

¹ SSI timing specified at $f_{\text{SYS}} = 80 \text{ MHz}$, $V_{\text{DD}} = 1.14 \text{ V}$ to 1.32 V , $V_{\text{DDEH}} = 4.75 \text{ V}$ to 5.25 V , $T_{\text{A}} = T_{\text{L}}$ to T_{H} , and $C_{\text{L}} = 50 \text{ pF}$ with $\text{SRC} = 0b00$.

² Maximum operating frequency is highly dependent on track delays, master pad delays, and slave pad delays.

³ FCK duty is not 50% when it is generated through the division of the system clock by an odd number.

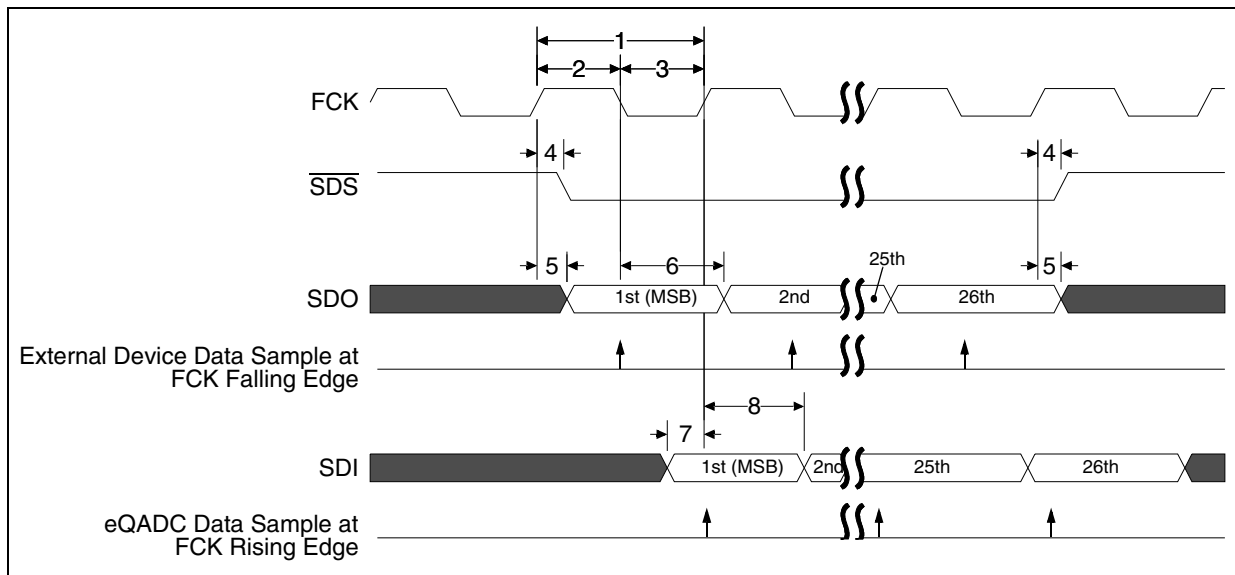

Figure 33. eQADC SSI timing

3.17.10 FlexCAN system clock source

Table 48. FlexCAN engine system clock divider threshold

#	Symbol	Characteristic	Value	Unit
1	f_{CAN_TH}	FlexCAN engine system clock threshold	100	MHz

Table 49. FlexCAN engine system clock divider

System frequency	Required SIU_SYSDIV[CAN_SRC] value
$\leq f_{CAN_TH}$	0 ^{1,2}
$> f_{CAN_TH}$	1 ^{2,3}

¹ Divides system clock source for FlexCAN engine by 1

² System clock is only selected for FlexCAN when CAN_CR[CLK_SRC] = 1

³ Divides system clock source for FlexCAN engine by 2

4 Packages

4.1 Package mechanical data

4.1.1 176 LQFP

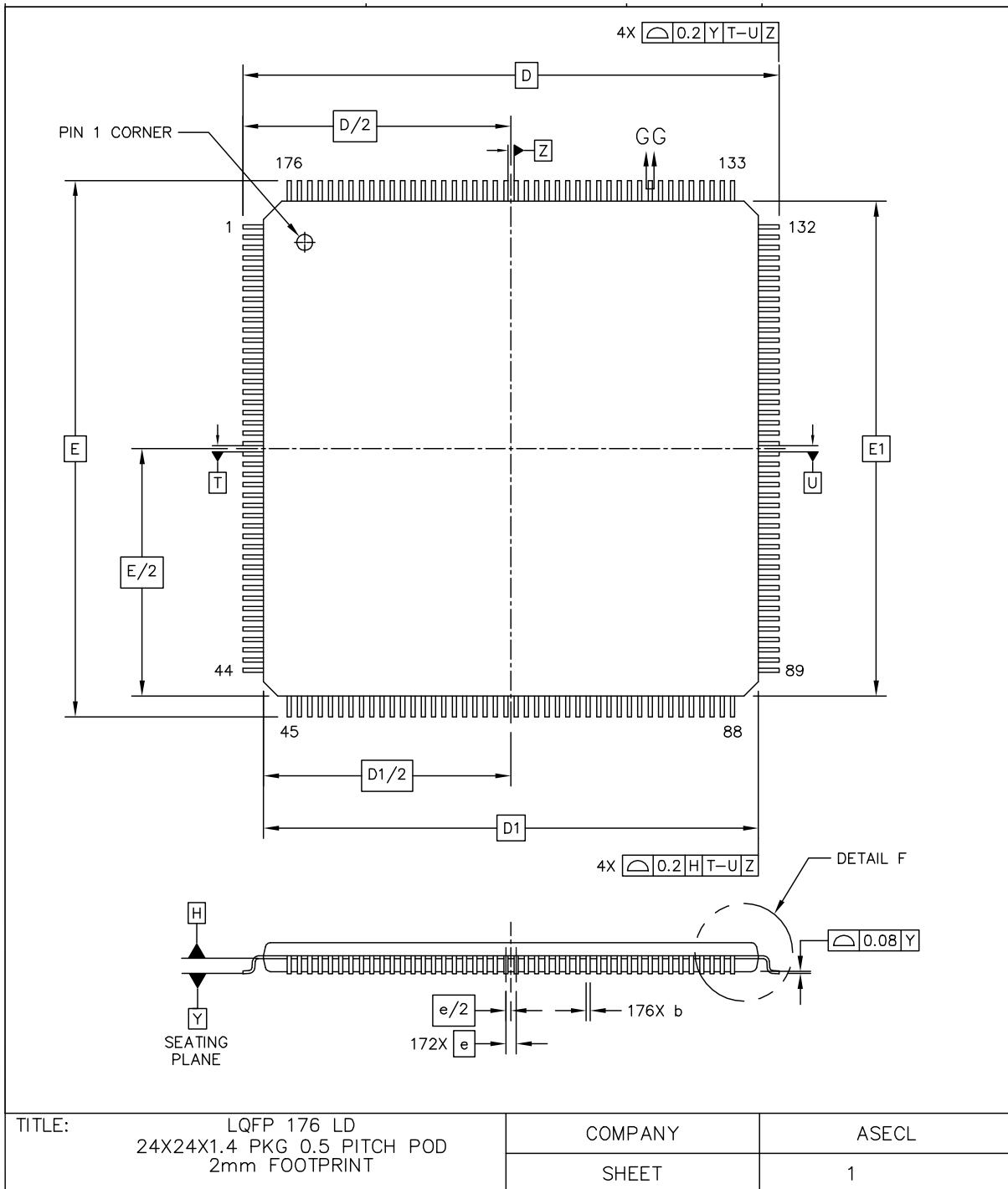

Figure 34. 176 LQFP package mechanical drawing (part 1)

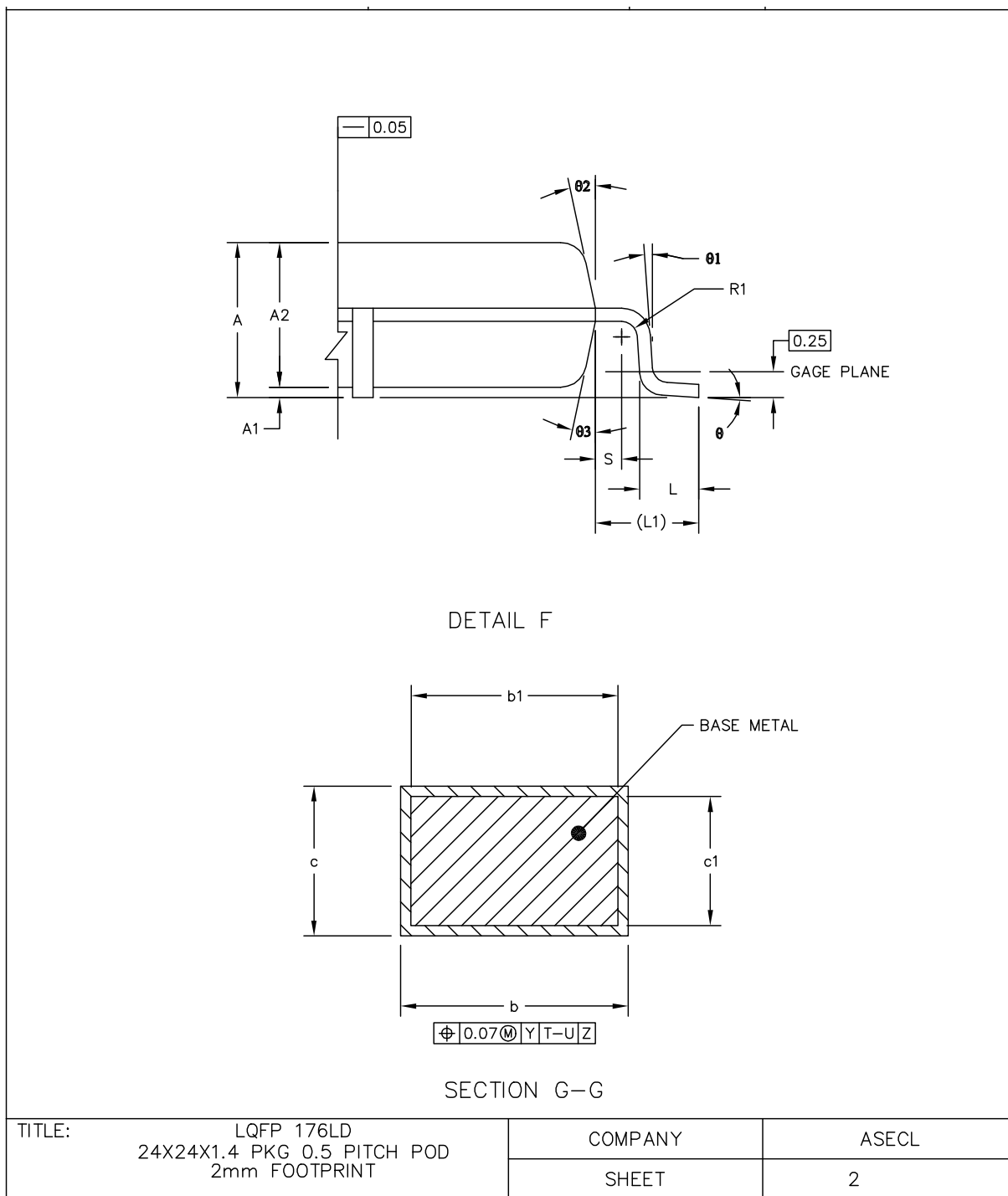

Figure 35. 176 LQFP package mechanical drawing (part 2)

NOTES:

1. DIMENSIONS D1 AND E1 DO NOT INCLUDE MOLD PROTRUSION. ALLOWABLE PROTRUSION IS 0.25MM PER SIDE. DIMENSIONS D1 AND E1 DO INCLUDE MOLD MISMATCH AND ARE DETERMINED AT DATUM PLANE DATUM H.
2. DIMENSION b DOES NOT INCLUDE DAMBAR PROTRUSION. DAMBAR PROTRUSION. ALLOWABLE DAMBAR PROTRUSION SHALL NOT CAUSE THE LEAD WIDTH TO EXCEED THE MAXIMUM b DIMENSION BY MORE THEN 0.08MM. DAMBAR CAN NOT BE LOCATED ON THE LOWER RADIUS OR THE FOOT. MINIMUM BETWEEN PROTRUSION AND AN ADJACENT LEAD IS 0.07MM FOR 0.4MM AND 0.5MM PITCH PACKAGES.

DIM	MIN	NOM	MAX	DIM	MIN	NOM	MAX	DIM	MIN	NOM	MAX
A	---		1.6	L1		1 REF					
A1	0.05		0.15	R1	0.08		---				
A2	1.35	1.4	1.45	R2	0.08		0.2				
b	0.17	0.22	0.27	S		0.2 REF					
b1	0.17	0.2	0.23	θ	0°	3.5°	7°				
c	0.09		0.2	$\theta 1$	0°		---				
c1	0.09		0.16	$\theta 2$	11°	12°	13°				
D		26 BSC		$\theta 3$	11°	12°	13°				
D1		24 BSC									
e		0.5 BSC									
E		26 BSC									
E1		24 BSC									
L	0.45	0.6	0.75								
				UNIT		DIMENSION AND TOLERANCES		REFERANCE DOCUMENT			
				MM		ASME Y14.5M		64-06-280-1392			
TITLE: LQFP 176LD 24X24X1.4 PKG 0.5 PITCH POD 2mm FOOTPRINT				COMPANY				ASECL			
				SHEET				3			

Figure 36. 176 LQFP package mechanical drawing (part 3)

4.1.2 208 MAPBGA

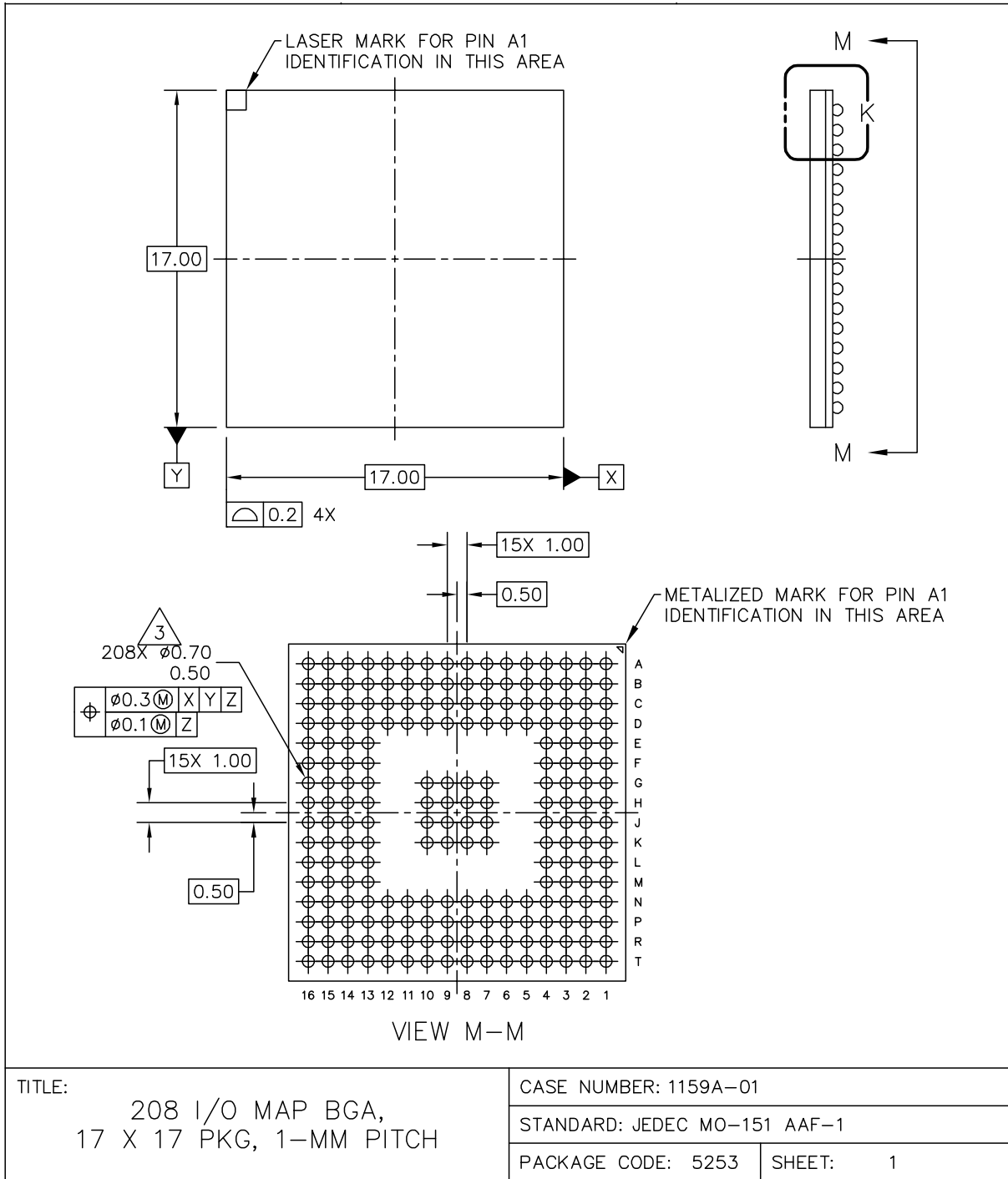
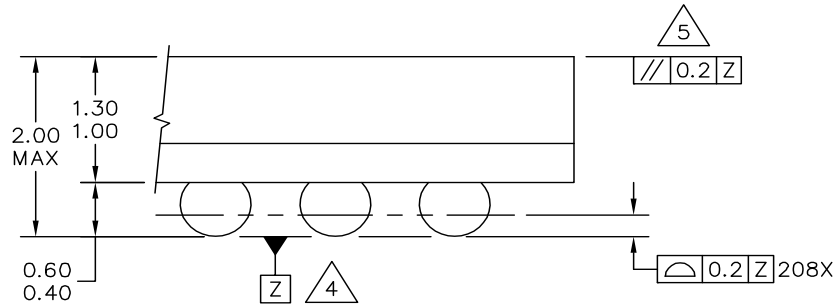

Figure 37. 208 MAPBGA package mechanical drawing (part 1)



DETAIL K
(ROTATED 90° CLOCKWISE)

NOTES:

1. ALL DIMENSIONS ARE IN MILLIMETERS.
2. INTERPRET DIMENSIONS AND TOLERANCES PER ASME Y14.5M-1994.
3. DIMENSION b IS MEASURED AT THE MAXIMUM SOLDER BALL DIAMETER, PARALLEL TO DATUM PLANE Z.
4. DATUM Z (SEATING PLANE) IS DEFINED BY THE SPHERICAL CROWNS OF THE SOLDER BALLS.
5. PARALLELISM MEASUREMENT SHALL EXCLUDE ANY EFFECT OF MARK ON TOP SURFACE OF PACKAGE.

TITLE: 208 I/O MAP BGA, 17 X 17 PKG, 1-MM PITCH	CASE NUMBER: 1159A-01	
	STANDARD: JEDEC MO-151 AAF-1	
	PACKAGE CODE: 5253	SHEET: 2

Figure 38. 208 MAPBGA package mechanical drawing (part 2)

4.1.3 324 TEPBGA

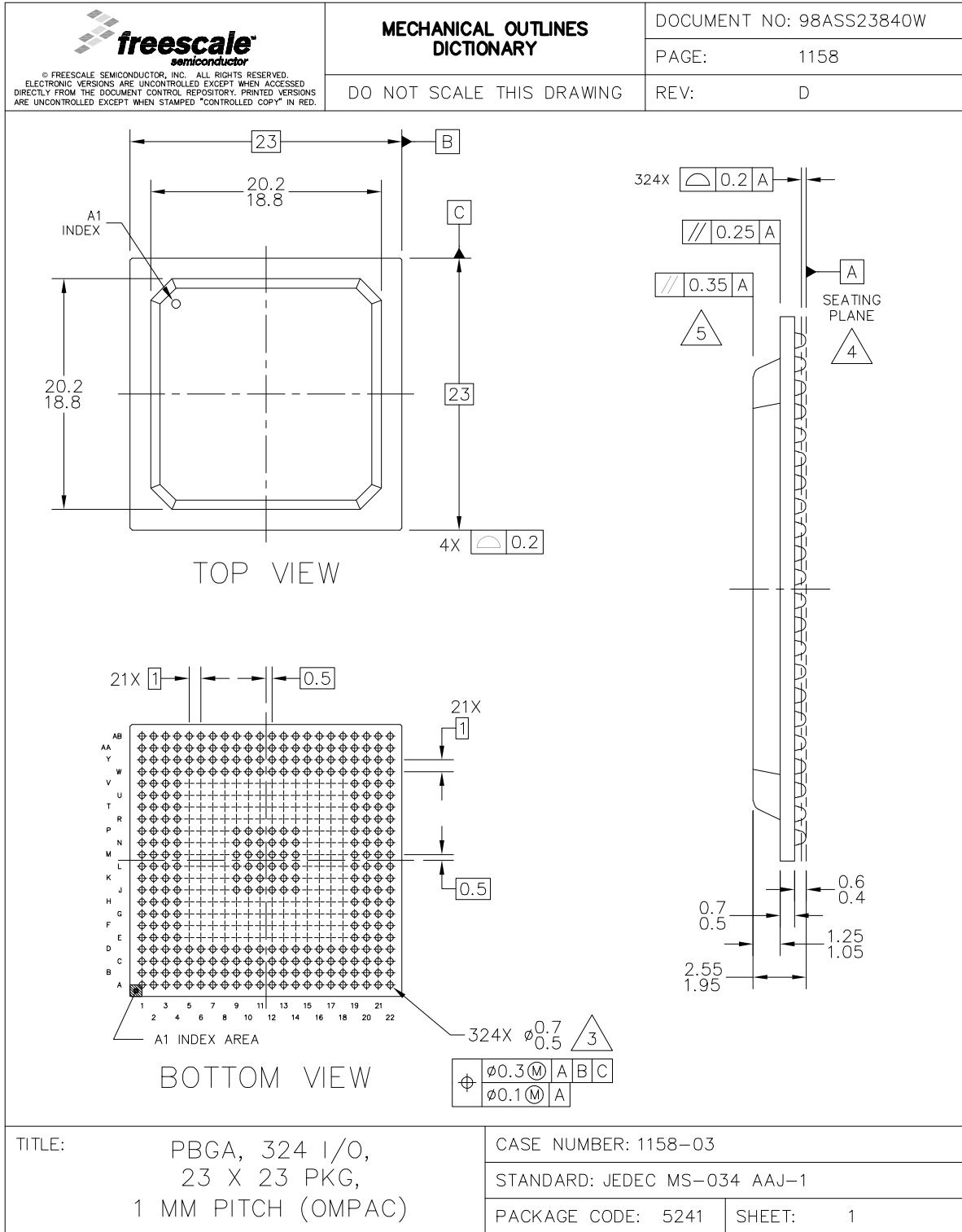

Figure 39. 324 BGA package mechanical drawing (part 1)

<p>© FREESCALE SEMICONDUCTOR, INC. ALL RIGHTS RESERVED. ELECTRONIC VERSIONS ARE UNCONTROLLED EXCEPT WHEN ACCESSED DIRECTLY FROM THE DOCUMENT CONTROL REPOSITORY. PRINTED VERSIONS ARE UNCONTROLLED EXCEPT WHEN STAMPED "CONTROLLED COPY" IN RED.</p>	MECHANICAL OUTLINES DICTIONARY	DOCUMENT NO: 98ASS23840W	
		PAGE:	1158
DO NOT SCALE THIS DRAWING		REV:	D
<p>NOTES:</p> <ol style="list-style-type: none"> 1. ALL DIMENSIONS IN MILLIMETERS. 2. DIMENSIONING AND TOLERANCING PER ASME Y14.5M-1994. 3. MAXIMUM SOLDER BALL DIAMETER MEASURED PARALLEL TO DATUM A. 4. DATUM A, THE SEATING PLANE, IS DETERMINED BY THE SPHERICAL CROWNS OF THE SOLDER BALLS. 5. PARALLELISM MEASUREMENT SHALL EXCLUDE ANY EFFECT OF MARK ON TOP SURFACE OF PACKAGE. 			
TITLE:	PBGA, 324 I/O, 23 X 23 PKG, 1 MM PITCH (OMPAC)	CASE NUMBER: 1158-03	
		STANDARD: JEDEC MS-034 AAJ-1	
		PACKAGE CODE: 5241	SHEET: 2

Figure 40. 324 BGA package mechanical drawing (part 2)

5 Ordering information

Table 50 shows the orderable part numbers for the MPC5642A series.

Table 50. Orderable part number summary

Part number	Flash/SRAM	Package	Speed (MHz)
SPC5642AF2MLU1	2 MB/128 KB	176 LQFP (Pb free)	150
SC667201MMG1	2 MB/128 KB	208 MAPBGA (Pb free)	
SPC5642AF2MVZ1	2 MB/128 KB	324 TEPBGA	
SPC5642AF2MLU2	2 MB/128 KB	176 LQFP (Pb free)	120
SC667201MMG2	2 MB/128 KB	208 MAPBGA (Pb free)	
SPC5642AF2MVZ2	2 MB/128 KB	324 TEPBGA	
SPC5642AF2MLU3	2 MB/128 KB	176 LQFP (Pb free)	80
SC667201MMG3	2 MB/128 KB	208 MAPBGA (Pb free)	
SPC5642AF2MVZ3	2 MB/128 KB	324 TEPBGA	

Figure 41. Product code structure

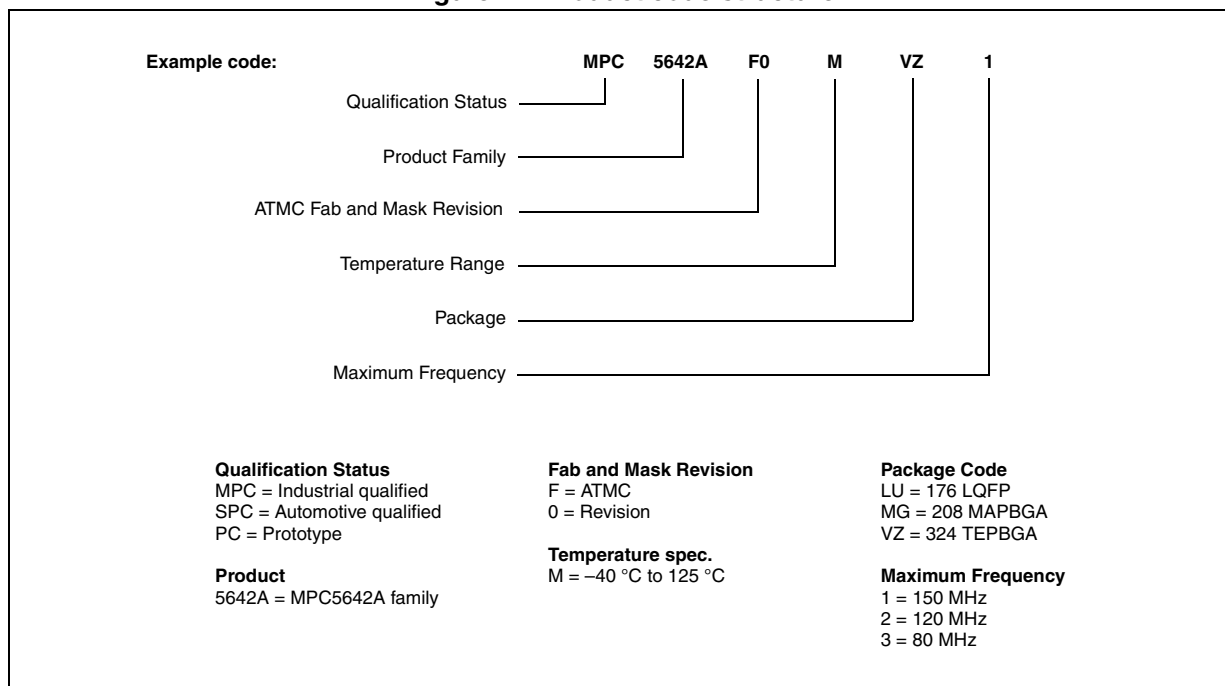

6 Document revision history

Table 51 summarizes customer facing revisions to this document.

Table 51. Revision history

Date	Revision	Substantive changes
05 Oct 2010	1	Initial release
26 Mar 2012	2	<p>Figure 1 (MPC5642A series block diagram), added ECSM block and its definition in the elegend.</p> <p>Table 2 (MPC5642A series block summary), added the following blocks: REACN, SIU, ECSM, FMPLL, PIT and SWT.</p> <p>Updated Table 8 (Absolute maximum ratings)</p> <p>In 3, Electrical characteristics, deleted the "Recommended operating conditions" subsection.</p> <p>Table 14 (PMC operating conditions and external regulators supply voltage), removed minimum value of V_{DDREG} and its footnote.</p> <p>Updated Table 15 (PMC electrical characteristics)</p> <p>Updated Section 3.6.1, Regulator example</p> <p>Updated Table 20 (DC electrical specifications)</p> <p>Figure 8 (Core voltage regulator controller external components preferred configuration), added "T1" label to indicate the transistor.</p> <p>Table 20 (DC electrical specifications), changed maximum value of V_{IL_LS} to 0.9, was 1.1</p> <p>Table 21 (I/O pad average I_{DDE} specifications), in the V_{DDE} column changed all 5.5 to 5.25</p> <p>Table 24 (DSPI LVDS pad specification):</p> <ul style="list-style-type: none"> Renamed V_{OC}, was V_{OD} Updated minimum and maximum value of V_{OC} deleted all footnote <p>Table 26 (Temperature sensor electrical characteristics), updated minimum and maximum value of accuracy</p> <p>Updated Section 3.12, eQADC electrical characteristics</p> <p>Added Section 3.13, Configuring SRAM wait states</p> <p>Updated Table 31 (APC, RWSC, WWSC settings vs. frequency of operation)</p> <p>Updated Table 32 (Flash program and erase specifications)</p> <p>Table 31 (APC, RWSC, WWSC settings vs. frequency of operation), changed all values in the WWSC column to 0b01.</p> <p>Updated Table 32 (Flash program and erase specifications)</p> <p>Table 33 (Flash EEPROM module life):</p> <ul style="list-style-type: none"> updated temperature value in the Retention description (was 150 °C, is 85 °C) added values for Retention <p>Table 34 (Pad AC specifications ($V_{DDE} = 4.75$ V)):</p> <ul style="list-style-type: none"> changed maximum value of Medium to 12/12 changed maximum value of Slow to 20/20 <p>Updated Table 35 (Pad AC specifications ($V_{DDE} = 3.0$ V))</p> <p>Table 37 (JTAG pin AC electrical characteristics):</p> <ul style="list-style-type: none"> changed all parameter classification to D changed minimum value of t_{TMSS}, t_{TDIS} to 10 <p>Updated Table 38 (Nexus debug port timing)</p> <p>Added Table 39 (Nexus debug port operating frequency)</p> <p>Table 39 (Nexus debug port operating frequency), added a footnote near the value of t_{AAI}</p> <p>Table 44 (eMIOS timing):</p> <ul style="list-style-type: none"> changed minimum value of t_{MOPW} to 1 removed the footnote of t_{MOPW}

Table 51. Revision history (continued)

Date	Revision	Substantive changes
26 Mar 2012	2 (cont'd)	Merged “DSPI timing ($V_{DDEH} = 3.0$ to 3.6 V)” and “DSPI timing ($V_{DDEH} = 4.5$ to 5.5 V)” tables into Table 46 (DSPI timing) and changed all parameter classification to D Table 47 (eQADC SSI timing characteristics (pads at 3.3 V or at 5.0 V)) changed all parameter classification to D
04 May 2012	3	<p>Minor editorial changes and improvements throughout.</p> <p>In Section 2.4, Signal summary, Table 3 (MPC5642A signal properties), updated the following properties for the Nexus pins:</p> <ul style="list-style-type: none"> • Added a footnote to the “Nexus” title for this pin group. • Added a footnote to the “Name” entry for $\overline{EVT\bar{O}}$. • Updated the “Status During reset” entry for $\overline{EVT\bar{O}}$. <p>In Section 3.2, Maximum ratings, Table 8 (Absolute maximum ratings), removed the “TBD - To be defined” footnote.</p> <p>In Section 3.6, Power management control (PMC) and power on reset (POR) electrical specifications, removed the “Voltage regulator controller (VRC) electrical specifications” subsection.</p> <p>In Section 3.8, DC electrical specifications, Table 20 (DC electrical specifications), removed the “TBD - To be defined” footnote.</p> <p>In Section 3.9, I/O pad current specifications, Table 21 (I/O pad average I_{DDE} specifications):</p> <ul style="list-style-type: none"> • Updated values and replaced TBDs with numerical data. • Removed the “TBD - To be defined” footnote. <p>In Section 3.9.1, I/O pad V_{RC33} current specifications, Table 22 (I/O pad V_{RC33} average I_{DDE} specifications):</p> <ul style="list-style-type: none"> • Updated values and replaced TBDs with numerical data. • Removed the “TBD - To be defined” footnote. <p>In Section 3.14, Platform flash controller electrical characteristics, Table 31 (APC, RWSC, WWSC settings vs. frequency of operation), removed the “TBD - To be defined” footnote.</p> <p>In Section 5, Ordering information, Table 50 (Orderable part number summary):</p> <ul style="list-style-type: none"> • Changed all part numbers from “MPC5642AF0...” to “SPC5642AF2...”. • Changed “MPC5642AF0MMG1” to “SC667201MMG1”. • Changed “MPC5642AF0MMG2” to “SC667201MMG2”. • Changed “MPC5642AF0MMG3” to “SC667201MMG3”. <p>In Table 51 (Revision history), removed several erroneous items from the Revision 2 entry.</p>
29 Jun 2012	3.1	<p>No content changes, technical or editorial, were made in this revision.</p> <p>Removed the “preliminary” footers throughout.</p> <p>Changed “Data Sheet: Advance Information” to “Data Sheet: Technical Data” on page 1.</p> <p>Removed the “product under development” disclaimer on page 1.</p>

How to Reach Us:

Home Page:

freescale.com

Web Support:

freescale.com/support

Information in this document is provided solely to enable system and software implementers to use Freescale products. There are no express or implied copyright licenses granted hereunder to design or fabricate any integrated circuits based on the information in this document.

Freescale reserves the right to make changes without further notice to any products herein. Freescale makes no warranty, representation, or guarantee regarding the suitability of its products for any particular purpose, nor does Freescale assume any liability arising out of the application or use of any product or circuit, and specifically disclaims any and all liability, including without limitation consequential or incidental damages. "Typical" parameters that may be provided in Freescale data sheets and/or specifications can and do vary in different applications, and actual performance may vary over time. All operating parameters, including "typicals," must be validated for each customer application by customer's technical experts. Freescale does not convey any license under its patent rights nor the rights of others. Freescale sells products pursuant to standard terms and conditions of sale, which can be found at the following address: <http://www.reg.net/v2/webservices/Freescale/Docs/TermsandConditions.htm>

Freescale, the Freescale logo, Altivec, C-5, CodeTest, CodeWarrior, ColdFire, C-Ware, Energy Efficient Solutions logo, Kinetis, mobileGT, PowerQUICC, Processor Expert, QorIQ, Qorivva, StarCore, Symphony, and VortiQa are trademarks of Freescale Semiconductor, Inc., Reg. U.S. Pat. & Tm. Off. Airfast, BeeKit, BeeStack, ColdFire+, CoreNet, Flexis, MagniV, MXC, Platform in a Package, QorIQ Qonverge, QUICC Engine, Ready Play, SafeAssure, SMARTMOS, TurboLink, Vybrid, and Xtrinsic are trademarks of Freescale Semiconductor, Inc. All other product or service names are the property of their respective owners. The Power Architecture and Power.org word marks and the Power and Power.org logos and related marks are trademarks and service marks licensed by Power.org.

© 2009, 2010, 2012 Freescale Semiconductor, Inc.

Document Number: MPC5642A

Rev. 3.1

06/2012



Looking for pricing, stock, or lifecycle information?

Click below to explore more details on WIN SOURCE:

 [View SPC5642AF2MLU1R on WIN SOURCE](#)

 [NXP / Nexperia Information](#)

Optimize Your Supply Chain with WIN SOURCE Solutions

-  Global Sourcing Solution
-  Obsolete Management
-  Cost Control Management
-  Shortage Management
-  Alternative Solution
-  Excess Inventory Management