



**THE DATASHEET OF
EFM8SB10F8A-A-QFN20**



EFM8 Sleepy Bee Family

EFM8SB1 Data Sheet



The EFM8SB1, part of the Sleepy Bee family of MCUs, is the world's most energy friendly 8-bit microcontrollers with a comprehensive feature set in small packages.

These devices offer lowest power consumption by combining innovative low energy techniques and short wakeup times from energy saving modes into small packages, making them well-suited for any battery operated applications. With an efficient 8051 core, 14 high-quality capacitive sense channels, and precision analog, the EFM8SB1 family is also optimal for embedded applications.

EFM8SB1 applications include the following:

- Touch pads / key pads
- Instrumentation panels
- Wearables
- Battery-operated consumer electronics

ENERGY FRIENDLY FEATURES

- Lowest MCU sleep current with supply brownout (50 nA)
- Lowest MCU active current (150 μ A / MHz at 24.5 MHz)
- Lowest MCU wake on touch average current (< 1 μ A)
- Lowest sleep current using internal RTC and supply brownout (< 300 nA)
- Ultra-fast wake up for digital and analog peripherals (< 2 μ s)
- Integrated LDO to maintain ultra-low active current at all voltages

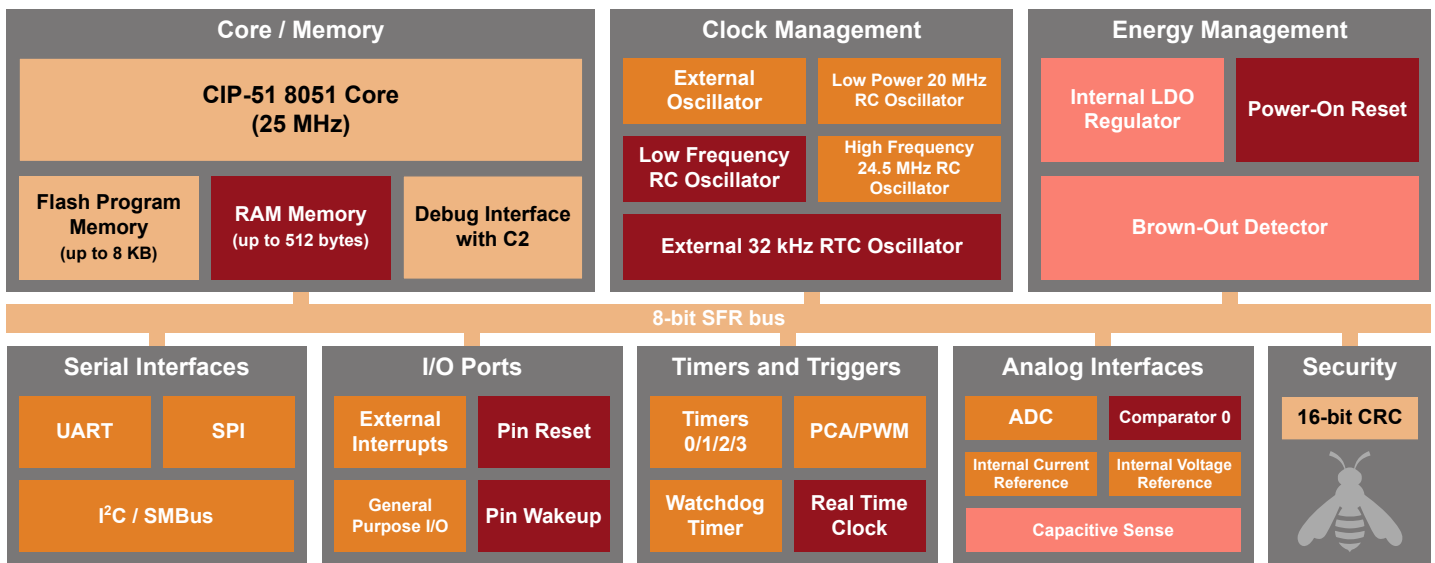

Lowest power mode with peripheral operational:

- Normal
- Idle
- Suspend
- Sleep

Table of Contents

1. Feature List	4
2. Ordering Information	5
3. System Overview	7
3.1 Introduction	7
3.2 Power	8
3.3 I/O	8
3.4 Clocking	9
3.5 Counters/Timers and PWM	9
3.6 Communications and Other Digital Peripherals	10
3.7 Analog	12
3.8 Reset Sources	13
3.9 Debugging	13
3.10 Bootloader	14
4. Electrical Specifications	16
4.1 Electrical Characteristics	16
4.1.1 Recommended Operating Conditions	16
4.1.2 Power Consumption	17
4.1.3 Reset and Supply Monitor	19
4.1.4 Flash Memory	20
4.1.5 Power Management Timing	20
4.1.6 Internal Oscillators	20
4.1.7 Crystal Oscillator	21
4.1.8 External Clock Input	21
4.1.9 ADC	22
4.1.10 Voltage Reference	23
4.1.11 Temperature Sensor	24
4.1.12 Comparators	25
4.1.13 Programmable Current Reference (IREF0)	26
4.1.14 Capacitive Sense (CS0)	27
4.1.15 Port I/O	28
4.1.16 SMBus	29
4.2 Thermal Conditions	31
4.3 Absolute Maximum Ratings	31
4.4 Typical Performance Curves	32
5. Typical Connection Diagrams	34
5.1 Power	34
5.2 Debug	34
5.3 Other Connections	35

- 6. Pin Definitions 36**
 - 6.1 EFM8SB1x-QFN20 Pin Definitions 37
 - 6.2 EFM8SB1x-QFN24 Pin Definitions 40
 - 6.3 EFM8SB1x-QSOP24 Pin Definitions. 43
 - 6.4 EFM8SB1x-CSP16 Pin Definitions 46
- 7. CSP16 Package Specifications 48**
 - 7.1 CSP16 Package Dimensions 48
 - 7.2 CSP16 PCB Land Pattern 50
 - 7.3 CSP16 Package Marking 51
- 8. QFN20G Package Specifications 52**
 - 8.1 QFN20 Package Dimensions 53
 - 8.2 QFN20 PCB Land Pattern 55
 - 8.3 QFN20 Package Marking 56
- 9. QFN20A Package Specifications 57**
 - 9.1 QFN20 Package Dimensions 58
 - 9.2 QFN20 PCB Land Pattern 60
 - 9.3 QFN20 Package Marking 61
- 10. QFN24 Package Specifications 62**
 - 10.1 QFN24 Package Dimensions. 62
 - 10.2 PCB Land Pattern 64
 - 10.3 Package Marking. 65
- 11. QSOP24 Package Specifications 66**
 - 11.1 Package Dimensions 66
 - 11.2 PCB Land Pattern 68
 - 11.3 Package Marking. 69
- 12. Revision History. 70**
 - 12.1 Revision 1.5 70
 - 12.2 Revision 1.4 70
 - 12.3 Revision 1.3 70
 - 12.4 Revision 1.2 70
 - 12.5 Revision 1.1 70

1. Feature List

The EFM8SB1 highlighted features are listed below.

- Core:
 - Pipelined CIP-51 Core
 - Fully compatible with standard 8051 instruction set
 - 70% of instructions execute in 1-2 clock cycles
 - 25 MHz maximum operating frequency
- Memory:
 - Up to 8 kB flash memory, in-system re-programmable from firmware.
 - Up to 512 bytes RAM (including 256 bytes standard 8051 RAM and 256 bytes on-chip XRAM)
- Power:
 - Internal LDO regulator for CPU core voltage
 - Power-on reset circuit and brownout detectors
- I/O: Up to 17 total multifunction I/O pins:
 - Flexible peripheral crossbar for peripheral routing
 - 5 mA source, 12.5 mA sink allows direct drive of LEDs
- Clock Sources:
 - Internal 20 MHz low power oscillator with $\pm 10\%$ accuracy
 - Internal 24.5 MHz precision oscillator with $\pm 2\%$ accuracy
 - Internal 16.4 kHz low-frequency oscillator or RTC 32 kHz crystal (RTC crystal not available on CSP16 packages)
 - External crystal, RC, C, and CMOS clock options
- Timers/Counters and PWM:
 - 32-bit Real Time Clock (RTC)
 - 3-channel Programmable Counter Array (PCA) supporting PWM, capture/compare, and frequency output modes with watchdog timer function
 - 4 x 16-bit general-purpose timers
- Communications and Digital Peripherals:
 - UART
 - SPI™ Master / Slave
 - SMBus™ / I2C™ Master / Slave
 - 16-bit CRC unit, supporting automatic CRC of flash at 256-byte boundaries
- Analog:
 - Capacitive Sense (CS0)
 - Programmable current reference (IREF0)
 - 12-Bit Analog-to-Digital Converter (ADC0)
 - 1 x Low-current analog comparator
- On-Chip, Non-Intrusive Debugging
 - Full memory and register inspection
 - Four hardware breakpoints, single-stepping
- Pre-loaded UART bootloader
- Temperature range -40 to 85 °C
- Single power supply 1.8 to 3.6 V
- QSOP24, QFN24, QFN20, and CSP16 packages

With on-chip power-on reset, voltage supply monitor, watchdog timer, and clock oscillator, the EFM8SB1 devices are truly standalone system-on-a-chip solutions. The flash memory is reprogrammable in-circuit, providing non-volatile data storage and allowing field upgrades of the firmware. The on-chip debugging interface (C2) allows non-intrusive (uses no on-chip resources), full speed, in-circuit debugging using the production MCU installed in the final application. This debug logic supports inspection and modification of memory and registers, setting breakpoints, single stepping, and run and halt commands. All analog and digital peripherals are fully functional while debugging. Each device is specified for 1.8 to 3.6 V operation. Devices are AEC-Q100 qualified (Grade 3). The G-grade devices are available in 16-pin CSP, 20-pin QFN, 24-pin QFN, or 24-pin QSOP packages, and A-grade devices are available in 20-pin QFN or 24-pin QFN packages. All package options are lead-free and RoHS compliant.

Note: CSP devices can be handled and soldered using industry standard surface mount assembly techniques. However, because CSP devices are essentially a piece of silicon and are not encapsulated in plastic, they are susceptible to mechanical damage and may be sensitive to light. When CSP packages must be used in an environment exposed to light, it may be necessary to cover the top and sides with an opaque material.

2. Ordering Information

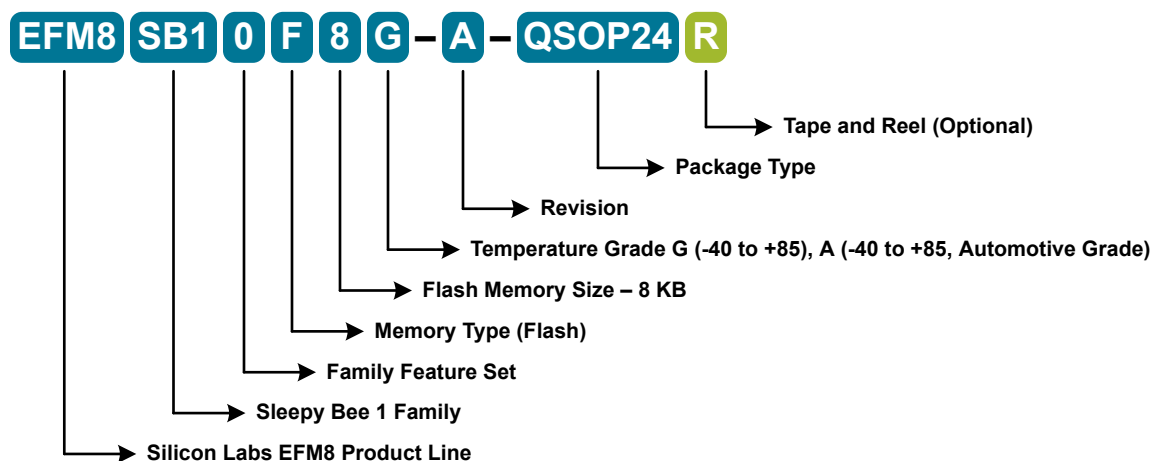

Figure 2.1. EFM8SB1 Part Numbering

All EFM8SB1 family members have the following features:

- CIP-51 Core running up to 25 MHz
- Three Internal Oscillators (24.5 MHz, 20 MHz, and 16 kHz)
- SMBus / I2C
- SPI
- UART
- 3-Channel Programmable Counter Array (PWM, Clock Generation, Capture/Compare)
- 4 16-bit Timers
- Analog Comparator
- 6-bit current source reference
- 12-bit Analog-to-Digital Converter with integrated multiplexer, voltage reference, and temperature sensor
- 16-bit CRC Unit
- AEC-Q100 qualified (Grade 3)
- Pre-loaded UART bootloader

In addition to these features, each part number in the EFM8SB1 family has a set of features that vary across the product line. The product selection guide shows the features available on each family member.

Table 2.1. Product Selection Guide

Ordering Part Number	Flash Memory (kB)	RAM (Bytes)	Digital Port I/Os (Total)	ADC0 Channels	Capacitive Touch Inputs	Pb-free (RoHS Compliant)	Temperature Range	Package
EFM8SB10F8G-A-QSOP24 ¹	8	512	17	10	14	Yes	-40 to +85 C	QSOP24
EFM8SB10F8G-A-QFN24	8	512	17	10	14	Yes	-40 to +85 C	QFN24
EFM8SB10F8G-A-QFN20	8	512	16	9	13	Yes	-40 to +85 C	QFN20G
EFM8SB10F8G-A-CSP16	8	512	13	9	12	Yes	-40 to +85 C	CSP16
EFM8SB10F4G-A-QFN20	4	512	16	9	13	Yes	-40 to +85 C	QFN20G

Ordering Part Number	Flash Memory (kB)	RAM (Bytes)	Digital Port I/Os (Total)	ADC0 Channels	Capacitive Touch Inputs	Pb-free (RoHS Compliant)	Temperature Range	Package
EFM8SB10F2G-A-QFN20	2	256	16	9	13	Yes	-40 to +85 C	QFN20G
EFM8SB10F8A-A-QFN24	8	512	17	10	14	Yes	-40 to +85 C	QFN24
EFM8SB10F8A-A-QFN20	8	512	16	9	13	Yes	-40 to +85 C	QFN20A
Note: 1. End of life.								

The A-grade (i.e. EFM8SB10F8A-A-QFN20) devices receive full automotive quality production status, including AEC-Q100 qualification, registration with International Material Data System (IMDS), and Part Production Approval Process (PPAP) documentation. PPAP documentation is available at www.silabs.com with a registered and NDA approved user account.

3. System Overview

3.1 Introduction

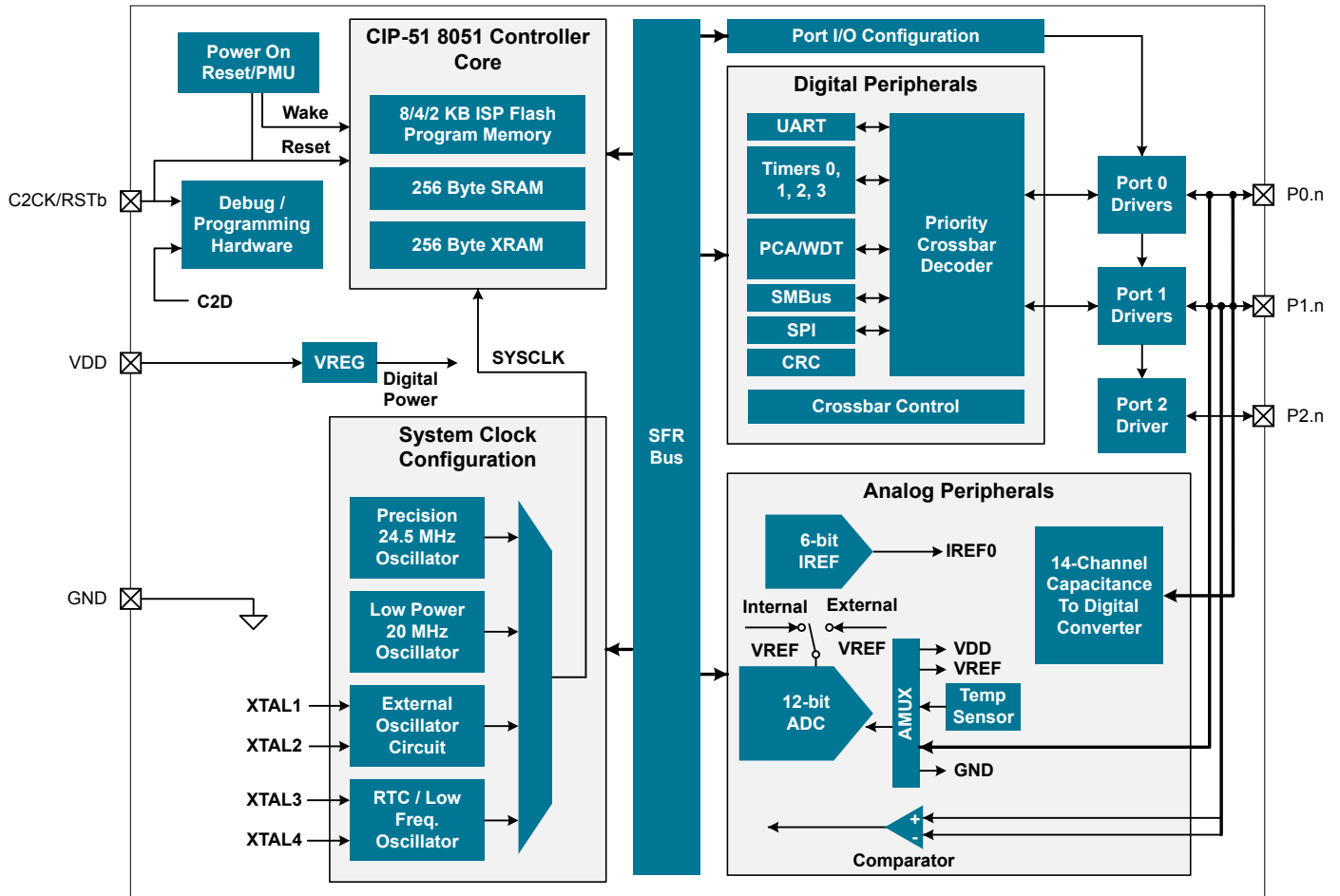

Figure 3.1. Detailed EFM8SB1 Block Diagram

This section describes the EFM8SB1 family at a high level. For more information on each module including register definitions, see the EFM8SB1 Reference Manual.

3.2 Power

All internal circuitry draws power from the VDD supply pin. External I/O pins are powered from the VIO supply voltage (or VDD on devices without a separate VIO connection), while most of the internal circuitry is supplied by an on-chip LDO regulator. Control over the device power can be achieved by enabling/disabling individual peripherals as needed. Each analog peripheral can be disabled when not in use and placed in low power mode. Digital peripherals, such as timers and serial buses, have their clocks gated off and draw little power when they are not in use.

Table 3.1. Power Modes

Power Mode	Details	Mode Entry	Wake-Up Sources
Normal	Core and all peripherals clocked and fully operational	—	—
Idle	<ul style="list-style-type: none"> Core halted All peripherals clocked and fully operational Code resumes execution on wake event 	Set IDLE bit in PCON0	Any interrupt
Suspend	<ul style="list-style-type: none"> Core and digital peripherals halted Internal oscillators disabled Code resumes execution on wake event 	<ol style="list-style-type: none"> Switch SYSCLK to HFOSC0 or LPOSC0 Set SUSPEND bit in PMU0CF 	<ul style="list-style-type: none"> RTC0 Alarm Event RTC0 Fail Event CS0 Interrupt Port Match Event Comparator 0 Rising Edge
Stop	<ul style="list-style-type: none"> All internal power nets shut down Pins retain state Exit on any reset source 	Set STOP bit in PCON0	Any reset source
Sleep ¹	<ul style="list-style-type: none"> Most internal power nets shut down Select circuits remain powered Pins retain state All RAM and SFRs retain state Code resumes execution on wake event 	<ol style="list-style-type: none"> Disable unused analog peripherals Set SLEEP bit in PMU0CF 	<ul style="list-style-type: none"> RTC0 Alarm Event RTC0 Fail Event Port Match Event Comparator 0 Rising Edge

Note:

- Entering Sleep may disconnect the active debug session.

3.3 I/O

Digital and analog resources are externally available on the device's multi-purpose I/O pins. Port pins P0.0-P1.7 can be defined as general-purpose I/O (GPIO), assigned to one of the internal digital resources through the crossbar or dedicated channels, or assigned to an analog function. Port pin P2.7 can be used as GPIO. Additionally, the C2 Interface Data signal (C2D) is shared with P2.7.

- Up to 17 multi-functions I/O pins, supporting digital and analog functions.
- Flexible priority crossbar decoder for digital peripheral assignment.
- Two drive strength settings for each pin.
- Two direct-pin interrupt sources with dedicated interrupt vectors (INT0 and INT1).
- Up to 16 direct-pin interrupt sources with shared interrupt vector (Port Match).

3.4 Clocking

The CPU core and peripheral subsystem may be clocked by both internal and external oscillator resources. By default, the system clock comes up running from the 20 MHz low power oscillator divided by 8.

- Provides clock to core and peripherals.
- 20 MHz low power oscillator (LPOSC0), accurate to $\pm 10\%$ over supply and temperature corners.
- 24.5 MHz internal oscillator (HFOSC0), accurate to $\pm 2\%$ over supply and temperature corners.
- 16.4 kHz low-frequency oscillator (LFOSC0) or external RTC 32 kHz crystal.
- External RC, C, CMOS, and high-frequency crystal clock options (EXTCLK).
- Clock divider with eight settings for flexible clock scaling: Divide the selected clock source by 1, 2, 4, 8, 16, 32, 64, or 128.

3.5 Counters/Timers and PWM

Real Time Clock (RTC0)

The RTC is an ultra low power, 36 hour 32-bit independent time-keeping Real Time Clock with alarm. The RTC has a dedicated 32 kHz oscillator. No external resistor or loading capacitors are required, and a missing clock detector features alerts the system if the external crystal fails. The on-chip loading capacitors are programmable to 16 discrete levels allowing compatibility with a wide range of crystals.

The RTC module includes the following features:

- Up to 36 hours (32-bit) of independent time keeping.
- Support for internal 16.4 kHz low frequency oscillator (LFOSC0) or external 32 kHz crystal (crystal not available on CSP16 packages).
- Internal crystal loading capacitors with 16 levels.
- Operation in the lowest power mode and across the full supported voltage range.
- Alarm and oscillator failure events to wake from the lowest power mode or reset the device.
- Buffered clock output available for other system devices even in the lowest power mode.

Programmable Counter Array (PCA0)

The programmable counter array (PCA) provides multiple channels of enhanced timer and PWM functionality while requiring less CPU intervention than standard counter/timers. The PCA consists of a dedicated 16-bit counter/timer and one 16-bit capture/compare module for each channel. The counter/timer is driven by a programmable timebase that has flexible external and internal clocking options. Each capture/compare module may be configured to operate independently in one of five modes: Edge-Triggered Capture, Software Timer, High-Speed Output, Frequency Output, or Pulse-Width Modulated (PWM) Output. Each capture/compare module has its own associated I/O line (CEXn) which is routed through the crossbar to port I/O when enabled.

- 16-bit time base.
- Programmable clock divisor and clock source selection.
- Up to three independently-configurable channels
- 8, 9, 10, 11 and 16-bit PWM modes (edge-aligned operation).
- Frequency output mode.
- Capture on rising, falling or any edge.
- Compare function for arbitrary waveform generation.
- Software timer (internal compare) mode.
- Integrated watchdog timer.

Timers (Timer 0, Timer 1, Timer 2, and Timer 3)

Several counter/timers are included in the device: two are 16-bit counter/timers compatible with those found in the standard 8051, and the rest are 16-bit auto-reload timers for timing peripherals or for general purpose use. These timers can be used to measure time intervals, count external events and generate periodic interrupt requests. Timer 0 and Timer 1 are nearly identical and have four primary modes of operation. The other timers offer both 16-bit and split 8-bit timer functionality with auto-reload and capture capabilities.

Timer 0 and Timer 1 include the following features:

- Standard 8051 timers, supporting backwards-compatibility with firmware and hardware.
- Clock sources include SYSCLK, SYSCLK divided by 12, 4, or 48, the External Clock divided by 8, or an external pin.
- 8-bit auto-reload counter/timer mode
- 13-bit counter/timer mode
- 16-bit counter/timer mode
- Dual 8-bit counter/timer mode (Timer 0)

Timer 2 and Timer 3 are 16-bit timers including the following features:

- Clock sources include SYSCLK, SYSCLK divided by 12, or the External Clock divided by 8.
- 16-bit auto-reload timer mode
- Dual 8-bit auto-reload timer mode
- Comparator 0 or RTC0 capture (Timer 2)
- RTC0 or EXTCLK/8 capture (Timer 3)

Watchdog Timer (WDT0)

The device includes a programmable watchdog timer (WDT) integrated within the PCA0 peripheral. A WDT overflow forces the MCU into the reset state. To prevent the reset, the WDT must be restarted by application software before overflow. If the system experiences a software or hardware malfunction preventing the software from restarting the WDT, the WDT overflows and causes a reset. Following a reset, the WDT is automatically enabled and running with the default maximum time interval. If needed, the WDT can be disabled by system software. The state of the RSTb pin is unaffected by this reset.

The Watchdog Timer integrated in the PCA0 peripheral has the following features:

- Programmable timeout interval
- Runs from the selected PCA clock source
- Automatically enabled after any system reset

3.6 Communications and Other Digital Peripherals

Universal Asynchronous Receiver/Transmitter (UART0)

UART0 is an asynchronous, full duplex serial port offering modes 1 and 3 of the standard 8051 UART. Enhanced baud rate support allows a wide range of clock sources to generate standard baud rates. Received data buffering allows UART0 to start reception of a second incoming data byte before software has finished reading the previous data byte.

The UART module provides the following features:

- Asynchronous transmissions and receptions.
- Baud rates up to $\text{SYSCLK}/2$ (transmit) or $\text{SYSCLK}/8$ (receive).
- 8- or 9-bit data.
- Automatic start and stop generation.
- Single-byte FIFO on transmit and receive.

Serial Peripheral Interface (SPI0)

The serial peripheral interface (SPI) module provides access to a flexible, full-duplex synchronous serial bus. The SPI can operate as a main (clock driver) or secondary (clock receiver) interface in both 3-wire or 4-wire modes, and supports multiple main/secondary devices on a single SPI bus. The chip-select (NSS) signal can be configured as an input to select the SPI in secondary mode, or to disable main mode operation in an environment with multiple main interfaces, avoiding contention on the SPI bus when more than one main device attempts simultaneous data transfers. NSS can also be configured as a firmware-controlled chip-select output in main interface mode, or disabled to reduce the number of pins required. Additional general purpose port I/O pins can be used to select multiple secondary devices.

The SPI module includes the following features:

- Supports 3- or 4-wire operation in master or slave modes.
- Supports external clock frequencies up to $\text{SYSCLK} / 2$ in master mode and $\text{SYSCLK} / 10$ in slave mode.
- Support for four clock phase and polarity options.
- 8-bit dedicated clock rate generator.
- Support for multiple masters on the same data lines.

System Management Bus / I2C (SMB0)

The SMBus I/O interface is a two-wire, bi-directional serial bus. The SMBus is compliant with the System Management Bus Specification, version 1.1, and compatible with the I²C serial bus.

The SMBus module includes the following features:

- Standard (up to 100 kbps) and Fast (400 kbps) transfer speeds.
- Support for leader, follower, and multi-leader modes.
- Hardware synchronization and arbitration for multi-leader mode.
- Clock low extending (clock stretching) to interface with faster leaders.
- Hardware support for 7-bit follower and general call address recognition.
- Firmware support for 10-bit follower address decoding.
- Ability to inhibit all follower states.
- Programmable data setup/hold times.

16-bit CRC (CRC0)

The cyclic redundancy check (CRC) module performs a CRC using a 16-bit polynomial. CRC0 accepts a stream of 8-bit data and posts the 16-bit result to an internal register. In addition to using the CRC block for data manipulation, hardware can automatically CRC the flash contents of the device.

The CRC module is designed to provide hardware calculations for flash memory verification and communications protocols. The CRC module supports the standard CCITT-16 16-bit polynomial (0x1021), and includes the following features:

- Support for CCITT-16 polynomial
- Byte-level bit reversal
- Automatic CRC of flash contents on one or more 256-byte blocks
- Initial seed selection of 0x0000 or 0xFFFF

3.7 Analog

Capacitive Sense (CS0)

The Capacitive Sense subsystem uses a capacitance-to-digital circuit to determine the capacitance on a port pin. The module can take measurements from different port pins using the module's analog multiplexer. The module can be configured to take measurements on one port pin, a group of port pins one-by-one using auto-scan, or the total capacitance on multiple channels together. A selectable gain circuit allows the designer to adjust the maximum allowable capacitance. An accumulator is also included, which can be configured to average multiple conversions on an input channel. Interrupts can be generated when the CS0 peripheral completes a conversion or when the measured value crosses a configurable threshold.

The Capacitive Sense module includes the following features:

- Measure multiple pins one-by-one using auto-scan or total capacitance on multiple channels together.
- Configurable input gain.
- Hardware auto-accumulate and average.
- Multiple internal start-of-conversion sources.
- Operational in Suspend when all other clocks are disabled.
- Interrupts available at the end of a conversion or when the measured value crosses a configurable threshold.

Programmable Current Reference (IREF0)

The programmable current reference (IREF0) module enables current source or sink with two output current settings: Low Power Mode and High Current Mode. The maximum current output in Low Power Mode is 63 μA (1 μA steps) and the maximum current output in High Current Mode is 504 μA (8 μA steps).

The IREF module includes the following features:

- Capable of sourcing or sinking current in programmable steps.
- Two operational modes: Low Power Mode and High Current Mode.
- Fine-tuning mode for higher output precision available in conjunction with the PCA0 module.

12-Bit Analog-to-Digital Converter (ADC0)

The ADC is a successive-approximation-register (SAR) ADC with 12-, 10-, and 8-bit modes, integrated track-and hold and a programmable window detector. The ADC is fully configurable under software control via several registers. The ADC may be configured to measure different signals using the analog multiplexer. The voltage reference for the ADC is selectable between internal and external reference sources.

- Up to 10 external inputs.
- Single-ended 12-bit and 10-bit modes.
- Supports an output update rate of 75 ksp/s samples per second in 12-bit mode or 300 ksp/s samples per second in 10-bit mode.
- Operation in low power modes at lower conversion speeds.
- Asynchronous hardware conversion trigger, selectable between software, external I/O and internal timer sources.
- Output data window comparator allows automatic range checking.
- Support for burst mode, which produces one set of accumulated data per conversion-start trigger with programmable power-on settling and tracking time.
- Conversion complete and window compare interrupts supported.
- Flexible output data formatting.
- Includes an internal 1.65 V fast-settling reference and support for external reference.
- Integrated temperature sensor.

Low Current Comparator (CMP0)

An analog comparator is used to compare the voltage of two analog inputs, with a digital output indicating which input voltage is higher. External input connections to device I/O pins and internal connections are available through separate multiplexers on the positive and negative inputs. Hysteresis, response time, and current consumption may be programmed to suit the specific needs of the application.

The comparator module includes the following features:

- Input options in addition to the pins:
 - Capacitive Sense Comparator output.
 - VDD.
 - VDD divided by 2.
 - Internal connection to LDO output.
 - Direct connection to GND.
- Synchronous and asynchronous outputs can be routed to pins via crossbar.
- Programmable hysteresis between 0 and ± 20 mV.
- Programmable response time.
- Interrupts generated on rising, falling, or both edges.

3.8 Reset Sources

Reset circuitry allows the controller to be easily placed in a predefined default condition. On entry to this reset state, the following occur:

- The core halts program execution.
- Module registers are initialized to their defined reset values unless the bits reset only with a power-on reset.
- External port pins are forced to a known state.
- Interrupts and timers are disabled.

All registers are reset to the predefined values noted in the register descriptions unless the bits only reset with a power-on reset. The contents of RAM are unaffected during a reset; any previously stored data is preserved as long as power is not lost. The Port I/O latches are reset to 1 in open-drain mode. Weak pullups are enabled during and after the reset. For Supply Monitor and power-on resets, the RSTb pin is driven low until the device exits the reset state. On exit from the reset state, the program counter (PC) is reset, and the system clock defaults to an internal oscillator. The Watchdog Timer is enabled, and program execution begins at location 0x0000.

Reset sources on the device include the following:

- Power-on reset
- External reset pin
- Comparator reset
- Software-triggered reset
- Supply monitor reset (monitors VDD supply)
- Watchdog timer reset
- Missing clock detector reset
- Flash error reset
- RTC0 alarm or oscillator failure

3.9 Debugging

The EFM8SB1 devices include an on-chip Silicon Labs 2-Wire (C2) debug interface to allow flash programming and in-system debugging with the production part installed in the end application. The C2 interface uses a clock signal (C2CK) and a bi-directional C2 data signal (C2D) to transfer information between the device and a host system. See the C2 Interface Specification for details on the C2 protocol.

3.10 Bootloader

All devices come pre-programmed with a UART bootloader. This bootloader resides in the last page of flash and can be erased if it is not needed.

The byte before the Lock Byte is the Bootloader Signature Byte. Setting this byte to a value of 0xA5 indicates the presence of the bootloader in the system. Any other value in this location indicates that the bootloader is not present in flash.

When a bootloader is present, the device will jump to the bootloader vector after any reset, allowing the bootloader to run. The bootloader then determines if the device should stay in bootload mode or jump to the reset vector located at 0x0000. When the bootloader is not present, the device will jump to the reset vector of 0x0000 after any reset.

Silicon Labs recommends the bootloader be disabled and the flash memory locked after the production programming step in applications where code security is a concern. More information about the factory bootloader protocol and usage can be found in *AN945: EFM8 Factory Bootloader User Guide*. Application notes can be found on the Silicon Labs website (www.silabs.com/8bit-appnotes) or within Simplicity Studio by using the [Application Notes] tile.

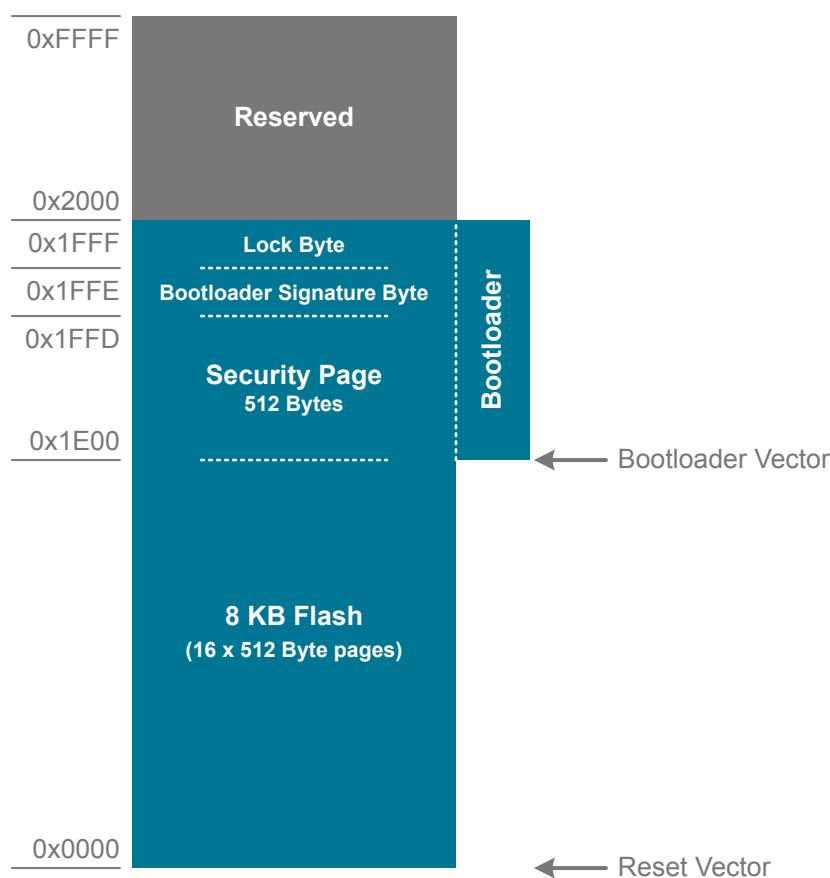

Figure 3.2. Flash Memory Map with Bootloader—8 kB Devices

Table 3.2. Summary of Pins for Bootloader Communication

Bootloader	Pins for Bootload Communication
UART	TX – P0.4
	RX – P0.5

Table 3.3. Summary of Pins for Bootload Mode Entry

Device Package	Pin for Bootload Mode Entry
QFN20	P2.7 / C2D
QFN24	P2.7 / C2D
QSOP24	P2.7 / C2D
CSP16	P2.7 / C2D

4. Electrical Specifications

4.1 Electrical Characteristics

All electrical parameters in all tables are specified under the conditions listed in [Table 4.1 Recommended Operating Conditions on page 16](#), unless stated otherwise.

4.1.1 Recommended Operating Conditions

Table 4.1. Recommended Operating Conditions

Parameter	Symbol	Test Condition	Min	Typ	Max	Unit
Operating Supply Voltage on VDD	V _{DD}		1.8	2.4	3.6	V
Minimum RAM Data Retention Voltage on VDD ¹	V _{RAM}	Not in Sleep Mode	—	1.4	—	V
		Sleep Mode	—	0.3	0.5	V
System Clock Frequency	f _{SYSCLK}		0	—	25	MHz
Operating Ambient Temperature	T _A		−40	—	85	°C
Note: 1. All voltages with respect to GND.						

4.1.2 Power Consumption

Table 4.2. Power Consumption

Parameter	Symbol	Conditions	Min	Typ	Max	Units
Digital Supply Current						
Normal Mode supply current - Full speed with code executing from flash ^{3, 4, 5}	I _{DD}	V _{DD} = 1.8–3.6 V, f _{SYSClk} = 24.5 MHz	—	3.6	4.5	mA
		V _{DD} = 1.8–3.6 V, f _{SYSClk} = 20 MHz	—	3.1	—	mA
		V _{DD} = 1.8–3.6 V, f _{SYSClk} = 32.768 kHz	—	84	—	μA
Normal Mode supply current frequency sensitivity ^{1, 3, 5}	I _{DDFREQ}	V _{DD} = 1.8–3.6 V, T = 25 °C, f _{SYSClk} < 14 MHz	—	174	—	μA/MHz
		V _{DD} = 1.8–3.6 V, T = 25 °C, f _{SYSClk} > 14 MHz	—	88	—	μA/MHz
Idle Mode supply current - Core halted with peripherals running ^{4, 6}	I _{DD}	V _{DD} = 1.8–3.6 V, f _{SYSClk} = 24.5 MHz	—	1.8	3.0	mA
		V _{DD} = 1.8–3.6 V, f _{SYSClk} = 20 MHz	—	1.4	—	mA
		V _{DD} = 1.8–3.6 V, f _{SYSClk} = 32.768 kHz	—	82	—	μA
Idle Mode Supply Current Frequency Sensitivity ^{1, 6}	I _{DDFREQ}	V _{DD} = 1.8–3.6 V, T = 25 °C	—	67	—	μA/MHz
Suspend Mode Supply Current	I _{DD}	V _{DD} = 1.8–3.6 V	—	77	—	μA
Sleep Mode Supply Current with RTC running from 32.768 kHz crystal	I _{DD}	1.8 V, T = 25 °C	—	0.60	—	μA
		3.6 V, T = 25 °C	—	0.80	—	μA
		1.8 V, T = 85 °C	—	0.80	—	μA
		3.6 V, T = 85 °C	—	1.00	—	μA
Sleep Mode Supply Current with RTC running from internal LFO	I _{DD}	1.8 V, T = 25 °C	—	0.30	—	μA
		3.6 V, T = 25 °C	—	0.50	—	μA
		1.8 V, T = 85 °C	—	0.50	—	μA
		3.6 V, T = 85 °C	—	0.80	—	μA
Sleep Mode Supply Current (RTC off)	I _{DD}	1.8 V, T = 25 °C	—	0.05	—	μA
		3.6 V, T = 25 °C	—	0.08	—	μA
		1.8 V, T = 85 °C	—	0.20	—	μA
		3.6 V, T = 85 °C	—	0.28	—	μA
V _{DD} Monitor Supply Current	I _{VMON}		—	7	—	μA
Oscillator Supply Current	I _{HFOSC0}	25 °C	—	300	—	μA

Parameter	Symbol	Conditions	Min	Typ	Max	Units
ADC0 Always-on Power Supply Current ⁷	I _{ADC}	300 ksps, 10-bit conversions or 75 ksps, 12-bit conversions Normal bias settings V _{DD} = 3.0 V	—	740	—	μA
		150 ksps, 10-bit conversions or 37.5 ksps 12-bit conversions Low power bias settings V _{DD} = 3.0 V	—	400	—	μA
Comparator 0 (CMP0) Supply Current	I _{CMP}	CPMD = 11	—	0.4	—	μA
		CPMD = 10	—	2.6	—	μA
		CPMD = 01	—	8.8	—	μA
		CPMD = 00	—	23	—	μA
Internal Fast-Settling 1.65V ADC0 Reference, Always-on ⁸	I _{VREFFS}	Normal Power Mode	—	260	—	μA
		Low Power Mode	—	140	—	μA
Temp sensor Supply Current	I _{TSENSE}		—	35	—	μA
Capacitive Sense Module (CS0) Supply Current	I _{CS0}	CS module bias current, 25 °C	—	50	60	μA
		CS module alone, maximum code output, 25 °C	—	90	125	μA
		Wake-on-CS threshold (suspend mode with regulator and CS module on) ⁹	—	130	180	μA
Programmable Current Reference (IREF0) Supply Current ¹⁰	I _{IREF0}	Current Source, Either Power Mode, Any Output Code	—	10	—	μA
		Low Power Mode, Current Sink IREF0DAT = 000001	—	1	—	μA
		Low Power Mode, Current Sink IREF0DAT = 111111	—	11	—	μA
		High Current Mode, Current Sink IREF0DAT = 000001	—	12	—	μA
		High Current Mode, Current Sink IREF0DAT = 111111	—	81	—	μA

Parameter	Symbol	Conditions	Min	Typ	Max	Units
Note:						
1. Based on device characterization data; Not production tested.						
2. SYSCLK must be at least 32 kHz to enable debugging.						
3. Digital Supply Current depends upon the particular code being executed. The values in this table are obtained with the CPU executing an “sjmp \$” loop, which is the compiled form of a while(1) loop in C. One iteration requires 3 CPU clock cycles, and the flash memory is read on each cycle. The supply current will vary slightly based on the physical location of the sjmp instruction and the number of flash address lines that toggle as a result. In the worst case, current can increase by up to 30% if the sjmp loop straddles a 64-byte flash address boundary (e.g., 0x007F to 0x0080). Real-world code with larger loops and longer linear sequences will have few transitions across the 64-byte address boundaries.						
4. Includes supply current from regulator and oscillator source (24.5 MHz high-frequency oscillator, 20 MHz low-power oscillator, 1 MHz external oscillator, or 32.768 kHz RTC oscillator).						
5. IDD can be estimated for frequencies < 14 MHz by simply multiplying the frequency of interest by the frequency sensitivity number for that range, then adding an offset of 84 μA. When using these numbers to estimate I _{DD} for > 14 MHz, the estimate should be the current at 25 MHz minus the difference in current indicated by the frequency sensitivity number. For example: V _{DD} = 3.0 V; F = 20 MHz, I _{DD} = 3.6 mA – (25 MHz – 20 MHz) x 0.088 mA/MHz = 3.16 mA assuming the same oscillator setting.						
6. Idle IDD can be estimated by taking the current at 25 MHz minus the difference in current indicated by the frequency sensitivity number. For example: V _{DD} = 3.0 V; F = 5 MHz, Idle I _{DD} = 1.75 mA – (25 MHz – 5 MHz) x 0.067 mA/MHz = 0.41 mA.						
7. ADC0 always-on power excludes internal reference supply current.						
8. The internal reference is enabled as-needed when operating the ADC in burst mode to save power.						
9. Includes only current from regulator, CS module, and MCU in suspend mode.						
10. IREF0 supply current only. Does not include current sourced or sunk from IREF0 output pin.						

4.1.3 Reset and Supply Monitor

Table 4.3. Reset and Supply Monitor

Parameter	Symbol	Test Condition	Min	Typ	Max	Unit
VDD Supply Monitor Threshold	V _{VDDM}	Reset Trigger	1.7	1.75	1.8	V
	V _{WARN}	Early Warning	1.8	1.85	1.9	V
VDD Supply Monitor Turn-On Time	t _{MON}		—	300	—	ns
Power-On Reset (POR) Monitor Threshold	V _{POR}	Rising Voltage on V _{DD}	—	1.75	—	V
		Falling Voltage on V _{DD}	0.75	1.0	1.3	V
V _{DD} Ramp Time	t _{RMP}	Time to V _{DD} ≥ 1.8 V	—	—	3	ms
Reset Delay from non-POR source	t _{RST}	Time between release of reset source and code execution	—	10	—	μs
Reset Delay from POR	t _{POR}	Relative to V _{DD} > V _{POR}	3	10	31	ms
RST Low Time to Generate Reset	t _{RSTL}		15	—	—	μs
Missing Clock Detector Response Time (final rising edge to reset)	t _{MCD}	F _{SYSCLK} > 1 MHz	100	650	1000	μs
Missing Clock Detector Trigger Frequency	F _{MCD}		—	7	10	kHz

4.1.4 Flash Memory

Table 4.4. Flash Memory

Parameter	Symbol	Test Condition	Min	Typ	Max	Units
Write Time ¹	t_{WRITE}	One Byte	57	64	71	μs
Erase Time ¹	t_{ERASE}	One Page	28	32	36	ms
Endurance (Write/Erase Cycles)	N_{WE}		20 k	100 k	—	Cycles
CRC Calculation Time	t_{CRC}	One 256-Byte Block SYSCLK = 24.5 MHz	—	21.5	—	μs

Note:

1. Does not include sequencing time before and after the write/erase operation, which may be multiple SYSCLK cycles.
2. Data Retention Information is published in the Quarterly Quality and Reliability Report.

4.1.5 Power Management Timing

Table 4.5. Power Management Timing

Parameter	Symbol	Test Condition	Min	Typ	Max	Units
Idle Mode Wake-up Time	t_{IDLEWK}		2	—	3	SYSCLKs
Suspend Mode Wake-up Time	$t_{SUS-PENDWK}$	CLKDIV = 0x00 Low Power or Precision Osc.	—	400	—	ns
Sleep Mode Wake-up Time	$t_{SLEEPWK}$		—	2	—	μs

4.1.6 Internal Oscillators

Table 4.6. Internal Oscillators

Parameter	Symbol	Test Condition	Min	Typ	Max	Unit
High Frequency Oscillator 0 (24.5 MHz)						
Oscillator Frequency	f_{HFOSC0}	Full Temperature and Supply Range	24	24.5	25	MHz
Low Power Oscillator (20 MHz)						
Oscillator Frequency	f_{LPOSC}	Full Temperature and Supply Range	18	20	22	MHz
Low Frequency Oscillator (16.4 kHz internal RTC oscillator)						
Oscillator Frequency	f_{LFOSC}	Full Temperature and Supply Range	13.1	16.4	19.7	kHz

4.1.7 Crystal Oscillator

Table 4.7. Crystal Oscillator

Parameter	Symbol	Test Condition	Min	Typ	Max	Unit
Crystal Frequency	f_{XTAL}		0.02	—	25	MHz
Crystal Drive Current	I_{XTAL}	XFCN = 0	—	0.5	—	μ A
		XFCN = 1	—	1.5	—	μ A
		XFCN = 2	—	4.8	—	μ A
		XFCN = 3	—	14	—	μ A
		XFCN = 4	—	40	—	μ A
		XFCN = 5	—	120	—	μ A
		XFCN = 6	—	550	—	μ A
		XFCN = 7	—	2.6	—	mA

4.1.8 External Clock Input

Table 4.8. External Clock Input

Parameter	Symbol	Test Condition	Min	Typ	Max	Unit
External Input CMOS Clock Frequency (at EXTCLK pin)	f_{CMOS}		0	—	25	MHz
External Input CMOS Clock High Time	t_{CMOSH}		18	—	—	ns
External Input CMOS Clock Low Time	t_{CMOSL}		18	—	—	ns

4.1.9 ADC

Table 4.9. ADC

Parameter	Symbol	Test Condition	Min	Typ	Max	Unit
Resolution	N _{bits}	12 Bit Mode	12			Bits
		10 Bit Mode	10			Bits
Throughput Rate	f _S	12 Bit Mode	—	—	75	ksps
		10 Bit Mode	—	—	300	ksps
Tracking Time	t _{TRK}	Initial Acquisition	1.5	—	—	us
		Subsequent Acquisitions (DC input, burst mode)	1.1	—	—	us
Power-On Time	t _{PWR}		1.5	—	—	μs
SAR Clock Frequency	f _{SAR}	High Speed Mode,	—	—	8.33	MHz
		Low Power Mode	—	—	4.4	MHz
Conversion Time	T _{CNV}	10-Bit Conversion	13	—	—	Clocks
Sample/Hold Capacitor	C _{SAR}	Gain = 1	—	16	—	pF
		Gain = 0.5	—	13	—	pF
Input Pin Capacitance	C _{IN}		—	20	—	pF
Input Mux Impedance	R _{MUX}		—	5	—	kΩ
Voltage Reference Range	V _{REF}		1	—	V _{DD}	V
Input Voltage Range ¹	V _{IN}	Gain = 1	0	—	V _{REF}	V
		Gain = 0.5	0	—	2 x V _{REF}	V
Power Supply Rejection Ratio	PSRR _{ADC}	Internal High Speed VREF	—	67	—	dB
		External VREF	—	74	—	dB
DC Performance						
Integral Nonlinearity	INL	12 Bit Mode	—	±1	±1.5	LSB
		10 Bit Mode	—	±0.5	±1	LSB
Differential Nonlinearity (Guaranteed Monotonic)	DNL	12 Bit Mode	—	±0.8	±1	LSB
		10 Bit Mode	—	±0.5	±1	LSB
Offset Error	E _{OFF}	12 Bit Mode, VREF = 1.65 V	-3	0	3	LSB
		10 Bit Mode, VREF = 1.65 V	-2	0	2	LSB
Offset Temperature Coefficient	T _{C_{OFF}}		—	0.004	—	LSB/°C
Slope Error	E _M	12 Bit Mode	—	±0.02	±0.1	%
		10 Bit Mode	—	±0.06	±0.24	%
Dynamic Performance 10 kHz Sine Wave Input 1dB below full scale, Max throughput						
Signal-to-Noise	SNR	12 Bit Mode	62	65	—	dB
		10 Bit Mode	54	58	—	dB

Parameter	Symbol	Test Condition	Min	Typ	Max	Unit
Signal-to-Noise Plus Distortion	SNDR	12 Bit Mode	62	65	—	dB
		10 Bit Mode	54	58	—	dB
Total Harmonic Distortion (Up to 5th Harmonic)	THD	12 Bit Mode	—	-76	—	dB
		10 Bit Mode	—	-73	—	dB
Spurious-Free Dynamic Range	SFDR	12 Bit Mode	—	82	—	dB
		10 Bit Mode	—	75	—	dB

Note:

1. Absolute input pin voltage is limited by the V_{DD} supply.
2. INL and DNL specifications for 12-bit mode do not include the first or last four ADC codes.
3. The maximum code in 12-bit mode is 0xFFFC. The Full Scale Error is referenced from the maximum code.

4.1.10 Voltage Reference

Table 4.10. Voltage Reference

Parameter	Symbol	Test Condition	Min	Typ	Max	Unit
Internal Fast Settling Reference						
Output Voltage	V_{REFFS}		1.62	1.65	1.68	V
Temperature Coefficient	TC_{REFFS}		—	50	—	ppm/°C
Turn-on Time	t_{REFFS}		—	—	1.5	μs
Power Supply Rejection	$PSRR_{REFFS}$		—	400	—	ppm/V
External Reference						
Input Voltage	V_{EXTREF}		1	—	V_{DD}	V
Input Current	I_{EXTREF}	Sample Rate = 300 ksps; $V_{REF} = 3.0$ V	—	5.25	—	μA

4.1.11 Temperature Sensor

Table 4.11. Temperature Sensor

Parameter	Symbol	Test Condition	Min	Typ	Max	Unit
Offset	V _{OFF}	T _A = 0 °C	—	940	—	mV
Offset Error ¹	E _{OFF}	T _A = 0 °C	—	18	—	mV
Slope	M		—	3.40	—	mV/°C
Slope Error ¹	E _M		—	40	—	μV/°C
Linearity			—	±1	—	°C
Turn-on Time	t _{PWR}		—	1.8	—	μs

Note:

1. Represents one standard deviation from the mean.

4.1.12 Comparators

Table 4.12. Comparators

Parameter	Symbol	Test Condition	Min	Typ	Max	Unit
Response Time, CPMD = 00 (Highest Speed)	t_{RESP0}	+100 mV Differential	—	120	—	ns
		-100 mV Differential	—	110	—	ns
Response Time, CPMD = 11 (Low- est Power)	t_{RESP3}	+100 mV Differential	—	1.25	—	μ s
		-100 mV Differential	—	3.2	—	μ s
Positive Hysteresis Mode 0 (CPMD = 00)	HYS_{CP+}	CPHYP = 00	—	0.4	—	mV
		CPHYP = 01	—	8	—	mV
		CPHYP = 10	—	16	—	mV
		CPHYP = 11	—	32	—	mV
Negative Hysteresis Mode 0 (CPMD = 00)	HYS_{CP-}	CPHYN = 00	—	-0.4	—	mV
		CPHYN = 01	—	-8	—	mV
		CPHYN = 10	—	-16	—	mV
		CPHYN = 11	—	-32	—	mV
Positive Hysteresis Mode 1 (CPMD = 01)	HYS_{CP+}	CPHYP = 00	—	0.5	—	mV
		CPHYP = 01	—	6	—	mV
		CPHYP = 10	—	12	—	mV
		CPHYP = 11	—	24	—	mV
Negative Hysteresis Mode 1 (CPMD = 01)	HYS_{CP-}	CPHYN = 00	—	-0.5	—	mV
		CPHYN = 01	—	-6	—	mV
		CPHYN = 10	—	-12	—	mV
		CPHYN = 11	—	-24	—	mV
Positive Hysteresis Mode 2 (CPMD = 10)	HYS_{CP+}	CPHYP = 00	—	0.7	—	mV
		CPHYP = 01	—	4.5	—	mV
		CPHYP = 10	—	9	—	mV
		CPHYP = 11	—	18	—	mV
Negative Hysteresis Mode 2 (CPMD = 10)	HYS_{CP-}	CPHYN = 00	—	-0.6	—	mV
		CPHYN = 01	—	-4.5	—	mV
		CPHYN = 10	—	-9	—	mV
		CPHYN = 11	—	-18	—	mV
Positive Hysteresis Mode 3 (CPMD = 11)	HYS_{CP+}	CPHYP = 00	—	1.5	—	mV
		CPHYP = 01	—	4	—	mV
		CPHYP = 10	—	8	—	mV
		CPHYP = 11	—	16	—	mV

Parameter	Symbol	Test Condition	Min	Typ	Max	Unit
Negative Hysteresis Mode 3 (CPMD = 11)	HYS _{CP-}	CPHYN = 00	—	-1.5	—	mV
		CPHYN = 01	—	-4	—	mV
		CPHYN = 10	—	-8	—	mV
		CPHYN = 11	—	-16	—	mV
Input Range (CP+ or CP-)	V _{IN}		-0.25	—	V _{DD} +0.25	V
Input Pin Capacitance	C _{CP}		—	12	—	pF
Common-Mode Rejection Ratio	CMRR _{CP}		—	70	—	dB
Power Supply Rejection Ratio	PSRR _{CP}		—	72	—	dB
Input Offset Voltage	V _{OFF}	T _A = 25 °C	-10	0	10	mV
Input Offset Tempco	TC _{OFF}		—	3.5	—	μV/°C

4.1.13 Programmable Current Reference (IREF0)

Table 4.13. Programmable Current Reference (IREF0)

Parameter	Symbol	Conditions	Min	Typ	Max	Units
Static Performance						
Resolution	N _{bits}		6			bits
Output Compliance Range	V _{IOUT}	Low Power Mode, Source	0	—	V _{DD} - 0.4	V
		High Current Mode, Source	0	—	V _{DD} - 0.8	V
		Low Power Mode, Sink	0.3	—	V _{DD}	V
		High Current Mode, Sink	0.8	—	V _{DD}	V
Integral Nonlinearity	INL		—	<±0.2	±1.0	LSB
Differential Nonlinearity	DNL		—	<±0.2	±1.0	LSB
Offset Error	E _{OFF}		—	<±0.1	±0.5	LSB
Full Scale Error	E _{FS}	Low Power Mode, Source	—	—	±5	%
		High Current Mode, Source	—	—	±6	%
		Low Power Mode, Sink	—	—	±8	%
		High Current Mode, Sink	—	—	±8	%
Absolute Current Error	E _{ABS}	Low Power Mode Sourcing 20 μA	—	<±1	±3	%
Dynamic Performance						
Output Settling Time to 1/2 LSB	t _{SETTLE}		—	300	—	ns
Startup Time	t _{PWR}		—	1	—	μs
Note:						
1. The PCA block may be used to improve IREF0 resolution by PWMing the two LSBs.						

4.1.14 Capacitive Sense (CS0)

Table 4.14. Capacitive Sense (CS0)

Parameter	Symbol	Conditions	Min	Typ	Max	Units
Single Conversion Time ¹	t _{CNV}	12-bit Mode	20	25	40	μs
		13-bit Mode (default)	21	27	42.5	μs
		14-bit Mode	23	29	45	μs
		16-bit Mode	26	33	50	μs
Number of Channels	N _{CHAN}	24-pin Packages	14			Channels
		20-pin Packages	13			Channels
		16-pin Packages	12			Channels
Capacitance per Code	C _{LSB}	Default Configuration, 16-bit codes	—	1	—	fF
Maximum External Capacitive Load	C _{EXTMAX}	CS0CG = 111b (Default)	—	45	—	pF
		CS0CG = 000b	—	500	—	pF
Maximum External Series Impedance	R _{EXTMAX}	CS0CG = 111b (Default)	—	50	—	kΩ

Note:

1. Conversion time is specified with the default configuration.
2. RMS Noise is equivalent to one standard deviation. Peak-to-peak noise encompasses ±3.3 standard deviations. The RMS noise value is specified with the default configuration.

4.1.15 Port I/O

Table 4.15. Port I/O

Parameter	Symbol	Test Condition	Min	Typ	Max	Unit
Output High Voltage (High Drive) ¹	V _{OH}	I _{OH} = -3 mA	V _{DD} - 0.7	—	—	V
Output Low Voltage (High Drive) ¹	V _{OL}	I _{OL} = 8.5 mA	—	—	0.6	V
Output High Voltage (Low Drive) ¹	V _{OH}	I _{OH} = -1 mA	V _{DD} - 0.7	—	—	V
Output Low Voltage (Low Drive) ¹	V _{OL}	I _{OL} = 1.4 mA	—	—	0.6	V
Input High Voltage	V _{IH}	V _{DD} = 2.0 to 3.6 V	V _{DD} - 0.6	—	—	V
		V _{DD} = 1.8 to 2.0 V	0.7 x V _{DD}	—	—	V
Input Low Voltage	V _{IL}	V _{DD} = 2.0 to 3.6 V	—	—	0.6	V
		V _{DD} = 1.8 to 2.0 V	—	—	0.3 x V _{DD}	V
Weak Pull-Up Current	I _{PU}	V _{DD} = 1.8 V V _{IN} = 0 V	—	-4	—	μA
		V _{DD} = 3.6 V V _{IN} = 0 V	-35	-20	—	μA
Input Leakage	I _{LK}	Weak pullup disabled or pin in analog mode	-1	—	1	μA

Note:

1. See [Figure 4.3 Typical V_{OH} Curves](#) on page 32 and [Figure 4.4 Typical V_{OL} Curves](#) on page 33 for more information.

4.1.16 SMBus

Table 4.16. SMBus Peripheral Timing Performance (Master Mode)

Parameter	Symbol	Test Condition	Min	Typ	Max	Unit
Standard Mode (100 kHz Class)						
I2C Operating Frequency	f_{I2C}		0	—	70^2	kHz
SMBus Operating Frequency	f_{SMB}		40^1	—	70^2	kHz
Bus Free Time Between STOP and START Conditions	t_{BUF}		9.4	—	—	μs
Hold Time After (Repeated) START Condition	$t_{HD:STA}$		4.7	—	—	μs
Repeated START Condition Setup Time	$t_{SU:STA}$		9.4	—	—	μs
STOP Condition Setup Time	$t_{SU:STO}$		9.4	—	—	μs
Data Hold Time	$t_{HD:DAT}$		489^3	—	—	ns
Data Setup Time	$t_{SU:DAT}$		448^3	—	—	ns
Detect Clock Low Timeout	$t_{TIMEOUT}$		25	—	—	ms
Clock Low Period	t_{LOW}		4.7	—	—	μs
Clock High Period	t_{HIGH}		9.4	—	50^4	μs
Fast Mode (400 kHz Class)						
I2C Operating Frequency	f_{I2C}		0	—	255^2	kHz
SMBus Operating Frequency	f_{SMB}		40^1	—	255^2	kHz
Bus Free Time Between STOP and START Conditions	t_{BUF}		2.6	—	—	μs
Hold Time After (Repeated) START Condition	$t_{HD:STA}$		1.3	—	—	μs
Repeated START Condition Setup Time	$t_{SU:STA}$		2.6	—	—	μs
STOP Condition Setup Time	$t_{SU:STO}$		2.6	—	—	μs
Data Hold Time	$t_{HD:DAT}$		489^3	—	—	ns
Data Setup Time	$t_{SU:DAT}$		448^3	—	—	ns
Detect Clock Low Timeout	$t_{TIMEOUT}$		25	—	—	ms
Clock Low Period	t_{LOW}		1.3	—	—	μs
Clock High Period	t_{HIGH}		2.6	—	50^4	μs

Parameter	Symbol	Test Condition	Min	Typ	Max	Unit
Note:						
1. The minimum SMBus frequency is limited by the maximum Clock High Period requirement of the SMBus specification.						
2. The maximum I2C and SMBus frequencies are limited by the minimum Clock Low Period requirements of their respective specifications. The maximum frequency cannot be achieved with all combinations of oscillators and dividers available, but the effective frequency must not exceed 256 kHz.						
3. Data setup and hold timing at 25 MHz or lower with EXTHOLD set to 1.						
4. SMBus has a maximum requirement of 50 μ s for Clock High Period. Operating frequencies lower than 40 kHz will be longer than 50 μ s. I2C can support periods longer than 50 μ s.						

Table 4.17. SMBus Peripheral Timing Formulas (Master Mode)

Parameter	Symbol	Clocks
SMBus Operating Frequency	f_{SMB}	$f_{CSO} / 3$
Bus Free Time Between STOP and START Conditions	t_{BUF}	$2 / f_{CSO}$
Hold Time After (Repeated) START Condition	$t_{HD:STA}$	$1 / f_{CSO}$
Repeated START Condition Setup Time	$t_{SU:STA}$	$2 / f_{CSO}$
STOP Condition Setup Time	$t_{SU:STO}$	$2 / f_{CSO}$
Clock Low Period	t_{LOW}	$1 / f_{CSO}$
Clock High Period	t_{HIGH}	$2 / f_{CSO}$

Note:

- f_{CSO} is the SMBus peripheral clock source overflow frequency.

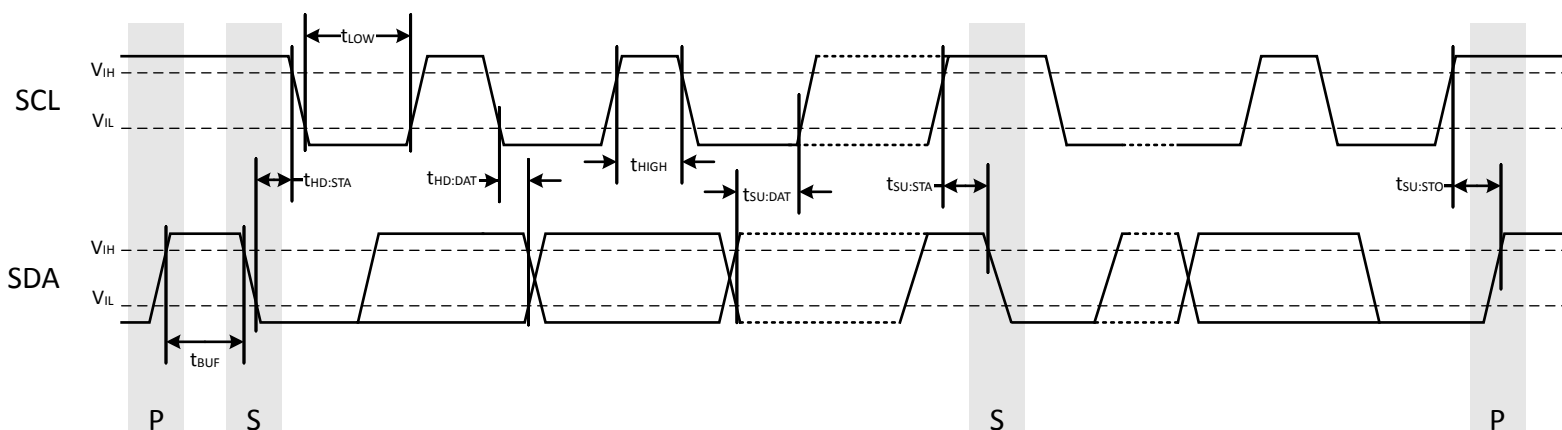

Figure 4.1. SMBus Peripheral Timing Diagram (Master Mode)

4.2 Thermal Conditions

Table 4.18. Thermal Conditions

Parameter	Symbol	Test Condition	Min	Typ	Max	Unit
Thermal Resistance*	θ_{JA}	QFN-24 Packages	—	35	—	°C/W
		QFN-20 Packages	—	60	—	°C/W
		QSOP-24 Packages	—	65	—	°C/W
Note:						
1. Thermal resistance assumes a multi-layer PCB with any exposed pad soldered to a PCB pad.						

4.3 Absolute Maximum Ratings

Stresses above those listed in [Table 4.19 Absolute Maximum Ratings on page 31](#) may cause permanent damage to the device. This is a stress rating only and functional operation of the devices at those or any other conditions above those indicated in the operation listings of this specification is not implied. Exposure to maximum rating conditions for extended periods may affect device reliability. For more information on the available quality and reliability data, see the Quality and Reliability Monitor Report at <http://www.silabs.com/support/quality/pages/default.aspx>.

Table 4.19. Absolute Maximum Ratings

Parameter	Symbol	Test Condition	Min	Max	Unit
Ambient Temperature Under Bias	T_{BIAS}		-55	125	°C
Storage Temperature	T_{STG}		-65	150	°C
Voltage on V_{DD}	V_{DD}		GND-0.3	4.0	V
Voltage on I/O pins or RSTb	V_{IN}		GND-0.3	$V_{DD} + 0.3$	V
Total Current Sunk into Supply Pin	I_{VDD}		—	400	mA
Total Current Sourced out of Ground Pin	I_{GND}		400	—	mA
Current Sourced or Sunk by Any I/O Pin or RSTb	I_{IO}		-100	100	mA
Maximum Total Current through all Port Pins	I_{IOTOT}		—	200	mA
Operating Junction Temperature	T_J		-40	105	°C
Exposure to maximum rating conditions for extended periods may affect device reliability.					

4.4 Typical Performance Curves

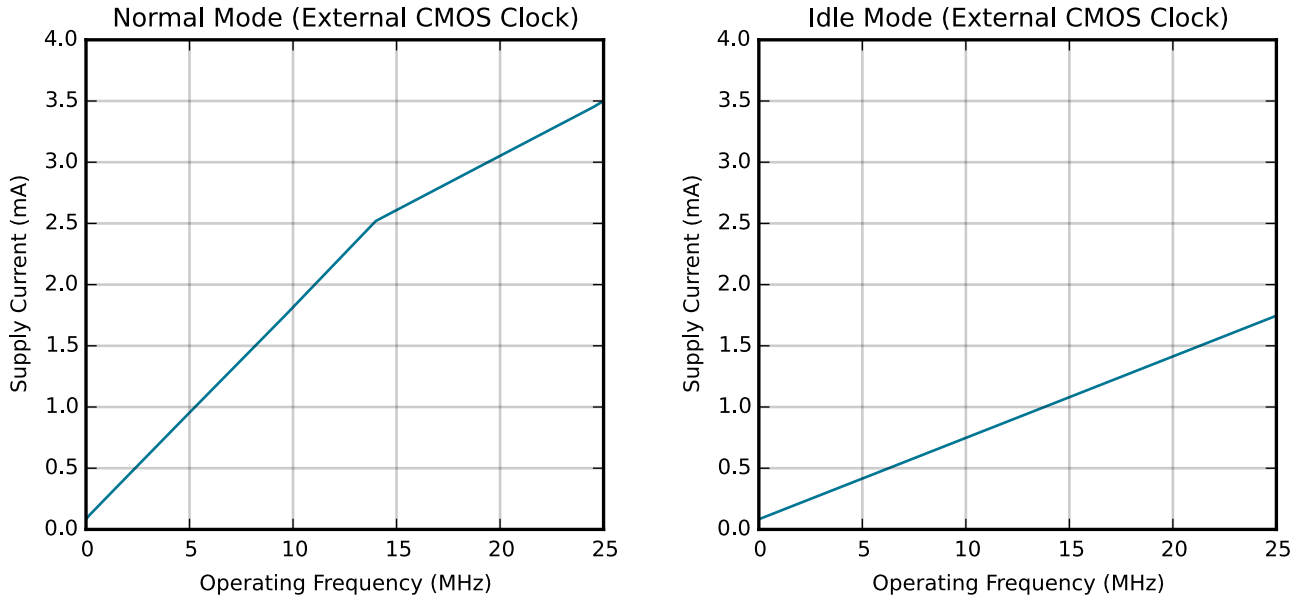

Figure 4.2. Typical Operating Supply Current (full supply voltage range)

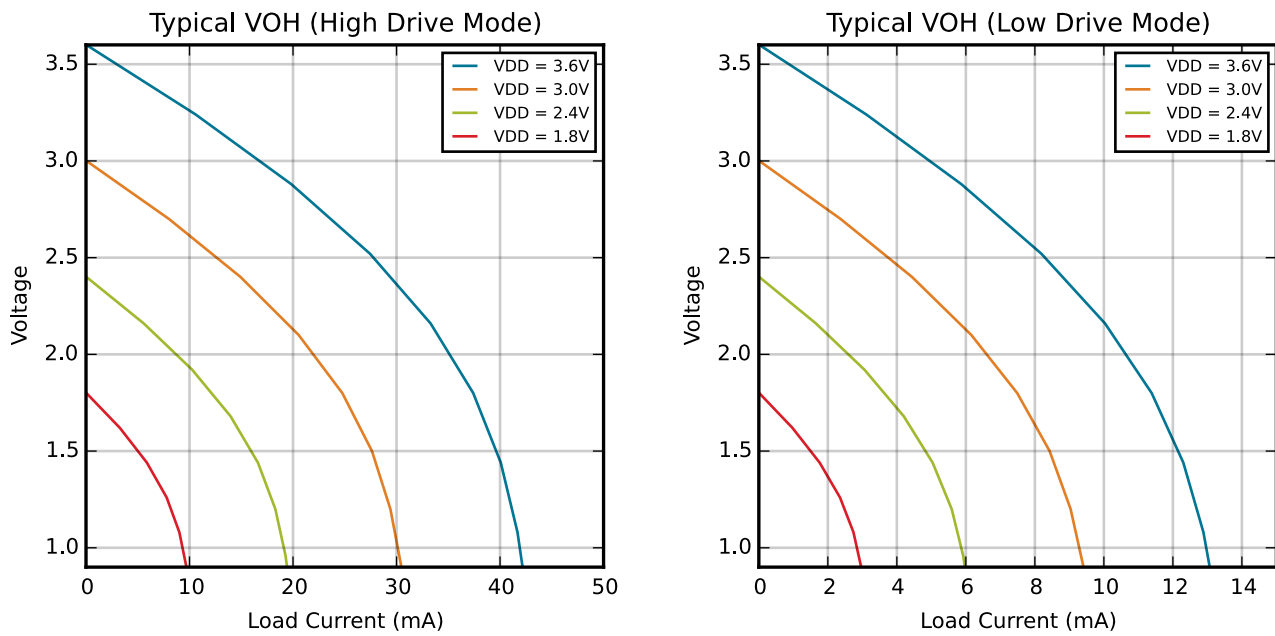

Figure 4.3. Typical V_{OH} Curves

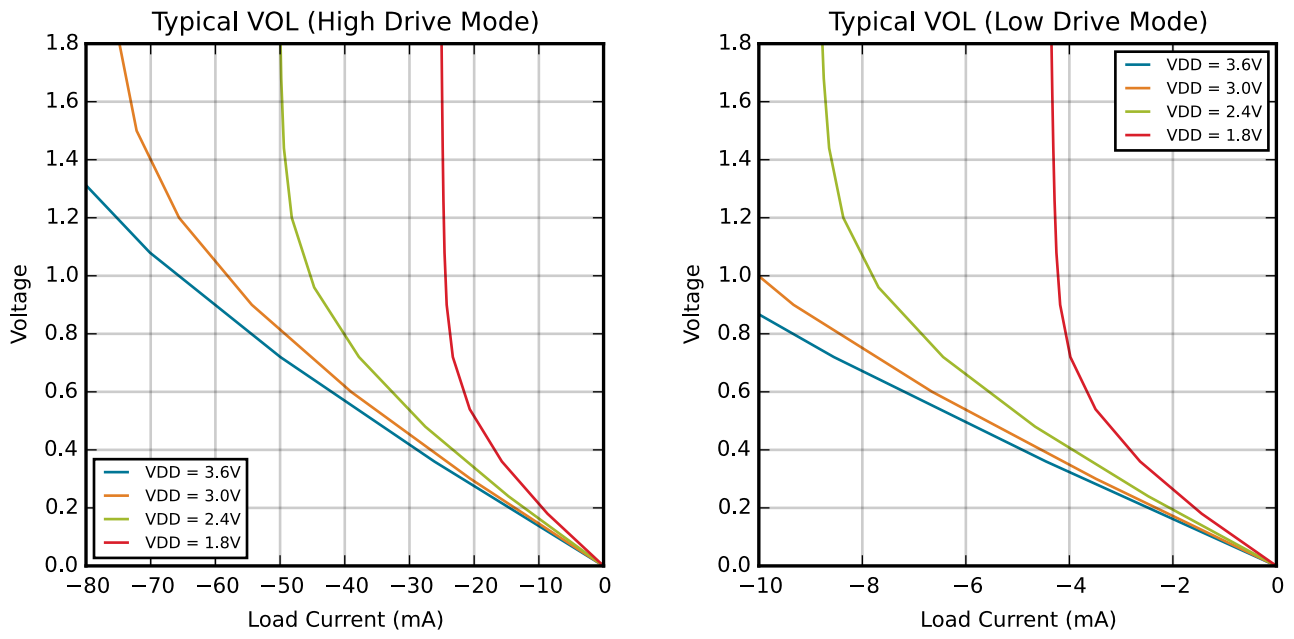

Figure 4.4. Typical V_{OL} Curves

5. Typical Connection Diagrams

5.1 Power

Figure 5.1 Power Connection Diagram on page 34 shows a typical connection diagram for the power pins of the EFM8SB1 devices.

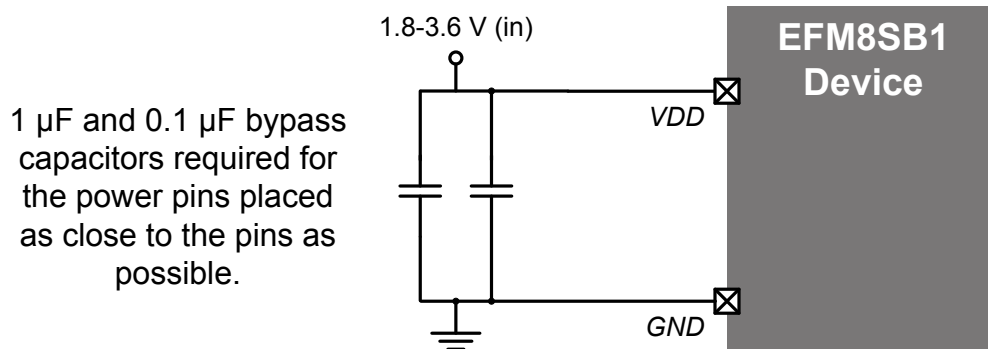

Figure 5.1. Power Connection Diagram

5.2 Debug

The diagram below shows a typical connection diagram for the debug connections pins. The pin sharing resistors are only required if the functionality on the C2D (a GPIO pin) and the C2CK (RSTb) is routed to external circuitry. For example, if the RSTb pin is connected to an external switch with debouncing filter or if the GPIO sharing with the C2D pin is connected to an external circuit, the pin sharing resistors and connections to the debug adapter must be placed on the hardware. Otherwise, these components and connections can be omitted.

For more information on debug connections, see the example schematics and information available in *AN124: Pin Sharing Techniques for the C2 Interface*. Application notes can be found on the Silicon Labs website (<http://www.silabs.com/8bit-appnotes>) or in Simplicity Studio.

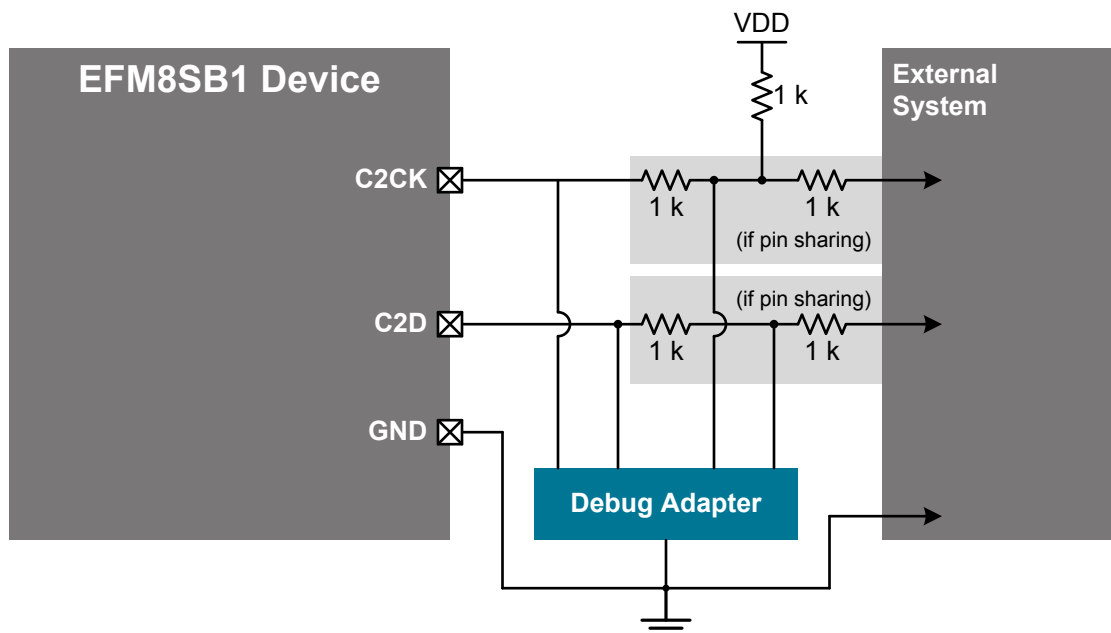

Figure 5.2. Debug Connection Diagram

5.3 Other Connections

Other components or connections may be required to meet the system-level requirements. Application Note *AN203: 8-bit MCU Printed Circuit Board Design Notes* contains detailed information on these connections. Application Notes can be accessed on the Silicon Labs website (www.silabs.com/8bit-appnotes).

6. Pin Definitions

6.1 EFM8SB1x-QFN20 Pin Definitions

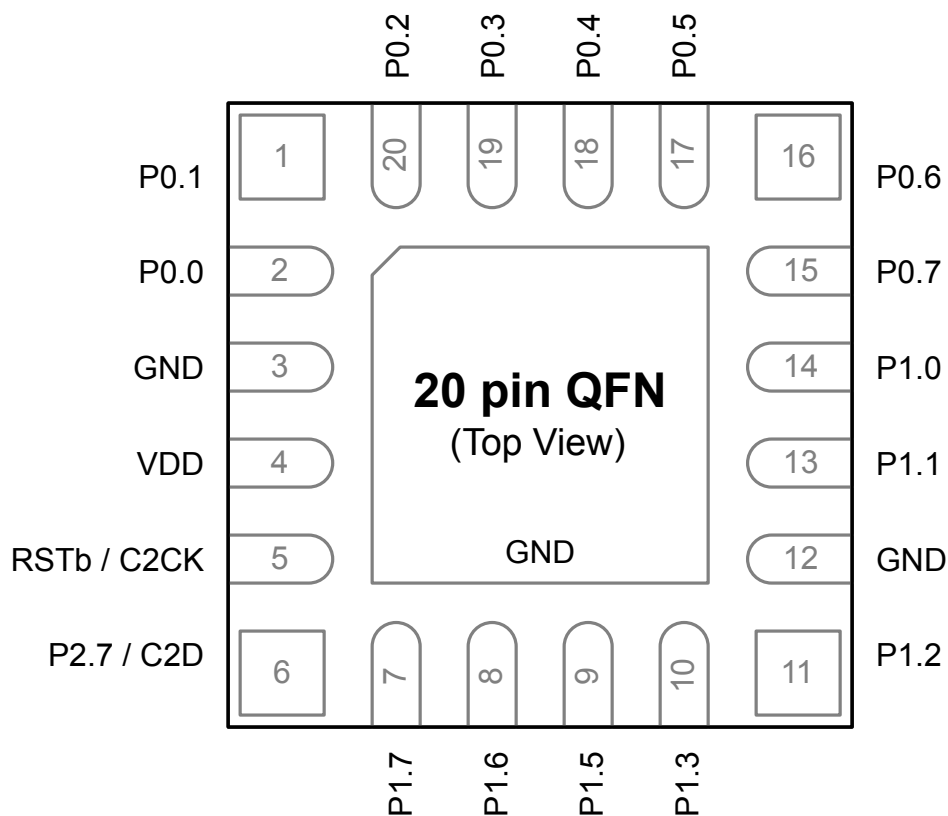

Figure 6.1. EFM8SB1x-QFN20 Pinout

Table 6.1. Pin Definitions for EFM8SB1x-QFN20

Pin Number	Pin Name	Description	Crossbar Capability	Additional Digital Functions	Analog Functions
1	P0.1	Multifunction I/O	Yes	P0MAT.1 INT0.1 INT1.1	ADC0.1 CS0.1 AGND
2	P0.0	Multifunction I/O	Yes	P0MAT.0 INT0.0 INT1.0	CS0.0 VREF
3	GND	Ground			
4	VDD	Supply Power Input			

Pin Number	Pin Name	Description	Crossbar Capability	Additional Digital Functions	Analog Functions
5	RSTb / C2CK	Active-low Reset / C2 Debug Clock			
6	P2.7 / C2D	Multifunction I/O / C2 Debug Data			
7	P1.7	Multifunction I/O	Yes	P1MAT.7	XTAL4
8	P1.6	Multifunction I/O	Yes	P1MAT.6	XTAL3
9	P1.5	Multifunction I/O	Yes	P1MAT.5	CS0.13
10	P1.3	Multifunction I/O	Yes	P1MAT.3	ADC0.11 CS0.11
11	P1.2	Multifunction I/O	Yes	P1MAT.2	ADC0.10 CS0.10
12	GND	Ground			
13	P1.1	Multifunction I/O	Yes	P1MAT.1	CMP0N.4 CS0.9
14	P1.0	Multifunction I/O	Yes	P1MAT.0	CMP0P.4 CS0.8
15	P0.7	Multifunction I/O	Yes	P0MAT.7 INT0.7 INT1.7	ADC0.7 CS0.7 IREF0
16	P0.6	Multifunction I/O	Yes	P0MAT.6 CNVSTR INT0.6 INT1.6	ADC0.6 CS0.6
17	P0.5	Multifunction I/O	Yes	P0MAT.5 INT0.5 INT1.5	ADC0.5 CS0.5
18	P0.4	Multifunction I/O	Yes	P0MAT.4 INT0.4 INT1.4	ADC0.4 CS0.4
19	P0.3	Multifunction I/O	Yes	P0MAT.3 EXTCLK WAKEOUT INT0.3 INT1.3	ADC0.3 CS0.3 XTAL2

Pin Number	Pin Name	Description	Crossbar Capability	Additional Digital Functions	Analog Functions
20	P0.2	Multifunction I/O	Yes	P0MAT.2 RTCOUT INT0.2 INT1.2	ADC0.2 CS0.2 XTAL1
Center	GND	Ground			

6.2 EFM8SB1x-QFN24 Pin Definitions

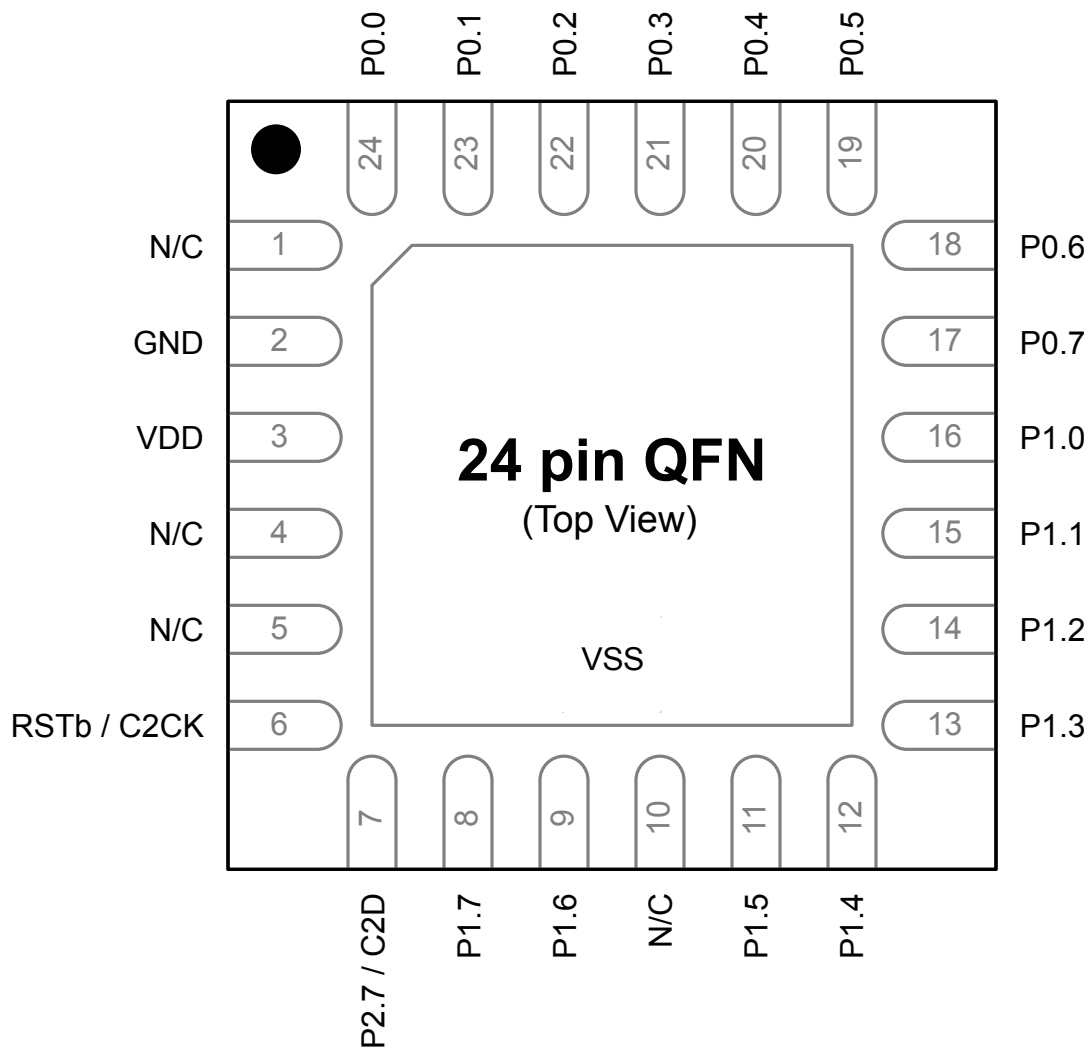

Figure 6.2. EFM8SB1x-QFN24 Pinout

Table 6.2. Pin Definitions for EFM8SB1x-QFN24

Pin Number	Pin Name	Description	Crossbar Capability	Additional Digital Functions	Analog Functions
1	N/C	No Connection			
2	GND	Ground			
3	VDD	Supply Power Input			
4	N/C	No Connection			
5	N/C	No Connection			

Pin Number	Pin Name	Description	Crossbar Capability	Additional Digital Functions	Analog Functions
6	RSTb / C2CK	Active-low Reset / C2 Debug Clock			
7	P2.7 / C2D	Multifunction I/O / C2 Debug Data			
8	P1.7	Multifunction I/O	Yes	P1MAT.7	XTAL4
9	P1.6	Multifunction I/O	Yes	P1MAT.6	XTAL3
10	N/C	No Connection			
11	P1.5	Multifunction I/O	Yes	P1MAT.5	CS0.13
12	P1.4	Multifunction I/O	Yes	P1MAT.4	ADC0.12 CS0.12
13	P1.3	Multifunction I/O	Yes	P1MAT.3	ADC0.11 CS0.11
14	P1.2	Multifunction I/O	Yes	P1MAT.2	ADC0.10 CS0.10
15	P1.1	Multifunction I/O	Yes	P1MAT.1	CMP0N.4 CS0.9
16	P1.0	Multifunction I/O	Yes	P1MAT.0	CMP0P.4 CS0.8
17	P0.7	Multifunction I/O	Yes	P0MAT.7 INT0.7 INT1.7	ADC0.7 CS0.7 IREF0
18	P0.6	Multifunction I/O	Yes	P0MAT.6 CNVSTR INT0.6 INT1.6	ADC0.6 CS0.6
19	P0.5	Multifunction I/O	Yes	P0MAT.5 INT0.5 INT1.5	ADC0.5 CS0.5
20	P0.4	Multifunction I/O	Yes	P0MAT.4 INT0.4 INT1.4	ADC0.4 CS0.4
21	P0.3	Multifunction I/O	Yes	P0MAT.3 EXTCLK WAKEOUT INT0.3 INT1.3	ADC0.3 CS0.3 XTAL2

Pin Number	Pin Name	Description	Crossbar Capability	Additional Digital Functions	Analog Functions
22	P0.2	Multifunction I/O	Yes	P0MAT.2 RTCOUT INT0.2 INT1.2	ADC0.2 CS0.2 XTAL1
23	P0.1	Multifunction I/O	Yes	P0MAT.1 INT0.1 INT1.1	ADC0.1 CS0.1 AGND
24	P0.0	Multifunction I/O	Yes	P0MAT.0 INT0.0 INT1.0	CS0.0 VREF
Center	GND	Ground			

6.3 EFM8SB1x-QSOP24 Pin Definitions

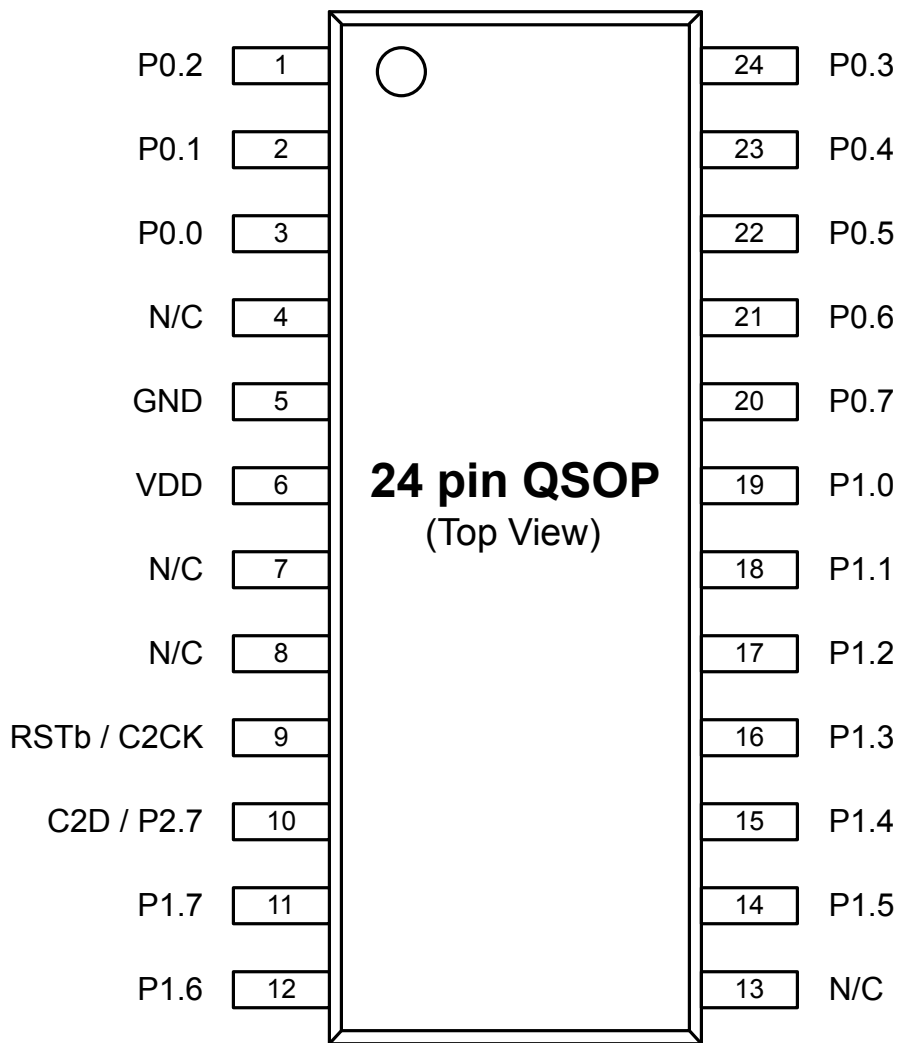

Figure 6.3. EFM8SB1x-QSOP24 Pinout

Table 6.3. Pin Definitions for EFM8SB1x-QSOP24

Pin Number	Pin Name	Description	Crossbar Capability	Additional Digital Functions	Analog Functions
1	P0.2	Multifunction I/O	Yes	P0MAT.2 RTCOUT INT0.2 INT1.2	ADC0.2 CS0.2 XTAL1
2	P0.1	Multifunction I/O	Yes	P0MAT.1 INT0.1 INT1.1	ADC0.1 CS0.1 AGND

Pin Number	Pin Name	Description	Crossbar Capability	Additional Digital Functions	Analog Functions
3	P0.0	Multifunction I/O	Yes	P0MAT.0 INT0.0 INT1.0	CS0.0 VREF
4	N/C	No Connection			
5	GND	Ground			
6	VDD	Supply Power Input			
7	N/C	No Connection			
8	N/C	No Connection			
9	RSTb / C2CK	Active-low Reset / C2 Debug Clock			
10	P2.7 / C2D	Multifunction I/O / C2 Debug Data			
11	P1.7	Multifunction I/O	Yes	P1MAT.7	XTAL4
12	P1.6	Multifunction I/O	Yes	P1MAT.6	XTAL3
13	N/C	No Connection			
14	P1.5	Multifunction I/O	Yes	P1MAT.5	CS0.13
15	P1.4	Multifunction I/O	Yes	P1MAT.4	ADC0.12 CS0.12
16	P1.3	Multifunction I/O	Yes	P1MAT.3	ADC0.11 CS0.11
17	P1.2	Multifunction I/O	Yes	P1MAT.2	ADC0.10 CS0.10
18	P1.1	Multifunction I/O	Yes	P1MAT.1	CMP0N.4 CS0.9
19	P1.0	Multifunction I/O	Yes	P1MAT.0	CMP0P.4 CS0.8
20	P0.7	Multifunction I/O	Yes	P0MAT.7 INT0.7 INT1.7	ADC0.7 CS0.7 IREF0
21	P0.6	Multifunction I/O	Yes	P0MAT.6 CNVSTR INT0.6 INT1.6	ADC0.6 CS0.6
22	P0.5	Multifunction I/O	Yes	P0MAT.5 INT0.5 INT1.5	ADC0.5 CS0.5

Pin Number	Pin Name	Description	Crossbar Capability	Additional Digital Functions	Analog Functions
23	P0.4	Multifunction I/O	Yes	P0MAT.4 INT0.4 INT1.4	ADC0.4 CS0.4
24	P0.3	Multifunction I/O	Yes	P0MAT.3 EXTCLK WAKEOUT INT0.3 INT1.3	ADC0.3 CS0.3 XTAL2

6.4 EFM8SB1x-CSP16 Pin Definitions

CSP devices can be handled and soldered using industry standard surface mount assembly techniques. However, because CSP devices are essentially a piece of silicon and are not encapsulated in plastic, they are susceptible to mechanical damage and may be sensitive to light. When CSP packages must be used in an environment exposed to light, it may be necessary to cover the top and sides with an opaque material.

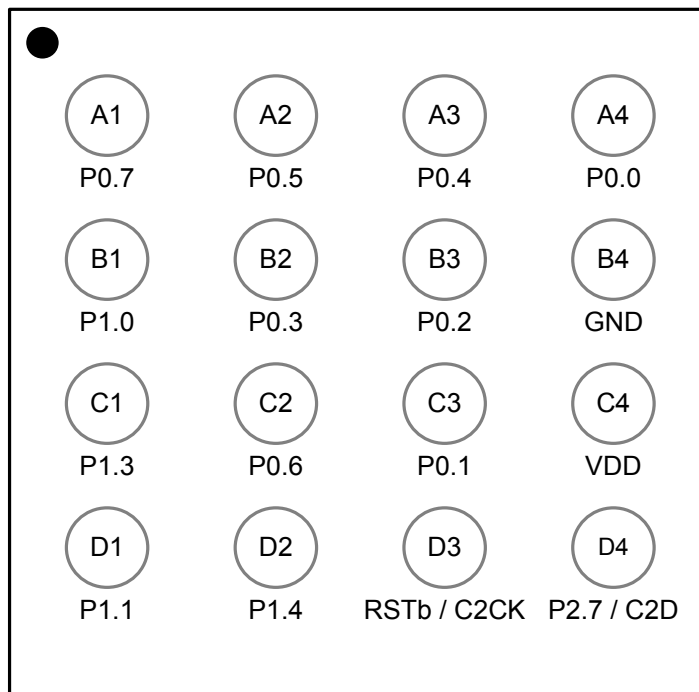

16 pin CSP
(Top View)

Figure 6.4. EFM8SB1x-CSP16 Pinout

Table 6.4. Pin Definitions for EFM8SB1x-CSP16

Pin Number	Pin Name	Description	Crossbar Capability	Additional Digital Functions	Analog Functions
A1	P0.7	Multifunction I/O	Yes	P0MAT.7 INT0.7 INT1.7	ADC0.7 CS0.7 IREF0
A2	P0.5	Multifunction I/O	Yes	P0MAT.5 INT0.5 INT1.5	ADC0.5 CS0.5
A3	P0.4	Multifunction I/O	Yes	P0MAT.4 INT0.4 INT1.4	ADC0.4 CS0.4

Pin Number	Pin Name	Description	Crossbar Capability	Additional Digital Functions	Analog Functions
A4	P0.0	Multifunction I/O	Yes	P0MAT.0 INT0.0 INT1.0	CS0.0 VREF
B1	P1.0	Multifunction I/O	Yes	P1MAT.0	CMP0P.4 CS0.8
B2	P0.3	Multifunction I/O	Yes	P0MAT.3 EXTCLK WAKEOUT INT0.3 INT1.3	ADC0.3 CS0.3 XTAL2
B3	P0.2	Multifunction I/O	Yes	P0MAT.2 RTCOU INT0.2 INT1.2	ADC0.2 CS0.2 XTAL1
B4	GND	Ground			
C1	P1.3	Multifunction I/O	Yes	P1MAT.3	ADC0.11 CS0.11
C2	P0.6	Multifunction I/O	Yes	P0MAT.6 CNVSTR INT0.6 INT1.6	ADC0.6 CS0.6
C3	P0.1	Multifunction I/O	Yes	P0MAT.1 INT0.1 INT1.1	ADC0.1 CS0.1 AGND
C4	VDD	Supply Power Input			
D1	P1.1	Multifunction I/O	Yes	P1MAT.1	CMP0N.4 CS0.9
D2	P1.4	Multifunction I/O	Yes	P1MAT.4	ADC0.12 CS0.12
D3	RSTb / C2CK	Active-low Reset / C2 Debug Clock			
D4	P2.7 / C2D	Multifunction I/O / C2 Debug Data			

7. CSP16 Package Specifications

7.1 CSP16 Package Dimensions

Note: CSP devices can be handled and soldered using industry standard surface mount assembly techniques. However, because CSP devices are essentially a piece of silicon and are not encapsulated in plastic, they are susceptible to mechanical damage and may be sensitive to light. When CSP packages must be used in an environment exposed to light, it may be necessary to cover the top and sides with an opaque material.

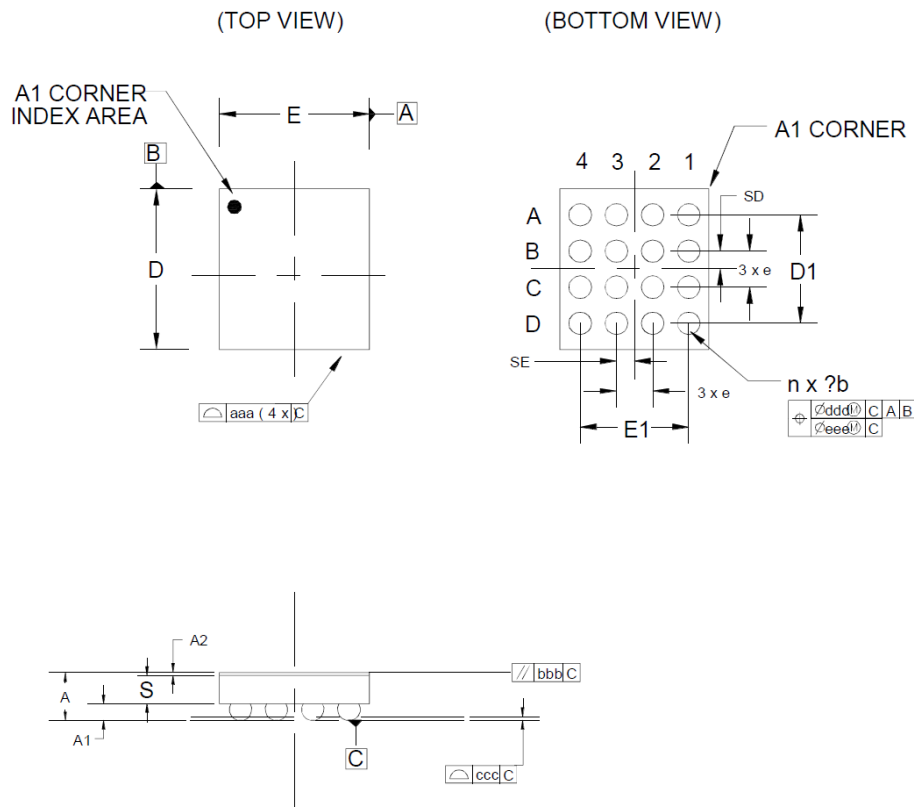

Figure 7.1. CSP16 Package Drawing

Table 7.1. CSP16 Package Dimensions

Dimension	Min	Typ	Max
A	0.491	0.55	0.609
A1	0.17	—	0.23
A2	0.036	0.040	0.044
b	0.23	—	0.29
S	0.3075	0.31	0.3125
D	1.781 BSC		
E	1.659 BSC		
e	0.40 BSC		
D1	1.20 BSC		
E1	1.20 BSC		

Dimension	Min	Typ	Max
SD		0.2	
SE		0.2	
n		16	
aaa		0.03	
bbb		0.06	
ccc		0.05	
ddd		0.015	

Note:

1. All dimensions shown are in millimeters (mm) unless otherwise noted.
2. Dimensioning and Tolerancing per ANSI Y14.5M-1994.
3. Primary datum “C” and seating plane are defined by the spherical crowns of the solder balls.
4. Dimension “b” is measured at the maximum solder bump diameter, parallel to primary datum “C”.
5. Recommended card reflow profile is per the JEDEC/IPC J-STD-020C specification for Small Body Components.

7.2 CSP16 PCB Land Pattern

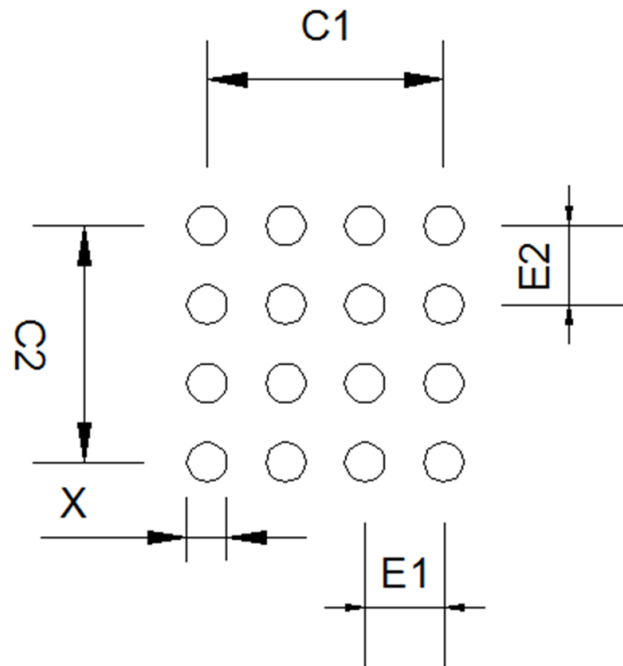

Figure 7.2. CSP16 PCB Land Pattern Drawing

Table 7.2. CSP16 PCB Land Pattern Dimensions

Dimension	Min	Max
X		0.20
C1		1.20
C2		1.20
E1		0.40
E2		0.40

Note:

1. All dimensions shown are in millimeters (mm) unless otherwise noted.
2. Dimensioning and Tolerancing is per the ANSI Y14.5M-1994 specification.
3. This Land Pattern Design is based on the IPC-7351 guidelines.
4. All metal pads are to be non-solder mask defined (NSMD). Clearance between the solder mask and the metal pad is to be 60 μm minimum, all the way around the pad.
5. A stainless steel, laser-cut and electro-polished stencil with trapezoidal walls should be used to assure good solder paste release.
6. The stencil thickness should be 0.075 mm (3 mils).
7. A stencil of square aperture (0.22 x 0.22 mm) is recommended.
8. A No-Clean, Type-3 solder paste is recommended.
9. The recommended card reflow profile is per the JEDEC/IPC J-STD-020 specification for Small Body Components.

7.3 CSP16 Package Marking

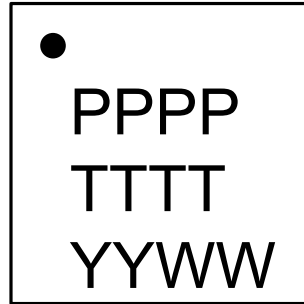

Figure 7.3. CSP16 Package Marking

The package marking consists of:

- PPPP – The part number designation.
- TTTT – A trace or manufacturing code.
- YY – The last 2 digits of the assembly year.
- WW – The 2-digit workweek when the device was assembled.

8. QFN20G Package Specifications

Note: This section includes packaging information for G-grade devices.

8.1 QFN20 Package Dimensions

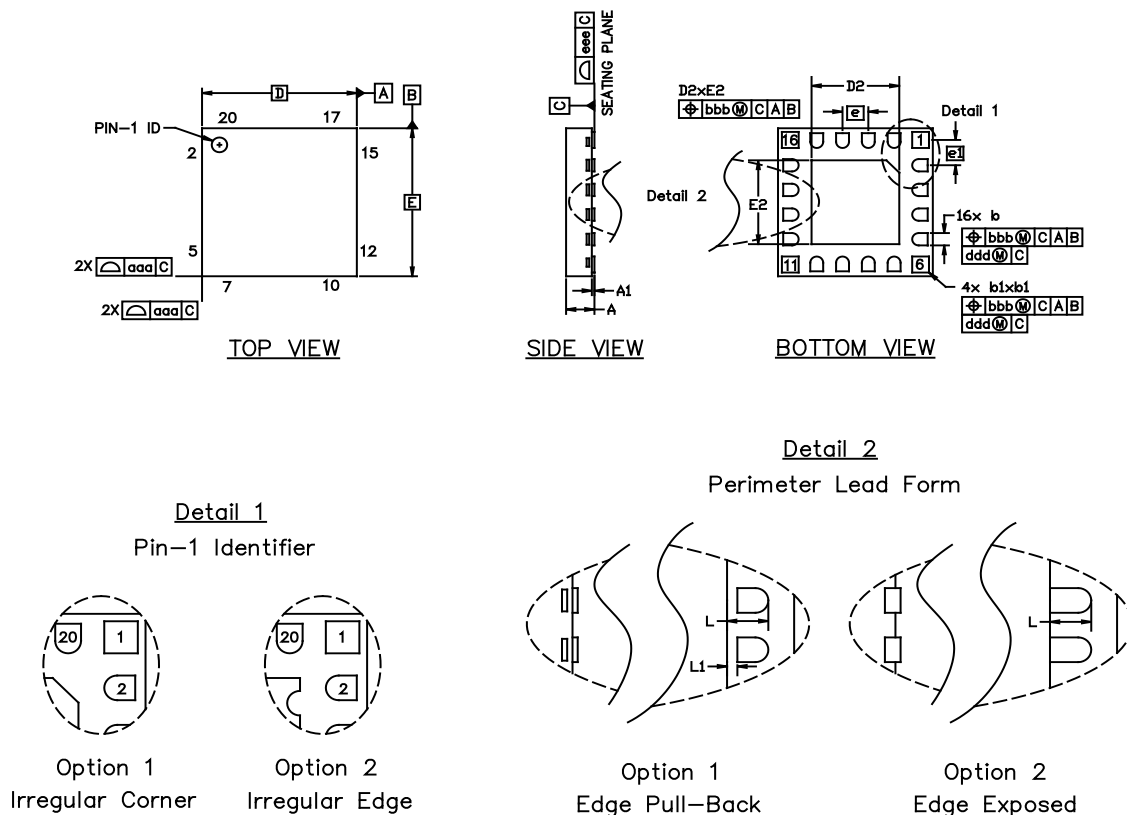

Figure 8.1. QFN20 Package Drawing

Table 8.1. QFN20 Package Dimensions

Dimension	Min	Typ	Max
A	0.50	0.55	0.60
A1	0.00	—	0.05
b	0.20	0.25	0.30
b1	0.275	0.325	0.375
D		3.00 BSC	
D2	1.6	1.70	1.80
e		0.50 BSC	
e1		0.513 BSC	
E		3.00 BSC	
E2	1.60	1.70	1.80
L	0.35	0.40	0.45
L1	0.00	—	0.10
aaa	—	0.10	—
bbb	—	0.10	—

Dimension	Min	Typ	Max
ddd	—	0.05	—
eee	—	—	0.08

Note:

1. All dimensions shown are in millimeters (mm) unless otherwise noted.
2. Dimensioning and Tolerancing per ANSI Y14.5M-1994.
3. This drawing is based upon JEDEC Solid State Product Outline MO-248 but includes custom features which are toleranced per supplier designation.
4. Recommended card reflow profile is per the JEDEC/IPC J-STD-020 specification for Small Body Components.

8.2 QFN20 PCB Land Pattern

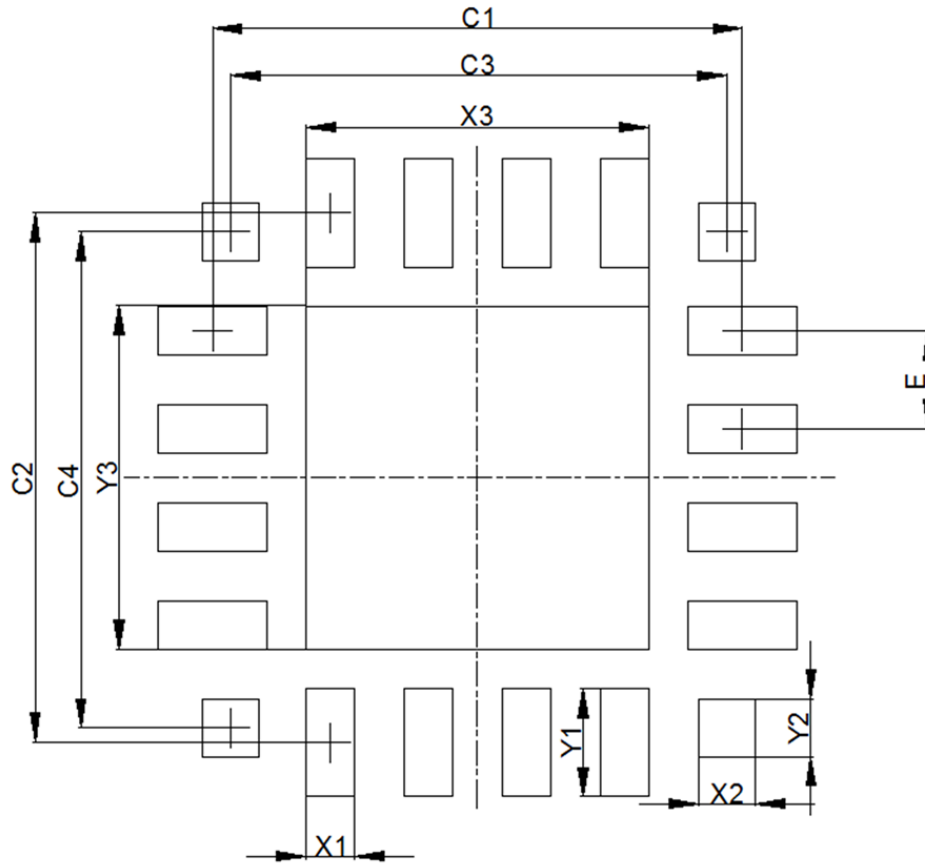

Figure 8.2. QFN20 PCB Land Pattern Drawing

Table 8.2. QFN20 PCB Land Pattern Dimensions

Dimension	Min	Max
C1		2.70
C2		2.70
C3		2.53
C4		2.53
E		0.50 REF
X1	0.20	0.30
X2	0.24	0.34
X3	1.70	1.80
Y1	0.50	0.60
Y2	0.24	0.34
Y3	1.70	1.80

Dimension	Min	Max
<p>Note:</p> <ol style="list-style-type: none"> 1. All dimensions shown are in millimeters (mm) unless otherwise noted. 2. Dimensioning and Tolerancing is per the ANSI Y14.5M-1994 specification. 3. This Land Pattern Design is based on the IPC-7351 guidelines. 4. All metal pads are to be non-solder mask defined (NSMD). Clearance between the solder mask and the metal pad is to be 60 μm minimum, all the way around the pad. 5. A stainless steel, laser-cut and electro-polished stencil with trapezoidal walls should be used to assure good solder paste release. 6. The stencil thickness should be 0.125 mm (5 mils). 7. The ratio of stencil aperture to land pad size should be 1:1 for the perimeter pads. 8. A 2x2 array of 0.75 mm openings on a 0.95 mm pitch should be used for the center pad to assure proper paste volume. 9. A No-Clean, Type-3 solder paste is recommended. 10. The recommended card reflow profile is per the JEDEC/IPC J-STD-020 specification for Small Body Components. 		

8.3 QFN20 Package Marking

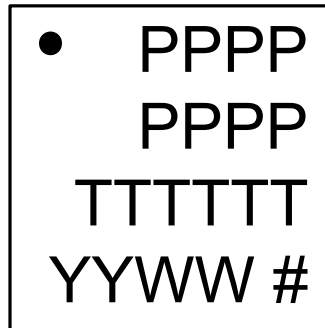

Figure 8.3. QFN20 Package Marking

The package marking consists of:

- P P P P P P P P – The part number designation.
- T T T T T T – A trace or manufacturing code.
- Y Y – The last 2 digits of the assembly year.
- W W – The 2-digit workweek when the device was assembled.
- # – The device revision (A, B, etc.).

Note: Firmware revision is not part of the package marking.

9. QFN20A Package Specifications

Note: This section includes packaging information for A-grade devices.

9.1 QFN20 Package Dimensions

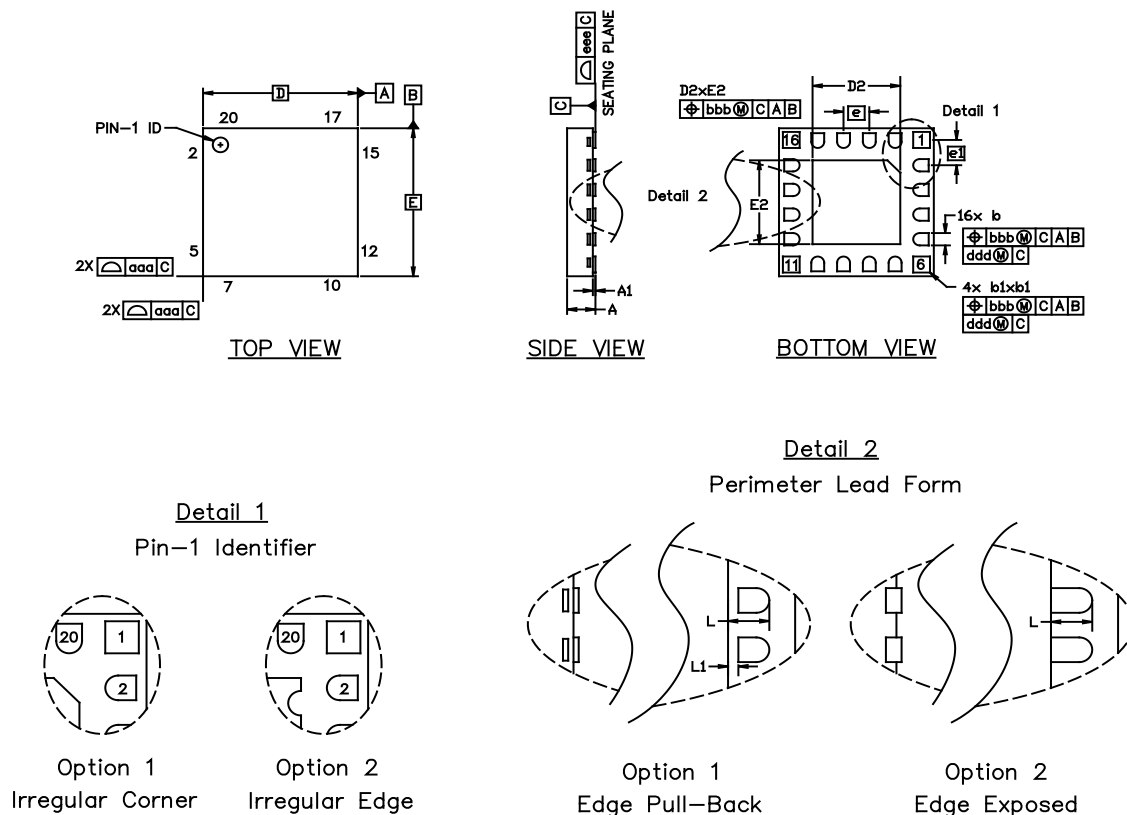

Figure 9.1. QFN20 Package Drawing

Table 9.1. QFN20 Package Dimensions

Dimension	Min	Typ	Max
A	0.70	0.75	0.80
A1	0.00	0.035	0.05
b	0.20	0.25	0.30
b1	0.25	0.30	0.35
D	3.00 BSC		
D2	1.60	1.70	1.80
e	0.50 BSC		
e1	0.513 BSC		
E	3.00 BSC		
E2	1.60	1.70	1.80
L	0.35	0.40	0.45
L1	0.00	—	0.10
aaa	—	0.10	—
bbb	—	0.10	—

Dimension	Min	Typ	Max
ddd	—	0.05	—
eee	—	—	0.08

Note:

1. All dimensions shown are in millimeters (mm) unless otherwise noted.
2. Dimensioning and Tolerancing per ANSI Y14.5M-1994.
3. This drawing is based upon JEDEC Solid State Product Outline MO-248 but includes custom features which are toleranced per supplier designation.
4. Recommended card reflow profile is per the JEDEC/IPC J-STD-020 specification for Small Body Components.

9.2 QFN20 PCB Land Pattern

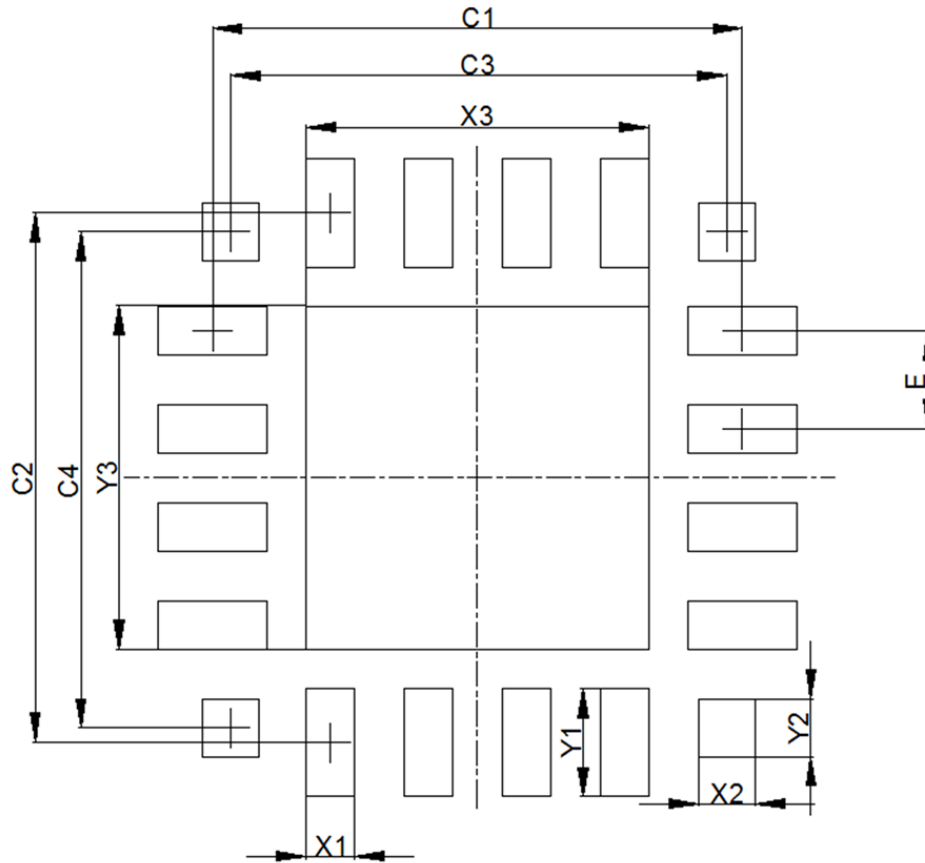

Figure 9.2. QFN20 PCB Land Pattern Drawing

Table 9.2. QFN20 PCB Land Pattern Dimensions

Dimension	Min	Max
C1		2.70
C2		2.70
C3		2.53
C4		2.53
E		0.50 REF
X1	0.20	0.30
X2	0.24	0.34
X3	1.70	1.80
Y1	0.50	0.60
Y2	0.24	0.34
Y3	1.70	1.80

Dimension	Min	Max
<p>Note:</p> <ol style="list-style-type: none"> 1. All dimensions shown are in millimeters (mm) unless otherwise noted. 2. Dimensioning and Tolerancing is per the ANSI Y14.5M-1994 specification. 3. This Land Pattern Design is based on the IPC-7351 guidelines. 4. All metal pads are to be non-solder mask defined (NSMD). Clearance between the solder mask and the metal pad is to be 60 μm minimum, all the way around the pad. 5. A stainless steel, laser-cut and electro-polished stencil with trapezoidal walls should be used to assure good solder paste release. 6. The stencil thickness should be 0.125 mm (5 mils). 7. The ratio of stencil aperture to land pad size should be 1:1 for the perimeter pads. 8. A 2x2 array of 0.75 mm openings on a 0.95 mm pitch should be used for the center pad to assure proper paste volume. 9. A No-Clean, Type-3 solder paste is recommended. 10. The recommended card reflow profile is per the JEDEC/IPC J-STD-020 specification for Small Body Components. 		

9.3 QFN20 Package Marking

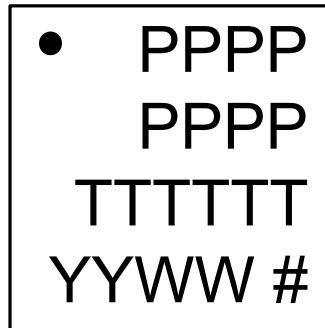

Figure 9.3. QFN20 Package Marking

The package marking consists of:

- P P P P P P P P – The part number designation.
- T T T T T T – A trace or manufacturing code.
- Y Y – The last 2 digits of the assembly year.
- W W – The 2-digit workweek when the device was assembled.
- # – The device revision (A, B, etc.).

Note: Firmware revision is not part of the package marking.

10. QFN24 Package Specifications

10.1 QFN24 Package Dimensions

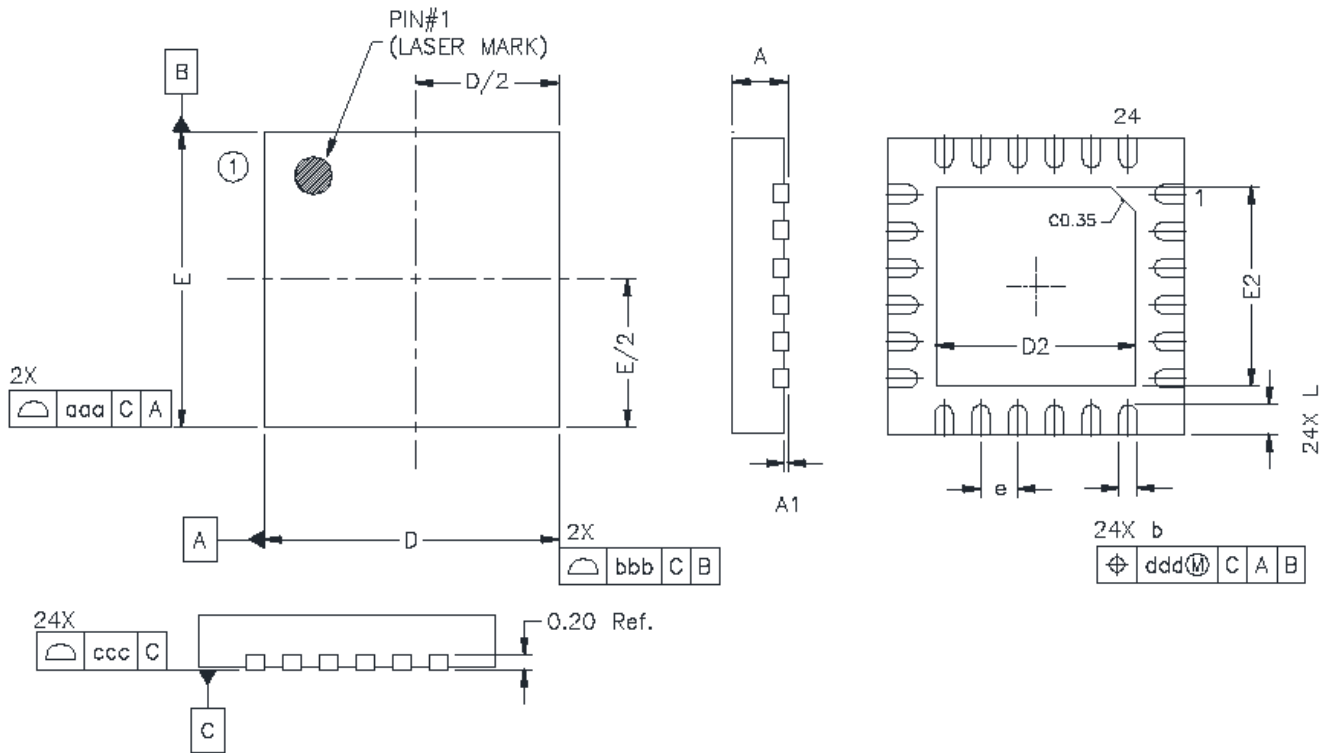

Figure 10.1. QFN24 Package Drawing

Table 10.1. QFN24 Package Dimensions

Dimension	Min	Typ	Max
A	0.70	0.75	0.80
A1	0.00	0.025	0.05
b	0.20	0.25	0.30
D	4.00 BSC		
D2	2.60	2.70	2.80
e	0.50 BSC		
E	4.00 BSC		
E2	2.60	2.70	2.80
L	0.30	0.40	0.50
aaa	0.10		
bbb	0.10		
ccc	0.08		
ddd	0.07		

Dimension	Min	Typ	Max
<p>Note:</p> <ol style="list-style-type: none">1. All dimensions shown are in millimeters (mm) unless otherwise noted.2. Dimensioning and Tolerancing per ANSI Y14.5M-1994.3. This drawing conforms to JEDEC outline MO-220, variation VGGD-8.4. Recommended card reflow profile is per the JEDEC/IPC J-STD-020C specification for Small Body Components.			

10.2 PCB Land Pattern

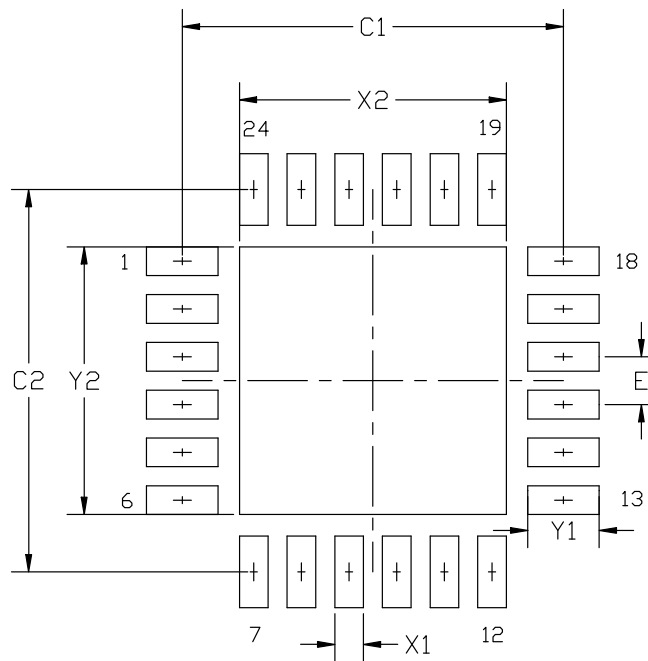

Figure 10.2. PCB Land Pattern Drawing

Table 10.2. PCB Land Pattern Dimensions

Dimension	Min	Max
C1	3.90	4.00
C2	3.90	4.00
E	0.50 BSC	
X1	0.20	0.30
X2	2.70	2.80
Y1	0.65	0.75
Y2	2.70	2.80

Note:

1. All dimensions shown are in millimeters (mm) unless otherwise noted.
2. This Land Pattern Design is based on the IPC-7351 guidelines.
3. All metal pads are to be non-solder mask defined (NSMD). Clearance between the solder mask and the metal pad is to be 60 μm minimum, all the way around the pad.
4. A stainless steel, laser-cut and electro-polished stencil with trapezoidal walls should be used to assure good solder paste release.
5. The stencil thickness should be 0.125 mm (5 mils).
6. The ratio of stencil aperture to land pad size should be 1:1 for all perimeter pads.
7. A 2 x 2 array of 1.10 mm x 1.10 mm openings on 1.30 mm pitch should be used for the center ground pad.
8. A No-Clean, Type-3 solder paste is recommended.
9. The recommended card reflow profile is per the JEDEC/IPC J-STD-020 specification for Small Body Components.

10.3 Package Marking



Figure 10.3. Package Marking

The package marking consists of:

- PPPPPPP – The part number designation.
- TTTTTT – A trace or manufacturing code.
- YY – The last 2 digits of the assembly year.
- WW – The 2-digit workweek when the device was assembled.
- # – The device revision (A, B, etc.).

Note: Firmware revision is not part of the package marking.

11. QSOP24 Package Specifications

11.1 Package Dimensions

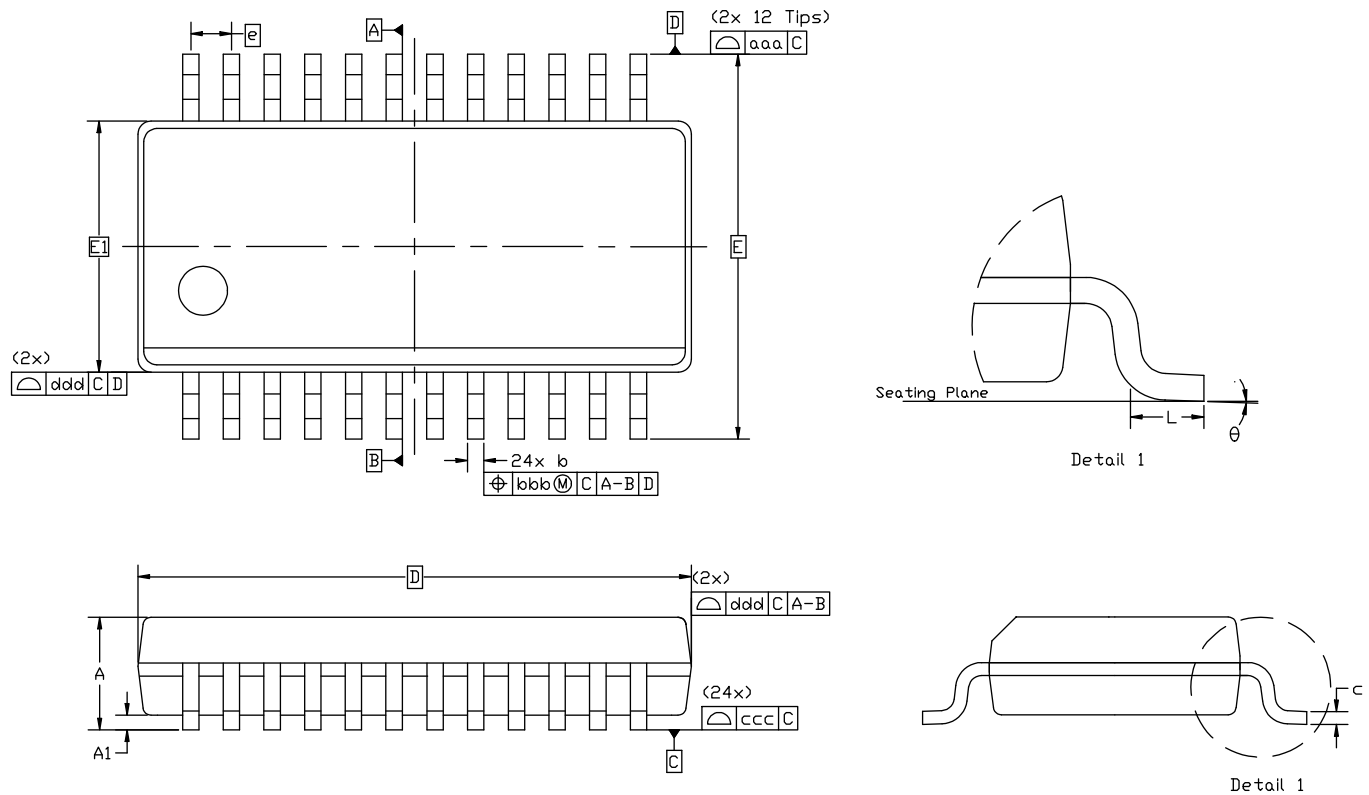

Figure 11.1. Package Drawing

Table 11.1. Package Dimensions

Dimension	Min	Typ	Max
A	—	—	1.75
A1	0.10	—	0.25
b	0.20	—	0.30
c	0.10	—	0.25
D	8.65 BSC		
E	6.00 BSC		
E1	3.90 BSC		
e	0.635 BSC		
L	0.40	—	1.27

Dimension	Min	Typ	Max
theta	0°	—	8°
aaa		0.20	
bbb		0.18	
ccc		0.10	
ddd		0.10	

Note:

1. All dimensions shown are in millimeters (mm) unless otherwise noted.
2. Dimensioning and Tolerancing per ANSI Y14.5M-1994.
3. This drawing conforms to JEDEC outline MO-137, variation AE.
4. Recommended card reflow profile is per the JEDEC/IPC J-STD-020 specification for Small Body Components.

11.2 PCB Land Pattern

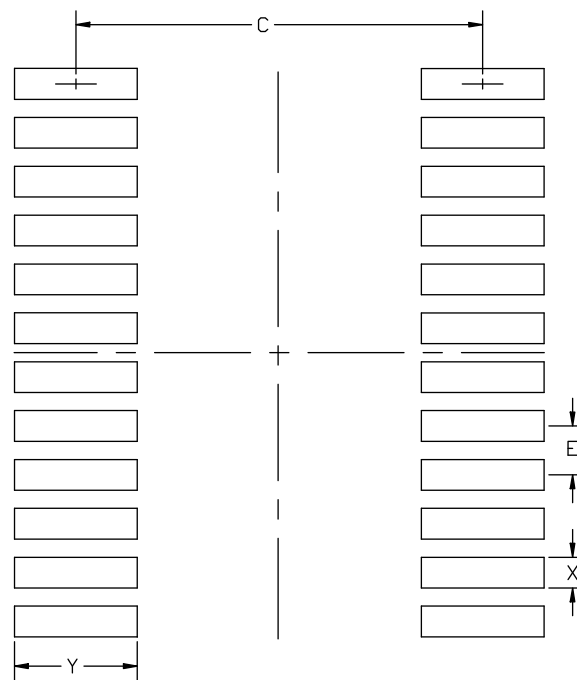

Figure 11.2. PCB Land Pattern Drawing

Table 11.2. PCB Land Pattern Dimensions

Dimension	Min	Max
C	5.20	5.30
E	0.635 BSC	
X	0.30	0.40
Y	1.50	1.60

Note:

1. All dimensions shown are in millimeters (mm) unless otherwise noted.
2. This land pattern design is based on the IPC-7351 guidelines.
3. All metal pads are to be non-solder mask defined (NSMD). Clearance between the solder mask and the metal pad is to be 60 μm minimum, all the way around the pad.
4. A stainless steel, laser-cut and electro-polished stencil with trapezoidal walls should be used to assure good solder paste release.
5. The stencil thickness should be 0.125 mm (5 mils).
6. The ratio of stencil aperture to land pad size should be 1:1 for all perimeter pads.
7. A No-Clean, Type-3 solder paste is recommended.
8. The recommended card reflow profile is per the JEDEC/IPC J-STD-020 specification for Small Body Components.

11.3 Package Marking



Figure 11.3. Package Marking

The package marking consists of:

- P P P P P P P P – The part number designation.
- T T T T T T – A trace or manufacturing code.
- Y Y – The last 2 digits of the assembly year.
- W W – The 2-digit workweek when the device was assembled.
- # – The device revision (A, B, etc.).

12. Revision History

12.1 Revision 1.5

March, 2024

- Noted that all QSOP Package OPNs are EOL.
- Updated QFN24 packaging information.
- Updated Silicon Labs recommendation for code security when using the Bootloader in the [3.10 Bootloader](#) section.

12.2 Revision 1.4

March 13, 2017

Updated A-grade QFN20 packaging information. The G-grade QFN20 and A-grade QFN20 devices now have different packages. Also fixed a typo in the X2 dimension for the QFN20G package.

Updated the language in [1. Feature List](#) to clarify the package offerings for each of the different temperature grades.

Corrected the application note number for *AN124: Pin Sharing Techniques for the C2 Interface* in [5.2 Debug](#).

12.3 Revision 1.3

September 23, 2016

Added A-grade parts.

Added [5.2 Debug](#).

Added bootloader pinout information and a reference to *AN945: EFM8 Factory Bootloader User Guide* in [3.10 Bootloader](#).

Added specifications for [4.1.16 SMBus](#).

Added CRC Calculation Time to [4.1.4 Flash Memory](#).

Added a note linking to the Typical VOH and VOL Performance graphs in [4.1.15 Port I/O](#).

Added the t_{POR} and adjusted the V_{POR} falling specifications in [4.1.3 Reset and Supply Monitor](#).

Added a note to [3.1 Introduction](#) referencing the Reference Manual.

Added a note to [3.2 Power](#) to clarify that entering Sleep may disconnect the active debug session.

Specified that the UART has a 1-byte FIFO in [3.6 Communications and Other Digital Peripherals](#).

12.4 Revision 1.2

Added CSP16 package.

Updated the "C2D / P2.0" pin on the QSOP24 pinout diagram to "C2D / P2.7."

Added crystal oscillator drive current typical values to [Table 4.7 Crystal Oscillator on page 21](#).

Corrected the number of capacitive sense channels for 24- and 20-pin packages in [Table 4.14 Capacitive Sense \(CS0\) on page 27](#).

Corrected E dimension shown in [Figure 8.2 QFN20 PCB Land Pattern Drawing on page 55](#).

Added more information to [3.10 Bootloader](#).

12.5 Revision 1.1

Initial release.

Simplicity Studio

One-click access to MCU and wireless tools, documentation, software, source code libraries & more. Available for Windows, Mac and Linux!



IoT Portfolio
www.silabs.com/IoT



SW/HW
www.silabs.com/simplicity



Quality
www.silabs.com/quality



Support & Community
www.silabs.com/community

Disclaimer

Silicon Labs intends to provide customers with the latest, accurate, and in-depth documentation of all peripherals and modules available for system and software implementers using or intending to use the Silicon Labs products. Characterization data, available modules and peripherals, memory sizes and memory addresses refer to each specific device, and "Typical" parameters provided can and do vary in different applications. Application examples described herein are for illustrative purposes only. Silicon Labs reserves the right to make changes without further notice to the product information, specifications, and descriptions herein, and does not give warranties as to the accuracy or completeness of the included information. Without prior notification, Silicon Labs may update product firmware during the manufacturing process for security or reliability reasons. Such changes will not alter the specifications or the performance of the product. Silicon Labs shall have no liability for the consequences of use of the information supplied in this document. This document does not imply or expressly grant any license to design or fabricate any integrated circuits. The products are not designed or authorized to be used within any FDA Class III devices, applications for which FDA premarket approval is required or Life Support Systems without the specific written consent of Silicon Labs. A "Life Support System" is any product or system intended to support or sustain life and/or health, which, if it fails, can be reasonably expected to result in significant personal injury or death. Silicon Labs products are not designed or authorized for military applications. Silicon Labs products shall under no circumstances be used in weapons of mass destruction including (but not limited to) nuclear, biological or chemical weapons, or missiles capable of delivering such weapons. Silicon Labs disclaims all express and implied warranties and shall not be responsible or liable for any injuries or damages related to use of a Silicon Labs product in such unauthorized applications.

Note: This content may contain offensive terminology that is now obsolete. Silicon Labs is replacing these terms with inclusive language wherever possible. For more information, visit www.silabs.com/about-us/inclusive-lexicon-project

Trademark Information

Silicon Laboratories Inc.[®], Silicon Laboratories[®], Silicon Labs[®], SiLabs[®] and the Silicon Labs logo[®], Bluegiga[®], Bluegiga Logo[®], EFM[®], EFM32[®], EFR, Ember[®], Energy Micro, Energy Micro logo and combinations thereof, "the world's most energy friendly microcontrollers", Redpine Signals[®], WiSeConnect, n-Link, ThreadArch[®], EZLink[®], EZRadio[®], EZRadioPRO[®], Gecko[®], Gecko OS, Gecko OS Studio, Precision32[®], Simplicity Studio[®], Telegesis, the Telegesis Logo[®], USBXpress[®], Zentri, the Zentri logo and Zentri DMS, Z-Wave[®], and others are trademarks or registered trademarks of Silicon Labs. ARM, CORTEX, Cortex-M3 and THUMB are trademarks or registered trademarks of ARM Holdings. Keil is a registered trademark of ARM Limited. Wi-Fi is a registered trademark of the Wi-Fi Alliance. All other products or brand names mentioned herein are trademarks of their respective holders.





Silicon Laboratories Inc.
400 West Cesar Chavez
Austin, TX 78701
USA

www.silabs.com

Looking for pricing, stock, or lifecycle information?

Click below to explore more details on WIN SOURCE:

-  [View EFM8SB10F8A-A-QFN20 on WIN SOURCE](#)
-  [Silicon Labs](#) Information

Optimize Your Supply Chain with WIN SOURCE Solutions

-  Global Sourcing Solution
-  Obsolete Management
-  Cost Control Management
-  Shortage Management
-  Alternative Solution
-  Excess Inventory Management