



**THE DATASHEET OF
SM470R1B1MHFQS**



SM470R1B1M-HT 16-/32-Bit RISC Flash Microcontroller

1 Device Overview

1.1 Features

- High-Performance Static CMOS Technology
 - SM470R1x 16-/32-Bit RISC Core (ARM7TDMI™)
 - 60-MHz System Clock (Pipeline Mode)
 - Independent 16-/32-Bit Instruction Set
 - Open Architecture With Third-Party Support
 - Built-In Debug Module
 - Integrated Memory
 - 1MB Program Flash
 - Two Banks With 16 Contiguous Sectors
 - 64KB Static RAM (SRAM)
 - Memory Security Module (MSM)
 - JTAG Security Module
 - Operating Features
 - Low-Power Modes: STANDBY and HALT
 - Industrial Temperature Range
 - 470+ System Module
 - 32-Bit Address Space Decoding
 - Bus Supervision for Memory/Peripherals
 - Digital Watchdog (DWD) Timer
 - Analog Watchdog (AWD) Timer
 - Enhanced Real-Time Interrupt (RTI)
 - Interrupt Expansion Module (IEM)
 - System Integrity and Failure Detection
 - ICE Breaker
 - Direct Memory Access (DMA) Controller
 - 32 Control Packets and 16 Channels
 - Zero-Pin Phase-Locked Loop (ZPLL)-Based Clock Module With Prescaler
 - Multiply-by-4 or -8 Internal ZPLL Option
 - ZPLL Bypass Mode
 - Twelve Communication Interfaces:
 - Two Serial Peripheral Interfaces (SPIs)
 - 255 Programmable Baud Rates
 - Three Serial Communication Interfaces (SCIs)
 - 2²⁴ Selectable Baud Rates
 - Asynchronous/Isosynchronous Modes
 - Two High-End CAN Controllers (HECC)
 - 32-Mailbox Capacity
 - Fully Compliant With CAN Protocol, Version 2.0B
 - Five Inter-Integrated Circuit (I²C) Modules
 - Multi-Master and Slave Interfaces
 - Up to 400 Kbps (Fast Mode)
 - 7- and 10-Bit Address Capability
 - High-End Timer Lite (HET)
 - 12 Programmable I/O Channels:
 - 12 High-Resolution Pins
 - High-Resolution Share Feature (XOR)
 - High-End Timer RAM
 - 64-Instruction Capacity
 - External Clock Prescale (ECP) Module
 - Programmable Low-Frequency External Clock (CLK)
 - 12-Channel, 10-Bit Multi-Buffered ADC (MibADC)
 - 64-Word FIFO Buffer
 - Single- or Continuous-Conversion Modes
 - 1.55- μ s Minimum Sample and Conversion Time
 - Calibration Mode and Self-Test Features
 - Flexible Interrupt Handling
 - Expansion Bus Module (EBM)
 - Supports 8- and 16-Bit Expansion Bus Memory Interface Mappings
 - 42 I/O Expansion Bus Pins
 - 46 Dedicated General-Purpose I/O (GIO) Pins and 47 Additional Peripheral I/Os
 - Sixteen External Interrupts
 - On-Chip Scan-Base Emulation Logic, IEEE Standard 1149.1 ⁽¹⁾ (JTAG) Test-Access Port
 - Available in KGD, HFQ, HKP, and PGE Packages
- (1) The test-access port is compatible with the IEEE Standard 1149.1-1990, IEEE Standard Test-Access Port and Boundary Scan Architecture specification. Boundary scan is not supported on this device.



1.2 Applications

- Supports Extreme Temperature Applications:
 - Controlled Baseline
 - One Assembly/Test Site
 - One Fabrication Site
 - Available in Extreme (–55°C to 220°C) Temperature Range ⁽²⁾
 - Extended Product Life Cycle
 - Extended Product-Change Notification
 - Product Traceability
 - Texas Instruments' high temperature products use highly optimized silicon (die) solutions with design and process enhancements to maximize performance over extended temperatures.

(2) Custom temperature ranges available

1.3 Description

The SM470R1B1M ⁽³⁾ devices are members of the Texas Instruments SM470R1x family of general-purpose 16-/32-bit reduced instruction set computer (RISC) microcontrollers. The B1M microcontroller offers high performance using the high-speed ARM7TDMI 16-/32-bit RISC central processing unit (CPU), resulting in a high instruction throughput while maintaining greater code efficiency. The ARM7TDMI 16-/32-bit RISC CPU views memory as a linear collection of bytes numbered upwards from zero. The SM470R1B1M uses the big-endian format where the most significant byte of a word is stored at the lowest numbered byte and the least significant byte of a word is stored at the highest numbered byte.

High-end embedded control applications demand more performance from their controllers while maintaining low costs. The B1M RISC core architecture offers solutions to these performance and cost demands while maintaining low power consumption.

The B1M devices contain the following:

- ARM7TDMI 16-/32-bit RISC CPU
- SM470R1x system module (SYS) with 470+ enhancements
- 1MB flash
- 64KB SRAM
- ZPLL clock module
- DWD timer
- AWD timer
- Enhanced RTI module
- IEM
- MSM
- JTAG security module
- Two SPI modules
- Three SCI modules
- Two HECC
- Five I²C modules
- 10-bit MibADC, with 12 input channels
- HET controlling 12 I/Os
- ECP

(3) Throughout the remainder of this document, the SM470R1B1M will be referred to as either the full device name or as B1M.

- EBM
- Up to 93 I/O pins

The functions performed by the 470+ system module (SYS) include:

- Address decoding
- Memory protection
- Memory and peripherals bus supervision
- Reset and abort exception management
- Prioritization for all internal interrupt sources
- Device clock control
- Parallel signature analysis (PSA)

The enhanced RTI module on the B1M has the option to be driven by the oscillator clock. The DWD is a 25-bit resettable decrementing counter that provides a system reset when the watchdog counter expires. This data sheet includes device-specific information such as memory and peripheral select assignment, interrupt priority, and a device memory map. For a more detailed functional description of the SYS module, see the *TMS470R1x System Module Reference Guide* ([SPNU189](#)).

The B1M memory includes general-purpose SRAM supporting single-cycle read/write accesses in byte, half-word, and word modes.

The flash memory on this device is a nonvolatile, electrically erasable, and programmable memory implemented with a 32-bit-wide data bus interface. The flash operates with a system clock frequency of up to 24 MHz or 30 MHz, depending on the input voltage. When in pipeline mode, the flash operates with a system clock frequency of up to 48 MHz or 60 MHz, depending on the input voltage. For more detailed information on the flash, see [Section 8.2.1.4](#).

The MSM and the JTAG security module prevent unauthorized access and visibility to on-chip memory, thereby preventing reverse engineering or manipulation of proprietary code.

The B1M device has twelve communication interfaces: two SPIs, three SCIs, two HECCs, and five I²Cs. The SPI provides a convenient method of serial interaction for high-speed communications between similar shift-register type devices. The SCI is a full-duplex, serial I/O interface intended for asynchronous communication between the CPU and other peripherals using the standard non-return-to-zero (NRZ) format. The HECC uses a serial, multimaster communication protocol that efficiently supports distributed realtime control with robust communication rates of up to 1 Mbps. These CAN peripherals are ideal for applications operating in noisy and harsh environments (for example, industrial fields) that require reliable serial communication or multiplexed wiring. The I²C module is a multimaster communication module providing an interface between the B1M microcontroller and an I²C-compatible device through the I²C serial bus. The I²C supports both 100 Kbps and 400 Kbps speeds. For more detailed functional information on the SPI, SCI, and CAN peripherals, see the specific reference guides ([SPNU195](#), [SPNU196](#), and [SPNU197](#)). For more detailed functional information on the I²C, see the *TMS470R1x Inter-Integrated Circuit (I²C) Reference Guide* ([SPNU223](#)).

The HET is an advanced intelligent timer that provides sophisticated timing functions for realtime applications. The timer is software-controlled, using a reduced instruction set, with a specialized timer micromachine and an attached I/O port. The HET can be used for compare, capture, or general-purpose I/O. It is especially well-suited for applications requiring multiple sensor information and drive actuators with complex and accurate time pulses. The HET used in this device is the high-end timer lite. It has fewer I/Os than the usual 32 in a standard HET. For more detailed functional information on the HET, see the *TMS470R1x High-End Timer (HET) Reference Guide* ([SPNU199](#)).

The B1M HET peripheral contains the XOR-share feature. This feature allows two adjacent HET high-resolution channels to be XORed together, making it possible to output smaller pulses than a standard HET. For more detailed information on the HET XOR-share feature, see the *TMS470R1x High-End Timer (HET) Reference Guide* ([SPNU199](#)).

The B1M device has one 10-bit-resolution, sample-and-hold MibADC. Each of the MibADC channels can be converted individually or can be grouped by software for sequential conversion sequences. There are three separate groupings, two of which can be triggered by an external event. Each sequence can be converted once when triggered or configured for continuous conversion mode. For more detailed functional information on the MibADC, see the *TMS470R1x Multi-Buffered Analog-to-Digital Converter (MibADC) Reference Guide* ([SPNU206](#)).

The ZPLL clock module contains a phase-locked loop, a clock-monitor circuit, a clock-enable circuit, and a prescaler (with prescale values of 1 to 8). The function of the ZPLL is to multiply the external frequency reference to a higher frequency for internal use. The ZPLL provides ACLK to the system (SYS) module. The SYS module subsequently provides system clock (SYSCLK), realtime interrupt clock (RTICK), CPU clock (MCLK), and peripheral interface clock (ICLK) to all other B1M device modules. For more detailed functional information on the ZPLL, see the *TMS470R1x Zero-Pin Phase-Locked Loop (ZPLL) Clock Module Reference Guide* ([SPNU212](#)).

NOTE

ACLK should not be confused with the MibADC internal clock, ADCLK. ACLK is the continuous system clock from an external resonator/crystal reference.

The EBM is a standalone module that supports the multiplexing of the GIO functions and the expansion bus interface. For more information on the EBM, see the *TMS470R1x Expansion Bus Module (EBM) Reference Guide* ([SPNU222](#)).

The B1M device also has an external clock prescaler (ECP) module that when enabled, outputs a continuous external clock (ECLK) on a specified GIO pin. The ECLK frequency is a user-programmable ratio of the peripheral interface clock (ICLK) frequency. For more detailed functional information on the ECP, see the *TMS470R1x External Clock Prescaler (ECP) Reference Guide* ([SPNU202](#)).

Table 1-1. Device Information⁽¹⁾

PART NUMBER	PACKAGE	T _A
SM470R1B1M-HT	KGD (0)	-55°C to 220°C
	CFP (TBAR) (84)	
	CFP (84)	
	LQFP (144)	-55°C to 150°C

(1) For more information, see Section 10, Mechanical Packaging and Orderable Information.

1.4 Functional Block Diagram

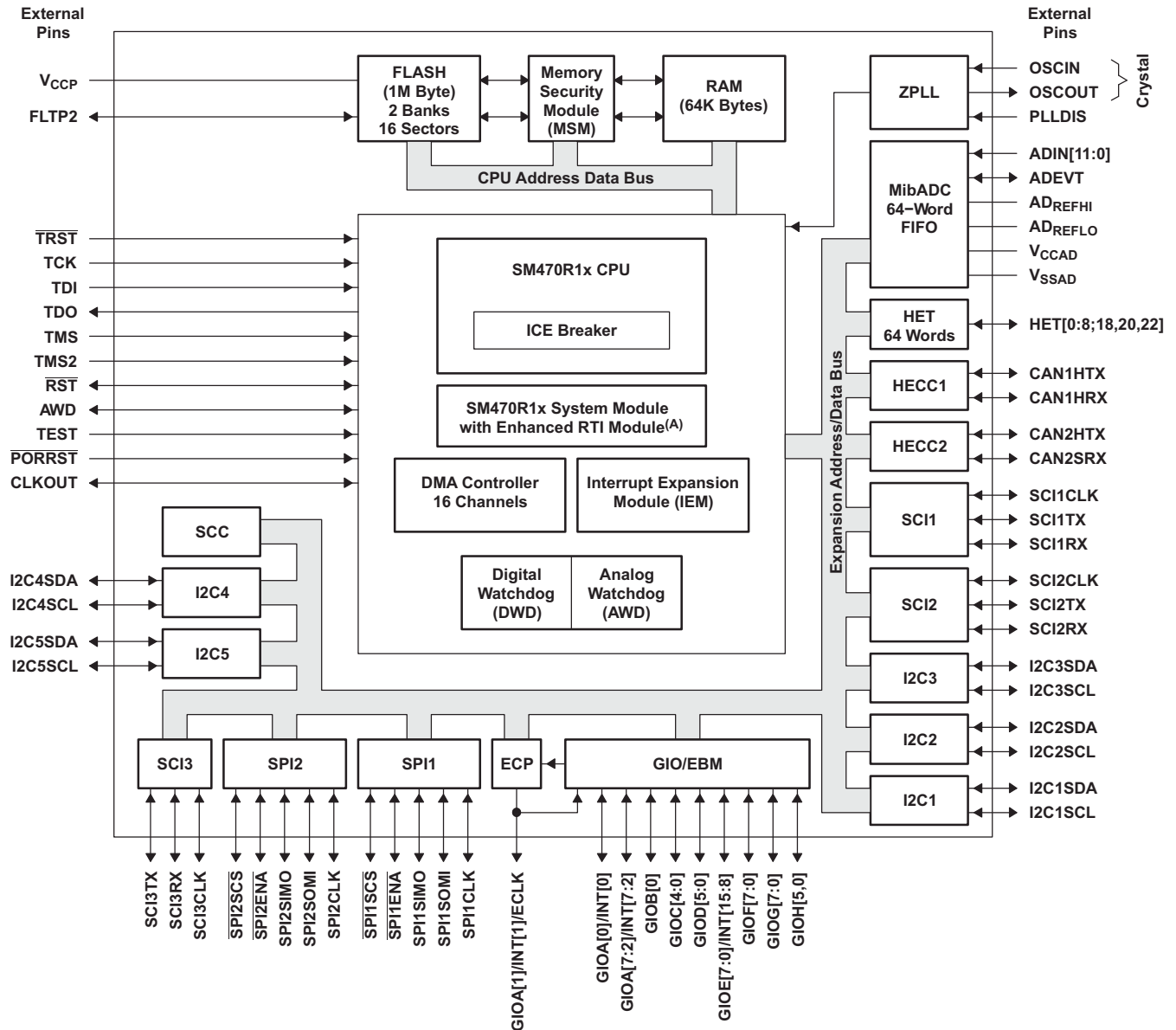

The enhanced RTI module is the system module with two extra bits to disable the ZPLL while in STANDBY mode.

Table of Contents

1	Device Overview	1	6.13	SPI Slave Mode Timing Parameters.....	42
1.1	Features	1	6.14	SCIN Isosynchronous Mode Timings - Internal Clock	45
1.2	Applications.....	2	6.15	SCIN Isosynchronous Mode Timings - External Clock	46
1.3	Description.....	2	6.16	I ² C Timing	47
1.4	Functional Block Diagram	5	6.17	Standard Can Controller (SCC) Mode Timings	48
2	Revision History	7	6.18	Expansion Bus Module Timing.....	49
3	Device Characteristics	9	6.19	Multi-Buffered A-to-D Converter (MibADC)	51
4	Bare Die	10	7	Parameter Measurement Information	55
4.1	Bare Die Information	10	7.1	External Reference Resonator/Crystal Oscillator Clock Option	55
5	Pin Configuration and Functions	15	8	Detailed Description	56
5.1	Features	17	8.1	Overview	56
5.2	Pin Functions (HFQ/HKP Package).....	18	8.2	Memory.....	61
5.3	Pin Functions (PGE Package)	23	9	Device and Documentation Support	68
6	Specifications	30	9.1	Device Support	68
6.1	Absolute Maximum Ratings	30	9.2	Development Support	69
6.2	ESD Ratings	30	9.3	Device Nomenclature	69
6.3	Recommended Operating Conditions	30	9.4	Documentation Support	71
6.4	Electrical Characteristics	31	9.5	Community Resources	71
6.5	Thermal Characteristics	32	9.6	Trademarks.....	71
6.6	ZPLL and Clock Specifications	34	9.7	Electrostatic Discharge Caution.....	72
6.7	R ST and P ^{ORRST} Timings	36	9.8	Glossary	72
6.8	JTAG Scan Interface Timing	37	10	Mechanical Packaging and Orderable Information	73
6.9	Output Timings	38	10.1	Packaging Information	73
6.10	Input Timings.....	39			
6.11	Flash Timings	39			
6.12	SPI Master Mode Timing Parameters	40			

2 Revision History

NOTE: Page numbers for previous revisions may differ from page numbers in the current version.

Changes from Revision H (September 2013) to Revision I	Page
<ul style="list-style-type: none">Added <i>ESD Ratings</i> table, <i>Detailed Description</i> section, <i>Device and Documentation Support</i> section, and <i>Mechanical, Packaging, and Orderable Information</i> section	1
<ul style="list-style-type: none">Updated I_{CC} standby mode maximum from 1.3 mA to 28 mA	32

Changes from Revision G (July 2013) to Revision H**Page**

-
- Changed temperature range condition on *Electrical Characteristics* table [31](#)
 - Added *Thermal Information* table [32](#)
-

3 Device Characteristics

CHARACTERISTICS ⁽¹⁾	DEVICE DESCRIPTION SM470R1B1M	COMMENTS
MEMORY		
For the number of memory selects on this device, see Table 8-5, SM470R1B1M Memory Selection Assignment .		
INTERNAL MEMORY	Pipeline/non-pipeline 1MB flash 64KB SRAM MSM JTAG security module	Flash is pipeline-capable. The B1M RAM is implemented in one 64K array selected by two memory-select signals (see Table 8-5, SM470R1B1M Memory Selection Assignment).
PERIPHERALS		
For the device-specific interrupt priority configurations, see Table 8-2, Interrupt Priority . And for the 1K peripheral address ranges and their peripheral selects, see Table 8-7, B1M Peripherals, System Module, and Flash Base Addresses .		
CLOCK	ZPLL	Zero-pin PLL has no external loop filter pins.
Expansion bus	EBM	Expansion bus module with 42 pins. Supports 8- and 16-bit memories. See Table 8-3 for details.
GENERAL-PURPOSE I/Os	46 I/O	Port A has 8 external pins. Port B has only 1 external pin. Port C has 5 external pins. Port D has 6 external pins. Ports E, F, and G each have 8 external pins. Port H has 2 external pins.
ECP	Yes	
SCI	3 (3 pin)	
CAN (HECC and/or SCC)	2 HECC	Two HECC
SPI (5-pin, 4-pin, or 3-pin)	2 (5 pin)	
I ² C	5	
HET with XOR share	12 I/O	The high-resolution (HR) SHARE feature allows even-numbered HR pins to share the next higher odd-numbered HR pin structures. This HR sharing is independent of whether or not the odd pin is available externally. If an odd pin is available externally and <i>shared</i> , then the odd pin can only be used as a general-purpose I/O. For more information on HR SHARE, see the <i>TMS470R1x High-End Timer (HET) Reference Guide</i> (SPNU199).
HET RAM	64-instruction capacity	
MibADC	10-bit, 12-channel 64-word FIFO	Both the logic and registers for a full 16-channel MibADC are present.
CORE VOLTAGE	1.8 V	
I/O VOLTAGE	3.3 V	
PINS	84 or 144	
PACKAGES	HFQ, HKP, or PGE	

(1) This table identifies all the characteristics of the B1M device except the SYSTEM and CPU, which are generic.

4 Bare Die

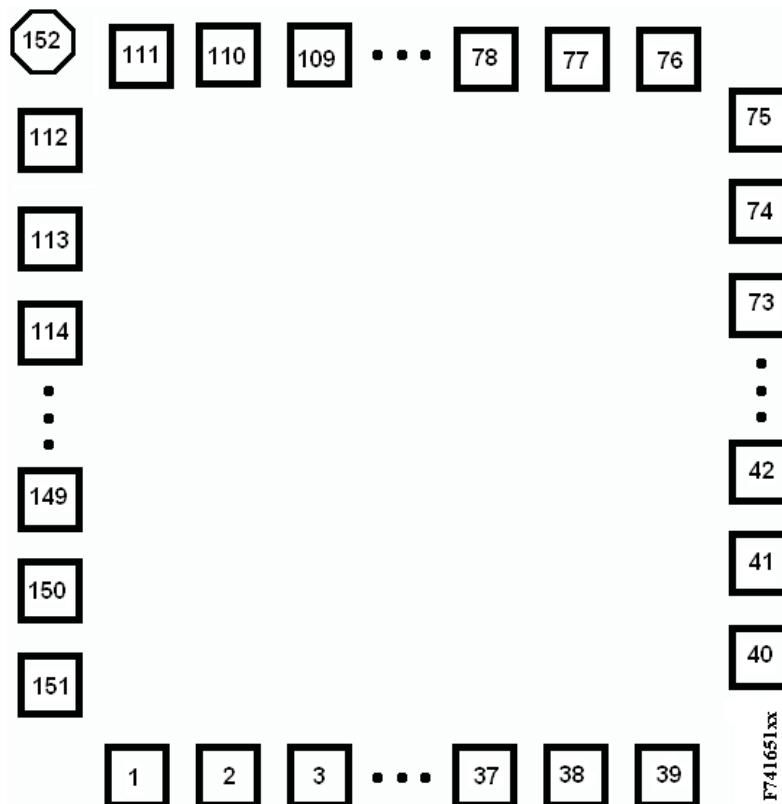

4.1 Bare Die Information

DIE SIZE	DIE PAD SIZE	DIE PAD COORDINATES ⁽¹⁾	DIE THICKNESS	DIE PAD COMPOSITION	BACKSIDE FINISH	BACKSIDE POTENTIAL
208.858 × 211.890 mils/ 5304.99 × 5382.01 μm	65.1 × 65.1 (μm)	See Table 4-1	11 mils	AlCu	Silicon with backgrind	Ground

(1) Pads 12, 22, 26, 136, 143, 146, 149 and 152 are test pads, no connections required. It is highly recommended to leave them open.

Table 4-1. Bond Pad Coordinates

PAD NO.	BOND PAD COORDINATES (μm)				PAD SIZE (μm)	
	X MIN	Y MIN	X MAX	Y MAX	X	Y
1	178.955	10.08	244.055	75.18	65.1	65.1
2	368.2	10.08	433.3	75.18	65.1	65.1
3	557.445	10.08	622.545	75.18	65.1	65.1
4	664.335	10.08	729.435	75.18	65.1	65.1
5	853.58	10.08	918.68	75.18	65.1	65.1
6	1042.825	10.08	1107.925	75.18	65.1	65.1
7	1149.715	10.08	1214.815	75.18	65.1	65.1
8	1338.96	10.08	1404.06	75.18	65.1	65.1
9	1445.85	10.08	1510.95	75.18	65.1	65.1
10	1552.74	10.08	1617.84	75.18	65.1	65.1
11	1659.63	10.08	1724.73	75.18	65.1	65.1
12	1766.52	10.08	1831.62	75.18	65.1	65.1
13	1866.2	10.08	1931.3	75.18	65.1	65.1
14	1965.88	10.08	2030.98	75.18	65.1	65.1
15	2065.56	10.08	2130.66	75.18	65.1	65.1
16	2165.24	10.08	2230.34	75.18	65.1	65.1
17	2272.13	10.08	2337.23	75.18	65.1	65.1
18	2396.1	10.08	2461.2	75.18	65.1	65.1
19	2520.07	10.08	2585.17	75.18	65.1	65.1
20	2626.96	10.08	2692.06	75.18	65.1	65.1
21	2733.85	10.08	2798.95	75.18	65.1	65.1
22	2840.74	10.08	2905.84	75.18	65.1	65.1
23	2947.63	10.08	3012.73	75.18	65.1	65.1
24	3054.52	10.08	3119.62	75.18	65.1	65.1
25	3243.765	10.08	3308.865	75.18	65.1	65.1
26	3350.655	10.08	3415.755	75.18	65.1	65.1
27	3539.9	10.08	3605	75.18	65.1	65.1
28	3646.79	10.08	3711.89	75.18	65.1	65.1
29	3746.47	10.08	3811.57	75.18	65.1	65.1
30	3846.15	10.08	3911.25	75.18	65.1	65.1
31	3953.04	10.08	4018.14	75.18	65.1	65.1
32	4142.285	10.08	4207.385	75.18	65.1	65.1
33	4331.53	10.08	4396.63	75.18	65.1	65.1
34	4431.21	10.08	4496.31	75.18	65.1	65.1
35	4530.89	10.08	4595.99	75.18	65.1	65.1
36	4630.57	10.08	4695.67	75.18	65.1	65.1
37	4730.25	10.08	4795.35	75.18	65.1	65.1
38	4829.93	10.08	4895.03	75.18	65.1	65.1
39	4936.82	10.08	5001.92	75.18	65.1	65.1
40	5150.04	178.955	5215.14	244.055	65.1	65.1
41	5150.04	368.2	5215.14	433.3	65.1	65.1
42	5150.04	557.445	5215.14	622.545	65.1	65.1
43	5150.04	666.26	5215.14	731.36	65.1	65.1
44	5150.04	855.505	5215.14	920.605	65.1	65.1
45	5150.04	1044.75	5215.14	1109.85	65.1	65.1
46	5150.04	1153.565	5215.14	1218.665	65.1	65.1

Table 4-1. Bond Pad Coordinates (continued)

PAD NO.	BOND PAD COORDINATES (μm)				PAD SIZE (μm)	
	X MIN	Y MIN	X MAX	Y MAX	X	Y
47	5150.04	1262.38	5215.14	1327.48	65.1	65.1
48	5150.04	1371.195	5215.14	1436.295	65.1	65.1
49	5150.04	1480.01	5215.14	1545.11	65.1	65.1
50	5150.04	1669.255	5215.14	1734.355	65.1	65.1
51	5150.04	1778.07	5215.14	1843.17	65.1	65.1
52	5150.04	1886.885	5215.14	1951.985	65.1	65.1
53	5150.04	1995.7	5215.14	2060.8	65.1	65.1
54	5150.04	2184.945	5215.14	2250.045	65.1	65.1
55	5150.04	2293.76	5215.14	2358.86	65.1	65.1
56	5150.04	2402.575	5215.14	2467.675	65.1	65.1
57	5150.04	2511.39	5215.14	2576.49	65.1	65.1
58	5150.04	2700.635	5215.14	2765.735	65.1	65.1
59	5150.04	2809.45	5215.14	2874.55	65.1	65.1
60	5150.04	2998.695	5215.14	3063.795	65.1	65.1
61	5150.04	3187.94	5215.14	3253.04	65.1	65.1
62	5150.04	3296.755	5215.14	3361.855	65.1	65.1
63	5150.04	3486	5215.14	3551.1	65.1	65.1
64	5150.04	3675.245	5215.14	3740.345	65.1	65.1
65	5150.04	3784.06	5215.14	3849.16	65.1	65.1
66	5150.04	3973.305	5215.14	4038.405	65.1	65.1
67	5150.04	4082.12	5215.14	4147.22	65.1	65.1
68	5150.04	4190.935	5215.14	4256.035	65.1	65.1
69	5150.04	4299.75	5215.14	4364.85	65.1	65.1
70	5150.04	4408.565	5215.14	4473.665	65.1	65.1
71	5150.04	4517.38	5215.14	4582.48	65.1	65.1
72	5150.04	4626.195	5215.14	4691.295	65.1	65.1
73	5150.04	4735.01	5215.14	4800.11	65.1	65.1
74	5150.04	4843.825	5215.14	4908.925	65.1	65.1
75	5150.04	4952.64	5215.14	5017.74	65.1	65.1
76	4981.165	5148.85	5046.265	5213.95	65.1	65.1
77	4862.935	5148.85	4928.035	5213.95	65.1	65.1
78	4738.965	5148.85	4804.065	5213.95	65.1	65.1
79	4614.995	5148.85	4680.095	5213.95	65.1	65.1
80	4496.765	5148.85	4561.865	5213.95	65.1	65.1
81	4378.535	5148.85	4443.635	5213.95	65.1	65.1
82	4189.29	5148.85	4254.39	5213.95	65.1	65.1
83	4000.045	5148.85	4065.145	5213.95	65.1	65.1
84	3881.815	5148.85	3946.915	5213.95	65.1	65.1
85	3757.845	5148.85	3822.945	5213.95	65.1	65.1
86	3639.615	5148.85	3704.715	5213.95	65.1	65.1
87	3450.37	5148.85	3515.47	5213.95	65.1	65.1
88	3332.14	5148.85	3397.24	5213.95	65.1	65.1
89	3213.91	5148.85	3279.01	5213.95	65.1	65.1
90	3095.68	5148.85	3160.78	5213.95	65.1	65.1
91	2906.435	5148.85	2971.535	5213.95	65.1	65.1
92	2717.19	5148.85	2782.29	5213.95	65.1	65.1

Table 4-1. Bond Pad Coordinates (continued)

PAD NO.	BOND PAD COORDINATES (µm)				PAD SIZE (µm)	
	X MIN	Y MIN	X MAX	Y MAX	X	Y
93	2598.96	5148.85	2664.06	5213.95	65.1	65.1
94	2480.73	5148.85	2545.83	5213.95	65.1	65.1
95	2362.5	5148.85	2427.6	5213.95	65.1	65.1
96	2244.27	5148.85	2309.37	5213.95	65.1	65.1
97	2126.04	5148.85	2191.14	5213.95	65.1	65.1
98	1936.795	5148.85	2001.895	5213.95	65.1	65.1
99	1747.55	5148.85	1812.65	5213.95	65.1	65.1
100	1629.32	5148.85	1694.42	5213.95	65.1	65.1
101	1511.09	5148.85	1576.19	5213.95	65.1	65.1
102	1321.845	5148.85	1386.945	5213.95	65.1	65.1
103	1203.615	5148.85	1268.715	5213.95	65.1	65.1
104	1085.385	5148.85	1150.485	5213.95	65.1	65.1
105	967.155	5148.85	1032.255	5213.95	65.1	65.1
106	843.185	5148.85	908.285	5213.95	65.1	65.1
107	719.215	5148.85	784.315	5213.95	65.1	65.1
108	595.245	5148.85	660.345	5213.95	65.1	65.1
109	471.275	5148.85	536.375	5213.95	65.1	65.1
110	347.305	5148.85	412.405	5213.95	65.1	65.1
111	223.335	5148.85	288.435	5213.95	65.1	65.1
112	10.08	4979.975	75.18	5045.075	65.1	65.1
113	10.08	4868.5	75.18	4933.6	65.1	65.1
114	10.08	4757.025	75.18	4822.125	65.1	65.1
115	10.08	4645.55	75.18	4710.65	65.1	65.1
116	10.08	4534.075	75.18	4599.175	65.1	65.1
117	10.08	4410.105	75.18	4475.205	65.1	65.1
118	10.08	4286.135	75.18	4351.235	65.1	65.1
119	10.08	4162.165	75.18	4227.265	65.1	65.1
120	10.08	4038.195	75.18	4103.295	65.1	65.1
121	10.08	3912.825	75.18	3977.925	65.1	65.1
122	10.08	3801.35	75.18	3866.45	65.1	65.1
123	10.08	3689.875	75.18	3754.975	65.1	65.1
124	10.08	3578.4	75.18	3643.5	65.1	65.1
125	10.08	3466.925	75.18	3532.025	65.1	65.1
126	10.08	3355.45	75.18	3420.55	65.1	65.1
127	10.08	3243.975	75.18	3309.075	65.1	65.1
128	10.08	3132.5	75.18	3197.6	65.1	65.1
129	10.08	3021.025	75.18	3086.125	65.1	65.1
130	10.08	2909.55	75.18	2974.65	65.1	65.1
131	10.08	2720.305	75.18	2785.405	65.1	65.1
132	10.08	2608.83	75.18	2673.93	65.1	65.1
133	10.08	2497.355	75.18	2562.455	65.1	65.1
134	10.08	2385.88	75.18	2450.98	65.1	65.1
135	10.08	2274.405	75.18	2339.505	65.1	65.1
136	10.08	2162.93	75.18	2228.03	65.1	65.1
137	10.08	2051.455	75.18	2116.555	65.1	65.1
138	10.08	1862.21	75.18	1927.31	65.1	65.1

Table 4-1. Bond Pad Coordinates (continued)

PAD NO.	BOND PAD COORDINATES (μm)				PAD SIZE (μm)	
	X MIN	Y MIN	X MAX	Y MAX	X	Y
139	10.08	1672.965	75.18	1738.065	65.1	65.1
140	10.08	1561.49	75.18	1626.59	65.1	65.1
141	10.08	1372.245	75.18	1437.345	65.1	65.1
142	10.08	1260.77	75.18	1325.87	65.1	65.1
143	10.08	1149.295	75.18	1214.395	65.1	65.1
144	10.08	1037.82	75.18	1102.92	65.1	65.1
145	10.08	926.345	75.18	991.445	65.1	65.1
146	10.08	814.87	75.18	879.97	65.1	65.1
147	10.08	703.395	75.18	768.495	65.1	65.1
148	10.08	514.15	75.18	579.25	65.1	65.1
149	10.08	402.675	75.18	467.775	65.1	65.1
150	10.08	291.2	75.18	356.3	65.1	65.1
151	10.08	179.725	75.18	244.825	65.1	65.1
152	4.9	5154.1	69.93	5219.13	65.03	65.03

5 Pin Configuration and Functions

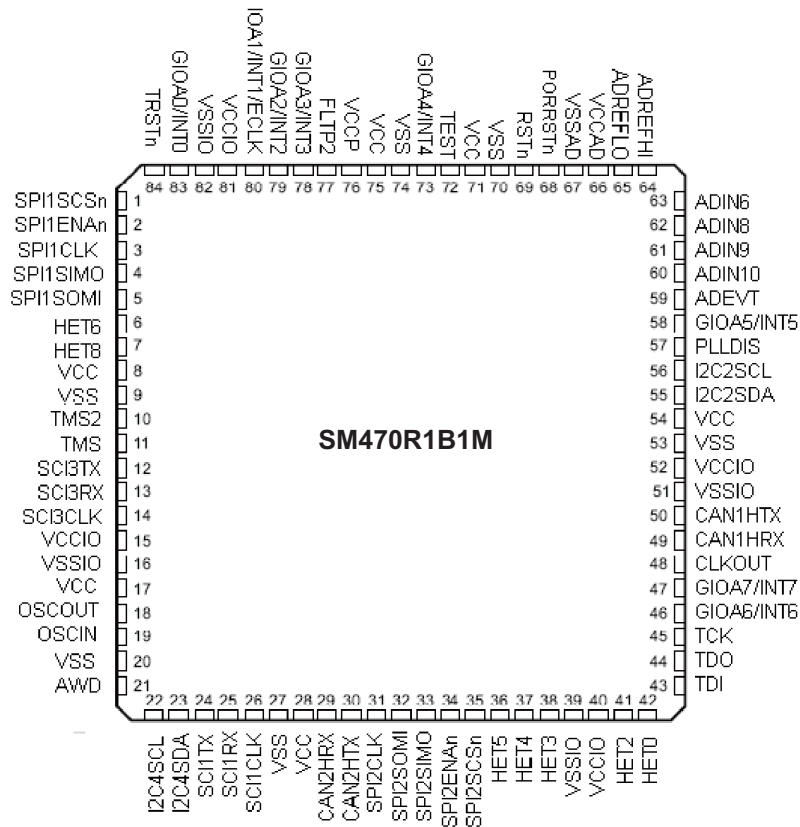

Figure 5-1. SM470R1B1M HFQ/HKP Packages, 84-Pin CQFP Ceramic Quad Flatpack (Top View)

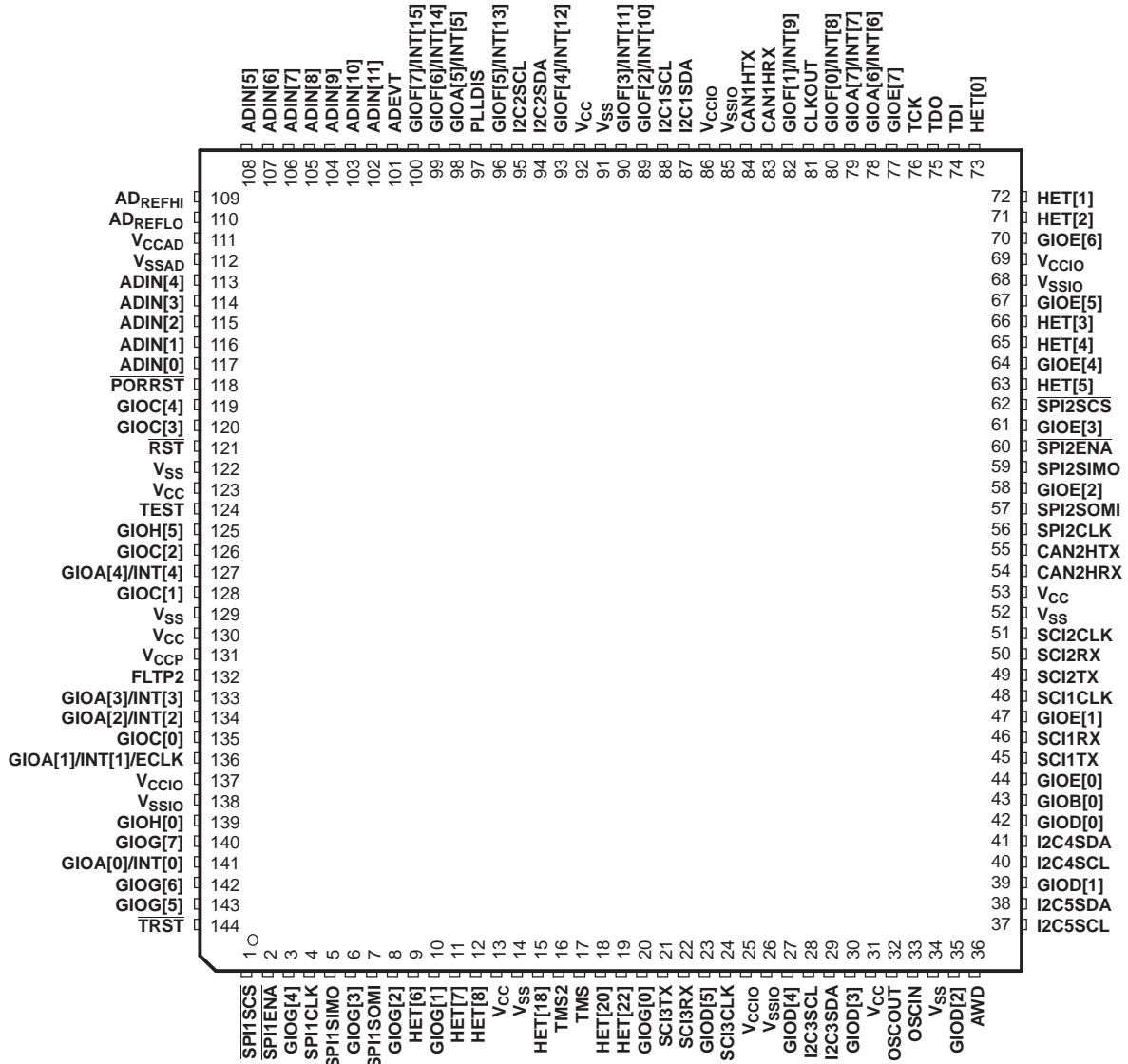

Figure 5-2. SM470R1B1M-HT PGE Package, 144-Pin LQFP Plastic Low-Profile Quad Flatpack Without Expansion Bus (Top View)

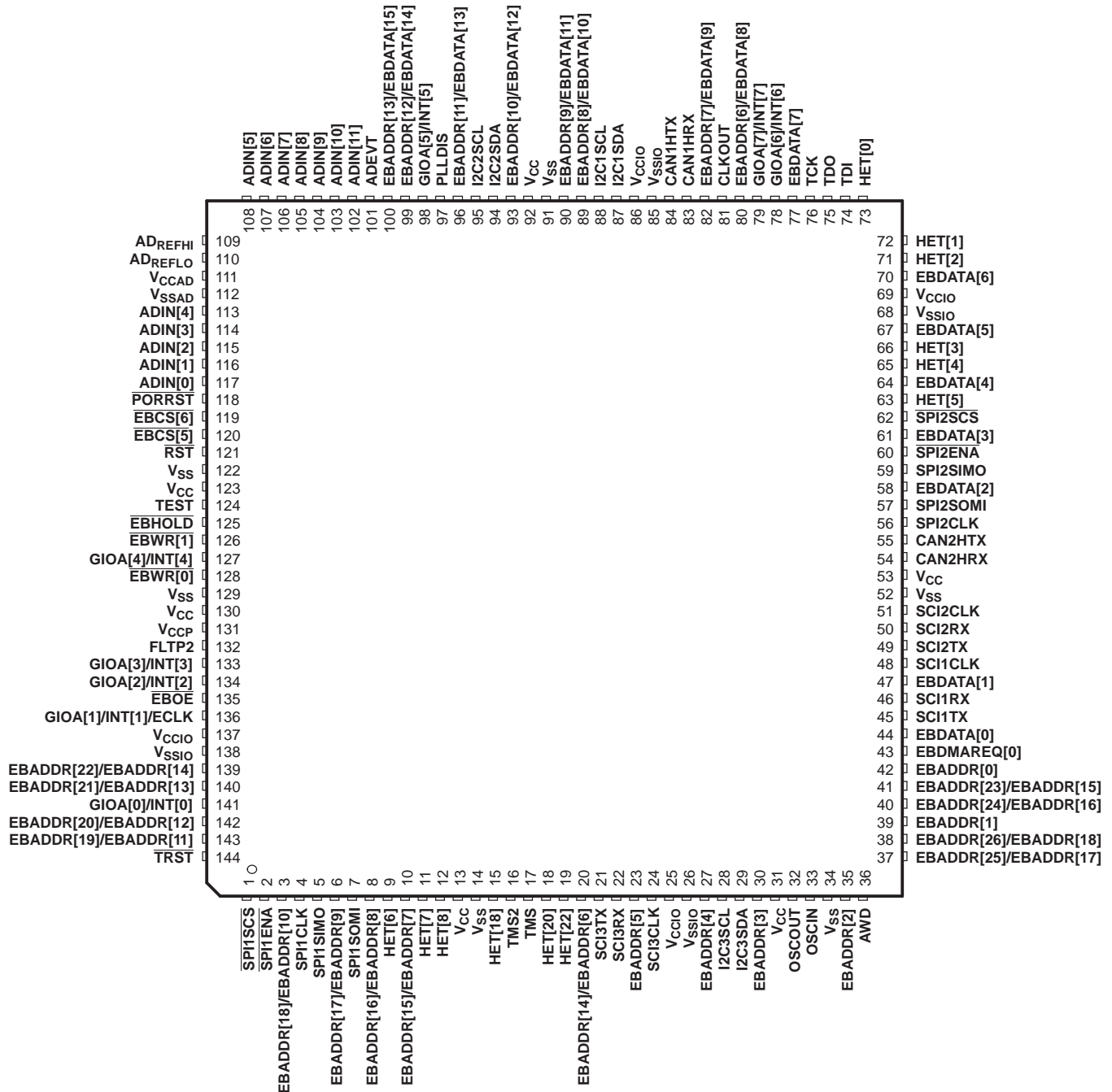

Figure 5-3. SM470R1B1M-HT PGE Package 144-Pin LQFP Plastic Low-Profile Quad Flatpack With Expansion Bus (Top View)

5.1 Features

The reduced pin count version of SM470R1B1M has the following features.

- Communication interfaces
 - Two SPIs
 - Two SCIs
 - Two HECC
 - Two I²C modules
- 4-channel, 10-bit MibADC

- High-end timer lite (HET) controlling seven programmable I/O channels
- Eight general-purpose I/Os

5.2 Pin Functions (HFQ/HKP Package)

PIN			TYPE ^{(1) (2)}	CURRENT OUTPUT	INTERNAL PULLUP/PULLDOWN ⁽³⁾	DESCRIPTION
NAME	PAD NO.	HFQ/HKP ⁽⁴⁾				
HIGH-END TIMER (HET)						
HET[0]	76	42	3.3 V	2 mA -z	IPD (20 µA)	Timer input capture or output compare. The HET[8:0,18,20,22] applicable pins can be programmed as general-purpose input/output (GIO) pins. All are high-resolution pins. The high-resolution (HR) SHARE feature allows even HR pins to share the next higher odd HR pin structures. This HR sharing is independent of whether or not the odd pin is available externally. If an odd pin is available externally and shared, then the odd pin can only be used as a general-purpose I/O. For more information on HR SHARE, see the <i>TMS470R1x High-End Timer (HET) Reference Guide (SPNU199)</i> .
HET[1]	75	NC				
HET[2]	74	41				
HET[3]	69	38				
HET[4]	68	37				
HET[5]	66	36				
HET[6]	9	6				
HET[7]	11	NC				
HET[8]	13	7				
HET[18]	16	NC				
HET[20]	19	NC				
HET[22]	20	NC				
HIGH-END CAN CONTROLLER (HECC)						
CAN1HRX	86	49	5-V tolerant	4 mA		HECC1 receive pin or GIO pin
CAN1HTX	87	50	3.3 V	2 mA -z	IPU (20 µA)	HECC1 transmit pin or GIO pin
CAN2HRX	57	29	5-V tolerant	4 mA		HECC2 receive pin or GIO pin
CAN2HTX	58	30	3.3 V	2 mA -z	IPU (20 µA)	HECC2 transmit pin or GIO pin
GENERAL-PURPOSE I/O (GIO)						
GIOA[0]/INT[0]	147	83	5-V tolerant	4 mA		General-purpose input/output pins. GIOA[7:0]/INT[7:0] are interrupt-capable pins. GIOA[1]/INT[1]/ECLK pin is multiplexed with the external clock-out function of the external clock prescale (ECP) module.
GIOA[1]/INT[1]/ECLK	140	80				
GIOA[2]/INT[2]	138	79				
GIOA[3]/INT[3]	137	78				
GIOA[4]/INT[4]	130	73				
GIOA[5]/INT[5]	101	58				
GIOA[6]/INT[6]	81	46				
GIOA[7]/INT[7]	82	47				
GIOB[0]/EBDMAREQ0	46	NC	3.3 V	2 mA -z	IPD (20 µA)	GIOB[0], GIOC[4:0], GIOD[5:0], GIOE[7:0], GIOF[7:0], GIOG[7:0], and GIOH[5:0] are multiplexed with the expansion bus module. See Table 8-3 .
GIOC[0]/EBOE	139	NC				
GIOC[1]/EBWR[0]	131	NC				
GIOC[2]/EBWR[1]	129	NC				
GIOC[3]/EBCS[5]	123	NC				
GIOC[4]/EBCS[6]	122	NC				

- (1) PWR = power, GND = ground, REF = reference voltage, NC = no connect
- (2) All I/O pins, except \overline{RST} , are configured as inputs while \overline{PORRST} is low and immediately after \overline{PORRST} goes high.
- (3) IPD = internal pulldown, IPU = internal pullup (all internal pullups and pulldowns are active on input pins, independent of the \overline{PORRST} state.)
- (4) Any pins marked as NC are physically connected to ground internal to the package. Care must be used to keep these pins in a high impedance input state.

PIN			TYPE ⁽¹⁾ (2)	CURRENT OUTPUT	INTERNAL PULLUP/PULLDOWN ⁽³⁾	DESCRIPTION
NAME	PAD NO.	HFQ/HKP ⁽⁴⁾				
GIOD[0]/EBADDR[0]	45	NC	3.3 V	2 mA -z	IPD (20 µA)	<p>GIOD[0], GIOE[4:0], GIOE[7:0], GIOF[7:0], GIOG[7:0], and GIOH[5,0] are multiplexed with the expansion bus module.</p> <p>GIOF[7:0]/INT[15:8] are interrupt-capable pins.</p> <p>See Table 8-3.</p>
GIOD[1]/EBADDR[1]	42	NC				
GIOD[2]/EBADDR[2]	38	NC				
GIOD[3]/EBADDR[3]	33	NC				
GIOD[4]/EBADDR[4]	30	NC				
GIOD[5]/EBADDR[5]	25	NC				
GIOE[0]/EBDATA[0]	47	NC				
GIOE[1]/EBDATA[1]	50	NC				
GIOE[2]/EBDATA[2]	61	NC				
GIOE[3]/EBDATA[3]	64	NC				
GIOE[4]/EBDATA[4]	67	NC				
GIOE[5]/EBDATA[5]	70	NC				
GIOE[6]/EBDATA[6]	73	NC				
GIOE[7]/EBDATA[7]	80	NC				
GIOF[0]/INT[8]/EBADDR[6]/EBDATA[8]	83	NC				
GIOF[1]/INT[9]/EBADDR[7]/EBDATA[9]	85	NC				
GIOF[2]/INT[10]/EBADDR[8]/EBDATA[10]	92	NC				
GIOF[3]/INT[11]/EBADDR[9]/EBDATA[11]	93	NC				
GIOF[4]/INT[12]/EBADDR[10]/EBDATA[12]	96	NC				
GIOF[5]/INT[13]/EBADDR[11]/EBDATA[13]	99	NC				
GIOF[6]/INT[14]/EBADDR[12]/EBDATA[14]	102	NC				
GIOF[7]/INT[15]/EBADDR[13]/EBDATA[15]	103	NC				
GIOG[0]/EBADDR[14]/EBADDR[6]	21	NC				
GIOG[1]/EBADDR[15]/EBADDR[7]	10	NC				
GIOG[2]/EBADDR[16]/EBADDR[8]	8	NC				
GIOG[3]/EBADDR[17]/EBADDR[9]	6	NC				
GIOG[4]/EBADDR[18]/EBADDR[10]	3	NC				
GIOG[5]/EBADDR[19]/EBADDR[11]	150	NC				
GIOG[6]/EBADDR[20]/EBADDR[12]	148	NC				
GIOG[7]/EBADDR[21]/EBADDR[13]	145	NC				
GIOH[0]/EBADDR[22]/EBADDR[14]	144	NC				
GIOH[5]/EBHOLD	128	NC				

PIN			TYPE ⁽¹⁾ (2)	CURRENT OUTPUT	INTERNAL PULLUP/PULLDOWN ⁽³⁾	DESCRIPTION
NAME	PAD NO.	HFQ/HKP ⁽⁴⁾				
MULTI-BUFFERED ANALOG-TO-DIGITAL CONVERTER (MibADC)						
ADEVT	104	59	3.3 V	2 mA -z	IPD (20 µA)	MibADC event input. Can be programmed as a GIO pin.
ADIN[0]	120	NC				MibADC analog input pins
ADIN[1]	119	NC				
ADIN[2]	118	NC				
ADIN[3]	117	NC				
ADIN[4]	116	NC				
ADIN[5]	111	NC				
ADIN[6]	110	63				
ADIN[7]	109	NC				
ADIN[8]	108	62				
ADIN[9]	107	61				
ADIN[10]	106	60				
ADIN[11]	105	NC				
AD _{REFHI}	112	64	3.3 VREF			MibADC module high-voltage reference input
AD _{REFLO}	113	65	GND REF			MibADC module low-voltage reference input
V _{CCAD}	114	66	3.3-V PWR			MibADC analog supply voltage
V _{SSAD}	115	67	GND			MibADC analog ground reference
SERIAL PERIPHERAL INTERFACE 1 (SPI1)						
SPI1CLK	4	3	5-V tolerant	4 mA		SPI1 clock. SPI1CLK can be programmed as a GIO pin.
$\overline{\text{SPI1ENA}}$	2	2				SPI1 chip enable. Can be programmed as a GIO pin.
$\overline{\text{SPI1SCS}}$	1	1				SPI1 slave chip select. Can be programmed as a GIO pin.
SPI1SIMO	5	4				SPI1 data stream. Slave in/master out. Can be programmed as a GIO pin.
SPI1SOMI	7	5				SPI1 data stream. Slave out/master in. Can be programmed as a GIO pin.
SERIAL PERIPHERAL INTERFACE 2 (SPI2)						
SPI2CLK	59	31	5-V tolerant	4 mA		SPI2 clock. Can be programmed as a GIO pin.
$\overline{\text{SPI2ENA}}$	63	34				SPI2 chip enable. Can be programmed as a GIO pin.
$\overline{\text{SPI2SCS}}$	65	35				SPI2 slave chip select. Can be programmed as a GIO pin.
SPI2SIMO	62	33				SPI2 data stream. Slave in/master out. Can be programmed as a GIO pin.
SPI2SOMI	60	32				SPI2 data stream. Slave out/master in. Can be programmed as a GIO pin.
INTER-INTEGRATED CIRCUIT 1 (I2C1)						
I2C1SDA	90	NC	5-V tolerant	4 mA		I2C1 serial data pin or GIO pin
I2C1SCL	91	NC				I2C1 serial clock pin or GIO pin

PIN			TYPE ⁽¹⁾ (2)	CURRENT OUTPUT	INTERNAL PULLUP/PULLDOWN ⁽³⁾	DESCRIPTION
NAME	PAD NO.	HFQ/HKP ⁽⁴⁾				
INTER-INTEGRATED CIRCUIT 2 (I2C2)						
I2C2SDA	97	55	5-V tolerant	4 mA		I2C2 serial data pin or GIO pin
I2C2SCL	98	56				I2C2 serial clock pin or GIO pin
INTER-INTEGRATED CIRCUIT 3 (I2C3)						
I2C3SDA	32	NC	5-V tolerant	4 mA		I2C3 serial data pin or GIO pin
I2C3SCL	31	NC				I2C3 serial clock pin or GIO pin
INTER-INTEGRATED CIRCUIT 4 (I2C4)						
I2C4SDA	44	23	5-V tolerant	4 mA		I2C4 serial data pin or GIO pin
I2C4SCL	43	22				I2C4 serial clock pin or GIO pin
INTER-INTEGRATED CIRCUIT 5 (I2C5)						
I2C5SDA	41	NC	5-V tolerant	4 mA		I2C5 serial data pin or GIO pin
I2C5SCL	40	NC				I2C5 serial clock pin or GIO pin
ZERO-PIN PHASE-LOCKED LOOP (ZPLL)						
OSCIN	36	19	1.8 V			Crystal connection pin or external clock input
OSCOU	35	18		2 mA		External crystal connection pin
PLLDIS	100	57	3.3 V		IPD (20 µA)	Enable/disable the ZPLL. The ZPLL can be bypassed and the oscillator becomes the system clock. If not in bypass mode, TI recommends that this pin be connected to ground or pulled down to ground by an external resistor.
SERIAL COMMUNICATIONS INTERFACE 1 (SCI1)						
SCI1CLK	51	26	3.3 V	2 mA -z	IPD (20 µA)	SCI1 clock. SCI1CLK can be programmed as a GIO pin.
SCI1RX	49	25	5-V tolerant	4 mA		SCI1 data receive. SCI1RX can be programmed as a GIO pin.
SCI1TX	48	24	3.3 V	2 mA -z	IPU (20 µA)	SCI1 data transmit. SCI1TX can be programmed as a GIO pin.
SERIAL COMMUNICATIONS INTERFACE 2 (SCI2)						
SCI2CLK	54	NC	3.3 V	2 mA -z	IPD (20 µA)	SCI2 clock. SCI2CLK can be programmed as a GIO pin.
SCI2RX	53	NC	5-V tolerant	4 mA		SCI2 data receive. SCI2RX can be programmed as a GIO pin.
SCI2TX	52	NC	3.3 V	2 mA -z	IPU (20 µA)	SCI2 data transmit. SCI2TX can be programmed as a GIO pin.
SERIAL COMMUNICATIONS INTERFACE 3 (SCI3)						
SCI3CLK	27	14	3.3 V	2 mA -z	IPD (20 µA)	SCI3 clock. SCI3CLK can be programmed as a GIO pin.
SCI3RX	24	13	5-V tolerant	4 mA		SCI3 data receive. SCI3RX can be programmed as a GIO pin.
SCI3TX	23	12	3.3 V	2 mA -z	IPU (20 µA)	SCI3 data transmit. SCI3TX can be programmed as a GIO pin.
SYSTEM MODULE (SYS)						
CLKOUT	84	48	3.3 V	8 mA		Bidirectional pin. CLKOUT can be programmed as a GIO pin or the output of SYSCLK, ICLK, or MCLK.
$\overline{\text{PORRST}}$	121	68	3.3 V		IPD (20 µA)	Input master chip power-up reset. External V _{CC} monitor circuitry must assert a power-on reset.
$\overline{\text{RST}}$	124	69	3.3 V	4 mA	IPU (20 µA)	Bidirectional reset. The internal circuitry can assert a reset, and an external system reset can assert a device reset. On this pin, the output buffer is implemented as an open drain (drives low only). To ensure an external reset is not arbitrarily generated, TI recommends that an external pullup resistor be connected to this pin.

PIN			TYPE ⁽¹⁾ (2)	CURRENT OUTPUT	INTERNAL PULLUP/PULLDOWN ⁽³⁾	DESCRIPTION
NAME	PAD NO.	HFQ/HKP ⁽⁴⁾				
WATCHDOG/REAL-TIME INTERRUPT (WD/RTI)						
AWD	39	21	3.3 V	8 mA		Analog watchdog reset. The AWD pin provides a system reset if the WD KEY is not written in time by the system, providing an external RC network circuit is connected. If the user is not using AWD, TI recommends that this pin be connected to ground or pulled down to ground by an external resistor. For more details on the external RC network circuit, see the <i>TMS470R1x System Module Reference Guide (SPNU189)</i> .
TEST/DEBUG (T/D)						
TCK	79	45	3.3 V		IPD (20 μ A)	Test clock. TCK controls the test hardware (JTAG).
TDI	77	43		8 mA	IPU (20 μ A)	Test data in. TDI inputs serial data to the test instruction register, test data register, and programmable test address (JTAG).
TDO	78	44		8 mA	IPD (20 μ A)	Test data out. TDO outputs serial data from the test instruction register, test data register, identification register, and programmable test address (JTAG).
TEST	127	72	3.3 V		IPD (20 μ A)	Test enable. Reserved for internal use only. TI recommends that this pin be connected to ground or pulled down to ground by an external resistor.
TMS	18	11		8 mA	IPU (20 μ A)	Serial input for controlling the state of the CPU test access port (TAP) controller (JTAG).
TMS2	17	10		8 mA	IPU (20 μ A)	Serial input for controlling the second TAP. TI recommends that this pin be connected to V_{CCIO} or pulled up to V_{CCIO} by an external resistor.
$\overline{\text{TRST}}$	151	84			IPD (20 μ A)	Test hardware reset to TAP1 and TAP2. IEEE Standard 1149-1 (JTAG) Boundary-Scan Logic. TI recommends that this pin be pulled down to ground by an external resistor.
FLASH						
FLTP2	135	77	NC	NC		Flash test pad 2. For proper operation, this pin must not be connected [no connect (NC)].
V_{CCP}	134	76	3.3-V PWR			Flash external pump voltage (3.3 V)
SUPPLY VOLTAGE CORE (1.8 V)						
V_{CC}	14	8	1.8-V PWR			Core logic supply voltage
	34	17				
	56	28				
	95	54				
	126	71				
	133	75				

PIN			TYPE ^{(1) (2)}	CURRENT OUTPUT	INTERNAL PULLUP/PULLDOWN ⁽³⁾	DESCRIPTION
NAME	PAD NO.	HFQ/HKP ⁽⁴⁾				
SUPPLY VOLTAGE DIGITAL I/O (3.3 V)						
V _{CCIO}	28	15	3.3-V PWR			Digital I/O supply voltage
	72	40				
	89	52				
	141	81				
SUPPLY GROUND CORE						
V _{SS}	15	9	GND			Core supply ground reference
	37	20				
	55	27				
	94	53				
	125	70				
	132	74				
SUPPLY GROUND DIGITAL I/O						
V _{SSIO}	29	16	GND			Digital I/O supply ground reference
	71	39				
	88	51				
	142	82				

5.3 Pin Functions (PGE Package)

PIN		TYPE ^{(1) (2)}	CURRENT OUTPUT	INTERNAL PULLUP/PULLDOWN ⁽³⁾	DESCRIPTION
NAME	NO.				
HIGH-END TIMER (HET)					
HET[0]	73	3.3 V	2 mA -z	IPD (20 µA)	<p>Timer input capture or output compare. The HET[8:0,18,20,22] applicable pins can be programmed as general-purpose input/output (GIO) pins. All are high-resolution pins.</p> <p>The high-resolution (HR) SHARE feature allows even HR pins to share the next higher odd HR pin structures. This HR sharing is independent of whether or not the odd pin is available externally. If an odd pin is available externally and shared, then the odd pin can only be used as a general-purpose I/O. For more information on HR SHARE, see the <i>TMS470R1x High-End Timer (HET) Reference Guide</i> (SPNU199).</p>
HET[1]	72				
HET[2]	71				
HET[3]	66				
HET[4]	65				
HET[5]	63				
HET[6]	9				
HET[7]	11				
HET[8]	12				
HET[18]	15				
HET[20]	18				
HET[22]	19				
HIGH-END CAN CONTROLLER (HECC)					
CAN1HRX	83	5-V tolerant	4 mA		HECC1 receive pin or GIO pin
CAN1HTX	84	3.3 V	2 mA -z	IPU (20 µA)	HECC1 transmit pin or GIO pin
CAN2HRX	54	5-V tolerant	4 mA		HECC2 receive pin or GIO pin
CAN2HTX	55	3.3 V	2 mA -z	IPU (20 µA)	HECC2 transmit pin or GIO pin
STANDARD CAN CONTROLLER (SCC)					
CANSRX	-	5-V tolerant	4 mA		SCC receive pin. The CANSRX signal is only connected to the pad and not to a package pin. For reduced power consumption in low power mode, CANSRX should be driven output LOW.

(1) PWR = power, GND = ground, REF = reference voltage, NC = no connect

(2) All I/O pins, except RST, are configured as inputs while PORRST is low and immediately after PORRST goes high.

(3) IPD = internal pulldown, IPU = internal pullup (all internal pullups and pulldowns are active on input pins, independent of the PORRST state.)

PIN		TYPE ⁽¹⁾ (2)	CURRENT OUTPUT	INTERNAL PULLUP/PULLDOWN ⁽³⁾	DESCRIPTION
NAME	NO.				
CANSTX	-	3.3 V	2 mA -z	IPU (20 μ A)	SCC transmit pin. The CANSTX signal is only connected to the pad and not to a package pin. For reduced power consumption in low power mode, CANSTX should be driven output LOW.
GENERAL-PURPOSE I/O (GIO)					
GIOA[0]/INT[0]	141	5-V tolerant	4 mA		General-purpose input/output pins. GIOA[7:0]/INT[7:0] are interrupt-capable pins. GIOA[1]/INT[1]/ECLK pin is multiplexed with the external clock-out function of the external clock prescale (ECP) module.
GIOA[1]/INT[1]/ECLK	136				
GIOA[2]/INT[2]	134				
GIOA[3]/INT[3]	133				
GIOA[4]/INT[4]	127				
GIOA[5]/INT[5]	98				
GIOA[6]/INT[6]	78				
GIOA[7]/INT[7]	79				
GIOB[0]/EBDMAREQ0	43	3.3 V	2 mA -z	IPD (20 μ A)	GIOB[0], GIOC[4:0], GIOD[5:0], GIOE[7:0:], GIOF[7:0], GIOG[7:0], and GIOH[5,0] are multiplexed with the expansion bus module. See Table 8-3 .
GIOC[0]/ $\overline{\text{EBOE}}$	135				
GIOC[1]/ $\overline{\text{EBWR}}[0]$	128				
GIOC[2]/ $\overline{\text{EBWR}}[1]$	126				
GIOC[3]/ $\overline{\text{EBCS}}[5]$	120				
GIOC[4]/ $\overline{\text{EBCS}}[6]$	119				

PIN		TYPE ⁽¹⁾ (2)	CURRENT OUTPUT	INTERNAL PULLUP/PULLDOWN ⁽³⁾	DESCRIPTION
NAME	NO.				
GIOD[0]/EBADDR[0]	42	3.3 V	2 mA -z	IPD (20 µA)	GIOB[0], GIOC[4:0], GIOD[5:0], GIOE[7:0:], GIOF[7:0], GIOG[7:0], and GIOH[5,0] are multiplexed with the expansion bus module. GIOF[7:0]/INT[15:8] are interrupt-capable pins. See Table 8-3 .
GIOD[1]/EBADDR[1]	39				
GIOD[2]/EBADDR[2]	35				
GIOD[3]/EBADDR[3]	30				
GIOD[4]/EBADDR[4]	27				
GIOD[5]/EBADDR[5]	23				
GIOE[0]/EBDATA[0]	44				
GIOE[1]/EBDATA[1]	47				
GIOE[2]/EBDATA[2]	58				
GIOE[3]/EBDATA[3]	61				
GIOE[4]/EBDATA[4]	64				
GIOE[5]/EBDATA[5]	67				
GIOE[6]/EBDATA[6]	70				
GIOE[7]/EBDATA[7]	77				
GIOF[0]/INT[8]/EBADDR[6]/EBDATA[8]	80				
GIOF[1]/INT[9]/EBADDR[7]/EBDATA[9]	82				
GIOF[2]/INT[10]/EBADDR[8]/EBDATA[10]	89				
GIOF[3]/INT[11]/EBADDR[9]/EBDATA[11]	90				
GIOF[4]/INT[12]/EBADDR[10]/EBDATA[12]	93				
GIOF[5]/INT[13]/EBADDR[11]/EBDATA[13]	96				
GIOF[6]/INT[14]/EBADDR[12]/EBDATA[14]	99				
GIOF[7]/INT[15]/EBADDR[13]/EBDATA[15]	100				
GIOG[0]/EBADDR[14]/EBADDR[6]	20				
GIOG[1]/EBADDR[15]/EBADDR[7]	10				
GIOG[2]/EBADDR[16]/EBADDR[8]	8				
GIOG[3]/EBADDR[17]/EBADDR[9]	6				
GIOG[4]/EBADDR[18]/EBADDR[10]	3				
GIOG[5]/EBADDR[19]/EBADDR[11]	143				
GIOG[6]/EBADDR[20]/EBADDR[12]	142				
GIOG[7]/EBADDR[21]/EBADDR[13]	140				
GIOH[0]/EBADDR[22]/EBADDR[14]	139				
GIOH[5]/EBHOLD	125				

PIN		TYPE ⁽¹⁾ (2)	CURRENT OUTPUT	INTERNAL PULLUP/PULLDOWN ⁽³⁾	DESCRIPTION
NAME	NO.				
MULTI-BUFFERED ANALOG-TO-DIGITAL CONVERTER (MibADC)					
ADEVT	101	3.3 V	2 mA -z	IPD (20 µA)	MibADC event input. Can be programmed as a GIO pin.
ADIN[0]	117				MibADC analog input pins
ADIN[1]	116				
ADIN[2]	115				
ADIN[3]	114				
ADIN[4]	113				
ADIN[5]	108				
ADIN[6]	107				
ADIN[7]	106				
ADIN[8]	105				
ADIN[9]	104				
ADIN[10]	103				
ADIN[11]	102				
AD _{REFHI}	109	3.3 VREF			MibADC module high-voltage reference input
AD _{REFLO}	110	GND REF			MibADC module low-voltage reference input
V _{CCAD}	111	3.3-V PWR			MibADC analog supply voltage
V _{SSAD}	112	GND			MibADC analog ground reference
SERIAL PERIPHERAL INTERFACE 1 (SPI1)					
SPI1CLK	4	5-V tolerant	4 mA		SPI1 clock. SPI1CLK can be programmed as a GIO pin.
$\overline{\text{SPI1ENA}}$	2				SPI1 chip enable. Can be programmed as a GIO pin.
$\overline{\text{SPI1SCS}}$	1				SPI1 slave chip select. Can be programmed as a GIO pin.
SPI1SIMO	5				SPI1 data stream. Slave in/master out. Can be programmed as a GIO pin.
SPI1SOMI	7				SPI1 data stream. Slave out/master in. Can be programmed as a GIO pin.
SERIAL PERIPHERAL INTERFACE 2 (SPI2)					
SPI2CLK	56	5-V tolerant	4 mA		SPI2 clock. Can be programmed as a GIO pin.
$\overline{\text{SPI2ENA}}$	60				SPI2 chip enable. Can be programmed as a GIO pin.
$\overline{\text{SPI2SCS}}$	62				SPI2 slave chip select. Can be programmed as a GIO pin.
SPI2SIMO	59				SPI2 data stream. Slave in/master out. Can be programmed as a GIO pin.
SPI2SOMI	57				SPI2 data stream. Slave out/master in. Can be programmed as a GIO pin.
INTER-INTEGRATED CIRCUIT 1 (I2C1)					
I2C1SDA	87	5-V tolerant	4 mA		I2C1 serial data pin or GIO pin
I2C1SCL	88				I2C1 serial clock pin or GIO pin
INTER-INTEGRATED CIRCUIT 2 (I2C2)					
I2C2SDA	94	5-V tolerant	4 mA		I2C2 serial data pin or GIO pin
I2C2SCL	95				I2C2 serial clock pin or GIO pin

PIN		TYPE ⁽¹⁾ (2)	CURRENT OUTPUT	INTERNAL PULLUP/PULLDOWN ⁽³⁾	DESCRIPTION
NAME	NO.				
INTER-INTEGRATED CIRCUIT 3 (I2C3)					
I2C3SDA	29	5-V tolerant	4 mA		I2C3 serial data pin or GIO pin
I2C3SCL	28				I2C3 serial clock pin or GIO pin
INTER-INTEGRATED CIRCUIT 4 (I2C4)					
I2C4SDA	41	5-V tolerant	4 mA		I2C4 serial data pin or GIO pin
I2C4SCL	40				I2C4 serial clock pin or GIO pin
INTER-INTEGRATED CIRCUIT 5 (I2C5)					
I2C5SDA	38	5-V tolerant	4 mA		I2C5 serial data pin or GIO pin
I2C5SCL	37				I2C5 serial clock pin or GIO pin
ZERO-PIN PHASE-LOCKED LOOP (ZPLL)					
OSCIN	33	1.8 V			Crystal connection pin or external clock input
OSCOU	32		2 mA		External crystal connection pin
PLLDIS	97	3.3 V		IPD (20 µA)	Enable/disable the ZPLL. The ZPLL can be bypassed and the oscillator becomes the system clock. If not in bypass mode, TI recommends that this pin be connected to ground or pulled down to ground by an external resistor.
SERIAL COMMUNICATIONS INTERFACE 1 (SCI1)					
SCI1CLK	48	3.3 V	2 mA -z	IPD (20 µA)	SCI1 clock. SCI1CLK can be programmed as a GIO pin.
SCI1RX	46	5-V tolerant	4 mA		SCI1 data receive. SCI1RX can be programmed as a GIO pin.
SCI1TX	45	3.3 V	2 mA -z	IPU (20 µA)	SCI1 data transmit. SCI1TX can be programmed as a GIO pin.
SERIAL COMMUNICATIONS INTERFACE 2 (SCI2)					
SCI2CLK	51	3.3 V	2 mA -z	IPD (20 µA)	SCI2 clock. SCI2CLK can be programmed as a GIO pin.
SCI2RX	50	5-V tolerant	4 mA		SCI2 data receive. SCI2RX can be programmed as a GIO pin.
SCI2TX	49	3.3 V	2 mA -z	IPU (20 µA)	SCI2 data transmit. SCI2TX can be programmed as a GIO pin.
SERIAL COMMUNICATIONS INTERFACE 3 (SCI3)					
SCI3CLK	24	3.3 V	2 mA -z	IPD (20 µA)	SCI3 clock. SCI3CLK can be programmed as a GIO pin.
SCI3RX	22	5-V tolerant	4 mA		SCI3 data receive. SCI3RX can be programmed as a GIO pin.
SCI3TX	21	3.3 V	2 mA -z	IPU (20 µA)	SCI3 data transmit. SCI3TX can be programmed as a GIO pin.
SYSTEM MODULE (SYS)					
CLKOUT	81	3.3 V	8 mA		Bidirectional pin. CLKOUT can be programmed as a GIO pin or the output of SYSCLK, ICLK, or MCLK.
$\overline{\text{PORRST}}$	118	3.3 V		IPD (20 µA)	Input master chip power-up reset. External V _{CC} monitor circuitry must assert a power-on reset.
$\overline{\text{RST}}$	121	3.3 V	4 mA	IPU (20 µA)	Bidirectional reset. The internal circuitry can assert a reset, and an external system reset can assert a device reset. On this pin, the output buffer is implemented as an open drain (drives low only). To ensure an external reset is not arbitrarily generated, TI recommends that an external pullup resistor be connected to this pin.

PIN		TYPE ⁽¹⁾ (2)	CURRENT OUTPUT	INTERNAL PULLUP/PULLDOWN ⁽³⁾	DESCRIPTION
NAME	NO.				
WATCHDOG/REAL-TIME INTERRUPT (WD/RTI)					
AWD	36	3.3 V	8 mA		Analog watchdog reset. The AWD pin provides a system reset if the WD KEY is not written in time by the system, providing an external RC network circuit is connected. If the user is not using AWD, TI recommends that this pin be connected to ground or pulled down to ground by an external resistor. For more details on the external RC network circuit, see the <i>TMS470R1x System Module Reference Guide (SPNU189)</i> .
TEST/DEBUG (T/D)					
TCK	76	3.3 V		IPD (20 μ A)	Test clock. TCK controls the test hardware (JTAG).
TDI	74		8 mA	IPU (20 μ A)	Test data in. TDI inputs serial data to the test instruction register, test data register, and programmable test address (JTAG).
TDO	75		8 mA	IPD (20 μ A)	Test data out. TDO outputs serial data from the test instruction register, test data register, identification register, and programmable test address (JTAG).
TEST	124	3.3 V		IPD (20 μ A)	Test enable. Reserved for internal use only. TI recommends that this pin be connected to ground or pulled down to ground by an external resistor.
TMS	17		8 mA	IPU (20 μ A)	Serial input for controlling the state of the CPU test access port (TAP) controller (JTAG).
TMS2	16		8 mA	IPU (20 μ A)	Serial input for controlling the second TAP. TI recommends that this pin be connected to V_{CCIO} or pulled up to V_{CCIO} by an external resistor.
$\overline{\text{TRST}}$	144			IPD (20 μ A)	Test hardware reset to TAP1 and TAP2. IEEE Standard 1149-1 (JTAG) Boundary-Scan Logic. TI recommends that this pin be pulled down to ground by an external resistor.
FLASH					
FLTP2	132	NC	NC		Flash test pad 2. For proper operation, this pin must not be connected [no connect (NC)].
V_{CCP}	131	3.3-V PWR			Flash external pump voltage (3.3 V)
SUPPLY VOLTAGE CORE (1.8 V)					
V_{CC}	13	1.8-V PWR			Core logic supply voltage
	31				
	53				
	92				
	123				
	130				
SUPPLY VOLTAGE DIGITAL I/O (3.3 V)					
V_{CCIO}	25	3.3-V PWR			Digital I/O supply voltage
	69				
	86				
	137				
SUPPLY GROUND CORE					
V_{SS}	14	GND			Core supply ground reference
	34				
	52				
	91				
	122				
	129				

PIN		TYPE ⁽¹⁾ (2)	CURRENT OUTPUT	INTERNAL PULLUP/ PULLDOWN ⁽³⁾	DESCRIPTION
NAME	NO.				
SUPPLY GROUND DIGITAL I/O					
V _{SSIO}	26	GND			Digital I/O supply ground reference
	68				
	85				
	138				

6 Specifications

6.1 Absolute Maximum Ratings

over operating free-air temperature range, A version (unless otherwise noted)⁽¹⁾

		MIN	MAX	UNIT
Supply voltage	V_{CC} ⁽²⁾	-0.3	2.5	V
Supply voltage	V_{CCIO} , V_{CCAD} , V_{CCP} (flash pump) ⁽²⁾	-0.3	4.1	V
Input voltage	All 5-V tolerant input pins	-0.3	6.0	V
	All other input pins	-0.3	4.1	V
Input clamp current	I_{IK} ($V_I < 0$ or $V_I > V_{CCIO}$) All pins except ADIN[0:11], \overline{PORRST} , \overline{TRST} , TEST, and TCK		±20	mA
	I_{IK} ($V_I < 0$ or $V_I > V_{CCAD}$) ADIN[0:11]		±10	mA
Operating free-air temperature, T_A	HFQ/HKP package	-55	220	°C
	PGE package	-55	150	°C
Storage temperature, T_{stg}		-55	220	°C

(1) Stresses beyond those listed under *Absolute Maximum Ratings* may cause permanent damage to the device. These are stress ratings only, and functional operation of the device at these or any other conditions beyond those indicated under *Recommended Operating Conditions* is not implied. Exposure to absolute-maximum-rated conditions for extended periods may affect device reliability.

(2) All voltage values are with respect to their associated grounds.

6.2 ESD Ratings

		VALUE	UNIT
SM470R1B1M-HT in CFP Package			
$V_{(ESD)}$ Electrostatic discharge	Human-body model (HBM), per ANSI/ESDA/JEDEC JS-001 ⁽¹⁾	2000	V
	Charged-device model (CDM), per JEDEC specification JESD22-C101 ⁽²⁾	750	
SM470R1B1M-HT in LQFP Package			
$V_{(ESD)}$ Electrostatic discharge	Human-body model (HBM), per ANSI/ESDA/JEDEC JS-001 ⁽¹⁾	2000	V
	Charged-device model (CDM), per JEDEC specification JESD22-C101 ⁽²⁾	750	

(1) JEDEC document JEP155 states that 500-V HBM allows safe manufacturing with a standard ESD control process.

(2) JEDEC document JEP157 states that 250-V CDM allows safe manufacturing with a standard ESD control process.

6.3 Recommended Operating Conditions⁽¹⁾

		MIN	NOM	MAX	UNIT
V_{CC} Digital logic supply voltage (Core)	SYSCLK = 48 MHz (pipeline mode enabled)	1.71		2.05	V
	SYSCLK = 60 MHz (pipeline mode enabled)	1.81		2.05	
V_{CCIO} Digital logic supply voltage (I/O)		3		3.6	V
V_{CCAD} ADC supply voltage		3		3.6	V
V_{CCP} Flash pump supply voltage		3		3.6	V
V_{SS} Digital logic supply ground			0		V
V_{SSAD} ADC supply ground ⁽¹⁾		-0.1		0.1	V
T_A Operating free-air temperature	HFQ/HKP package	-55		220	°C
	PGE package	-55		150	

(1) All voltages are with respect to V_{SS} , except V_{CCAD} , which is with respect to V_{SSAD} .

6.4 Electrical Characteristics

Minimum and maximum parameters are characterized over the operating temperature range unless otherwise noted, but may not be production tested at that temperature. Production test limits with statistical guardbands are used to ensure high temperature performance. ⁽¹⁾

PARAMETER		TEST CONDITIONS	MIN	TYP ⁽²⁾	MAX	UNIT	
V _{hys}	Input hysteresis			0.15		V	
V _{IL}	Low-level input voltage	All inputs ⁽³⁾	-0.3		0.8	V	
V _{IH}	High-level input voltage	All inputs	2	V _{CCIO} + 0.3		V	
	Input threshold voltage	AWD only ⁽⁴⁾	1.35		1.8		
		OSCIN with digital input only	0.7 V _{CC}		V _{CC} + 0.3		
V _{OL}	Low-level output voltage ⁽⁵⁾	I _{OL} = I _{OL} MAX			0.2 V _{CCIO}	V	
		I _{OL} = 50 μA			0.2		
V _{OH}	High-level output voltage ⁽⁵⁾	I _{OH} = I _{OH} MIN	0.8 V _{CCIO}			V	
		I _{OH} = 50 μA	V _{CCIO} - 0.2				
I _{IC}	Input clamp current (I/O pins) ⁽⁶⁾	V _I < V _{SSIO} - 0.3 or V _I > V _{CCIO} + 0.3	-2		2	mA	
I _I	Input current (3.3 V input pins)	I _{IL} Pulldown	V _I = V _{SS}	-1		1	μA
		I _{IH} Pulldown	V _I = V _{CCIO}	5		100	
		I _{IL} Pullup	V _I = V _{SS}	-100		-5	
		I _{IH} Pullup	V _I = V _{CCIO}	-1		1	
		All other pins	No pullup or pulldown	-1		1	
	Input current (5 V tolerant input pins)	V _I = V _{SS}	-1		1	μA	
		V _I = V _{CCIO}	1		5		
		V _I = 5 V	5		25		
V _I = 5.5 V		25		50			
I _{OL}	Low-level output current	CLKOUT, AWD, TDI, TDO, TMS, TMS2	V _{OL} = V _{OL} MAX			8	mA
		$\overline{\text{RST}}$				4	
		All other 3.3 V I/O ⁽⁷⁾				2	
		5 V tolerant				4	
I _{OH}	High-level output current	CLKOUT, TDI, TDO, TMS, TMS2	V _{OH} = V _{OH} MIN			-8	mA
		$\overline{\text{RST}}$				-4	
		All other 3.3 V I/O ⁽⁷⁾				-2	
		5 V tolerant				-4	

- (1) Source currents (out of the device) are negative while sink currents (into the device) are positive.
- (2) The typical values indicated in this table are the expected values during operation under normal operating conditions: nominal V_{CC}, V_{CCIO}, or V_{CCAD}, room temperature.
- (3) This does not apply to the $\overline{\text{PORRST}}$ pin. For $\overline{\text{PORRST}}$ exceptions, see the $\overline{\text{RST}}$ and $\overline{\text{PORRST}}$ Timings section.
- (4) These values help to determine the external RC network circuit. For more details, see the *TMS470R1x System Module Reference Guide (SPNU189)*.
- (5) V_{OL} and V_{OH} are linear with respect to the amount of load current (I_{OL}/I_{OH}) applied.
- (6) Parameter does not apply to input-only or output-only pins.
- (7) Some of the 2 mA buffers on this device are zero-dominant buffers, as indicated by a -z in the Output Current column of the Pin Functions table. If two of these buffers are shorted together and one is outputting a low level and the other is outputting a high level, the resulting value will always be low.

Electrical Characteristics (continued)

Minimum and maximum parameters are characterized over the operating temperature range unless otherwise noted, but may not be production tested at that temperature. Production test limits with statistical guardbands are used to ensure high temperature performance. ⁽¹⁾

PARAMETER		TEST CONDITIONS	MIN	TYP ⁽²⁾	MAX	UNIT
I _{CC}	V _{CC} Digital supply current (operating mode)	SYSCLK = 48 MHz, ICLK = 24 MHz, V _{CC} = 2.05 V			110	mA
		SYSCLK = 60 MHz, ICLK = 30 MHz, V _{CC} = 2.05 V			125	mA
	V _{CC} Digital supply current (standby mode) ^{(8) (9)}	OSCIN = 5 MHz, V _{CC} = 2.05 V			28	mA
	V _{CC} Digital supply current (halt mode) ^{(8) (9)}	All frequencies, V _{CC} = 2.05 V			700	μA
I _{CCIO}	V _{CCIO} Digital supply current (operating mode)	No DC load, V _{CCIO} = 3.6 V ⁽¹⁰⁾			20	mA
	V _{CCIO} Digital supply current (standby mode) ⁽⁹⁾	No DC load, V _{CCIO} = 3.6 V ⁽¹⁰⁾			250	μA
	V _{CCIO} Digital supply current (halt mode) ⁽⁹⁾	No DC load, V _{CCIO} = 3.6 V ⁽¹⁰⁾			225	μA
I _{CCAD}	V _{CCAD} supply current (operating mode)	All frequencies, V _{CCAD} = 3.6 V			15	mA
	V _{CCAD} supply current (standby mode)	All frequencies, V _{CCAD} = 3.6 V			10	μA
	V _{CCAD} supply current (halt mode)	All frequencies, V _{CCAD} = 3.6 V			10	μA
I _{CCP}	V _{CCP} pump supply current	SYSCLK = 48 MHz, V _{CCP} = 3.6 V read operation			45	mA
		SYSCLK = 60 MHz, V _{CCP} = 3.6 V read operation			55	mA
		V _{CCP} = 3.6 V program and erase			70	mA
		V _{CCP} = 3.6 V standby mode operation ⁽⁸⁾			10	μA
		V _{CCP} = 3.6 V halt mode operation ⁽⁸⁾			10	μA
C _I	Input capacitance			2		pF
C _O	Output capacitance			3		pF

(8) For flash banks/pumps in sleep mode.

(9) For reduced power consumption in low power mode, CANSRX and CANSTX should be driven output LOW.

(10) I/O pins configured as inputs or outputs with no load. All pulldown inputs ≤ 0.2 V. All pullup inputs ≥ V_{CCIO} – 0.2 V.

6.5 Thermal Characteristics

THERMAL METRIC ⁽¹⁾		SM470R1B1M-HT		UNIT
		HFQ (CQFP) OR HKP (CFP)	PGE (LQFP)	
		64 PINS	144 PINS	
R _{θJA}	Junction-to-ambient thermal resistance	N/A	38.3	°C/W
R _{θJC(top)}	Junction-to-case (top) thermal resistance	N/A	5.7	°C/W
R _{θJB}	Junction-to-board thermal resistance	152.0148	19.7	°C/W
ψ _{JT}	Junction-to-top characterization parameter	N/A	0.1	°C/W
ψ _{JB}	Junction-to-board characterization parameter	N/A	19.3	°C/W
R _{θJC(bot)}	Junction-to-case (bottom) thermal resistance	5.4898	N/A	°C/W

(1) For more information about traditional and new thermal metrics, see the *Semiconductor and IC Package Thermal Metrics* application report, [SPRA953](#).

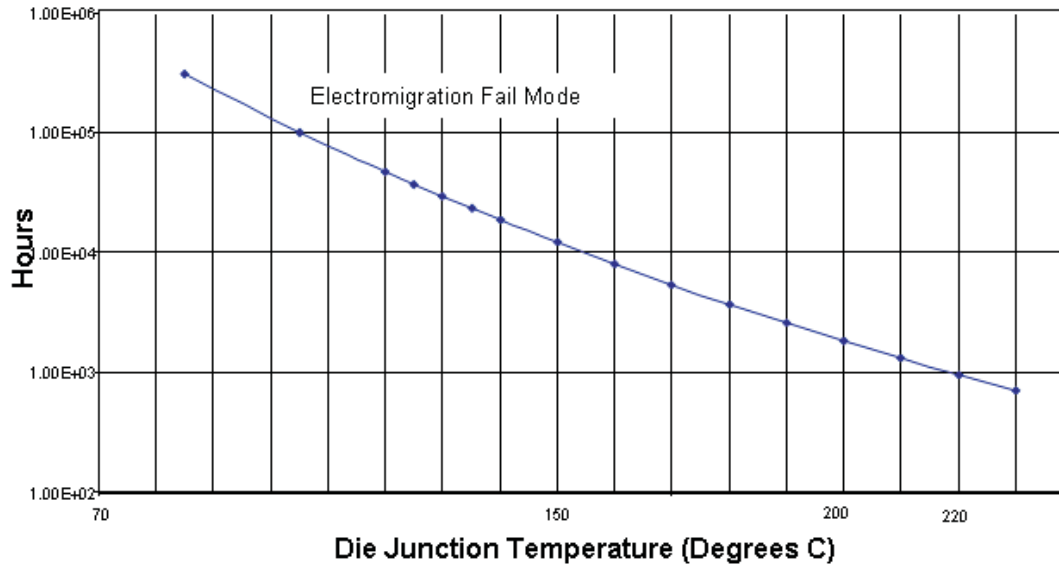

- (1) See data sheet for absolute maximum and minimum recommended operating conditions.
- (2) Silicon operating life design goal is 10 years at 105°C junction temperature (does not include package interconnect life).

Figure 6-1. SM470R1B1M-HT Life Expectancy Curve (HFQ/HKP Package)

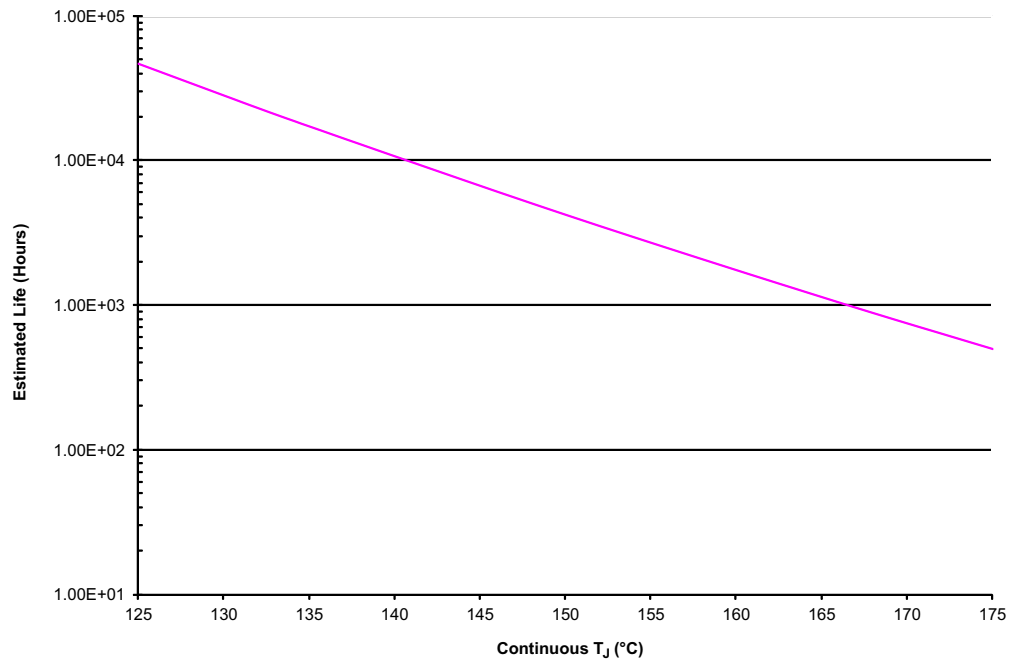

- (1) See data sheet for absolute maximum and minimum recommended operating conditions.
- (2) Silicon operating life design goal is 10 years at 105°C junction temperature (does not include package interconnect life).
- (3) Device is qualified for 1000 hour operation at 150°C. Device is functional at 175°C, but at reduced operating life.

Figure 6-2. SM470R1B1M-HT Wirebond Life Derating Chart (PGE Package)

6.6 ZPLL and Clock Specifications

Table 6-1. Timing Requirements for ZPLL Circuits Enabled or Disabled⁽¹⁾

		MIN	TYP	MAX	UNIT
$f_{(OSC)}$	Input clock frequency	4		10	MHz
$t_{c(O SC)}$	Cycle time, OSCIN	100			ns
$t_{w(O SCIL)}$	Pulse duration, OSCIN low	15			ns
$t_{w(O SCIH)}$	Pulse duration, OSCIN high	15			ns
$f_{(OSCRST)}$	OSC FAIL frequency ⁽²⁾		53		kHz

(1) Not production tested.

(2) Causes a device reset (specifically a clock reset) by setting the RST OSC FAIL (GLBCTRL.15) and the OSC FAIL flag (GLBSTAT.1) bits equal to 1. For more detailed information on these bits and device resets, see the *TMS470R1x System Module Reference Guide (SPNU189)*.

Table 6-2. Switching Characteristics over Recommended Operating Conditions for Clocks^{(1)(2) (3) (4)}

PARAMETER		TEST CONDITIONS ⁽⁵⁾	MIN	MAX	UNIT
$f_{(SYS)}$	System clock frequency ⁽⁶⁾	Pipeline mode enabled		60 ⁽⁷⁾	MHz
		Pipeline mode disabled		24	MHz
$f_{(CONFIG)}$	System clock frequency - flash config mode			24	MHz
$f_{(ICLK)}$	Interface clock frequency	Pipeline mode enabled		30	MHz
		Pipeline mode disabled		24	MHz
$f_{(ECLK)}$	External clock output frequency for ECP module	Pipeline mode enabled		30	MHz
		Pipeline mode disabled		24	MHz
$t_{c(SYS)}$	Cycle time, system clock	Pipeline mode enabled	16.7		ns
		Pipeline mode disabled	41.6		ns
$t_{c(CONFIG)}$	Cycle time, system clock - flash config mode		41.6		ns
$t_{c(ICLK)}$	Cycle time, interface clock	Pipeline mode enabled	33.3		ns
		Pipeline mode disabled	41.6		ns
$t_{c(ECLK)}$	Cycle time, ECP module external clock output	Pipeline mode enabled	33.3		ns
		Pipeline mode disabled	41.6		ns

(1) Not production tested.

(2) $f_{(SYS)} = M \times f_{(OSC)}/R$, where $M = \{8\}$, $R = \{1,2,3,4,5,6,7,8\}$ when PLLDIS = 0. R is the system-clock divider determined by the CLKDIVPRE [2:0] bits in the global control register (GLBCTRL[2:0]) and M is the PLL multiplier determined by the MULT4 bit also in the GLBCTRL register (GLBCTRL.3).

$f_{(SYS)} = f_{(OSC)}/R$, where $R = \{1,2,3,4,5,6,7,8\}$ when PLLDIS = 1.

$f_{(ICLK)} = f_{(SYS)}/X$, where $X = \{1,2,3,4,5,6,7,8,9,10,11,12,13,14,15,16\}$. X is the interface clock divider ratio determined by the PCR0[4:1] bits in the SYS module.

(3) $f_{(ECLK)} = f_{(ICLK)}/N$, where $N = \{1 \text{ to } 256\}$. N is the ECP prescale value defined by the ECPCTRL[7:0] register bits in the ECP module.

(4) Only ZPLL mode is available. FM mode must not be turned on.

(5) Pipeline mode enabled or disabled is determined by the ENPIPE bit (FMREGOPT.0).

(6) Flash Vread must be set to 5 V to achieve maximum system clock frequency.

(7) Operating V_{CC} range for this system clock frequency is 1.81 to 2.05 V.

Table 6-3. Switching Characteristics over Recommended Operating Conditions for External Clocks⁽¹⁾⁽²⁾
⁽³⁾ ⁽⁴⁾

(see Figure 6-3 and Figure 6-4)

PARAMETER	TEST CONDITIONS	MIN	MAX	UNIT
$t_{w(COL)}$	SYSCLK or MCLK ⁽⁵⁾	$0.5t_{c(SYS)} - t_f$		ns
	ICLK: X is even or 1 ⁽⁶⁾	$0.5t_{c(ICLK)} - t_f$		
	ICLK: X is odd and not 1 ⁽⁶⁾	$0.5t_{c(ICLK)} + 0.5t_{c(SYS)} - t_f$		
$t_{w(COH)}$	SYSCLK or MCLK ⁽⁵⁾	$0.5t_{c(SYS)} - t_r$		ns
	ICLK: X is even or 1 ⁽⁶⁾	$0.5t_{c(ICLK)} - t_r$		
	ICLK: X is odd and not 1 ⁽⁶⁾	$0.5t_{c(ICLK)} - 0.5t_{c(SYS)} - t_r$		
$t_{w(EOL)}$	N is even and X is even or odd	$0.5t_{c(ECLK)} - t_f$		ns
	N is odd and X is even	$0.5t_{c(ECLK)} - t_f$		
	N is odd and X is odd and not 1	$0.5t_{c(ECLK)} + 0.5t_{c(SYS)} - t_f$		
$t_{w(EOH)}$	N is even and X is even or odd	$0.5t_{c(ECLK)} - t_r$		ns
	N is odd and X is even	$0.5t_{c(ECLK)} - t_r$		
	N is odd and X is odd and not 1	$0.5t_{c(ECLK)} - 0.5t_{c(SYS)} - t_r$		

- (1) Not production tested.
- (2) X = {1,2,3,4,5,6,7,8,9,10,11,12,13,14,15,16}. X is the interface clock divider ratio determined by the PCR0[4:1] bits in the SYS module.
- (3) N = {1 to 256}. N is the ECP prescale value defined by the ECPCTRL[7:0] register bits in the ECP module.
- (4) CLKOUT/ECLK pulse durations (low/high) are a function of the OSCIN pulse durations when PLLDIS is active.
- (5) Clock source bits are selected as either SYSCLK (CLKCNTL[6:5] = 11 binary) or MCLK (CLKCNTL[6:5] = 10 binary).
- (6) Clock source bits are selected as ICLK (CLKCNTL[6:5] = 01 binary).

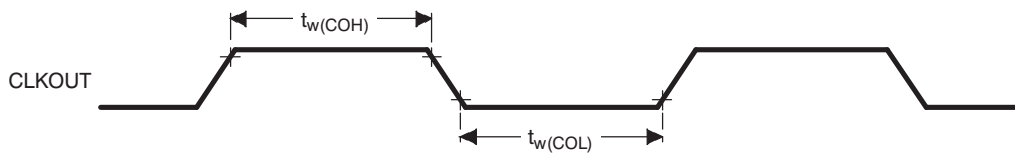

Figure 6-3. CLKOUT Timing Diagram

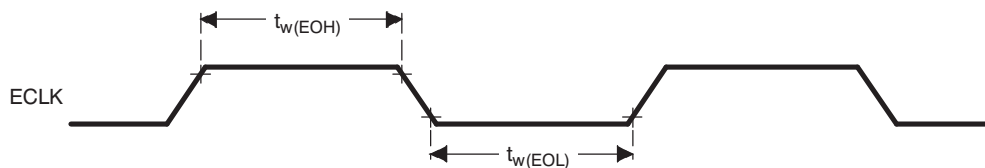

Figure 6-4. ECLK Timing Diagram

6.7 RST and PORRST Timings

Table 6-4. Timing Requirements for PORRST⁽¹⁾

(see Figure 6-5)

		MIN	MAX	UNIT
V _{CCPORL}	V _{CC} low supply level when $\overline{\text{PORRST}}$ must be active during power up		0.6	V
V _{CCPORH}	V _{CC} high supply level when $\overline{\text{PORRST}}$ must remain active during power up and become active during power down	1.5		V
V _{CCIOPORL}	V _{CCIO} low supply level when $\overline{\text{PORRST}}$ must be active during power up		1.1	V
V _{CCIOPORH}	V _{CCIO} high supply level when $\overline{\text{PORRST}}$ must remain active during power up and become active during power down	2.75		V
V _{IL}	Low-level input voltage after V _{CCIO} > V _{CCIOPORH}		0.2 V _{CCIO}	V
V _{IL(PORRST)}	Low-level input voltage of $\overline{\text{PORRST}}$ before V _{CCIO} > V _{CCIOPORL}		0.5	V
t _{su(PORRST)r}	Setup time, $\overline{\text{PORRST}}$ active before V _{CCIO} > V _{CCIOPORL} during power up	0		ms
t _{su(VCCIO)r}	Setup time, V _{CCIO} > V _{CCIOPORL} before V _{CC} > V _{CCPORL}	0		ms
t _{h(PORRST)r}	Hold time, $\overline{\text{PORRST}}$ active after V _{CC} > V _{CCPORH}	1		ms
t _{su(PORRST)f}	Setup time, $\overline{\text{PORRST}}$ active before V _{CC} ≤ V _{CCPORH} during power down	8		μs
t _{h(PORRST)rio}	Hold time, $\overline{\text{PORRST}}$ active after V _{CC} > V _{CCIOPORH}	1		ms
t _{h(PORRST)d}	Hold time, $\overline{\text{PORRST}}$ active after V _{CC} < V _{CCPORL}	0		ms
t _{su(PORRST)rio}	Setup time, $\overline{\text{PORRST}}$ active before V _{CC} ≤ V _{CCIOPORH} during power down	0		ns
t _{su(VCCIO)f}	Setup time, V _{CC} < V _{CCPORL} before V _{CCIO} < V _{CCIOPORL}	0		ns

(1) Not production tested.

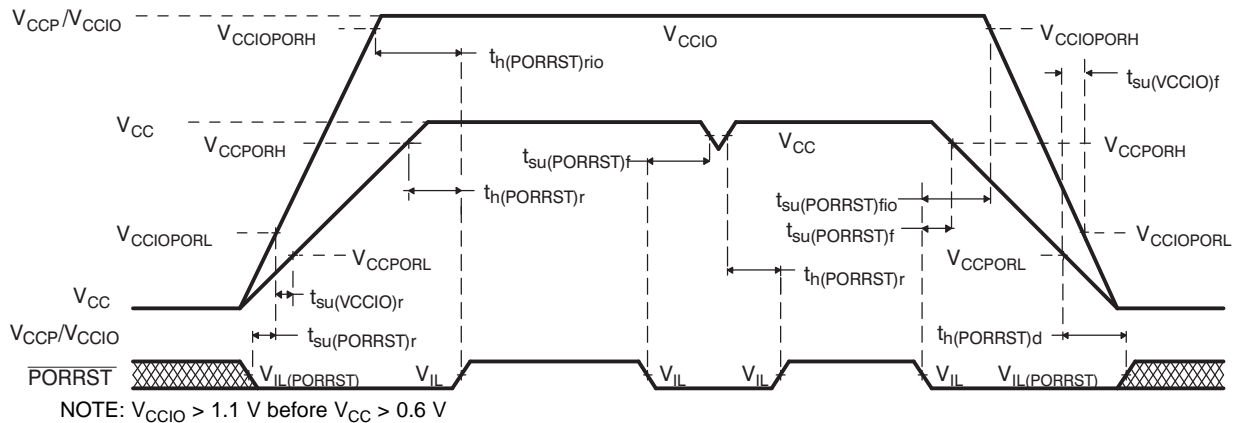

Figure 6-5. PORRST Timing Diagram

Table 6-5. Switching Characteristics over Recommended Operating Conditions for RST⁽¹⁾ (2)

PARAMETER		MIN	MAX	UNIT
t _{v(RST)}	Valid time, $\overline{\text{RST}}$ active after $\overline{\text{PORRST}}$ inactive	4112t _{c(OSC)}		ns
	Valid time, $\overline{\text{RST}}$ active (all others)	8t _{c(SYS)}		
t _{fsu}	Flash start up time, from $\overline{\text{RST}}$ inactive to fetch of first instruction from flash (flash pump stabilization time)	836t _{c(OSC)}		ns

(1) Not production tested.

(2) Specified values do NOT include rise/fall times. For rise and fall timings, see the "switching characteristics for output timings versus load capacitance" table.

6.8 JTAG Scan Interface Timing

Table 6-6. JTAG Clock Specification 10-MHz and 50-pF Load on TDO Output⁽¹⁾

		MIN	MAX	UNIT
$t_{c(JTAG)}$	Cycle time, JTAG low and high period	50		ns
$t_{su(TDI/TMS - TCKr)}$	Setup time, TDI, TMS before TCK rise (TCKr)	15		ns
$t_h(TCKr - TDI/TMS)$	Hold time, TDI, TMS after TCKr	15		ns
$t_h(TCKf - TDO)$	Hold time, TDO after TCKf	10		ns
$t_d(TCKf - TDO)$	Delay time, TDO valid after TCK fall (TCKf)		45	ns

(1) Not production tested.

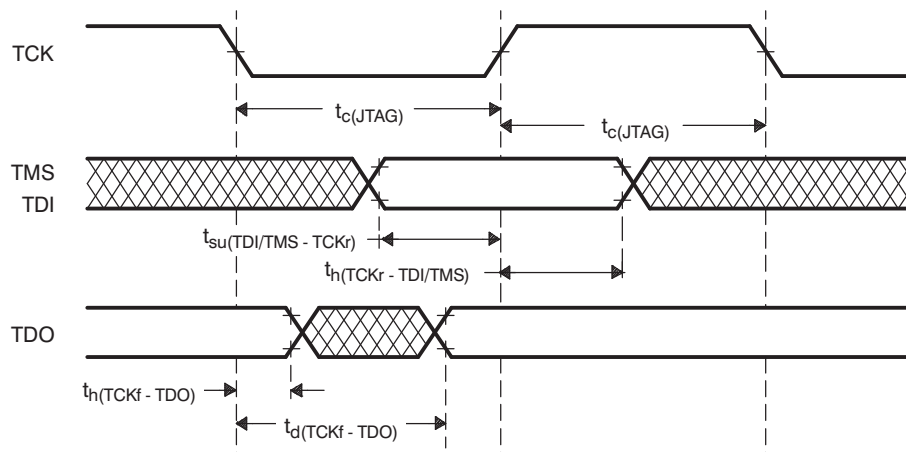

Figure 6-6. JTAG Scan Timings

6.9 Output Timings

Table 6-7. Switching Characteristics for Output Timings versus Load Capacitance (C_L)⁽¹⁾

(see Figure 6-7)

PARAMETER		MIN	MAX	UNIT	
t_r	Rise time, AWD, CLKOUT, $\overline{\text{TDI}}$, TDO, TMS, TMS2	$C_L = 15 \text{ pF}$	0.5	2.5	ns
		$C_L = 50 \text{ pF}$	1.5	5.0	
		$C_L = 100 \text{ pF}$	3.0	9.0	
		$C_L = 150 \text{ pF}$	4.5	12.5	
t_f	Fall time, AWD, CLKOUT, $\overline{\text{TDI}}$, TDO, TMS, TMS2	$C_L = 15 \text{ pF}$	0.5	2.5	ns
		$C_L = 50 \text{ pF}$	1.5	5.0	
		$C_L = 100 \text{ pF}$	3.0	9.0	
		$C_L = 150 \text{ pF}$	4.5	12.5	
t_r	Rise time, $\overline{\text{RST}}$	$C_L = 15 \text{ pF}$	2.5	8	ns
		$C_L = 50 \text{ pF}$	5	14	
		$C_L = 100 \text{ pF}$	9	23	
		$C_L = 150 \text{ pF}$	13	32	
t_r	Rise time, 4-mA, 5-V tolerant pins	$C_L = 15 \text{ pF}$	3	10	ns
		$C_L = 50 \text{ pF}$	3.5	12	
		$C_L = 100 \text{ pF}$	7	21	
		$C_L = 150 \text{ pF}$	9	28	
t_f	Fall time, 4-mA, 5-V tolerant pins	$C_L = 15 \text{ pF}$	2	8	ns
		$C_L = 50 \text{ pF}$	2.5	9	
		$C_L = 100 \text{ pF}$	8	25	
		$C_L = 150 \text{ pF}$	11	35	
t_r	Rise time, all other output pins	$C_L = 15 \text{ pF}$	2.5	10	ns
		$C_L = 50 \text{ pF}$	6.0	25	
		$C_L = 100 \text{ pF}$	12	45	
		$C_L = 150 \text{ pF}$	18	65	
t_f	Fall time, all other output pins	$C_L = 15 \text{ pF}$	3	10	ns
		$C_L = 50 \text{ pF}$	8.5	25	
		$C_L = 100 \text{ pF}$	16	45	
		$C_L = 150 \text{ pF}$	23	65	

(1) Not production tested.

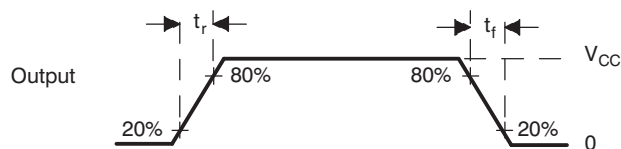

Figure 6-7. CMOS-Level Outputs

6.10 Input Timings

Table 6-8. Timing Requirements for Input Timings⁽¹⁾⁽²⁾

(see [Figure 6-8](#))

	MIN	MAX	UNIT
t_{pw} Input minimum pulse width	$t_{c(ICLK)} + 10$		ns

(1) Not production tested.

(2) $t_{c(ICLK)}$ = interface clock cycle time = $1/f_{(ICLK)}$

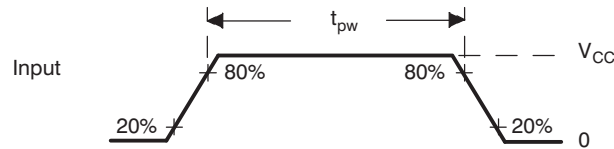

Figure 6-8. CMOS-Level Inputs

6.11 Flash Timings

Table 6-9. Timing Requirements for Program Flash⁽¹⁾⁽²⁾

	MIN	TYP	MAX	UNIT
$t_{prog(16-bit)}$ Half word (16-bit) programming time	4	16	200	μ s
$t_{prog(Total)}$ 1MB programming time ⁽³⁾		8	32	s
$t_{erase(sector)}$ Sector erase time, $T_A = -40^\circ\text{C}$ to 150°C		1.7		s
t_{wec} Write/erase cycles at $T_A = -40^\circ\text{C}$ to 85°C	50000			cycles
$t_{fp(RST)}$ Flash pump settling time from \overline{RST} to SLEEP		$167t_{c(SYS)}$		ns
$t_{fp(SLEEP)}$ Initial flash pump settling time from SLEEP to STANDBY		$167t_{c(SYS)}$		ns
$t_{fp(STANDBY)}$ Initial flash pump settling time from STANDBY to ACTIVE		$84t_{c(SYS)}$		ns

(1) Not production tested.

(2) For more detailed information on the flash core sectors, see the *flash program and erase* section of this data sheet.

(3) The 1MB programming time includes overhead of state machine.

6.12 SPIn Master Mode Timing Parameters

Table 6-10. SPIn Master Mode External Timing Parameters

(CLOCK PHASE = 0, SPInCLK = output, SPInSIMO = output, and SPInSOMI = input)^{(1)(2) (3) (4)} (see [Figure 6-9](#))

NO.		MIN	MAX	UNIT
1	$t_{c(SPC)M}$ Cycle time, SPInCLK ⁽⁵⁾	100	$256t_{c(ICLK)}$	ns
2 ⁽⁶⁾	$t_{w(SPCH)M}$ Pulse duration, SPInCLK high (clock polarity = 0)	$0.5t_{c(SPC)M} - t_r$	$0.5t_{c(SPC)M} + 5$	
	$t_{w(SPCL)M}$ Pulse duration, SPInCLK low (clock polarity = 1)	$0.5t_{c(SPC)M} - t_f$	$0.5t_{c(SPC)M} + 5$	
3 ⁽⁶⁾	$t_{w(SPCL)M}$ Pulse duration, SPInCLK low (clock polarity = 0)	$0.5t_{c(SPC)M} - t_f$	$0.5t_{c(SPC)M} + 5$	
	$t_{w(SPCH)M}$ Pulse duration, SPInCLK high (clock polarity = 1)	$0.5t_{c(SPC)M} - t_r$	$0.5t_{c(SPC)M} + 5$	
4 ⁽⁶⁾	$t_{d(SPCH-SIMO)M}$ Delay time, SPInCLK high to SPInSIMO valid (clock polarity = 0)		10	
	$t_{d(SPCL-SIMO)M}$ Delay time, SPInCLK low to SPInSIMO valid (clock polarity = 1)		10	
5 ⁽⁶⁾	$t_{v(SPCL-SIMO)M}$ Valid time, SPInSIMO data valid after SPInCLK low (clock polarity = 0)	$t_{c(SPC)M} - 5 - t_f$		
	$t_{v(SPCH-SIMO)M}$ Valid time, SPInSIMO data valid after SPInCLK high (clock polarity = 1)	$t_{c(SPC)M} - 5 - t_r$		
6 ⁽⁶⁾	$t_{su(SOMI-SPCL)M}$ Setup time, SPInSOMI before SPInCLK low (clock polarity = 0)	6		
	$t_{su(SOMI-SPCH)M}$ Setup time, SPInSOMI before SPInCLK high (clock polarity = 1)	6		
7 ⁽⁶⁾	$t_{v(SPCL-SOMI)M}$ Valid time, SPInSOMI data valid after SPInCLK low (clock polarity = 0)	4		
	$t_{v(SPCH-SOMI)M}$ Valid time, SPInSOMI data valid after SPInCLK high (clock polarity = 1)	4		

- (1) Not production tested.
- (2) The MASTER bit (SPInCTRL2.3) is set and the CLOCK PHASE bit (SPInCTRL2.0) is cleared.
- (3) $t_{c(ICLK)}$ = interface clock cycle time = $1 / f_{(ICLK)}$
- (4) For rise and fall timings, see the "Switching Characteristics for Output Timings versus Load Capacitance" table.
- (5) When the SPI is in master mode, the following must be true:
For PS values from 1 to 255: $t_{c(SPC)M} \geq (PS + 1)t_{c(ICLK)} \geq 100$ ns, where PS is the prescale value set in the SPInCTL1[12:5] register bits.
For PS values of 0: $t_{c(SPC)M} = 2t_{c(ICLK)} \geq 100$ ns.
- (6) The active edge of the SPInCLK signal referenced is controlled by the CLOCK POLARITY bit (SPInCTRL2.1).

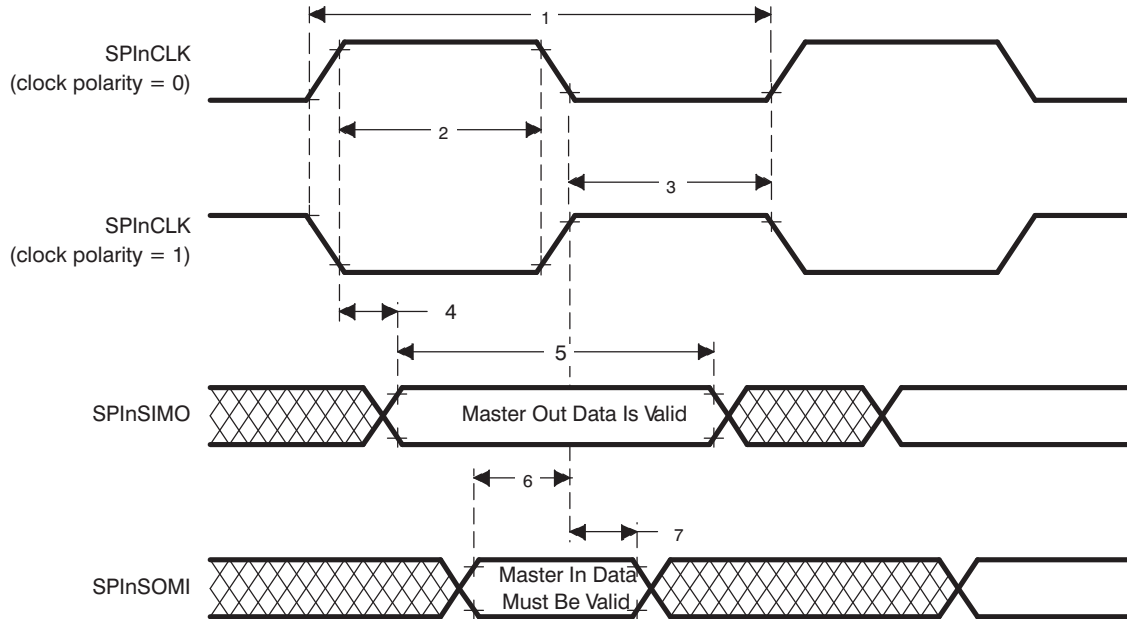

Figure 6-9. SPIn Master Mode External Timing (CLOCK PHASE = 0)

Table 6-11. SPIn Master Mode External Timing Parameters⁽¹⁾

(CLOCK PHASE = 1, SPInCLK = output, SPInSIMO = output, and SPInSOMI = input)^{(2) (3) (4)} (see Figure 6-10)

NO.			MIN	MAX	UNIT
1	$t_{c(SPC)M}$	Cycle time, SPInCLK ⁽⁵⁾	100	$256t_{c(ICLK)}$	ns
2 ⁽⁶⁾	$t_{w(SPCH)M}$	Pulse duration, SPInCLK high (clock polarity = 0)	$0.5t_{c(SPC)M} - t_r$	$0.5t_{c(SPC)M} + 5$	
	$t_{w(SPCL)M}$	Pulse duration, SPInCLK low (clock polarity = 1)	$0.5t_{c(SPC)M} - t_f$	$0.5t_{c(SPC)M} + 5$	
3 ⁽⁶⁾	$t_{w(SPCL)M}$	Pulse duration, SPInCLK low (clock polarity = 0)	$0.5t_{c(SPC)M} - t_f$	$0.5t_{c(SPC)M} + 5$	
	$t_{w(SPCH)M}$	Pulse duration, SPInCLK high (clock polarity = 1)	$0.5t_{c(SPC)M} - t_r$	$0.5t_{c(SPC)M} + 5$	
4 ⁽⁶⁾	$t_{v(SIMO-SPCH)M}$	Valid time, SPInCLK high after SPInSIMO data valid (clock polarity = 0)	$0.5t_{c(SPC)M} - 10$		
	$t_{v(SIMO-SPCL)M}$	Valid time, SPInCLK low after SPInSIMO data valid (clock polarity = 1)	$0.5t_{c(SPC)M} - 10$		
5 ⁽⁶⁾	$t_{v(SPCH-SIMO)M}$	Valid time, SPInSIMO data valid after SPInCLK high (clock polarity = 0)	$0.5t_{c(SPC)M} - 5 - t_r$		
	$t_{v(SPCL-SIMO)M}$	Valid time, SPInSIMO data valid after SPInCLK low (clock polarity = 1)	$0.5t_{c(SPC)M} - 5 - t_f$		
6 ⁽⁶⁾	$t_{su(SOMI-SPCH)M}$	Setup time, SPInSOMI before SPInCLK high (clock polarity = 0)	6		
	$t_{su(SOMI-SPCL)M}$	Setup time, SPInSOMI before SPInCLK low (clock polarity = 1)	6		
7 ⁽⁶⁾	$t_{v(SPCH-SOMI)M}$	Valid time, SPInSOMI data valid after SPInCLK high (clock polarity = 0)	4		
	$t_{v(SPCL-SOMI)M}$	Valid time, SPInSOMI data valid after SPInCLK low (clock polarity = 1)	4		

- (1) Not production tested.
- (2) The MASTER bit (SPInCTRL2.3) is set and the CLOCK PHASE bit (SPInCTRL2.0) is set.
- (3) $t_{c(ICLK)}$ = interface clock cycle time = $1/f_{(ICLK)}$
- (4) For rise and fall timings, see the "Switching Characteristics for Output Timings versus Load Capacitance" table.
- (5) When the SPI is in master mode, the following must be true:
For PS values from 1 to 255: $t_{c(SPC)M} \geq (PS + 1)t_{c(ICLK)} \geq 100$ ns, where PS is the prescale value set in the SPInCTL1[12:5] register bits.
For PS values of 0: $t_{c(SPC)M} = 2t_{c(ICLK)} \geq 100$ ns.
- (6) The active edge of the SPInCLK signal referenced is controlled by the CLOCK POLARITY bit (SPInCTRL2.1).

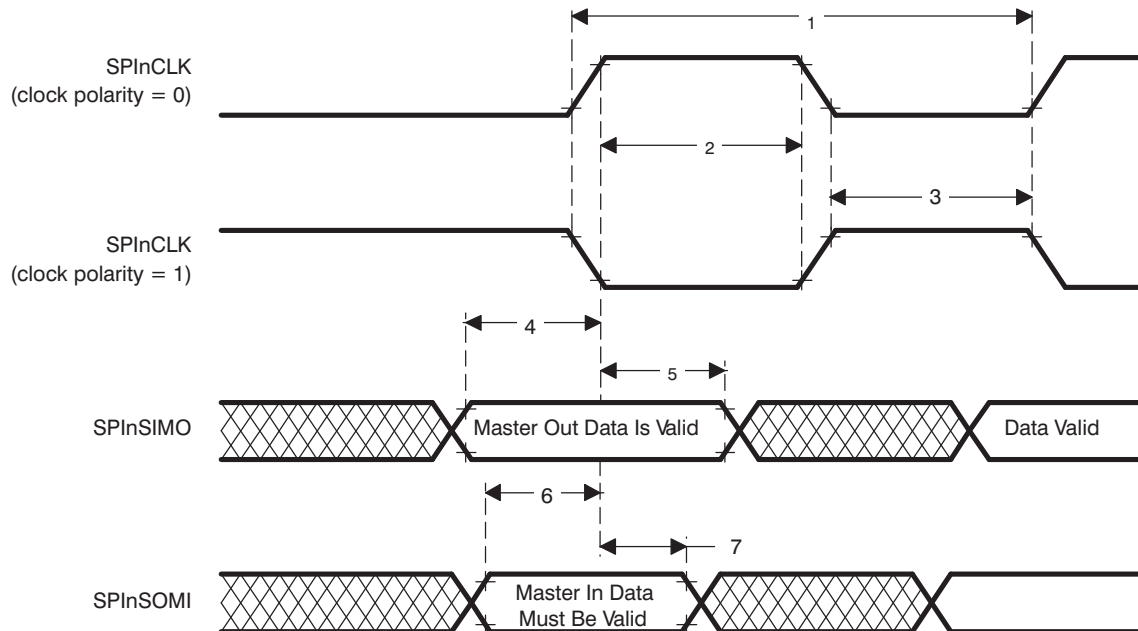

Figure 6-10. SPIn Master Mode External Timing (CLOCK PHASE = 1)

6.13 SPIn Slave Mode Timing Parameters

Table 6-12. SPIn Slave Mode External Timing Parameters⁽¹⁾

(CLOCK PHASE = 0, SPInCLK = input, SPInSIMO = input, and SPInSOMI = output)^{(2) (3) (4) (5)} (see Figure 6-11)

NO.			MIN	MAX	UNIT
1	$t_{c(SPC)S}$	Cycle time, SPInCLK ⁽⁶⁾	100	$256t_{c(ICLK)}$	ns
2 ⁽⁷⁾	$t_{w(SPCH)S}$	Pulse duration, SPInCLK high (clock polarity = 0)	$0.5t_{c(SPC)S} - 0.25t_{c(ICLK)}$	$0.5t_{c(SPC)S} + 0.25t_{c(ICLK)}$	
	$t_{w(SPCL)S}$	Pulse duration, SPInCLK low (clock polarity = 1)	$0.5t_{c(SPC)S} - 0.25t_{c(ICLK)}$	$0.5t_{c(SPC)S} + 0.25t_{c(ICLK)}$	
3 ⁽⁷⁾	$t_{w(SPCL)S}$	Pulse duration, SPInCLK low (clock polarity = 0)	$0.5t_{c(SPC)S} - 0.25t_{c(ICLK)}$	$0.5t_{c(SPC)S} + 0.25t_{c(ICLK)}$	
	$t_{w(SPCH)S}$	Pulse duration, SPInCLK high (clock polarity = 1)	$0.5t_{c(SPC)S} - 0.25t_{c(ICLK)}$	$0.5t_{c(SPC)S} + 0.25t_{c(ICLK)}$	
4 ⁽⁷⁾	$t_{d(SPCH-SOMI)S}$	Delay time, SPInCLK high to SPInSOMI valid (clock polarity = 0)		$6 + t_r$	
	$t_{d(SPCL-SOMI)S}$	Delay time, SPInCLK low to SPInSOMI valid (clock polarity = 1)		$6 + t_f$	
5 ⁽⁷⁾	$t_{v(SPCH-SOMI)S}$	Valid time, SPInSOMI data valid after SPInCLK high (clock polarity = 0)	$t_{c(SPC)S} - 6 - t_r$		
	$t_{v(SPCL-SOMI)S}$	Valid time, SPInSOMI data valid after SPInCLK low (clock polarity = 1)	$t_{c(SPC)S} - 6 - t_f$		
6 ⁽⁷⁾	$t_{su(SIMO-SPCL)S}$	Setup time, SPInSIMO before SPInCLK low (clock polarity = 0)	6		
	$t_{su(SIMO-SPCH)S}$	Setup time, SPInSIMO before SPInCLK high (clock polarity = 1)	6		
7 ⁽⁷⁾	$t_{v(SPCL-SIMO)S}$	Valid time, SPInSIMO data valid after SPInCLK low (clock polarity = 0)	6		
	$t_{v(SPCH-SIMO)S}$	Valid time, SPInSIMO data valid after SPInCLK high (clock polarity = 1)	6		

(1) Not production tested.

(2) The MASTER bit (SPInCTRL2.3) is cleared and the CLOCK PHASE bit (SPInCTRL2.0) is cleared.

(3) If the SPI is in slave mode, the following must be true: $t_{c(SPC)S} \geq (PS + 1)t_{c(ICLK)}$, where PS = prescale value set in SPInCTL1[12:5].

(4) For rise and fall timings, see the "Switching Characteristics for Output Timings versus Load Capacitance" table.

(5) $t_{c(ICLK)}$ = interface clock cycle time = $1/f_{(ICLK)}$

(6) When the SPIn is in slave mode, the following must be true:

For PS values from 1 to 255: $t_{c(SPC)S} \geq (PS + 1)t_{c(ICLK)} \geq 100$ ns, where PS is the prescale value set in the SPInCTL1[12:5] register bits.

For PS values of 0: $t_{c(SPC)S} = 2t_{c(ICLK)} \geq 100$ ns.

(7) The active edge of the SPInCLK signal referenced is controlled by the CLOCK POLARITY bit (SPInCTRL2.1).

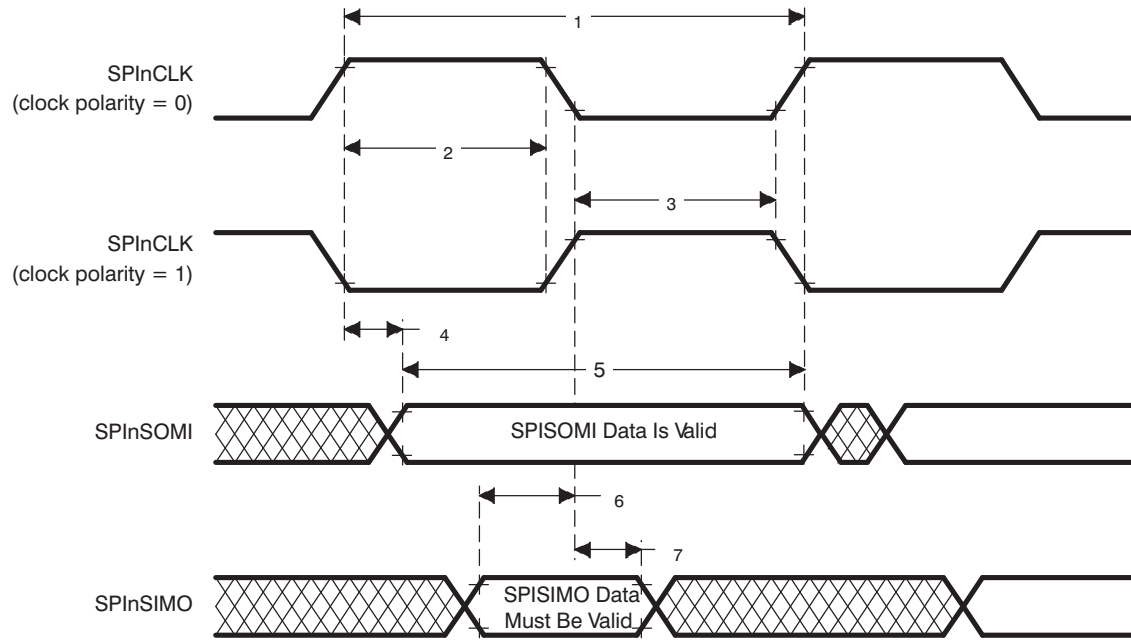

Figure 6-11. SPIn Slave Mode External Timing (CLOCK PHASE = 0)

Table 6-13. SPIn Slave Mode External Timing Parameters⁽¹⁾

(CLOCK PHASE = 1, SPInCLK = input, SPInSIMO = input, and SPInSOMI = output)^{(2) (3) (4) (5)} (see Figure 6-12)

NO.			MIN	MAX	UNIT
1	$t_{c(SPC)S}$	Cycle time, SPInCLK ⁽⁶⁾	100	$256t_{c(ICLK)}$	ns
2 ⁽⁷⁾	$t_{w(SPCH)S}$	Pulse duration, SPInCLK high (clock polarity = 0)	$0.5t_{c(SPC)S} - 0.25t_{c(ICLK)}$	$0.5t_{c(SPC)S} + 0.25t_{c(ICLK)}$	
	$t_{w(SPCL)S}$	Pulse duration, SPInCLK low (clock polarity = 1)	$0.5t_{c(SPC)S} - 0.25t_{c(ICLK)}$	$0.5t_{c(SPC)S} + 0.25t_{c(ICLK)}$	
3 ⁽⁷⁾	$t_{w(SPCL)S}$	Pulse duration, SPInCLK low (clock polarity = 0)	$0.5t_{c(SPC)S} - 0.25t_{c(ICLK)}$	$0.5t_{c(SPC)S} + 0.25t_{c(ICLK)}$	
	$t_{w(SPCH)S}$	Pulse duration, SPInCLK high (clock polarity = 1)	$0.5t_{c(SPC)S} - 0.25t_{c(ICLK)}$	$0.5t_{c(SPC)S} + 0.25t_{c(ICLK)}$	
4 ⁽⁷⁾	$t_{v(SOMI-SPCH)S}$	Valid time, SPInCLK high after SPInSOMI data valid (clock polarity = 0)	$0.5t_{c(SPC)S} - 6 - t_r$		
	$t_{v(SOMI-SPCL)S}$	Valid time, SPInCLK low after SPInSOMI data valid (clock polarity = 1)	$0.5t_{c(SPC)S} - 6 - t_f$		
5 ⁽⁷⁾	$t_{v(SPCH-SOMI)S}$	Valid time, SPInSOMI data valid after SPInCLK high (clock polarity = 0)	$0.5t_{c(SPC)S} - 6 - t_r$		
	$t_{v(SPCL-SOMI)S}$	Valid time, SPInSOMI data valid after SPInCLK low (clock polarity = 1)	$0.5t_{c(SPC)S} - 6 - t_f$		
6 ⁽⁷⁾	$t_{su(SIMO-SPCH)S}$	Setup time, SPInSIMO before SPInCLK high (clock polarity = 0)	6		
	$t_{su(SIMO-SPCL)S}$	Setup time, SPInSIMO before SPInCLK low (clock polarity = 1)	6		
7 ⁽⁷⁾	$t_{v(SPCH-SIMO)S}$	Valid time, SPInSIMO data valid after SPInCLK high (clock polarity = 0)	6		
	$t_{v(SPCL-SIMO)S}$	Valid time, SPInSIMO data valid after SPInCLK low (clock polarity = 1)	6		

- (1) Not production tested.
- (2) The MASTER bit (SPInCTRL2.3) is cleared and the CLOCK PHASE bit (SPInCTRL2.0) is set.
- (3) If the SPI is in slave mode, the following must be true: $t_{c(SPC)S} \geq (PS + 1)t_{c(ICLK)}$, where PS = prescale value set in SPInCTL1[12:5].
- (4) For rise and fall timings, see the "Switching Characteristics for Output Timings versus Load Capacitance" table.
- (5) $t_{c(ICLK)}$ = interface clock cycle time = $1/f_{(ICLK)}$
- (6) When the SPIn is in slave mode, the following must be true:
For PS values from 1 to 255: $t_{c(SPC)S} \geq (PS + 1)t_{c(ICLK)} \geq 100$ ns, where PS is the prescale value set in the SPInCTL1[12:5] register bits.
For PS values of 0: $t_{c(SPC)S} = 2t_{c(ICLK)} \geq 100$ ns.
- (7) The active edge of the SPInCLK signal referenced is controlled by the CLOCK POLARITY bit (SPInCTRL2.1).

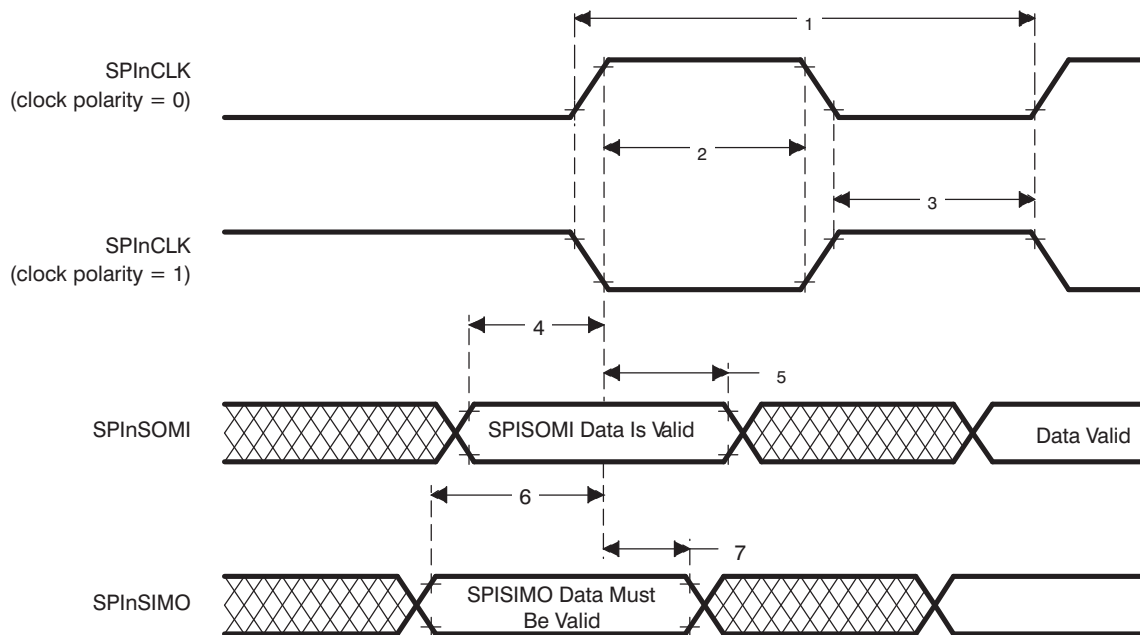

Figure 6-12. SPIn Slave Mode External Timing (CLOCK PHASE = 1)

6.14 SCIN Isosynchronous Mode Timings - Internal Clock

Table 6-14. Timing Requirements for Internal Clock SCIN Isosynchronous Mode⁽¹⁾⁽²⁾⁽³⁾⁽⁴⁾

(see Figure 6-13)

		(BAUD + 1) IS EVEN OR BAUD = 0		(BAUD + 1) IS ODD AND BAUD ≠ 0		UNIT
		MIN	MAX	MIN	MAX	
$t_{c(SCC)}$	Cycle time, SCInCLK	$2t_{c(ICLK)}$	$2^{24} t_{c(ICLK)}$	$3t_{c(ICLK)}$	$(2^{24} - 1) t_{c(ICLK)}$	ns
$t_w(SCCL)$	Pulse duration, SCInCLK low	$0.5t_{c(SCC)} - t_f$	$0.5t_{c(SCC)} + 5$	$0.5t_{c(SCC)} + 0.5t_{c(ICLK)} - t_f$	$0.5t_{c(SCC)} + 0.5t_{c(ICLK)}$	ns
$t_w(SCCH)$	Pulse duration, SCInCLK high	$0.5t_{c(SCC)} - t_f$	$0.5t_{c(SCC)} + 5$	$0.5t_{c(SCC)} - 0.5t_{c(ICLK)} - t_f$	$0.5t_{c(SCC)} - 0.5t_{c(ICLK)}$	ns
$t_d(SCCH-TXV)$	Delay time, SCInCLK high to SCInTX valid		10		10	ns
$t_v(TX)$	Valid time, SCInTX data after SCInCLK low	$t_{c(SCC)} - 10$		$t_{c(SCC)} - 10$		ns
$t_{su}(RX-SCCL)$	Setup time, SCInRX before SCInCLK low	$t_{c(ICLK)} + t_f + 20$		$t_{c(ICLK)} + t_f + 20$		ns
$t_v(SCCL-RX)$	Valid time, SCInRX data after SCInCLK low	$-t_{c(ICLK)} + t_f + 20$		$-t_{c(ICLK)} + t_f + 20$		ns

- (1) Not production tested.
- (2) BAUD = 24-bit concatenated value formed by the SCI[H,M,L]BAUD registers.
- (3) $t_{c(ICLK)}$ = interface clock cycle time = $1 / f_{(ICLK)}$
- (4) For rise and fall timings, see the "switching characteristics for output timings versus load capacitance" table.

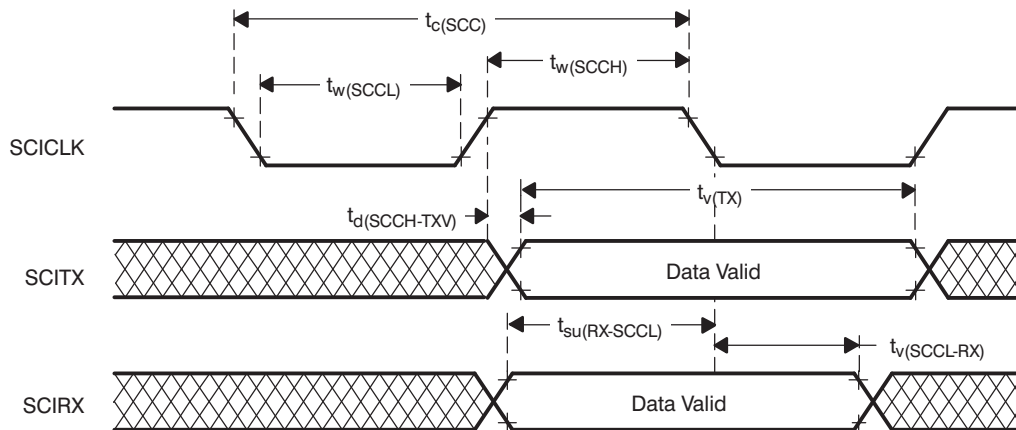

NOTE: Data transmission/reception characteristics for isosynchronous mode with internal clocking are similar to the asynchronous mode. Data transmission occurs on the SCICLK rising edge, and data reception occurs on the SCICLK falling edge.

Figure 6-13. SCIn Isosynchronous Mode Timing Diagram for Internal Clock

6.15 SCIN Isosynchronous Mode Timings - External Clock

Table 6-15. Timing Requirements for External Clock SCIN Isosynchronous Mode^{(1)(2) (3)}

(see [Figure 6-14](#))

		MIN	MAX	UNIT
$t_{c(SCC)}$	Cycle time, SCInCLK ⁽⁴⁾	$8t_{c(ICLK)}$		ns
$t_w(SCCH)$	Pulse duration, SCInCLK high	$0.5t_{c(SCC)} - 0.25t_{c(ICLK)}$	$0.5t_{c(SCC)} + 0.25t_{c(ICLK)}$	ns
$t_w(SCCL)$	Pulse duration, SCInCLK low	$0.5t_{c(SCC)} - 0.25t_{c(ICLK)}$	$0.5t_{c(SCC)} + 0.25t_{c(ICLK)}$	ns
$t_d(SCCH-TXV)$	Delay time, SCInCLK high to SCInTX valid	$2t_{c(ICLK)} + 12 + t_r$		ns
$t_v(TX)$	Valid time, SCInTX data after SCInCLK low	$2t_{c(SCC)} - 10$		ns
$t_{su}(RX-SCCL)$	Setup time, SCInRX before SCInCLK low	0		ns
$t_v(SCCL-RX)$	Valid time, SCInRX data after SCInCLK low	$2t_{c(ICLK)} + 10$		ns

- (1) Not production tested.
- (2) $t_{c(ICLK)}$ = interface clock cycle time = $1/f_{(ICLK)}$
- (3) For rise and fall timings, see the "switching characteristics for output timings versus load capacitance" table.
- (4) When driving an external SCInCLK, the following must be true: $t_{c(SCC)} \geq 8t_{c(ICLK)}$.

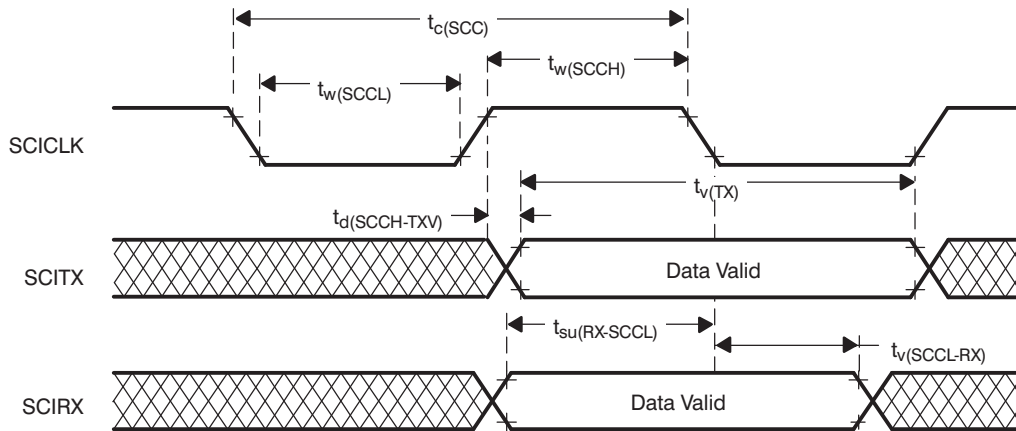

- A. Data transmission / reception characteristics for isosynchronous mode with external clocking are similar to the asynchronous mode. Data transmission occurs on the SCICLK rising edge, and data reception occurs on the SCICLK falling edge.

Figure 6-14. SCIN Isosynchronous Mode Timing Diagram for External Clock

6.16 I²C Timing

Table 6-16 Assumes testing over recommended operating conditions.

Table 6-16. I²C Signals (SDA and SCL) Switching Characteristics⁽¹⁾⁽²⁾

PARAMETER		STANDARD MODE		FAST MODE		UNIT
		MIN	MAX	MIN	MAX	
t _{c(I2CCLK)}	Cycle time, I2C module clock	75	150	75	150	ns
t _{c(SCL)}	Cycle time, SCL	10		2.5		µs
t _{su(SCLH-SDAL)}	Setup time, SCL high before SDA low (for a repeated START condition)	4.7		0.6		µs
t _{h(SCLL-SDAL)}	Hold time, SCL low after SDA low (for a repeated START condition)	4		0.6		µs
t _{w(SCLL)}	Pulse duration, SCL low	4.7		1.3		µs
t _{w(SCLH)}	Pulse duration, SCL high	4		0.6		µs
t _{su(SDA-SCLH)}	Setup time, SDA valid before SCL high	250		100		ns
t _{h(SDA-SCLL)}	Hold time, SDA valid after SCL low	0	3.45 ⁽³⁾	0	0.9	µs
t _{w(SDAH)}	Pulse duration, SDA high between STOP and START conditions	4.7		1.3		µs
t _{r(SCL)}	Rise time, SCL		1000	20+0.1C _b ⁽⁴⁾	300	ns
t _{r(SDA)}	Rise time, SDA		1000	20+0.1C _b ⁽⁴⁾	300	ns
t _{f(SCL)}	Fall time, SCL		300	20+0.1C _b ⁽⁴⁾	300	ns
t _{f(SDA)}	Fall time, SDA		300	20+0.1C _b ⁽⁴⁾	300	ns
t _{su(SCLH-SDAH)}	Setup time, SCL high before SDA high (for STOP condition)	4.0		0.6		µs
t _{w(SP)}	Pulse duration, spike (must be suppressed)			0	50	ns
C _b ⁽⁴⁾	Capacitive load for each bus line		400		400	pF

- (1) Not production tested.
- (2) The I2C pins SDA and SCL do not feature fail-safe I/O buffers. These pins could potentially draw current when the device is powered down.
- (3) The maximum t_{h(SDA-SCLL)} for I2C bus devices needs to be met only if the device does not stretch the low period (t_{w(SCLL)}) of the SCL signal.
- (4) C_b = The total capacitance of one bus line in pF. If mixed with HS=mode devices, faster fall-times are allowed.

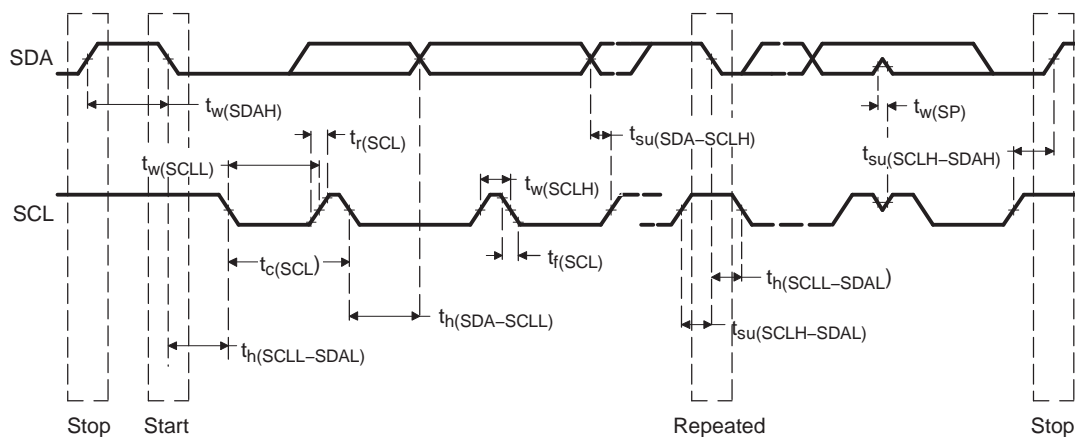

- A. A device must internally provide a hold time of at least 300 ns for the SDA signal (referred to the V_{IHmin} of the SCL signal) to bridge the undefined region of the falling edge of SCL.
- B. The maximum t_{h(SDA-SCLL)} needs only be met if the device does not stretch the LOW period (t_{w(SCLL)}) of the SCL signal.
- C. A fast-mode I2C-bus device can be used in a standard-mode I2C-bus system, but the requirement t_{su(SDA-SCLH)} ≥ 250 ns must then be met. This will automatically be the case if the device does not stretch the LOW period of the SCL signal. If such a device does stretch the LOW period of the SCL signal, it must output the next data bit to the SDA line t_{r max} + t_{su(SDA-SCLH)}.
- D. C_b = total capacitance of one bus line in pF. If mixed with HS=mode devices, faster fall-times are allowed.

Figure 6-15. I²C Timings

6.17 Standard Can Controller (SCC) Mode Timings

Table 6-17. Dynamic Characteristics for the CANSTX and CANSRX Pins⁽¹⁾

PARAMETER		MIN	MAX	UNIT
t_d (CANSTX)	Delay time, transmit shift register to CANSTX pin ⁽²⁾		15	ns
t_d (CANSRX)	Delay time, CANSRX pin to receive shift register		5	ns

(1) Not production tested.

(2) These values do not include the rise/fall times of the output buffer.

6.18 Expansion Bus Module Timing

Table 6-18. Expansion Bus Timing Parameters⁽¹⁾
 $-55^{\circ}\text{C} \leq T_A \leq 220^{\circ}\text{C}$, $3.0\text{ V} \leq V_{CC} \leq 3.6\text{ V}$ (see [Figure 6-16](#) and [Figure 6-17](#))

		MIN	MAX	UNIT
$t_{c}(\text{CO})$	Cycle time, CLKOUT	20.8		ns
$t_{d}(\text{COH-EBADV})$	Delay time, CLKOUT high to EBADDR valid		21.4	ns
$t_{h}(\text{COH-EBADIV})$	Hold time, EBADDR invalid after CLKOUT high		12.4	ns
$t_{d}(\text{COH-EBOE})$	Delay time, CLKOUT high to $\overline{\text{EBOE}}$ fall		11.4	ns
$t_{h}(\text{COH-EBOEH})$	Hold time, $\overline{\text{EBOE}}$ rise after CLKOUT high		11.4	ns
$t_{d}(\text{COL-EBWR})$	Delay time, CLKOUT low to write strobe ($\overline{\text{EBWR}}$) low		11.3	ns
$t_{h}(\text{COL-EBWRH})$	Hold time, $\overline{\text{EBWR}}$ high after CLKOUT low		11.6	ns
$t_{su}(\text{EBRDATV-COH})$	Setup time, EBDATA valid before CLKOUT high (READ) ⁽²⁾	15.2		ns
$t_{h}(\text{COH-EBRDATIV})$	Hold time, EBDATA invalid after CLKOUT high (READ)		(-14.7)	ns
$t_{d}(\text{COL-EBWDATV})$	Delay time, CLKOUT low to EBDATA valid (WRITE) ⁽³⁾		16.1	ns
$t_{h}(\text{COL-EBWDATIV})$	Hold time, EBDATA invalid after CLKOUT low (WRITE)		14.7	ns
SECONDARY TIMES				
$t_{d}(\text{COH-EBCS0})$	Delay, CLKOUT high to $\overline{\text{EBCS0}}$ fall		13.6	ns
$t_{h}(\text{COH-EBCS0H})$	Hold, $\overline{\text{EBCS0}}$ rise after CLKOUT high		13.2	ns
$t_{su}(\text{COH-EBHOLDL})$	Setup time, $\overline{\text{EBHOLD}}$ low to CLKOUT high ⁽²⁾	10.9		ns
$t_{su}(\text{COH-EBHOLDH})$	Setup time, $\overline{\text{EBHOLD}}$ high to CLKOUT high ⁽²⁾	10.5		ns

(1) Not production tested.

(2) Setup time is the minimum time under worst case conditions. Data with less setup time will not work.

(3) Valid after CLKOUT goes low for write cycles.

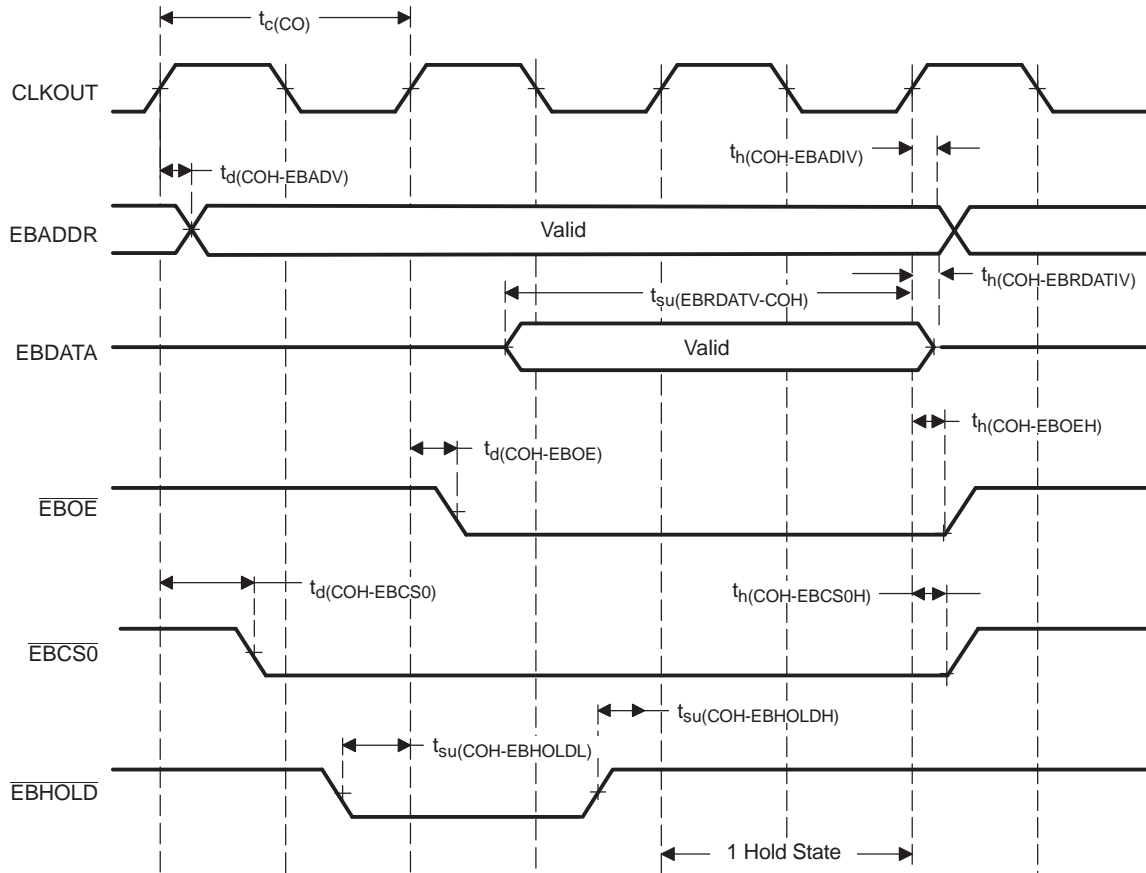

Figure 6-16. Expansion Memory Signal Timing - Reads

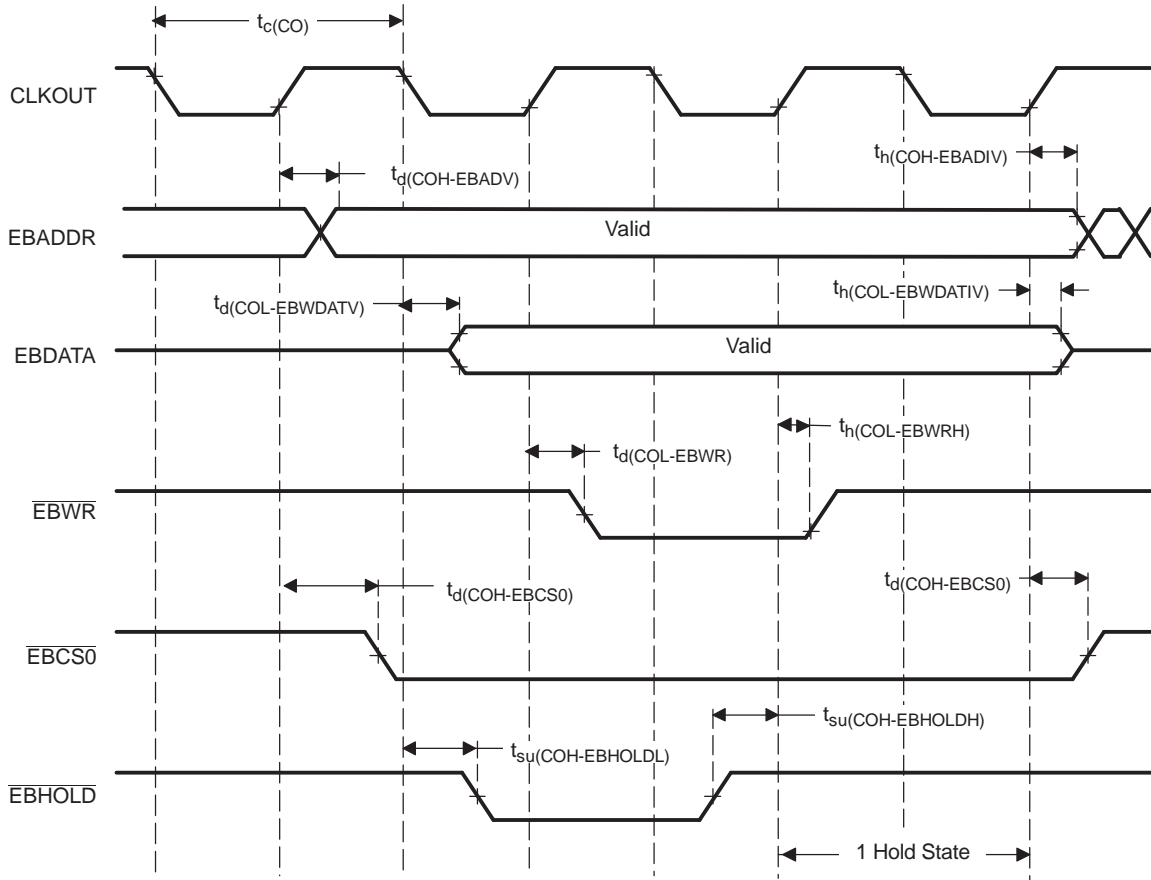

Figure 6-17. Expansion Memory Signal Timing - Writes

6.19 Multi-Buffered A-to-D Converter (MibADC)

The multi-buffered A-to-D converter (MibADC) has a separate power bus for its analog circuitry that enhances the A-to-D performance by preventing digital switching noise on the logic circuitry, which could be present on V_{SS} and V_{CC}, from coupling into the A-to-D analog stage. All A-to-D specifications are given with respect to AD_{REFLO} unless otherwise noted.

Resolution	10 bits (1024 values)
Monotonic	Assured
Output conversion code	00h to 3FFh [00 for V _{AI} ≤ AD _{REFLO} ; 3FF for V _{AI} ≥ AD _{REFHI}]

Table 6-19. MibADC Recommended Operating Conditions⁽¹⁾

		MIN	MAX	UNIT
AD _{REFHI}	A-to-D high-voltage reference source	V _{SSAD}	V _{CCAD}	V
AD _{REFLO}	A-to-D low-voltage reference source	V _{SSAD}	V _{CCAD}	V
V _{AI}	Analog input voltage	V _{SSAD} - 0.3	V _{CCAD} + 0.3	V
I _{AIC}	Analog input clamp current ⁽²⁾ (V _{AI} < V _{SSAD} - 0.3 or V _{AI} > V _{CCAD} + 0.3)	-2	2	mA

(1) For V_{CCAD} and V_{SSAD} recommended operating conditions, see the "Device Recommended Operating Conditions" table.
 (2) Input currents into any ADC input channel outside the specified limits could affect conversion results of other channels.

Table 6-20. Operating Characteristics over Full Ranges of Recommended Operating Conditions^{(1)(2)(3) (4)}

PARAMETER	DESCRIPTION/CONDITIONS	MIN	TYP	MAX	UNIT	
R _I	Analog input resistance	See Figure 6-18.		250	500	Ω
C _I	Analog input capacitance	See Figure 6-18.		10		pF
		Conversion		30		pF
I _{AIL}	Analog input leakage current	See Figure 6-18.		-1	1	μA
I _{ADREFHI}	AD _{REFHI} input current	AD _{REFHI} = 3.6 V, AD _{REFLO} = V _{SSAD}		5		mA
CR	Conversion range over which specified accuracy is maintained	AD _{REFHI} - AD _{REFLO}		3	3.6	V
E _{DNL}	Differential nonlinearity error	Difference between the actual step width and the ideal value. See Figure 6-19.		±1.5		LSB
E _{INL}	Integral nonlinearity error	Maximum deviation from the best straight line through the MibADC. MibADC transfer characteristics, excluding the quantization error. See Figure 6-20.		±2		LSB
E _{TOT}	Total error/Absolute accuracy	Maximum value of the difference between an analog value and the ideal midstep value. See Figure 6-21.		±2.5		LSB

- (1) Not production tested.
- (2) INL and DNL values are valid for a max ADCCLK frequency of 15 MHz. For frequencies greater than 15 MHz missing codes are expected at higher temperature.
- (3) V_{CCAD} = AD_{REFHI}
- (4) 1 LSB = (AD_{REFHI} - AD_{REFLO})/2¹⁰ for the MibADC

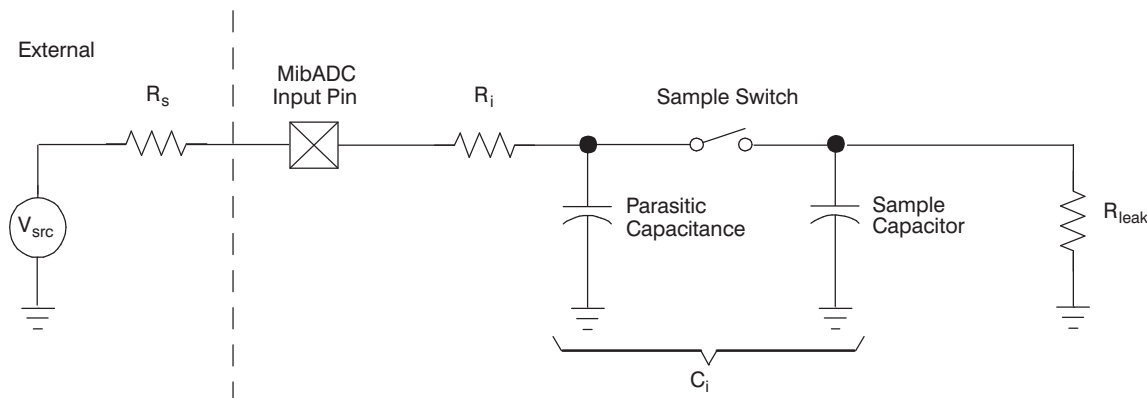

Figure 6-18. MibADC Input Equivalent Circuit

Table 6-21. Multi-Buffer ADC Timing Requirements⁽¹⁾

		MIN	NOM	MAX	UNIT
t _{c(ADCLK)}	Cycle time, MibADC clock	0.067			μs
t _{d(SH)}	Delay time, sample and hold time	1			μs
t _{d(c)}	Delay time, conversion time	0.55			μs
t _{d(SHC)} ⁽²⁾	Delay time, total sample/hold and conversion time	1.55			μs

- (1) Not production tested.
- (2) This is the minimum sample/hold and conversion time that can be achieved. These parameters are dependent on many factors; for more details, see the *TMS470R1x Multi-Buffered Analog-to-Digital Converter (MibADC) Reference Guide* (SPNU206).

The differential nonlinearity error shown in Figure 6-19 (sometimes referred to as differential linearity) is the difference between an actual step width and the ideal value of 1 LSB.

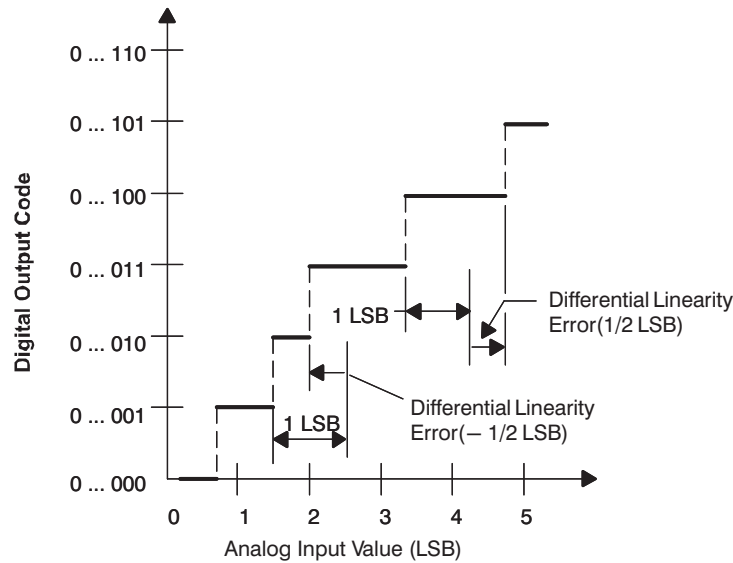

A. $1 \text{ LSB} = (AD_{REFHI} - AD_{REFLO}) / 2^{10}$

Figure 6-19. Differential Nonlinearity (DNL)

The integral nonlinearity error shown in Figure 6-20 (sometimes referred to as linearity error) is the deviation of the values on the actual transfer function from a straight line.

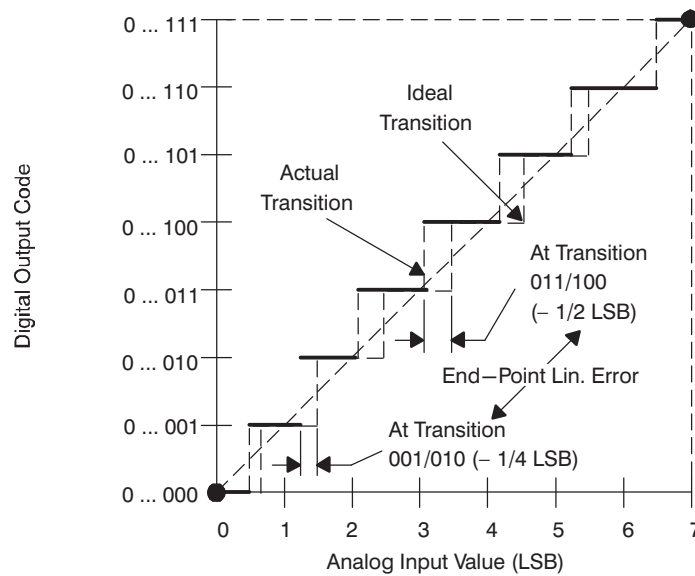

A. $1 \text{ LSB} = (AD_{REFHI} - AD_{REFLO}) / 2^{10}$

Figure 6-20. Integral Nonlinearity (INL) Error

The absolute accuracy or total error of an MibADC as shown in Figure 6-21 is the maximum value of the difference between an analog value and the ideal midstep value.

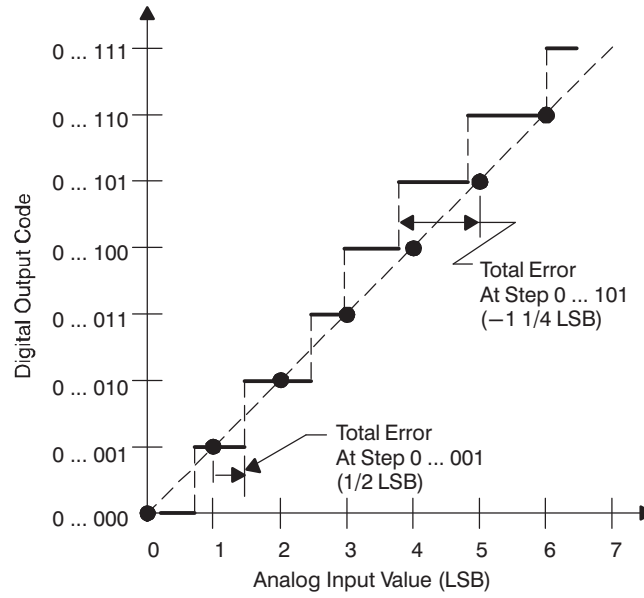

A. $1 \text{ LSB} = (AD_{\text{REFHI}} - AD_{\text{REFLO}}) / 2^{10}$

Figure 6-21. Absolute Accuracy (Total) Error

7 Parameter Measurement Information

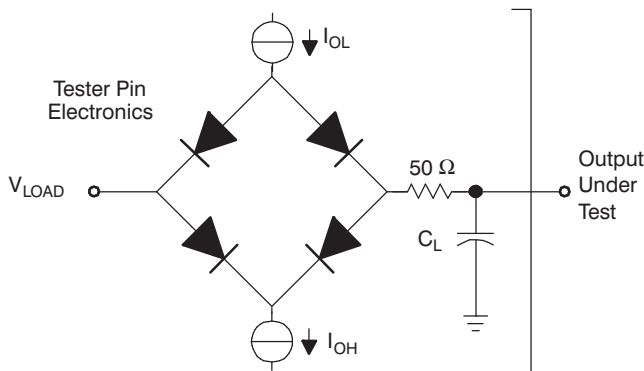

Where: I_{OL} = I_{OL} MAX for the respective pin^(A)
 I_{OH} = I_{OH} MIN for the respective pin^(A)
 V_{LOAD} = 1.5 V
 C_L = 150-pF typical load-circuit capacitance^(B)

- A. For these values, see the [Section 6.4](#).
- B. All timing parameters measured using an external load capacitance of 150 pF unless otherwise noted.

Figure 7-1. Test Load Circuit

7.1 External Reference Resonator/Crystal Oscillator Clock Option

The oscillator is enabled by connecting the appropriate fundamental 4–10 MHz resonator/crystal and load capacitors across the external OSCIN and OSCOUT pins as shown in [Figure 7-2 \(a\)](#). The oscillator is a single-stage inverter held in bias by an integrated bias resistor. This resistor is disabled during leakage test measurement and HALT mode. **TI strongly encourages each customer to submit samples of the device to the resonator/crystal vendors for validation.** The vendors are equipped to determine what load capacitors will best tune their resonator/crystal to the microcontroller device for optimum start-up and operation over temperature/voltage extremes. **Please note that external crystal mode is specified to function only within the temperature ranges of –40°C to 150°C. Above this recommended temperature range it is strongly recommended to use an external clock signal as shown in [Figure 7-2 \(b\)](#).**

An external oscillator source can be used by connecting a 1.8-V clock signal to the OSCIN pin and leaving the OSCOUT pin unconnected (open) as shown in [Figure 7-2b](#).

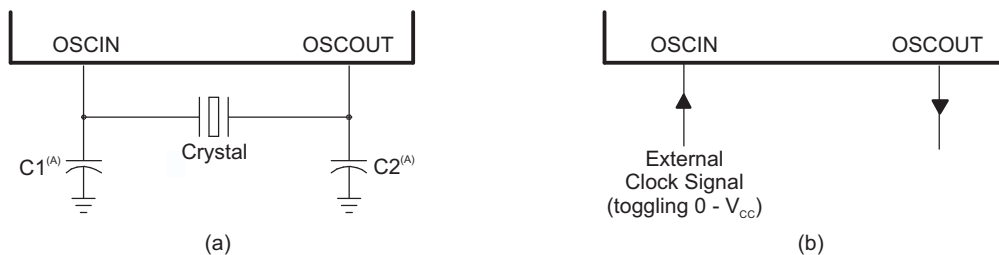

- A. The values of C1 and C2 should be provided by the resonator/crystal vendor.

Figure 7-2. Crystal/Clock Connection

8 Detailed Description

8.1 Overview

8.1.1 MibADC

The multi-buffered analog-to-digital converter (MibADC) accepts an analog signal and converts the signal to a 10-bit digital value.

The B1M MibADC module can function in two modes: compatibility mode, where its programmer's model is compatible with the SM470R1x ADC module and its digital results are stored in digital result registers; or in buffered mode, where the digital result registers are replaced with three FIFO buffers, one for each conversion group [event, group1 (G1), and group2 (G2)]. In buffered mode, the MibADC buffers can be serviced by interrupts or by the DMA.

8.1.1.1 MibADC Event Trigger Enhancements

The MibADC includes two major enhancements over the event-triggering capability of the SM470R1x ADC.

- Both group 1 and the event group can be configured for event-triggered operation, providing up to two event-triggered groups.
- The trigger source and polarity can be selected individually for both group1 and the event group from the options identified in [Table 8-1](#).

Table 8-1. MibADC Event Hookup Configuration

EVENT NO.	SOURCE SELECT BITS FOR G1 OR EVENT (G1SRC[1:0] OR EVSRC[1:0])	SIGNAL PIN NAME
EVENT1	00	ADEVT
EVENT2	01	HET18
EVENT3	10	Reserved
EVENT4	11	Reserved

For group1, these event-triggered selections are configured via the group 1 source select bits (G1SRC[1:0]) in the AD event source register (ADEVTSRC[5:4]). For the event group, these event-triggered selections are configured via the event group source select bits (EVSRC[1:0]) in the AD event source register (ADEVTSRC[1:0]).

For more detailed functional information on the MibADC, see the *TMS470R1x Multi-Buffered Analog-to-Digital Converter (MibADC) Reference Guide* ([SPNU206](#)).

8.1.2 JTAG Interface

There are two main test access ports (TAPs) on the device:

- SM470R1x CPU TAP
- Device TAP for factory test

Some of the JTAG pins are shared among these two TAPs. The hookup is illustrated in [Figure 8-1](#).

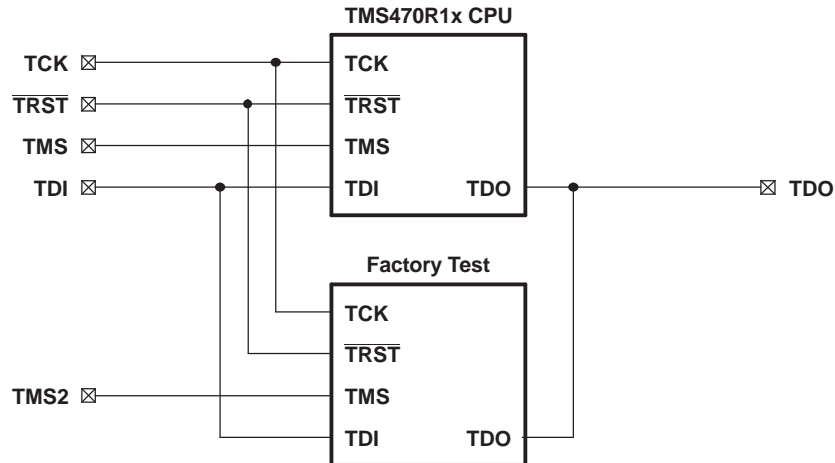

Figure 8-1. JTAG Interface

8.1.3 High-End Timer (HET) Timings

8.1.3.1 Minimum PWM Output Pulse Width

This is equal to one high resolution clock period (HRP). The HRP is defined by the 6-bit high resolution prescale factor (hr), which is user defined, giving prescale factors of 1 to 64, with a linear increment of codes.

Therefore, the minimum PWM output pulse width = $HRP(\min) = hr(\min)/SYSCLK = 1/SYSCLK$

For example, for a SYSCLK of 30 MHz, the minimum PWM output pulse width = $1/30 = 33.33 \text{ ns}$

8.1.3.2 Minimum Input Pulses that can be Captured

The input pulse width must be greater or equal to the low resolution clock period (LRP), that is, the HET loop (the HET program must fit within the LRP). The LRP is defined by the 3-bit loop-resolution prescale factor (lr), which is user defined, with a power of 2 increment of codes. That is, the value of lr can be 1, 2, 4, 8, 16, or 32.

Therefore, the minimum input pulse width = $LRP(\min) = lr(\min)/SYSCLK = 1 \times 1/SYSCLK$

For example, with a SYSCLK of 30 MHz, the minimum input pulse width = $1 \times 1/30 = 33.33 \text{ ns}$

NOTE

Once the input pulse width is greater than LRP, the resolution of the measurement is still HRP. (That is, the captured value gives the number of HRP clocks inside the pulse.)

Abbreviations:

hr = HET high resolution divide rate = 1, 2, 3,...63, 64

lr = HET low resolution divide rate = 1, 2, 4, 8, 16, 32

High resolution clock period = $HRP = hr/SYSCLK$

Loop resolution clock period = $LRP = lr \times HRP$

8.1.4 Interrupt Priority (IEM to CIM)

Interrupt requests originating from the B1M peripheral modules (that is, SPI1 or SPI2; SCI1 or SCI2; RTI; and so forth) are assigned to channels within the 48-channel interrupt expansion module (IEM) where, via programmable register mapping, these channels are then mapped to the 32-channel central interrupt manager (CIM) portion of the SYS module.

Programming multiple interrupt sources in the IEM to the same CIM channel effectively shares the CIM channel between sources.

The CIM request channels are maskable so that individual channels can be selectively disabled. All interrupt requests can be programmed in the CIM to be of either type:

- Fast interrupt request (FIQ)
- Normal interrupt request (IRQ)

The CIM prioritizes interrupts. The precedence of request channels decrease with ascending channel order in the CIM (0 [highest] and 31 [lowest] priority). For IEM-to-CIM default mapping, channel priorities, and their associated modules, see [Table 8-2](#).

Table 8-2. Interrupt Priority (IEM and CIM)

MODULES	INTERRUPT SOURCES	DEFAULT CIM INTERRUPT LEVEL/CHANNEL	IEM CHANNEL
SPI1	SPI1 end-transfer/overrun	0	0
RTI	COMP2 interrupt	1	1
RTI	COMP1 interrupt	2	2
RTI	TAP interrupt	3	3
SPI2	SPI2 end-transfer/overrun	4	4
GIO	GIO interrupt A	5	5
Reserved		6	6
HET	HET interrupt 1	7	7
I2C1	I2C1 interrupt	8	8
SCI1/SCI2	SCI1 or SCI2 error interrupt	9	9
SCI1	SCI1 receive interrupt	10	10
Reserved		11	11
I2C2	I2C2 interrupt	12	12
HECC1	HECC1 interrupt A	13	13
SCC	SCC interrupt A	14	14
Reserved		15	15
MibADC	MibADC end event conversion	16	16
SCI2	SCI2 receive interrupt	17	17
DMA	DMA interrupt 0	18	18
I2C3	I2C3 interrupt	19	19
SCI1	SCI1 transmit interrupt	20	20
System	SW interrupt (SSI)	21	21
Reserved		22	22
HET	HET interrupt 2	23	23
HECC1	HECC1 interrupt B	24	24
SCC	SCC interrupt B	25	25
SCI2	SCI2 transmit interrupt	26	26
MibADC	MibADC end Group 1 conversion	27	27
DMA	DMA Interrupt 1	28	28
GIO	GIO interrupt B	29	29
MibADC	MibADC end Group 2 conversion	30	30

Table 8-2. Interrupt Priority (IEM and CIM) (continued)

MODULES	INTERRUPT SOURCES	DEFAULT CIM INTERRUPT LEVEL/CHANNEL	IEM CHANNEL
SCI3	SCI3 error interrupt	31	31
Reserved		31	32–37
HECC2	HECC2 interrupt A	31	38
HECC2	HECC2 interrupt B	31	39
SCI3	SCI3 receive interrupt	31	40
SCI3	SCI3 transmit interrupt	31	41
I2C4	I2C4 interrupt	31	42
I2C5	I2C5 interrupt	31	43
Reserved		31	44–47

For more detailed functional information on the IEM, see the *TMS470R1x Interrupt Expansion Module (IEM) Reference Guide* ([SPNU211](#)). For more detailed functional information on the CIM, see the *TMS470R1x System Module Reference Guide* ([SPNU189](#)).

8.1.5 Expansion Bus Module (EBM)

The expansion bus module (EBM) is a standalone module used to bond out both general-purpose input/output pins and expansion bus interface pins. This module supports the multiplexing of the GIO and the expansion bus interface functions. The module also supports 8- and 16- bit expansion bus memory interface mappings as well as mapping of the following expansion bus signals:

- 27-bit address bus (EBADDR[26:0] for x8, 19-bit address bus (EBADDR[18:0] for x16)
- 8- or 16-bit data bus (EBDATA[7:0] or EBDATA[15:0])
- 2 write strobes (EBWR[1:0])
- 2 memory chip selects (EBCS[6:5])
- 1 output enable (EBOE)
- 1 external hold signal for interfacing to slow memories (EBHOLD)
- 1 DMA request line (EBDMAREQ[0])

Table 8-3 shows the multiplexing of I/O signals with the expansion bus interface signals. The mapping of these pins varies depending on the memory mode.

Table 8-3. Expansion Bus MUX Mapping⁽¹⁾

GIO	EXPANSION BUS MODULE PINS	
	x8 ⁽²⁾	x16 ⁽²⁾
GIOB[0]	EBDMAREQ[0]	EBDMAREQ[0]
GIOC[0]	$\overline{\text{EBOE}}$	$\overline{\text{EBOE}}$
GIOC[2:1]	$\overline{\text{EBWR}}[1:0]$	$\overline{\text{EBWR}}[1:0]$
GIOC[4:3]	$\overline{\text{EBCS}}[6:5]$	$\overline{\text{EBCS}}[6:5]$
GIOD[5:0]	EBADDR[5:0]	EBADDR[5:0]
GIOE[7:0]	EBDATA[7:0]	EBDATA[7:0]
GIOF[7:0]	EBADDR[13:6]	EBDATA[15:8]
GIOG[7:0]	EBADDR[21:14]	EBADDR[13:6]
GIOH[5]	$\overline{\text{EBHOLD}}$	$\overline{\text{EBHOLD}}$
I2C5SDA	EBADDR[26]	EBADDR[18]
I2C5SCL	EBADDR[25]	EBADDR[17]
I2C4SCL	EBADDR[24]	EBADDR[16]
I2C4SDA	EBADDR[23]	EBADDR[15]
GIOH[0]	EBADDR[22]	EBADDR[14]

(1) For more detailed information, see the *TMS470R1x Expansion Bus Module (EBM) Reference Guide* ([SPNU222](#)) and the *TMS470R1x General Purpose Input/Output Reference Guide* ([SPNU192](#)).

(2) X8 refers to size of memory in 8-bits; X16 refers to size of memory in 16-bits.

Table 8-4 lists the names of the expansion bus interface signals and their functions.

Table 8-4. Expansion Bus Pins

PIN	DESCRIPTION
EBDMAREQ	Expansion bus DMA request
$\overline{\text{EBOE}}$	Expansion bus pin enable
$\overline{\text{EBWR}}$	Expansion bus write strobe EBWR[1] controls EBDATA[15:8] and EBWR[0] controls EBDATA[7:0]
$\overline{\text{EBCS}}$	Expansion bus chip select
EBADDR	Expansion bus address pins
EBDATA	Expansion bus data pins
$\overline{\text{EBHOLD}}$	Expansion bus hold: An external device may assert this signal to add wait states to an expansion bus transaction.

8.2 Memory

Figure 8-2 shows the memory map of the B1M device.

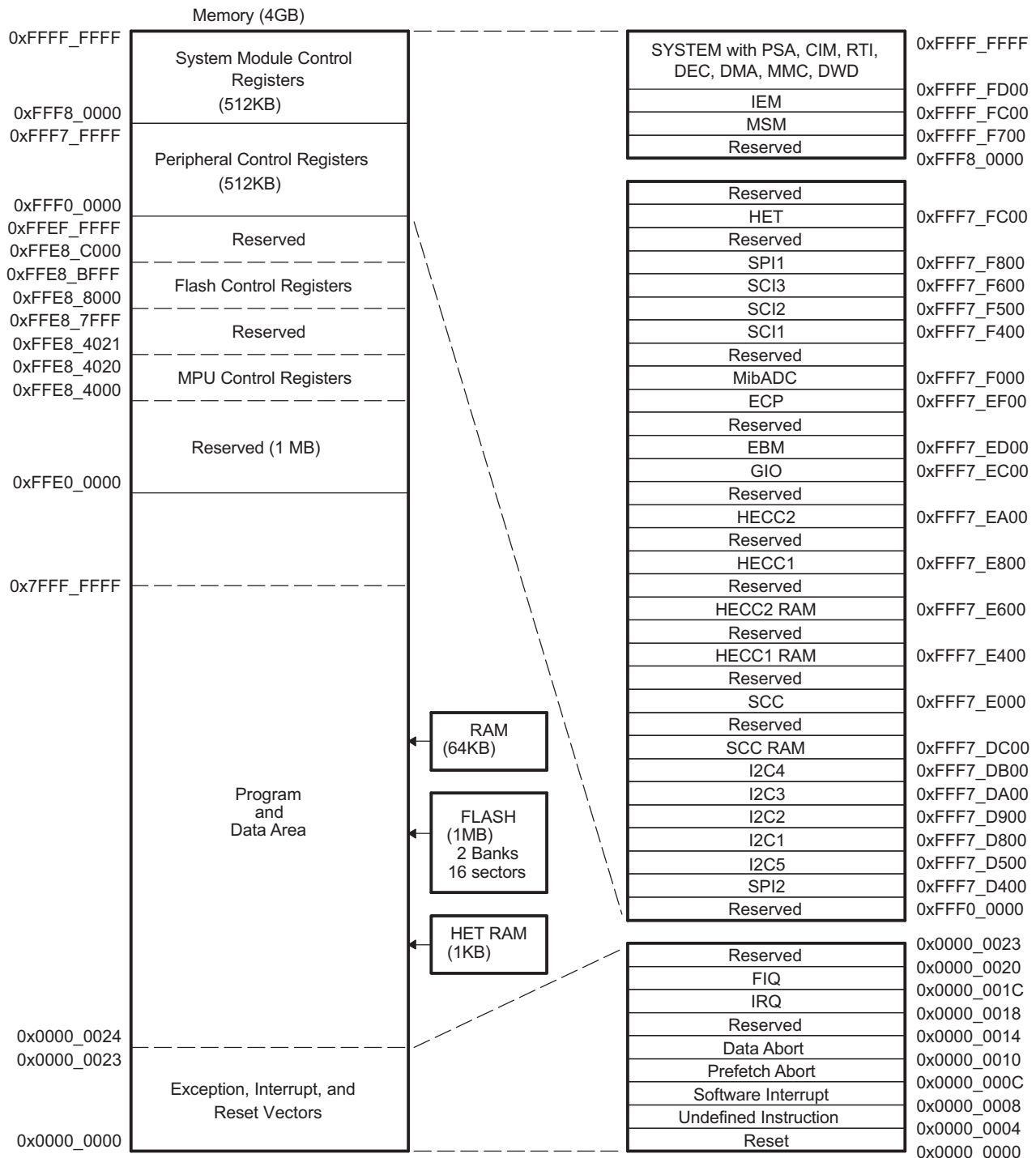

- A. Memory addresses are configurable by the system (SYS) module within the range of 0x0000_0000 to 0xFFE0_0000.
- B. The CPU registers are not part of the memory map.

Figure 8-2. SM470R1B1M Memory Map

8.2.1 Memory Selects

Memory selects allow the user to address memory arrays (that is, flash, RAM, and HET RAM) at user-defined addresses. Each memory select has its own set (low and high) of memory base address registers (MFBAHRx and MFBALRx) that, together, define the array's starting (base) address, block size, and protection.

The base address of each memory select is configurable to any memory address boundary that is a multiple of the decoded block size. For more information on how to control and configure these memory select registers, see the bus structure and memory sections of the *TMS470R1x System Module Reference Guide* ([SPNU189](#)).

For the memory selection assignments and the memory selected, see [Table 8-5](#).

Table 8-5. SM470R1B1M Memory Selection Assignment

MEMORY SELECT	MEMORY SELECTED (ALL INTERNAL)	MEMORY SIZE ⁽¹⁾	MPU	MSM	MEMORY BASE ADDRESS REGISTER	STATIC MEM CTL REGISTER
0 (fine)	FLASH/ROM	1 M	NO	YES	MFBAHR0 and MFBALR0	
1 (fine)	FLASH/ROM		NO	YES	MFBAHR1 and MFBALR1	
2 (fine)	RAM	64 K ⁽²⁾	YES	YES	MFBAHR2 and MFBALR2	
3 (fine)	RAM		YES	YES	MFBAHR3 and MFBALR3	
4 (fine)	HET RAM	1 K	NO	NO	MFBAHR4 and MFBALR4	SMCR1
5 (coarse)	$\overline{CS[5]}$ /GIOC[3]	512K x 8 (512KB) 256K x 16 (512KB)	NO	NO	MCBAHR2 and MCBALR2	SMCR5
6 (coarse)	$\overline{CS[6]}$ /GIOC[4]	512K x 8 (512KB) 256K x 16 (512KB)	NO	NO	MCBAHR3 and MCBALR3	SMCR6

(1) x8 refers to size of memory in 8-bits; x16 refers to size of memory in 16-bits.

(2) The starting addresses for both RAM memory-select signals cannot be offset from each other by a multiple of the user-defined block size in the memory-base address register.

8.2.1.1 JTAG Security Module

The B1M device includes a JTAG security module to provide maximum security to the memory contents. The visible unlock code can be in the OTP sector or in the first bank of the user-programmable memory. For the B1M, the visible unlock code is in the OTP sector at address 0x0000_01F8.

8.2.1.2 Memory Security Module

The B1M device also includes a memory security module (MSM) to provide additional security and flexibility to the memory contents' protection. The password for unlocking the MSM is located in the four words just before the flash protection keys.

8.2.1.3 RAM

The B1M device contains 64KB of internal static RAM configurable by the SYS module to be addressed within the range of 0x0000_0000 to 0xFFE0_0000. This B1M RAM is implemented in one 64KB array selected by two memory-select signals. This B1M configuration imposes an additional constraint on the memory map for RAM; the starting addresses for both RAM memory selects cannot be offset from each other by the multiples of the size of the physical RAM (that is, 64K bytes for the B1M device). The B1M RAM is addressed through memory selects 2 and 3.

The RAM can be protected by the memory protection unit (MPU) portion of the SYS module, allowing the user finer blocks of memory protection than is allowed by the memory selects. The MPU is ideal for protecting an operating system while allowing access to the current task. For more detailed information on the MPU portion of the SYS module and memory protection, see the memory section of the *TMS470R1x System Module Reference Guide* ([SPNU189](#)).

8.2.1.4 F05 Flash

The F05 flash memory is a nonvolatile electrically erasable and programmable memory implemented with a 32-bit-wide data bus interface. The F05 flash has an external state machine for programming and erase functions. See the *Flash read* and *Flash program and erase* sections.

8.2.1.4.1 Flash Protection Keys

The B1M device provides flash protection keys. These four 32-bit protection keys prevent program/erase/compaction operations from occurring until after the four protection keys have been matched by the CPU loading the correct user keys into the FMPKEY control register. The protection keys on the B1M are located in the last 4 words of the first 64K sector.

8.2.1.4.2 Flash Read

The B1M flash memory is configurable by the SYS module to be addressed within the range of 0x0000_0000 to 0xFFE0_0000. The flash is addressed through memory selects 0 and 1.

NOTE

The flash external pump voltage (V_{CCP}) is required for all operations (program, erase, and read).

8.2.1.4.3 Flash Pipeline Mode

When in pipeline mode, the flash operates with a system clock frequency of up to 60 MHz (versus a system clock frequency of 30 MHz in normal mode). Flash in pipeline mode is capable of accessing 64-bit words and provides two 32-bit pipelined words to the CPU. Also, in pipeline mode the flash can be read with no wait states when memory addresses are contiguous (after the initial 1- or 2-wait-state reads).

NOTE

After a system reset, pipeline mode is disabled (ENPIPE bit [FMREGOPT.0] is a 0). In other words, the B1M device powers up and comes out of reset in non-pipeline mode. Furthermore, setting the flash configuration mode bit (GBLCTRL.4) will override pipeline mode.

8.2.1.4.4 Flash Program and Erase

The B1M device flash contains two 512KB memory arrays (or banks), for a total of 1MB of flash, and consists of sixteen sectors. These sixteen sectors are sized as follows:

Table 8-6. Sectors

SECTOR NO.	SEGMENT	LOW ADDRESS	HIGH ADDRESS	MEMORY ARRAYS (OR BANKS)
OTP	2KB	0x0000_0000	0x0000_007FF	BANK0 (512KB)
0	64KB	0x0000_0000	0x0000_FFFF	
1	64KB	0x0001_0000	0x0001_FFFF	
2	64KB	0x0002_0000	0x0002_FFFF	
3	64KB	0x0003_0000	0x0003_FFFF	
4	64KB	0x0004_0000	0x0004_FFFF	
5	64KB	0x0005_0000	0x0005_FFFF	
6	64KB	0x0006_0000	0x0006_FFFF	
7	64KB	0x0007_0000	0x0007_FFFF	BANK1 (512KB)
0	64KB	0x0008_0000	0x0008_FFFF	
1	64KB	0x0009_0000	0x0009_FFFF	
2	64KB	0x000A_0000	0x000A_FFFF	
3	64KB	0x000B_0000	0x000B_FFFF	
4	64KB	0x000C_0000	0x000C_FFFF	
5	64KB	0x000D_0000	0x000D_FFFF	
6	64KB	0x000E_0000	0x000E_FFFF	
7	64KB	0x000F_0000	0x000F_FFFF	

The minimum size for an erase operation is one sector. The maximum size for a program operation is one 16-bit word.

NOTE

The flash external pump voltage (V_{CCP}) is required for all operations (program, erase, and read).

Execution can occur from one bank while programming/erasing any or all sectors of another bank. However, execution cannot occur from any sector within a bank that is being programmed or erased.

NOTE

When the OTP sector is enabled, the rest of flash memory is disabled. The OTP memory can only be read or programmed from code executed out of RAM.

8.2.1.4.5 HET RAM

The B1M device contains HET RAM. The HET RAM has a 64-instruction capability. The HET RAM is configurable by the SYS module to be addressed within the range of 0x0000_0000 to 0xFFE0_0000. The HET RAM is addressed through memory select 4.

8.2.1.4.6 Peripheral Selects and Base Addresses

The B1M device uses 10 of the 16 peripheral selects to decode the base addresses of the peripherals. These peripheral selects are fixed and transparent to the user since they are part of the decoding scheme used by the SYS module.

Control registers for the peripherals, SYS module, and flash begin at the base addresses shown in [Table 8-7](#).

Table 8-7. B1M Peripherals, System Module, and Flash Base Addresses

CONNECTING MODULE	ADDRESS RANGE		PERIPHERAL SELECTS
	BASE ADDRESS	ENDING ADDRESS	
SYSTEM	0 x FFFF_FFCC	0 x FFFF_FFFF	N/A
RESERVED	0 x FFFF_FF70	0 x FFFF_FFCB	N/A
DWD	0xFFFF_FF60	0 x FFFF_FF6F	N/A
PSA	0 x FFFF_FF40	0 x FFFF_FF5F	N/A
CIM	0 x FFFF_FF20	0 x FFFF_FF3F	N/A
RTI	0 x FFFF_FF00	0 x FFFF_FF1F	N/A
DMA	0 x FFFF_FE80	0 x FFFF_FEFF	N/A
DEC	0 x FFFF_FE00	0 x FFFF_FE7F	N/A
RESERVED	0xFFFF_FD80	0xFFFF_FDFF	N/A
MMC	0 x FFFF_FD00	0 x FFFF_FD7F	N/A
IEM	0 x FFFF_FC00	0 x FFFF_FCFE	N/A
RESERVED	0 x FFFF_Fb00	0 x FFFF_FBFF	N/A
RESERVED	0 x FFFF_Fa00	0 x FFFF_FAFF	N/A
DMA CMD BUFFER	0 x FFFF_F800	0 x FFFF_F9FF	N/A
MSM	0xFFFF_F700	0xFFFF_F7FF	N/A
RESERVED	0xFFFF8_0000	0xFFFF_F6FF	N/A
RESERVED	0 x FFF7_FD00	0xFFFF_FFFF	PS[0]
HET	0xFFFF7_FC00	0xFFFF7_FCFE	
RESERVED	0xFFFF7_F900	0xFFFF7_FBFF	PS[1]
SPI1	0xFFFF7_F800	0xFFFF7_F8FF	
RESERVED	0xFFFF7_F700	0xFFFF7_F7FF	PS[2]
SCI3	0xFFFF7_F600	0xFFFF7_F6FF	
SCI2	0xFFFF7_F500	0xFFFF7_F5FF	
SCI1	0xFFFF7_F400	0xFFFF7_F4FF	
RESERVED	0xFFFF7_F100	0xFFFF7_F3FF	PS[3]
MibADC	0xFFFF7_F000	0xFFFF7_F0FF	
ECP	0xFFFF7_EF00	0xFFFF7_EFFF	PS[4]
RESERVED	0xFFFF7_EE00	0xFFFF7_EEFF	
EBM	0xFFFF7_ED00	0xFFFF7_EDFF	
GIO	0xFFFF7_EC00	0xFFFF7_ECFE	
HECC2	0xFFFF7_EB00	0xFFFF7_EBFF	PS[5]
	0xFFFF7_EA00	0xFFFF7_EAFF	
HECC1	0xFFFF7_E900	0xFFFF7_E9FF	
	0xFFFF7_E800	0xFFFF7_E8FF	
HECC2 RAM	0xFFFF7_E700	0xFFFF7_E7FF	PS[6]
	0xFFFF7_E600	0xFFFF7_E6FF	
HECC1 RAM	0xFFFF7_E500	0xFFFF7_E5FF	
	0xFFFF7_E400	0xFFFF7_E4FF	

Table 8-7. B1M Peripherals, System Module, and Flash Base Addresses (continued)

CONNECTING MODULE	ADDRESS RANGE		PERIPHERAL SELECTS
	BASE ADDRESS	ENDING ADDRESS	
RESERVED	0xFFF7_E100	0xFFF7_E3FF	PS[7]
SCC	0xFFF7_E000	0xFFF7_E0FF	
RESERVED	0xFFF7_DD00	0xFFF7_DFFF	PS[8]
SCC RAM	0xFFF7_DC00	0xFFF7_DCFE	
I2C4	0xFFF7_DB00	0xFFF7_DBFF	PS[9]
I2C3	0xFFF7_DA00	0xFFF7_DAFF	
I2C2	0xFFF7_D900	0xFFF7_D9FF	
I2C1	0xFFF7_D800	0xFFF7_D8FF	
RESERVED	0xFFF7_D600	0xFFF7_D7FF	PS[10]
I2C5	0xFFF7_D500	0xFFF7_D5FF	
SPI2	0xFFF7_D400	0xFFF7_D4FF	
RESERVED	0xFFF7_CC00	0xFFF7_D3FF	PS[11] – PS[12]
RESERVED	0xFFF7_C800	0xFFF7_CBFF	PS[13]
RESERVED	0xFFF7_C000	0xFFF7_C7FF	PS[14] – PS[15]
RESERVED	0xFFF0_0000	0xFFF7_BFFF	N/A
FLASH CONTROL REGISTERS	0xFFE8_8000	0xFFE8_BFFF	N/A
RESERVED	0xFFF8_4024	0xFFF8_7FFF	N/A
MPU CONTROL REGISTERS	0xFFE8_4000	0xFFE8_4023	N/A
RESERVED	0xFFF8_0000	0xFFF8_3FFF	N/A

8.2.1.4.7 Direct-Memory Access (DMA)

The direct-memory access (DMA) controller transfers data to and from any specified location in the B1M memory map (except for restricted memory locations like the system control registers area). The DMA manages up to 16 channels, and supports data transfer for both on-chip and off-chip memories and peripherals. The DMA controller is connected to both the CPU and peripheral buses, enabling these data transfers to occur in parallel with CPU activity and thus maximizing overall system performance.

Although the DMA controller has two possible configurations, for the B1M device, the DMA controller configuration is 32 control packets and 16 channels.

For the B1M DMA request hardwired configuration, see [Table 8-8](#).

Table 8-8. DMA Request Lines Connections⁽¹⁾

MODULES	DMA REQUEST INTERRUPT SOURCES		DMA CHANNEL
EBM	Expansion Bus DMA request	EBDMAREQ[0]	DMAREQ[0]
SPI1/I2C4	SPI1 end-recvie/I2C4 read	SPI1DMA0/I2C4DMA0	DMAREQ[1]
SPI1/I2C4	SPI1 end-transmit/I2C4 write	SPI1DMA1/I2C4DMA1	DMAREQ[2]
MibADC/I2C1	ADC EV/I2C1 read	MibADCMA0/I2C1DMA0	DMAREQ[3]
MibADC/SCI1/I2C5	ADC G1/SCI1 end-recvie/I2C5 read	MibADCMA1/SCI1DMA0/I2C5DMA0	DMAREQ[4]
MibADC/SCI1/I2C5	ADC G2/SCI1 end-transmit/I2C5 write	MibADCMA2/SCI1DMA1/I2C5DMA1	DMAREQ[5]
I2C1	I2C1 write	I2C1DMA1	DMAREQ[6]
SCI3/SPI2	SCI3 end-recvie/SPI2 end-recvie	SCI3DMA0/SPI2DMA0	DMAREQ[7]
SCI3/SPI2	SCI3 end-transmit/SPI2 end-transmit	SCI3DMA0/SPI2DMA1	DMAREQ[8]
I2C2	I2C2 read end-recvie	I2C2DMA0	DMAREQ[9]
I2C2	I2C2 write end-transmit	I2C2DMA1	DMAREQ[10]
I2C3	I2C3 read	I2C3DMA0	DMAREQ[11]
I2C3	I2C3 write	I2C3DMA1	DMAREQ[12]
Reserved			DMAREQ[13]
SCI2	SCI2 end-recvie	SCI2DMA0	DMAREQ[14]
SCI2	SCI2 end-transmit	SCI2DMA1	DMAREQ[15]

- (1) For DMA channels with more than one assigned request source, *only one* of the sources listed can be the DMA request generator in a given application. The device has software control to ensure that there are no conflicts between requesting modules.

Each channel has two control packets attached to it, allowing the DMA to continuously load RAM and generate periodic interrupts so that the data can be read by the CPU. The control packets allow for the interrupt enable, and the channels determine the priority level of the interrupt.

DMA transfers occur in one of two modes:

- Non-request mode (used when transferring from memory to memory)
- Request mode (used when transferring from memory to peripheral)

For more detailed functional information on the DMA controller, see the *TMS470R1x Direct Memory Access (DMA) Controller Reference Guide* ([SPNU194](#)).

9 Device and Documentation Support

9.1 Device Support

9.1.1 Device Identification Code Register

The device identification code register identifies the silicon version, the technology family (TF), a ROM or flash device, and an assigned device-specific part number (see [Table 9-1](#)). The B1M device identification code register value is 0xnA5F.

Figure 9-1. SM470 Device ID Bit Allocation Register [offset = 0xFFFF_FFF0h]

31	30	29	28	27	26	25	24	23	22	21	20	19	18	17	16
Reserved															
15	14	13	12	11	10	9	8	7	6	5	4	3	2	1	0
VERSION				TF	R/F	PART NUMBER						1	1	1	
R-K				R-K	R-K	R-K						R-1	R-1	R-1	

LEGEND:

For bits 3-15: R = Read only, -K = Value constant after $\overline{\text{RESET}}$.

For bits 0-2: R = Read only, -1 = Value after RESET.

Table 9-1. SM470 Device ID Bit Allocation Register Field Descriptions

BIT	FIELD	VALUE	DESCRIPTION
31-16	Reserved		Reads are undefined and writes have no effect.
15-12	VERSION		Silicon version (revision) bits These bits identify the silicon version of the device.
11	TF	0 1	Technology family bit This bit distinguishes the technology family core power supply: 3.3 V for F10/C10 devices 1.8 V for F05/C05 devices
10	R/F	0 1	ROM/flash bit This bit distinguishes between ROM and flash devices: Flash device ROM device
9-3	PART NUMBER		Device-specific part number bits These bits identify the assigned device-specific part number. The assigned device-specific part number for the B1M device is 1001011.
2-0	1		Mandatory High Bits 2, 1, and 0 are tied high by default.

9.1.2 Timing Parameter Symbolology

Timing parameter symbols have been created in accordance with JEDEC Standard 100. To shorten the symbols, some of the pin names and other related terminology have been abbreviated as follows:

CM	Compaction, CMPCT	RD	Read
CO	CLKOUT	RST	Reset, $\overline{\text{RST}}$
ER	Erase	RX	SCInRX
ICLK	Interface clock	S	Slave mode
M	Master mode	SCC	SCInCLK
OSC, OSC1	OSCIN	SIMO	SPIInSIMO
OSCO	OSCOOUT	SOMI	SPIInSOMI
P	Program, PROG	SPC	SPIInCLK

R	Ready	SYS	System clock
R0	Read margin 0, RDMRGN0	TX	SCInTX
R1	Read margin 1, RDMRGN1		

Lowercase subscripts and their meanings are:

a	access time	r	rise time
c	cycle time (period)	su	setup time
d	delay time	t	transition time
f	fall time	v	valid time
h	hold time	w	pulse duration (width)

The following additional letters are used with these meanings:

H	High	X	Unknown, changing, or don't care level
L	Low	Z	High impedance
V	Valid		

9.2 Development Support

TI offers an extensive line of development tools, including tools to evaluate the performance of the processors, generate code, develop algorithm implementations, and fully integrate and debug software and hardware modules. The tool's support documentation is electronically available within the Code Composer Studio™ Integrated Development Environment (IDE).

The following products support development of the SM470R1B1M-HT device applications:

Software Development Tools: Code Composer Studio™ Integrated Development Environment (IDE): including Editor C/C++/Assembly Code Generation, and Debug plus additional development tools Scalable, Real-Time Foundation Software (DSP/BIOS™), which provides the basic run-time target software needed to support any SM470R1B1M-HT device application.

Hardware Development Tools: Extended Development System (XDS™) Emulator

For a complete listing of development-support tools for the SM470R1B1M-HT platform, visit the Texas Instruments website at www.ti.com. For information on pricing and availability, contact the nearest TI field sales office or authorized distributor.

9.3 Device Nomenclature

To designate the stages in the product development cycle, TI assigns prefixes to the part numbers of all DSP devices and support tools. Each DSP commercial family member has one of three prefixes: TMX, TMP, or TMS (for example, **TMS470R1B1M**). Texas Instruments recommends two of three possible prefix designators for its support tools: TMDX and TMDS. These prefixes represent evolutionary stages of product development from engineering prototypes (TMX/TMDX) through fully qualified production devices/tools (TMS/TMDS).

Device development evolutionary flow:

TMX	Experimental device that is not necessarily representative of the final device's electrical specifications
TMP	Final silicon die that conforms to the device's electrical specifications but has not completed quality and reliability verification
SM	Fully qualified production device

Support tool development evolutionary flow:

TMDX Development-support product that has not yet completed Texas Instruments internal qualification testing.

TMDS Fully qualified development-support product

TMX and TMP devices and TMDX development-support tools are shipped against the following disclaimer:

"Developmental product is intended for internal evaluation purposes."

TMS devices and TMDS development-support tools have been characterized fully, and the quality and reliability of the device have been demonstrated fully. TI's standard warranty applies.

Predictions show that prototype devices (TMX or TMP) have a greater failure rate than the standard production devices. Texas Instruments recommends that these devices not be used in any production system because their expected end-use failure rate still is undefined. Only qualified production devices are to be used.

Figure 9-2 illustrates the numbering and symbol nomenclature for the SM470R1x family.

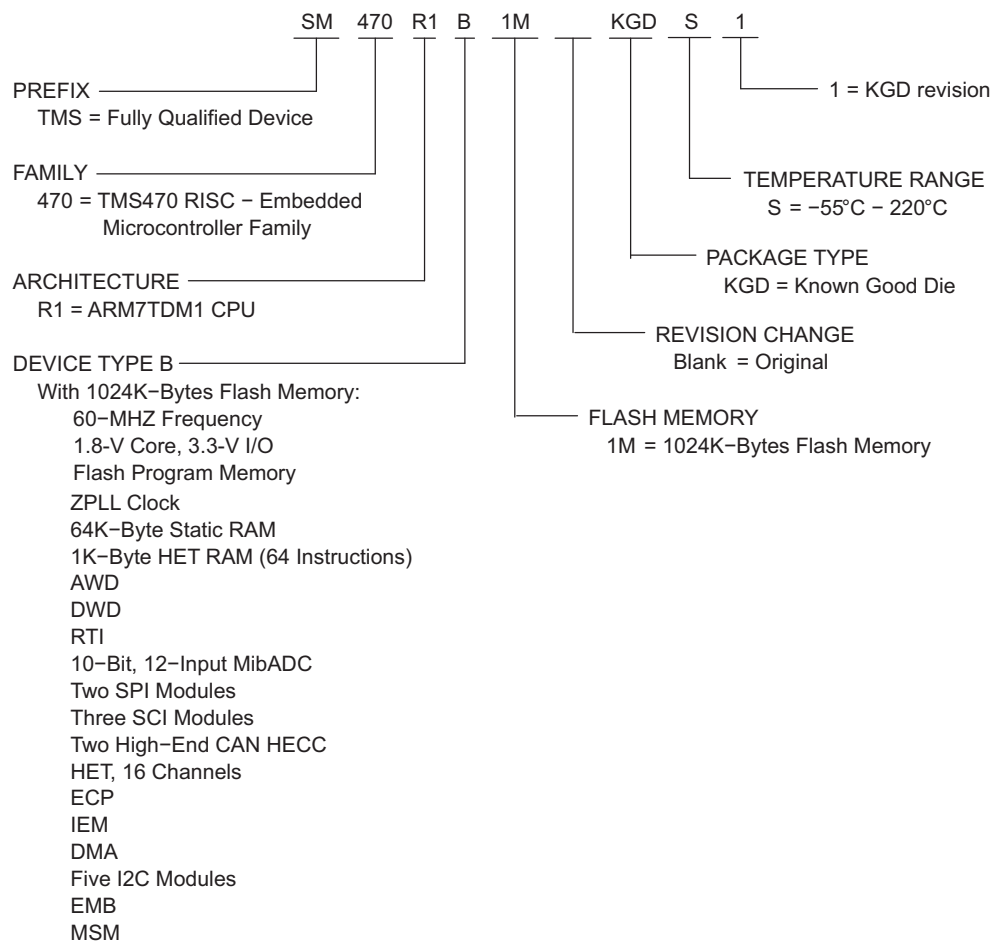

Figure 9-2. SM470R1x Family Nomenclature

9.4 Documentation Support

Extensive documentation supports all of the SM470 microcontroller family generation of devices. The types of documentation available include data sheets with design specifications; complete user's guides for all devices and development support tools; and hardware and software applications. Useful reference documentation includes:

- Bulletin
 - *TMS470 Microcontroller Family Product Bulletin* ([SPNB086](#))
- User's Guides
 - *TMS470R1x System Module Reference Guide* ([SPNU189](#))
 - *TMS470R1x General Purpose Input/Output (GPIO) Reference Guide* ([SPNU192](#))
 - *TMS470R1x Direct Memory Access (DMA) Controller Reference Guide* ([SPNU194](#))
 - *TMS470R1x Direct Memory Access (DMA) Controller Reference Guide* ([SPNU194](#))
 - *TMS470R1x Serial Peripheral Interface (SPI) Reference Guide* ([SPNU195](#))
 - *TMS470R1x Serial Communication Interface (SCI) Reference Guide* ([SPNU196](#))
 - *TMS470R1x Controller Area Network (CAN) Reference Guide* ([SPNU197](#))
 - *TMS470R1x High End Timer (HET) Reference Guide* ([SPNU199](#))
 - *TMS470R1x External Clock Prescale (ECP) Reference Guide* ([SPNU202](#))
 - *TMS470R1x MultiBuffered Analog to Digital (MibADC) Reference Guide* ([SPNU206](#))
 - *TMS470R1x Zero Pin Phase Locked Loop (ZPLL) Clock Module Reference Guide* ([SPNU212](#))
 - *TMS470R1x Digital Watchdog Timer Reference Guide* ([SPNU244](#))
 - *TMS470R1x Interrupt Expansion Module (IEM) Reference Guide* ([SPNU211](#))
 - *TMS470R1x Class II Serial Interface B (C2SIb) Reference Guide* ([SPNU214](#))
 - *TMS470R1x Class II Serial Interface A (C2SIa) Reference Guide* ([SPNU218](#))
 - *TMS470R1x Expansion Bus Module (EBM) Reference Guide* ([SPNU222](#))
 - *TMS470R1x Inter-Integrated Circuit (I2C) Reference Guide* ([SPNU223](#))
 - *TMS470R1x JTAG Security Module (JSM) Reference Guide* ([SPNU245](#))
 - *TMS470R1x Memory Security Module (MSM) Reference Guide* ([SPNU246](#))
 - *TMS470 Peripherals Overview Reference Guide* ([SPNU248](#))
- Errata Sheet
 - *TMS470R1B1M TMS470 Microcontrollers Silicon Errata* ([SPNZ139](#))

9.5 Community Resources

The following links connect to TI community resources. Linked contents are provided "AS IS" by the respective contributors. They do not constitute TI specifications and do not necessarily reflect TI's views; see TI's [Terms of Use](#).

[TI E2E™ Online Community](#) *TI's Engineer-to-Engineer (E2E) Community*. Created to foster collaboration among engineers. At e2e.ti.com, you can ask questions, share knowledge, explore ideas and help solve problems with fellow engineers.

[TI Embedded Processors Wiki](#) *Texas Instruments Embedded Processors Wiki*. Established to help developers get started with Embedded Processors from Texas Instruments and to foster innovation and growth of general knowledge about the hardware and software surrounding these devices.

9.6 Trademarks

E2E is a trademark of Texas Instruments.

ARM7TDMI is a trademark of Advanced RISC Machines Limited (ARM).

All other trademarks are the property of their respective owners.

9.7 Electrostatic Discharge Caution



This integrated circuit can be damaged by ESD. Texas Instruments recommends that all integrated circuits be handled with appropriate precautions. Failure to observe proper handling and installation procedures can cause damage.

ESD damage can range from subtle performance degradation to complete device failure. Precision integrated circuits may be more susceptible to damage because very small parametric changes could cause the device not to meet its published specifications.

9.8 Glossary

[SLYZ022](#) — *TI Glossary*.





This glossary lists and explains terms, acronyms, and definitions.

10 Mechanical Packaging and Orderable Information

10.1 Packaging Information

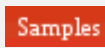
The following pages include mechanical packaging and orderable information. This information is the most current data available for the designated devices. This data is subject to change without notice and revision of this document. For browser-based versions of this data sheet, refer to the left-hand navigation.

PACKAGING INFORMATION

Orderable Device	Status (1)	Package Type	Package Drawing	Pins	Package Qty	Eco Plan (2)	Lead/Ball Finish (6)	MSL Peak Temp (3)	Op Temp (°C)	Device Marking (4/5)	Samples
SM470R1B1MHFQS	ACTIVE	CFP	HFQ	84	1	TBD	AU	N / A for Pkg Type	-55 to 220	SM470R1B1MHFQS	
SM470R1B1MHKPS	ACTIVE	CFP	HKP	84	10	TBD	Call TI	N / A for Pkg Type	-55 to 220	SM470R1B1MHKPS	
SM470R1B1MKGDS1	ACTIVE	XCEPT	KGD	0	36	TBD	Call TI	N / A for Pkg Type	-55 to 220		
SM470R1B1MPGES	ACTIVE	LQFP	PGE	144	60	Green (RoHS & no Sb/Br)	CU NIPDAU	Level-4-260C-72 HR	-55 to 150	R1B1MPGES SM470	

(1) The marketing status values are defined as follows:

ACTIVE: Product device recommended for new designs.

LIFEBUY: TI has announced that the device will be discontinued, and a lifetime-buy period is in effect.

NRND: Not recommended for new designs. Device is in production to support existing customers, but TI does not recommend using this part in a new design.

PREVIEW: Device has been announced but is not in production. Samples may or may not be available.

OBSELETE: TI has discontinued the production of the device.

(2) Eco Plan - The planned eco-friendly classification: Pb-Free (RoHS), Pb-Free (RoHS Exempt), or Green (RoHS & no Sb/Br) - please check <http://www.ti.com/productcontent> for the latest availability information and additional product content details.

TBD: The Pb-Free/Green conversion plan has not been defined.

Pb-Free (RoHS): TI's terms "Lead-Free" or "Pb-Free" mean semiconductor products that are compatible with the current RoHS requirements for all 6 substances, including the requirement that lead not exceed 0.1% by weight in homogeneous materials. Where designed to be soldered at high temperatures, TI Pb-Free products are suitable for use in specified lead-free processes.

Pb-Free (RoHS Exempt): This component has a RoHS exemption for either 1) lead-based flip-chip solder bumps used between the die and package, or 2) lead-based die adhesive used between the die and leadframe. The component is otherwise considered Pb-Free (RoHS compatible) as defined above.

Green (RoHS & no Sb/Br): TI defines "Green" to mean Pb-Free (RoHS compatible), and free of Bromine (Br) and Antimony (Sb) based flame retardants (Br or Sb do not exceed 0.1% by weight in homogeneous material)

(3) MSL, Peak Temp. - The Moisture Sensitivity Level rating according to the JEDEC industry standard classifications, and peak solder temperature.

(4) There may be additional marking, which relates to the logo, the lot trace code information, or the environmental category on the device.

(5) Multiple Device Markings will be inside parentheses. Only one Device Marking contained in parentheses and separated by a "~" will appear on a device. If a line is indented then it is a continuation of the previous line and the two combined represent the entire Device Marking for that device.

(6) Lead/Ball Finish - Orderable Devices may have multiple material finish options. Finish options are separated by a vertical ruled line. Lead/Ball Finish values may wrap to two lines if the finish value exceeds the maximum column width.

Important Information and Disclaimer: The information provided on this page represents TI's knowledge and belief as of the date that it is provided. TI bases its knowledge and belief on information provided by third parties, and makes no representation or warranty as to the accuracy of such information. Efforts are underway to better integrate information from third parties. TI has taken and continues to take reasonable steps to provide representative and accurate information but may not have conducted destructive testing or chemical analysis on incoming materials and chemicals. TI and TI suppliers consider certain information to be proprietary, and thus CAS numbers and other limited information may not be available for release.

In no event shall TI's liability arising out of such information exceed the total purchase price of the TI part(s) at issue in this document sold by TI to Customer on an annual basis.

HFQ (S-CQFP-F84)

CERAMIC QUAD FLATPACK WITH NCTB

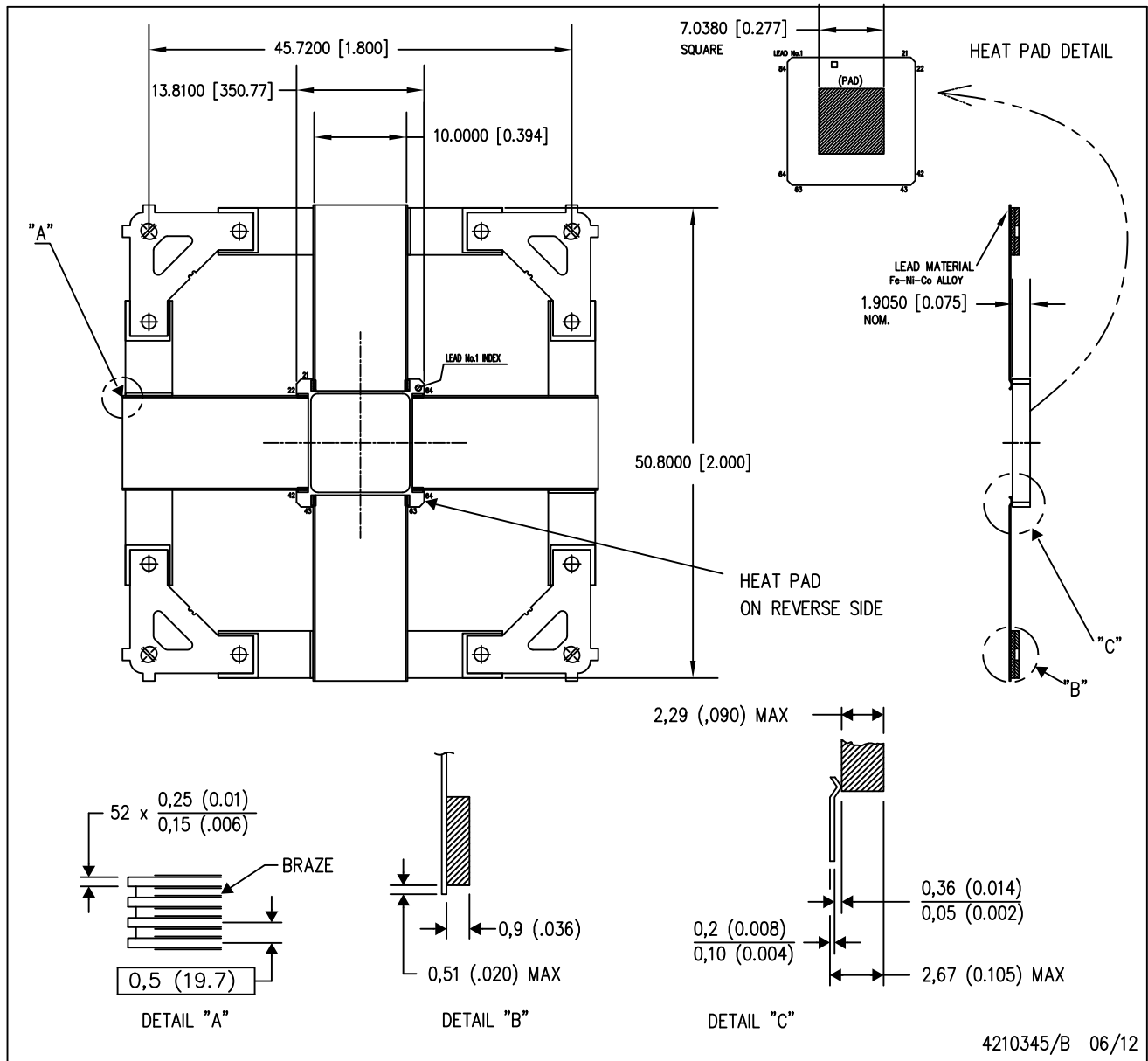

4210345/B 06/12

- NOTES:
- A. All linear dimensions are in millimeters (inches).
 - B. This drawing is subject to change without notice.
 - C. Ceramic quad flatpack with flat leads brazed to non-conductive tie bar carrier.
 - D. This package is hermetically sealed with a metal lid.
 - E. The leads are gold plated and can be solderdipped.
 - F. Leads not shown for clarity purposes.
 - G. Lid and heat sink are connected to GND leads.

MECHANICAL DATA

HKP (S-CQFP-G84)

CERAMIC QUAD FLATPACK – GULL WING

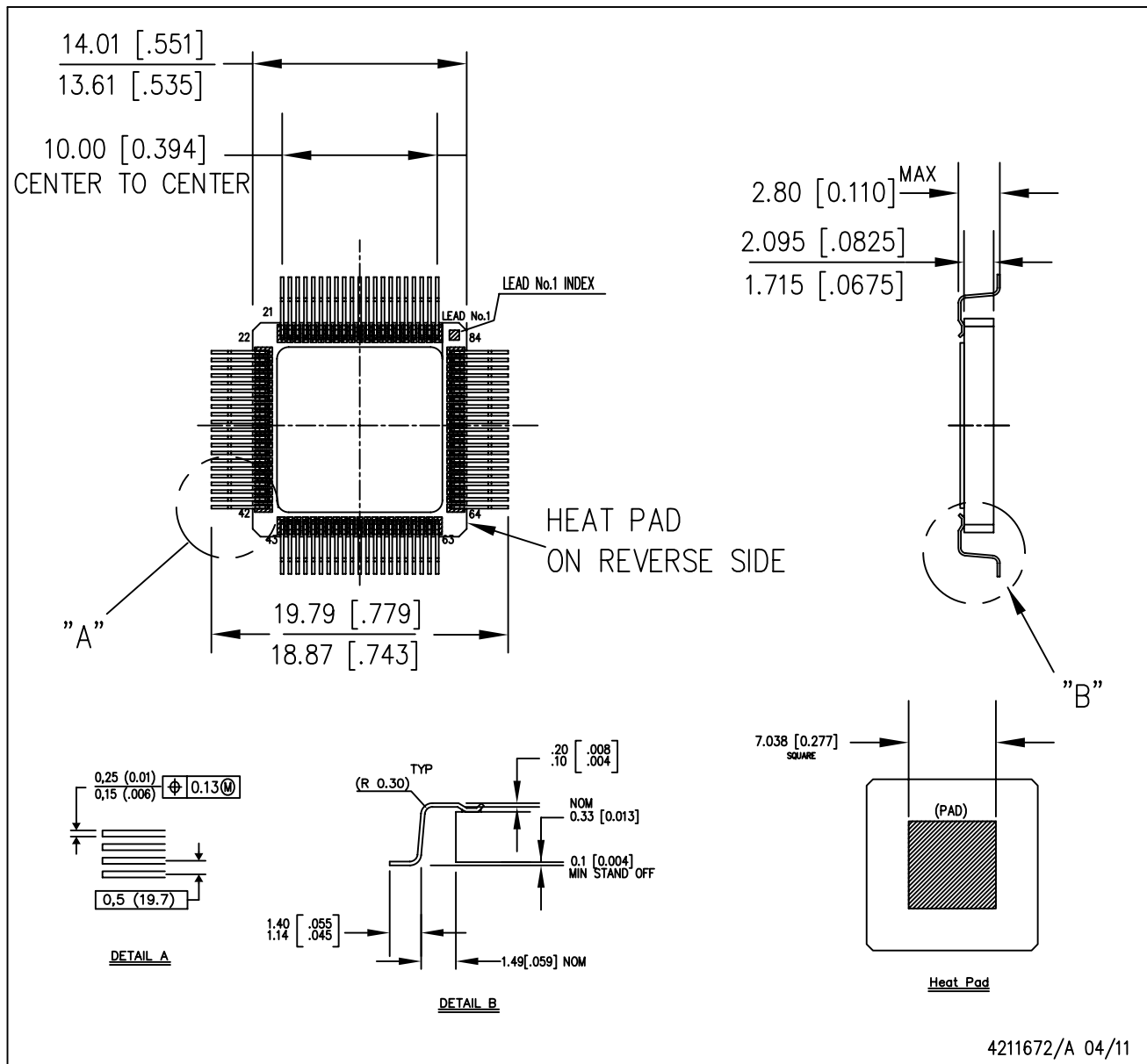

- NOTES:
- All linear dimensions are in millimeters (inches).
 - This drawing is subject to change without notice.
 - Ceramic quad flatpack with formed leads.
 - This package is hermetically sealed with a metal lid.
 - The leads are gold plated and can be solderdipped.
 - Lid and heat pad are electrically connected.

PGE (S-PQFP-G144)

PLASTIC QUAD FLATPACK

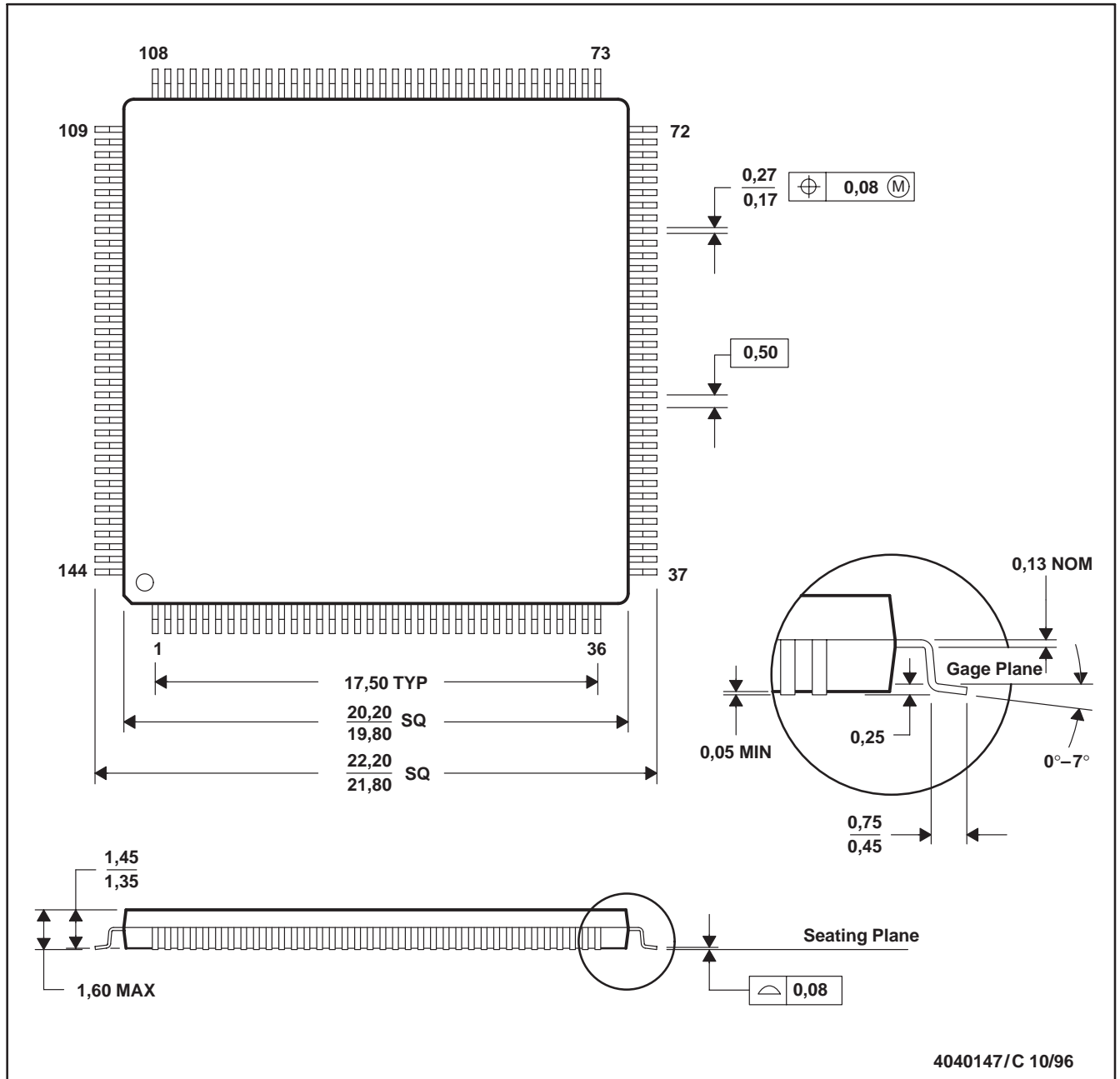

- NOTES: A. All linear dimensions are in millimeters.
 B. This drawing is subject to change without notice.
 C. Falls within JEDEC MS-026

IMPORTANT NOTICE

Texas Instruments Incorporated and its subsidiaries (TI) reserve the right to make corrections, enhancements, improvements and other changes to its semiconductor products and services per JESD46, latest issue, and to discontinue any product or service per JESD48, latest issue. Buyers should obtain the latest relevant information before placing orders and should verify that such information is current and complete. All semiconductor products (also referred to herein as "components") are sold subject to TI's terms and conditions of sale supplied at the time of order acknowledgment.

TI warrants performance of its components to the specifications applicable at the time of sale, in accordance with the warranty in TI's terms and conditions of sale of semiconductor products. Testing and other quality control techniques are used to the extent TI deems necessary to support this warranty. Except where mandated by applicable law, testing of all parameters of each component is not necessarily performed.

TI assumes no liability for applications assistance or the design of Buyers' products. Buyers are responsible for their products and applications using TI components. To minimize the risks associated with Buyers' products and applications, Buyers should provide adequate design and operating safeguards.

TI does not warrant or represent that any license, either express or implied, is granted under any patent right, copyright, mask work right, or other intellectual property right relating to any combination, machine, or process in which TI components or services are used. Information published by TI regarding third-party products or services does not constitute a license to use such products or services or a warranty or endorsement thereof. Use of such information may require a license from a third party under the patents or other intellectual property of the third party, or a license from TI under the patents or other intellectual property of TI.

Reproduction of significant portions of TI information in TI data books or data sheets is permissible only if reproduction is without alteration and is accompanied by all associated warranties, conditions, limitations, and notices. TI is not responsible or liable for such altered documentation. Information of third parties may be subject to additional restrictions.

Resale of TI components or services with statements different from or beyond the parameters stated by TI for that component or service voids all express and any implied warranties for the associated TI component or service and is an unfair and deceptive business practice. TI is not responsible or liable for any such statements.

Buyer acknowledges and agrees that it is solely responsible for compliance with all legal, regulatory and safety-related requirements concerning its products, and any use of TI components in its applications, notwithstanding any applications-related information or support that may be provided by TI. Buyer represents and agrees that it has all the necessary expertise to create and implement safeguards which anticipate dangerous consequences of failures, monitor failures and their consequences, lessen the likelihood of failures that might cause harm and take appropriate remedial actions. Buyer will fully indemnify TI and its representatives against any damages arising out of the use of any TI components in safety-critical applications.

In some cases, TI components may be promoted specifically to facilitate safety-related applications. With such components, TI's goal is to help enable customers to design and create their own end-product solutions that meet applicable functional safety standards and requirements. Nonetheless, such components are subject to these terms.

No TI components are authorized for use in FDA Class III (or similar life-critical medical equipment) unless authorized officers of the parties have executed a special agreement specifically governing such use.

Only those TI components which TI has specifically designated as military grade or "enhanced plastic" are designed and intended for use in military/aerospace applications or environments. Buyer acknowledges and agrees that any military or aerospace use of TI components which have **not** been so designated is solely at the Buyer's risk, and that Buyer is solely responsible for compliance with all legal and regulatory requirements in connection with such use.

TI has specifically designated certain components as meeting ISO/TS16949 requirements, mainly for automotive use. In any case of use of non-designated products, TI will not be responsible for any failure to meet ISO/TS16949.

Products

Audio	www.ti.com/audio
Amplifiers	amplifier.ti.com
Data Converters	dataconverter.ti.com
DLP® Products	www.dlp.com
DSP	dsp.ti.com
Clocks and Timers	www.ti.com/clocks
Interface	interface.ti.com
Logic	logic.ti.com
Power Mgmt	power.ti.com
Microcontrollers	microcontroller.ti.com
RFID	www.ti-rfid.com
OMAP Applications Processors	www.ti.com/omap
Wireless Connectivity	www.ti.com/wirelessconnectivity

Applications

Automotive and Transportation	www.ti.com/automotive
Communications and Telecom	www.ti.com/communications
Computers and Peripherals	www.ti.com/computers
Consumer Electronics	www.ti.com/consumer-apps
Energy and Lighting	www.ti.com/energy
Industrial	www.ti.com/industrial
Medical	www.ti.com/medical
Security	www.ti.com/security
Space, Avionics and Defense	www.ti.com/space-avionics-defense
Video and Imaging	www.ti.com/video

TI E2E Community

e2e.ti.com

Looking for pricing, stock, or lifecycle information?

Click below to explore more details on WIN SOURCE:

 [View SM470R1B1MHFQS on WIN SOURCE](#)

 [Texas Instruments](#) Information

Optimize Your Supply Chain with WIN SOURCE Solutions

-  Global Sourcing Solution
-  Obsolete Management
-  Cost Control Management
-  Shortage Management
-  Alternative Solution
-  Excess Inventory Management