



**THE DATASHEET OF  
FXGL2014MTCX**



# ON Semiconductor

## Is Now

# onsemi™

To learn more about onsemi™, please visit our website at  
[www.onsemi.com](http://www.onsemi.com)

---

**onsemi** and **onsemi** and other names, marks, and brands are registered and/or common law trademarks of Semiconductor Components Industries, LLC dba "**onsemi**" or its affiliates and/or subsidiaries in the United States and/or other countries. **onsemi** owns the rights to a number of patents, trademarks, copyrights, trade secrets, and other intellectual property. A listing of **onsemi** product/patent coverage may be accessed at [www.onsemi.com/site/pdf/Patent-Marking.pdf](http://www.onsemi.com/site/pdf/Patent-Marking.pdf). **onsemi** reserves the right to make changes at any time to any products or information herein, without notice. The information herein is provided "as-is" and **onsemi** makes no warranty, representation or guarantee regarding the accuracy of the information, product features, availability, functionality, or suitability of its products for any particular purpose, nor does **onsemi** assume any liability arising out of the application or use of any product or circuit, and specifically disclaims any and all liability, including without limitation special, consequential or incidental damages. Buyer is responsible for its products and applications using **onsemi** products, including compliance with all laws, regulations and safety requirements or standards, regardless of any support or applications information provided by **onsemi**. "Typical" parameters which may be provided in **onsemi** data sheets and/or specifications can and do vary in different applications and actual performance may vary over time. All operating parameters, including "Typicals" must be validated for each customer application by customer's technical experts. **onsemi** does not convey any license under any of its intellectual property rights nor the rights of others. **onsemi** products are not designed, intended, or authorized for use as a critical component in life support systems or any FDA Class 3 medical devices or medical devices with a same or similar classification in a foreign jurisdiction or any devices intended for implantation in the human body. Should Buyer purchase or use **onsemi** products for any such unintended or unauthorized application, Buyer shall indemnify and hold **onsemi** and its officers, employees, subsidiaries, affiliates, and distributors harmless against all claims, costs, damages, and expenses, and reasonable attorney fees arising out of, directly or indirectly, any claim of personal injury or death associated with such unintended or unauthorized use, even if such claim alleges that **onsemi** was negligent regarding the design or manufacture of the part. **onsemi** is an Equal Opportunity/Affirmative Action Employer. This literature is subject to all applicable copyright laws and is not for resale in any manner. Other names and brands may be claimed as the property of others.



Is Now Part of



**ON Semiconductor®**

To learn more about ON Semiconductor, please visit our website at  
[www.onsemi.com](http://www.onsemi.com)

Please note: As part of the Fairchild Semiconductor integration, some of the Fairchild orderable part numbers will need to change in order to meet ON Semiconductor's system requirements. Since the ON Semiconductor product management systems do not have the ability to manage part nomenclature that utilizes an underscore (\_), the underscore (\_) in the Fairchild part numbers will be changed to a dash (-). This document may contain device numbers with an underscore (\_). Please check the ON Semiconductor website to verify the updated device numbers. The most current and up-to-date ordering information can be found at [www.onsemi.com](http://www.onsemi.com). Please email any questions regarding the system integration to [Fairchild\\_questions@onsemi.com](mailto:Fairchild_questions@onsemi.com).

ON Semiconductor and the ON Semiconductor logo are trademarks of Semiconductor Components Industries, LLC dba ON Semiconductor or its subsidiaries in the United States and/or other countries. ON Semiconductor owns the rights to a number of patents, trademarks, copyrights, trade secrets, and other intellectual property. A listing of ON Semiconductor's product/patent coverage may be accessed at [www.onsemi.com/site/pdf/Patent-Marking.pdf](http://www.onsemi.com/site/pdf/Patent-Marking.pdf). ON Semiconductor reserves the right to make changes without further notice to any products herein. ON Semiconductor makes no warranty, representation or guarantee regarding the suitability of its products for any particular purpose, nor does ON Semiconductor assume any liability arising out of the application or use of any product or circuit, and specifically disclaims any and all liability, including without limitation special, consequential or incidental damages. Buyer is responsible for its products and applications using ON Semiconductor products, including compliance with all laws, regulations and safety requirements or standards, regardless of any support or applications information provided by ON Semiconductor. "Typical" parameters which may be provided in ON Semiconductor data sheets and/or specifications can and do vary in different applications and actual performance may vary over time. All operating parameters, including "Typicals" must be validated for each customer application by customer's technical experts. ON Semiconductor does not convey any license under its patent rights nor the rights of others. ON Semiconductor products are not designed, intended, or authorized for use as a critical component in life support systems or any FDA Class 3 medical devices or medical devices with a same or similar classification in a foreign jurisdiction or any devices intended for implantation in the human body. Should Buyer purchase or use ON Semiconductor products for any such unintended or unauthorized application, Buyer shall indemnify and hold ON Semiconductor and its officers, employees, subsidiaries, affiliates, and distributors harmless against all claims, costs, damages, and expenses, and reasonable attorney fees arising out of, directly or indirectly, any claim of personal injury or death associated with such unintended or unauthorized use, even if such claim alleges that ON Semiconductor was negligent regarding the design or manufacture of the part. ON Semiconductor is an Equal Opportunity/Affirmative Action Employer. This literature is subject to all applicable copyright laws and is not for resale in any manner.



ON Semiconductor®

September 2018

# FXGL2014 — 4-Channel LVTTTL to GTL Transceiver

## Features

- Operates as a 4-bit GTL-/GTL/GTL+ Sampling receiver or as a LVTTTL to GTL-/GTL/GTL+ Driver
- 3.0 V to 3.6 V Operation with 5 V Tolerant LVTTTL Input
- GTL Input and Output 3.6 V Tolerant
- Vref Adjustable from 0.5 V to VCC/2
- Partial Power-down Permitted
- Under-Voltage Lockout (UVLO)
- ESD Protection exceeds 2000 V HBM per JESD22-A114 and 1000 V CDM per JESD22-CC101
- Latch-up Protection Exceeds 500 mA per JESD78
- Package Offered: TSSOP14
- -40°C to 85°C Operating Temperature Range

## Description

The FXGL2014 is a 4-channel translator to interface between 3.3-V LVTTTL chip set I/O and Xeon processor GTL-/GTL/GTL+ I/O.

The FXGL2014 integrates ESD protection cells on all terminals and is available in a TSSOP package (5.0 mm x 4.4 mm). The device is characterized over free air temperature range of -40°C to 85°C.

## Applications

- Server
- Base Station
- Wire-line Communication

## Ordering Information

Part Number	Operating Temperature Range	Package	Packing Method
FXGL2014MTCX	-40 to +85°C	5.0 mm x 4.4 mm, 0.65 mm Pitch, 14 Lead TSSOP Package	Tape & Reel

FXGL2014 — 4-Channel LVTTTL to GTL Transceiver

## Analog Symbols

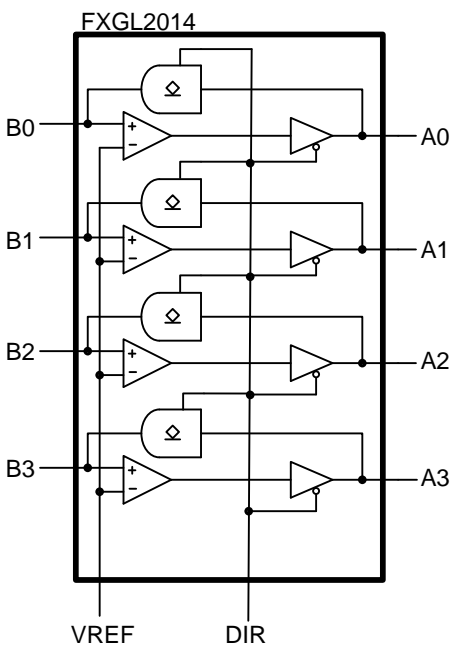

Figure 1. Analog Symbols

## Functional Description

INPUT	INPUT/OUTPUT	
	A (LVTTTL)	B (GTL)
DIR		
High Voltage	Input	$B_n = A_n$
Low Voltage	$A_n = B_n$	Input

## Pin Configuration

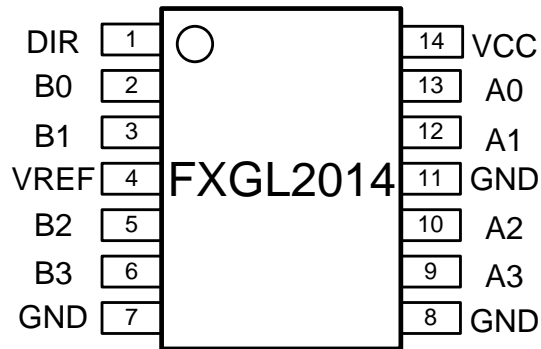

Figure 1. Pin Assignment (Top Through View)

## Pin Descriptions

Pin Name	Pin #	Description
A0	13	LVTTTL Data Input / Output
A1	12	
A2	10	
A3	9	
B0	2	GTL Data Input / Output
B1	3	
B2	5	
B3	6	
DIR	1	Direction Control Input (LVTTTL)
GND	7	Ground
	8	
	11	
VCC	14	Supply Voltage
VREF	4	GTL Reference Voltage

## Absolute Maximum Ratings

Stresses exceeding the absolute maximum ratings may damage the device. The device may not function or be operable above the recommended operating conditions and stressing the parts to these levels is not recommended. In addition, extended exposure to stresses above the recommended operating conditions may affect device reliability. The absolute maximum ratings are stress ratings only.

Symbol	Parameter		Min.	Max.	Unit
$V_{CC}$	Supply Voltage		-0.5	4.6	V
$I_{IK}$	Input Clamping Current, $V_I < 0$ V			-50	mA
$V_{DIR}$	Input Control Voltages DIR		-0.5	6	V
$V_I$	Input Voltage	A Port	-0.5	6.5	V
		B Port	-0.5	4.6	
$I_{CK}$	Control Input Clamp Current, $V_O < 0$ V			-50	mA
$V_O$	Output Voltage in Off-State	A Port	-0.5	6.5	V
		B Port	-0.5	4.6	
$I_{OL}$	Current into any output in the Low State	A Port		40	mA
		B Port		80	
$I_{OH}$	Current into any output in the High State			-40	mA
$T_{stg}$	Storage Temperature Range		-55	150	°C
$V_{ESD}$	Human Body Model (HBM), JEDEC: JESD22-A114	All Pins	2		kV
	Charged Device Model, JEDEC: JESD22-C101	All Pins	1		

## Recommended Operating Conditions

The Recommended Operating Conditions table defines the conditions for actual device operation. Recommended operating conditions are specified to ensure optimal performance. ON does not recommend exceeding them or designing to Absolute Maximum Ratings.

Symbol	Parameter		Min.	Typ.	Max.	Unit
$V_{CC}$	Supply Voltage		3.0	3.3	3.6	V
$V_{TT}$	Termination Voltage	GTL-	0.85	0.90	0.95	V
		GTL	1.14	1.20	1.26	
		GTL+	1.35	1.50	1.65	
$V_{REF}$	Reference Voltage	Overall	0.5	$2/3V_{TT}$	$V_{CC}/2$	V
		GTL-	0.50	0.60	0.63	
		GTL	0.76	0.80	0.84	
		GTL+	0.87	1.00	1.10	
$V_I$	Input Voltage	A Port	0	3.3	$5.5^{(3)}$	V
		B Port	0	$V_{TT}$	3.6	
$V_{IH}$	High-level Input Voltage	A Port and DIR	2			V
		B Port	$V_{REF} + 50 \text{ mV}$			
$V_{IL}$	Low-level Input Voltage	A Port and DIR			0.8	V
		B Port			$V_{REF} - 50 \text{ mV}$	
$I_{OL}$	Low-level Output Current	A Port			20	mA
		B Port			50	
$I_{OH}$	High-level Output current	A Port			-20	mA

### Notes:

1. Over operating free-air temperature range (unless otherwise noted).
2. All unused control inputs of the device must be held at  $V_{CC}$  or GND to ensure proper device operation.
3. The  $V_I$  (max) of LVTTTL port is 3.6 V if configured as output (DIR=L).

## Thermal Information

Thermal Metric		Value	Unit
$R_{\theta JA}$	Junction-to-Ambient Thermal Resistance	116	°C/W
$R_{\theta JC(top)}$	Junction-to-Case (top) Thermal Resistance	17	

## DC Electrical Characteristics

Specified at  $T_A = -40^\circ\text{C}$  to  $85^\circ\text{C}$  (unless otherwise noted).

Symbol	Parameter	Conditions	-40°C to 85°C			Unit
			Min.	Typ.	Max.	
$V_{OH}$	A Port	$V_{CC} = 3$ to $3.6$ V, $I_{OH} = -100$ $\mu\text{A}$	$V_{CC} - 0.2$			V
		$V_{CC} = 3$ V, $I_{OH} = -16$ mA	2.0			
$V_{OL}$	A Port	$V_{CC} = 3$ V, $I_{OL} = 8$ mA		0.28	0.40	V
	A Port	$V_{CC} = 3$ V, $I_{OL} = 12$ mA		0.42	0.60	
	A Port	$V_{CC} = 3$ V, $I_{OL} = 16$ mA		0.55	0.80	
	B Port	$V_{CC} = 3$ V, $I_{OL} = 40$ mA		0.23	0.40	
$I_I$	A Port	$V_{CC} = 3.6$ V, $V_I = V_{CC}$			$\pm 1$	$\mu\text{A}$
		$V_{CC} = 3.6$ V, $V_I = 0$ V			$\pm 1$	
		$V_{CC} = 3.6$ V, $V_I = 5.5$ V			5	
	B Port	$V_{CC} = 3.6$ V, $V_I = V_{TT}$ or GND			$\pm 1$	$\mu\text{A}$
Control Pin	$V_{CC} = 3.6$ V, $V_I = V_{CC}$ or 0 V			$\pm 1$	$\mu\text{A}$	
$I_{off}$	OFF-State Output Current on A Port	$V_{CC} = 0$ V, $V_{IO} = 0$ to $3.6$ V			$\pm 10$	$\mu\text{A}$
	OFF-State Output Current on A Port	$V_{CC} = 0$ V, $V_{IO} = 3.6$ to $5.5$ V			$\pm 100$	
	OFF-State Output Current on B Port	$V_{CC} = 0$ V, $V_{IO} = 0$ to $3.6$ V			$\pm 10$	
$I_{CC}$	A Port	$V_{CC} = 3.6$ V, $V_I = V_{CC}$ or GND, $I_O = 0$		3	10	mA
	B Port	$V_{CC} = 3.6$ V, $V_I = V_{TT}$ or GND, $I_O = 0$		3	10	mA
$\Delta I_{CC}$	A Port or Control Input	$V_{CC} = 3.6$ V, $V_I = V_{CC} - 0.6$ V			500	$\mu\text{A}$
$V_{UVLO}^{(4)}$	Under-Voltage Lockout Threshold	$V_{CC} = 0$ to $3$ V	1.5			V
$C_I^{(4)}$	Input Capacitance of Control Pin	$V_{CC} = 3$ to $3.6$ V, $V_I = 3.0$ V or 0 V		2.0		pF
$C_{IO}^{(4)}$	A Port	$V_{CC} = 3$ to $3.6$ V, $V_O = 3.0$ V or 0 V		4.0		pF
	B Port	$V_{CC} = 3$ to $3.6$ V, $V_O = V_{TT}$ or 0 V		5.46		

**Note:**

4. Guaranteed by characterization and / or design. Not production tested.

## AC Electrical Characteristics

Over-operating range,  $T_A = -40^{\circ}\text{C}$  to  $85^{\circ}\text{C}$ ,  $V_{CC} = 3.0$  to  $3.6$  V,  $GND = 0$  V for GTL.

Symbol	Parameter		GTL-			GTL			GTL+			Unit
			$V_{CC} = 3.3\text{ V} \pm 0.3\text{ V}$			$V_{CC} = 3.3\text{ V} \pm 0.3\text{ V}$			$V_{CC} = 3.3\text{ V} \pm 0.3\text{ V}$			
			$V_{REF} = 0.6\text{ V}$			$V_{REF} = 0.8\text{ V}$			$V_{REF} = 1\text{ V}$			
			$V_{TT} = 0.9\text{ V}$			$V_{TT} = 1.2\text{ V}$			$V_{TT} = 1.5\text{ V}$			
			Min.	Typ.	Max.	Min.	Typ.	Max.	Min.	Typ.	Max.	
$t_{PLH}$	Low to High Propagation Delay <sup>(5)</sup>	An to Bn		2.8	5.0		2.8	5.0		2.8	5.0	ns
$t_{PHL}$	High to Low Propagation Delay <sup>(5)</sup>			3.3	7.0		3.4	7.0		3.4	7.0	
$t_{PLH}$	Low to High Propagation Delay <sup>(5)</sup>	Bn to An		5.3	8.0		5.2	8.0		5.1	8.0	ns
$t_{PHL}$	High to Low Propagation Delay <sup>(5)</sup>			5.2	8.0		4.9	7.0		4.7	7.0	

**Note:**

- Guaranteed by characterization and / or design. Not production tested.

### Typical characteristics

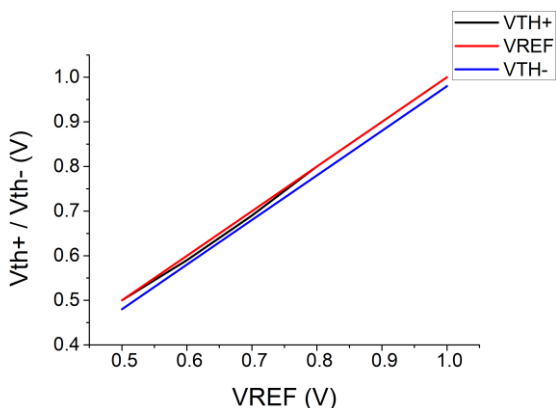

Figure 2. GTL Vth+ and Vth- vs. VREF (-40°C)

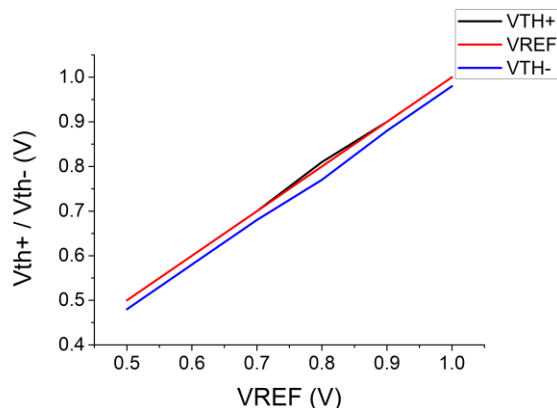

Figure 3. GTL Vth+ and Vth- vs. VREF (25°C)

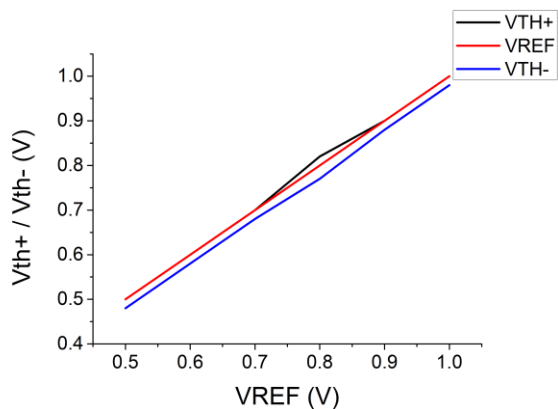
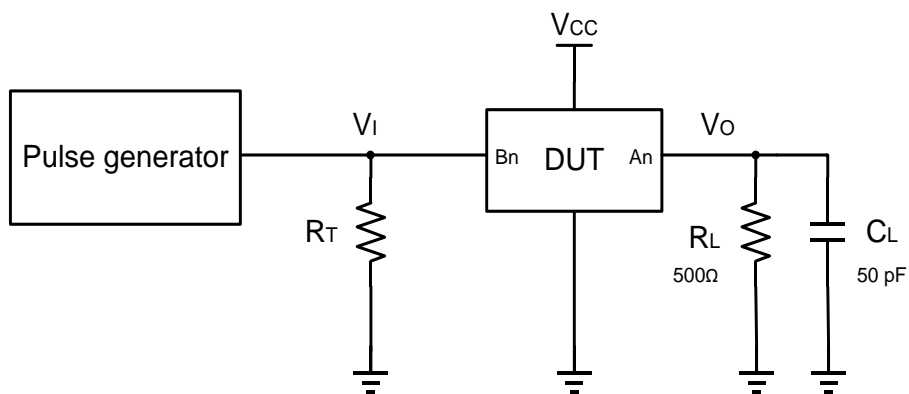
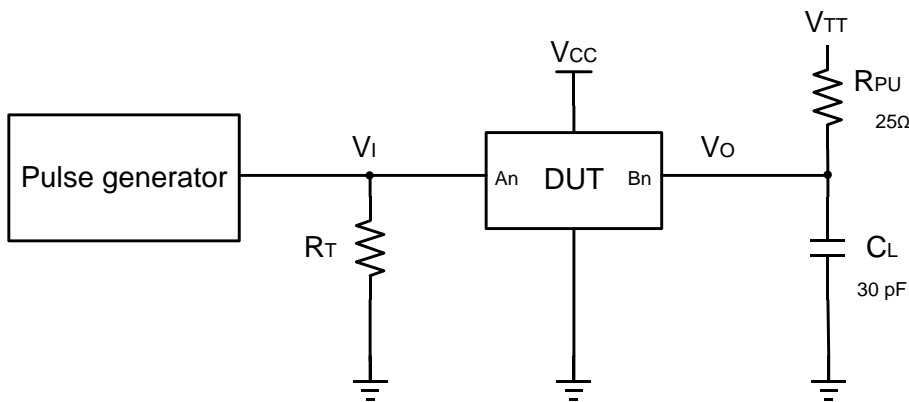

Figure 4. GTL Vth+ and Vth- vs. VREF (85°C)

### Test Information



**Figure 5. Load Circuit for A Port**



**Figure 6. Load Circuit for B Port**

$R_T$  - Termination resistance; should be equal to output impedance of pulse generators.

$R_L$  - Load resistor.

$C_L$  - Load capacitance; includes jig and probe capacitance.

### Waveforms

$V_M = 1.5\text{ V}$  at  $V_{CC} \geq 3.0\text{ V}$ ;  $V_M = V_{CC}$  at  $V_{CC} \leq 2.7\text{ V}$  for A ports and control pins.

$V_M = V_{REF}$  for B ports.

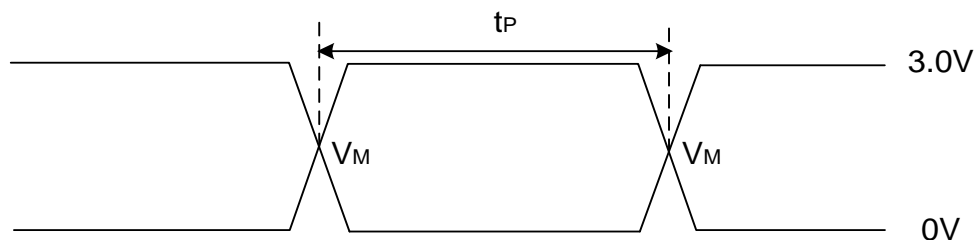

$V_M = 1.5\text{V}$  for A port and  $V_{REF}$  for B port

#### Pulse duration

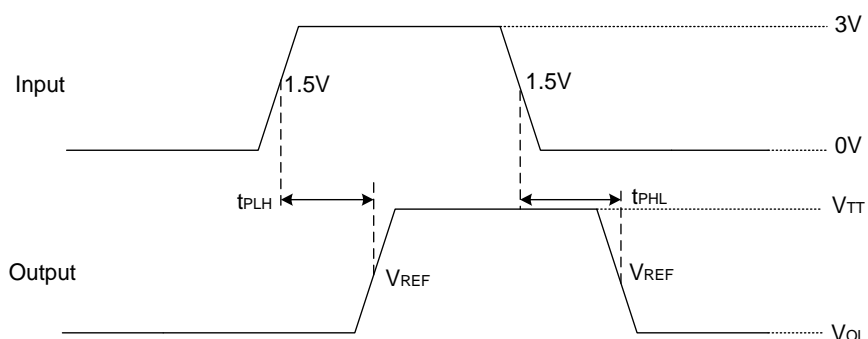

A port to B port

#### Propagation delay times

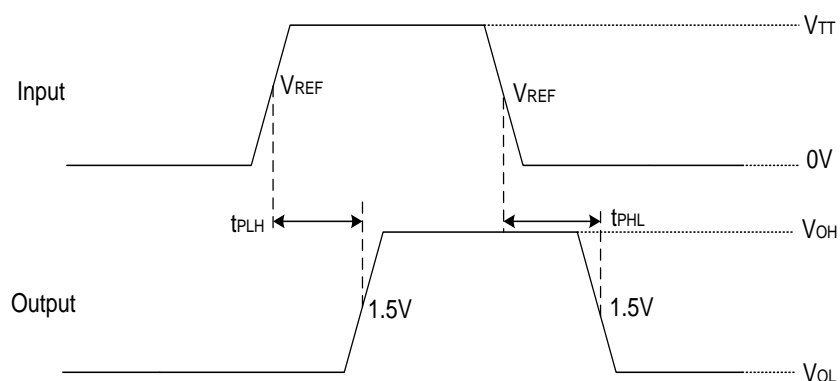

B port to A port

#### Propagation delay times

**Figure 7. Voltage Waveforms**

- A. All control inputs are LVTTTL levels.
- B.  $C_L$  includes probe and jig capacitance.
- C. All input pulses are supplied by generators having the following characteristics:  $PRR \leq 10\text{ MHz}$ ,  $Z_O = 50\ \Omega$ ,  $t_r \leq 2.5\text{ ns}$ ,  $t_f \leq 2.5\text{ ns}$ .
- D. The outputs are measured one at a time, with one transition per measurement.

## Application Information

### Application Overview

The FXGL2014 is a 4-channel translating transceiver designed for 3.3-V LVTTTL system interface with a GTL–/GTL/GTL+ bus, where GTL–/GTL/GTL+ refers to the reference voltage of the GTL bus and the input/output voltage thresholds associated with it.

The direction pin allows the part to function as either a GTL-to-LVTTTL sampling receiver or as a LVTTTL-to-GTL interface.

The FXGL2014 performs translation in two directions. One direction is GTL–/GTL/GTL+ to LVTTTL when DIR is tied to GND. With appropriate  $V_{REF}$  set up, the GTL input can be compliant with GTL–/GTL/GTL+. Another direction is LVTTTL to GTL–/GTL/GTL+ when DIR is tied to VCC. 3.6 V tolerance on the GTL output allows the GTL outputs to pull up to any voltage level under 3.6 V.

### Feature Description

#### 5 V Tolerance on LVTTTL Input

The FXGL2014 LVTTTL inputs (only) are tolerant up to 5.5 V and allow direct access to TTL or 5 V CMOS inputs. The LVTTTL outputs are not 5.5 V tolerant.

#### 3.6 V Tolerance on GTL Input / Output

The FXGL2014 GTL inputs and outputs operate up to 3.6 V, allowing the device to be used in higher voltage open-drain output applications.

#### Ultra-Low $V_{REF}$ and High Bandwidth

FXGL2014's  $V_{REF}$  tracks down to 0.5 V for low voltage CPUs with excellent propagation delay performance. This feature allows the FXGL2014 to support high data rates with the GTL– bus.

#### Under-Voltage Lockout (UVLO)

Under-voltage lockout circuit is integrated internal. This feature makes sure the data transferred effectively when power unstable.

### Typical Application

#### GTL–/GTL/GTL+ to LVTTTL

Select appropriate  $V_{TT}/V_{REF}$  based upon GTL–/GTL/GTL+. The parameters in Recommended Operating Conditions are compliant to the GTL specification.

The FXGL2014 requires industrial standard LVTTTL and GTL inputs. The design example in the Application Information shows standard voltage level and typical resistor values.

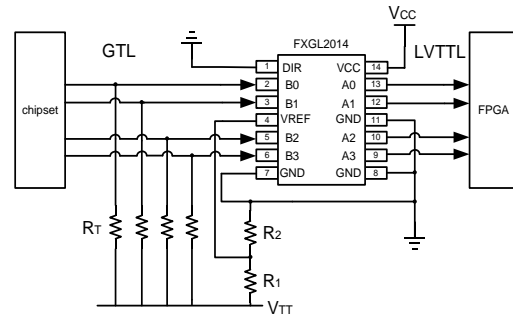

**Figure 8. Application Diagram for GTL to LVTTTL**

**Table 1. Application Table for GTL to LVTTTL**

	Port B to Port A GTL to LVTTTL
VCC	3.3 V
VREF	$2 \cdot V_{TT} / 3$
VTT	1.0 V
DIR	GND
RT	75 $\Omega$
R1	49.9 $\Omega$
R2	100 $\Omega$

#### LVTTTL to GTL–/GTL/GTL+

Because GTL is an open-drain interface, the selection of the pull-up resistor depends on the application requirement (for example, data rate) and PCB trace capacitance.

The FXGL2014 requires industrial standard LVTTTL and GTL inputs. The design example in the Application Information section show standard voltage level and typical resistor values.

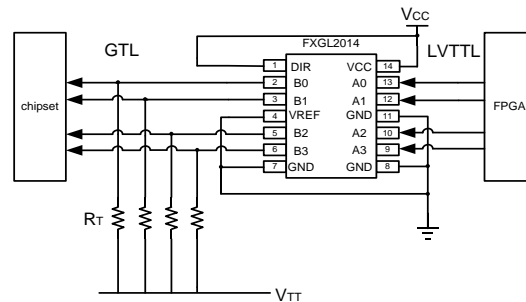

**Figure 9. Application Diagram for LVTTTL to GTL**

**Table 2. Application Table for LVTTTL to GTL**

	Port A to Port B LVTTTL to GTL
VCC	3.3 V
VREF	GND
VTT	1.0 V
DIR	GND
RT	75 $\Omega$
R1	Not Available
R2	Not Available

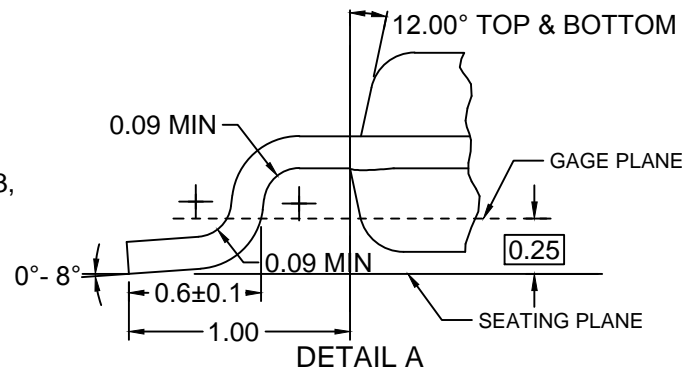
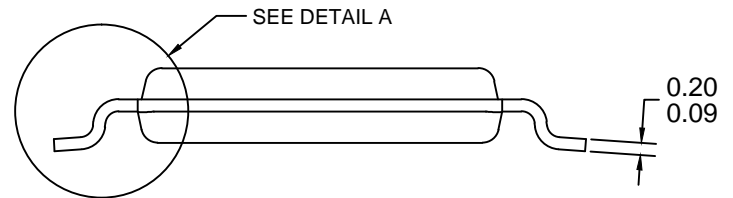
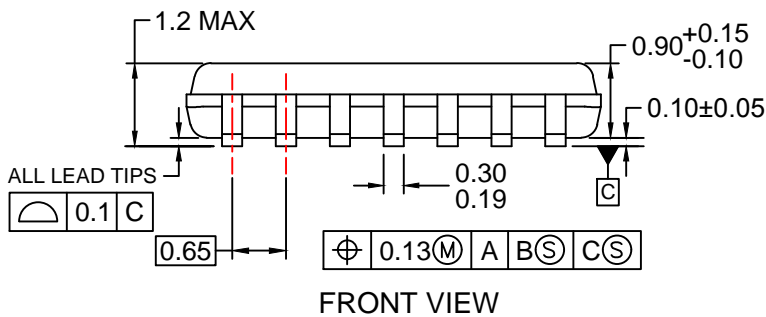
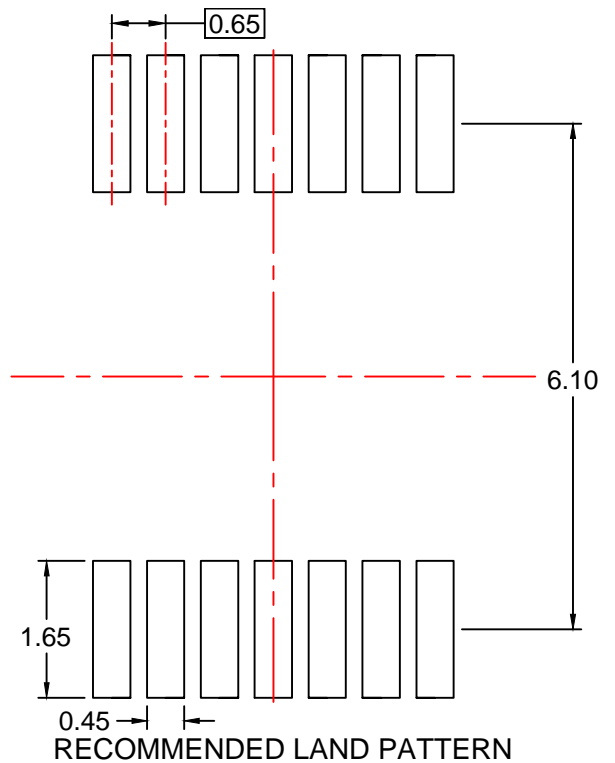
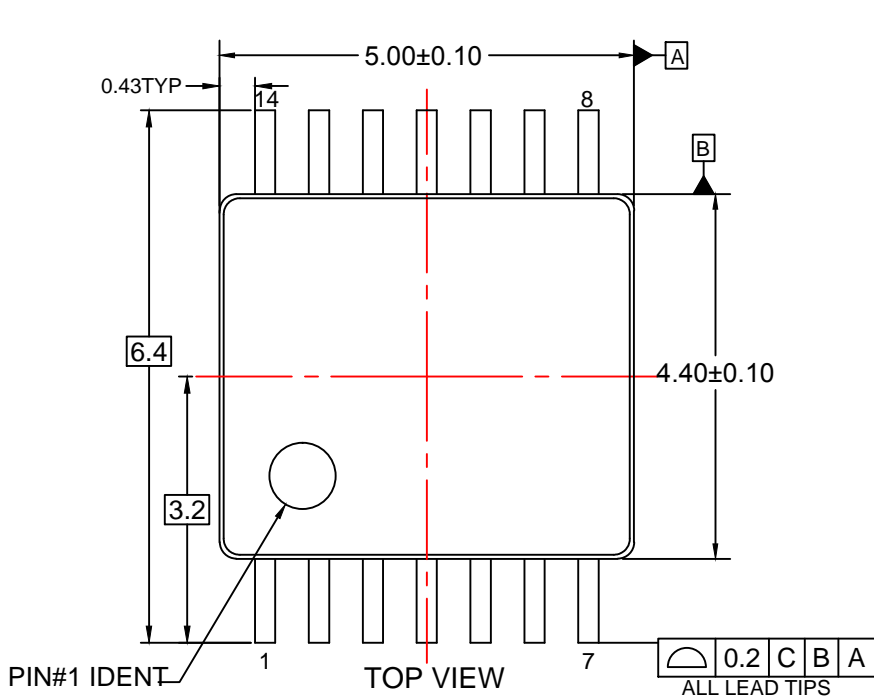

NOTES:

- A. CONFORMS TO JEDEC REGISTRATION MO-153, VARIATION AB, REF NOTE 6
- B. DIMENSIONS ARE IN MILLIMETERS.
- C. DIMENSIONS ARE EXCLUSIVE OF BURRS, MOLD FLASH, AND TIE BAR EXTRUSIONS
- D. DIMENSIONING AND TOLERANCES PER ANSI Y14.5M, 2009.
- E. LANDPATTERN STANDARD: SOP65P640X110-14M.
- F. DRAWING FILE NAME: MKT-MTC14rev7.

ON Semiconductor and  are trademarks of Semiconductor Components Industries, LLC dba ON Semiconductor or its subsidiaries in the United States and/or other countries. ON Semiconductor owns the rights to a number of patents, trademarks, copyrights, trade secrets, and other intellectual property. A listing of ON Semiconductor's product/patent coverage may be accessed at [www.onsemi.com/site/pdf/Patent-Marking.pdf](http://www.onsemi.com/site/pdf/Patent-Marking.pdf). ON Semiconductor reserves the right to make changes without further notice to any products herein. ON Semiconductor makes no warranty, representation or guarantee regarding the suitability of its products for any particular purpose, nor does ON Semiconductor assume any liability arising out of the application or use of any product or circuit, and specifically disclaims any and all liability, including without limitation special, consequential or incidental damages. Buyer is responsible for its products and applications using ON Semiconductor products, including compliance with all laws, regulations and safety requirements or standards, regardless of any support or applications information provided by ON Semiconductor. "Typical" parameters which may be provided in ON Semiconductor data sheets and/or specifications can and do vary in different applications and actual performance may vary over time. All operating parameters, including "Typicals" must be validated for each customer application by customer's technical experts. ON Semiconductor does not convey any license under its patent rights nor the rights of others. ON Semiconductor products are not designed, intended, or authorized for use as a critical component in life support systems or any FDA Class 3 medical devices or medical devices with a same or similar classification in a foreign jurisdiction or any devices intended for implantation in the human body. Should Buyer purchase or use ON Semiconductor products for any such unintended or unauthorized application, Buyer shall indemnify and hold ON Semiconductor and its officers, employees, subsidiaries, affiliates, and distributors harmless against all claims, costs, damages, and expenses, and reasonable attorney fees arising out of, directly or indirectly, any claim of personal injury or death associated with such unintended or unauthorized use, even if such claim alleges that ON Semiconductor was negligent regarding the design or manufacture of the part. ON Semiconductor is an Equal Opportunity/Affirmative Action Employer. This literature is subject to all applicable copyright laws and is not for resale in any manner.

## PUBLICATION ORDERING INFORMATION

### LITERATURE FULFILLMENT:

Literature Distribution Center for ON Semiconductor  
19521 E. 32nd Pkwy, Aurora, Colorado 80011 USA  
**Phone:** 303-675-2175 or 800-344-3860 Toll Free USA/Canada  
**Fax:** 303-675-2176 or 800-344-3867 Toll Free USA/Canada  
**Email:** [orderlit@onsemi.com](mailto:orderlit@onsemi.com)

**N. American Technical Support:** 800-282-9855 Toll Free  
USA/Canada  
**Europe, Middle East and Africa Technical Support:**  
Phone: 421 33 790 2910

**ON Semiconductor Website:** [www.onsemi.com](http://www.onsemi.com)

**Order Literature:** <http://www.onsemi.com/orderlit>

For additional information, please contact your local  
Sales Representative

## Looking for pricing, stock, or lifecycle information?

Click below to explore more details on WIN SOURCE:

 [View FXGL2014MTCX on WIN SOURCE](#)

 [ON Semiconductor](#) Information

## Optimize Your Supply Chain with WIN SOURCE Solutions

-  Global Sourcing Solution
-  Obsolete Management
-  Cost Control Management
-  Shortage Management
-  Alternative Solution
-  Excess Inventory Management