



**THE DATASHEET OF  
SN65LVDS304ZQER**



## PROGRAMMABLE 27-BIT SERIAL-TO-PARALLEL RECEIVER

### FEATURES

- **Serial Interface Technology**
- **Compatible With FlatLink™3G Such as SN65LVDS303**
- **Supports Video Interfaces up to 24-Bit RGB Data and 3 Control Bits Received Over 1 or 2 SubLVDS Differential Lines**
- **SubLVDS Differential Voltage Levels**
- **Up to 810-Mbps Data Throughput**
- **Three Operating Modes to Conserve Power**
  - Active mode QVGA: 17 mW
  - Typical Shutdown: 0.7 µW
  - Typical Standby Mode: 27 µW Typical
- **Bus-Swap Function for PCB-Layout Flexibility**
- **ESD Rating > 4 kV (HBM)**
- **Pixel Clock Range of 4 MHz–30 MHz**
- **Failsafe on all CMOS Inputs**
- **Packaged in 5-mm × 5-mm MicroStar Junior µBGA® With 0,5-mm Ball Pitch**
- **Very Low EMI Meets SAE J1752/3 'Kh'-Spec**

### APPLICATIONS

- **Small Low-Emission Interface Between Graphics Controller and LCD Display**
- **Mobile Phones and Smart Phones**
- **Portable Multimedia Players**

### DESCRIPTION

The SN65LVDS304 receiver deserializes FlatLink™3G-compliant serial input data to 27 parallel data outputs. The SN65LVDS304 receiver contains one shift register to load 30 bits from 1 or 2 serial inputs and latches the 24 pixel bits and 3 control bits out to the parallel CMOS outputs after checking the parity bit. If the parity check confirms correct parity, the channel parity error (CPE) output remains low. If a parity error is detected, the CPE output generates a high pulse while the data output bus disregards the newly-received pixel. Instead, the last data word is held on the output bus for another clock cycle.

The serial data and clock are received via sub-low-voltage differential signalling (SubLVDS) lines. The SN65LVDS304 supports three operating power modes (shutdown, standby, and active) to conserve power.

When receiving, the PLL locks to the incoming clock CLK and generates an internal high-speed clock at the line rate of the data lines. The data is serially loaded into a shift register using the internal high-speed clock. The deserialized data is presented on the parallel output bus with a recreation of the pixel clock, PCLK, generated from the internal high-speed clock. If no input CLK signal is present, the output bus is held static with PCLK and DE held low, while all other parallel outputs are pulled high.

The parallel (CMOS) output bus offers a bus-swap feature. The SWAP control pin controls the output pin order of the output pixel data to be either R[7:0], G[7:0], B[7:0], VS, HS, DE or B[0:7], G[0:7], R[0:7], VS, HS, DE. This gives a PCB designer the flexibility to better match the bus to the LCD driver pinout or to put the receiver device on the top side or the bottom side of the PCB. The F/S control input selects between a slow CMOS bus output rise time for best EMI and power consumption and a fast CMOS output for increased speed or higher-load designs.

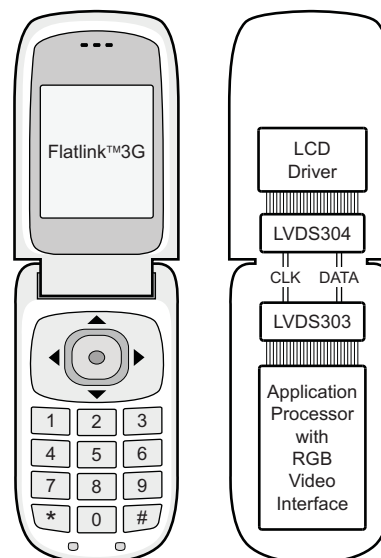

M0056-01



Please be aware that an important notice concerning availability, standard warranty, and use in critical applications of Texas Instruments semiconductor products and disclaimers thereto appears at the end of this data sheet.

FlatLink is a trademark of Texas Instruments.  
µBGA is a registered trademark of Tesser, Inc.



These devices have limited built-in ESD protection. The leads should be shorted together or the device placed in conductive foam during storage or handling to prevent electrostatic damage to the MOS gates.

## DESCRIPTION (CONTINUED)

The link select line, LS, selects whether 1 or 2 serial links are used. The RXEN input can be used to put the SN65LVDS304 in a shutdown mode. The SN65LVDS304 enters an active standby mode if the common mode voltage of the CLK input becomes shifted to  $V_{DDLVDs}$  (e.g., transmitter releases CLK output into high-impedance). This minimizes power consumption without the need of switching an external control pin. The SN65LVDS304 is characterized for operation over ambient air temperatures of  $-40^{\circ}\text{C}$  to  $85^{\circ}\text{C}$ . All CMOS and SubLVDS signals are 2-V tolerant with  $V_{DD} = 0\text{ V}$ . This feature allows signal powerup before  $V_{CC}$  is stabilized.

## FUNCTIONAL BLOCK DIAGRAM

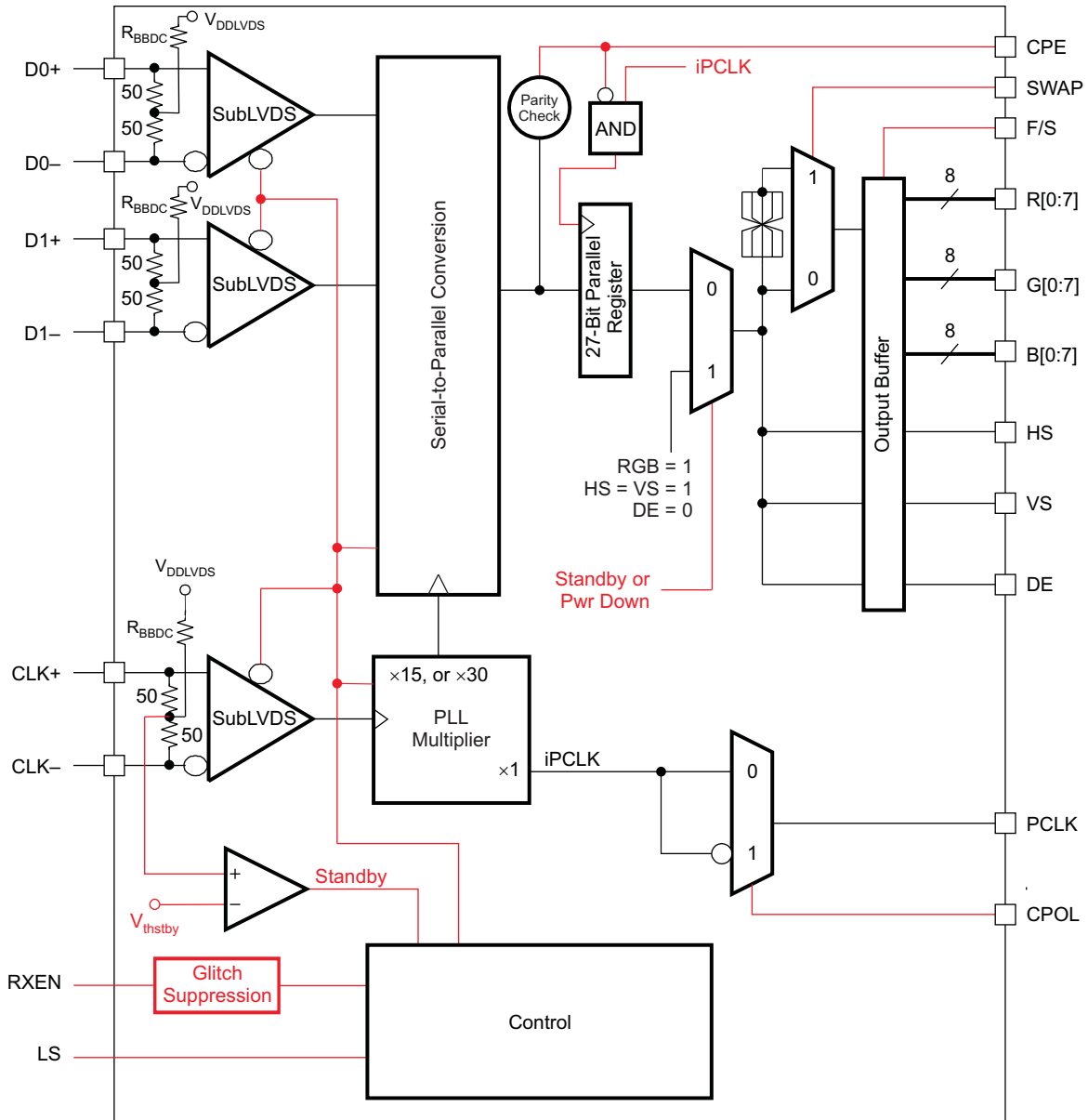

B0177-01

PINOUT – TOP VIEW

ZQE PACKAGE  
(TOP VIEW)

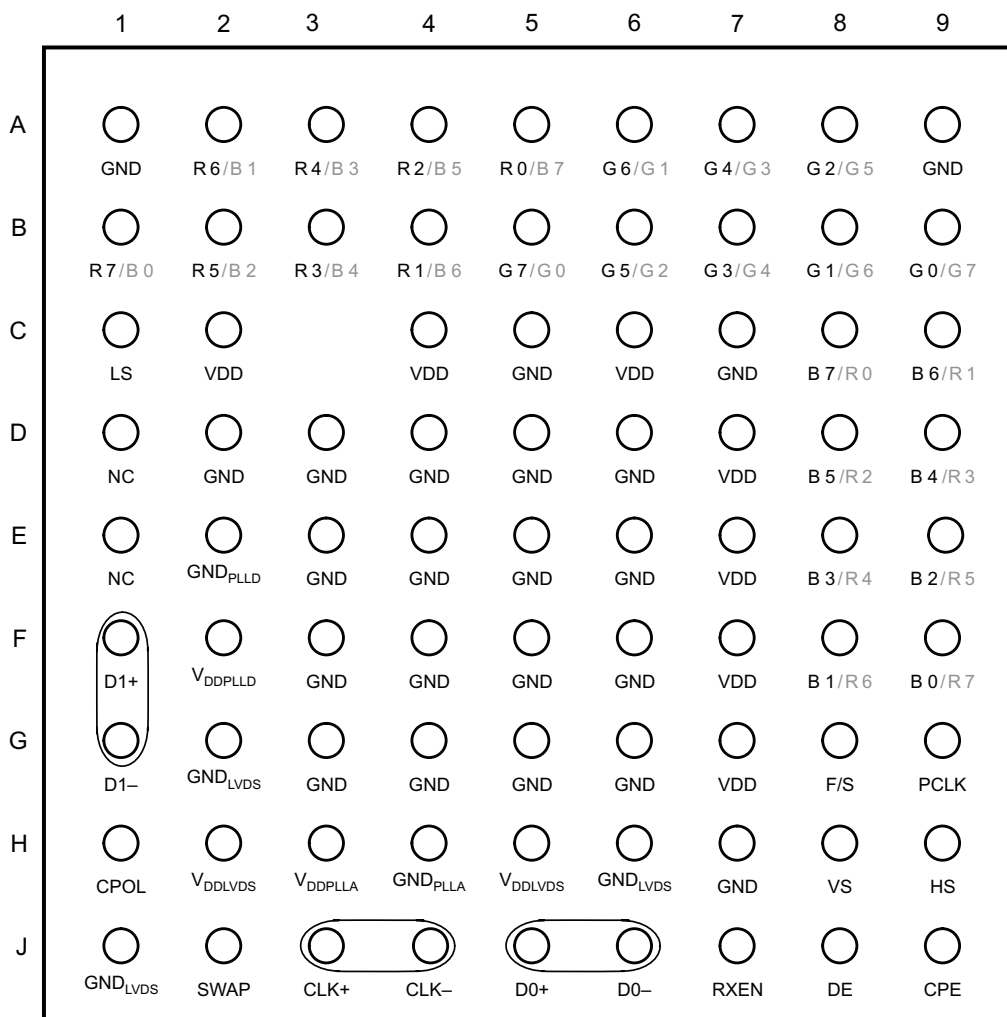

RGB Output pin assignment based on SWAP pin setting:  
SWAP = 0 / SWAP = 1

P0049-01

PINOUT – TOP VIEW (continued)

SWAP PIN FUNCTIONALITY

The SWAP pin allows the pcb designer to reverse the RGB bus, minimizing potential signal crossovers due to signal routing. The two drawings beneath show the RGB signal pin assignment based on the SWAP-pin setting.

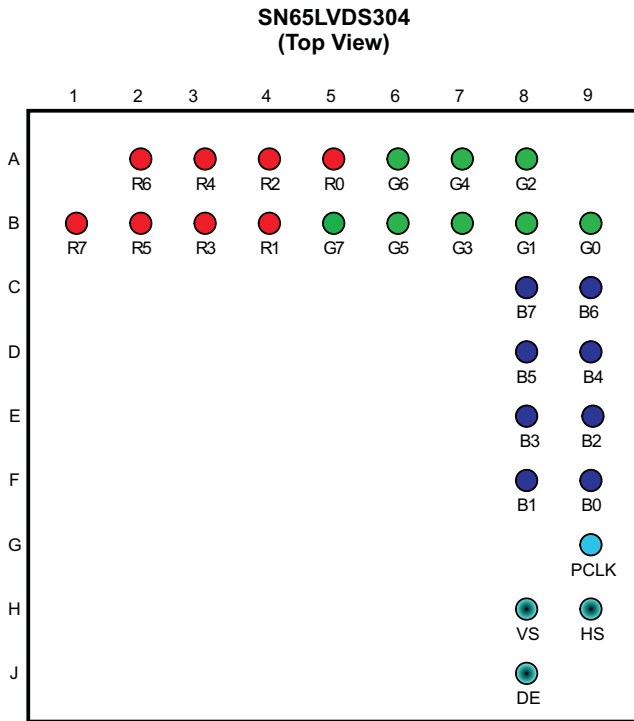

P0049-02

Figure 1. Pinout With SWAP PIN = GND

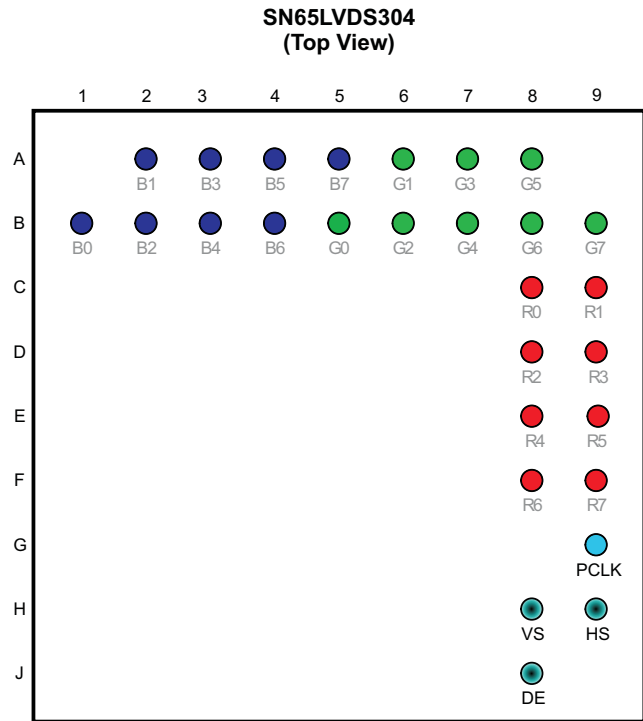

P0049-03

Figure 2. Pinout With SWAP PIN = V<sub>DD</sub>

**PINOUT – TOP VIEW (continued)**

**Table 1. Pin Description**

PIN	SWAP	SIGNAL	PIN	SWAP	SIGNAL	PIN	SWAP	SIGNAL
A1	–	GND	C1	–	LS	F1	–	D1+
A2	L	R6	C2	–	V <sub>DD</sub>	F2	–	V <sub>DDPLL</sub> D
	H	B1	C3	unpopulated		F3	–	GND
A3	L	R4	C4	–	V <sub>DD</sub>	F4	–	GND
	H	B3	C5	–	GND	F5	–	GND
A4	L	R2	C6	–	V <sub>DD</sub>	F6	–	GND
	H	B5	C7	–	GND	F7	–	V <sub>DD</sub>
A5	L	R0	C8	L	B7	F8	L	B1
	H	B7		H	R0		H	R6
A6	L	G6	C9	L	B6	F9	L	B0
	H	G1		H	R1		H	R7
A7	L	G4	D1	–	NC	G1	–	D1–
	H	G3	D2	–	GND	G2	–	GND <sub>LVDS</sub>
A8	L	G2	D3	–	GND	G3	–	GND
	H	G5	D4	–	GND	G4	–	GND
A9	–	GND	D5	–	GND	G5	–	GND
B1	L	R7	D6	–	GND	G6	–	GND
	H	B0	D7	–	V <sub>DD</sub>	G7	–	V <sub>DD</sub>
B2	L	R5	D8	L	B5	G8	–	F/S
	H	B2		H	R2	G9	–	PCLK
B3	L	R3	D9	L	B4	H1	–	CPOL
	H	B4		H	R3	H2	–	V <sub>DDL</sub> VDS
B4	L	R1	E1	–	NC	H3	–	V <sub>DD</sub> PLLA
	H	B6	E2	–	GND <sub>PLL</sub> D	H4	–	GND <sub>PLLA</sub>
B5	L	G7	E3	–	GND	H5	–	V <sub>DDL</sub> VDS
	H	G0	E4	–	GND	H6	–	GND <sub>LVDS</sub>
B6	L	G5	E5	–	GND	H7	–	GND
	H	G2	E6	–	GND	H8	–	VS
B7	L	G3	E7	–	V <sub>DD</sub>	H9	–	HS
	H	G4	E8	L	B3	J1	–	GND <sub>LVDS</sub>
L	G1	H		R4	J2	–	SWAP	
B8	H	G6	E9	L	B2	J3	–	CLK+
	L	G0		H	R5	J4	–	CLK–
B9	L	G0				J5	–	D0+
	H	G7				J6	–	D0–
						J7	–	RXEN
						J8	–	DE
						J9	–	CPE

**Table 2. TERMINAL FUNCTIONS**

NAME	I/O	DESCRIPTION
D0+, D0–	SubLVDS in	SubLVDS data link (active during normal operation)
D1+, D1–		SubLVDS data link (active during normal operation when LS = high, high-impedance if LS = low); input can be left open if unused.
CLK+, CLK–		SubLVDS input pixel clock; polarity is fixed.
R0–R7	CMOS out	Red-pixel data (8); pin assignment depends on SWAP pin setting.
G0–G7		Green-pixel data (8); pin assignment depends on SWAP pin setting.
B0–B7		Blue-pixel data (8); pin assignment depends on SWAP pin setting.
HS		Horizontal sync
VS		Vertical sync
DE		Data enable
PCLK		Output pixel clock; rising or falling clock polarity is selected by control input CPOL.
LS		Link select (determines active SubLVDS data links and PLL range); see <a href="#">Table 3</a> .
RXEN		CMOS In
CPOL	Output clock polarity selection 0 – rising edge clocking 1 – falling edge clocking	
SWAP	Bus swap swaps the bus pins to allow device placement on top or bottom of PCB. See pinout drawing for pin assignments. 0 – data output from R7...B0 1 – data output from B0...R7	
F/S	CMOS bus rise time select 1 – fast-output rise time 0 – slow-output rise time	
CPE	CMOS out	Channel parity error This output indicates the detection of a parity error by generating an output high-pulse for half of a PCLK clock cycle; this allows counting parity errors with a simple counter. 0 – no error high-pulse – bit error detected
V <sub>DD</sub>	Power supply	Supply voltage
GND		Supply ground
V <sub>DDL</sub> VDS		SubLVDS I/O supply voltage
GND <sub>LVDS</sub>		SubLVDS ground
V <sub>DD</sub> PLLA		PLL analog supply voltage
GND <sub>PLLA</sub>		PLL analog GND
V <sub>DD</sub> PLLD		PLL digital supply voltage
GND <sub>PLLD</sub>		PLL digital GND

## FUNCTIONAL DESCRIPTION

### Deserialization Modes

The SN65LVDS304 receiver has two modes of operation controlled by link-select pin LS. Table 3 shows the deserializer modes of operation.

**Table 3. Logic Table: Link Select Operating Modes**

LS	MODE OF OPERATION		DATA LINKS STATUS
0	1ChM	1-channel mode (30-bit serialization rate)	D0 active
1	2ChM	2-channel mode (15-bit serialization rate)	D0, D1 active

#### 1-Channel Mode

While LS is held low, the SN65LVDS304 receives payload data over a single SubLVDS data pair, D0. The PLL locks to the SubLVDS clock input and internally multiplies the clock by a factor of 30. The internal high-speed clock is used to shift in the data payload on D0 and to deserialize 30 bits of data. Figure 3 illustrates the timing and the mapping of the data payload into the 30-bit frame. The internal high-speed clock is divided by a factor of 30 to recreate the pixel clock, and the data payload with the pixel clock is presented on the output bus. The reserved bits and parity bit are not output. While in this mode, the PLL can lock to a clock that is in the range of 4 MHz through 15 MHz. This mode is intended for smaller video display formats that do not need the full bandwidth capabilities of the SN65LVDS304.

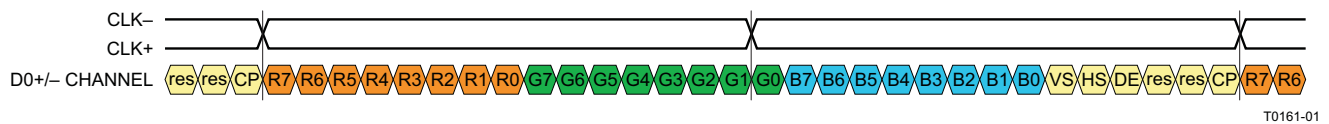

**Figure 3. Data and Clock Input in 1-ChM (LS = low)**

#### 2-Channel Mode

While LS is held high, the SN65LVDS304 receives payload data over two SubLVDS data pairs, D0 and D1. The PLL locks to the SubLVDS clock input and internally multiplies the clock by a factor of 15. The internal high-speed clock is used to shift in the data payload on D0 and D1 and to deserialize 15 bits of data from each pair. Figure 4 illustrates the timing and the mapping of the data payload into the 30-bit frame. The internal high-speed clock is divided by a factor of 15 to recreate the pixel clock, and the data payload with pixel clock is presented on the output bus. The reserved bits and parity bit are not output. While in this mode, the PLL can lock to a clock that is in the range of 8 MHz through 30 MHz.

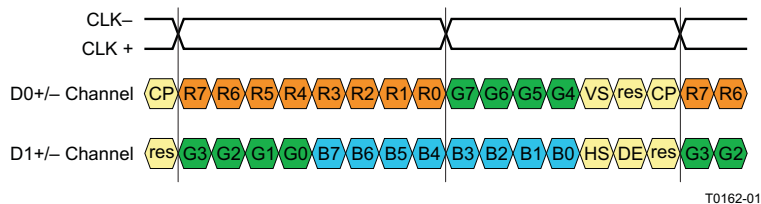

**Figure 4. Data and Clock Input in 2-ChM (LS = high)**

## POWER-DOWN MODES

The SN65LVDS304 receiver has two power-down modes to facilitate efficient power management.

### SHUTDOWN MODE

A low input signal on the RXEN pin puts the SN65LVDS304 into shutdown mode. This turns off most of the receiver circuitry including the SubLVDS receivers, PLL, and deserializers. The SubLVDS differential-input resistance remains 100 Ω, and any input signal is ignored. All outputs hold a static output pattern:

$$R[0:7] = G[0:7] = B[0:7] = VS = HS = \text{high}; DE = PCLK = \text{low}.$$

The current draw in shutdown mode is nearly zero if the SubLVDS inputs are left open or pulled high.

### STANDBY MODE

The SN65LVDS304 enters the standby mode when the SN65LVDS304 is not in shutdown mode but the SubLVDS clock-input common-mode voltage is above  $0.9 \times V_{DDLVDs}$ . The CLK input incorporates a pullup circuit to shift the SubLVDS clock-input common-mode voltage to  $V_{DDLVDs}$  in the absence of an input signal. All circuitry except the SubLVDS clock-input standby monitor is shut down. The SN65LVDS304 also enters the standby mode when the input clock frequency on the CLK input is less than 500 kHz. The SubLVDS input resistance remains 100  $\Omega$ , and any input signal on the data inputs D0 and D1 is ignored. All outputs will hold a static output pattern:

$R[0:7] = G[0:7] = B[0:7] = VS = HS = \text{high}; DE = PCLK = \text{low}.$

The current drawn in standby mode is very low.

### ACTIVE MODES

A high input signal on RXEN combined with a CLK input signal switching faster than 3 MHz and  $V_{ICM}$  smaller than 1.3 V forces the SN65LVDS304 into the active mode. Current consumption in the active mode depends on operating frequency and the number of data transitions in the data payload. CLK-input frequencies between 3 MHz and 4 MHz activate the device, but proper PLL functionality is not assured. It is not recommended to operate the SN65LVDS304 in active mode at CLK frequencies below 4 MHz.

#### ACQUIRE MODE (PLL Approaches Lock)

When the SN65LVDS304 is enabled and a SubLVDS clock input present, the PLL pursues lock to the input clock. While the PLL pursues lock, the output data bus holds a static output pattern:

$R[0:7] = G[0:7] = B[0:7] = VS = HS = \text{high}; DE = PCLK = \text{low}.$

For proper device operation, the pixel clock frequency must fall within the valid  $f_{PCLK}$  range specified under recommended operating conditions. If the pixel clock frequency is larger than 3 MHz but smaller than  $f_{PCLK(\text{min})}$ , the SN65LVDS304 PLL is enabled. Under such conditions, it is possible for the PLL to lock temporarily to the pixel clock, causing the PLL monitor to release the device into active receive mode. If this happens, the PLL may or may not be properly locked to the pixel clock input, potentially causing data errors, frequency oscillation, and PLL deadlock (loss of VCO oscillation).

### RECEIVE MODE

After the PLL achieves lock the device enters the normal receive mode. The output data bus presents the deserialized data. The PCLK output pin outputs the recovered pixel clock.

#### PARITY ERROR DETECTION AND HANDLING

The SN65LVDS304 receiver performs error checking on the basis of a parity bit that is transmitted across the SubLVDS interface from the transmitting device. Once the SN65LVDS304 detects the presence of the clock and the PLL has locked onto PCLK, then the parity is checked. Parity-error detection ensures detection of all single-bit errors in one pixel and 50% of all multibit errors.

The parity bit covers the 27-bit data payload consisting of 24 bits of pixel data plus VS, HS, and DE. Odd-parity bit signalling is used. The parity error is output on the CPE pin. If the sum of the 27 data bits and the parity bit result in an odd number, the receive data are assumed to be valid. The CPE output is held low. If the sum equals an even number, parity error is declared. The CPE output indicates high for half a PCLK period. The CPE output is set with the data bit transition and cleared after 1/2 the data-bit time. This allows counting every detected parity error with a simple counter connected to CPE.

If a parity error is detected, then the data on that PCLK cycle is not output. Instead, the last valid data from a previous PCLK cycle is repeated on the output bus. This is to prevent any bit error that occurs on the LVDS link from causing perturbations in VS, HS, or DE that might be visually disruptive to a display.

The reserved bits are not covered in the parity calculations.

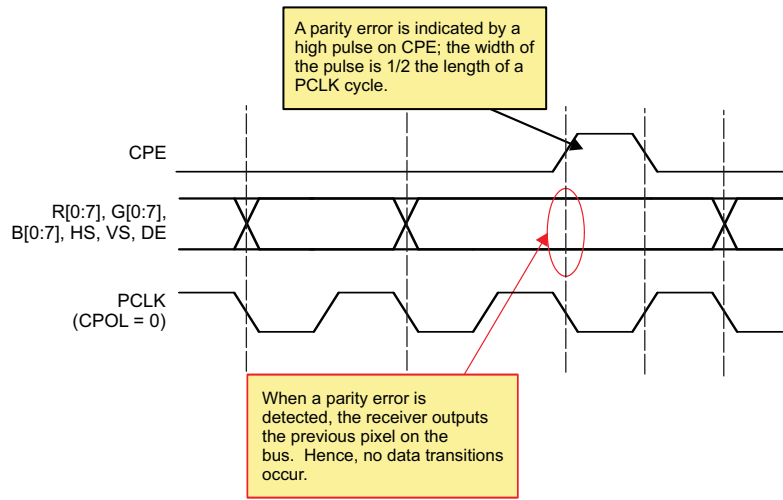

T0163-01

Figure 5. Parity Error Detection

STATUS-DETECT AND OPERATING-MODES FLOW DIAGRAM

The SN65LVDS304 switches between the power saving and active modes in the following way:

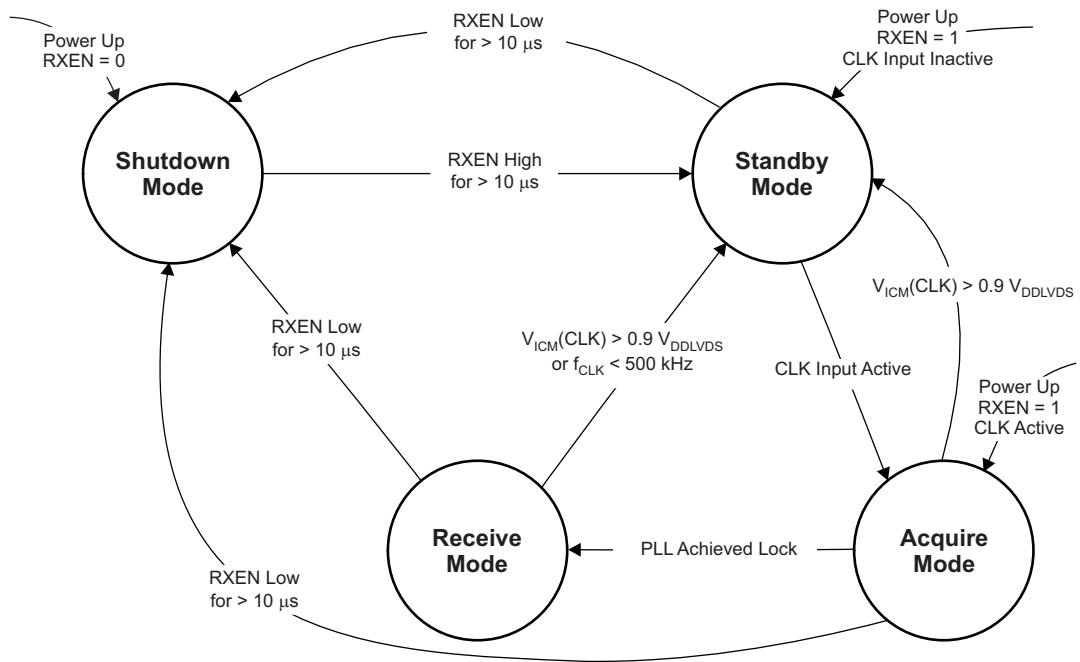

F0017-01

**Table 4. Status Detect and Operating Modes Descriptions**

MODE	CHARACTERISTICS	CONDITIONS
Shutdown mode	Least amount of power consumption (most circuitry turned off); all outputs held static: R[0:7] = G[0:7] = B[0:7] = VS = HS = high; DE = PCLK = low	RXEN is set low for longer than 10 $\mu$ s. <sup>(1)(2)</sup>
Standby mode	Low power consumption (standby monitor circuit active; PLL is shutdown to conserve power); All outputs held static: R[0:7] = G[0:7] = B[0:7] = VS = HS = high; DE = PCLK = low	RXEN is high for longer than 10 $\mu$ s and CLK inputs are common-mode, $V_{ICM(CLK)}$ is above $0.9 \times V_{DDLVDs}$ , or CLK inputs are floating <sup>(2)</sup>
Acquire mode	PLL pursues lock; all outputs held static: R[0:7] = G[0:7] = B[0:7] = VS = HS = high; DE = PCLK = low	RXEN is high; CLK input monitor detected clock input common mode and woke up receiver from standby mode.
Receive mode	Data transfer (normal operation); receiver deserializes data and provides data on parallel output	RXEN is high and PLL is locked to incoming clock.

(1) In shutdown mode, all SN65LVDS304 internal switching circuits (e.g., PLL, serializer, etc.) are turned off to minimize power consumption. The input stage of any input pin remains active.

(2) Leaving CMOS control inputs unconnected can cause random noise to toggle the input stage and potentially harm the device. All CMOS inputs must be tied to a valid logic level,  $V_{IL}$  or  $V_{IH}$ , during shutdown or standby Mode. Exceptions are the SubLVDS inputs CLK and Dx, which can be left unconnected while not in use.

**Table 5. Operating Mode Transitions**

MODE TRANSITION	USE CASE	TRANSITION SPECIFICS
Shutdown $\rightarrow$ standby	Drive RXEN high to enable receiver.	<ol style="list-style-type: none"> <li>1. RXEN high &gt; 10 <math>\mu</math>s</li> <li>2. Receiver enters standby mode. <ol style="list-style-type: none"> <li>a. R[0:7] = G[0:7] = B[0:7] = VS = HS remain high and DE = PCLK low</li> <li>b. Receiver activates clock input monitor.</li> </ol> </li> </ol>
Standby $\rightarrow$ acquire	Transmitter activity detected	<ol style="list-style-type: none"> <li>1. CLK input monitor detects clock input activity.</li> <li>2. Outputs remain static.</li> <li>3. PLL circuit is enabled.</li> </ol>
Acquire $\rightarrow$ receive	Link is ready to receive data.	<ol style="list-style-type: none"> <li>1. PLL is active and approaches lock.</li> <li>2. PLL achieves lock within <math>t_{wakeup}</math>.</li> <li>3. Input D0 or D1 becomes active, depending on LS selection.</li> <li>4. First data word is recovered.</li> <li>5. Parallel output bus turns on switching from a static output pattern to output the first valid data word.</li> </ol>
Receive $\rightarrow$ standby	Transmitter requested to enter standby mode by input common mode voltage $V_{ICM} > 0.9 V_{DDLVDs}$ (e.g., transmitter output clock stops or enters high-impedance state)	<ol style="list-style-type: none"> <li>1. Receiver disables outputs within <math>t_{sleep}</math>.</li> <li>2. RX Input monitor detects <math>V_{ICM} &gt; 0.9 V_{DDLVDs}</math> within <math>t_{sleep}</math>.</li> <li>3. R[0:7] = G[0:7] = B[0:7] = VS = HS transition to high and DE = PCLK to low on next falling PLL clock edge</li> <li>4. PLL shuts down. Clock activity input monitor remains active.</li> </ol>
Receive/standby $\rightarrow$ shutdown	Turn off receiver.	<ol style="list-style-type: none"> <li>1. RXEN pulled low for &gt; <math>t_{pwrdn}</math>.</li> <li>2. R[0:7] = G[0:7] = B[0:7] = VS = HS remain static high or transition to static high and DE = PCLK remain or transition to static low.</li> <li>3. Most IC circuitry is shut down for least power consumption.</li> </ol>

**ABSOLUTE MAXIMUM RATINGS<sup>(1)</sup>**

		VALUE	UNIT
Supply voltage range, $V_{DD}^{(2)}$ , $V_{DDPLLA}$ , $V_{DDPLLD}$ , $V_{DDLVDs}$		-0.3 to 2.175	V
Voltage range at any input or output terminal	When $V_{DDx} > 0$ V	-0.5 to 2.175	V
	When $V_{DDx} \leq 0$ V	-0.5 to $V_{DD} + 2.175$	
Electrostatic discharge	Human body model <sup>(3)</sup> (all pins)	$\pm 4$	kV
	Charged-device model <sup>(4)</sup> (all pins)	$\pm 1500$	V
	Machine model <sup>(5)</sup> (all pins)	$\pm 200$	
Continuous power dissipation		See Dissipation Ratings Table	
Output current, $I_O$		$\pm 5$	mA

- (1) Stresses beyond those listed under *absolute maximum ratings* may cause permanent damage to the device. These are stress ratings only and functional operation of the device at these or any other conditions beyond those indicated under *recommended operating conditions* is not implied. Exposure to absolute maximum-rated conditions for extended periods may affect device reliability.
- (2) All voltage values are with respect to the GND terminals.
- (3) In accordance with JEDEC Standard 22, Test Method A114-B
- (4) In accordance with JEDEC Standard 22, Test Method C101
- (5) In accordance with JEDEC Standard 22, Test Method A115-A

**DISSIPATION RATINGS**

PACKAGE	CIRCUIT BOARD MODEL	$T_A < 25^\circ\text{C}$	DERATING FACTOR <sup>(1)</sup> ABOVE $T_A = 25^\circ\text{C}$	$T_A = 85^\circ\text{C}$ POWER RATING
ZQE	Low-K <sup>(2)</sup>	592 mW	7.407 mW/°C	148 mW

- (1) This is the inverse of the junction-to-ambient thermal resistance when board-mounted and with no air flow.
- (2) In accordance with the low-K thermal metric definitions of EIA/JESD51-2.

**DEVICE POWER DISSIPATION**

PARAMETER	TEST CONDITIONS	TYP	MAX	UNIT
$P_D$ Device power dissipation	$V_{DDx} = 1.8$ V, $T_A = 25^\circ\text{C}$ , all outputs terminated with 10 pF, $f_{CLK}$ at 4 MHz	16.8		mW
	$V_{DDx} = 1.95$ V, $T_A = -40^\circ\text{C}$ , all outputs terminated with 10 pF, $f_{CLK}$ at 30 MHz		72.2	

**RECOMMENDED OPERATING CONDITIONS<sup>(1)</sup>**

			MIN	TYP	MAX	UNIT
$V_{DD}$ $V_{DDPLLA}$ $V_{DDPLLD}$ $V_{DDLVDs}$	Supply voltages		1.65	1.8	1.95	V
$V_{DDn(PP)}$	Supply voltage noise magnitude	Test set-up shown in <a href="#">Figure 7</a> ; $f_{CLK} \leq 50\text{MHz}$ ; $f(\text{noise}) = 1\text{Hz to } 2\text{GHz}$			100	mV
		$f_{CLK} > 50\text{MHz}$ ; $f(\text{noise}) = 1\text{Hz to } 1\text{MHz}$			100	
		$f_{CLK} > 50\text{MHz}$ ; $f(\text{noise}) > 1\text{MHz}$			40	
$T_A$	Operating free-air temperature		-40		85	°C
<b>CLK+ and CLK-</b>						
$f_{CLK\pm}$	Input pixel clock frequency	1-channel transmit mode, see <a href="#">Figure 3</a>	4		15	MHz
		2-channel transmit mode, see <a href="#">Figure 4</a>	8		30	
		Standby mode <sup>(2)</sup> , see <a href="#">Figure 16</a>			500	kHz
$t_{DUTCLK}$	CLK input duty cycle		35		65	%
<b>D0+, D0-, D1+, D1-, CLK+, and CLK-</b>						
$ V_{ID} $	Magnitude of differential input voltage	$ V_{D0+} - V_{D0-} $ , $ V_{D1+} - V_{D1-} $ , $ V_{CLK+} - V_{CLK-} $ during normal operation	70		200	mV
$V_{ICM}$	Input voltage common mode range	Receive or acquire mode	0.6		1.2	V
		Standby mode	0.9 $V_{DDLVDs}$			
$\Delta V_{ICM}$	Input voltage common mode variation among all SubLVDS inputs	$V_{ICM(n)} - V_{ICM(m)}$ with $n = D0, D1$ , or CLK and $m = D0, D1$ , or CLK	-100		100	mV
$\Delta V_{ID}$	Differential input voltage amplitude variation among all SubLVDS inputs	$V_{ID(n)} - V_{ID(m)}$ with $n = D0, D1$ , or CLK and $m = D0, D1$ , or CLK	-10		10	%
$t_{r/f}$	Input rise and fall times	RXEN at $V_{DD}$ ; see <a href="#">Figure 10</a>			800	ps
$\Delta t_{r/f}$	Input rise or fall time mismatch among all SubLVDS inputs	$t_{r(n)} - t_{r(m)}$ and $t_{f(n)} - t_{f(m)}$ with $n = D0, D1$ , or CLK and $m = D0, D1$ , or CLK	-100		100	ps
<b>LS, CPOL, SWAP, RXEN, F/S</b>						
$V_{ICMOSH}$	High-level input voltage		0.7 $V_{DD}$		$V_{DD}$	V
$V_{ICMOSL}$	Low-level input voltage		0		0.3 $V_{DD}$	V
$t_{inRXEN}$	RXEN input pulse duration		10			µs
<b>R[7:0], G[7:0], B[7:0], VS, HS, PCLK, CPE</b>						
$C_L$	Output load capacitance			10		pF

(1) Unused single-ended inputs must be held high or low to prevent them from floating.

(2) PCLK input frequencies lower than 500 kHz force the SN65LVDS304 into standby mode. Input frequencies between 500 kHz and 3 MHz may or may not activate the SN65LVDS304. Input frequencies beyond 3 MHz activate the SN65LVDS304. Input frequencies between 500 kHz and 4 MHz are not recommended, and can cause PLL malfunction.

**DEVICE ELECTRICAL CHARACTERISTICS**

over recommended operating conditions (unless otherwise noted)

PARAMETER	TEST CONDITIONS		MIN	TYP <sup>(1)</sup>	MAX	UNIT
I <sub>DD</sub> RMS supply current	1ChM	Alternating 1010 test pattern (see Table 9); all CMOS outputs terminated with 10 pF; F/S and RXEN at V <sub>DD</sub> ; V <sub>IH</sub> = V <sub>DD</sub> , V <sub>IL</sub> = 0 V; V <sub>DD</sub> = V <sub>DDPLL</sub> = V <sub>DDPLL</sub> = V <sub>DDLVD</sub>	f <sub>PCLK</sub> = 4 MHz	9.8	14	mA
			f <sub>PCLK</sub> = 6 MHz	11.7	15.9	
			f <sub>PCLK</sub> = 15 MHz	19.3	25	
	1ChM	Typical power test pattern (see Table 7); V <sub>ID</sub> = 70 mV, all CMOS outputs terminated with 10 pF; F/S at GND and RXEN at V <sub>DD</sub> ; V <sub>IH</sub> = V <sub>DD</sub> , V <sub>IL</sub> = 0 V; V <sub>DD</sub> = V <sub>DDPLL</sub> = V <sub>DDPLL</sub> = V <sub>DDLVD</sub>	f <sub>PCLK</sub> = 4 MHz	4.7		mA
			f <sub>PCLK</sub> = 6 MHz	6		
			f <sub>PCLK</sub> = 15 MHz	13.2		
	2ChM	Alternating 1010 test pattern (see Table 9); all CMOS outputs terminated with 10 pF; F/S and RXEN at V <sub>DD</sub> ; V <sub>IH</sub> = V <sub>DD</sub> , V <sub>IL</sub> = 0 V; V <sub>DD</sub> = V <sub>DDPLL</sub> = V <sub>DDPLL</sub> = V <sub>DDLVD</sub>	f <sub>PCLK</sub> = 8 MHz	14.3	19.4	mA
			f <sub>PCLK</sub> = 22 MHz	25	33	
			f <sub>PCLK</sub> = 30 MHz	26.8	37	
		2ChM	Typical power test pattern (see Table 8); V <sub>ID</sub> = 70 mV, all CMOS outputs terminated with 10 pF; F/S at GND and RXEN at V <sub>DD</sub> ; V <sub>IH</sub> = V <sub>DD</sub> , V <sub>IL</sub> = 0 V; V <sub>DD</sub> = V <sub>DDPLL</sub> = V <sub>DDPLL</sub> = V <sub>DDLVD</sub>	f <sub>PCLK</sub> = 8 MHz	6.4	
f <sub>PCLK</sub> = 22 MHz				13.7		
f <sub>PCLK</sub> = 30 MHz				18.3		
CLK and D inputs are left open; all control inputs held static high or low; All CMOS outputs terminated with 10 pF; V <sub>IH</sub> = V <sub>DD</sub> , V <sub>IL</sub> = 0 V; V <sub>DD</sub> = V <sub>DDPLL</sub> = V <sub>DDPLL</sub> = V <sub>DDLVD</sub>	Standby mode; RXEN = V <sub>IH</sub>	15	100	μA		
	Shutdown mode; RXEN = V <sub>IL</sub>	0.4	10			

(1) All typical values are at 25°C and with 1.8-V supply, unless otherwise noted.

## INPUT ELECTRICAL CHARACTERISTICS

over operating free-air temperature range (unless otherwise noted)

PARAMETER		TEST CONDITIONS	MIN	TYP <sup>(1)</sup>	MAX	UNIT
<b>D0+, D0-, D1+, D1-, CLK+, and CLK-</b>						
$V_{thstby}$	Input voltage common mode threshold to switch between receive/acquire mode and standby mode	RXEN at $V_{DD}$	1.3		$0.9 V_{DDLVDs}$	V
$V_{THL}$	Low-level differential input voltage threshold	$V_{D0+} - V_{D0-}$ , $V_{D1+} - V_{D1-}$ , $V_{CLK+} - V_{CLK-}$	-40			mV
$V_{THH}$	High-level differential input voltage threshold				40	mV
$I_{I+}$ , $I_{I-}$	Input leakage current	$V_{DD} = 1.95$ V; $V_{I+} = V_{I-}$ ; $V_I = 0.4$ V and $V_I = 1.5$ V			75	$\mu$ A
$I_{IOFF}$	Power-off input current	$V_{DD} = GND$ ; $V_I = 1.5$ V			-75	$\mu$ A
$R_{ID}$	Differential input termination resistor value		78	100	122	$\Omega$
$C_{IN}$	Input capacitance	Measured between input terminal and GND		1		pF
$\Delta C_{IN}$	Input capacitance variation	Within one signal pair Between all signals			0.2 1	pF
$R_{BBDC}$	Pullup resistor for standby detection		21	30	39	k $\Omega$
<b>LS, CPOL, SWAP, RXEN, F/S</b>						
$V_{IK}$	Input clamp voltage	$I_I = -18$ mA, $V_{DD} = V_{DD}(\min)$			-1.2	V
$I_{CMOS}$	Input current <sup>(2)</sup>	$0$ V $\leq V_{DD} \leq 1.95$ V; $V_I = GND$ or $V_I = 1.95$ V			100	nA
$C_{IN}$	Input capacitance			2		pF
$I_{IH}$	High-level input current	$V_{IN} = 0.7 V_{DD}$	-200		200	nA
$I_{IL}$	Low-level input current	$V_{IN} = 0.3 V_{DD}$	-200		200	nA
$V_{IH}$	High-level input voltage		$0.7 V_{DD}$		$V_{DD}$	V
$V_{IL}$	Low-level input voltage		0		$0.3 V_{DD}$	V

(1) All typical values are at 25°C and with 1.8-V supply unless otherwise noted.

(2) Do not leave any CMOS input unconnected or floating to minimize leakage currents. Every input must be connected to a valid logic level,  $V_{IH}$  or  $V_{OL}$ , while power is supplied to  $V_{DD}$ .

## OUTPUT ELECTRICAL CHARACTERISTICS

over operating free-air temperature range (unless otherwise noted)

PARAMETER		TEST CONDITIONS	MIN	TYP	MAX	UNIT
<b>R[0:7], G[0:7], B[0:7], VS, HS, PCLK, CPE</b>						
$V_{OH}$	High-level output current	1-ChM, F/S = L, $I_{OH} = -250$ $\mu$ A	$0.8 V_{DD}$		$V_{DD}$	V
		2-ChM, F/S = L, $I_{OH} = -500$ $\mu$ A				
		1-ChM, F/S = H, $I_{OH} = -500$ $\mu$ A				
		2-ChM, F/S = H, $I_{OH} = -2$ mA				
$V_{OL}$	Low-level output current	1-ChM, F/S = L, $I_{OL} = 250$ $\mu$ A	0		$0.2 V_{DD}$	V
		2-ChM, F/S = L, $I_{OL} = 500$ $\mu$ A				
		1-ChM, F/S = H, $I_{OL} = 500$ $\mu$ A				
		2-ChM, F/S = H, $I_{OL} = 2$ mA				
$I_{OH}$	High-level output current	1-ChM, F/S = L				$\mu$ A
		2-ChM, F/S = L; 1-ChM, F/S = H				
		2-ChM, F/S = H				
$I_{OL}$	Low-level output current	1-ChM, F/S = L				$\mu$ A
		2-ChM, F/S = L; 1-ChM, F/S = H				
		2-ChM, F/S = H				

## SWITCHING CHARACTERISTICS

over recommended operating conditions (unless otherwise noted)

PARAMETER	TEST CONDITIONS	MIN	TYP <sup>(1)</sup>	MAX	UNIT			
<b>D0+, D0–, D1+, D1–, CLK+, and CLK–</b>								
$t_{r/f}$	Input rise and fall times	RXEN at $V_{DD}$ ; see Figure 10			800	ps		
$\Delta t_{r/f}$	Input rise or fall time mismatch between all SubLVDS inputs	$t_{R(n)} - t_{R(m)}$ and $t_{F(n)} - t_{F(m)}$ with $n = D0, D1$ or CLK and $m = D0, D1$ , or CLK			–100	100	ps	
<b>R[7:0], G[7:0], B[7:0], VS, HS, PCLK, CPE</b>								
$t_{r/f}$	Rise and fall time 20% $\leftrightarrow$ 80% of $V_{DD}$ <sup>(2)</sup>	$C_L = 10$ pF <sup>(3)</sup> ; see Figure 9	1-channel mode, F/S = L	8	16	ns		
			2-channel mode, F/S = L	4	8			
			1-channel mode, F/S = H	4	8			
			2-channel mode, F/S = H	1	2			
$t_{OUTP}$	PCLK output duty cycle	1-channel mode	45%	50%	55%			
		CPOL = $V_{IL}$ , 2-channel mode	48%	53%	59%			
		CPOL = $V_{IH}$ , 2-channel mode	41%	47%	52%			
$t_{OSK}$	Output skew between PCLK and R[0:7], G[0:7], B[0:7], HS, VS, and DE	See Figure 9.			–500	500	ps	
<b>INPUT TO OUTPUT RESPONSE TIME</b>								
$t_{PD(L)}$	Propagation delay time from CLK+ input to PCLK output	RXEN at $V_{DD}$ , $V_{IH} = V_{DD}$ , $V_{IL} = GND$ , $C_L = 10$ pF, See Figure 14			$1.4/f_{PCLK}$	$1.9/f_{PCLK}$	$2.5/f_{PCLK}$	s
$t_{GS}$	RXEN glitch suppression pulse width <sup>(4)</sup>	$V_{IH} = V_{DD}$ , $V_{IL} = GND$ , RXEN toggles between $V_{IL}$ and $V_{IH}$ ; see Figure 15 and Figure 16.			3.8			$\mu$ s
$t_{pwrap}$	Enable time from power down ( $\uparrow$ RXEN)	Time from RXEN pulled high to data outputs enabled and transmit valid data; see Figure 16.			2			ms
$t_{pwrdn}$	Disable time from active mode ( $\downarrow$ RXEN)	RXEN is pulled low during receive mode; time measurement until all outputs held static: R[0:7] = G[0:7] = B[0:7] = VS = HS = high, DE = PCLK = low and PLL is shut down; see Figure 16.			11			$\mu$ s
$t_{wakeup}$	Enable time from standby ( $\uparrow$ CLK)	RXEN at $V_{DD}$ ; device is in standby; time measurement from CLK input starts switching to PCLK and data outputs enabled and transmit valid data; see Figure 17.			2			ms
$t_{sleep}$	Disable time from active mode (CLK transitions to high-impedance)	RXEN at $V_{DD}$ ; device is receiving data; time measurement from CLK input signal stops (input open or input common mode $V_{ICM}$ exceeds threshold voltage $V_{thslby}$ ) until all outputs held static: R[0:7] = G[0:7] = B[0:7] = VS = HS = high; DE = PCLK = low and PLL is shut down; see Figure 17.			3			$\mu$ s
$f_{BW}$	PLL bandwidth <sup>(5)</sup>	Tested from CLK input to PCLK output; 2-ChM; $f_{PCLK} = 22$ MHz			$0.087 f_{PCLK}$			MHz

- (1) All typical values are at 25°C and with 1.8-V supply, unless otherwise noted.
- (2)  $t_{R/F}$  depends on the F/S setting and the capacitive load connected to each output. Some application information of how to calculate  $t_{R/F}$  based on the output load and how to estimate the timing budget to interconnect to an LCD driver are provided in the application section near the end of this data sheet.
- (3) The output rise and fall times are optimized for an output load of 10 pF. The rise and fall times can be adjusted by changing the output load capacitance.
- (4) The RXEN input incorporates glitch-suppression logic to disregard short input pulses.  $t_{GS}$  is the duration of either a high-to-low or low-to-high transition that is suppressed.
- (5) When using the SN65LVDS304 receiver in conjunction with the SN65LVDS303 transmitter in one link, the PLL bandwidth of the SN65LVDS304 receiver always exceeds the bandwidth of the SN65LVDS303 transmit PLL. This ensures stable PLL tracking under all operating conditions and maximizes the receiver skew margin.

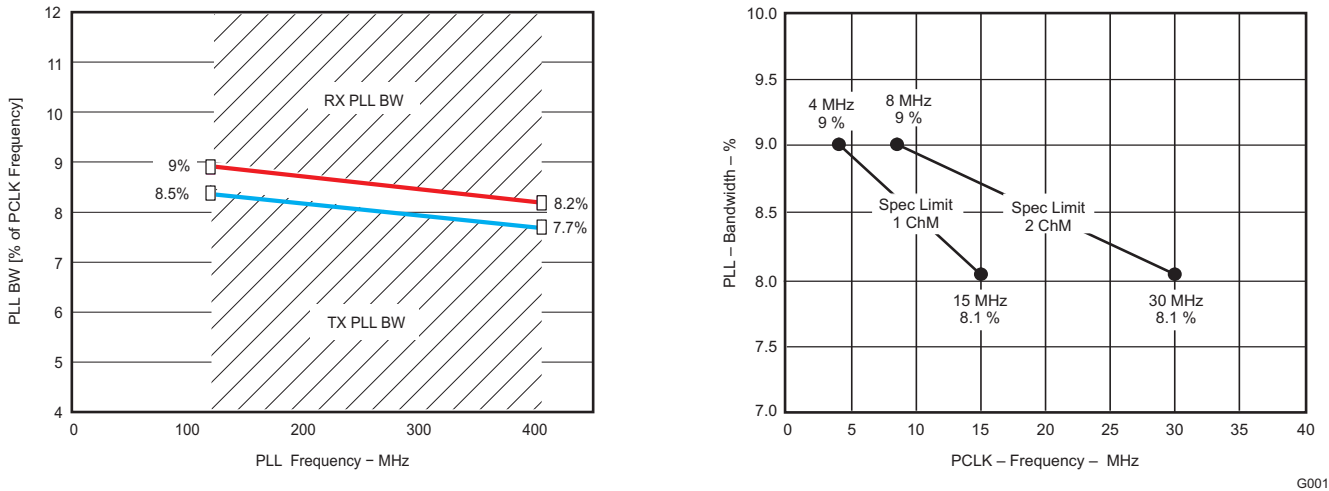

Figure 6. SN65LVDS304 PLL Bandwidth (Also Showing the SN65LVDS303 PLL Bandwidth)

G001

**TIMING CHARACTERISTICS**

PARAMETER	TEST CONDITIONS	MIN	MAX	UNIT
$t_{RSKMx}$ (1)(2) Receiver input skew margin; see (3) and Figure 36	1ChM: $x = 0..29$ , $f_{PCLK} = 15$ MHz; RXEN at $V_{DD}$ , $V_{IH} = V_{DD}$ , $V_{IL} = GND$ , $R_L = 100 \Omega$ , test setup as in Figure 8, test pattern as in Table 11	$f_{CLK} = 15$ MHz <sup>(4)</sup>	630	ps
		$f_{CLK} = 4$ MHz to 15 MHz <sup>(5)</sup>	$\frac{1}{2 \cdot 30 \cdot f_{CLK}} - 480$ ps	
	2ChM: $x = 0..14$ , $f_{PCLK} = 30$ MHz; RXEN at $V_{DD}$ , $V_{IH} = V_{DD}$ , $V_{IL} = GND$ , $R_L = 100 \Omega$ , test setup as in Figure 8, test pattern as in Table 12	$f_{CLK} = 30$ MHz <sup>(4)</sup>	630	
		$f_{CLK} = 8$ MHz to 30 MHz <sup>(5)</sup>	$\frac{1}{2 \cdot 15 \cdot f_{CLK}} - 480$ ps	

- (1) Receiver input skew margin ( $t_{RSKM}$ ) is the timing margin available for transmitter output pulse position ( $t_{PPoS}$ ), interconnect skew, and interconnect inter-symbol interference.  $t_{RSKM}$  represents the remainder of the serial bit time not taken up by the receiver strobe uncertainty.  $t_{RSKM}$  assumes a bit error rate better than  $10^{-12}$ .
- (2)  $t_{RSKM}$  is inversely proportional to the internal setup and hold time uncertainty, ISI and duty cycle distortion from the front end receiver, the skew mismatch between CLK and data D0 and D1, as well as the PLL cycle-to-cycle jitter.
- (3) This includes the receiver internal setup and hold time uncertainty, all PLL related high-frequency random and deterministic jitter components that impact the jitter budget, ISI and duty cycle distortion from the front-end receiver, and the skew between CLK and data D0 and D1; the pulse position minimum/maximum variation is given with a bit error rate target of  $10^{-12}$ ; measurements of the total jitter are taken over  $>10^{-12}$  samples.
- (4) The minimum and maximum limits are based on statistical analysis of the device performance over process, voltage, and temperature ranges.
- (5) These minimum and maximum limits are simulated only.

PARAMETER MEASUREMENT INFORMATION

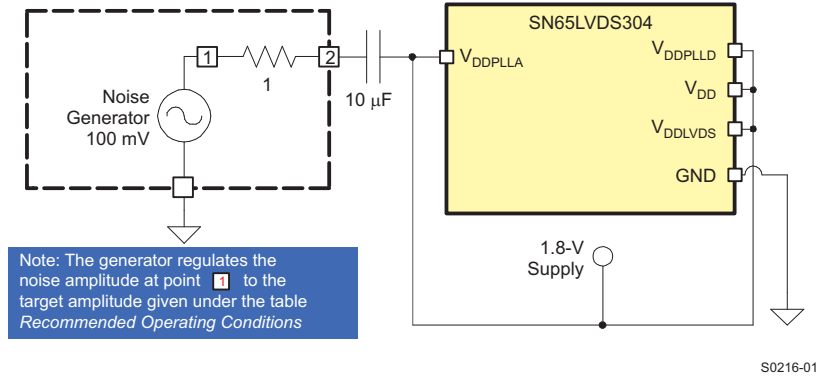

Figure 7. Power-Supply Noise Test Setup

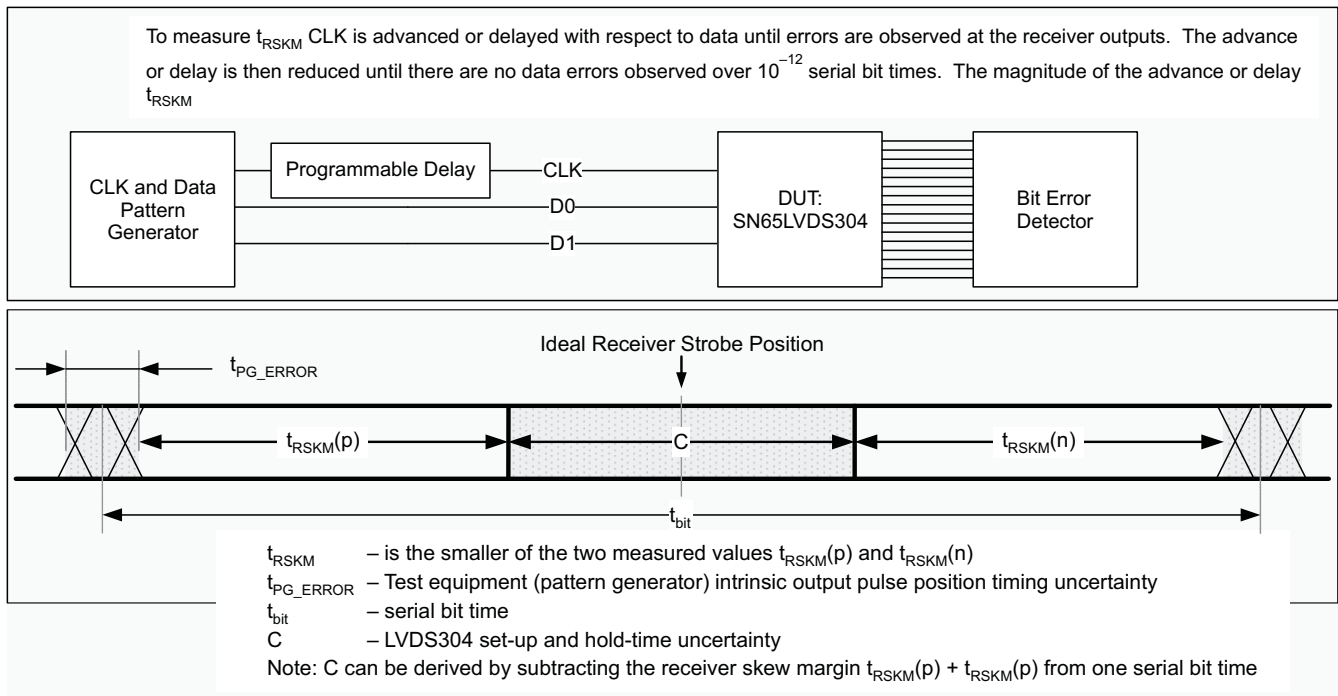

Figure 8. Receiver Jitter-Budget Test Setup

PARAMETER MEASUREMENT INFORMATION (continued)

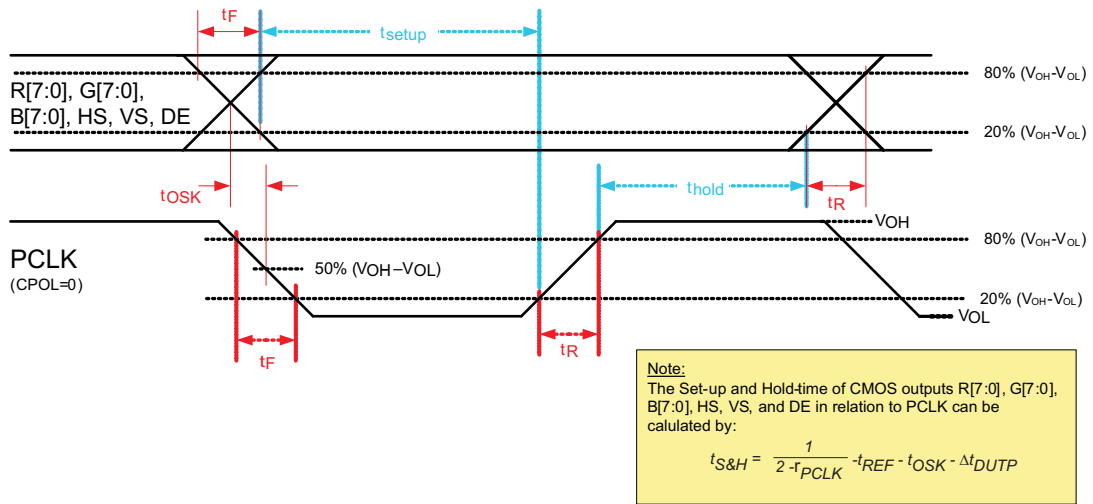

Figure 9. Output Rise/Fall, Setup/Hold Time

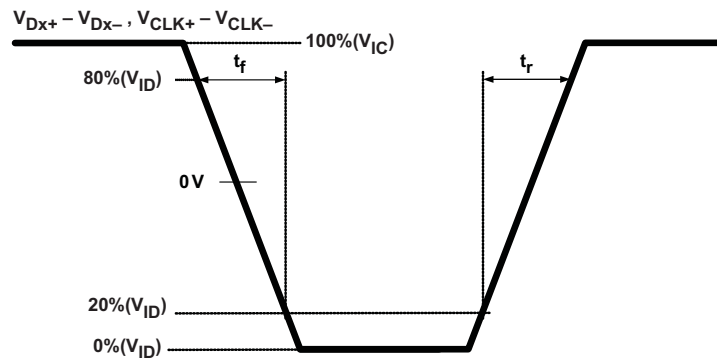
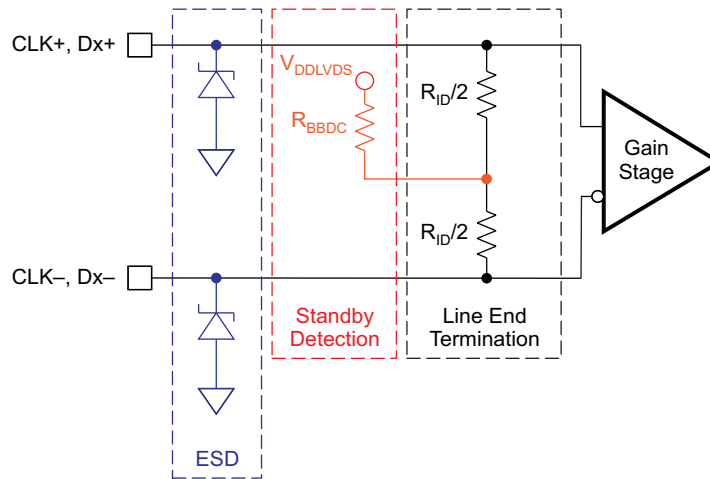

Figure 10. SubLVDS Differential Input Rise and Fall Time Definition



S0224-02

Figure 11. Equivalent Input Circuit Design

PARAMETER MEASUREMENT INFORMATION (continued)

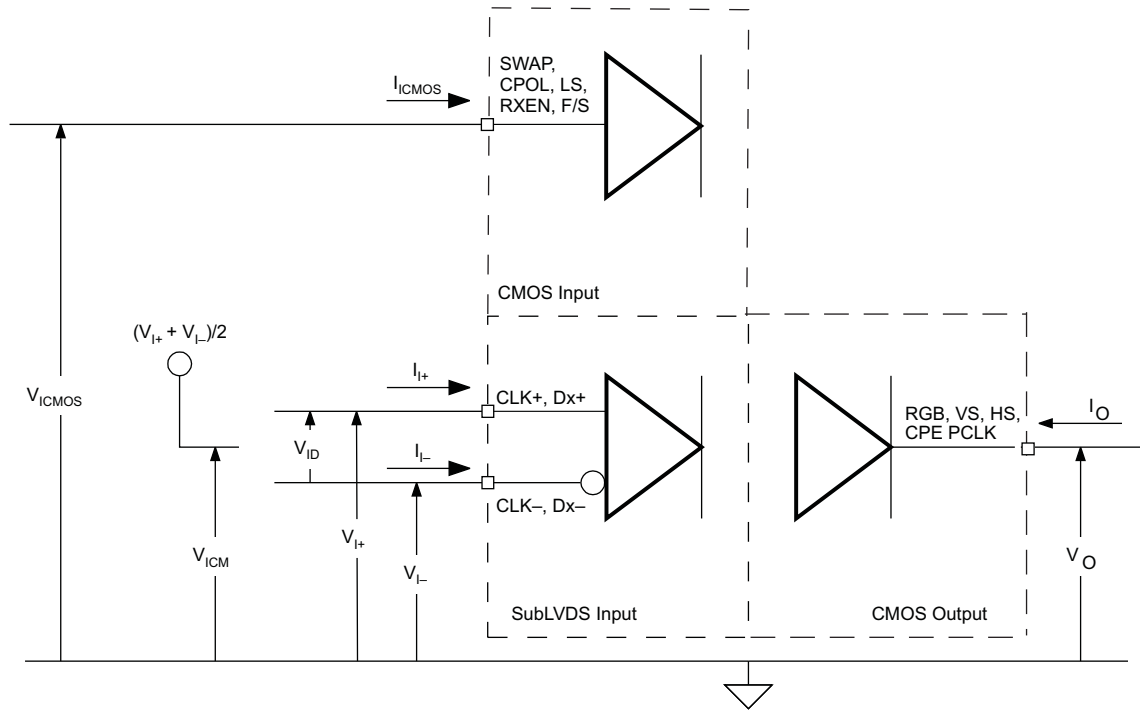

S0217-01

Figure 12. I/O Voltage and Current Definition

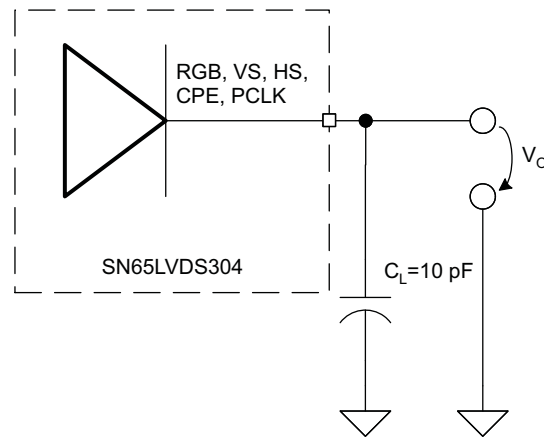

S0218-01

Figure 13. CMOS Output Test Circuit, Signal, and Timing Definition

PARAMETER MEASUREMENT INFORMATION (continued)

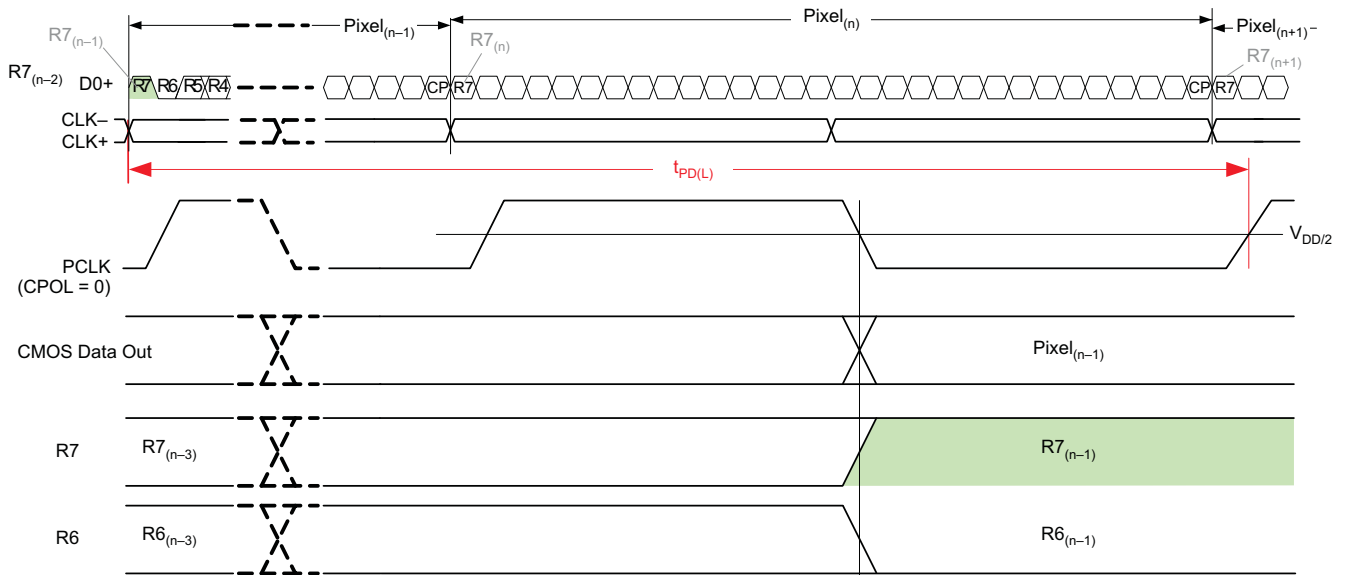

Figure 14. Propagation Delay, Input to Output (LS = 0)

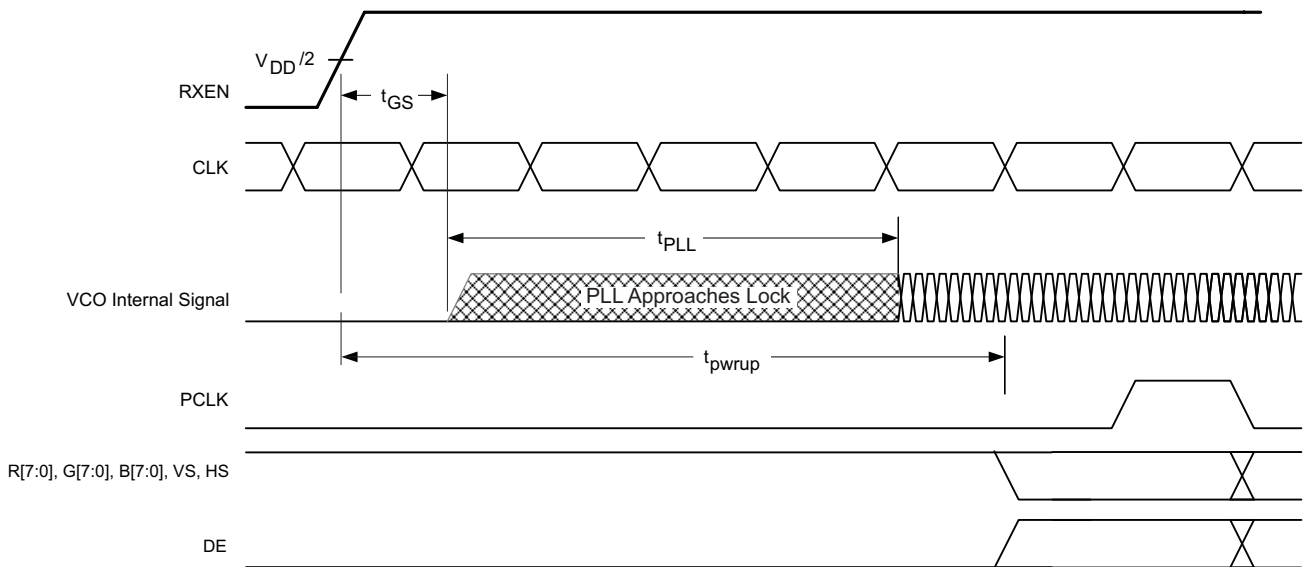

Figure 15. Receiver Phase-Locked Loop Set Time and Receiver Enable Time

PARAMETER MEASUREMENT INFORMATION (continued)

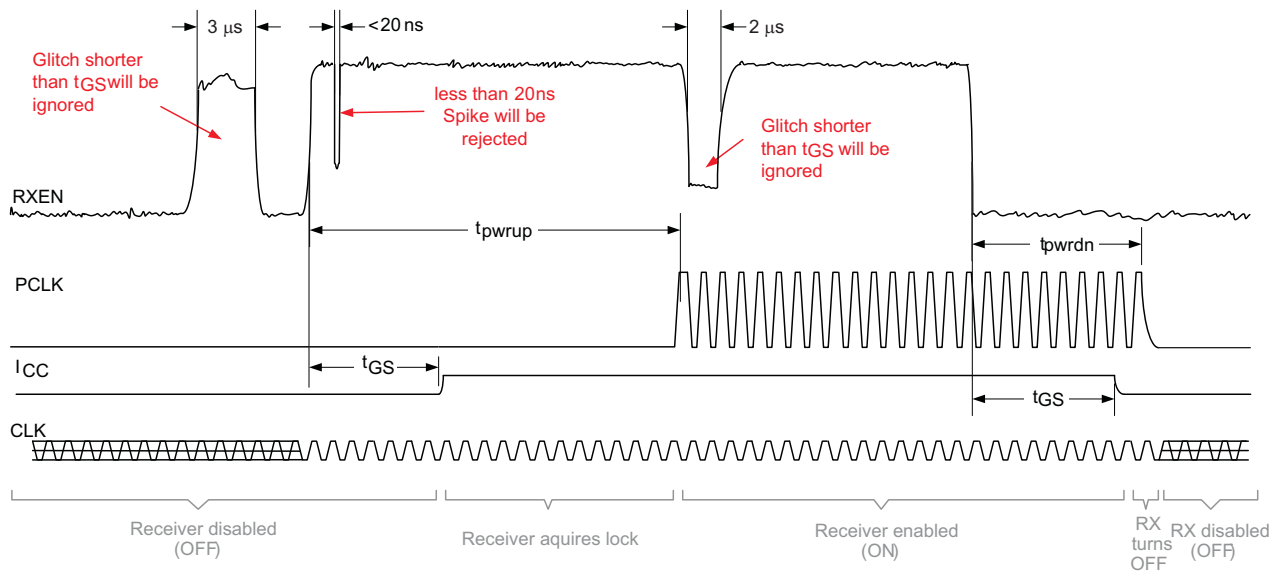

Figure 16. Receiver Enable/Disable Glitch Suppression Time

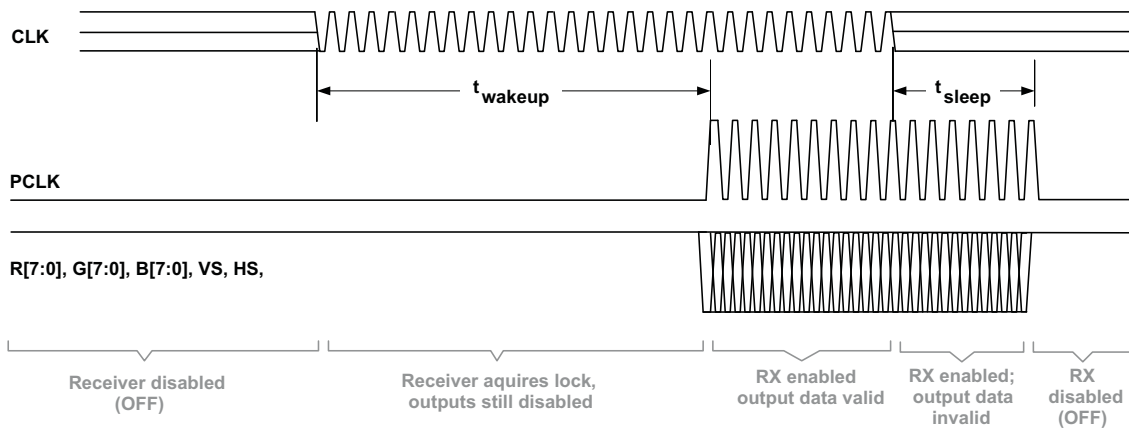

Figure 17. Standby Detection

POWER CONSUMPTION TESTS

Table 6 shows an example test pattern word.

Table 6. Example Test Pattern Word

WORD	R[7:4], R[3:0], G[7:4], G[3:0], B[7:4], B[3:0], 0, VS, HS, DE
1	0x7C3E1E7

7				C				3				E				1				E				7			
R7	R6	R5	R4	R3	R2	R1	R0	G7	G6	G5	G4	G3	G2	G1	G0	B7	B6	B5	B4	B3	B2	B1	B0	0	VS	HS	DE
0	1	1	1	1	1	0	0	0	0	1	1	1	1	1	0	0	0	0	1	1	1	1	0	0	1	1	1

## TYPICAL IC POWER-CONSUMPTION TEST PATTERN

Typical power-consumption test patterns consist of sixteen 30-bit transmit words in 1-channel mode and eight 30-bit transmit words in 2-channel mode. The pattern repeats itself throughout the entire measurement. It is assumed that every possible transmit code on RGB inputs has the same probability to occur during typical device operation.

**Table 7. Typical IC Power-Consumption Test Pattern, 1-Channel Mode**

WORD	TEST PATTERN: R[7:4], R[3:0], G[7:4], G[3:0], B[7:4], B[3:0], 0, VS, HS, DE
1	0x0000007
2	0xFFFF007
3	0x01FFF47
4	0xF0E07F7
5	0x7C3E1E7
6	0xE707C37
7	0xE1CE6C7
8	0xF1B9237
9	0x91BB347
10	0xD4CCC67
11	0xAD53377
12	0xACB2207
13	0xAAB2697
14	0x5556957
15	0xAAAAAB3
16	0xAAAAA5

**Table 8. Typical IC Power-Consumption Test Pattern, 2-Channel Mode**

WORD	TEST PATTERN: R[7:4], R[3:0], G[7:4], G[3:0], B[7:4], B[3:0], 0, VS, HS, DE
1	0x0000001
2	0x03F03F1
3	0xBFFBFF1
4	0x1D71D71
5	0x4C74C71
6	0xC45C451
7	0xA3aA3A5
8	0x5555553

## MAXIMUM POWER CONSUMPTION TEST PATTERN

The maximum (or worst-case) power consumption of the SN65LVDS304 is tested using the two different test patterns shown in [Table 9](#) and [Table 10](#). Test patterns consist of sixteen 30-bit transmit words in 1-channel mode and eight 30-bit transmit words in 2-channel mode. The pattern repeats itself throughout the entire measurement. It is assumed that every possible transmit code on RGB inputs has the same probability to occur during typical device operation.

**Table 9. Worst-Case Power-Consumption  
Test Pattern 1**

WORD	TEST PATTERN: R[7:4], R[3:0], G[7:4], G[3:0], B[7:4], B[3:0], 0, VS, HS, DE
1	0xAAAAA5
2	0x555555

**Table 10. Worst-Case Power-Consumption  
Test Pattern 2**

WORD	TEST PATTERN: R[7:4], R[3:0], G[7:4], G[3:0], B[7:4], B[3:0], 0, VS, HS, DE
1	0x000000
2	0xFFFFF7

## OUTPUT SKEW PULSE POSITION and JITTER PERFORMANCE

The following test patterns are used to measure the output skew pulse position and the jitter performance of the SN65LVDS304. The jitter test pattern stresses the interconnect, particularly to test for ISI, using very long run-lengths of consecutive bits, and incorporating very high and low data rates, maximizing switching noise. Each pattern is self-repeating for the duration of the test.

**Table 11. Transmit Jitter Test Pattern, 1-Channel Mode**

WORD	TEST PATTERN: R[7:4], R[3:0], G[7:4], G[3:0], B[7:4], B[3:0], 0, VS, HS, DE
1	0x0000001
2	0x0000031
3	0x00000F1
4	0x00003F1
5	0x0000FF1
6	0x0003FF1
7	0x000FFF1
8	0x0F0F0F1
9	0x0C30C31
10	0x0842111
11	0x1C71C71
12	0x18C6311
13	0x1111111
14	0x3333331
15	0x2452413
16	0x22A2A25
17	0x5555553
18	0xDB6DB65
19	0xCCCCC1
20	0xEEEEE1
21	0xE739CE1
22	0xE38E381
23	0xF7BDEE1
24	0xF3CF3C1
25	0xF0F0F01
26	0xFFFF001
27	0xFFFC001
28	0xFFFF001
29	0xFFFFC01
30	0xFFFFF01
31	0xFFFFFC1
32	0xFFFFF1

**Table 12. Transmit Jitter Test Pattern, 2-Channel Mode**

WORD	TEST PATTERN: R[7:4], R[3:0], G[7:4], G[3:0], B[7:4], B[3:0], 0,VS,HS,DE
1	0x0000001
2	0x000FFF3
3	0x8008001
4	0x0030037
5	0xE00E001
6	0x00FF001
7	0x007E001
8	0x003C001
9	0x0018001
10	0x1C7E381
11	0x3333331
12	0x555AAA5
13	0x6DBDB61
14	0x7777771
15	0x555AAA3
16	0xAAAAAA5
17	0x5555553
18	0xAAA5555
19	0x8888881
20	0x9242491
21	0xAAA5571
22	0xCCCCCC1
23	0xE3E1C71
24	0xFFE7FF1
25	0xFFC3FF1
26	0xFF81FF1
27	0xFE00FF1
28	0x1FF1FF1
29	0xFFCFFC3
30	0x7FF7FF1
31	0xFFF0007
32	0xFFFFF1

**TYPICAL CHARACTERISTIC CURVES**

Some of the plots in this section show more than one curve representing various device pin relationships. Taken together, they represent a working range for the tested parameter.

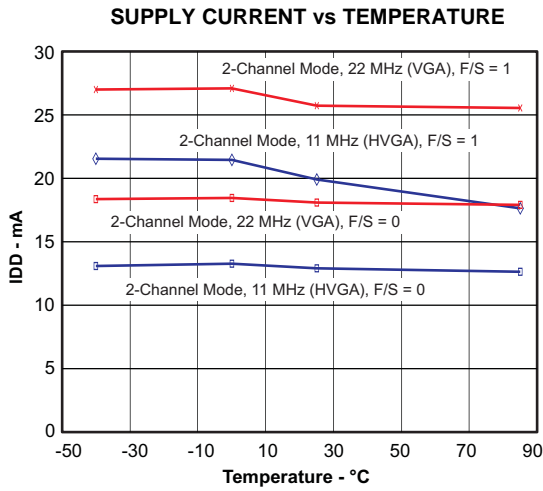

Figure 18.

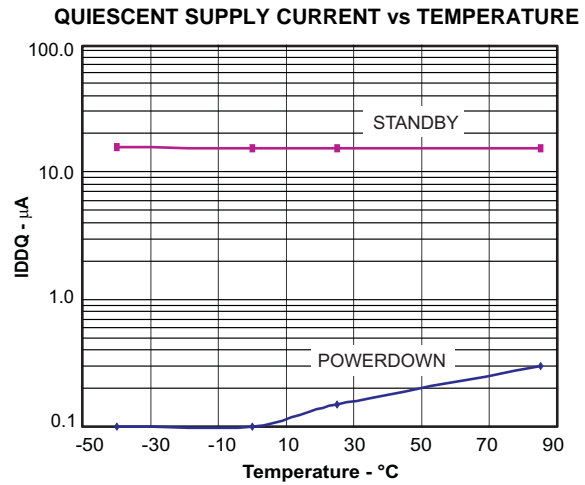

Figure 19.

**SUPPLY CURRENT vs FREQUENCY, 1-CHANNEL MODE**

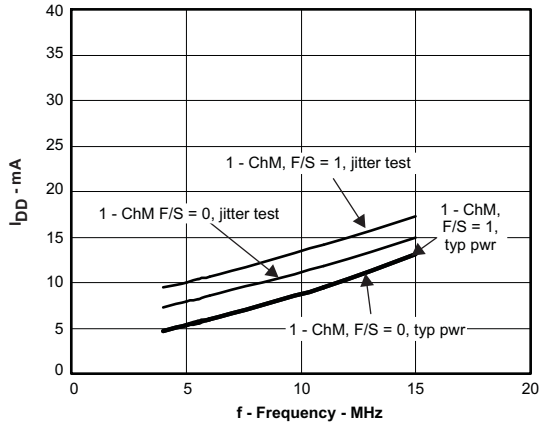

Figure 20.

**SUPPLY CURRENT vs FREQUENCY, 2-CHANNEL MODE**

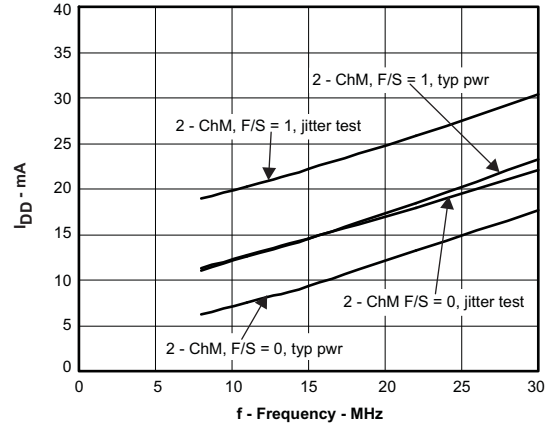

Figure 21.

**RECEIVER STROBE POSITION vs TEMPERATURE**

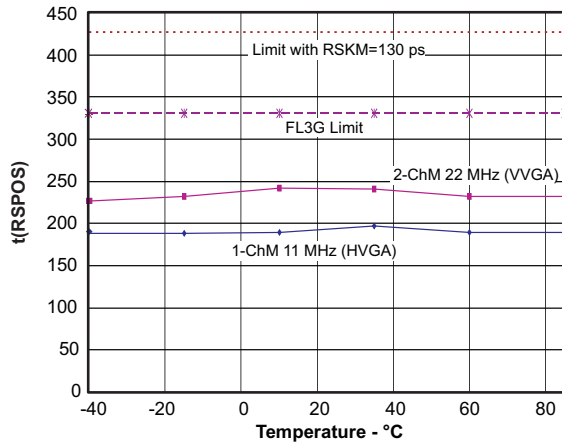

Figure 22.

**PLL BANDWIDTH**

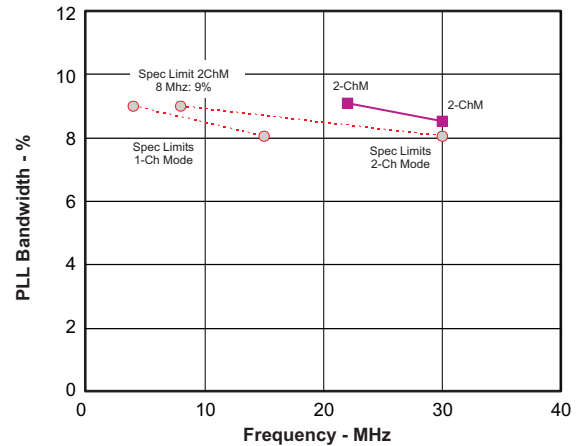

Figure 23.

TYPICAL CHARACTERISTIC CURVES (continued)

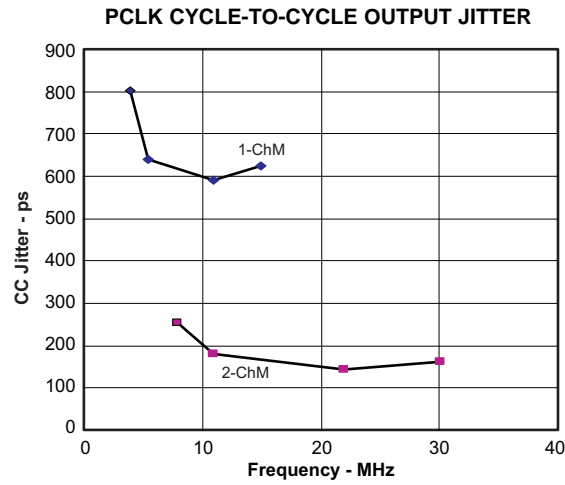

Figure 24.

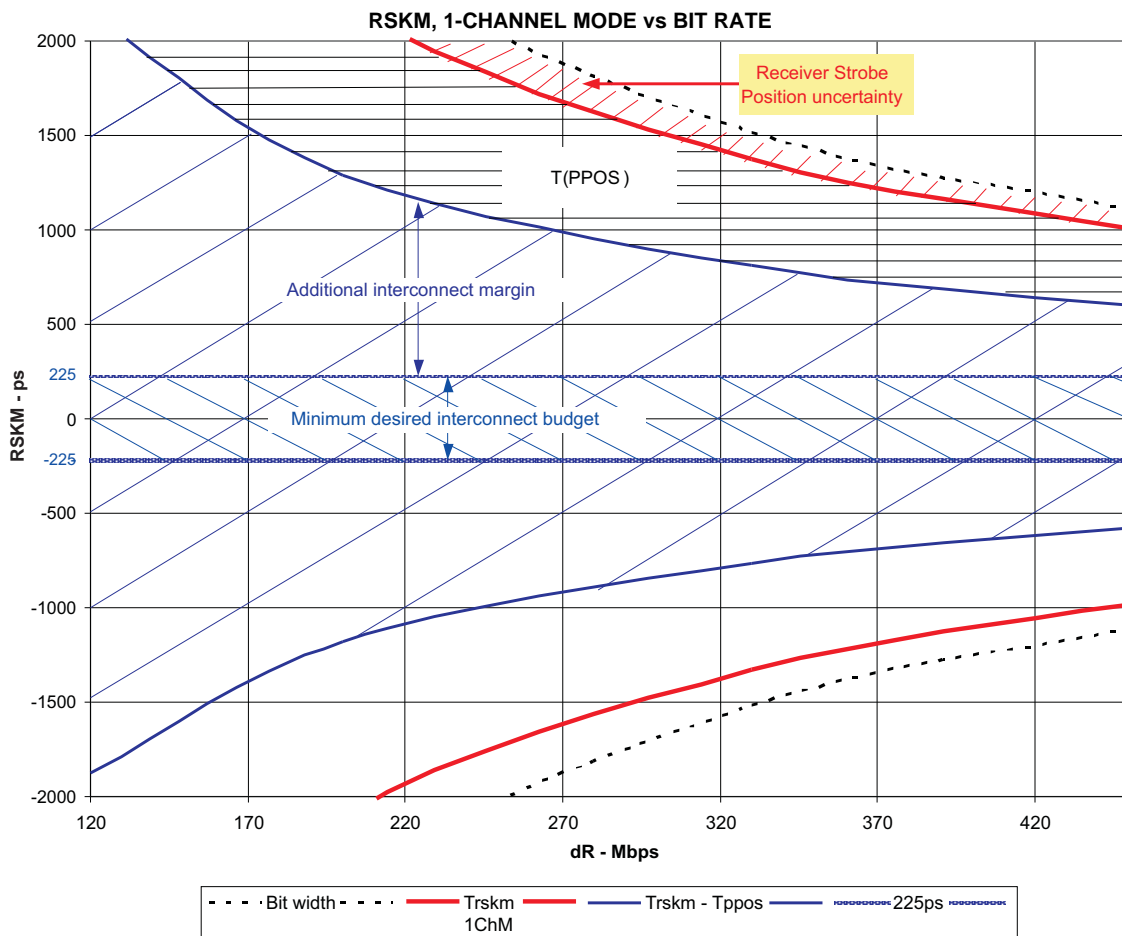

Figure 25.

TYPICAL CHARACTERISTIC CURVES (continued)

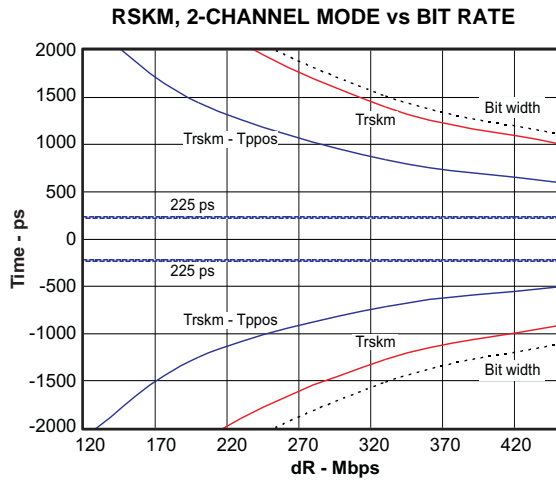

Figure 26.

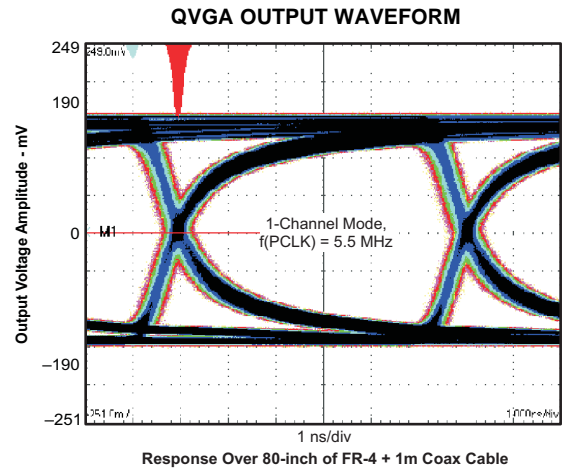

Figure 27.

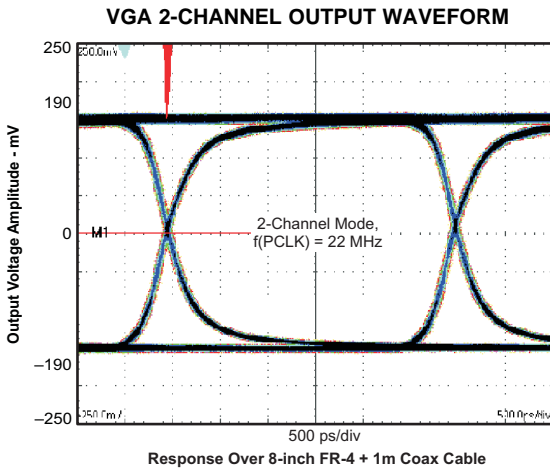

Figure 28.

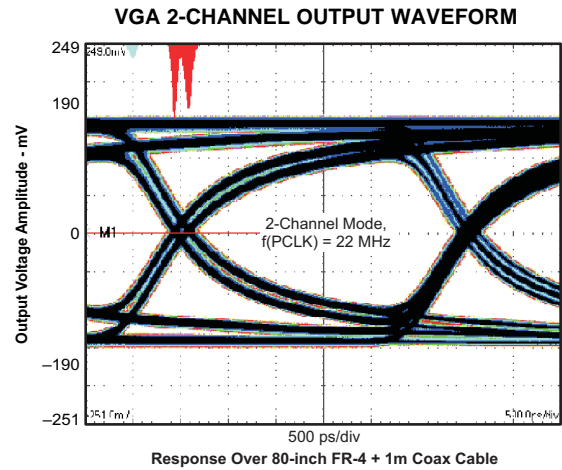

Figure 29.

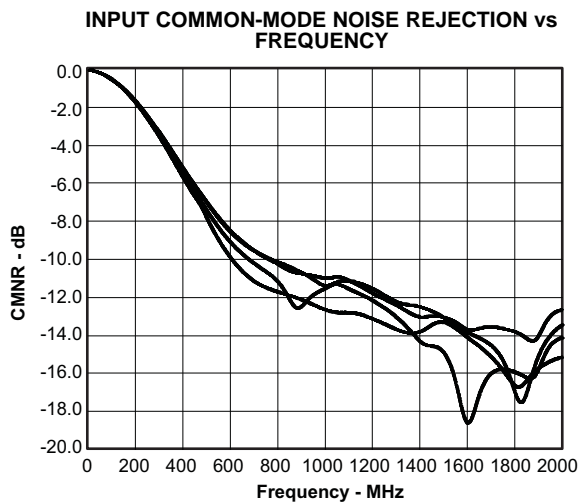

Figure 30.

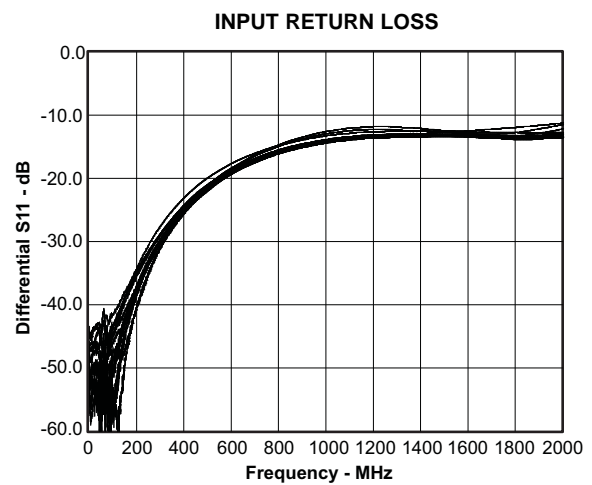

Figure 31.

TYPICAL CHARACTERISTIC CURVES (continued)

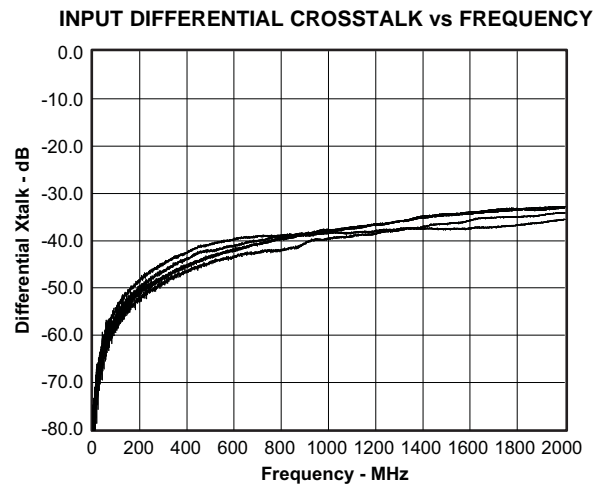

Figure 32.

APPLICATION INFORMATION

PREVENTING INCREASED LEAKAGE CURRENTS IN CONTROL INPUTS

A floating (left open) CMOS input allows leakage currents to flow from  $V_{DD}$  to GND. Do not leave any CMOS input unconnected or floating. Every input must be connected to a valid logic level,  $V_{IH}$  or  $V_{OL}$ , while power is supplied to  $V_{DD}$ . This also minimizes the power consumption of standby and power-down modes.

POWER-SUPPLY DESIGN RECOMMENDATION

For a multilayer PCB, it is recommended to keep one common GND layer underneath the device and connect all ground terminals directly to this plane.

SN65LVDS304 DECOUPLING RECOMMENDATION

The SN65LVDS304 was designed to operate reliably in a constricted environment with other digital switching ICs. In cell phone designs, the SN65LVDS304 often shares a power supply with various other ICs. The SN65LVDS304 can operate with power supply noise as specified in the *Recommended Operating Conditions*. To minimize the power-supply noise floor, provide good decoupling near the SN65LVDS304 power pins. The use of four ceramic capacitors (two 0.01- $\mu$ F and two 0.1- $\mu$ F) provides good performance. At the very least, it is recommended to install one 0.1- $\mu$ F and one 0.01- $\mu$ F capacitor near the SN65LVDS304. To avoid large current loops and trace inductance, the trace length between the decoupling capacitors and IC power input pins must be minimized. Placing the capacitor underneath the SN65LVDS304 on the bottom of the PCB is often a good choice.

VGA APPLICATION

Figure 33 shows a possible implementation of a standard 640  $\times$  480 VGA display. The SN65LVDS303 interfaces to the SN65LVDS304, which is the corresponding receiver device to deserialize the data and drive the display driver. The pixel clock rate of 22 MHz assumes ~10% blanking overhead and 60-Hz display refresh rate. The application assumes 24-bit color resolution. Also shown is how the application processor provides a power-down (reset) signal for both serializer and the display driver. The signal count over the flexible printed circuit board (FPC) could be further decreased by using the standby option on the SN65LVDS304 and pulling RXEN high with a 30-k $\Omega$  resistor to  $V_{DD}$ .

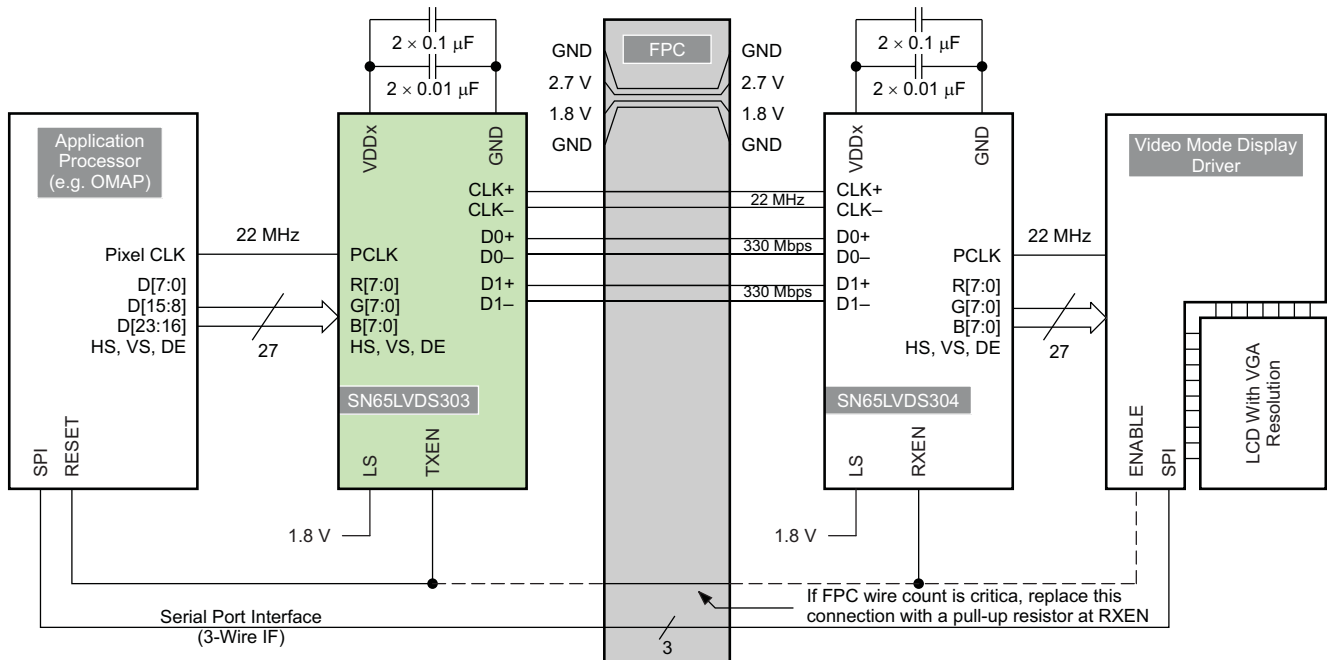

B0178-01

Figure 33. Typical VGA Display Application

## APPLICATION INFORMATION (continued)

### DUAL LCD-DISPLAY APPLICATION

The example in [Figure 34](#) shows a possible application setup driving two video-mode displays from one application processor. The data rate of 330 Mbps at a pixel clock rate of 5.5 MHz corresponds to a 320 × 240 QVGA resolution at 60-Hz refresh rate and 10% blanking overhead.

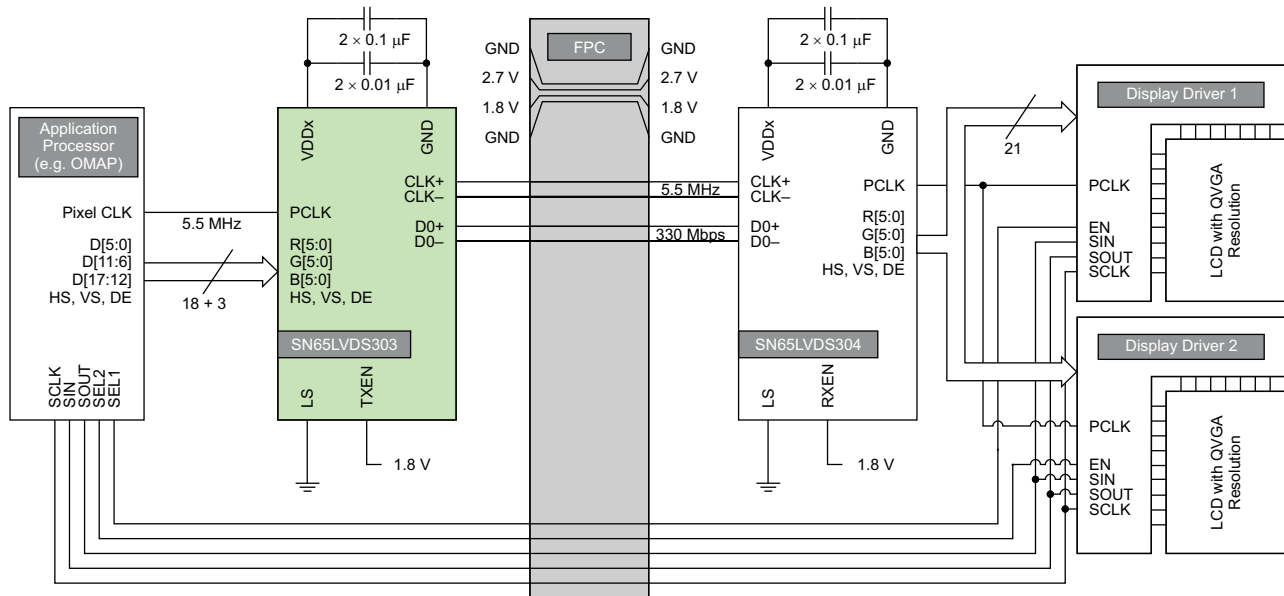

B0179-01

Figure 34. Example Dual-QVGA Display Application

### TYPICAL APPLICATION FREQUENCIES

The SN65LVDS304 supports pixel clock frequencies from 4 MHz to 30 MHz over 1 or 2 data pairs. [Table 13](#) provides a few typical display resolution examples and shows the number of data pairs necessary to connect the SN65LVDS304 with the display. The blanking overhead is assumed to be 20%. Often, blanking overhead is smaller, resulting in a lower data rate. Furthermore, the examples in the table assumes a display frame refresh rate of 60 Hz. The actual refresh rate may differ, depending on the application-processor clock implementation.

Table 13. Typical Application Data Rates and Serial Lane Usage

Display Screen Resolution	Visible Pixel Count	Blanking Overhead	Display Refresh Rate	Pixel Clock Frequency [MHz]	Serial Data Rate Per Pair	
					1-ChM	2-ChM
176 × 220 (QCIF+)	38,720	20%	90 Hz	4.2 MHz	125 Mbps	
240 × 320 (QVGA)	76,800	20%	60 Hz	5.5 MHz	166 Mbps	
640 × 200	128,000	20%	60 Hz	9.2 MHz	276 Mbps	138 Mbps
352 × 416 (CIF+)	146,432	20%	60 Hz	10.5 MHz	316 Mbps	158 Mbps
352 × 440	154,880	20%	60 Hz	11.2 MHz	335 Mbps	167 Mbps
320 × 480 (HVGA)	153,600	20%	60 Hz	11.1 MHz	332 Mbps	166 Mbps
800 × 250	200,000	20%	60 Hz	14.4 MHz	432 Mbps	216 Mbps
640x320	204,800	20%	60 Hz	14.7 MHz	442 Mbps	221 Mbps
640 × 480 (VGA)	307,200	20%	60 Hz	22.1 MHz		332 Mbps
1024 × 320	327,680	20%	60 Hz	23.6 MHz		354 Mbps
854 × 480 (WVGA)	409,920	20%	60 Hz	29.5 MHz		443 Mbps

## CALCULATION EXAMPLE: HVGA DISPLAY

The following calculation shows an example for a half-VGA display with the following parameters:

Display resolution:	480 × 320
Frame refresh rate:	58.4 Hz
Vertical visible pixels:	320 lines
Vertical front porch:	10 lines
Vertical sync:	5 lines
Vertical back porch:	3 lines
Horizontal visible pixels:	480 columns
Horizontal front porch:	20 columns
Horizontal sync:	5 columns
Horizontal back porch:	3 columns

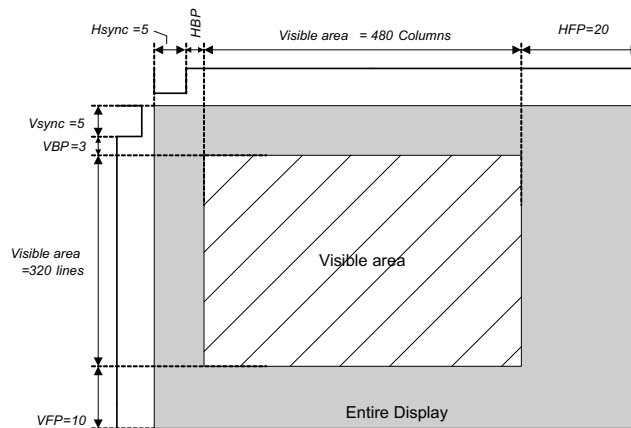

Figure 35. HVGA Display

*Calculation of the total number of pixels and blanking overhead:*

Visible area pixel count:	$480 \times 320 = 153,600$ pixels
Total frame pixel count:	$(320 + 10 + 5 + 3) \times (480 + 20 + 5 + 3) = 171,704$ pixels
Blanking overhead:	$(171,704 - 153,600) \div 153,600 \approx 11.8\%$

*The application requires the following serial-link parameters:*

Pixel clock frequency:	$171,704 \times 58.4 \text{ Hz} = 10 \text{ MHz}$
Serial data rate:	1-channel mode: $10 \text{ MHz} \times 30 \text{ bits/channel} = 300 \text{ Mbps}$
	2-channel mode: $10 \text{ MHz} \times 15 \text{ bits/channel} = 150 \text{ Mbps}$

## HOW TO DETERMINE INTERCONNECT SKEW AND JITTER BUDGET

Designing a reliable data link requires examining the interconnect skew and jitter budget. The sum of all transmitter, PCB, connector, FPC, and receiver uncertainties must be smaller than the available serial bit time. The highest pixel clock frequency defines the available serial bit time. The transmitter timing uncertainty is defined by  $t_{PPOS}$  in the transmitter data sheet. For a bit-error-rate target of  $\leq 10^{-12}$ , the measurement duration for  $t_{PPOS}$  is  $\geq 10^{12}$ . The SN65LVDS304 receiver can tolerate a maximum timing uncertainty defined by  $t_{RSKM}$ . The interconnect budget is calculated by:

$$t_{interconnect} = t_{RSKM} - t_{PPOS}$$

### Example:

$f_{PCLK}(\max) = 23 \text{ MHz}$  (VGA display resolution, 60 Hz)

Transmission mode: 2-ChM;  $t_{PPOS}(\text{SN65LVDS303}) = 330 \text{ ps}$

Target bit error rate:  $10^{-12}$

$t_{RSKM}(\text{SN65LVDS304}) = 1/(2 \times 15 \times f_{PCLK}) - 480 \text{ ps} = 969 \text{ ps}$

The interconnect budget for cable skew and ISI must be smaller than:

$$t_{interconnect} = t_{RSKM} - t_{PPOS} = 639 \text{ ps}$$

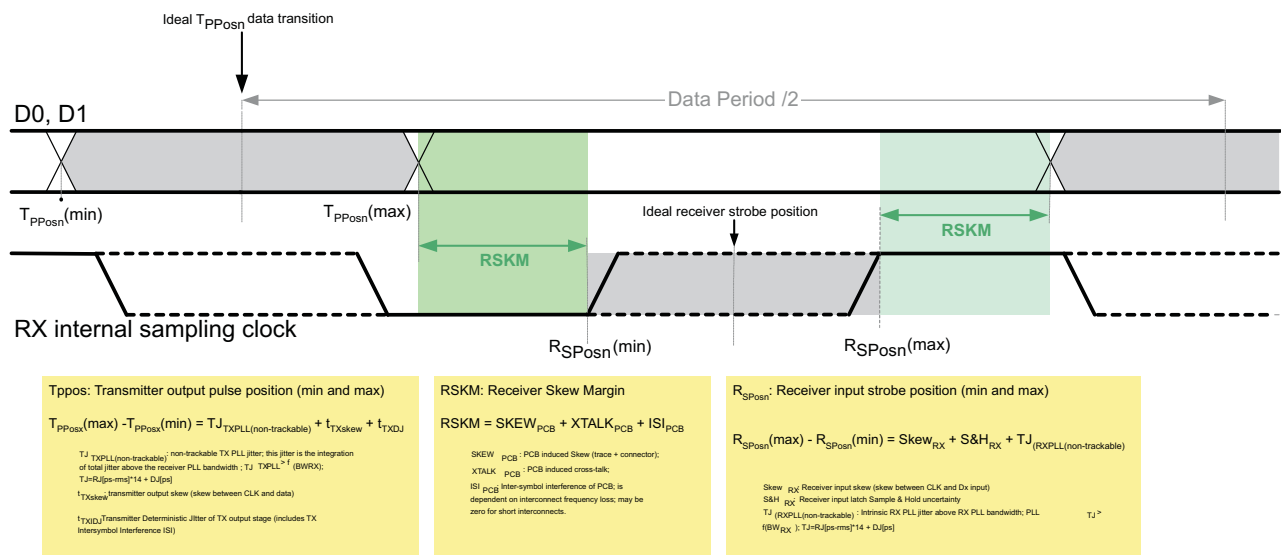

T0165-01

Figure 36. Jitter Budget

## F/S-PIN SETTING AND CONNECTING THE SN65LVDS304 TO AN LCD DRIVER

### NOTE:

**Receiver PLL tracking:** To maximize the design margin for the interconnect, good RX PLL tracking of the TX PLL is important. FlatLink3G requires the RX PLL to have a bandwidth higher than the bandwidth of the TX PLL. The SN65LVDS304 PLL design is optimized to track the SN65LVDS303 PLL particularly well, thus providing a very large receiver skew margin. A FlatLink3G-compliant link must provide at least  $\pm 225$  ppm of receiver skew margin for the interconnect.

It is important to understand the tradeoff between power consumption, EMI, and maximum speed when selecting the F/S signal. It is beneficial to choose the slowest rise time possible to minimize EMI and power consumption. Unfortunately a slower rise time also reduces the timing margin left for the LCD driver. Hence, it is necessary to calculate the timing margin to select the correct F/S pin setting.

The output rise time depends on the output driver strength and the output load. An LCD driver typical capacitive load is assumed with  $\sim 10$  pF. The higher the capacitive load, the slower is the rise time. Rise time of the SN65LVDS304 is measured as the time duration it takes the output voltage to rise from 20% of  $V_{DD}$  to 80% of  $V_{DD}$ , and fall time is defined as the time for the output voltage to transition from 80% of  $V_{DD}$  down to 20% of  $V_{DD}$ .

Within one mode of operation and one F/S pin setting, the rise time of the output stage is fixed and does not adjust to the pixel frequency. Due to the short bit time at very fast pixel clock speeds and the real capacitive load of the display driver, the output amplitude might not reach  $V_{DD}$  and GND saturation fully. To ensure sufficient signal swing and verify the design margin, it becomes necessary to determine that the output amplitude under any circumstance reaches the display driver's input stage logic threshold (usually 30% and 70% of  $V_{DD}$ ).

Figure 37 shows a worst-case rise time simulation assuming an LCD driver load of 16 pF at VGA display resolution. PCLK is the fastest-switching output. With F/S set to GND (Figure 37-a), the PCLK output voltage amplitude is significantly reduced. The voltage amplitude of the output data RGB[7:0], VS, HS, and DE shows less amplitude attenuation because these outputs carry random data patterns and toggle at half of the PCLK frequency or less. It is necessary to determine the timing margin between the SN65LVDS304 output and LCD driver input.

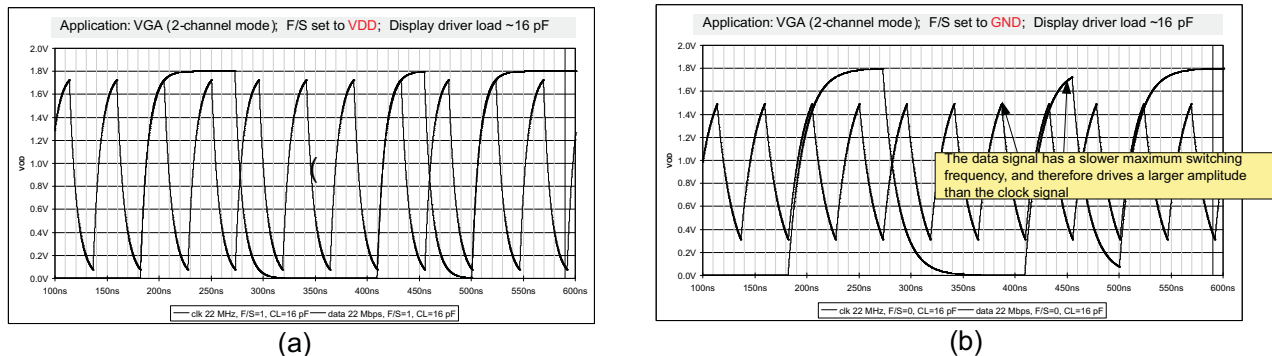

**Figure 37. Output Amplitude as a Function of Output Toggling Frequency, Capacitive Load, and F/S Setting**

## HOW TO DETERMINE THE LCD DRIVER TIMING MARGIN

To determine the timing margin, it is necessary to specify the frequency of operation, identify the setup and hold times of the LCD driver, and specify the output load of the SN65LVDS304 as a combination of the LCD driver input parasitics plus any capacitance caused by the connecting PCB trace. Furthermore, the setting of pin F/S and the SN65LVDS304 output skew impact the margin. The total remaining design margin calculates as follows:

$$t_{DM} = \frac{1}{2 \times f_{PCLK}} - t_{DUTP(max\_error)} - \frac{t_{rise(max)} \times C_{LOAD}}{10 \text{ pF}} - |t_{OSK}| \quad (3)$$

where:

- $t_{DM}$  – Design margin
- $f_{PCLK}$  – Pixel clock frequency
- $t_{DUTP(max\_error)}$  – maximum duty cycle error
- $t_{rise(max)}$  – maximum rise or fall time; see  $t_{R/F}$  under switching characteristics
- $C_L$  – parasitic capacitance (sum of LCD driver input parasitics + connecting PCB trace)
- $t_{skew}$  – clock to data output skew SN65LVDS304

### Example:

At a pixel clock frequency of 5.5MHz (QVGA), and an assumed LCD driver load of 15 pF, the remaining timing margin is:

$$t_{DUTP(max\_error)} = \frac{|t_{DUTP(max)} - 50|}{100\%} \times t_{PCLK} = \frac{5\%}{100\%} \times \frac{1}{5.5\text{MHz}} = 9.1\text{ns}$$

$$t_{DM} = \frac{1}{2 \times 5.5\text{MHz}} - 9\text{ns} - \frac{16\text{ns}_{(F/S=GND)} \times 15\text{pF}}{10\text{pF}} - 500\text{ps} = 57.3\text{ns}$$

As long as the setup and hold times of the LCD driver are each less than 57 ns, the timing budget is met sufficiently.

**PACKAGING INFORMATION**

Orderable Device	Status (1)	Package Type	Package Drawing	Pins	Package Qty	Eco Plan (2)	Lead/Ball Finish (6)	MSL Peak Temp (3)	Op Temp (°C)	Device Marking (4/5)	Samples
SN65LVDS304ZQER	ACTIVE	BGA MICROSTAR JUNIOR	ZQE	80		TBD	Call TI	Call TI	-40 to 85	LVDS304	Samples

(1) The marketing status values are defined as follows:

**ACTIVE:** Product device recommended for new designs.

**LIFEBUY:** TI has announced that the device will be discontinued, and a lifetime-buy period is in effect.

**NRND:** Not recommended for new designs. Device is in production to support existing customers, but TI does not recommend using this part in a new design.

**PREVIEW:** Device has been announced but is not in production. Samples may or may not be available.

**OBsolete:** TI has discontinued the production of the device.

(2) Eco Plan - The planned eco-friendly classification: Pb-Free (RoHS), Pb-Free (RoHS Exempt), or Green (RoHS & no Sb/Br) - please check <http://www.ti.com/productcontent> for the latest availability information and additional product content details.

**TBD:** The Pb-Free/Green conversion plan has not been defined.

**Pb-Free (RoHS):** TI's terms "Lead-Free" or "Pb-Free" mean semiconductor products that are compatible with the current RoHS requirements for all 6 substances, including the requirement that lead not exceed 0.1% by weight in homogeneous materials. Where designed to be soldered at high temperatures, TI Pb-Free products are suitable for use in specified lead-free processes.

**Pb-Free (RoHS Exempt):** This component has a RoHS exemption for either 1) lead-based flip-chip solder bumps used between the die and package, or 2) lead-based die adhesive used between the die and leadframe. The component is otherwise considered Pb-Free (RoHS compatible) as defined above.

**Green (RoHS & no Sb/Br):** TI defines "Green" to mean Pb-Free (RoHS compatible), and free of Bromine (Br) and Antimony (Sb) based flame retardants (Br or Sb do not exceed 0.1% by weight in homogeneous material)

(3) MSL, Peak Temp. - The Moisture Sensitivity Level rating according to the JEDEC industry standard classifications, and peak solder temperature.

(4) There may be additional marking, which relates to the logo, the lot trace code information, or the environmental category on the device.

(5) Multiple Device Markings will be inside parentheses. Only one Device Marking contained in parentheses and separated by a "~" will appear on a device. If a line is indented then it is a continuation of the previous line and the two combined represent the entire Device Marking for that device.

(6) Lead/Ball Finish - Orderable Devices may have multiple material finish options. Finish options are separated by a vertical ruled line. Lead/Ball Finish values may wrap to two lines if the finish value exceeds the maximum column width.

**Important Information and Disclaimer:** The information provided on this page represents TI's knowledge and belief as of the date that it is provided. TI bases its knowledge and belief on information provided by third parties, and makes no representation or warranty as to the accuracy of such information. Efforts are underway to better integrate information from third parties. TI has taken and continues to take reasonable steps to provide representative and accurate information but may not have conducted destructive testing or chemical analysis on incoming materials and chemicals. TI and TI suppliers consider certain information to be proprietary, and thus CAS numbers and other limited information may not be available for release.

In no event shall TI's liability arising out of such information exceed the total purchase price of the TI part(s) at issue in this document sold by TI to Customer on an annual basis.

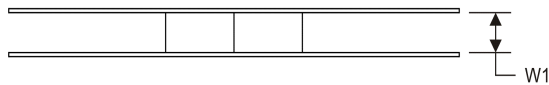
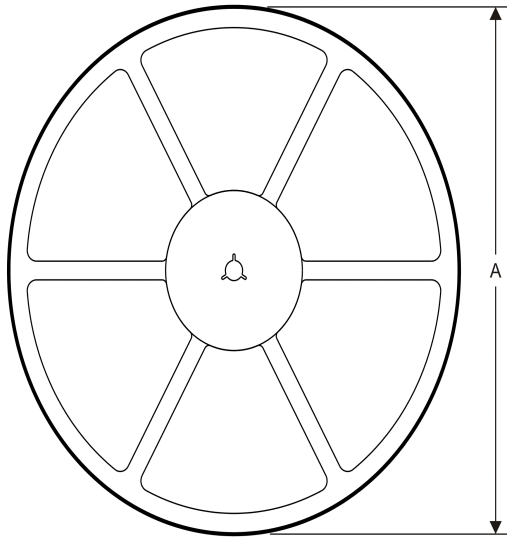
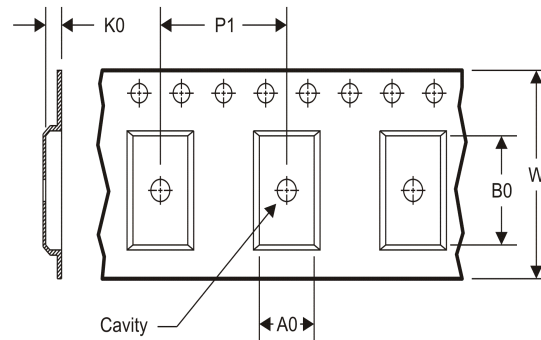
**TAPE AND REEL INFORMATION**
**REEL DIMENSIONS**

**TAPE DIMENSIONS**

A0	Dimension designed to accommodate the component width
B0	Dimension designed to accommodate the component length
K0	Dimension designed to accommodate the component thickness
W	Overall width of the carrier tape
P1	Pitch between successive cavity centers

**TAPE AND REEL INFORMATION**

\*All dimensions are nominal

Device	Package Type	Package Drawing	Pins	SPQ	Reel Diameter (mm)	Reel Width W1 (mm)	A0 (mm)	B0 (mm)	K0 (mm)	P1 (mm)	W (mm)	Pin1 Quadrant
SN65LVDS304ZQER	BGA MICROSTAR JUNIOR	ZQE	80	2500	330.0	12.4	5.3	5.3	1.5	8.0	12.0	Q1

TAPE AND REEL BOX DIMENSIONS



\*All dimensions are nominal

Device	Package Type	Package Drawing	Pins	SPQ	Length (mm)	Width (mm)	Height (mm)
SN65LVDS304ZQER	BGA MICROSTAR JUNIOR	ZQE	80	2500	338.1	338.1	20.6

# MECHANICAL DATA

ZQE (S-PBGA-N80)

PLASTIC BALL GRID ARRAY

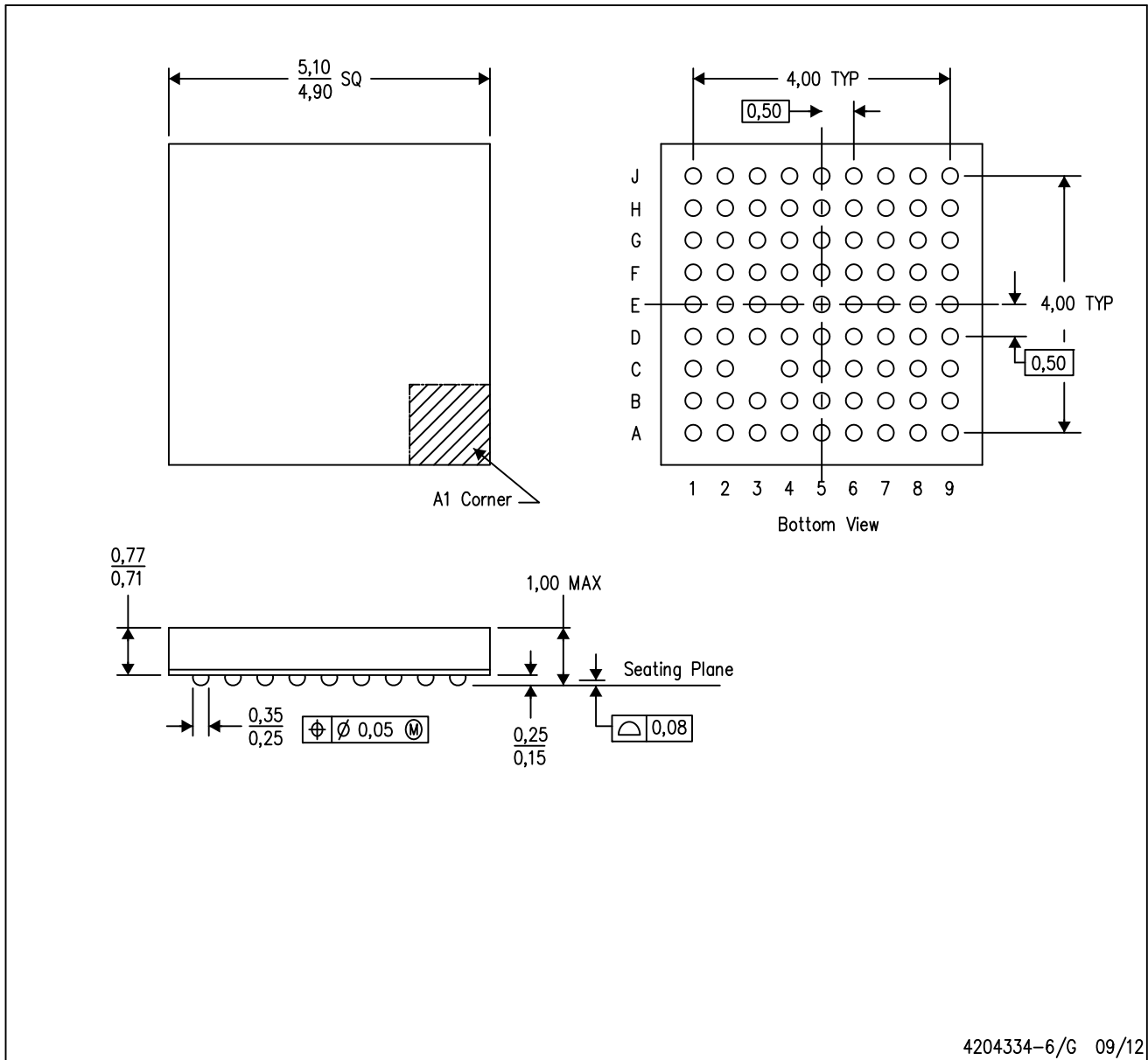

- NOTES:
- A. All linear dimensions are in millimeters. Dimensioning and tolerancing per ASME Y14.5M-1994.
  - B. This drawing is subject to change without notice.
  - C. Falls within JEDEC MO-225
  - D. This is a Pb-free solder ball design.

MicroStar Junior is a trademark of Texas Instruments.

## IMPORTANT NOTICE

Texas Instruments Incorporated and its subsidiaries (TI) reserve the right to make corrections, enhancements, improvements and other changes to its semiconductor products and services per JESD46, latest issue, and to discontinue any product or service per JESD48, latest issue. Buyers should obtain the latest relevant information before placing orders and should verify that such information is current and complete. All semiconductor products (also referred to herein as "components") are sold subject to TI's terms and conditions of sale supplied at the time of order acknowledgment.

TI warrants performance of its components to the specifications applicable at the time of sale, in accordance with the warranty in TI's terms and conditions of sale of semiconductor products. Testing and other quality control techniques are used to the extent TI deems necessary to support this warranty. Except where mandated by applicable law, testing of all parameters of each component is not necessarily performed.

TI assumes no liability for applications assistance or the design of Buyers' products. Buyers are responsible for their products and applications using TI components. To minimize the risks associated with Buyers' products and applications, Buyers should provide adequate design and operating safeguards.

TI does not warrant or represent that any license, either express or implied, is granted under any patent right, copyright, mask work right, or other intellectual property right relating to any combination, machine, or process in which TI components or services are used. Information published by TI regarding third-party products or services does not constitute a license to use such products or services or a warranty or endorsement thereof. Use of such information may require a license from a third party under the patents or other intellectual property of the third party, or a license from TI under the patents or other intellectual property of TI.

Reproduction of significant portions of TI information in TI data books or data sheets is permissible only if reproduction is without alteration and is accompanied by all associated warranties, conditions, limitations, and notices. TI is not responsible or liable for such altered documentation. Information of third parties may be subject to additional restrictions.

Resale of TI components or services with statements different from or beyond the parameters stated by TI for that component or service voids all express and any implied warranties for the associated TI component or service and is an unfair and deceptive business practice. TI is not responsible or liable for any such statements.

Buyer acknowledges and agrees that it is solely responsible for compliance with all legal, regulatory and safety-related requirements concerning its products, and any use of TI components in its applications, notwithstanding any applications-related information or support that may be provided by TI. Buyer represents and agrees that it has all the necessary expertise to create and implement safeguards which anticipate dangerous consequences of failures, monitor failures and their consequences, lessen the likelihood of failures that might cause harm and take appropriate remedial actions. Buyer will fully indemnify TI and its representatives against any damages arising out of the use of any TI components in safety-critical applications.

In some cases, TI components may be promoted specifically to facilitate safety-related applications. With such components, TI's goal is to help enable customers to design and create their own end-product solutions that meet applicable functional safety standards and requirements. Nonetheless, such components are subject to these terms.

No TI components are authorized for use in FDA Class III (or similar life-critical medical equipment) unless authorized officers of the parties have executed a special agreement specifically governing such use.

Only those TI components which TI has specifically designated as military grade or "enhanced plastic" are designed and intended for use in military/aerospace applications or environments. Buyer acknowledges and agrees that any military or aerospace use of TI components which have **not** been so designated is solely at the Buyer's risk, and that Buyer is solely responsible for compliance with all legal and regulatory requirements in connection with such use.

TI has specifically designated certain components as meeting ISO/TS16949 requirements, mainly for automotive use. In any case of use of non-designated products, TI will not be responsible for any failure to meet ISO/TS16949.

### Products

Audio	<a href="http://www.ti.com/audio">www.ti.com/audio</a>
Amplifiers	<a href="http://amplifier.ti.com">amplifier.ti.com</a>
Data Converters	<a href="http://dataconverter.ti.com">dataconverter.ti.com</a>
DLP® Products	<a href="http://www.dlp.com">www.dlp.com</a>
DSP	<a href="http://dsp.ti.com">dsp.ti.com</a>
Clocks and Timers	<a href="http://www.ti.com/clocks">www.ti.com/clocks</a>
Interface	<a href="http://interface.ti.com">interface.ti.com</a>
Logic	<a href="http://logic.ti.com">logic.ti.com</a>
Power Mgmt	<a href="http://power.ti.com">power.ti.com</a>
Microcontrollers	<a href="http://microcontroller.ti.com">microcontroller.ti.com</a>
RFID	<a href="http://www.ti-rfid.com">www.ti-rfid.com</a>
OMAP Applications Processors	<a href="http://www.ti.com/omap">www.ti.com/omap</a>
Wireless Connectivity	<a href="http://www.ti.com/wirelessconnectivity">www.ti.com/wirelessconnectivity</a>

### Applications

Automotive and Transportation	<a href="http://www.ti.com/automotive">www.ti.com/automotive</a>
Communications and Telecom	<a href="http://www.ti.com/communications">www.ti.com/communications</a>
Computers and Peripherals	<a href="http://www.ti.com/computers">www.ti.com/computers</a>
Consumer Electronics	<a href="http://www.ti.com/consumer-apps">www.ti.com/consumer-apps</a>
Energy and Lighting	<a href="http://www.ti.com/energy">www.ti.com/energy</a>
Industrial	<a href="http://www.ti.com/industrial">www.ti.com/industrial</a>
Medical	<a href="http://www.ti.com/medical">www.ti.com/medical</a>
Security	<a href="http://www.ti.com/security">www.ti.com/security</a>
Space, Avionics and Defense	<a href="http://www.ti.com/space-avionics-defense">www.ti.com/space-avionics-defense</a>
Video and Imaging	<a href="http://www.ti.com/video">www.ti.com/video</a>

### TI E2E Community

[e2e.ti.com](http://e2e.ti.com)

## Looking for pricing, stock, or lifecycle information?

Click below to explore more details on WIN SOURCE:

 [View SN65LVDS304ZQER on WIN SOURCE](#)

 [Texas Instruments](#) Information

## Optimize Your Supply Chain with WIN SOURCE Solutions

-  Global Sourcing Solution
-  Obsolete Management
-  Cost Control Management
-  Shortage Management
-  Alternative Solution
-  Excess Inventory Management